



HOSHIZAKI

Service Manual

Steelheart Series
Refrigerated Kitchen Equipment

Models
Side-Mount Undercounter
Side-Mount Worktop
Equipment Stand



hoshizakiamerica.com

Number: 73255
Issued: 9-8-2025

⚠ WARNING

Only qualified service technicians should install and service the appliance. To obtain the name and phone number of your local Hoshizaki Certified Service Representative, visit www.hoshizakiamerica.com. No service should be undertaken until the technician has thoroughly read this Service Manual. Failure to service and maintain the appliance in accordance with this manual will adversely affect safety, performance, component life, and warranty coverage. Proper installation is the responsibility of the installer. Product failure or property damage due to improper installation is not covered under warranty.

Hoshizaki provides this manual primarily to assist qualified service technicians in the service of the appliance.

Should the reader have any questions or concerns which have not been satisfactorily addressed, please call, send an e-mail message, or write to the Hoshizaki Technical Support Department for assistance.

Phone: 1-800-233-1940; (770) 487-2331

Fax: 1-800-843-1056; (770) 487-3360

E-mail: tech-support@hoshizaki.com

HOSHIZAKI AMERICA, INC.

618 Highway 74 South

Peachtree City, GA 30269

Attn: Hoshizaki Technical Support Department

NOTE: To expedite assistance, all correspondence/communication **MUST** include the following information:

- Model Number _____
- Serial Number _____
- Complete and detailed explanation of the problem.

IMPORTANT

This manual should be read carefully before the appliance is serviced. Read the warnings and guidelines contained in this manual carefully as they provide essential information for the continued safe use, service, and maintenance of the appliance. Retain this manual for any further reference that may be necessary.

CONTENTS

Important Safety Information	4
I. Specifications.....	9
A. Construction.....	9
B. Sidemount and Equipment Stand Refrigeration Circuit Diagram	10
II. Sequence of Operation	11
A. Sequence of Operation Flow Chart.....	11
1. Refrigerator.....	11
2. Freezer	12
III. Service Diagnosis, Refrigeration Circuit Service, and Component Service	13
A. Safety Precautions When Servicing Précautions à prendre lors de l'entretien	13
1. English	13
2. Français.....	18
B. Service Diagnosis	23
C. Thermistor Check.....	30
D. Diagnostic Table	31
E. Controls and Adjustments	33
F. Temperature	35
G. Defrost	37
H. Alarm Safeties.....	38
I. Safety Devices.....	39
IV. Refrigeration Circuit and Component Service Information.....	40
A. Refrigeration Circuit Service Information	42
B. Component Service Information.....	46
V. Maintenance	48
VI. Preparing the Appliance for Periods of Non-Use	49
VII. Disposal and Decommissioning	50
VIII. Technical Information.....	51
A. Electrical and Refrigerant Data	51
1. Sidemount Refrigerator and Freezer.....	51
2. Equipment Stand Refrigerator and Freezer.....	51
B. Wiring Diagram.....	52
1. Sidemount Refrigerator and Freezer.....	52
a) _LR46B(-D2)(-L), _LR60B(-D2)(-D4), _LR67B(-D2)(-D4)	52
b) _LR93B(-D2)(-D4)(-D6).....	53
c) _LF46B, _LF60B, _LF67B	54
2. Equipment Stand Refrigerator and Freezer.....	55
a) CR_B(-L)	55
b) CF_B(-L).....	56

Important Safety Information

Throughout this manual, notices appear to bring your attention to situations which could result in death, serious injury, damage to the appliance, or damage to property.

	<h3>R-290 Class A3 Flammable Refrigerant Used</h3>
⚠ DANGER	Indicates a hazardous situation that, if not avoided, will result in death or serious injury.
⚠ WARNING	Indicates a hazardous situation that, if not avoided, could result in death or serious injury.
NOTICE	Indicates a situation that, if not avoided, could result in damage to the appliance or property.
IMPORTANT	Indicates important information about the use and care of the appliance.
⚠ DANGER	
<p><u>Risk of Fire or Explosion</u> <u>Flammable Refrigerant Used</u></p> <ul style="list-style-type: none"> • Only qualified service technicians should install and service the appliance. Qualified service technicians are those having the appropriate technical training and experience necessary to be aware of hazards to which they are exposed in performing a task and of measures necessary to minimize the danger to themselves or other persons. • No service should be undertaken until the technician has thoroughly read this Service Manual. All safety precautions must be followed. • This appliance to be installed in accordance with the Safety Standard for Refrigeration Systems ANSI/ASHRAE 15. • Follow handling instructions carefully in compliance with national regulations. • Do not use mechanical devices or other means to accelerate the defrosting process or to clean, other than those recommended by the manufacturer. • Do not puncture refrigerant tubing. Risk of fire or explosion due to puncture of refrigerant tubing; follow handling instructions carefully. 	<ul style="list-style-type: none"> • Servicing shall be done by trained service personnel with certified competence in handling flammable refrigerants to minimize the risk of possible ignition due to incorrect parts or improper service. • Component parts shall be replaced with like components. So as to minimize the risk of possible ignition due to incorrect parts. • Dispose of properly in accordance with federal or local regulations. • Do not pierce or burn. • Be aware that refrigerants may not contain an odor. • Do not damage the refrigeration circuit. • See nameplate for R-290 refrigerant charge: <ul style="list-style-type: none"> • If greater than 114 g (4 oz.), do not install in public corridor or lobby. • If greater than 152 g (5.3 oz.), do not install within 6 m (20 ft) of open flame. • The appliance shall be stored in a room without continuously operating ignition sources (for example: open flames, an operating gas appliance, or an operating electric heater).

⚠ DANGER continued

- Do not place any potential ignition sources in or near the appliance.
- Keep clear of obstruction all ventilation openings in the appliance enclosure or in the structure for building-in.
- No potential sources of ignition are to be used in the searching for or detection of refrigerant leaks.
- Do not use electrical appliances inside the appliance unless they are of the type recommended by the manufacturer.
- Do not store explosive substances such as aerosol cans with a flammable propellant in this appliance.
- Check that cabling will not be subject to wear, corrosion, excessive pressure, vibration, sharp edges, or any other adverse environmental effects. The check shall also take into account the effects of aging or continual vibration from sources such as compressors or fans.
- Ensure that the area is in the open or that it is adequately ventilated before breaking into the system or conducting any hot work. A degree of ventilation shall continue during the period that the work is carried out. The ventilation should safely disperse any released refrigerant and preferably expel it externally into the atmosphere.

**Risque D'Incendie ou D'Explosion
Fluide Frigorigène Inflammable Utilisé**

- Seuls des techniciens de service qualifiés doivent installer et entretenir l'appareil. Les techniciens de service qualifiés sont ceux qui possèdent la formation technique et l'expérience nécessaires pour être conscients des dangers auxquels ils sont exposés dans l'accomplissement d'une tâche et des mesures nécessaires pour réduire au minimum le danger pour eux-mêmes ou pour d'autres personnes.
- Aucune opération d'entretien ne doit être entreprise avant que le technicien n'ait lu attentivement ce manuel. Toutes les précautions de sécurité doivent être suivies.
- Cet appareil doit être installé conformément à la norme de sécurité pour les systèmes de réfrigération ANSI/ASHRAE 15.
- Suivez attentivement les instructions de manutention conformément aux règlements nationaux.
- Ne pas utiliser de dispositifs mécaniques ou d'autres moyens pour accélérer le processus de dégivrage ou pour nettoyer, autres que ceux recommandés par le fabricant.
- Ne pas perforer la conduite de fluide frigorigène. Risque d'incendie ou d'explosion en cas de perforation d'une canalisation de fluide frigorigène; suivez attentivement les instructions de manutention.
- L'entretien doit être effectué par du personnel formé et certifié pour la manipulation de réfrigérants inflammables afin de réduire au minimum le risque d'inflammation dû à des pièces incorrectes ou à un entretien inadéquat.
- Les pièces doivent être remplacées par des pièces similaires, de manière à réduire au minimum le risque d'inflammation dû à des pièces incorrectes.

⚠ DANGER Continué

- Mettre au rebut conformément aux règlements fédéraux ou locaux.
 - Ne pas percer ou brûler.
 - Attention, les fluides frigorigènes peuvent ne pas dégager d'odeur.
 - Ne pas endommager les composants du circuit de réfrigération.
 - Voir plaque signalétique pour la charge de réfrigérant R-290:
 - Si elle est supérieure à 114 g (4 oz.), ne pas l'installer dans un couloir public ou un hall d'entrée.
 - Si elle est supérieure à 152 g (5,3 oz.), ne pas l'installer à moins de 6 m (20 pi) d'une flamme nue.
 - L'appareil doit être entreposé dans un local ne contenant pas de sources d'inflammation permanentes (flammes nues, appareil à gaz ou dispositif de chauffage électrique en fonctionnement, par exemple).
 - Ne placer aucune source d'inflammation potentielle à l'intérieur ou à proximité de l'appareil.
 - Ne pas obstruer les ouvertures de ventilation dans l'enceinte de l'appareil ou dans la structure d'encastrement.
 - Aucune source potentielle d'inflammation ne doit être utilisée pour rechercher ou détecter des fuites de réfrigérant.
 - Ne pas utiliser d'appareils électriques à l'intérieur de l'appareil, sauf s'ils sont du type recommandé par le fabricant.
 - Ne pas entreposer dans cet appareil des substances explosives telles que des bombes aérosols contenant un gaz propulseur inflammable.
- Vérifier que le câblage ne sera pas soumis à l'usure, à la corrosion, à une pression excessive, à des vibrations, à des arêtes vives ou à tout autre effet environnemental négatif. Le contrôle doit également prendre en compte les effets du vieillissement ou des vibrations continues provenant de sources telles que les compresseurs ou les ventilateurs.
 - S'assurer que la zone est à l'air libre ou qu'elle est correctement ventilée avant de pénétrer dans le système ou d'effectuer un travail à chaud. Une certaine ventilation doit être maintenue pendant la durée des travaux. La ventilation doit permettre de disperser en toute sécurité tout réfrigérant libéré et, de préférence, de l'expulser dans l'atmosphère.

WARNING

The appliance should be destined only to the use for which it has been expressly conceived. Any other use should be considered improper and therefore dangerous. The manufacturer cannot be held responsible for injury or damage resulting from improper, incorrect, and unreasonable use. Failure to service and maintain the appliance in accordance with this manual will adversely affect safety, performance, component life, and warranty coverage and may result in costly water damage.

To reduce the risk of death, electric shock, serious injury, or fire, follow basic precautions including the following:

- This appliance is not intended for use above 2,000 m (6,561 ft). Installation above 2,000 m (6,561 ft) may adversely affect safety, performance, and component life.
 - Wear appropriate personal protective equipment (PPE) when servicing the appliance.
 - The appliance must be installed in accordance with applicable national, state, and local codes and regulations. Failure to meet these code requirements could result in death, electric shock, serious injury, fire, or damage.
 - The appliance requires an independent power supply of proper capacity. See the nameplate for electrical specifications. Failure to use an independent power supply of proper capacity can result in a tripped breaker, blown fuse, damage to existing wiring, or component failure. This could lead to heat generation or fire.
 - Do not make any alterations to the appliance. Alterations could result in electric shock, injury, fire, or damage to the appliance.
- **THE APPLIANCE MUST BE GROUNDED.** The appliance is equipped with a NEMA 5-15 three-prong grounding plug  to reduce the risk of potential shock hazards. It must be plugged into a properly grounded, independent 3-prong wall outlet. If the outlet is a 2-prong outlet, it is your personal responsibility to have a qualified electrician replace it with a properly grounded, independent 3-prong wall outlet. Do not remove the ground prong from the power cord and do not use an adapter plug. Failure to follow these instructions may result in death, electric shock, or fire.
 - To reduce the risk of electric shock, do not touch the control module with damp hands.
 - To reduce the risk of electric shock, make sure the control module is in the "OFF" position before plugging in or unplugging the appliance.
 - Unplug the appliance before servicing.
 - Do not use an appliance with a damaged power cord. The power cord should not be altered, jerked, bundled, weighed down, pinched, or tangled. Such actions could result in electric shock or fire. To unplug the appliance, be sure to pull the plug, not the cord, and do not jerk the cord.
 - Do not use an extension cord.
 - If the supply cord is damaged, it must be replaced by the manufacturer, its service agent, or similarly qualified persons in order to avoid a hazard. Upon replacement, the GREEN ground wire in the power cord must be connected to the designated grounding screw.
 - Appliance is heavy. Use care when lifting or positioning. Work in pairs when needed to prevent injury or damage.

⚠ WARNING continued

- The appliance is not intended for use by persons (including children) with reduced physical, sensory, or mental capabilities, or lack of experience and knowledge, unless they have been given supervision or instruction concerning use of the appliance by a person responsible for their safety.
- Do not splash, pour, or spray water directly onto or into the appliance. This might cause short circuit, electric shock, corrosion, or failure.
- Children should be supervised to ensure that they do not play with the appliance.
- Do not climb, stand, or hang on the appliance or drawers or allow children or animals to do so. Do not climb into the appliance or allow children or animals to do so. Death or serious injury could occur or the appliance could be damaged.
- Open and close the door with care. Door opened too quickly or forcefully may cause injury or damage to the appliance or surrounding equipment.
- Be careful not to pinch fingers when opening and closing the door. Be careful when opening and closing the door when children are in the area.
- Do not use combustible spray or place volatile or flammable substances in or near the appliance. They might catch fire.
- Keep the area around the appliance clean. Dirt, dust, or insects in the appliance could cause harm to individuals or damage to the appliance.

NOTICE

- Install the appliance in a location that stays above freezing. Normal operating ambient temperature must be within 45°F to 100°F (7°C to 38°C).
- Do not leave the appliance on during extended periods of non-use, extended absences, or in sub-freezing temperatures. To properly prepare the appliance for these occasions, follow the instructions in "VI. Preparing the Appliance for Periods of Non-Use."
- Do not place objects on top of the appliance.
- Protect the floor when moving the appliance to prevent damage to the floor.
- Do not allow the appliance to bear any outside weight.

I. Specifications

A. Construction

1. Sidemount Refrigerator and Freezer

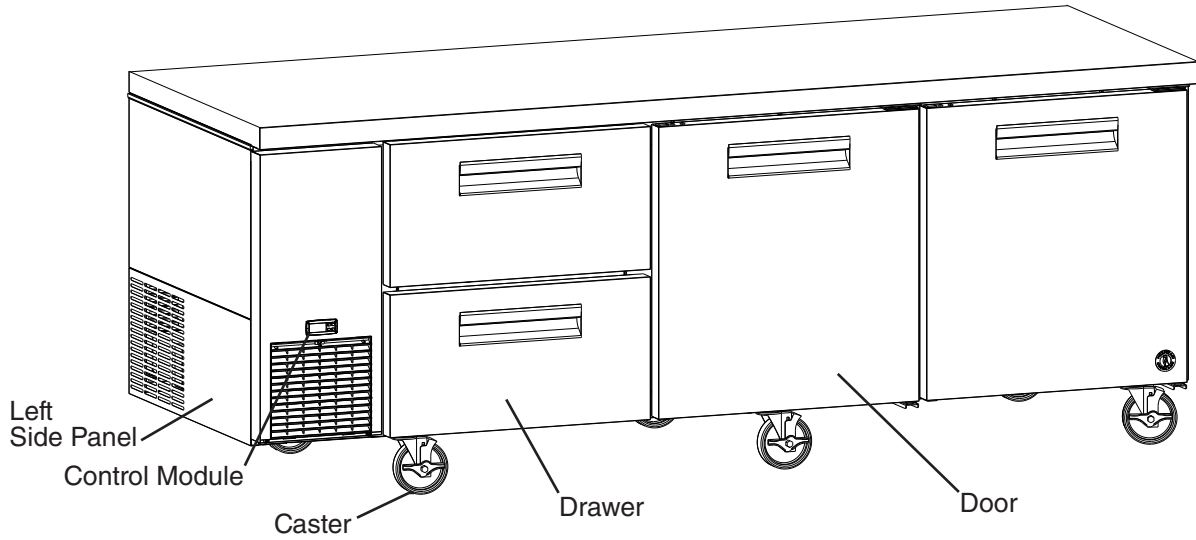

Model Shown: ULR93B-D2

2. Equipment Stand Refrigerator and Freezer

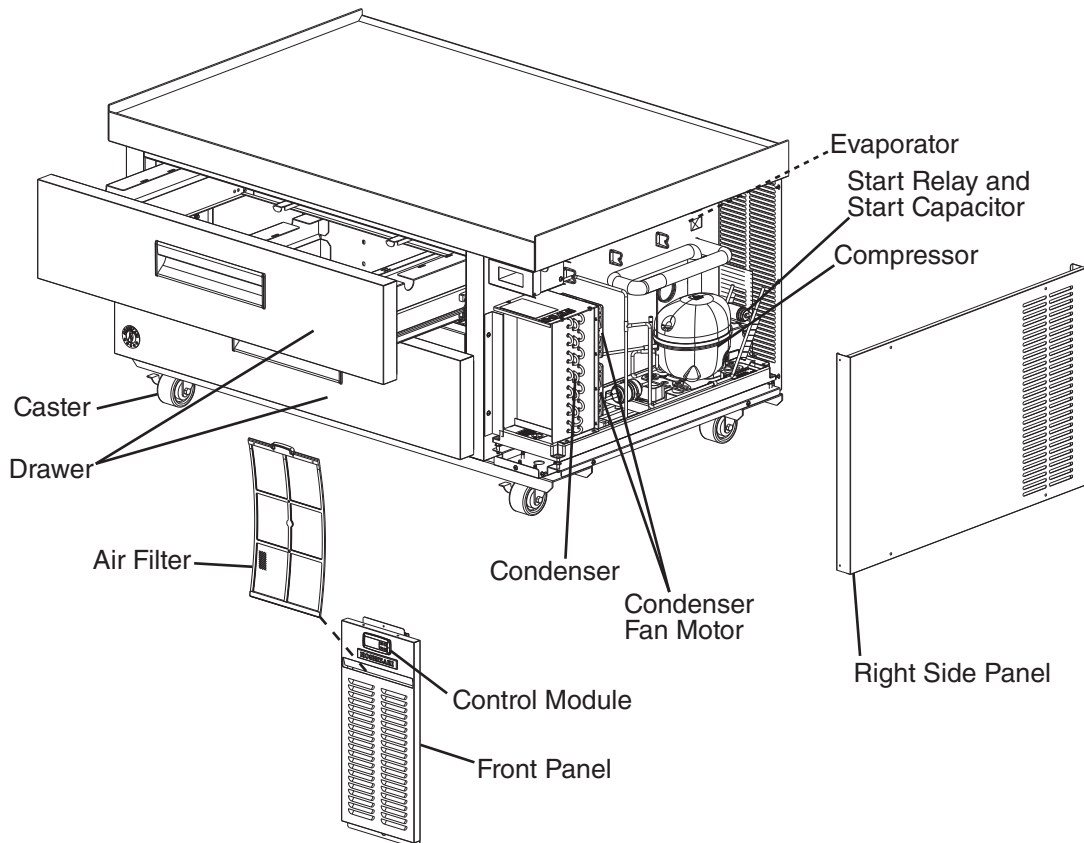

Model Shown: CR49B

B. Sidemount and Equipment Stand Refrigeration Circuit Diagram

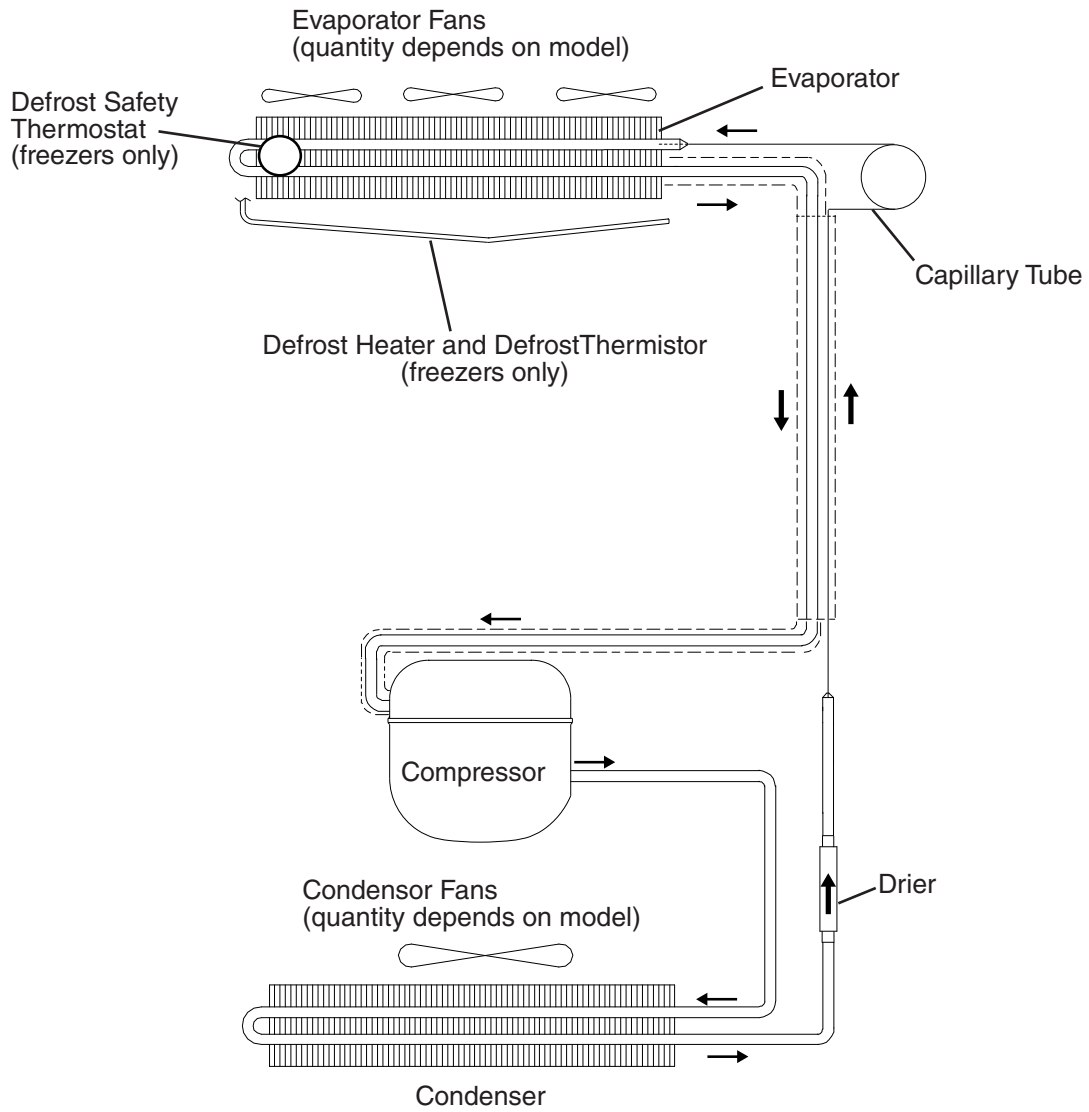

II. Sequence of Operation

A. Sequence of Operation Flow Chart

1. Refrigerator

Refrigerator Sequence Flow Chart

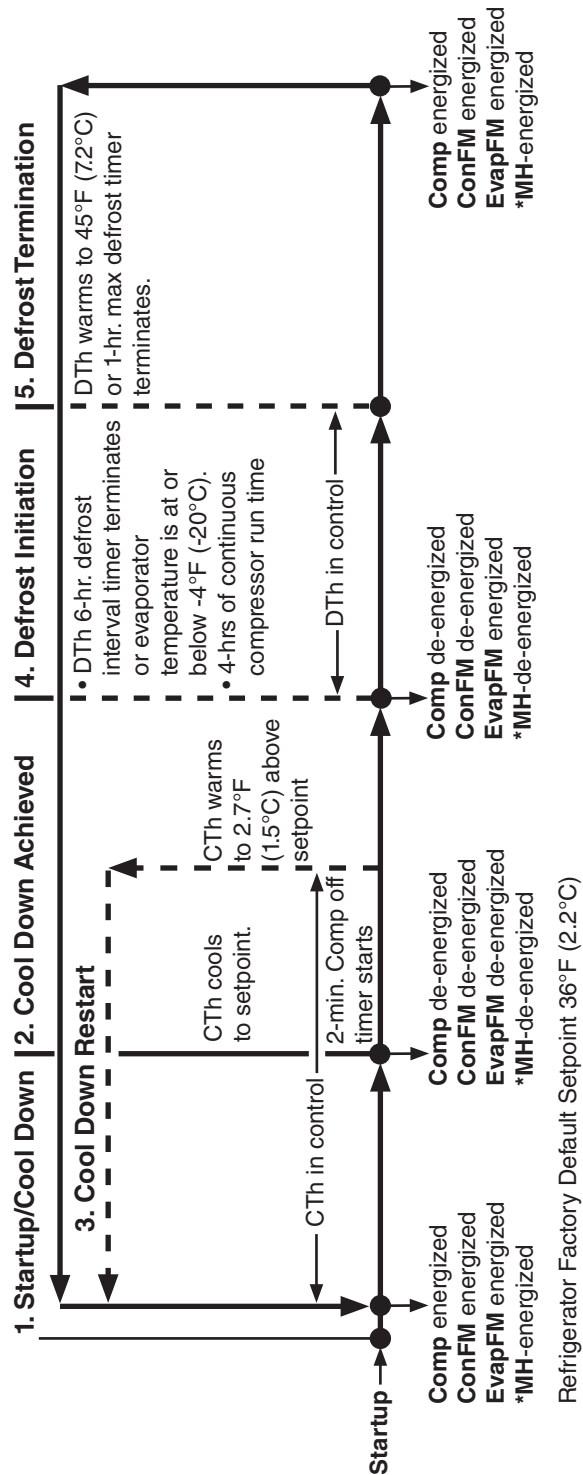

Note:

- a) 2-min. minimum Comp off timer starts when Comp de-energizes.
- b) 1-hr. maximum defrost time.
- c) "dEF" displayed during defrost.
- d) Defrost Terminates:
 - (1) Comp icon turns on, Comp energizes.
 - (2) EvapFM icon turns solid and EvapFM energizes.
 - (3) "PdF" is displayed until cabinet temperature achieves 2.7°F (1.5°C) above temperature setpoint.

Once 2.7°F (1.5°C) above temperature setpoint is achieved, cabinet temperature returns to display. *Mullion Heater used on Equipment Stand models.

Legend:

- Comp-compressor
- ConFM-condenser fan motor
- CTh-cabinet thermistor
- DTh-defrost thermistor
- EvapFM-evaporator fan motor
- *MH-mullion heater

2. Freezer

Freezer Sequence Flow Chart

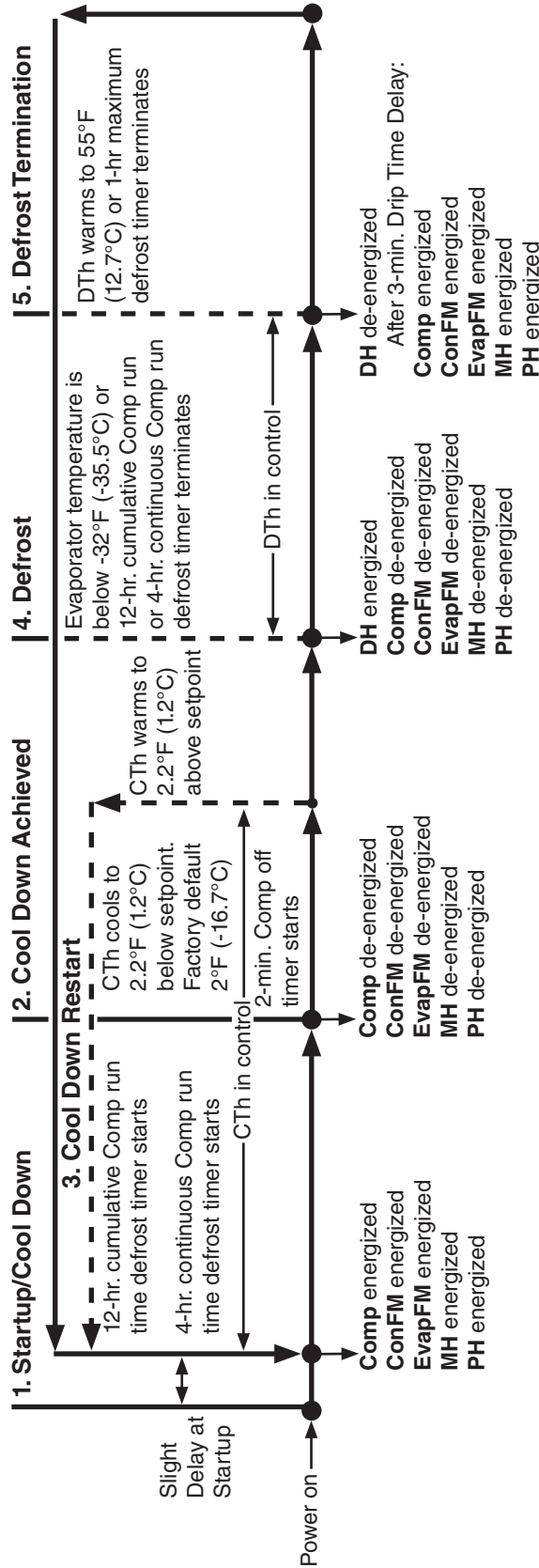

Note:

- a) 2-min. minimum Comp on timer starts when Comp energizes.
 - b) 3-min. minimum Comp off timer starts when Comp de-energizes.
 - c) 1-hr. maximum defrost time.
 - d) "dEF" displayed during defrost.
 - e) 3-min. Comp/ConFM/EvapFM delay timer starts when defrost termination temperature is met.
 - f) "PdF" is displayed until cabinet temperature achieves 2.7°F (1.5°C) above temperature setpoint.
- Once 2.7°F (1.5°C) above temperature setpoint is achieved, cabinet temperature returns to display.

Legend:
Comp -compressor
ConFM -condenser fan motor
CTh -cabinet thermistor
DH -defrost heater
DTh -defrost thermistor
EvapFM -evaporator fan motor
MH -mullion heater
PH -perimeter heater

III. Service Diagnosis, Refrigeration Circuit Service, and Component Service

A. Safety Precautions When Servicing | Précautions à prendre lors de l'entretien

1. English



R-290 Class A3 Flammable Refrigerant Used

⚠ DANGER

Risk of Fire or Explosion. Flammable Refrigerant Used.

- Be sure to follow all Important Safety Information located at the beginning of this manual and in this section.
- The appliance should be diagnosed and repaired only by qualified service personnel to reduce the risk of death, electric shock, serious injury, or fire.
- Servicing shall be done by trained service personnel with certified competence in handling flammable refrigerants to minimize the risk of possible ignition due to incorrect parts or improper service.
- Follow handling instructions carefully in compliance with national regulations.
- Do not use mechanical devices or other means to accelerate the defrosting process or to clean, other than those recommended by the manufacturer.
- Be aware that refrigerants may not contain an odor.
- Do not puncture refrigerant tubing. Risk of fire or explosion due to puncture of refrigerant tubing; follow handling instructions carefully.
- Component parts shall be replaced with like components. So as to minimize the risk of possible ignition due to incorrect parts.
- Do not place any potential ignition sources in or near the appliance.
- Prior to beginning work on systems containing flammable refrigerants, safety checks are necessary to ensure that the risk of ignition is minimized.
- All maintenance staff and others working in the local area shall be instructed on the nature of work being carried out. Work in confined spaces shall be avoided.
- Work shall be undertaken under a controlled procedure so as to minimize the risk of a flammable gas or vapor being present while the work is being performed.
- The area shall be checked with an appropriate refrigerant detector prior to and during work, to ensure the technician is aware of potentially toxic or flammable atmospheres.
- Ensure that the leak detection equipment being used is suitable for use with all applicable refrigerants, i.e., nonsparking, adequately sealed, or intrinsically safe.
NOTE: The use of silicone sealant can inhibit the effectiveness of some types of leak detection equipment.

⚠ DANGER continued

- Under no circumstances shall potential sources of ignition be used in the searching for or detection of refrigerant leaks. A halide torch (or any other detector using a naked flame) shall not be used.
- The following leak detection methods are deemed acceptable for all refrigerant systems:
 - Electronic leak detectors may be used to detect refrigerant leaks but, in the case of flammable refrigerants, the sensitivity might not be adequate, or might need recalibration. (Detection equipment shall be calibrated in a refrigerant-free area.) Ensure that the detector is not a potential source of ignition and is suitable for the refrigerant used. Leak detection equipment shall be set at a percentage of the LFL of the refrigerant and shall be calibrated to the refrigerant employed, and the appropriate percentage of gas (25% maximum) is confirmed.
 - Leak detection fluids are also suitable for use with most refrigerants but the use of detergents containing chlorine shall be avoided as the chlorine can react with the refrigerant and corrode the copper pipe-work.
Note: Examples of leak detection fluids are:
 - bubble method
 - fluorescent method agents
- If any hot work is to be conducted on the refrigerating equipment or any associated parts, appropriate fire extinguishing equipment shall be available on hand. A dry chemical or CO₂ fire extinguisher should be adjacent to the charging area. You must have a Class B chemical fire extinguisher available at all times.
- No person carrying out work in relation to a refrigerating system which involves exposing any pipe work shall use any sources of ignition in such a manner that it may lead to the risk of fire or explosion. All possible ignition sources, including cigarette smoking, should be kept sufficiently far away from the site of installation, repairing, removing, and disposal, during which refrigerant can possibly be released to the surrounding space. Prior to work taking place, the area around the equipment shall be surveyed to make sure that there are no flammable hazards or ignition risks. "No Smoking" signs shall be displayed.
- Ensure that the area is in the open or that it is adequately ventilated before breaking into the system or conducting any hot work. A degree of ventilation shall continue during the period that the work is carried out. The ventilation should safely disperse any released refrigerant and preferably expel it externally into the atmosphere.

⚠ DANGER continued

- When breaking into the refrigerant circuit to make repairs – or for any other purpose – conventional procedures shall be used. However, for flammable refrigerants it is important that best practice be followed, since flammability is a consideration. The following procedure shall be adhered to:
 - safely remove refrigerant following local and national regulations
 - purge the circuit with inert gas
 - evacuate (optional for A2L)
 - purge with inert gas (optional for A2L)
 - open the circuit by cutting or brazing
- If a leak is suspected, all naked flames shall be removed/extinguished.
- If a leakage of refrigerant is found which requires brazing, all of the refrigerant shall be recovered from the system, or isolated (by means of shut off valves) in a part of the system remote from the leak.
- When removing refrigerant from a system, either for servicing or decommissioning, it is recommended good practice that all refrigerants are removed safely.
- When transferring refrigerant into cylinders, ensure that only appropriate refrigerant recovery cylinders are employed. Ensure that the correct number of cylinders for holding the total system charge is available. All cylinders to be used are designated for the recovered refrigerant and labeled for that refrigerant (i.e., special cylinders for the recovery of refrigerant). Cylinders shall be complete with pressure-relief valve and associated shut-off valves in good working order. Empty recovery cylinders are evacuated and, if possible, cooled before recovery occurs.
- The recovery equipment shall be in good working order with a set of instructions concerning the equipment that is at hand and shall be suitable for the recovery of all appropriate refrigerants including, when applicable, flammable refrigerants. In addition, a set of calibrated weighing scales shall be available and in good working order. Hoses shall be complete with leak-free disconnect couplings and in good condition. Before using the recovery machine, check that it is in satisfactory working order, has been properly maintained and that any associated electrical components are sealed to prevent ignition in the event of a refrigerant release. Consult manufacturer if in doubt.
- The recovered refrigerant shall be returned to the refrigerant supplier in the correct recovery cylinder, and the relevant waste transfer note arranged. Do not mix refrigerants in recovery units and especially not in cylinders.
- If compressors or compressor oils are to be removed, ensure that they have been evacuated to an acceptable level to make certain that flammable refrigerant does not remain within the lubricant. The evacuation process shall be carried out prior to returning the compressor to the suppliers. Only electric heating to the compressor body shall be employed to accelerate this process. When oil is drained from a system, it shall be carried out safely.

⚠ DANGER continued

- In addition to conventional charging procedures, the following requirements shall be followed:
 - Ensure that contamination of different refrigerants does not occur when using charging equipment. Hoses or lines shall be as short as possible to minimize the amount of refrigerant contained in them.
 - Cylinders shall be kept in an appropriate position according to the instructions.
 - Ensure that the refrigerating system is earthed (grounded) prior to charging the system with refrigerant.
 - Label the system when charging is complete (if not already).
 - Extreme care shall be taken not to overfill the refrigerating system.
- Prior to recharging the system, it shall be pressure-tested with the appropriate purging gas. The system shall be leak-tested on completion of charging but prior to commissioning. A follow up leak test shall be carried out prior to leaving the site.
- Repair and maintenance to electrical components shall include initial safety checks and component inspection procedures. If a fault exists that could compromise safety, then no electrical supply shall be connected to the circuit until it is satisfactorily dealt with. If the fault cannot be corrected immediately but it is necessary to continue operation, an adequate temporary solution shall be used. This shall be reported to the owner of the equipment, so all parties are advised.
- Confirm that capacitors are discharged: this shall be done in a safe manner to avoid possibility of sparking.
- Confirm that no live electrical components and wiring are exposed while charging, recovering, or purging the system.
- Confirm that there is continuity of earth bonding (grounding).
- During repairs to sealed components, all electrical supplies shall be disconnected from the equipment being worked upon prior to any removal of sealed covers, etc. If it is absolutely necessary to have an electrical supply to equipment during servicing, then a permanently operating form of leak detection shall be located at the most critical point to warn of a potentially hazardous situation.
- Where electrical components are being changed, they shall be fit for the purpose and to the correct specification. At all times, Hoshizaki America's maintenance and service guidelines shall be followed. If in doubt, consult Hoshizaki America's Technical Support department for assistance.
- Confirm the actual refrigerant charge is in accordance with the room size within which the refrigerant containing parts are installed.
- Confirm the ventilation machinery and outlets are operating adequately and are not obstructed.
- Confirm marking to the equipment continues to be visible and legible. Markings and signs that are illegible shall be corrected.

⚠ DANGER continued

- Confirm refrigerating pipe or components are installed in a position where they are unlikely to be exposed to any substance which may corrode refrigerant containing components, unless the components are constructed of materials which are inherently resistant to being corroded or are suitably protected against being so corroded.
- Particular attention shall be paid to the following to ensure that by working on electrical components, the casing is not altered in such a way that the level of protection is affected. This shall include damage to cables, excessive number of connections, terminals not made to original specification, damage to seals, incorrect fitting of glands, etc.
- Ensure that the apparatus (control box/component) is mounted securely.
- Ensure that seals or sealing materials have not degraded to the point that they no longer serve the purpose of preventing the ingress of flammable atmospheres. Replacement parts shall be in accordance with Hoshizaki America's specifications.
- Do not apply any permanent inductive or capacitance loads to the circuit without ensuring that this will not exceed the permissible voltage and current permitted for the equipment in use.
- Intrinsically safe components are the only types that can be worked on while live in the presence of a flammable atmosphere. The test apparatus shall be at the correct rating.
- Replace components only with parts specified by Hoshizaki America. Other parts can result in the ignition of refrigerant in the atmosphere from a leak.
- Check that cabling will not be subject to wear, corrosion, excessive pressure, vibration, sharp edges, or any other adverse environmental effects. The check shall also take into account the effects of aging or continual vibration from sources such as compressors or fans.

2. Français



R-290 Classe A3 Réfrigérant Inflammable Utilisé

⚠ DANGER

Risque De Feu Ou D'Explosion. Fluide Frigorigène Inflammable Utilisé.

- Assurez-vous de suivre toutes les informations importantes de sécurité situées au début de ce manuel et dans cette section.
- L'appareil ne doit être diagnostiqué et réparé que par un personnel qualifié afin de prévenir les risques de mort, d'électrocution, de blessures graves ou d'incendie.
- L'entretien doit être effectué par du personnel formé et certifié pour la manipulation de réfrigérants inflammables afin de réduire au minimum le risque d'inflammation dû à des pièces incorrectes ou à un entretien inadéquat.
- Suivez attentivement les instructions de manutention conformément aux règlements nationaux.
- Ne pas utiliser de dispositifs mécaniques ou d'autres moyens pour accélérer le processus de dégivrage ou pour nettoyer, autres que ceux recommandés par le fabricant.
- Attention, les fluides frigorigènes peuvent ne pas dégager d'odeur.
- Ne pas perforer la tubulure contenant le frigorigène. Risque de feu ou d'explosion si la tubulure contenant le frigorigène est perforée; suivre les instructions de manutention avec soin.
- Les pièces doivent être remplacées par des pièces similaires, de manière à réduire au minimum le risque d'inflammation dû à des pièces incorrectes.
- Ne placez aucune source d'inflammation potentielle dans ou près de l'appareil.
- Avant de commencer à travailler sur des systèmes contenant des réfrigérants inflammables, des contrôles de sécurité sont nécessaires pour s'assurer que le risque d'inflammation est minimisé.
- Tout le personnel d'entretien et les autres personnes travaillant dans la zone locale doivent être informés de la nature des travaux effectués. Les travaux dans des espaces confinés doivent être évités.
- Les travaux doivent être entrepris selon une procédure contrôlée afin de minimiser le risque de présence de gaz ou de vapeur inflammable pendant l'exécution des travaux.
- La zone doit être contrôlée à l'aide d'un détecteur de réfrigérant approprié avant et pendant les travaux, afin de s'assurer que le technicien est conscient de l'existence d'atmosphères potentiellement toxiques ou inflammables.
- Assurez-vous que l'équipement de détection des fuites utilisé est adapté à l'utilisation de tous les réfrigérants applicables, c'est-à-dire qu'il ne produit pas d'étincelles, qu'il est correctement scellé ou qu'il est intrinsèquement sûr. REMARQUE: L'utilisation de mastic silicone peut réduire l'efficacité de certains types d'équipements de détection des fuites.

⚠ DANGER Continué

- En aucun cas, des sources potentielles d'inflammation ne doivent être utilisées pour rechercher ou détecter des fuites de réfrigérant. Une lampe haloïde (ou tout autre détecteur utilisant une flamme nue) ne doit pas être utilisée.
- Les méthodes de détection de fuite suivantes sont considérées comme acceptables pour tous les systèmes de réfrigération:
 - Des détecteurs de fuites électroniques peuvent être utilisés pour détecter les fuites de réfrigérants, mais, dans le cas de réfrigérants inflammables, la sensibilité pourrait ne pas être adéquate ou nécessiter un réétalonnage. (L'équipement de détection doit être étalonné dans une zone sans réfrigérant.) Assurez-vous que le détecteur n'est pas une source potentielle d'inflammation et qu'il est adapté au réfrigérant utilisé. L'équipement de détection des fuites doit être réglé sur un pourcentage de la LII du réfrigérant et doit être étalonné en fonction du réfrigérant utilisé, et le pourcentage approprié de gaz (25% au maximum) est confirmé.
 - Les liquides de détection des fuites conviennent également à la plupart des réfrigérants, mais l'utilisation de détergents contenant du chlore doit être évitée, car le chlore peut réagir avec le réfrigérant et corroder la tuyauterie en cuivre.
Remarque : Voici quelques exemples de liquides de détection de fuites :
 - méthode des bulles
 - agents de méthode fluorescents
- Si un travail à chaud doit être effectué sur l'équipement réfrigérant ou toute partie associée, un équipement d'extinction d'incendie approprié doit être disponible. Un extincteur à poudre chimique ou à CO₂ devrait être installé à proximité de la zone de chargement. Un extincteur chimique de classe B doit être disponible à tout moment.
- Il est interdit à toute personne effectuant des travaux en rapport avec un système réfrigérant qui impliquent la mise à nu d'une tuyauterie d'utiliser des sources d'inflammation de manière à entraîner un risque d'incendie ou d'explosion. Toutes les sources d'inflammation possibles, y compris la cigarette, doivent être suffisamment éloignées du site d'installation, de réparation, d'enlèvement et d'élimination, au cours desquels du réfrigérant peut éventuellement être libéré dans l'espace environnant. Avant d'entamer les travaux, la zone autour de l'équipement doit être étudiée pour s'assurer qu'il n'y a aucun risque d'inflammabilité ou d'inflammation. Des panneaux «Interdiction de fumer» doivent être affichés.
- Assurez-vous que la zone est à l'air libre ou qu'elle est correctement ventilée avant de pénétrer dans le système ou d'effectuer un travail à chaud. Un certain degré de ventilation doit être maintenu pendant la période où les travaux sont effectués. La ventilation doit permettre de disperser en toute sécurité tout réfrigérant libéré et, de préférence, de l'expulser dans l'atmosphère.

⚠ DANGER Continué

- Pour pénétrer dans le circuit du réfrigérant afin d'effectuer des réparations ou pour toute autre raison, des procédures conventionnelles doivent être utilisées. Toutefois, pour les réfrigérants inflammables, il est important de suivre les meilleures pratiques, car l'inflammabilité est un facteur à prendre en considération. La procédure suivante doit être respectée:
 - éliminer le réfrigérant en toute sécurité conformément aux réglementations locales et nationales
 - purger le circuit avec du gaz inerte
 - évacuer (en option pour A2L)
 - purger avec du gaz inerte (en option pour A2L)
 - ouvrir le circuit par coupure ou brasage
- Si une fuite est suspectée, toutes les flammes nues doivent être enlevées/éteintes.
- Si une fuite de réfrigérant nécessitant un brasage est constatée, tout le réfrigérant doit être récupéré dans le système ou isolé (au moyen de vannes d'arrêt) dans une partie du système éloignée de la fuite.
- Lors de l'élimination du réfrigérant d'un système, que ce soit pour l'entretien ou la mise hors service, il est recommandé de veiller à ce que tous les réfrigérants soient éliminés en toute sécurité.
- Lors du transfert de réfrigérant dans des bouteilles, veillez à ce que seules des bouteilles de récupération de réfrigérant appropriées soient utilisées. Assurez-vous que le nombre de bouteilles nécessaires pour contenir la charge totale du système est disponible. Toutes les bouteilles à utiliser sont désignées pour le réfrigérant récupéré et étiquetées pour ce réfrigérant (c'est-à-dire des bouteilles spéciales pour la récupération du réfrigérant). Les bouteilles doivent être équipées d'une soupape de surpression et de soupapes d'arrêt associées qui sont en bon état de fonctionnement. Les bouteilles de récupération vides sont évacuées et, si possible, refroidies avant la récupération.
- L'équipement de récupération doit être en bon état de fonctionnement, accompagné d'un ensemble d'instructions concernant l'équipement disponible et doit être adapté à la récupération de tous les réfrigérants appropriés, y compris, le cas échéant, les réfrigérants inflammables. En outre, un ensemble de balances étalonnées doit être disponible et en bon état de fonctionnement. Les tuyaux doivent être complets, équipés de raccords de déconnexion sans fuite et en bon état. Avant d'utiliser la machine de récupération, vérifiez qu'elle est en bon état de fonctionnement, qu'elle a été correctement entretenue et que tous les composants électriques associés sont scellés pour éviter toute inflammation en cas de fuite de réfrigérant. Consulter le fabricant en cas de doute.
- Le réfrigérant récupéré doit être renvoyé au fournisseur de réfrigérant dans la bouteille de récupération appropriée et le bon de transfert de déchets correspondant doit être établi. Ne mélangez pas les réfrigérants dans les unités de récupération et surtout pas dans les bouteilles.

⚠ DANGER Continué

- Si les compresseurs ou les huiles de compresseur doivent être retirés, assurez-vous qu'ils ont été évacués à un niveau acceptable afin de s'assurer qu'il ne reste pas de réfrigérant inflammable dans le lubrifiant. Le processus d'évacuation doit être effectué avant que le compresseur ne soit renvoyé aux fournisseurs. Seul le chauffage électrique du boîtier du compresseur doit être utilisé pour accélérer ce processus. Lorsque l'huile est vidangée d'un système, cette opération doit être effectuée en toute sécurité.
- En plus des procédures de charge conventionnelles, les exigences suivantes doivent être respectées :
 - S'assurer qu'aucune contamination de différents réfrigérants ne se produit lors de l'utilisation de l'équipement de charge. Les tuyaux ou conduites doivent être aussi courts que possible afin de minimiser la quantité de réfrigérant qu'ils contiennent.
 - Les bouteilles doivent être maintenues dans une position appropriée conformément aux instructions.
 - S'assurer que le système de réfrigération soit mis à la terre avant de charger le système avec du réfrigérant.
 - Étiqueter le système lorsque la charge est terminée (si cela n'a pas déjà été fait).
 - Il faut veiller à ne pas trop remplir le système de réfrigération.
- Avant de recharger le système, celui-ci doit être testé sous pression avec le gaz de purge approprié. Le système doit être soumis à un essai de fuite à la fin de la charge, mais avant la mise en service. Un test de contrôle de fuite doit être effectué avant de quitter le site.
- La réparation et l'entretien des composants électriques incluent les contrôles de sécurité initiaux et les procédures d'inspection des composants. En cas de défaut susceptible de compromettre la sécurité, aucune alimentation électrique ne doit être connectée au circuit tant que le problème n'a pas été résolu de manière satisfaisante. Si le défaut ne peut être corrigé immédiatement mais qu'il est nécessaire de poursuivre l'exploitation, une solution temporaire adéquate doit être utilisée. Cela doit être signalé au propriétaire de l'équipement, afin que toutes les parties soient informées.
- S'assurer que les condensateurs sont déchargés : cette opération doit être effectuée en toute sécurité afin d'éviter tout risque d'étincelle.
- S'assurer qu'aucun composant ou câblage électrique sous tension n'est exposé lors de la charge, de la récupération ou de la purge du système.
- S'assurer de la continuité de la mise à la terre.
- Lors des réparations de composants scellés, toutes les alimentations électriques doivent être déconnectées de l'équipement sur lequel on travaille avant tout retrait des couvercles scellés, etc. Si l'alimentation électrique de l'équipement est absolument nécessaire pendant l'entretien, un dispositif de détection des fuites fonctionnant en permanence doit être placé au point le plus critique afin de signaler en cas de situation potentiellement dangereuse.

⚠ DANGER Continué

- Lorsque des composants électriques sont remplacés, ils doivent être adaptés à l'usage prévu et répondre aux spécifications correctes. Les directives de maintenance et d'entretien de Hoshizaki America doivent être respectées à tout moment. En cas de doute, consulter le service d'assistance technique de Hoshizaki America pour obtenir de l'aide.
- S'assurer que la charge réelle de réfrigérant est conforme à la taille de la pièce dans laquelle les pièces contenant du réfrigérant sont installées.
- S'assurer que les dispositifs et les sorties de ventilation fonctionnent correctement et ne sont pas obstrués.
- S'assurer que le marquage de l'équipement est toujours visible et lisible. Les indications et les panneaux illisibles doivent être corrigés.
- S'assurer que les tuyaux ou les composants de réfrigération sont installés dans un endroit où ils ne risquent pas d'être exposés à une substance susceptible de corroder les composants contenant du réfrigérant, à moins que les composants ne soient construits avec des matériaux intrinsèquement résistants à la corrosion ou qu'ils ne soient protégés de manière appropriée contre la corrosion.
- Une attention particulière doit être accordée aux points suivants afin de s'assurer qu'en travaillant sur les composants électriques, le boîtier n'est pas altéré de manière à ce que le niveau de protection soit affecté. Il s'agit notamment des dommages causés aux câbles, du nombre excessif de connexions, des terminaux non conformes aux spécifications d'origine, des dommages causés aux joints et du montage incorrect des presse-étoupes, etc.
- S'assurer que l'appareil (boîtier de commande/composant) est solidement fixé.
- S'assurer que les joints ou les matériaux d'étanchéité ne sont pas dégradés au point de ne plus pouvoir empêcher la pénétration d'atmosphères inflammables. Les pièces de rechange doivent être conformes aux spécifications de Hoshizaki America.
- N'appliquez aucune charge inductive ou capacitive permanente au circuit sans vous assurer que celle-ci ne dépassera pas la tension et le courant autorisés pour l'équipement utilisé.
- Les composants à sécurité intrinsèque sont les seuls types de composants sur lesquels il est possible de travailler sous tension en présence d'une atmosphère inflammable. L'appareil d'essai doit être adapté à la puissance requise.
- Ne remplacer les composants que par des pièces spécifiées par Hoshizaki America. D'autres pièces peuvent entraîner l'inflammation du réfrigérant dans l'atmosphère à la suite d'une fuite.
- Vérifier que le câblage ne sera pas soumis à l'usure, à la corrosion, à une pression excessive, à des vibrations, à des arêtes vives ou à tout autre effet environnemental négatif. Le contrôle doit également prendre en compte les effets du vieillissement ou des vibrations continues provenant de sources telles que les compresseurs ou les ventilateurs.

B. Service Diagnosis



R-290 Class A3 Flammable Refrigerant Used

⚠ DANGER

Risk of Fire or Explosion. Flammable Refrigerant Used.

- Be sure to follow all Important Safety Information located at the beginning of this manual and at the beginning of section "III.A. Safety Precautions When Servicing."
- Servicing shall be done by trained service personnel with certified competence in handling flammable refrigerants to minimize the risk of possible ignition due to incorrect parts or improper service.

Risque De Feu Ou D'Explosion. Fluide Frigorigène Inflammable Utilisé.

- Assurez-vous de suivre toutes les informations importantes de sécurité qui se trouvent au début du présent manuel et au début de la section «III.A. Précautions de sécurité lors de l'entretien.»
- L'entretien doit être effectué par du personnel formé et certifié pour la manipulation de réfrigérants inflammables afin de réduire au minimum le risque d'inflammation dû à des pièces incorrectes ou à un entretien inadéquat.

⚠ WARNING

- Risk of electric shock. Use extreme caution and exercise safe electrical practices.
- Risk of electric shock. Control module in "OFF" position does not de-energize all loads.
- Press the "U" button on the control module for 1 sec. to turn the appliance off, then unplug the appliance from the electrical outlet before servicing.
- Moving parts (e.g., fan blade) can crush and cut. Keep hands clear.
- Make sure all food zones in the appliance are clean after service.

1. Refrigerator Diagnostic Procedures

These diagnostic procedures are a sequence of checks that allow you to diagnose the electrical system and components. Before proceeding, check for correct installation and proper voltage per nameplate. If the display is in alarm, see "III.H. Alarm Safeties."

Note: When checking voltage (115VAC), always choose a white (W) neutral wire to establish a good neutral connection.

- 1) Unplug the appliance from the electrical outlet.
- 2) Remove the front panel and side panel.

- 3) Plug the appliance back into the electrical outlet. If the appliance was in defrost when the power supply was disconnected, defrost is terminated and normal cooling cycle begins. **WARNING! To reduce the risk of electric shock, do not touch the plug with damp hands.**
- 4) **Startup/Cool Down**– Cabinet temperature appears on display, Comp and EvapFM icons turn on. Comp, ConFM, MH (equipment stands), and EvapFM energize.
Factory Default Temperature Setting: Setpoint: 36°F (1.7°C). For further details, see "III.E. Controls and Adjustments."
- a) **CM Diagnosis:** Cabinet temperature appears on display and Comp and EvapFM icons are on. If not, check for 115VAC at CM 7 line (BK) to CM 8 neutral (W). If 115VAC is not present, check power cord connections and breaker/fuse. Confirm wiring connections are secure for both CM 7 line (BK) (power supply) and CM 8 neutral (W). If 115VAC is present and display is off, replace CM.
- b) **Comp/ConFM Diagnosis:** Confirm Comp and ConFM energize. If not, check for 115VAC at CM 4 (BK) to neutral (W). If 115VAC is not present, check power cord connections and breaker/fuse. Confirm wiring connections are secure for both CM 4 line (BK) (power supply) and CM 8 neutral (W). If 115VAC is present at CM 4 (BK) to neutral (W), check for 115VAC at CM 3 (V) to neutral (W). If 115VAC is not present at CM 3 (V) to neutral (W), check CTh status. See "III.C. Thermistor Check." If CTh ohm reading is in proper range, replace CM. If ConFM is energized but Comp is not, check for 115VAC from both sides of Comp external protector to neutral (W). If 115VAC is present on one side and not the other, allow time for Comp external protector to cool and reset. If Comp external protector does not reset, replace Comp external protector. If 115VAC is present on both Comp external protector wires, check Comp run capacitor, PTC relay, and Comp motor windings. If ConFM is not energized, confirm 115VAC at ConFM. If 115VAC is not present, check wiring connections. If 115VAC is present, check ConFM fan blades for binding and motor winding continuity. If Comp and ConFM are energized and the cabinet does not cool down, check for a restriction in the refrigeration circuit and correct refrigerant charge.
- c) **EvapFM Diagnosis:** Confirm EvapFM icon is on and not flashing, and EvapFM energizes. If not, check for 115VAC at CM 5 (BK) to neutral (W). If 115VAC is not present, check power cord connections and breaker/fuse. Confirm wiring connections are secure. If 115VAC is present, check for 115VAC at CM 6 (DBU) to neutral (W). If 115VAC is not present at CM 6 (DBU), replace CM. If 115VAC is present at CM 6 (DBU) to neutral, check for a loose wire, EvapFM blades binding, and EvapFM continuity.
- d) **MH Diagnosis (equipment stands):** MH follows Comp operation. When Comp is energized, MH is energized. If 115VAC is present at CM 4 (BK), check amp draw of MH. If an amp reading is not present, check the continuity of MH. If defective, replace MH.

- 5) **Cool Down Achieved**—CTh cools to setpoint. EvapFM, Comp, MH (equipment stands), and ConFM de-energize. Comp and EvapFM icons turn off. Cabinet temperature displayed on CM.
Diagnosis: Confirm Comp and EvapFM icons turn off and Comp, ConFM, MH, and EvapFM de-energize. If not, and Comp and ConFM are energized longer than 2 min., check CTh status. See "III.C. Thermistor Check." If CTh ohm reading is in range and Comp and ConFM were energized longer than 2 min., check for 115VAC at CM 3 (V) to neutral (W). If 115VAC is present, replace CM.
- 6) **Defrost**— 6-hr. defrost timer or 4-hr. continuous Comp run timer terminates and DTh is at or lower than -4°F (-20°C), defrost starts. If on, Comp and EvapFM icons turn off. Comp, ConFM, MH (equipment stands), and EvapFM de-energize. The defrost icon turns on and "dEF" is displayed. There is a 1-hr. maximum defrost time, and a 6-hr., defrost interval.
- a) **Time-Initiation:** 6-hr., defrost interval timer or 4-hr. continuous Comp run timer terminates. CM checks DTh. If DTh is at or lower than -4°F (-20°C), defrost starts. If on, Comp and EvapFM icons turn off. Comp, ConFM, MH (equipment stands), and EvapFM de-energize. Defrost icon turns on and "dEF" is displayed. If DTh is greater than -4°F (-20°C), 6-hr. defrost timer and 4-hr. Comp continuous run timer resets and defrost is delayed until next 6-hr. defrost timer or 4-hr. Comp continuous run timer terminates. Once the defrost interval timer terminates, defrost starts. The maximum defrost time is 1 hr.
- b) **Manual-Initiation:** To initiate a manual defrost, press the up button for 5 sec. If on, Comp and EvapFM icons turn off. Comp, ConFM, MH (equipment stands), and EvapFM de-energize. Defrost icon turns on and "dEF" is displayed. Note: If DTh is greater than 45°F (7.2°C), manual defrost cannot initiate.
- c) **Defrost-Termination:**
- (1) DTh warms to 45°F (7.2°C). 1-min. Comp/ConFM delay timer and 2-min. EvapFM delay timer start. Defrost icon flashes and "Pdf" is displayed.
 - (2) Defrost icon turns off. "Pdf" is displayed until cabinet temperature achieves 2.7°F (1.5°C), above temperature setpoint. Once 2.7°F (1.5°C), above temperature setpoint is achieved, cabinet temperature returns to display. Comp icon turns on, and EvapFM icon starts flashing. Comp, MH (equipment stands), and ConFM energize. 6-hr. defrost interval timer resets.
 - (3) EvapFM icon turns solid and EvapFM energizes.

Defrost Diagnosis:

- a) **Time-Initiation:** Has 6-hr. defrost timer or 4-hr. Comp continuous run timer terminated? Before proceeding, confirm DTh status. See "III.C. Thermistor Check."
 - b) **Manual-Initiation:** Press the up button for 5 sec. and release. Note: The defrost thermistor must be below 45°F (7.2°C) to initiate a defrost cycle.
- 1) **Defrost Initiation:** Check the following:
 - (a) **CM Diagnosis:** Confirm defrost icon turns on, Comp and EvapFM icons turn off, and "dEF" replaces cabinet temperature on display. If not, replace CM.
 - (b) **Comp/ConFM/EvapFM/ and MH (equipment stands) Diagnosis:** Confirm Comp, ConFM, MH (equipment stands), and EvapFM de-energize. If not, check for 115VAC at CM 3 (V) to neutral (W) and CM 6 (DBU) to neutral (W). If 115VAC is present, replace CM.
 - 2) **Defrost-Termination:** There is a 1 hr. maximum defrost time. Confirm DTh status. See "III.C. Thermistor Check."
 - (a) **CM and DTh Diagnosis:** Has DTh warmed to 45°F (7.2°C). If DTh has not warmed to 45°F (7.2°C), check DTh. See "III.C. Thermistor Check." If DTh is in proper range, defrost icon starts flashing and "Pdf" is displayed on CM. 1-min. Comp/ConFM delay timer starts. If not, replace CM. If 45°F (7.2°C) is not achieved within 1 hr., CM terminates defrost.
 - (b) **Comp/ConFM/EvapFM/ and MH (equipment stands) Diagnosis:** 1-min. Comp/ConFM delay timer terminates. Defrost icon turns off. Comp icon turns on, and EvapFM icon starts flashing. Comp, MH (equipment stands), and ConFM energize. If not, check for 115VAC at CM 3 (V) to neutral (W). If 115VAC is not present, check CTh status. "III.C. Thermistor Check." If CTh ohm reading is in proper range, and Comp, MH (equipment stands), and ConFM do not energize, replace CM. If ConFM is not energized, check ConFM fan blades for binding and motor winding continuity. 3-min. EvapFM delay timer terminates (15-min. after Comp energizes). EvapFM icon turns solid and EvapFM energizes. If not, check 115VAC at CM 6 (DBU) to neutral (W). If 115VAC is not present and EvapFM icon is on, replace CM. If 115VAC is present, check for loose wiring, fan blades binding, and EvapFM winding continuity. Replace as needed. "Pdf" is displayed until cabinet temperature achieves 2.7°F (1.5°C) above temperature setpoint. Once 2.7°F (1.5°C) above temperature setpoint is achieved, cabinet temperature returns to display.
 - 3) **Manual Defrost-Termination:** To terminate a defrost cycle, press and hold the "Up" button on the control module.
 - (a) 1-min. Comp/ConFM delay timer and 2-min. EvapFM delay timer start. Defrost icon flashes and "Pdf" is displayed.
 - (b) Defrost icon turns off. "Pdf" is displayed until cabinet temperature achieves 2.7°F (1.5°C), above temperature setpoint. Once 2.7°F (1.5°C), above temperature setpoint is achieved, cabinet temperature returns to display. Comp icon turns on, and EvapFM icon starts flashing. Comp, MH (equipment stands), and ConFM energize. 6-hr. defrost interval timer resets.
 - (c) EvapFM icon turns solid and EvapFM energizes.

Legend: **CM**—control module; **Comp**—compressor; **ConFM**—condenser fan motor; **CTh**—cabinet thermistor; **DTh**—defrost thermistor; **EvapFM**—evaporator fan motors; **MH**—mullion heater

2. Freezer Diagnostic Procedures

These diagnostic procedures are a sequence of checks that allow you to diagnose the electrical system and components. Before proceeding, check for correct installation and proper voltage per nameplate. If the display is in alarm, see "III.H. Alarm Safeties."

Note: When checking voltage (115VAC), always choose a white (W) neutral wire to establish a good neutral connection.

- 1) Unplug the appliance from the electrical outlet.
- 2) Remove the front panel and side panel.
- 3) Plug the appliance back into the electrical outlet. If the appliance was in defrost when the power supply was disconnected, defrost is terminated and normal cooling cycle begins. **WARNING! To reduce the risk of electric shock, do not touch the plug with damp hands.**
- 4) **Startup/Cool Down**– Cabinet temperature appears on display, Comp and EvapFM icons turn on. Comp, ConFM, EvapFM, and MH and PH energize.
Factory Default Temperature Setting: Setpoint: 2°F (-16.7°C). For further details, see "III.E. Controls and Adjustments."
 - a) **CM Diagnosis:** Cabinet temperature appears on display and Comp and EvapFM icons are on. If not, check for 115VAC at CM 7 line (BK) to CM 8 neutral (W). If 115VAC is not present, check power cord connections and breaker/fuse. Confirm wiring connections are secure for both CM 7 line (BK) (power supply) and CM 8 neutral (W). If 115VAC is present and display is off, replace CM.
 - b) **Comp/ConFM/MH/PH Diagnosis:** Confirm Comp, ConFM, MH, and PH energize. If not, check for 115VAC at CM 4 (BK) to neutral (W). If 115VAC is not present, check power cord connections and breaker/fuse. Confirm wiring connections are secure for both CM 4 line (BK) (power supply) and CM 8 neutral (W). If 115VAC is present at CM 4 (BK) to neutral (W), check for 115VAC at CM 3 (V) to neutral (W). If 115VAC is not present at CM 3 (V) to neutral (W), check CTh status. See "III.C. Thermistor Check." If CTh ohm reading is in proper range, replace CM. If ConFM is energized but Comp is not, check for 115VAC from both sides of Comp external protector to neutral (W). If 115VAC is present on one side and not the other, allow time for Comp external protector to cool and reset. If Comp external protector does not reset, replace Comp external protector. If 115VAC is present on both Comp external protector wires, check Comp run capacitor, PTC relay, and Comp motor windings. If ConFM is not energized, confirm 115VAC at ConFM. If 115VAC is not present, check wiring connections. If 115VAC is present, check ConFM fan blades for binding and motor winding continuity. If Comp and ConFM are energized and the cabinet does not cool down, check for a restriction in the refrigeration circuit and correct refrigerant charge. If MH or PH do not energize, check continuity, replace as needed.
 - c) **EvapFM Diagnosis:** Confirm EvapFM icon is on and not flashing, and EvapFM energizes. If not, check for 115VAC at CM 5 (BK) to neutral (W). If 115VAC is not present, check power cord connections and breaker/fuse. Confirm wiring connections are secure. If 115VAC is present, check for 115VAC at CM 6 (DBU) to neutral (W). If 115VAC is not present at CM 6 (DBU), replace CM. If 115VAC is present at CM 6 (DBU) to neutral, check for a loose wire, EvapFM blades binding, and EvapFM continuity.

- 5) **Cool Down Achieved**—CTh cools to setpoint. EvapFM, Comp, ConFM, MH, and PH de-energize. Comp and EvapFM icons turn off. Cabinet temperature displayed on CM. **Diagnosis:** Confirm Comp and EvapFM icons turn off and Comp, ConFM, EvapFM, MH, and PH de-energize. If not, and Comp and ConFM are energized longer than 2 min., check CTh status. See "III.C. Thermistor Check." If CTh ohm reading is in range and Comp and ConFM were energized longer than 2 min., check for 115VAC at CM 3 (V) to neutral (W). If 115VAC is present, replace CM.
- 6) **Defrost**— 12-hr. defrost timer or 4-hr. continuous Comp run timer terminates and DTh is at or lower than -32°F (-35.5°C), defrost starts. If on, Comp and EvapFM icons turn off. Comp, ConFM, EvapFM, MH, and PH de-energize. The defrost icon turns on and "dEF" is displayed. DH energizes. There is a 1-hr. maximum defrost time, and a 12-hr. defrost interval.
- a) **Time-Initiation:** 12-hr. defrost interval timer or 4-hr. continuous Comp run timer terminates. CM checks DTh. If DTh is at or lower than -32°F (-35.5°C) defrost starts. If on, Comp and EvapFM icons turn off. Comp, ConFM, EvapFM, MH, and PH de-energize. Defrost icon turns on and "dEF" is displayed. DH energizes. If DTh is greater than -32°F (-35.5°C)(Frz), 12-hr. defrost timer and 4-hr. Comp continuous run timer resets and defrost is delayed until next 12-hr. defrost timer or 4-hr. Comp continuous run timer terminates. Once the defrost interval timer terminates, defrost starts. The maximum defrost time is 1 hr.
- b) **Manual-Initiation:** To initiate a manual defrost, press the up button for 5 sec. If on, Comp and EvapFM icons turn off. Comp, ConFM, EvapFM, MH, and PH de-energize. Defrost icon turns on and "dEF" is displayed. DH energizes. Note: If DTh is greater than 55°F (12.8°C), manual defrost cannot initiate.
- c) **Defrost-Termination:**
- (1) DTh warms to 55°F (12.8°C). DH de-energizes. 1-min. Comp/ConFM delay timer and 2-min. EvapFM delay timer start. Defrost icon flashes and "Pdf" is displayed during a 3-min. drip time.
 - (2) Defrost icon turns off. "Pdf" is displayed until cabinet temperature achieves 2.2°F (1.2°C) above temperature setpoint. Once 2.2°F (1.2°C) above temperature setpoint is achieved, cabinet temperature returns to display. Comp icon turns on, and EvapFM icon starts flashing. Comp, ConFM, MH, and PH energize. 12-hr. defrost interval timer resets.
 - (3) EvapFM icon turns solid and EvapFM energizes.

Defrost Diagnosis:

- a) **Time-Initiation:** Has 12-hr. defrost timer or 4-hr. Comp continuous run timer terminated? Before proceeding, confirm DTh status. See "III.C. Thermistor Check."
- b) **Manual-Initiation:** Press the up button for 5 sec. and release. Note: The defrost thermistor must be below 55°F (12.8°C) to initiate a defrost cycle.

- 1) **Defrost Initiation:** Check the following:
 - (a) **CM Diagnosis:** Confirm defrost icon turns on, Comp and EvapFM icons turn off, and "dEF" replaces cabinet temperature on display. If not, replace CM.
 - (b) **DH Diagnosis:** Confirm DH energizes. If not, check for 115VAC at CM 2 (R) to neutral (W). If 115VAC is not present, replace CM. If 115VAC is present, check DST continuity. If open, let cool and reset. If DST does not close, replace DST. If DST is closed, check DH amp draw and continuity.
 - (c) **Comp/ConFM/EvapFM/MH/PH Diagnosis:** Confirm Comp, ConFM, EvapFM, MH, and PH de-energize. If not, check for 115VAC at CM 3 (V) to neutral (W) and CM 6 (DBU) to neutral (W). If 115VAC is present at either location, replace CM.
- 2) **Defrost-Termination:** There is a 1 hr. maximum defrost time. Confirm DTh status. See "III.C. Thermistor Check."
 - (a) **CM, DTh, and DH Diagnosis:** Has DTh warmed to 55°F (12.7°C). If DTh has not warmed to 55°F (12.7°C), check DST and DH continuity. Next, check DH amp draw. If DTh is in proper range, DH de-energizes. If not, replace CM. Once DH de-energizes, defrost icon starts flashing and "Pdf" is displayed on CM. 1-min. Comp/ConFM delay timer starts. If not, replace CM. If 55°F (12.7°C) is not achieved within 1 hr., CM terminates defrost.
 - (b) **Comp/ConFM/EvapFM/MH/PH Diagnosis:** 1-min. Comp/ConFM delay timer terminates. Defrost icon turns off. Comp icon turns on, and EvapFM icon starts flashing. Comp, ConFM, MH, and PH energize. If not, check for 115VAC at CM 3 (V) to neutral (W). If 115VAC is not present, check CTh status. "III.C. Thermistor Check." If CTh ohm reading is in proper range, and Comp and ConFM do not energize, replace CM. If ConFM is not energized, check ConFM fan blades for binding and motor winding continuity. 3-min. EvapFM delay timer terminates (15-min. after Comp energizes). EvapFM icon turns solid and EvapFM energizes. If not, check 115VAC at CM 6 (DBU) to neutral (W). If 115VAC is not present and EvapFM icon is on, replace CM. If 115VAC is present, check for loose wiring, fan blades binding, and EvapFM winding continuity. Replace as needed. "Pdf" is displayed until cabinet temperature achieves 2.2°F (1.2°C) above temperature setpoint. Once 2.2°F (1.2°C) above temperature setpoint is achieved, cabinet temperature returns to display. Confirm MH or PH energize. If MH and PH do not energize, check for amperage. If no amperage, check continuity. If defective, replace MH/PH.
- 3) **Manual Defrost-Termination:** To terminate a defrost cycle, press and hold the "Up" button on the control module.
 - (a) DH de-energizes. 1-min. Comp/ConFM delay timer and 2-min. EvapFM delay timer start. Defrost icon flashes and "Pdf" is displayed during a 3-min. drip time.
 - (b) Defrost icon turns off. "Pdf" is displayed until cabinet temperature achieves 2.2°F (1.2°C) above temperature setpoint. Once 2.2°F (1.2°C) above temperature setpoint is achieved, cabinet temperature returns to display. Comp icon turns on, and EvapFM icon starts flashing. Comp, ConFM, MH, and PH energize. 12-hr. defrost interval timer resets.
 - (c) EvapFM icon turns solid and EvapFM energizes.

Legend: **CM**—control module; **Comp**—compressor; **ConFM**—condenser fan motor; **CTh**—cabinet thermistor; **DH**—defrost heater; **DST**—defrost safety thermostat; **DTh**—defrost thermistor; **EvapFM**—evaporator fan motors; **MH**—mullion heater; **PH**—perimeter heater

C. Thermistor Check

The cabinet thermistor is used for cabinet temperature control and the defrost thermistor is used for defrost cycle assisted initiation:

Cabinet Thermistor -

Refrigerator: -4°F (-20°C)

Freezer: -32°F (-35.5°C)

Defrost Thermistor -

Refrigerator: 45°F (7.2°C)

Freezer: 55°F (12.8°C)

Thermistor resistance varies depending on temperature.

The control module monitors the thermistors to control system operation. No adjustment is required.

To check thermistor resistance, follow the steps below.

- 1) Unplug the appliance.
- 2) Remove the front panel.
- 3) Disconnect and remove the thermistor in question.
- 4) Immerse the thermistor sensor portion in a glass containing ice and water for 2 to 3 min.
- 5) Check the resistance between the wires at the thermistor connector. Normal reading is within 24 to 27 kΩ. If outside the normal reading, replace the thermistor.
- 6) Reconnect and replace the thermistor in its correct position.
- 7) Plug the appliance back in.

D. Diagnostic Table

Check for correct appliance installation per the instruction manual and proper voltage per appliance nameplate.

1. Appliance Not Cooling

Appliance Not Cooling - Possible Cause	
1. Power Supply	a) Unplugged, blown fuse, or tripped or defective circuit breaker.
	b) Loose connection.
	c) Not within specifications.
2. Power Cord and Plug	a) Loose connection.
	b) Defective.
3. Wiring	a) Loose connection or open.
	b) Faulty.
4. Control Module See "III.H. Alarm Safeties."	a) In alarm.
	b) Defective.
5. Compressor External Protector	a) Dirty condenser.
	b) Condenser fan not operating.
	c) Defective.
	d) Start relay defective.
	e) Low charge.
	f) Start capacitor (if applicable) defective.
6. Compressor	a) Defective.
7. Condenser	a) Dirty.
8. Evaporator Fan	a) Defective.
	b) Fan blade binding.
9. Evaporator	a) Dirty or frozen up. See "III.D.2. Evaporator is Frozen Up."
10. Refrigerant Lines	a) Gas leak.
	b) Refrigerant lines or components restricted.
11. Defrost Heater (Freezer)	a) Control module defective.

2. Evaporator is Frozen Up

Evaporator is Frozen Up - Possible Cause	
1. Evaporator	a) Dirty.
2. Evaporator Fan Motor	a) Defective.
	b) Fan blade binding.
	c) Defrost thermistor defective.
	d) Control module defective.
3. Defrost Thermistor	a) Out of position or defective.
4. Control Module	a) Defective.
5. Refrigerant Charge/Refrigerant Lines	a) Low.
	b) Component restriction (cap tube, drier).
6. Defrost Heater (Freezer)	a) Defective.
7. Defrost Safety Thermostat (Freezer)	a) Defective.

3. Defrost Fails to Initiate or Terminate

Defrost Fails to Initiate - Possible Cause		
1.	Refrigerator: Defrost Thermistor (Confirm DTh status. See "III.C. Thermistor Check.")	a) Evaporator temperature at or higher than 45°F (7.2°C). See "III.D.1. Appliance Not Cooling."
		b) Out of position or defective.
2.	Freezer: Defrost Thermistor (Confirm DTh status. See "III.C. Thermistor Check.")	a) Evaporator temperature at or higher than 55°F(12.8°C). See "III.D.1. Appliance Not Cooling."
		b) Out of position or defective.
3.	Control Module	a) Defective control module.
		b) Refrigerator: 6-hr. defrost timer or 4-hr. compressor continuous run timer.
		c) Freezer: 12-hr. defrost timer or 4-hr. compressor continuous run timer.
Defrost Fails to Terminate - Possible Cause		
1.	Refrigerator: Defrost Thermistor (Confirm DTh status. See "III.C. Thermistor Check.")	a) Evaporator temperature 45°F (7.2°C) not achieved.
		b) Defective.
	Freezer: Defrost Thermistor (Confirm DTh status. See "III.C. Thermistor Check.")	a) Evaporator temperature 55°C (12.8°C) not achieved.
		b) Defective.
2.	Defrost Safety Thermostat (Freezer)	a) Defective.
3.	Defrost Heater (Freezer)	a) Defective.
4.	Control Module	a) Defective.

E. Controls and Adjustments

1. Control Module

When the power cord is plugged in there is a slight delay, then the current cabinet temperature is displayed. From the control module, the cabinet setpoint and temperature display scale can be changed.

All models are pretested and factory set.

NOTICE

- The control module is fragile, handle very carefully.
- Do not change wiring and connections. Never misconnect terminals.
- Do not short out power supply to test for voltage.

2. Control Module Display Layout

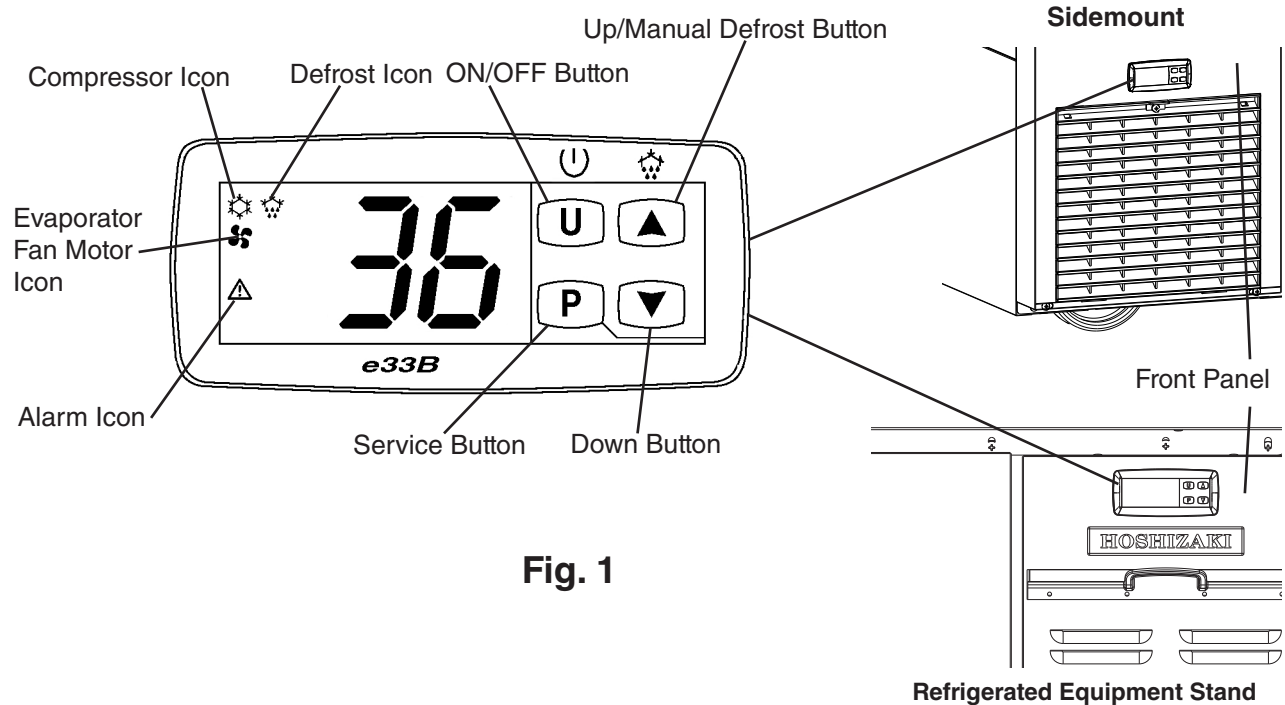

Fig. 1

3. Control Module Rear Layout

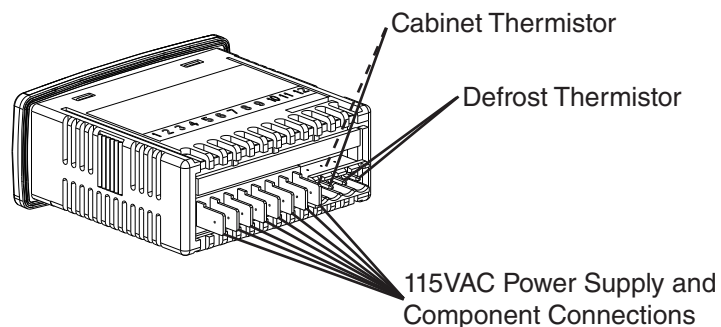

Fig. 2

4. Control Module Electrical Layout

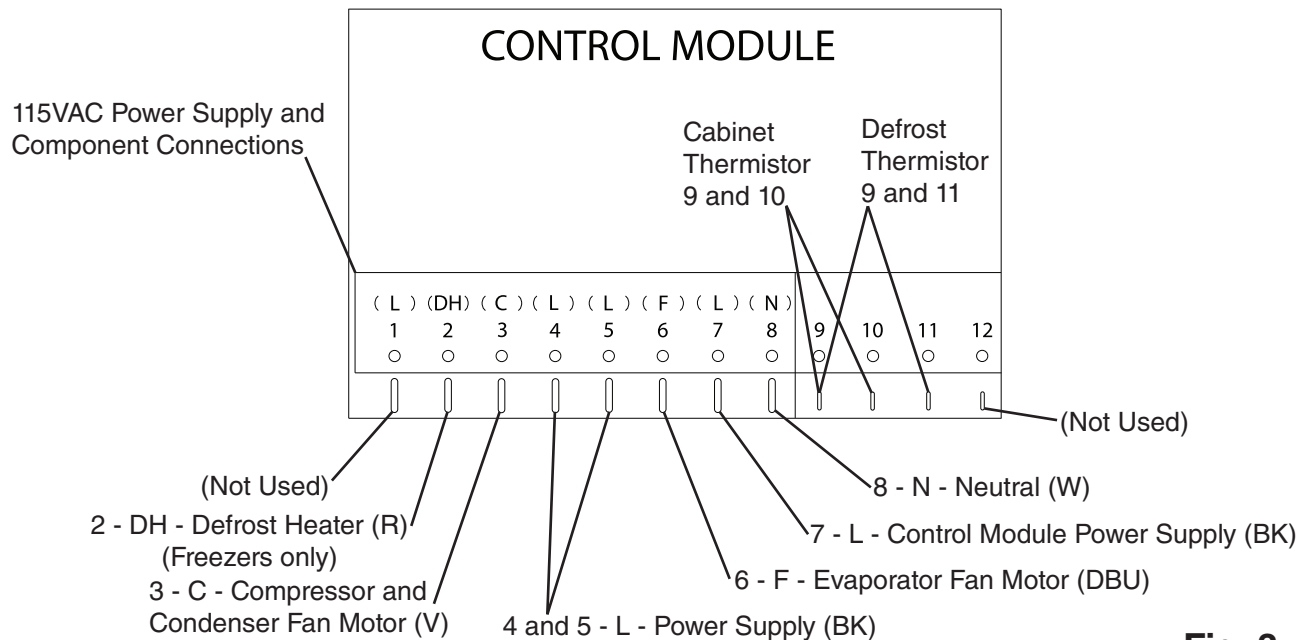

Fig. 3

5. Control Module Display Icons

Control module icons inform you of energized components and if the appliance is in alarm. Note: Icons flash when component is called for during a timed lockout. Once the timer terminates, the icon goes solid and component energizes.

Control Module Icons	
Icon	Meaning
	Compressor Flashing: Refrigerator: Compressor waiting for 2-min. compressor delay timer to terminate. Freezer: Compressor waiting for 3.5-min. compressor delay timer to terminate. Solid: Compressor energized.
	Defrost Flashing: Drip Time (compressor delay) Solid: Appliance is in defrost cycle. See "III.G. Defrost" for details.
	Evaporator Fan Motor Flashing: Refrigerator: Evaporator fan motor waiting for 2-min. evaporator fan motor delay timer to terminate. Freezer: Evaporator fan motor waiting for 3.5-min. evaporator fan motor delay timer to terminate. Solid: Evaporator fan motor energized.
	Alarm Appliance is in alarm. See "III.H. Alarm Safeties" for details.

F. Temperature

1. Default Temperature Settings

The default CM setpoint is as follows:

Refrigerator: 36°F (2.2°C)

Freezer: 2.0°F (-16.7°C)

The default CM display scale setting is °F.

2. Adjusting the Temperature Setpoint

The temperature setpoint is the value for the cabinet temperature. The temperature differential for the compressor to turn on is:

Refrigerator: ±2.7°F (±1.5°C) of the temperature setpoint.

Freezer: ±2.2°F (±1.2°C) of the temperature setpoint.

The compressor turns off at setpoint. For example, for a refrigerator temperature setpoint of 34°F (1.1°C), the compressor turns on at 36.7°F (2.6°C) and the compressor turns off at 31.3°F (-0.4°C).

If necessary, adjust the temperature setpoint temperature as follows:

To change the temperature setpoint, press the up or down button briefly and then release. SP1 flashes for a few seconds, then the current temperature setpoint appears. Press the up or down button until the desired value is displayed. After 10 seconds or the "P" button is pressed, the display returns to the current cabinet temperature and the temperature setpoint is saved.

Model	Temperature Setpoint Range	Factory Default Temperature Setting
Refrigerator	28°F to 45°F (-2.2°C to 7.2°C)	36°F (2.2°C)
Freezer	-12°F to 10°F (-24.4°C to -12.2°C)	2.0°F (-16.7°C)

NOTICE! Do not adjust the temperature setpoint more than 2°F (1°C) at a time. Allow the temperature to stabilize for a minimum of 8 hours before making further temperature setpoint adjustments.

3. Cabinet Temperature Display Scale (°F or °C)

There are 4 temperature display settings from which to choose.

The factory temperature display default is F0 for °F whole number.

For a whole number temperature display scale value, select F0 or C0.

For a temperature display scale value to one decimal point, select F1 or C1.

Display Scale	Temperature Display Style
F0 - Factory Default	36°F
C0	2°C
F1	36.0°F
C1	2.2°C

To change the temperature display scale value, follow the steps below:

- 1) Press the "U" and "P" buttons together for 5 seconds. .uP is displayed.
- 2) Press the "P" button. The current display setting (F0, F1, C0, or C1) and .uP start flashing.
- 3) Press the up or down button until the desired temperature display style is displayed.
- 4) Press the "P" button to save the selection. .uP is displayed. To return to normal display mode, press and hold the "U" button for 5 sec. Display returns to normal display mode. If no other button is pressed after pressing the "P" button, 25 sec. later, display returns to normal display mode.

Note: If no selection is saved within 30 seconds, the display returns to normal mode and the temperature display scale remains unchanged.

G. Defrost

DANGER

Risk of Fire or Explosion. Flammable Refrigerant Used.

- Do not use mechanical devices to defrost.
- Do not puncture refrigerant tubing. Risk of fire or explosion due to puncture of refrigerant tubing; follow handling instructions carefully.

Risque De Feu Ou D'Explosion. Fluide Frigorigène Inflammable Utilisé.

- Ne pas utiliser d'appareils mécaniques pour dégivrer le réfrigérateur.
- Ne pas perforer la tubulure contenant le frigorigène. Risque de feu ou d'explosion si la tubulure contenant le frigorigène est perforée; suivre les instructions de manutention avec soin.

1. Automatic Defrost

Off-Cycle Defrost: Refrigerators defrost naturally between run cycles and have a temperature or time initiated defrost cycle.

Note: There is a 1-hr. defrost lock-out after a defrost cycle terminates. This may be bypassed by initiating a manual defrost or unplugging and plugging back in to the electrical outlet.

- Temperature Initiated:
 - a) **Refrigerator:** When the defrost thermistor is at or below -4°F (-20°C)(Ref), defrost starts.
 - b) **Freezer:** When the defrost thermistor is at or below -32°F (-35.5°C), defrost starts.
- Time Initiated:
 - a) **Refrigerator:** Cumulative Compressor Run Time: Once the 6-hr. Cumulative Compressor Run Timer terminates, defrost starts.
 - b) **Freezer:** Cumulative Compressor Run Time: Once the 12-hr. Cumulative Compressor Run Timer terminates, defrost starts.
 - c) Continuous Compressor Run Time: Once the 4hr. Continuous Compressor Run Timer terminates, defrost starts.
- When defrost initiates, the maximum 1-hr. defrost timer starts. Compressor and condenser fan motor de-energize.
Refrigerator: Evaporator fan motor remains energized.
Freezer: Evaporator fan motor de-energizes.
- **Refrigerator:** When the defrost thermistor reaches 45°F (7.2°C), or the maximum 1-hr. defrost timer terminates, defrost terminates. Evaporator fan motor remains energized and compressor and condenser fan motor energize.
- **Freezer:** When the defrost thermistor reaches 55°F (12.7°C), or the maximum 1-hr. defrost timer terminates, defrost terminates. DH de-energizes and the Evaporator fan motor, compressor, and condenser fan motor energizes.

2. Manual Defrost

To initiate a manual defrost, press and hold the up button for 5 seconds.

To terminate a defrost, press and hold the up button for 5 seconds.

Note: Manual defrost only initiates when evaporator temperature (defrost thermistor) is at or below 45°F (7.2°C) for refrigerators and 56°F (13.3°C) for freezers.

H. Alarm Safeties

Alarm signals are designed to protect the appliance and food product. These alarms give information or warnings in the event the appliance is operating out of acceptable parameters. Should one of the alarms occur, follow the instructions in the table below to address the alarm. The alarm code and alarm icon flash with audible alarm.

Alarm Signals		
Alarm Code	Problem	Corrective Action/Reset Details
(-)E1	Cabinet Thermistor Malfunction Alarm Cabinet thermistor has failed.	Steady tone. To silence the alarm, press and release any button. Refrigerator: Appliance cycles 4 min. on, 6 min. off. Freezer: Appliance cycles 6 min. on, 3 min. off. -E1 - Cabinet thermistor out of place or open. E1 - Cabinet thermistor shorted.
(-)E2	Defrost Thermistor Malfunction Alarm Defrost thermistor has failed.	Steady tone. To silence the alarm, press and release any button. Appliance cycles on and off with cabinet thermistor. Refrigerator: Defrost cycles for 20 min. every 12 hrs. Freezer: Defrost cycles for 15 min. every 5 hrs. -E2 - Defrost thermistor out of place or open. E2 - Defrost thermistor shorted.
Hi	High Temperature Alarm Refrigerator: Cabinet temperature has remained above 53°F (11.6°C) for more than 1 hour. Freezer: Cabinet temperature has remained above 32°F (0°C) for more than 1 hour.	If obvious corrections such as closing drawers and cleaning the air filter and/or condenser do not bring temperature back in range, see "III.B.1. Diagnostic Procedures" and "III.D. Diagnostic Table." Steady tone. To silence the alarm and clear "Hi" from the display, press and release any button. The alarm icon stays on. Automatically resets when temperature returns to normal.
Lo	Low Temperature Alarm Refrigerator: Cabinet temperature has remained below 20°F (-6.7°C) for more than 1 hour. Freezer: Cabinet temperature has remained below -30°F (-34.4°C) for more than 1 hour.	If obvious corrections do not bring the temperature back in range, see "III.B.1. Diagnostic Procedures" and "III.D. Diagnostic Table." Steady tone. To silence the alarm and clear "Lo" from the display, press and release any button. The alarm icon stays on. Automatically resets when temperature returns to normal.
UHi	High Voltage Alarm (140VAC±5% or more)	The compressor de-energizes if voltage protection operates. The voltage safeties automatically reset when voltage is corrected.
ULo	Low Voltage Alarm (100VAC±5% or less)	

I. Safety Devices

1. Compressor External Protector

If combined temperature/amperage value is above the limit specified by the compressor manufacturer, the compressor protector operates independently to turn off the compressor. The compressor protector de-energizes the compressor until the temperature/amperage value returns to an acceptable level.

IV. Refrigeration Circuit and Component Service Information

⚠ DANGER

Risk of Fire or Explosion. Flammable Refrigerant Used

- Follow handling instructions carefully in compliance with U.S. government regulations.
- Do not use mechanical devices to defrost.
- Do not puncture refrigerant tubing. Risk of fire or explosion due to puncture of refrigerant tubing; follow handling instructions carefully.
- Component parts shall be replaced with like components.
- Servicing shall be done by factory authorized service personnel to minimize the risk of possible ignition due to incorrect parts or improper service.
- Consult instruction manual/service manual before attempting to install or service this product.
- Dispose of properly in accordance with federal or local regulations.
- Do not place any potential ignition sources in or near the appliance.

Risque De Feu Ou D'Explosion. Fluide Frigorigène Inflammable Utilisé.

- Suivre attentivement les instructions de manipulation conformément à la réglementation gouvernementale.
- Ne pas utiliser d'appareils mécaniques pour dégivrer le réfrigérateur.
- Ne pas perforer la tubulure contenant le frigorigène. Risque de feu ou d'explosion si la tubulure contenant le frigorigène est perforée; suivre les instructions de manutention avec soin.
- Les pièces des composants doivent être remplacées par des pièces et accessoires équivalents.
- L'entretien doit être effectué par le personnel de service autorisé par le fabricant afin de minimiser les risques d'inflammation attribuables à l'installation d'une pièce inadéquate ou à la mauvaise exécution du service.
- Consulter le manuel du propriétaire/guide de réparation avant de tenter une réparation. Toutes les mesures de sécurité doivent être respectées.
- Éliminer conformément aux règlements fédéraux ou locaux.
- Ne placez aucune source d'inflammation potentielle dans ou près de l'appareil.

⚠ WARNING

- Wear appropriate personal protective equipment (PPE) when servicing the appliance.
- Technician must utilize a combustible gas leak detector at all times.
- Notify everyone in the immediate area that you are working with flammable refrigerant.
- Do not work on appliance in a confined space. Confirm area is well ventilated.
- Identify and eliminate all possible ignition points in a 10 ft. (3 m) area around service area.
- Do not use mechanical devices to defrost.
- Use non-sparking tools.
- Class B dry chemical fire extinguisher or equivalent must be available.
- Do not pressurize system above 200 PSIG during leak check procedure or prior to evacuating refrigeration system.
- This appliance should be diagnosed and repaired only by qualified service personnel to reduce the risk of death, electric shock, serious injury, or fire.
- To reduce the risk of electric shock, do not touch the plug with damp hands.
- Unplug the appliance from the electrical outlet before servicing.
- Make sure all food zones in the appliance are clean after the appliance is serviced.

A. Refrigeration Circuit Service Information

WARNING

- Repairs requiring the refrigeration circuit to be opened must be performed by properly trained and EPA-certified service personnel.
- Use an electronic leak detector or soap bubbles to check for leaks. Add a trace of refrigerant to the system (if using an electronic leak detector), and then raise the pressure using nitrogen gas (140 PSIG). Do not use R-290 as a mixture with pressurized air for leak testing.

NOTICE

- Always recover the refrigerant and store it in an approved container. Do not discharge the refrigerant into the atmosphere.
- Do not leave the system open for longer than 15 minutes when replacing or servicing parts. The Polyol Ester (POE) oils used in R-290 appliances can absorb moisture quickly. Therefore it is important to prevent moisture from entering the system when replacing or servicing parts.
- Always install a new drier every time the sealed refrigeration system is opened. Do not replace the drier until after all other repair or replacement has been made. Install the new drier with the arrow on the drier in the direction of the refrigerant flow.
- When brazing, protect the drier by using a wet cloth to prevent the drier from overheating. Do not allow the drier to exceed 250°F (121°C).

Refrigerant leaks must be repaired as soon as they are discovered. If not, refrigerant charge should be recovered from the system until the leak can be repaired.

When repairing a leak:

- Repair the leak properly – Remove the refrigerant, examine the leak source, determine the reason for the leak, and carry out the proper course of action.
- Before repairing the leak, ensure that the refrigerant has been recovered and the system purged with nitrogen when brazing.
- Be sure to remove piercing valves attached to the system after repairs are made.

a) Refrigerant Recovery

Using proper refrigerant practices, place piercing valves toward the end (crimped area) of the high and low-side process tubes, then recover the refrigerant into an approved container or device.

- 1) Press the "U" button for 1-sec. to turn the control module off, then unplug the appliance from the electrical outlet.

b) Brazing

- 2) Prior to brazing, purge with nitrogen gas for 2 min., flowing at a pressure of 3 to 5 PSIG.
⚠ DANGER! For appliances containing flammable refrigerants, the system shall be purged with oxygen-free nitrogen to render the appliance safe for flammable refrigerants. This process might need to be repeated several times. Compressed air or oxygen shall not be used for purging refrigerant systems.
- 3) Braze/repair/replace damaged component or fittings while purging with nitrogen gas, flowing at a pressure of 3 to 5 PSIG.
- 4) Use soap bubbles to check for leaks. Raise the pressure using nitrogen gas (190 PSIG). Do not use any refrigerant as a mixture with pressurized air for leak testing.
- 5) Once leak checking is complete, release the nitrogen gas from the system.

c) Evacuation

- 6) Attach a vacuum pump to the system. Be sure the high-side charging hose is connected to the field-installed high-side access valve.

<i>IMPORTANT</i>
The vacuum level and vacuum pump may be the same as those for current refrigerants. However, the rubber hose and gauge manifold to be used for evacuation and refrigerant charge should be exclusively for POE oils.

- | |
|--|
| The vacuum level and vacuum pump may be the same as those for current refrigerants. However, the rubber hose and gauge manifold to be used for evacuation and refrigerant charge should be exclusively for POE oils. |
|--|
- 7) Turn on the vacuum pump, then open the high-side valve on the gauge manifold. Never allow the oil in the vacuum pump to flow backwards.
 - 8) Allow the vacuum pump to pull down to a 29.9" Hg vacuum. Evacuating period depends on pump capacity.
 - 9) Close the high-side valve on the gauge manifold.
 - 10) Disconnect the gauge manifold hose from the vacuum pump and attach it to a refrigerant service cylinder. Remember to loosen the connection and purge the air from the hose. See the nameplate for the required refrigerant charge. Hoshizaki recommends only virgin refrigerant or reclaimed refrigerant which meets the requirements of AHRI Standard 700 (latest edition) be used.

d) Recharge

DANGER

- In addition to conventional charging procedures, the following requirements shall be followed:
 - Ensure that contamination of different refrigerants does not occur when using charging equipment. Hoses or lines shall be as short as possible to minimize the amount of refrigerant contained in them.
 - Cylinders shall be kept in an appropriate position according to the instructions.
 - Ensure that the refrigerating system is earthed (grounded) prior to charging the system with refrigerant.
 - Label the system when charging is complete (if not already).
 - Extreme care shall be taken not to overfill the refrigerating system.
- The system shall be leak-tested on completion of charging but prior to commissioning. A follow up leak test shall be carried out prior to leaving the site.

- En plus des procédures de charge conventionnelles, les exigences suivantes doivent être respectées :
 - S'assurer qu'aucune contamination de différents réfrigérants ne se produit lors de l'utilisation de l'équipement de charge. Les tuyaux ou conduites doivent être aussi courts que possible afin de minimiser la quantité de réfrigérant qu'ils contiennent.
 - Les bouteilles doivent être maintenues dans une position appropriée conformément aux instructions.
 - S'assurer que le système de réfrigération soit mis à la terre avant de charger le système avec du réfrigérant.
 - Étiqueter le système lorsque la charge est terminée (si cela n'a pas déjà été fait).
 - Il faut veiller à ne pas trop remplir le système de réfrigération.
- Avant de recharger le système, celui-ci doit être testé sous pression avec le gaz de purge approprié. Le système doit être soumis à un essai de fuite à la fin de la charge, mais avant la mise en service. Un test de contrôle de fuite doit être effectué avant de quitter le site.

- 11) R-290 can be charged in either the liquid or vapor state. Liquid charge is preferred. If refrigerant charging is done in the liquid state, place the service cylinder on the scales; **if the service cylinder is not equipped with a dip tube, invert the service cylinder, then place it on the scales.** Open the high-side valve on the gauge manifold
- 12) Allow the system to charge with liquid until the proper charge weight is met.
- 13) Close the high-side valve on the gauge manifold. If charging is complete, skip to step 10.

- 14) If necessary, add any remaining charge to the system through the low-side.
NOTICE! To prevent compressor damage, use a throttling valve or liquid dispensing device to add the remaining liquid charge through the low-side refrigerant access valve with the compressor running. Close the refrigerant cylinder valve and let the low-side refrigerant equalize to the system, then close the low-side manifold gauge.
- 15) Pinch off (crimp down) the process tubes just below the piercing valves.
- 16) Remove the piercing valves. Cut the process tubes to remove the piercing valve holes.
- 17) Confirm there are no leaks from the pinched off process tubes, then braze the process tubes closed. **▲ DANGER! Be sure there is no refrigerant leak before brazing.**
- 18) Use a combustible gas leak detector or soap bubbles to check for leaks again.
- 19) Place red sleeves over the process tubes.
- 20) Plug the appliance back into the electrical outlet

B. Component Service Information



R-290 Class A3 Flammable Refrigerant Used

⚠ DANGER

Risk of Fire or Explosion. Flammable Refrigerant Used.

- Be sure to follow all Important Safety Information located at the beginning of this manual and at the beginning of section "III.A. Safety Precautions When Servicing."
- Component parts shall be replaced with like components. So as to minimize the risk of possible ignition due to incorrect parts.
- This appliance should be diagnosed and repaired only by qualified service personnel to reduce the risk of death, electric shock, serious injury, or fire.
- Repair and maintenance to electrical components shall include initial safety checks and component inspection procedures. If a fault exists that could compromise safety, then no electrical supply shall be connected to the circuit until it is satisfactorily dealt with. If the fault cannot be corrected immediately but it is necessary to continue operation, an adequate temporary solution shall be used. This shall be reported to the owner of the equipment, so all parties are advised.
- Confirm that capacitors are discharged: this shall be done in a safe manner to avoid possibility of sparking.
- Confirm that no live electrical components and wiring are exposed while charging, recovering, or purging the system.
- Confirm that there is continuity of earth bonding (grounding).

⚠ DANGER Continué

Risque D'Incendie ou D'Explosion. Fluide Frigorigène Inflammable Utilisé.

- Assurez-vous de suivre toutes les informations importantes de sécurité qui se trouvent au début du présent manuel et au début de la section «III.A. Précautions de sécurité lors de l'entretien.»
- Les pièces doivent être remplacées par des pièces similaires, de manière à réduire au minimum le risque d'inflammation dû à des pièces incorrectes.
- Cet appareil ne doit être diagnostiqué et réparé que par un personnel qualifié afin de réduire les risques de mort, d'électrocution, de blessures graves ou d'incendie.
- La réparation et l'entretien des composants électriques incluent les contrôles de sécurité initiaux et les procédures d'inspection des composants. En cas de défaut susceptible de compromettre la sécurité, aucune alimentation électrique ne doit être connectée au circuit tant que le problème n'a pas été résolu de manière satisfaisante. Si le défaut ne peut être corrigé immédiatement mais qu'il est nécessaire de poursuivre l'exploitation, une solution temporaire adéquate doit être utilisée. Cela doit être signalé au propriétaire de l'équipement, afin que toutes les parties soient informées.
- S'assurer que les condensateurs sont déchargés : cette opération doit être effectuée en toute sécurité afin d'éviter tout risque d'étincelle.
- S'assurer qu'aucun composant ou câblage électrique sous tension n'est exposé lors de la charge, de la récupération ou de la purge du système.
- S'assurer de la continuité de la mise à la terre.

NOTICE

When replacing a component listed below, see the notes to help ensure proper operation.

Component	Notes
Compressor	Install a new start relay and compressor external protector. WARNING! To reduce the risk of electric shock, be sure to reconnect the compressor's ground wire.

V. Maintenance

This appliance must be maintained in accordance with the instruction manual and labels provided with the appliance. Consult with your local Hoshizaki Certified Service Representative about maintenance service.

WARNING

- Only qualified service technicians should service this appliance.
- Failure to install, operate, and maintain the appliance in accordance with this manual will adversely affect safety, performance, component life, and warranty coverage.
- Press the "U" button for 1-sec. to turn the control module off, then unplug the appliance from the electrical outlet.
- To reduce the risk of electric shock, do not touch the control module or plug with damp hands.
- After service, make sure that there are no wires pinched between the panels and appliance. Make sure you do not damage the power cord

A. Maintenance Schedule

The maintenance schedule below is a guideline. More frequent maintenance may be required depending on water quality, the appliance's environment, and local sanitation regulations.

Maintenance Schedule		
Frequency	Area	Task
Bi-Weekly	Air Filters	Inspect. Wash with warm water and neutral cleaner if dirty.
Bi-Yearly	Condenser	Inspect. Clean if necessary by using a brush or vacuum cleaner. More frequent cleaning may be required depending on location.

VI. Preparing the Appliance for Periods of Non-Use

DANGER

Risk of Fire or Explosion. Flammable Refrigerant Used.

- Be sure to follow all Important Safety Information located at the beginning of this manual and at the beginning of section "III.A. Safety Precautions When Servicing."
- Only qualified service technicians should service this appliance.
- The appliance shall be stored in an area where the room size corresponds to the room area as specified for operation. See the nameplate or instruction manual for Minimum Room Floor Area.
- The appliance shall be stored in a room without continuously operating open flames (for example an operating gas appliance) or other potential ignition sources (for example an operating electric heater, hot surfaces).

Risque D'Incendie ou D'Explosion. Fluide Frigorigène Inflammable Utilisé.

- Assurez-vous de suivre toutes les informations importantes de sécurité qui se trouvent au début du présent manuel et au début de la section «III.A. Précautions de sécurité lors de l'entretien.»
- Seuls des techniciens de service qualifiés doivent installer et entretenir l'appareil.
- L'appareil doit être conservé dans une zone où la taille de la pièce correspond à la surface de la pièce spécifiée pour le fonctionnement.
- L'appareil doit être entreposé dans un local ne contenant pas de sources d'inflammation permanentes (flammes nues, appareil à gaz ou dispositif de chauffage électrique en fonctionnement, par exemple).

WARNING

When preparing the appliance for long storage, prevent the drawers from closing to reduce the risk of children getting trapped.

NOTICE

When preparing the appliance for long storage, clean the appliance. See the instruction manual for cleaning details.

- 1) Before shutting down the appliance, move all foods into another clean refrigerator or freezer.
- 2) Unplug the appliance. **WARNING! To reduce the risk of electric shock, do not touch the plug with damp hands.**

VII. Disposal and Decommissioning

DANGER

Risk of Fire or Explosion. Flammable Refrigerant Used.

- Follow handling instructions carefully in compliance with U.S. government regulations.
- Do not puncture refrigerant tubing. Risk of fire or explosion due to puncture of refrigerant tubing; follow handling instructions carefully.
- Dispose of properly in accordance with federal or local regulations.

Risque De Feu Ou D'Explosion. Fluide Frigorigène Inflammable Utilisé.

- Suivre attentivement les instructions de manipulation conformément à la réglementation gouvernementale.
- Ne pas perforer la tubulure contenant le frigorigène. Risque de feu ou d'explosion si la tubulure contenant le frigorigène est perforée; suivre les instructions de manutention avec soin.
- Éliminer conformément aux règlements fédéraux ou locaux.

WARNING

When preparing the appliance for disposal, remove the drawers to reduce the risk of children getting trapped.

The appliance contains refrigerant and must be disposed of in accordance with applicable national, state, and local codes and regulations. Refrigerant must be recovered by properly certified service personnel.

VIII. Technical Information

A. Electrical and Refrigerant Data

1. Sidemount Refrigerator and Freezer

Model	AC Supply Voltage	Amperes	Design Pressure (PSIG)		Refrigerant g (oz.)
			HIGH	LOW	R-290
_LR46B(-D2)(-L) _LR60B(-D2)(-D4) _LR67B(-D2)(-D4)	115/60/1	3	360	190	62 (2.2)
_LR93B(-D2)(-D4)(-D6)	115/60/1	5	360	190	68 (2.4)
_LF46B	115/60/1	4	360	190	75 (2.6)
_LF60B _LF67B	115/60/1	5	360	190	80 (2.8)

2. Equipment Stand Refrigerator and Freezer

Model	AC Supply Voltage	Amperes	Design Pressure (PSIG)		Refrigerant g (oz.)
			HIGH	LOW	R-290
CR36B(-L) CR49B(-L) CR60B(-L)	115/60/1	3	360	190	68 (2.4)
CR72B(-L) CR85B(-L)	115/60/1	3	360	190	88 (3.1)
CR98B(-L) CR110B(-L)	115/60/1	3	360	190	120 (4.2)
CF36B(-L) CF49B(-L) CF60B(-L) CF72B(-L)	115/60/1	4	360	190	68 (2.4)

See the nameplate for electrical and refrigeration specifications. The nameplate is located inside the cabinet.

We reserve the right to make changes in specifications and design without prior notice.

B. Wiring Diagram

1. Sidemount Refrigerator and Freezer

a) LR46B(-D2)(-L), LR60B(-D2)(-D4), LR67B(-D2)(-D4)

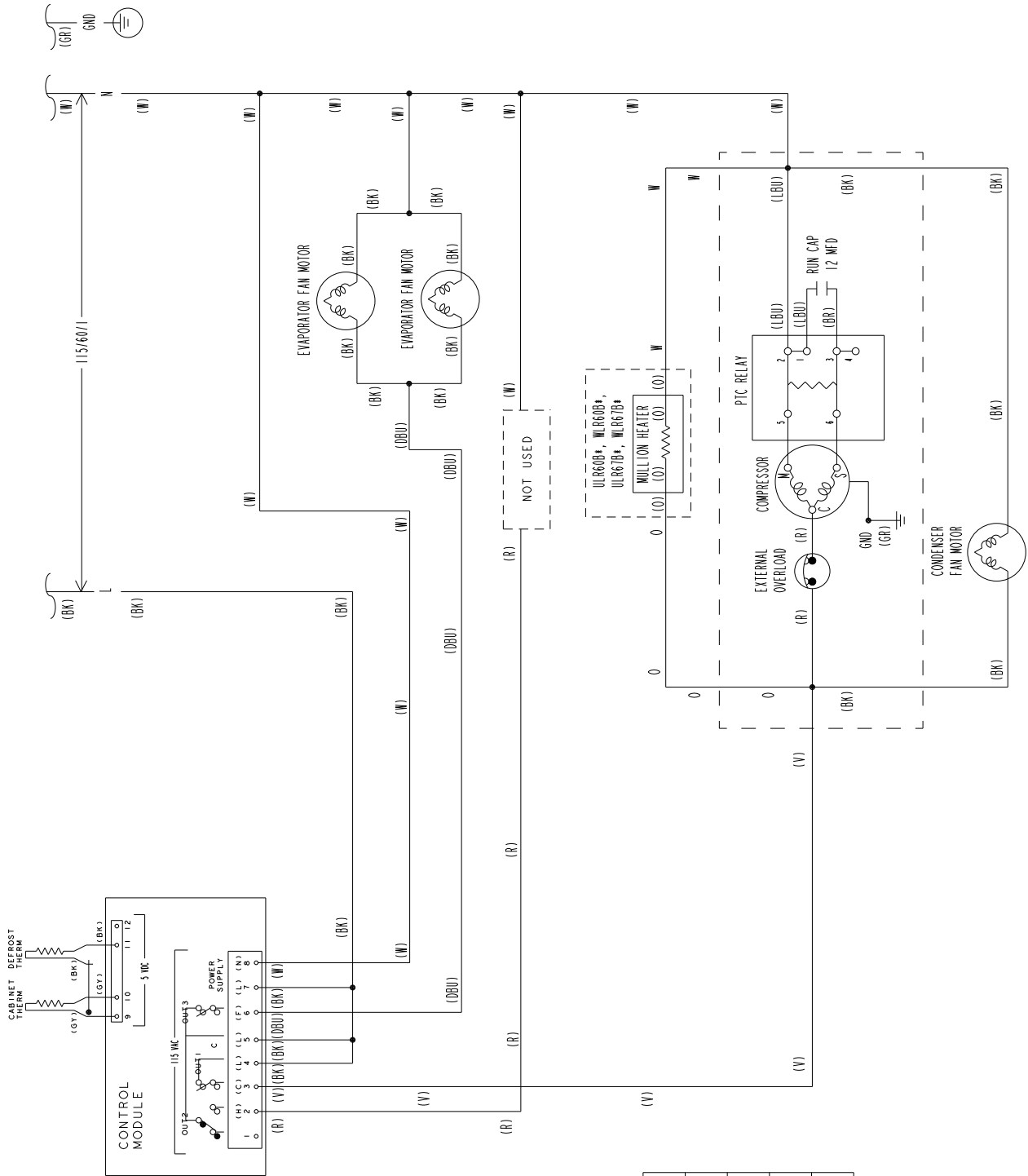

WIRE COLOR CODE	WIRE COLOR
BK	BLACK
BR	BROWN
DBU	DARK BLUE
GR	GREEN
GY	GRAY
LBU	LIGHT BLUE
O	ORANGE
P	PINK
R	RED
V	VIOLET
W	WHITE
Y	YELLOW

CTB = COMPRESSOR COVER TERMINAL BLOCK	TERMINAL
L1	NOT USED
L2	L LINE
N	NEUTRAL
⊕	GROUND

b) LR93B(-D2)(-D4)(-D6)

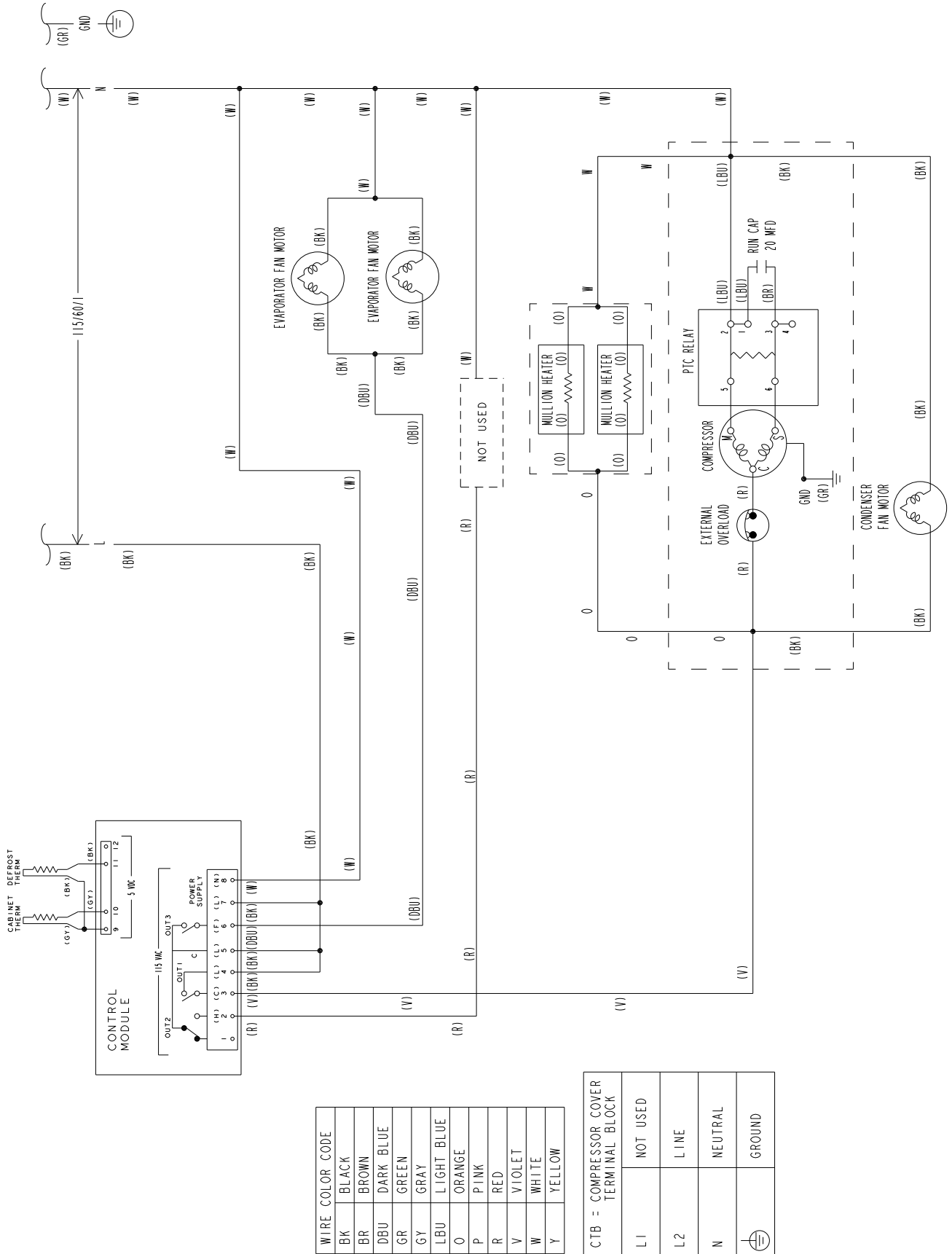

WIRE COLOR CODE	
BK	BLACK
BR	BROWN
DBU	DARK BLUE
GR	GREEN
GY	GRAY
LBU	LIGHT BLUE
O	ORANGE
P	PINK
R	RED
V	VIOLET
W	WHITE
Y	YELLOW

CTB = COMPRESSOR COVER TERMINAL BLOCK	
L1	NOT USED
L2	LINE
N	NEUTRAL
⊕	GROUND

c) LF46B, LF60B, LF67B

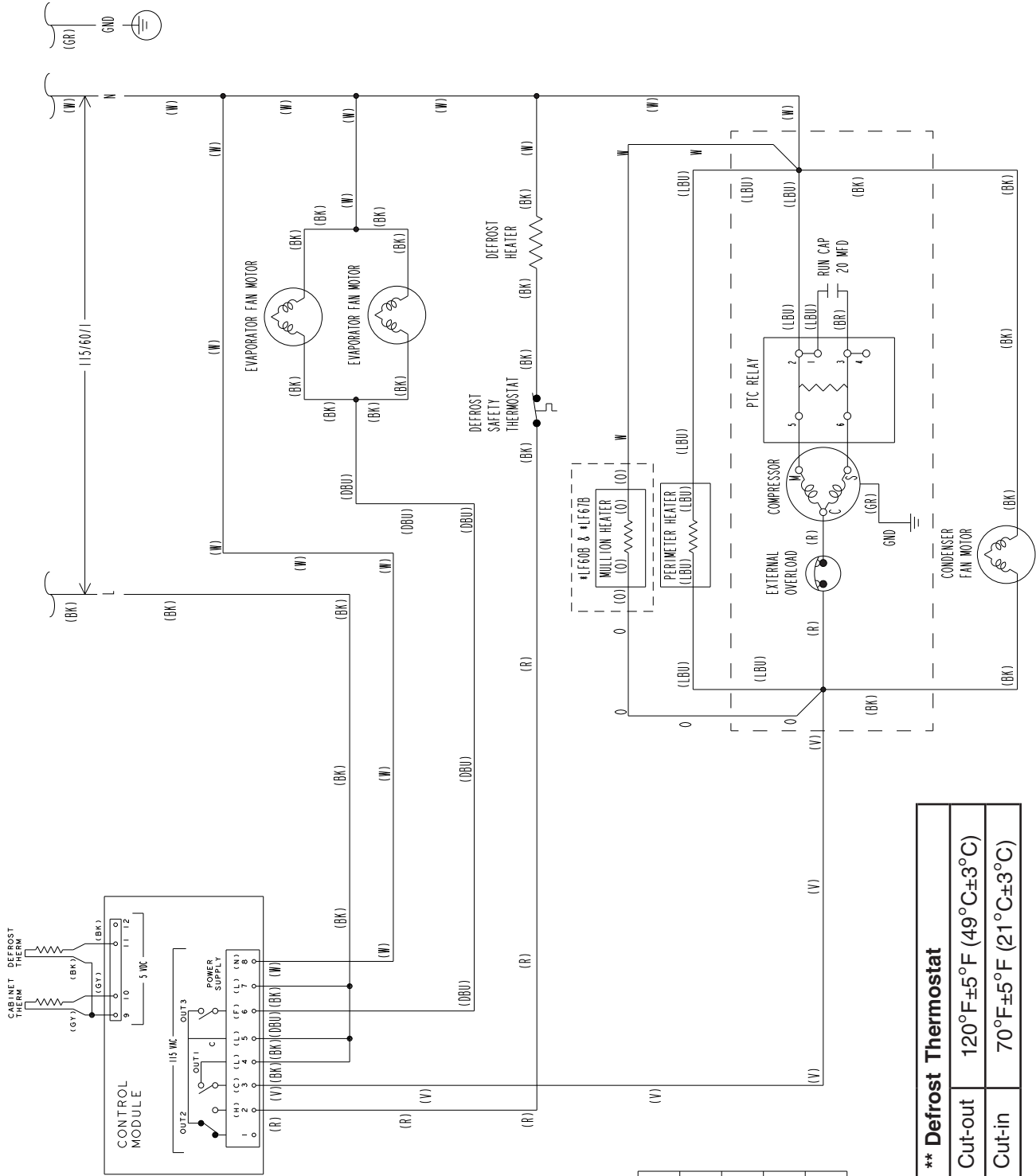

WIRE COLOR CODE	
BK	BLACK
BR	BROWN
DBU	DARK BLUE
GR	GREEN
GY	GRAY
LBU	LIGHT BLUE
O	ORANGE
P	PINK
R	RED
V	VIOLET
W	WHITE
Y	YELLOW

CTB = COMPRESSOR COVER TERMINAL BLOCK	
L1	NOT USED
L2	LINE
N	NEUTRAL
	GROUND

** Defrost Thermostat	
Cut-out	120°F±5°F (49°C±3°C)
Cut-in	70°F±5°F (21°C±3°C)

2. Equipment Stand Refrigerator and Freezer

a) CR_B(-L)

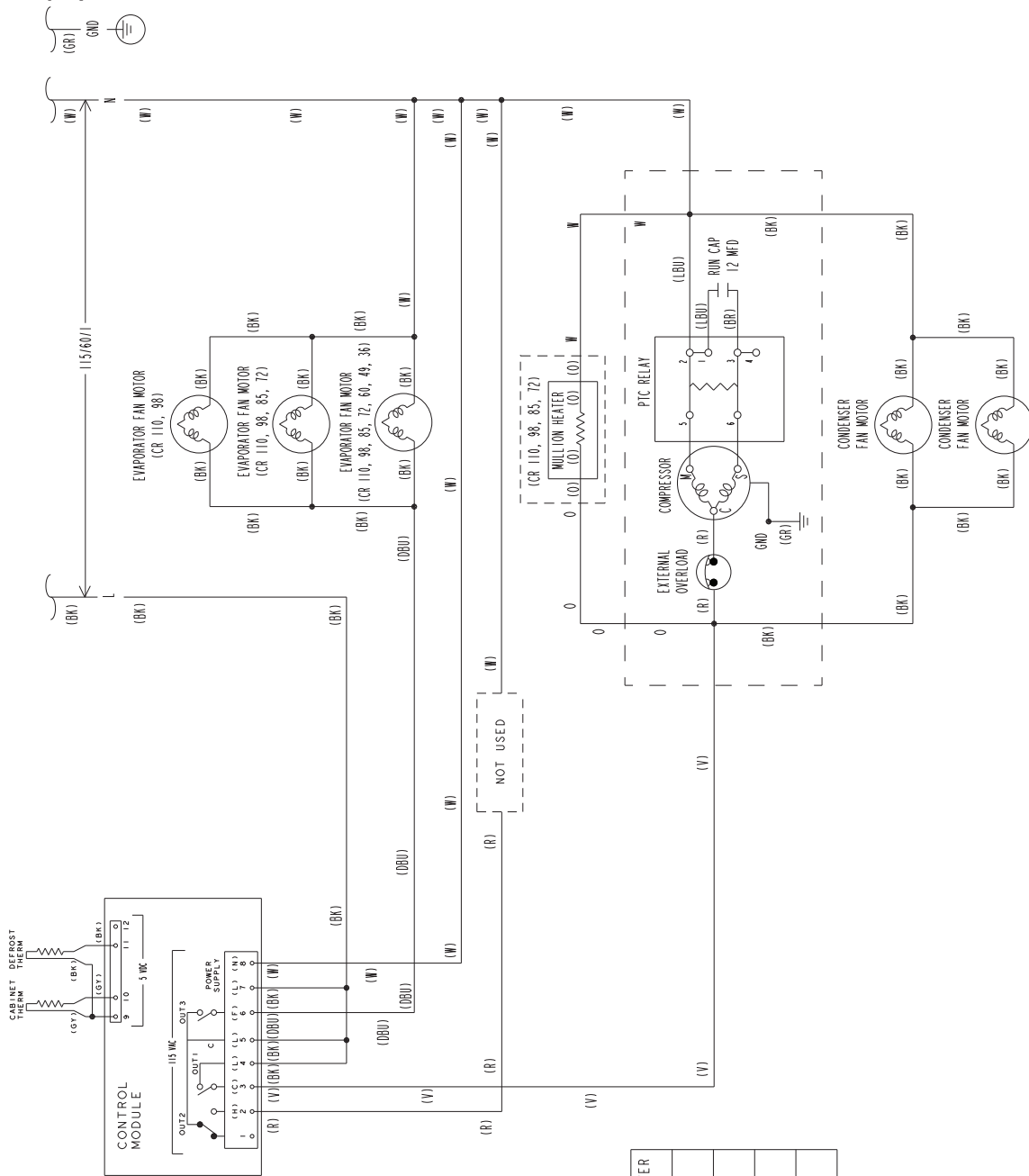

CTB = COMPRESSOR COVER TERMINAL BLOCK

L1	NOT USED
L2	LINE
N	NEUTRAL
	GROUND

WIRE COLOR CODE	
BK	BLACK
BR	BROWN
DBU	DARK BLUE
GR	GREEN
GY	GRAY
LBU	LIGHT BLUE
O	ORANGE
P	PINK
R	RED
V	VIOLET
W	WHITE
Y	YELLOW

b) CF_B(-L)

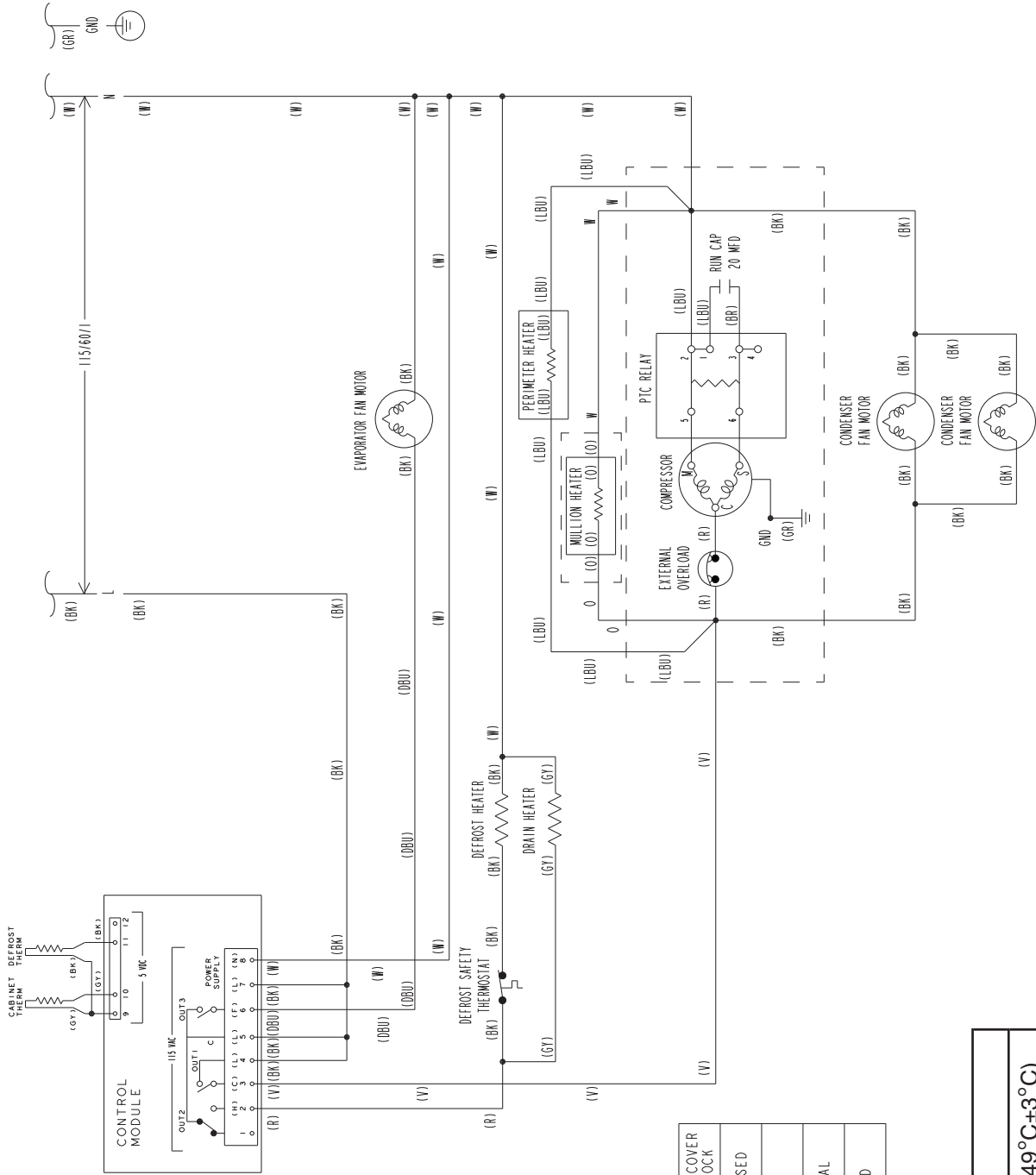

CTB = COMPRESSOR COVER TERMINAL BLOCK	
L1	NOT USED
L2	L LINE
N	NEUTRAL
	GROUND

WIRE COLOR CODE	
BK	BLACK
BR	BROWN
DBU	DARK BLUE
GR	GREEN
GY	GRAY
LBU	LIGHT BLUE
O	ORANGE
P	PINK
R	RED
V	VIOLET
W	WHITE
Y	YELLOW

** Defrost Thermostat	
Cut-out	120°F±5°F (49°C±3°C)
Cut-in	70°F±5°F (21°C±3°C)