



HOSHIZAKI

Service Manual

Cubelet Icemaker/Dispenser

Models

DCM-271BAH(-OS)



hoshizakiamerica.com

Number: 73242
Issued: 12-15-2020
Revised: 7-16-2021

⚠ WARNING

Only qualified service technicians should install and service the icemaker. To obtain the name and phone number of your local Hoshizaki Certified Service Representative, visit www.hoshizaki.com. No service should be undertaken until the technician has thoroughly read this Service Manual. Failure to service and maintain the appliance in accordance with this manual will adversely affect safety, performance, component life, and warranty coverage and may result in costly water damage. Proper installation is the responsibility of the installer. Product failure or property damage due to improper installation is not covered under warranty.

Hoshizaki provides this manual primarily to assist qualified service technicians in the service and maintenance of the appliance.

Should the reader have any questions or concerns which have not been satisfactorily addressed, please call, send an e-mail message, or write to the Hoshizaki Technical Support Department for assistance.

Phone: 1-800-233-1940; (770) 487-2331

Fax: 1-800-843-1056; (770) 487-3360

E-mail: techsupport@hoshizaki.com

HOSHIZAKI AMERICA, INC.

618 Highway 74 South

Peachtree City, GA 30269

Attn: Hoshizaki Technical Support Department

Web Site: www.hoshizaki.com

NOTE: To expedite assistance, all correspondence/communication **MUST** include the following information:

- Model Number _____
- Serial Number _____
- Complete and detailed explanation of the problem.

IMPORTANT

This manual should be read carefully before the appliance is serviced. Read the warnings and guidelines contained in this booklet carefully as they provide essential information for the continued safe use, service, and maintenance of the appliance. Retain this booklet for any further reference that may be necessary.

CONTENTS

Important Safety Information	4
I. Construction and Water Refrigeration Circuit Diagrams	6
A. Construction	6
B. Water/Refrigeration Circuit Diagrams	7
II. Sequence of Operation and Service Diagnosis	8
A. Sequence of Operation Flow Chart.....	8
B. Service Diagnosis	9
C. Control Board Check	15
D. Bin Control Check	23
E. Float Switch Check and Cleaning	24
F. Diagnostic Tables	26
III. Controls and Adjustments	30
A. Control Board Layout	31
a) Control Board.....	31
b) Upper/Lower Water and Ice Dispense Board.....	32
B. LED Lights and Audible Alarm Safeties.....	34
C. Settings and Adjustments.....	35
1. Default Dip Switch Settings	35
2. Bin Control Shutdown Delay (Infrared Sensor) (S1 dip switch 1, 2, 3)	35
3. Drain Frequency Control (S1 dip switch 4)	35
4. Continuous Dispensing Timer (S1 dip switch 5 & 6).....	36
5. Bin Control Selector (S1 dip switch 7)	36
6. Bin Control Shutdown Delay, Agitation, and Ice Purge Timer (S1 dip switch 8)	36
7. Bin Control Shutdown Delay (S1 dip switch 9)	37
8. Audible Alarm Silencer (S1 Dip Switch 10)	37
D. Switches	37
IV. Refrigeration Circuit and Component Service Information.....	38
A. Refrigeration Circuit Service Information	38
B. Component Service Information.....	41
C. Icemaking Unit	43
V. Maintenance	48
VI. Preparing the Appliance for Periods of Non-Use	49
VII. Disposal.....	50
VIII. Technical Information.....	51
A. Specification and Performance Data Sheets.....	51
1. DCM-271BAH	51
2. DCM-271BAH-OS	52
B. Wiring Diagram.....	53

Important Safety Information

Throughout this manual, notices appear to bring your attention to situations which could result in death, serious injury, damage to the appliance, or damage to property.

⚠ WARNING Indicates a hazardous situation which could result in death or serious injury.

NOTICE Indicates a situation which could result in damage to the appliance or property.

IMPORTANT Indicates important information about the use and care of the appliance.

⚠ WARNING

The appliance should be destined only to the use for which it has been expressly conceived. Any other use should be considered improper and therefore dangerous. The manufacturer cannot be held responsible for injury or damage resulting from improper, incorrect, and unreasonable use. Failure to service and maintain the appliance in accordance with this manual will adversely affect safety, performance, component life, and warranty coverage and may result in costly water damage.

To reduce the risk of death, electric shock, serious injury, or fire, follow basic precautions including the following:

- Only qualified service technicians should install and service the appliance.
- The appliance must be installed in accordance with applicable national, state, and local codes and regulations.
- The appliance requires an independent power supply of proper capacity. See the nameplate for electrical specifications. Failure to use an independent power supply of proper capacity can result in a tripped breaker, blown fuse, damage to existing wiring, or component failure. This could lead to heat generation or fire.
- **THE APPLIANCE MUST BE GROUNDED:** The appliance is equipped with a NEMA 5-15 three-prong grounding plug  to reduce the risk of potential shock hazards. It must be plugged into a properly grounded, independent 3-prong wall outlet. If the outlet is a 2-prong outlet, it is your personal responsibility to have a qualified electrician replace it with a properly grounded, independent 3-prong wall outlet. Do not remove the ground prong from the power cord and do not use an adapter plug. Failure to properly ground the appliance could result in death or serious injury.
- Do not use an extension cord.
- To reduce the risk of electric shock, do not touch the control switch or plug with damp hands. Make sure the control switch is in the "OFF" position before plugging in or unplugging the appliance.
- Do not use an appliance with a damaged power cord. The power cord should not be altered, jerked, bundled, weighed down, pinched, or tangled. Such actions could result in electric shock or fire. To unplug the appliance, be sure to pull the plug, not the cord, and do not jerk the cord.

⚠ WARNING, continued

- Do not make any alterations to the appliance. Alterations could result in electric shock, injury, fire, or damage to the appliance.
- Do not place fingers or any other objects into the ice discharge opening.
- The appliance is not intended for use by persons (including children) with reduced physical, sensory, or mental capabilities, or lack of experience and knowledge, unless they have been given supervision or instruction concerning use of the appliance by a person responsible for their safety.
- Young children should be properly supervised around the appliance.
- Do not climb, stand, or hang on the appliance or appliance door or allow children or animals to do so. Serious injury could occur or the appliance could be damaged.
- Do not use combustible spray or place volatile or flammable substances near the appliance. They might catch fire.
- Keep the area around the appliance clean. Dirt, dust, or insects in the appliance could cause harm to individuals or damage to the appliance.

NOTICE

- Follow the water supply, drain connection, and maintenance instructions carefully to reduce the risk of costly water damage.
- In areas where water damage is a concern, install in a contained area with a floor drain.
- Install the appliance in a location that stays above freezing. Normal operating ambient temperature must be within 45°F to 100°F (7°C to 38°C).
- Do not leave the appliance on during extended periods of non-use, extended absences, or in sub-freezing temperatures. To properly prepare the appliance for these occasions, follow the instructions in "VI. Preparing the Appliance for Periods of Non-Use."
- Do not place objects on top of the appliance.
- The storage bin is for ice use only. Do not store anything else in the storage bin.

I. Construction and Water Refrigeration Circuit Diagrams

A. Construction

1. DCM-271BAH(-OS)

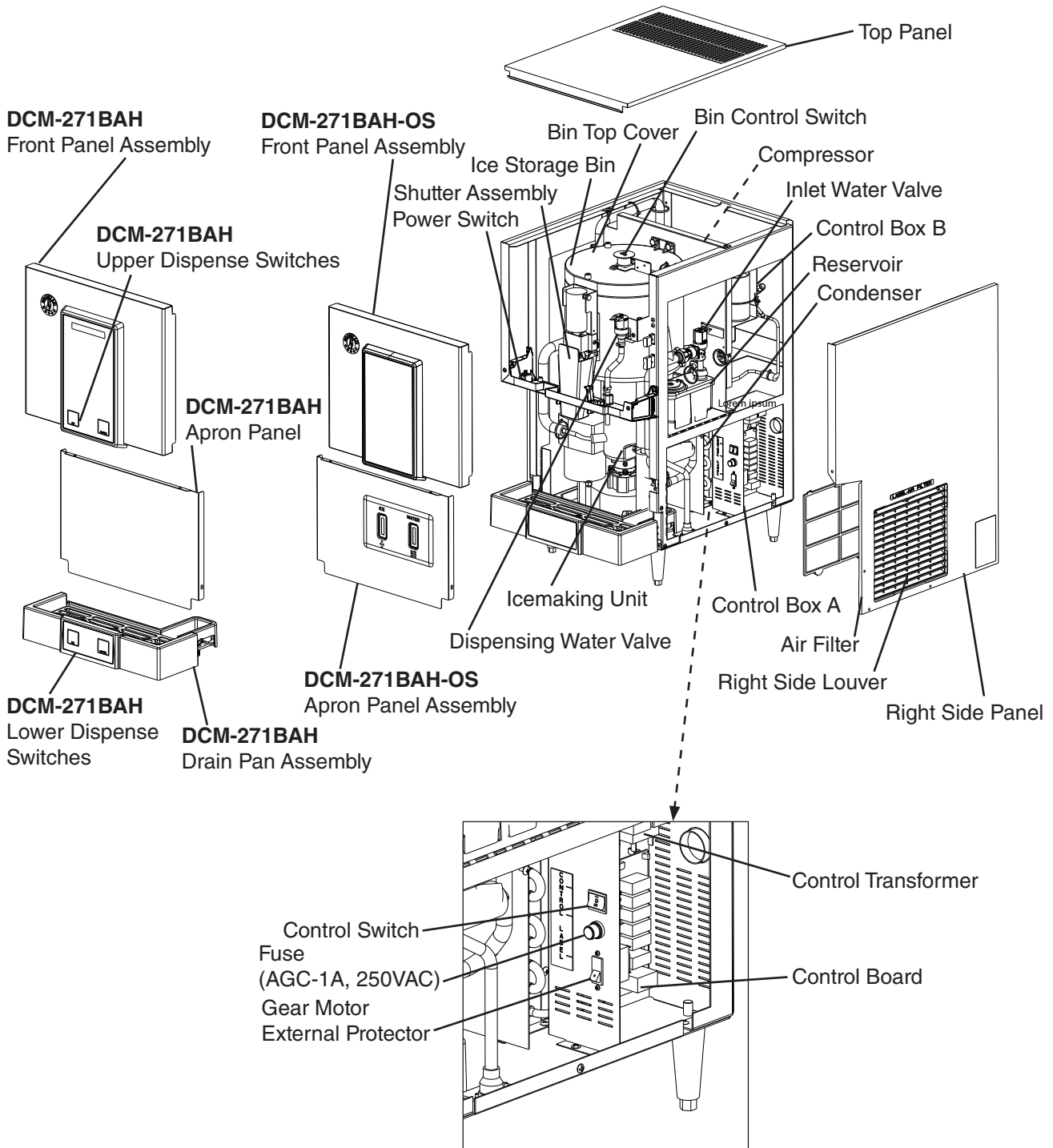

B. Water/Refrigeration Circuit Diagrams

DCM-271BAH(-OS)

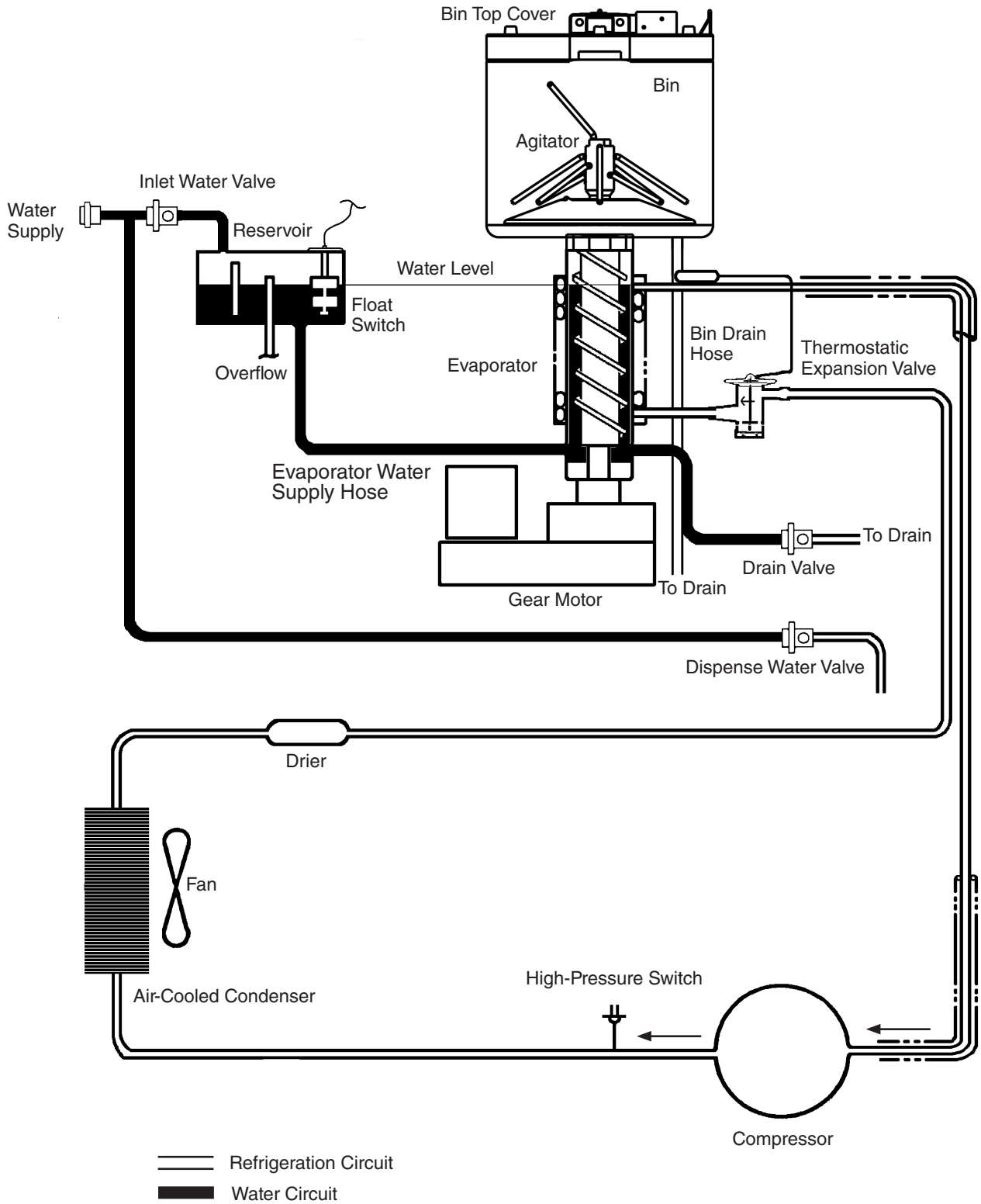

II. Sequence of Operation and Service Diagnosis

A. Sequence of Operation Flow Chart

Sequence Flow Chart DCM-271B_H(-OS)

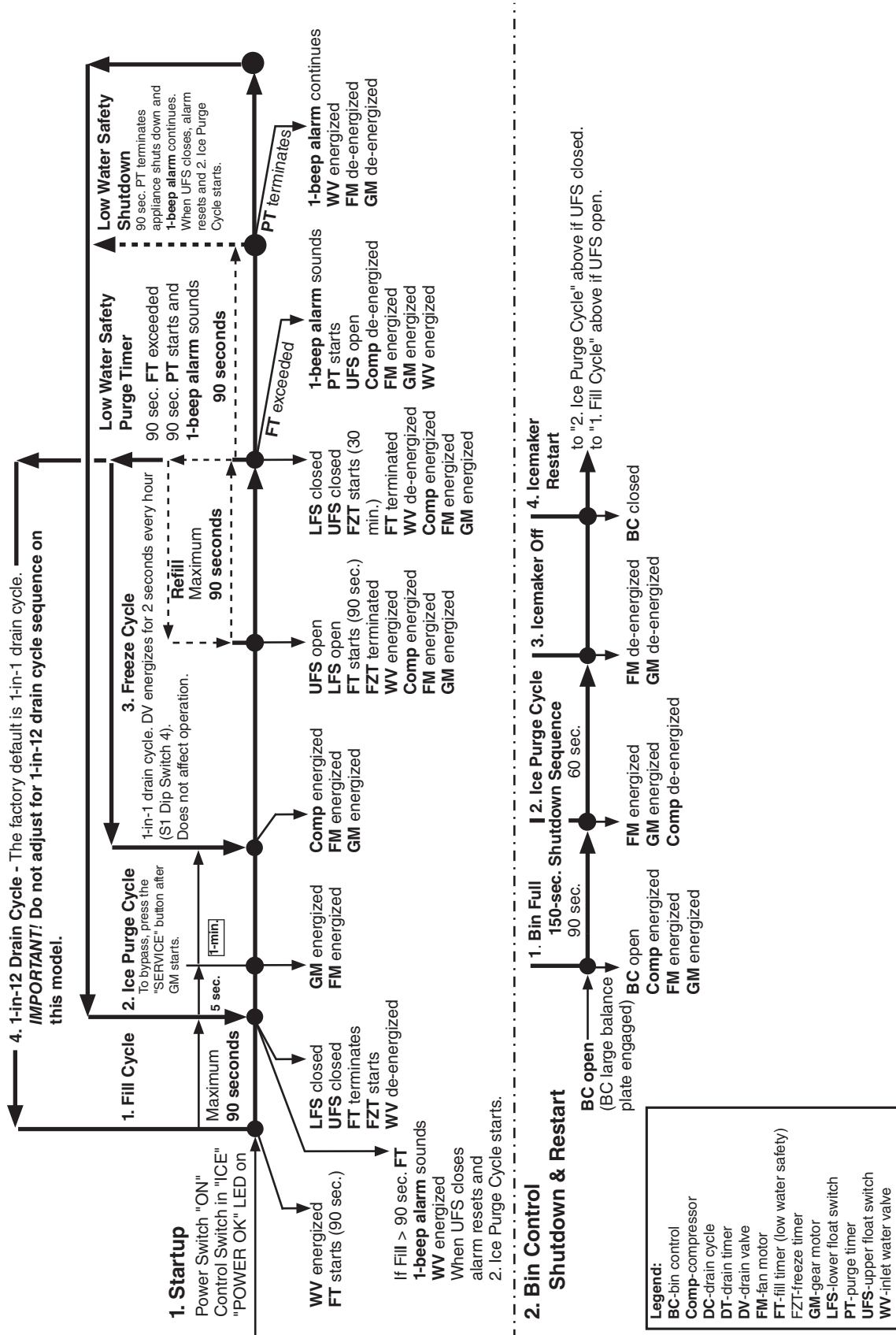

B. Service Diagnosis

WARNING

- The appliance should be diagnosed and repaired only by qualified service personnel to reduce the risk of death, electric shock, serious injury, or fire.
- Risk of electric shock. Use extreme caution and exercise safe electrical practices.
- Moving parts (e.g., fan blade) can crush and cut. Keep hands clear.
- **CHOKING HAZARD:** Ensure all components, fasteners, and thumbscrews are securely in place after the appliance is serviced. Make sure that none have fallen into the storage bin.
- Make sure all food zones in the appliance are clean after service. For cleaning procedures, see the instruction manual or the maintenance label.

1. Ice Production Check

To check ice production, remove the front, top, and left side panels. Place a container under the spout and dispense all ice from the icemaker. Note: The ice dispense switch times out after 20 sec. Re-engage every 20 sec. until bin is empty. Move the control switch and power switch to the "OFF" position. Remove the bin top cover. Pour warm water over the remaining ice. After the ice is removed/melted, place the bin top cover in its original position. Do not secure at this time. Remove the control box cover, then move the control switch to the "ICE" position and the power switch to the "ON" position. Once the gear motor starts, press the "SERVICE" button on the control board (located in the control box). **WARNING! Risk of electric shock. Care should be taken not to touch live terminals.** Lift the bin top cover and monitor the evaporator extruding head. **WARNING! Keep hands, hair, and loose clothing clear of the agitator rotating inside of the ice storage bin.** Once ice begins to fill the bin, start a 10 min. timer. After 10 min., move the power switch to the "OFF" position. Place an empty container under the spout and dispense all ice from the icemaker. Note: The ice dispense switch times out after 20 sec. Re-engage every 20 sec. until bin is empty. Move the power switch to the "OFF" position. Weigh the ice to establish the batch weight (minus the weight of the container). Multiply the batch weight by 144 for the total production in 24 hr. Replace the control box cover and bin top cover in their correct positions and secure. Replace all panels in their correct positions and secure. Move the power switch to the "ON" position to start the automatic icemaking process.

2. Diagnostic Procedure

The diagnostic procedure is a sequence check that allows you to diagnose the electrical system and components. Before proceeding, check for correct installation, adequate water pressure (10 to 113 PSIG), and proper voltage per unit nameplate.

Note: • When checking high voltage (115VAC), always choose a neutral (W) wire to establish a good neutral connection.

- When checking low voltage (24VAC), always choose a neutral (LBU) wire.
- When checking control board DC voltage (5VDC), always place the red test lead from the multimeter to CB red K4 pin #1 (pin closest to CB black K3 connector). See "II.C. Control Board Check."
- To speed up the diagnostic process, the ice purge cycle may be bypassed by pressing the "SERVICE" button on the control board after the gear motor starts. **WARNING! Risk of electric shock. Care should be taken not to touch live terminals.**
- If the icemaker is in alarm, see "III.B. LED Lights and Audible Alarm Safeties."
- CB monitors the following switches with 5VDC during the icemaking process: Control Switch (CS), High-Pressure Switch (HPS), Float Switch (FS), Compressor Control Relay (CCR), and Bin Control (BC).
When 5VDC is present across any of these switches, the switch is open.

- 1) Move the power switch to the "OFF" position, then unplug the power cord from the electrical outlet. Remove the front, top, and left side panels.
- 2) Plug the power cord back into the electrical outlet, then move the power switch to the "ON" position.
- 3) Move the control switch to the "DRAIN" position. CB "POWER OK" LED and "FLUSH" (drain) LED turns on.

Diagnosis "POWER OK" LED: Check that CB "POWER OK" LED is on. If not, check for 115VAC at control transformer brown (BR) wire to neutral (W). If 115VAC is not present, check the power switch, power cord connection, and breaker. If 115VAC is present, check control transformer continuity. Replace as needed. Next, check for 24VAC at control transformer red (R) wire to neutral (LBU). If 24VAC is not present, check control transformer continuity. Replace as needed. If 24VAC is present, check 24VAC 1A fuse. If fuse is good, check for 24VAC at CB K8 #1 (W/R) to CB K8 #2 (LBU). If 24VAC is present and "POWER OK" LED is off, replace CB.

Diagnosis DV: If DV does not energize, check for 24VAC at CB K2 #10 (W/DBU) to neutral (LBU). If 24VAC is not present, check control switch continuity. If open while in the "DRAIN" position, replace control switch. If closed, check for 5VDC at CB red K4 pin #1 (pin closest to CB black K3) to K9 #1 (W/BK) and to K9 #2 (W/BK). If 5VDC is present between CB red K4 pin #1 (pin closest to CB black K3) and K9 #1 and not at K9 #2 and control switch is closed, replace CB. If 24VAC is present, check for restricted DV and DV solenoid continuity. Clean or replace as needed.

- 4) Allow the water system to drain completely. Move control switch to the "ICE" position.

5) **Startup–CB "POWER OK" LED is on.** Turn on the power supply, then move the power switch to the "ON" position. CB "POWER OK" LED and IS green LED turn on.

Diagnosis CB "POWER OK" LED: Check that CB "POWER OK" LED is on. If not, check for 115VAC at control transformer black (BK) wire to neutral (W). If 115VAC is not present, check the power switch, power cord connection, and breaker. If 115VAC is present, check control transformer continuity. Replace as needed. Next, check for 24VAC at control transformer red (R) wire to neutral (LBU). If 24VAC is not present, check control transformer continuity. Replace as needed. If 24VAC is present, check 24VAC 1A fuse. If fuse is good, check for 24VAC at CB K8 #1 (W/R) to CB K8 #2 (LBU). If 24VAC is not present, check control switch continuity. If open while in the "ICE" position, replace control switch. If 24VAC is present and "POWER OK" LED is off, replace CB.

6) **Fill Cycle – "WTRIN" LED is on.** Reservoir is empty and LFS and UFS are open. 90-sec. FT starts. WV energizes and fill cycle starts. LFS closes. Nothing occurs at this time. Reservoir continues to fill until UFS closes. When UFS closes, WV de-energizes, 90-sec. FT is terminated, CB "WTRIN" LED turns off, 30-min. FZT and 5-sec. GM delay timer start. If UFS remains open longer than 90 sec. after LFS opens, FT exceeded and CB sounds a 1-beep alarm. WV remains energized until UFS closes. Alarm resets automatically when UFS closes. **Diagnosis:** If reservoir is empty and "WTRIN" LED is off, confirm LFS status. See "II.E.1. Float Switch Check." If LFS is open and "WTRIN" LED is off, replace CB. If "WTRIN" LED is on, check that the reservoir fills. If not, check water supply line shut-off valve, water filters, and WV screen. If "WTRIN" LED is on and WV is off, check CB K2 #8 (O) to a neutral (LBU) for 24VAC. If 24VAC is not present, check CB K2 #9 (W/R) to a neutral (LBU) for 24VAC. If 24VAC is present on CB K2 #9 (W/R) and not on CB K2 #8 (O), replace CB. If 24VAC is present on CB K2 #8 (O), check continuity through WV solenoid. If open, replace WV. If WV is energized and refill exceeds FT with no water in the reservoir, check for DV leaking. If reservoir is full and overflowing check for open UFS. See "II.E.1. Float Switch Check." If UFS is closed, check that WV de-energizes. If not, check CB K2 #8 (O) to a neutral (LBU) for 24VAC. If 24VAC is present, replace CB. If WV de-energizes and water continues to fill the reservoir, replace WV.

Note: **Low Water Safety**– If UFS remains open 90 sec. after WV energizes, a 1-beep alarm sounds. This alarm resets automatically once UFS closes.

7) **Ice Purge Cycle – "GM" LED is on.** 5-sec. GM delay timer terminates. GM, FM, and CCR energize. Once CCR energizes, 5VDC circuit closes through CCR terminal #3 (W/O) and terminal #5 (W/O) and CB K9 #5 (W/O) and K9 #6 (W/O). After 5VDC circuit closes, 5-min. ice purge timer starts. To bypass the 5-min. Ice Purge Cycle, press the "SERVICE" button on CB after the "GM" LED turns on. **WARNING! Risk of electric shock. Care should be taken not to touch live terminals.** CCR cannot energize unless GM circuit is complete (GM external protector and GM internal protector). See "II.C.2)(1)c) Compressor Control Relay (Ice Purge Timer Circuit)."
If CCR de-energizes, CB K9 #5 W/O and CB K9 #6 W/O circuit opens and an 8-beep alarm occurs. See "III.B. LED Lights and Alarm Safeties." Note: To bypass ice purge cycle and go straight to freeze cycle, press the "SERVICE" button on CB after GM energizes.

Diagnosis CB: If "GM" LED is off, check that UFS closes and WV de-energizes. If UFS is closed, 30 sec. has passed, and "GM" LED remains off, replace CB. If "GM" LED is on and GM is off, check CB K1 #2 (BK) to a neutral (W) for 115VAC. If 115VAC is not present, check 115VAC power supply. If 115VAC is present, check CB K1 #3 (P) to neutral (W). If 115VAC is present on CB K1 #2 (BK) and not on CB K1 #3 (P), replace CB.

Diagnosis GM: If 115VAC is present at CB K1 #3 (P) to neutral (W), check GM external protector. If tripped, reset. If GM external protector is closed, check GM internal protector (windings). If open, allow time for GM to cool down and internal protector to reset. If not, replace GM. Next, check GM capacitor and GM coupling between auger and GM.

Diagnosis FM: If FM does not start, check that fan blades are not binding. Next, check FM capacitor, FM windings, and FM bearing.

Diagnosis CCR: See "II.C.2)(1)c) Compressor Control Relay (Ice Purge Timer Circuit)."
Once 5-min. ice purge timer terminates or the "SERVICE" button is pressed, freeze cycle begins.

8) **Freeze Cycle – "COMP" and "GM" LEDs are on.** The 5-min. ice purge timer terminates or the "SERVICE" button is pressed. "COMP" LED turns on. "GM" LED continues. Comp energizes. GM, FM, and CCR continue. Ice production begins 4 to 6 minutes after Comp energizes depending on ambient and water conditions. As ice is produced, the water level in the reservoir drops. UFS opens. Nothing happens at this time. When LFS opens, WV energizes and refill cycle begins, FZT terminates, and FT starts.

FZT: 30-Min. Freeze Safety Timer: FZT starts when UFS closes and terminates when LFS opens. If LFS does not open within 30 min. of UFS closing, CB shuts down the icemaker and sounds a 5-beep alarm. See "III.B. LED Lights and Audible Alarm Safeties." To reset, turn the power supply off and on again. See "II.F.Diagnostic Tables" for troubleshooting details.

Icemaker Diagnosis (CCR): 5-min. ice purge timer terminates, CB "COMP" LED turns on and COMP energizes. If not, check for 5VDC between CB K4 connector pin closest to CB K3 connector and CB K9 connector #5 (W/O). If 5VDC is not present, replace CB. If 5VDC is present, check for 5VDC between CB K4 connector pin closest to CB K3 connector and CB K9 connector #6 (W/O). If 5VDC is present and CB "Comp" LED is off, COMP not energized, replace CB. If 5VDC is not present, check for 115VAC between CCR terminal #7 (R) to CCR terminal #8 (W) for 115VAC. If 115VAC is not present, GM not energized, see step 7 above. If 115VAC is present and CCR contacts are open (5VDC present between terminals #3 (W/O) and #5 (W/O)), check CCR solenoid continuity. If open, replace CCR.

Note: If CCR de-energizes, CB K9 #5 W/O and CB K9 #6 W/O circuit opens, Comp de-energizes and an 8-beep alarm occurs. See "III.B. LED Lights and Alarm Safeties."

Diagnosis COMP: If "COMP" LED is on and COMP is not energized, check CB X1 relay BK wire to a neutral (W) and CB X1 relay R wire to a neutral (W) for 115VAC. If 115VAC is present on CB X1 BK wire and not on CB X1 R wire, replace CB. If 115VAC is present on CB X1 R wire and COMP is not energized, check Comp windings (internal protector), start relay, and capacitor.

- 9) **Refill Cycle/Low Water Safety** – As ice is produced, the water level in the reservoir drops. UFS opens. Nothing occurs at this time. When LFS opens, WV energizes, 90-sec. low water safety timer (fill timer) starts. Comp, GM, CCR, and FM continue. When UFS closes, WV de-energizes, 90-sec. low water safety timer (fill timer) terminates and 30-min. freeze timer resets. If UFS remains open 90 sec. after WV energizes (fill timer exceeded), a 90-sec. shutdown cycle starts. Comp de-energizes and CB signals a 1-beep alarm every 5 sec. 90-sec. ice purge timer starts. FM, GM, and CCR continue to clear ice from the evaporator. 90-sec. ice purge timer terminates, FM, GM and CCR de-energize. WV and 1-beep alarm continue until UFS closes.

Diagnosis – Check that "WTRIN" LED is on. If not, check LFS. See "II.E. Float Switch Check and Cleaning." If LFS is open and "WTRIN" LED is off, replace CB. If "WTRIN" LED is on, check that the reservoir fills. If not, check the water supply line, restricted water filters, WV solenoid, restricted WV screen. If WV is energized and refill exceeds 90-sec. low water safety timer (fill timer), check DV leaking by or open UFS. See "II.E. Float Switch Check and Cleaning."

Note: Each time UFS closes, 30-min. freeze timer starts. The 30-min. freeze timer resets when UFS closes again. If UFS does not close again within 30 min., CB shuts down the icemaker and sounds a 5-beep alarm every 5 sec. See "II.B. LED Lights and Alarm Safeties."

10) Drain Cycle

- a) **1-n-1 Drain Cycle:** DV energizes once every hour when the 1-in-1 drain cycle is activated (S1 dip switch 4 in the "OFF" position (factory default position)). GM, FM, and Comp continue. DV energizes for 2 sec. every hour. This setting is recommended for optimum icemaker performance. The 1-in-1 drain cycle allows any sediment to drain from the evaporator without interrupting the icemaking process.
- b) **1-in-12 Drain Cycle (optional):** DV energizes once every 12 hours when the 1-in-12 drain cycle is activated (S1 dip switch 4 in the on position (optional)). 12-hour drain cycle timer terminates, Comp de-energizes. GM and FM continue. The 5-min. ice purge timer starts. When the 5-min. ice purge timer terminates, GM and FM de-energize. 10-min. DT starts, DV energizes. After 10-min. DT terminates, DV de-energizes icemaking process restarts and 12-hour drain cycle timer starts.
- c) **Manual Drain:** Manual drain is used when servicing evaporator components and cleaning and sanitizing the unit. When the unit is making ice and the control switch is moved to the "DRAIN" position, there is a 3-sec. delay, then Comp de-energizes and the 5-min. ice purge timer begins. When the 5-min. ice purge timer terminates, GM and FM de-energize. DV energizes to drain the evaporator and reservoir. To avoid the 5-min. shutdown delay, turn off the power supply, then move the control switch to the "DRAIN" position. Turn on the power supply. DV energizes to drain the evaporator and reservoir. DV de-energizes when the control switch is moved to the "ICE" position.

Diagnosis DV: If DV does not energize, check for 24VAC at CB K2 #10 (W/DBU) to neutral (LBU). If 24VAC is not present, check control switch continuity. If open while in the "DRAIN" position, replace control switch. If closed, check for 0VDC at control board K9 #1 (W/BK) to K9 #2 (W/BK). If 5VDC is present and control switch is closed, replace CB. If 24VAC is present, check for restricted DV and DV solenoid continuity. Clean or replace as needed.

11) Shutdown

Bin fills with ice activating BC. CB starts 90-sec. Comp shutdown timer. Once 90-sec. Comp shutdown timer terminates, Comp de-energizes and 60-sec. GM shutdown timer starts. Once 60-sec. GM shutdown timer terminates, FM and GM de-energize and icemaker is off.

Shutdown Diagnosis: Check that BC large balance plate is activated and not sticking. Check BC micro-switch continuity. When BC large balance plate is down (icemaking), BC micro-switch is closed. When BC large balance plate is up BC micro-switch is open. If not, replace BC micro-switch. If BC micro-switch is open and Comp, FM, and GM do not de-energize, replace CB. See "II.C. Control Board Check."

Legend: **BC**—bin control; **CB**—control board; **CCR**—compressor control relay;
Comp—compressor; **CT**—control transformer; **DV**—drain valve; **FM**—fan motor;
GM—gear motor; **LFS**—lower float switch; **UFS**—upper float switch; **WV**—inlet water valve

C. Control Board Check

Before replacing a CB that does not show a visible defect and that you suspect is bad, always conduct the following check procedure. This procedure will help you verify your diagnosis. Before proceeding, check for proper voltage per appliance nameplate. Check that the 24VAC 1A fuse is good and 115VAC 3A GM external protector is closed.

- Check the S1 dip switch settings to assure that they are in the factory default position. For factory default settings, see "III.C.1. Default Dip Switch Settings." S1 dip switch 7 determines bin control application. **WARNING! Do not adjust S1 dip switch 4, 7, 8, or 9 dip switches out of their factory default positions. These dip switches must be left in the factory default position or the appliance will not operate correctly.**
 - When checking for 115VAC high-voltage (primary), always choose a 115VAC neutral (W) to establish a good neutral connection.
 - When checking for 24VAC low-voltage (secondary), always choose a 24VAC neutral (LBU) to establish a good neutral connection. If the appliance is in alarm, see "III.B. LED Lights and Audible Alarm Safeties."
 - When checking for 5VDC, use CB red K4 connector pin closest to CB black K3 connector to complete DC circuit.
- 1) **Startup-"POWER OK" LED on:** Move control switch to "ICE" position, then move power switch to "ON" position. "POWER OK" LED turns on. "POWER" LED remains on unless power supply is interrupted. **Diagnosis:** Check that "POWER OK" LED is on. If not, check for proper 115VAC supply voltage to CT (main breaker or fuse, power supply cord, and power switch). Next, check for proper 24VAC output from CT. Next, check that 1A fuse is good. Check for 24VAC from CB K8 connector pin #1 (W/R) to CB K8 connector pin #2 (LBU). If 24VAC is not present, check control switch continuity. If open while in the "ICE" position, replace control switch. If 24VAC is present and "POWER OK" LED is off, replace CB.
 - 2) **5VDC Output Checks:** There are seven 5VDC circuits on the appliance.
 - a) 3 circuits at CB K9 connector: Control switch, high-pressure switch (HPS), and compressor control relay (CCR).
 - b) 2 circuits at CB K8 connector: Bin control (BC) and float switch (FS upper and lower).
 - c) 2 circuits at CB K7 connector: Ice dispense (push button, and OS sensor), and water dispense (push button and OS sensor).
- (1) **5VDC CB K9 Connector:** See Fig. 1.
- a) **Control Switch "DRAIN" Position**
CB K9 connector pins #1 (W/BK) and #2 (W/BK):
 - "ICE" Position: When the control switch is in the "ICE" position, CB K9 connector pin #1 and pin #2 are open. 5VDC is present between CB K9 connector pin #1 (W/BK) and pin #2 (W/BK). If not, check control switch position and continuity (open). Replace as needed. Next, confirm 5VDC between pin #1 (W/BK) and CB red K4 connector, pin closest to CB black K3 connector. If 5VDC is not present, replace CB.

- "DRAIN" Position: When control switch is in the "DRAIN" position, CB K9 connector pin #1 (W/BK) and pin #2 (W/BK) are closed. 0VDC is present between pin #1 (W/BK) and pin #2 (W/BK). If not, check control switch position and continuity. Next, confirm 5VDC is present between both CB K9 connector pin #1 (W/BK) and pin #2 to CB red K4 connector, pin closest to CB black K3 connector. If 5VDC is not present on both pins, replace CB.

b) High-Pressure Switch (HPS)

CB K9 connector pins #3 (Y) and #4 (Y): When HPS is closed, 5VDC is present between both CB K9 connector pins #3 (Y) and pin #4 (Y) to CB red K4 connector pin closest to CB black K3 connector. If 5VDC is not present on pin #3 (Y) or pin #4 (Y), replace CB. If 5VDC is present on CB K9 connector pin #3 (Y) and not on CB K9 connector pin #4 (Y), HPS is most likely open. CB sounds a 3-beep alarm. Check HPS continuity. If HPS is open and CB is not in alarm, replace CB.

c) Compressor Control Relay (CCR)

CB K9 connector pins #5 (W/O) and #6 (W/O): When CCR is de-energized (GM off), CCR terminals #3 and #5 are open and 5VDC is present between CB K9 connector pin #5 (W/O) and CB K9 connector pin #6 (W/O). If 5VDC is not present, check CCR continuity between terminals #3 and #5. If closed and CCR is de-energized, replace CCR. Check for 5VDC at CB K9 pin #5 (W/O) and CB red K4 pin #1 (pin closest to CB black K3). If 5VDC is not present, replace CB. When CCR is energized, CCR terminals #3 and #5 close and 0VDC is present between CB K9 pin #5 (W/O) and pin #6 (W/O). 5VDC is present between CB K9 pin #5 (W/O) to CB red K4 pin #1 (pin closest to CB black K3) and CB K9 pin #6 (W/O) to CB red K4 pin #1 (pin closest to CB black K3). If GM is energized and CCR terminals #3 & #5 are open, an 8-beep alarm occurs. See "III.B. LED Lights and Audible Alarm Safeties." If CCR terminals #3 and #5 are closed, Comp delay timer starts. If Comp does not energize after Comp delay timer terminates, replace CB.

5VDC CB K9 Connector	
Component	Pin # (Wire Color)
Control Switch "DRAIN" Position	#1 (W/BK) and #2 (W/BK)
High-Pressure Switch (HPS)	#3 (Y) and #4 (Y)
Compressor Control Relay (CCR) (CCR relay terminals #3 W/O and #5 W/O)	#5 (W/O) and #6 (W/O)

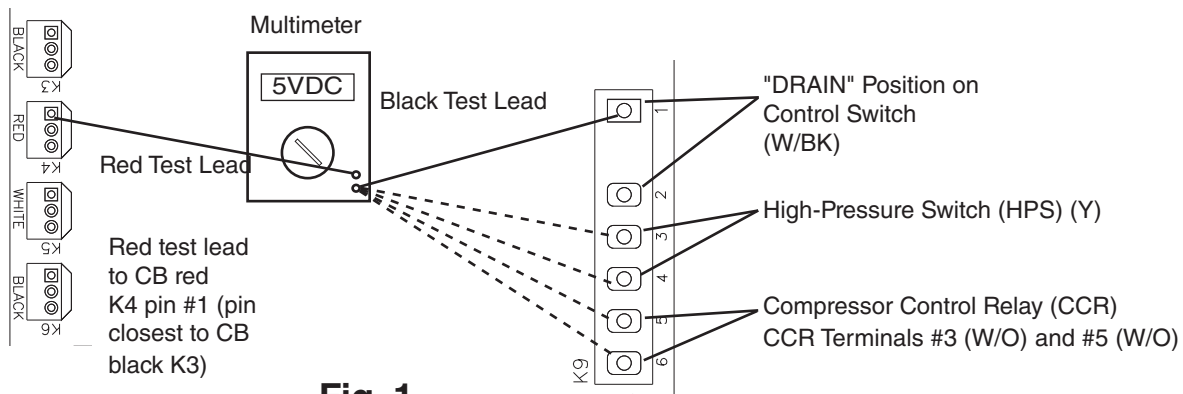

Fig. 1
Control Board K9 Connector

(2) **5VDC CB K8 Connector:** See Fig. 2.

a) **Bin Control (BC)**

CB K8 pin #3 (GY) and pin #4 (GY): When BC is closed (icemaking), 5VDC is present between CB K8 pin #3 (GY) and pin #4 (GY) to CB red K4 pin #1 (pin closest to CB black K3). If 5VDC is not present on either pin, replace CB. If 5VDC is present on pin #3 (GY) and not on pin #4 (GY), BC is open. See "II.D. Bin Control Check."

b) **Float Switch (FS): Upper (UFS) and Lower (LFS):**

CB K8 pin #5 common (BK), pin #6 UFS (R), and pin #7 LFS (BU): 5VDC is present between CB K8 pin #5 common (BK) and CB red K4 pin #1 (pin closest to CB black K3) at all times. If 5VDC is not present, replace CB. For further float switch diagnostics, see "II.E. Float Switch Check and Cleaning."

5VDC CB K8 Connector	
Component	Pin # (Wire Color)
Bin Control (BC)	#3 (GY) and #4 (GY)
Float Switch (FS) Common	#5 (BK) Common
Upper Float Switch (UFS)	#6 (R)
Lower Float Switch (LFS)	#7 (BU)

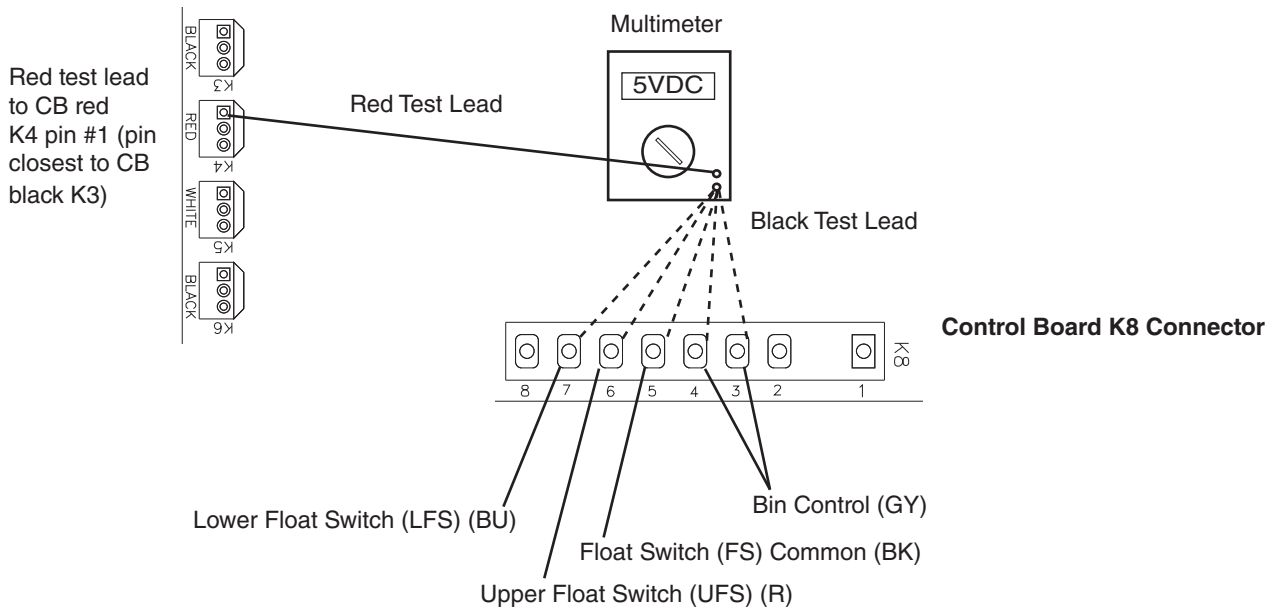

Fig. 2

(3) **5VDC CB K7 Connector:** See Figs. 3, 4, 5, and 6.

a) **Water Dispense**

1. **Push Button Model**

CB K7 pin #3 (W/BK) and pin #8 (P): "WTRDP" LED is on: Before engaging the water dispense switch, check for the correct VDC from the locations given in the "Disengaged" column in the table below. If the VDC is different than in the table, replace CB. If the VDC is correct, engage the water dispense switch. "WTRDP" LED turns on. If not, confirm that the water dispense signal VDC matches the "Engaged" column in the table below. If not, check the water dispense switch continuity when engaged (closed). If the water dispense switch is open when engaged, replace the water dispense switch. If the VDC matches the "Engaged" column below and the "WTRDP" LED does not turn on, replace CB.

5VDC CB K7 Connector					
Component	Pin # (Wire Color)	To	CB VDC Ground	Disengaged	Engaged
5VDC Power Supply	#3 (W/BK)	To	Red K4 pin #1 (closest to CB black K3)	5VDC	5VDC
Water Dispense Signal	#8 (P)			0VDC	5VDC

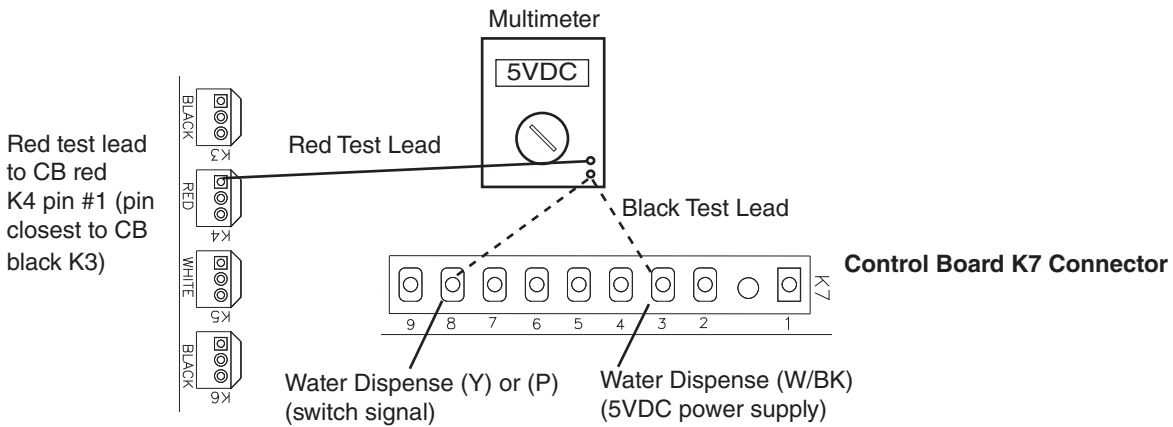

Fig. 3

2. Opti-Serve Model

CB K8 connector pins #7 (R), #8 (P), and #9 (BK): Before engaging the water dispense OS sensor, check for the correct VDC from the locations given in the "Disengaged" column in the table below. If the VDC is different than in the table, replace CB. If the VDC is correct, engage the OS sensor. "WTRDP" LED turns on. If not, confirm that the water dispense signal VDC matches the "Engaged" column in the table below. If not, replace the OS sensor. If the VDC matches the "Engaged" column below and the "WTRDP" LED does not turn on, replace CB.

5VDC CB K7 Connector					
Component	Pin # (Wire Color)	To	CB VDC Ground	Disengaged	Engaged
VDC Sensor Ground	#7 (R)	To	Red K4 pin #1 (closest to CB black K3)	0VDC	0VDC
Water Dispense Signal	#8 (P)			0VDC	5VDC
5VDC Power Supply	#9 (BK)			5VDC	5VDC

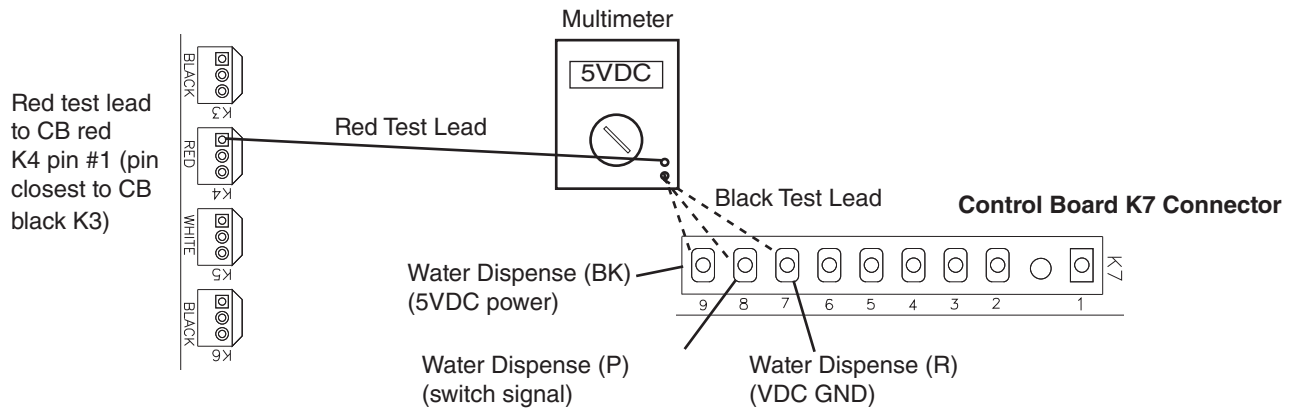

Fig. 4

b) Ice Dispense

1. Push Button Model

CB K7 connector pins #2 (Y) and #3 (W/BK): "ICE" and "AM" LEDs are on: Before engaging the ice dispense switch, check for the correct VDC from the locations given in the "Disengaged" column in the table below. If the VDC is different than in the table, replace CB. If the VDC is correct, engage the ice dispense switch. "ICE" LED turns on. If not, check the ice dispense switch continuity when engaged (closed). If the ice dispense switch is open when engaged, replace. If the VDC matches the "Engaged" column below and the "ICE" LED does not turn on, replace CB.

5VDC CB K7 Connector					
Component	Pin # (Wire Color)	To	CB VDC Ground	Disengaged	Engaged
5VDC Power Supply	#3 (W/BK)	To	Red K4 pin #1 (closest to CB black K3)	5VDC	5VDC
Ice Dispense Signal	#2 (Y)			0VDC	5VDC

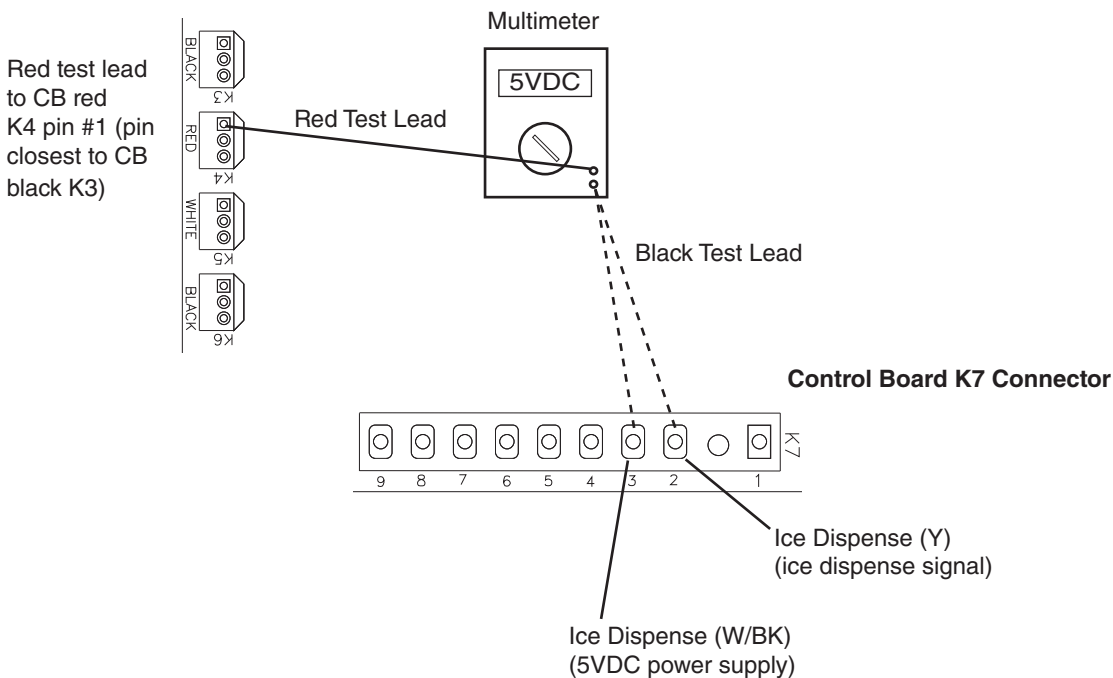

Fig. 5

2. Opti-Serve Model

CB K8 pin #1 (W/R), pin #2 (Y), and pin #3 (W/BK): Before engaging the ice dispense OS sensor, check for the correct VDC from the locations given in the "Disengaged" column in the table below. If the VDC is different than in the table, replace CB. If the VDC reading is correct, engage the OS sensor. "ICE" LED turns on. If not, confirm that the ice dispense signal VDC matches the "Engaged" column in the table below. If not, replace the OS sensor. If the VDC matches the "Engaged" column below and the "ICE" LED does not turn on, replace CB.

5VDC CB K7 Connector					
Component	Pin # (Wire Color)	To	CB VDC Ground	Disengaged	Engaged
VDC Sensor Ground	#1 (W/R)	To	Red K4 pin #1 (closest to CB black K3)	0VDC	0VDC
Ice Dispense Signal	#2 (Y)			0VDC	5VDC
5VDC Power Supply	#3 (W/BK)			5VDC	5VDC

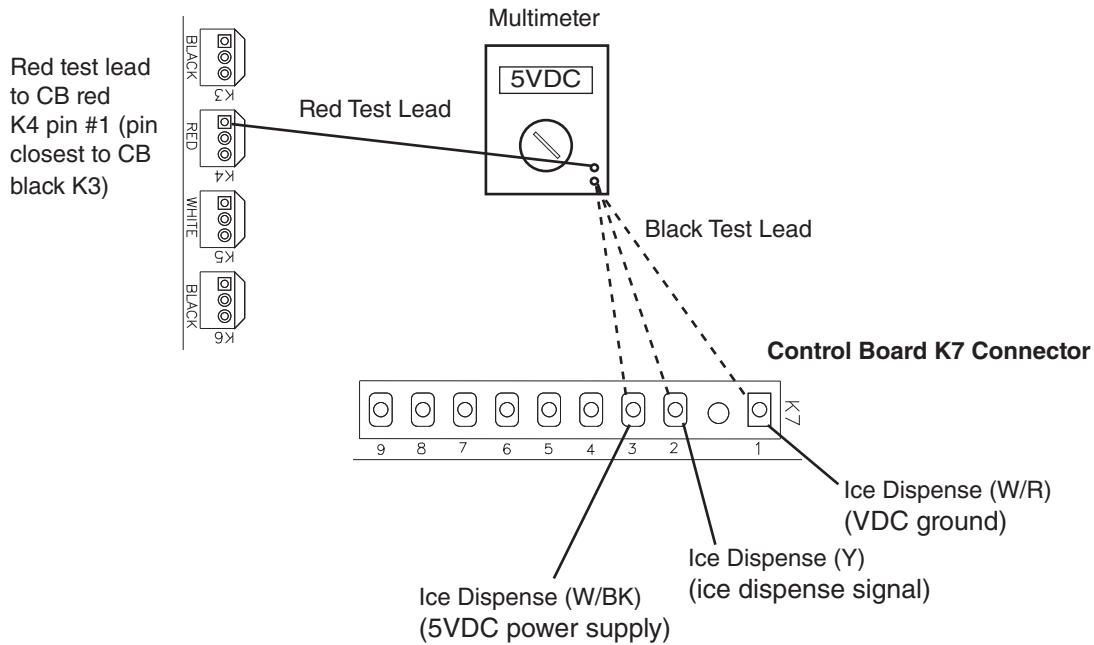

Fig. 6

- 3) **Fill Cycle—"WTRIN" LED is on:** "WTRIN" LED turns on only when the reservoir water level is low enough to open LFS. **Diagnosis:** Confirm LFS is open. If "WTRIN" LED is off and LFS is open and the control switch is in the "ICE" position (open), replace CB. If "WTRIN" LED is on and water is not filling the reservoir, check for 24VAC at CB K2 connector between pin #8 (O) and neutral (LBU). If the "WTRIN" LED is on and 24VAC is not present between CB K2 connector pin # 8 (O) and neutral (LBU), confirm 24VAC at CB K2 connector between pin #7 (W/R) and neutral (LBU). If 24VAC is present between CB K2 connector pin #7 (W/R) and neutral (LBU) and not between CB K2 connector pin #8 (O) and neutral (LBU), replace CB.

24VAC CB K2 Connector					
Connector	Pin # (Wire Color)	To	Neutral (LBU)	LFS Open	LFS Closed
K2 (CB input power)	Pin #7 (W/R)	To	K8 pin #2 (LBU)	24VAC	24VAC
K2 (WV power)	Pin #8 (O)			0VAC	24VAC

- 4) **Ice Purge Cycle—"GM" LED is on:** "GM" LED turns on once UFS closes (reservoir full). If UFS is closed and "GM" LED is off, replace CB. If "GM" LED is on but GM does not start, check for 115VAC from CB K1 connector pin #3 (P) to neutral (W). If 115VAC is not present, confirm 115VAC from CB K1 connector pin #2 (BK) to neutral (W). If 115VAC is present on CB K1 connector pin #2 (BK) but not on CB K1 connector pin #3 (P), replace CB. Once GM energizes, CCR energizes and PT (5-min.) starts.
- 5) **Freeze Cycle—"GM" and "COMP" LED are on:** PT terminates or press the "SERVICE" button on CB after the "GM" LED turns on to bypass ice purge cycle. **WARNING! Risk of electric shock. Care should be taken not to touch live terminals.** After PT terminates, "COMP" LED turns on. If not, confirm CCR contacts are closed. See step "(1)c). Compressor control relay" above. If CCR contacts are closed, replace CB. If "COMP" LED turns on and Comp does not start, check for 115VAC from the CB X1 black (BK) wire and red (R) wire to neutral (W). If 115VAC is present on CB X1 black (BK) wire and not on CB X1 red (R) wire, replace CB. If 115VAC is present on CB X1 red (R) wire and Comp is not energized, CB operation confirmed, check Comp external overload, start capacitor, start relay, motor windings, locked rotor.

Legend: **AM**—agitating motor (gear motor this model); **BC**—bin control; **CB**—control board; **CCR**—compressor control relay; **Comp**—compressor; **CT**—control transformer; **DV**—drain valve; **FM**—fan motor; **FT**—fill timer (90-sec. low water safety); **GM**—gear motor; **PT**—purge timer; **LFS**—lower float switch; **UFS**—upper float switch; **WV**—inlet water valve

D. Bin Control Check

When BC (micro-switch) is not engaged, BC circuit (CB K8 #3 (GY) and CB K8 #4 (GY)) is closed and the appliance produces ice. When ice fills the bin and engages BC large balance plate, BC opens.

NOTICE! Do not place S1 dip switch 7 or S1 dip switch 8 out of the factory default position. These dip switches must be left in the factory default position or the appliance will not operate correctly. For details, see "III.C.1. Default Dip Switch Settings."

CB dip switch 8 and 9 off; CB starts the 90-60 shutdown sequence.

- 1) Move the power switch to the "OFF" position.
- 2) Remove the front, top, and left side panels.
- 3) Move the control switch to the "OFF" position.
- 4) Remove the thumbscrews securing the storage bin cover. **WARNING! Keep hands, hair, and loose clothing clear of the agitator rotating inside of the storage bin.**
- 5) Disconnect BC connector from the back of the control box.
- 6) Check for continuity across BC micro-switch. If BC large balance plate is not engaged and BC micro-switch is open, replace BC micro-switch.
- 7) Press and hold BC large balance plate. While BC large balance plate is engaged, check for continuity across BC micro-switch. If BC large balance plate is engaged and BC micro-switch is open, replace BC micro-switch.
- 8) Disengage BC large balance plate.
- 9) Reconnect BC connector. Remove the control box cover.
- 10) Move the control switch to the "ICE" position, then move the power switch to the "ON" position.
- 11) Make sure the "GM" LED is on. There is a delay of at least 5 seconds before the "GM" LED turns on after power-up. After the "GM" LED turns on, press the "SERVICE" button on CB to bypass the ice purge timer. **WARNING! Risk of electric shock. Care should be taken not to touch live terminals.** "COMP" LED turns on.
- 12) When Comp starts, press and hold BC large balance plate.
- 13) 90-sec. Comp shutdown timer starts. Once 90-sec. Comp shutdown timer terminates, Comp de-energizes and 60-sec. GM shutdown timer starts. Once 60-sec. GM shutdown timer terminates, GM and FM de-energize.
Diagnosis: If BC micro-switch is found open and the appliance continues to run, replace CB.
- 14) Move the power switch to the "OFF" position. Leave the control switch in the "ICE" position.
- 15) Replace the storage bin cover and secure.
- 16) Replace the control box cover, left side, top, and front panels in their correct positions.
- 17) Move the power switch to the "ON" position to start the automatic icemaking process.

Legend: **BC**—bin control; **CB**—control board; **Comp**—compressor; **FM**—fan motor; **GM**—gear motor

E. Float Switch Check and Cleaning

1. Float Switch Check

- 1) Remove the front, top, and left side panels, then move the control switch to the "DRAIN" position.
- 2) After the water has drained from the reservoir, remove the FS molex plug from the control box and check continuity across FS wires. Common (BK) to UFS (R) and common (BK) to LFS (BU). See Fig. 7. With the reservoir empty, float switches are open. If open, continue to step 3. If closed, follow the steps in "II.E.2. Float Switch Cleaning." After cleaning, check them again. Replace if necessary.
- 3) Replace the FS molex plug on the control box.
- 4) Move the control switch to the "ICE" position.
- 5) The reservoir fills. Once UFS closes GM starts.
- 6) Move the control switch to the "OFF" position.
- 7) Remove the FS molex plug from the control box and check continuity across FS wires. Common (BK) to UFS (R) and common (BK) to LFS (BU). With the reservoir full, float switches are closed. If open, follow the steps in "II.E.2. Float Switch Cleaning." After cleaning, check them again. Replace if necessary.
- 8) Move the control switch to the "ICE" position.
- 9) Replace the left side, top, and front panels in their correct positions.

2. Float Switch Cleaning

Depending on water conditions, scale may build up on FS. Scale on the switch can cause the floats to stick. In this case, FS should be cleaned and checked.

- 1) Remove the front, top, and left side panels, then move the control switch to the "DRAIN" position.
- 2) After the water has drained from the reservoir, move the control switch to the "OFF" position and the power switch to the "OFF" position.
- 3) Remove FS assembly from the reservoir cover. See Fig. 8.
- 4) Wipe down FS assembly with a mixture of 1 part Hoshizaki Scale Away and 25 parts warm water. Rinse the FS assembly thoroughly with clean water.
- 5) While not necessary, the floats can be removed from the shaft during cleaning. If you remove them, note that the blue float is on top. The floats must be installed with the magnets inside them towards the top of the switch. See Fig. 8. Installing the floats upside down will affect the timing of FS operation.
- 6) Rinse FS assembly thoroughly with clean water and replace in its correct position.
- 7) Move the control switch to the "ICE" position.
- 7) Replace the left side, top, and front panels in their correct positions.
- 8) Move the power switch to the "ON" position to start the automatic icemaking process.

Legend: **Comp**—compressor; **FS**—float switch; **GM**—gear motor

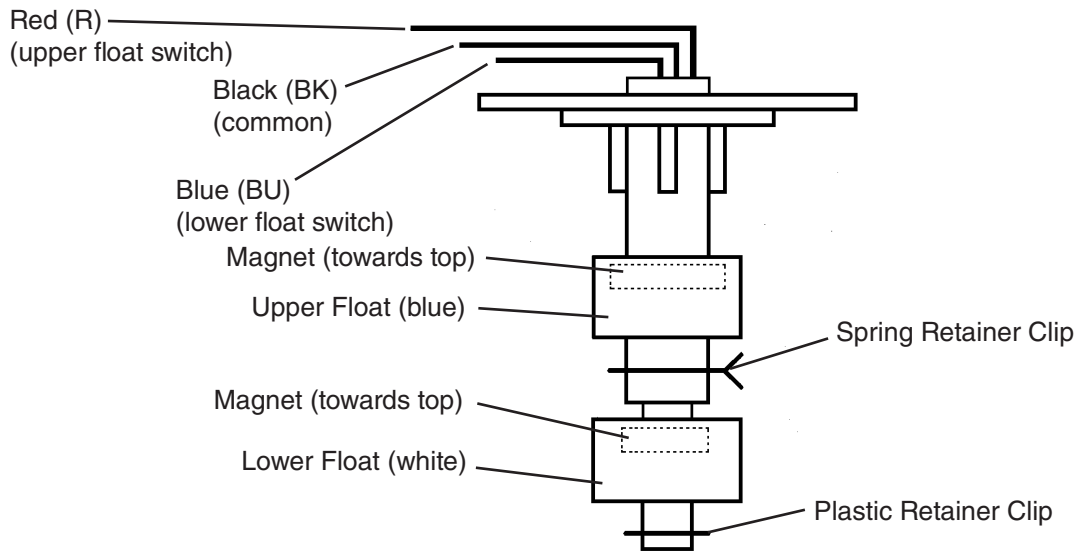

Fig. 7

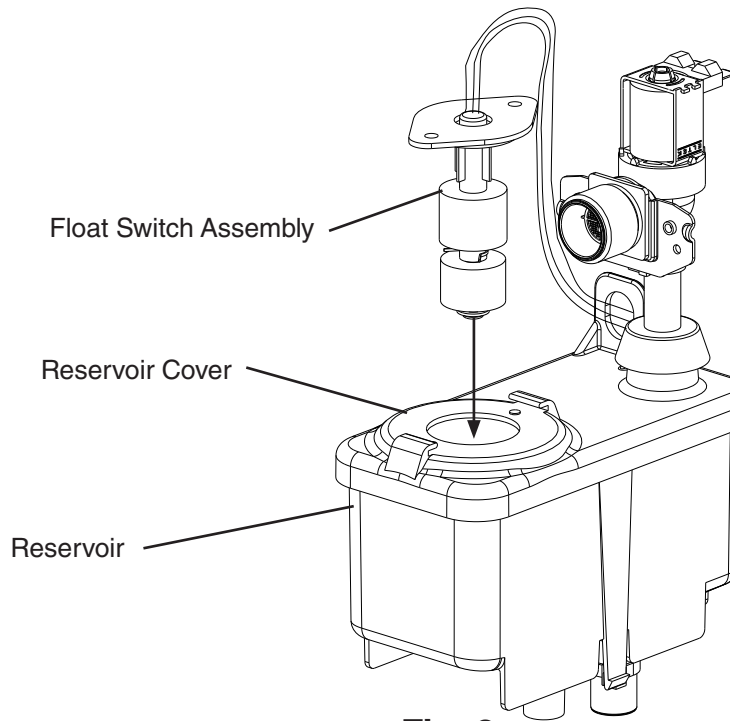

Fig. 8

F. Diagnostic Tables

Before consulting the diagnostic tables, check for correct installation, proper voltage per appliance nameplate, and adequate water pressure (10 to 113 PSIG). Check control board using the steps in "II.C. Control Board Check."

1. No Ice Production

No Ice Production - Possible Cause	
Startup	
1. Power Supply	a) Unplugged, off, blown fuse, tripped or defective circuit breaker. b) Loose connection. c) Not within specifications.
2. Cord and Plug	a) Loose connection. b) Defective.
3. Wiring	a) Loose connection. b) Faulty.
4. Power Switch	a) "OFF" position. b) Defective.
5. Control Transformer	a) Coil winding open or shorted.
6. 1A 24VAC Fuse (Control Box)	a) Defective.
7. Control Switch	a) In "DRAIN" position. b) Defective.
8. Control Board See "II.C. Control Board Check"	a) In alarm. See "III.B. LED Lights and Audible Alarm Safeties." b) Defective.
9. Bin Control	a) Tripped with bin filled with ice. b) Micro-switch defective. c) Large balance plate does not move freely.
10. High-Pressure Switch	a) Control board in 3 or 4-beep alarm. See "III.B. LED Lights and Audible Alarm Safeties."
Fill Cycle	
1. Control Board	a) No power to inlet water valve (24VAC). b) No power to float switch (5VDC) or not reading float switch condition.
2. Inlet Water Valve	a) Screen or orifice clogged. b) Coil winding.
3. Water Supply	a) Water supply off or improper water pressure. b) External water filters clogged.
4. Float Switch	a) Float does not move freely. b) Defective.
5. Drain Valve	a) Sticking.

No Ice Production - Possible Cause	
Ice Purge Cycle	
1. Control Board See "I.C. Control Board Check"	a) No power to gear motor.
2. Gear Motor	a) 3A external protector tripped.
	b) Internal protector open.
	c) Motor winding.
	d) Mechanical failure.
3. Coupling	a) Defective.
4. Compressor Control Relay	a) Defective.
Freeze Cycle	
1. Control Board See "I.C. Control Board Check"	a) No power to compressor control relay circuit (5VDC) or not reading circuit.
	b) Compressor relay defective
2. Start Relay	a) Defective.
3. Start Capacitor	a) Defective.
4. Compressor	a) External protector.
	b) Motor winding.
	c) Mechanical failure.
5. High-Pressure Switch Activates	a) Dirty condenser.
	b) Ambient temperature too warm.
	c) Fan motor not operating.
	d) Refrigerant overcharged.
	e) Defective.
	f) Refrigerant lines or components restricted.
6. Fan Motor	a) Capacitor defective.
	b) Motor winding.
	c) Bearing worn out or locked rotor.
7. Evaporator	a) Dirty.
	b) Damaged or defective.
8. Thermostatic Expansion Valve (TXV)	a) Bulb loose.
	b) Operating erratically.
9. Refrigerant Charge	a) Low.
10. Drain Valve	a) Dirty, leaking by.
	b) Defective coil.
	c) Defective control board.
11. Water System	a) Water leaks.

No Ice Production - Possible Cause	
Refill	
1. Water Supply	a) Off.
2. Control Board	a) No power to float switch (5VDC) or not reading float switch condition.
	b) No power to inlet water valve (24VAC).
3. Float Switch	a) Float does not move freely.
	b) Defective.
4. Inlet Water Valve	a) Clogged or defective.
Shutdown	
1. Bin Control	a) Large balance plate sticking.
	b) Micro-switch defective.
2. Control Board See "II.C. Control Board Check"	a) S1 dip switch settings not set correctly.
	b) Defective.

2. Ice/Water Dispensing

Ice Dispense-Push Button	
1. Power Supply	a) Off, blown fuse, or tripped breaker.
2. Control Board	a) No power from control board to dispense board (5VDC) or not reading signal.
	b) No power to ice dispense solenoid or dispense relay (115VAC).
3. Dispense Board	a) Defective.
4. Gear Motor	a) Defective.
5. Shutter Assembly	a) Defective.
Ice Dispense-Opti-Serve	
1. Power Supply	a) Off, blown fuse, or tripped breaker.
2. Control Board See "II.C. Control Board Check"	a) No power from control board to OS sensor (5VDC) or not reading signal.
	b) No power to ice dispense solenoid or dispense relay (115VAC).
3. OS Sensor (infrared)	a) Defective.
4. Ice Dispense Solenoid	a) Defective or loose connection.
5. Gear Motor	a) Defective.
6. Shutter Assembly	a) Defective.

Water Dispense-Push Button	
1. Power Supply	a) Off, blown fuse, or tripped breaker.
2. Control Board See "II.C. Control Board Check"	a) No power from control board to dispense board (5VDC) or not reading signal.
	b) No power to dispense water valve (24VAC).
3. Dispense Board	a) Defective.
4. Water Dispense Valve	a) Water supply turned off.
	b) Defective.
Water Dispense-Opti-Serve	
1. Power Supply	a) Off, blown fuse, or tripped breaker.
2. Control Board See "II.C. Control Board Check"	a) No power from control board to OS sensor (5VDC) or not reading signal.
	b) No power to water dispense valve (24VAC).
3. OS Sensor (infrared)	a) Defective.
4. Water Dispense Valve	a) Water supply turned off.
	b) Defective.

III. Controls and Adjustments

- A Hoshizaki exclusive control board is employed in DCM series appliances.
- All models are pre-tested and factory adjusted.
- For a control board check procedure, see "II.C. Control Board Check."

<i>NOTICE</i>
<ul style="list-style-type: none">• The control board is fragile; handle very carefully.• The control board contains integrated circuits, which are susceptible to failure due to static discharge. It is especially important to touch the metal part of the icemaker before handling or replacing the control board.• Do not touch the electronic devices on the control board or the back of the control board.• Do not change wiring and connections. Do not misconnect terminals.• Do not short out power supply to test for voltage.• Always replace the whole control board assembly if it goes bad.

A. Control Board Layout

1. DCM-271BAH

a) Control Board

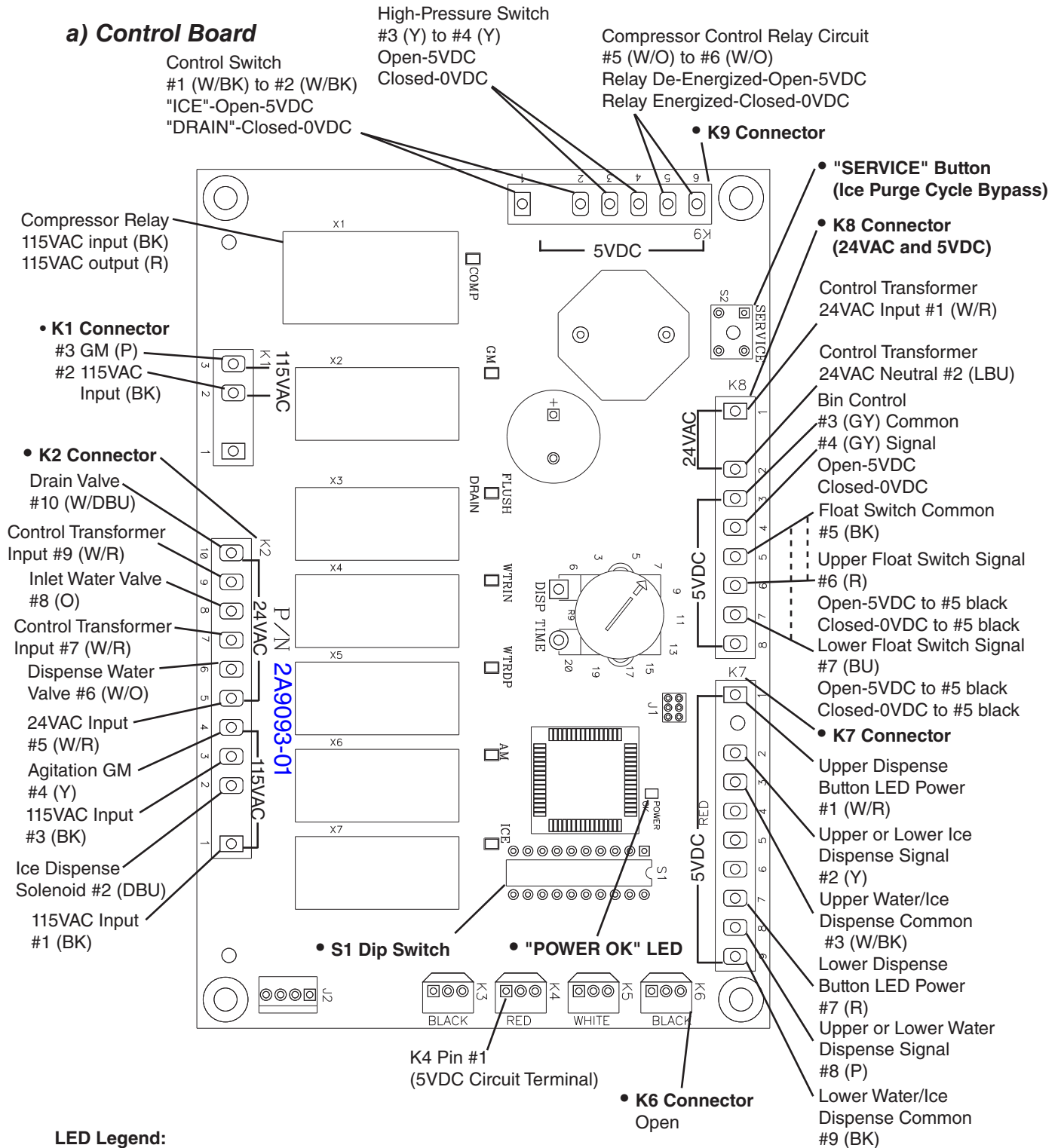

- LED Legend:**
COMP-compressor
FLUSH (DRAIN)-drain valve
GM-gear motor
ICE-dispense motor
WTRDP-water dispense valve
WTRIN-inlet water valve

Control Board	
Part Number	2A9093-01

Fig. 9a

b) Upper/Lower Water and Ice Dispense Board

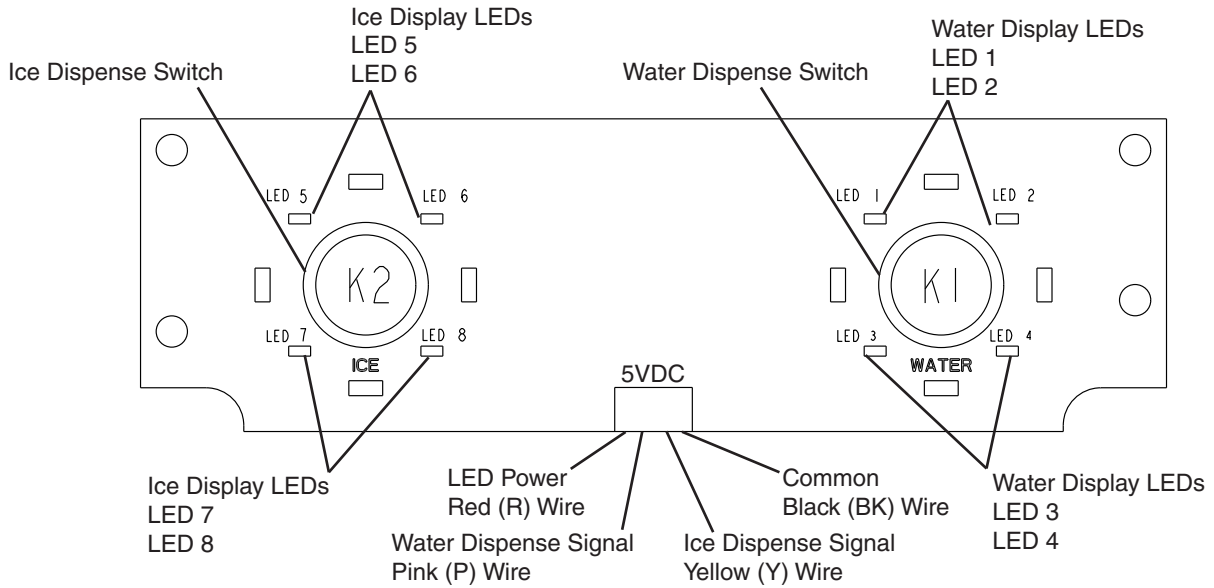

Water/Ice Dispense Board	
Part Number	2A9214-01

2. DCM-271BAH-OS

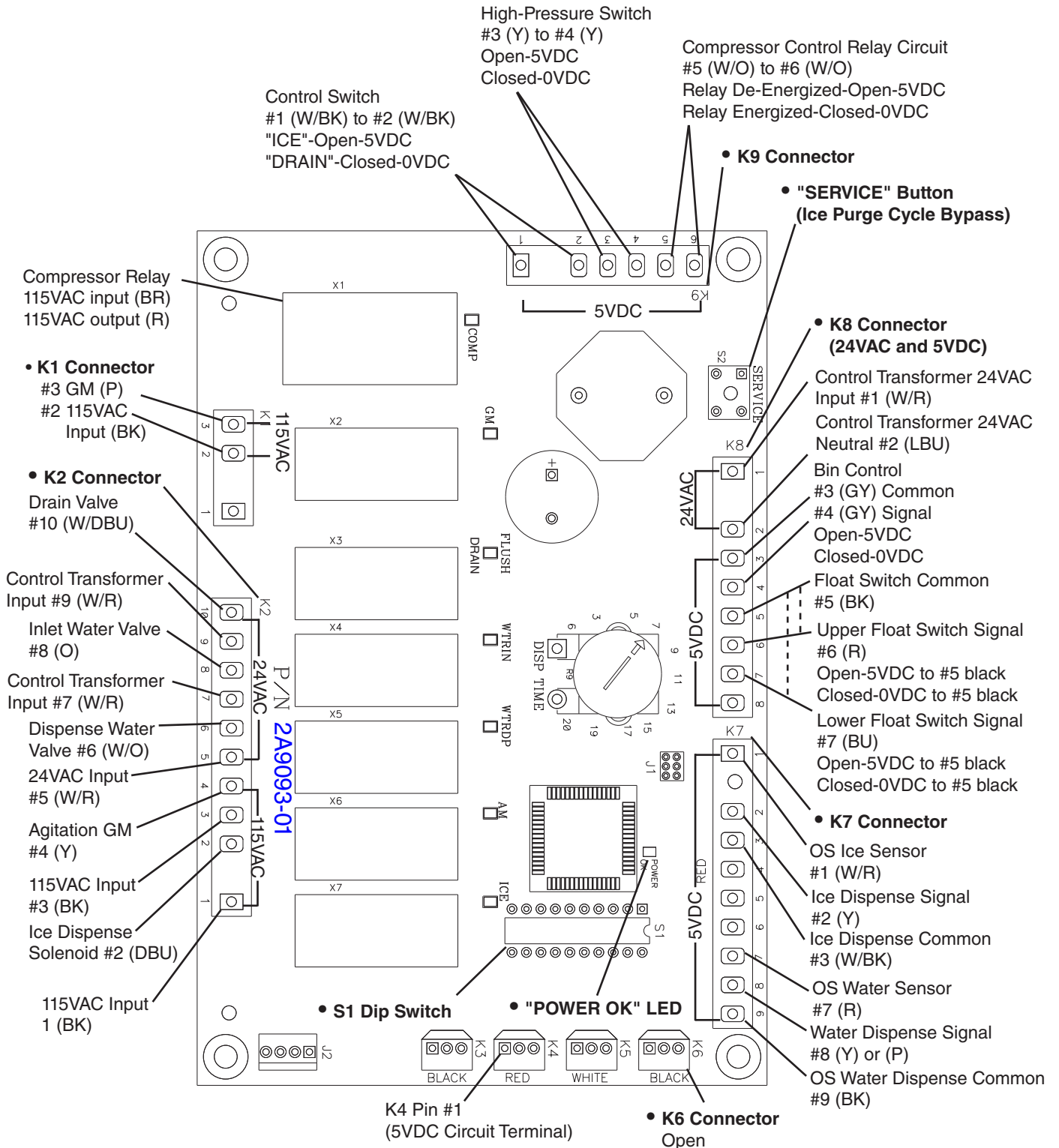

- LED Legend:**
COMP-compressor
FLUSH (Drain)-drain valve
GM-gear motor
ICE-dispense motor
WTRDP-water dispense valve
WTRIN-inlet water valve

Control Board	
Part Number	2A9093-01

Fig. 9b

B. LED Lights and Audible Alarm Safeties

The "POWER" LED indicates proper control voltage and will remain on unless a control voltage problem occurs. For further details, see "II. B. Service Diagnosis."

Icemaking Sequence				
Sequence Step	LED	Energized Components	Min.	Max.
Fill Cycle	WTRIN	WV		On until UFS closes. Alarm sounds after 90 sec.
Ice Purge Cycle	GM	GM, FM	5 min.	5 min.
Freeze Cycle (with refill)	GM, WTRIN* (refill), COMP	GM, Comp, FM, WV* (refill)		*On until UFS closes. Alarm sounds after 90 sec.
1-1 hr or 1-12 hr Drain Cycle	FLUSH (Drain) Do not adjust for 1-12 on this model.	1-in-1: DV- Icemaker status does not change 1-in-12: DV	2 sec.	10 min.
Dispensing Sequence				
Sequence Step	LED	Energized Components	Time LEDs are on	**Dispense Mode
				Continuous
Ice Dispense Activation	ICE	GM, **IDSV	Factory set for 20 sec.	IDSV de-energizes on internal overload after 3 to 4 min. Resets when cool
Dispense Water Valve Activation	WTRDP	DispWV		

The built-in safeties shut down the appliance and have alarms as listed below.

No. of Beeps (every 5 sec.)	Type of Alarm	Reset Options
1	Low Water Safety UFS open > 90 seconds after WV energized.	Automatic reset once water supply is restored and UFS closes.
2	Control Switch In "DRAIN" position longer than 15 minutes.	Automatic reset once the control switch is moved to the "ICE" position.
3	High-Pressure Switch First and second activation in 1 hour.	Automatic reset once pressure drops below the high pressure threshold and the high-pressure switch closes.
4	High-Pressure Switch Third activation in 1 hour.	Call for service. To avoid possible catastrophic failure, it is recommended to leave the appliance off until this alarm is resolved. Manual reset. Turn power off and on again.
5	Freeze Timer WV off > 30 minutes since last WV activation.	Manual reset. Turn power off and on again.
6	Low Voltage (92Vac ±5% or less)	"POWER OK" LED turns off if voltage protection operates.
7	High Voltage (147Vac ±5% or more)	The control voltage safeties automatically reset when voltage is corrected.
8	Gear Motor CCR contacts fail to close.	Manual reset. Turn power off and on again.
9	Open Circuit CB K8 #3 and #4. (CB S1 dip switch 7 on) Not used this model.	Manual reset. Turn power off and on again.

Legend: **CB**—control board; **CCR**—compressor control relay; **Comp**—compressor;
DispWV—dispense water valve; **DV**—drain valve; **FM**—fan motor; **GM**—gear motor;
IDSV—ice dispense solenoid valve; **MBC**—mechanical bin control; **UFS**—upper float switch; **WV**—inlet water valve

C. Settings and Adjustments

1. Default Dip Switch Settings

The S1 dip switch settings are factory-set to the following positions:

Dip Switch No.	1	2	3	4	5	6	7	8	9	10
DCM-271BAH(-OS)	OFF	OFF	OFF	OFF	ON	OFF	OFF	OFF	OFF	OFF

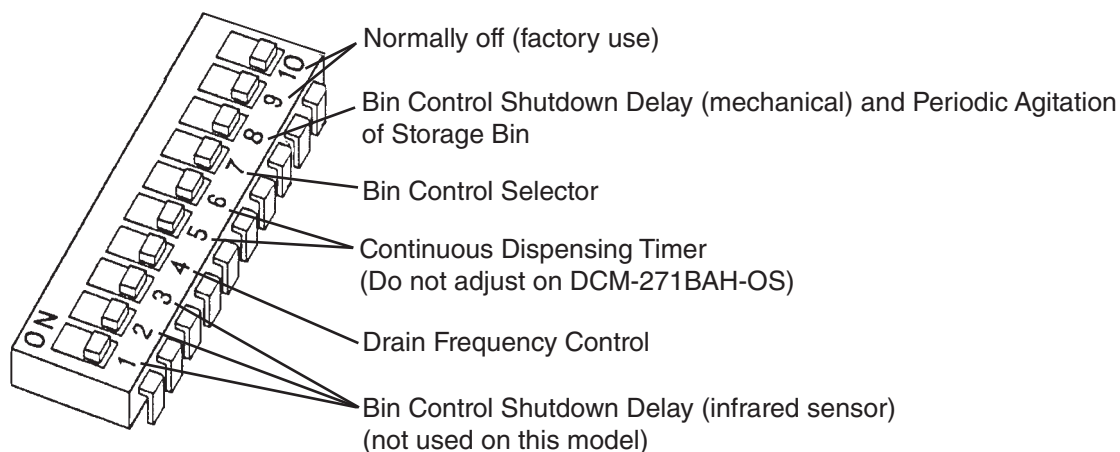

2. Bin Control Shutdown Delay (Infrared Sensor) (S1 dip switch 1, 2, 3)

NOTICE

Do not adjust. Setting not used on this model. When dip switch 7 is off, dip switch 1, 2, and 3 are ignored.

Factory set. DCM-271BAH(-OS) does not use a bin control with an infrared sensor. The appliance uses a bin control with a mechanical micro-switch for ice level control.

3. Drain Frequency Control (S1 dip switch 4)

The appliance is factory set for optimum performance with the 1-in-1 drain cycle (S1 dip switch 4 in the "OFF" position). This setting allows for removal of sediment from the evaporator without interrupting the icemaking process. **NOTICE! Do not adjust S1 dip switch 4 out of the factory default position. This dip switch must be left in the factory default position or the appliance will not operate correctly.**

S1 Dip Switch Setting	Drain Timer Interval	Drain Valve Open
No. 4		
OFF (1-in-1)	1 Hour	2 Seconds
ON (1-in-12)	11 Hours 45 Minutes	10 Minutes

4. Continuous Dispensing Timer (S1 dip switch 5 & 6)

The factory setting allows ice to be dispensed continuously for 20 sec. The DCM-271BAH may be adjusted to other dispense time options.

NOTICE! On DCM-271BAH-OS, do not adjust S1 dip switch 5 & 6 out of the factory default position.

S1 Dip Switch Setting		Dispense Time
No. 5	No. 6	
OFF	OFF	No Limit
ON	OFF	20 Seconds
OFF	ON	60 Seconds
ON	ON	No Limit

Note: The ice dispense solenoid has an internal overload protector. When set to "No Limit" the internal protector may open if ice dispense solenoid is energized longer than 3 to 4 min. at one time.

5. Bin Control Selector (S1 dip switch 7)

The appliance is factory set with mechanical bin control operation. No adjustment is required. In the factory default position (S1 dip switch 7 in the off position), the gear motor delay after the upper float switch closes is 5 seconds. **WARNING! Do not adjust S1 dip switch 7 out of the factory default position. This dip switch must be left in the factory default position or the appliance will not operate correctly.**

S1 Dip Switch Setting	Bin Control Application	Gear Motor Delay
No. 7		
OFF	Bin Control (Mechanical)	5 seconds
ON	Bin Control (Infrared Sensor) with optional Mechanical Bin Control Backup	30 seconds

6. Bin Control Shutdown Delay, Agitation, and Ice Purge Timer (S1 dip switch 8)

The shutdown delay is the time between the bin control micro-switch opening and the control board shutting down the appliance. **WARNING! Do not adjust S1 dip switch 8 out of the factory default position. This dip switch must be left in the factory default position or the appliance will not operate correctly.**

S1 Dip Switch Setting	Storage Bin Periodic Agitation	Ice Purge Timer
No. 8		
OFF	2 Seconds	60 Seconds (1 min.)
ON	No Agitation	300 Seconds (5 min.)

7. Bin Control Shutdown Delay (S1 dip switch 9)

The shutdown delay is the time between the bin control micro-switch opening and the control board shutting down the appliance. **WARNING! Do not adjust S1 dip switch 9 out of the factory default position. This dip switch must be left in the factory default position or the appliance will not operate correctly.**

S1 Dip Switch Setting	Bin Control Shutdown Delay
No. 9	
OFF	90-60 Second Sequence (150 sec. total)
ON	6 to 10 Seconds

8. Audible Alarm Silencer (S1 Dip Switch 10)

This setting allows audible alarms (beeps) to be silenced. The default position is "OFF", which allows audible alarms to sound. The default position is recommended as the audible alarms notify the end user and service technicians of issues with the appliance. See "III.B. LED Lights and Audible Alarm Safeties."

S1 Dip Switch Setting	Audible Alarm Silencer
No. 10	
OFF	Audible Alarm Sounds
ON	Audible Alarm Suppressed

D. Switches

The power switch and control switch are used to control the operation of this icemaker.

1. Power Switch

The power switch has 2 positions, "OFF" and "ON."

2. Control Switch

The control switch is a double-pole double-throw switch with 3 positions, "ICE," "OFF," and "DRAIN."

a) ICE

When the control switch is in the "ICE" position;

Pole #1 (W/R) (24VAC) closes and 24VAC is present at CB K8 pin #1.

Pole #2 (W/BK) (5VDC) is an open circuit for "ICE" between CB K9 pin #1 and CB K9 pin #2. 5VDC is present between CB K9 pin #1 and CB K9 pin #2, and the automatic icemaking process starts.

b) OFF

When the control switch is in the "OFF" position, pole #3 is open and 24VAC is removed from K8 pin #1 and the icemaker is off.

c) DRAIN

When the control switch is in the "DRAIN" position;

Pole #1 (W/R) (24VAC) closes and 24VAC is present at CB K8 pin #1.

Pole #2 (W/BK) (5VDC) is a closed circuit for "DRAIN" between CB K9 pin #1 and CB K9 pin #2. 0VDC is present between CB K9 pin #1 and CB K9 pin #2, and the drain process starts.

IV. Refrigeration Circuit and Component Service Information

⚠ WARNING

- This appliance should be diagnosed and repaired only by qualified service personnel to reduce the risk of death, electric shock, serious injury, or fire.
- Move the power switch to the "OFF" position, then unplug the appliance from the electrical outlet before servicing.
- **CHOKING HAZARD:** Ensure all components, fasteners, and thumbscrews are securely in place after the icemaker is serviced. Make sure that none have fallen into the ice storage bin.
- Make sure all food zones in the icemaker and dispenser unit/ice storage bin are clean after service.
- When replacing evaporator assembly and water circuit components, make sure there are no water leaks after the repair is complete.

A. Refrigeration Circuit Service Information

⚠ WARNING

- Repairs requiring the refrigeration circuit to be opened must be performed by properly trained and EPA-certified service personnel.
- Use an electronic leak detector or soap bubbles to check for leaks. Add a trace of refrigerant to the system (if using an electronic leak detector), and then raise the pressure using nitrogen gas (140 PSIG). Do not use R-404A as a mixture with pressurized air for leak testing.

NOTICE

- Always recover the refrigerant and store it in an approved container. Do not discharge the refrigerant into the atmosphere.
- Do not leave the system open for longer than 15 minutes when replacing or servicing parts. The Polyol Ester (POE) oils used in R-404A units can absorb moisture quickly. Therefore it is important to prevent moisture from entering the system when replacing or servicing parts.
- Always install a new drier every time the sealed refrigeration system is opened. Do not replace the drier until after all other repair or replacement has been made. Install the new drier with the arrow on the drier in the direction of the refrigerant flow.
- When brazing, protect the drier by using a wet cloth to prevent the drier from overheating. Do not allow the drier to exceed 250°F (121°C).

1. Refrigerant Recovery

This icemaker is provided with refrigerant access valves. Using proper refrigerant practices, recover the refrigerant from the service valves and store it in an approved container. Do not discharge the refrigerant into the atmosphere.

2. Brazing

⚠ WARNING

- R-404A itself is not flammable at atmospheric pressure and temperatures up to 176°F (80°C).
- R-404A itself is not explosive or poisonous. However, when exposed to high temperatures (open flames), R-404A can be decomposed to form hydrofluoric acid and carbonyl fluoride both of which are hazardous.
- Do not use silver alloy or copper alloy containing arsenic.
- Use an electronic leak detector or soap bubbles to check for leaks. Add a trace of refrigerant to the system (if using an electronic leak detector), and then raise the pressure using nitrogen gas (140 PSIG). Do not use R-404A as a mixture with pressurized air for leak testing.

- 1) Braze all fittings while purging with nitrogen gas flowing at a pressure of 3 to 4 PSIG.

NOTICE

- Always install a new drier every time the sealed refrigeration system is opened.
- Do not replace the drier until after all other repair or replacement has been made. Install the new drier with the arrow on the drier in the direction of the refrigerant flow.
- When brazing, protect the drier by using a wet cloth to prevent the drier from overheating. Do not allow the drier to exceed 250°F (121°C).

- 2) Use an electronic leak detector or soap bubbles to check for leaks. Add a trace of refrigerant to the system (if using an electronic leak detector), and then raise the pressure using nitrogen gas (140 PSIG). Do not use R-404A as a mixture with pressurized air for leak testing.

3. Evacuation and Recharge (R-404A)

- 1) Attach a vacuum pump to the system. Be sure to connect charging hoses to both high and low-side access valves.

IMPORTANT

The vacuum level and vacuum pump may be the same as those for current refrigerants. However, the rubber hose and gauge manifold to be used for evacuation and refrigerant charge should be exclusively for POE oils.

- 2) Turn on the vacuum pump. Open the gauge manifold valves. Never allow the oil in the vacuum pump to flow backwards.
- 3) Allow the vacuum pump to pull down to a 29.9" Hg vacuum. Evacuating period depends on pump capacity.
- 4) Close the low-side valve and high-side valve on the gauge manifold.

- 5) Disconnect the gauge manifold hose from the vacuum pump and attach it to a refrigerant service cylinder. Remember to loosen the connection and purge the air from the hose. See the rating label inside the icemaker for the required refrigerant charge. Hoshizaki recommends only virgin refrigerant or reclaimed refrigerant which meets ARI Standard 700 (latest edition) be used.
- 6) A liquid charge is required for charging an R-404A system (to prevent fractionation). Place the service cylinder on the scales: if the service cylinder is not equipped with a dip tube, invert the service cylinder, then place it on the scales. Open the high-side valve on the gauge manifold.
- 7) Allow the system to charge with liquid until the proper charge weight is met.
- 8) If necessary, add any remaining charge to the system through the low-side.
NOTICE! To prevent compressor damage, use a throttling valve or liquid dispensing device to add the remaining liquid charge through the low-side access valve with the icemaker running.
- 9) Close the high and low-side gauge manifold valves, then disconnect the gauge manifold hoses.
- 10) Cap the access valves to prevent a possible leak.

B. Component Service Information

NOTICE

- When replacing a component listed below, see the notes to help ensure proper operation.
- When replacing evaporator assembly and water circuit components, make sure there are no water leaks after the repair is complete.
- Seal bolts must be replaced once removed because seal material is one-time use only. If new seal bolts do not have preapplied threadlocker, apply Loctite 243 or equivalent threadlocker to seal bolt threads. Tighten to the torque values listed below.

Torque for F-1001 and Smaller: 11.1 ft-lb/15 N·m. Tighten 2 times. Allow at least 5 sec. in between each tightening.

Component	Notes
Compressor	Install a new drier, start capacitor, and start relay.
Fan Motor	Install a new capacitor.
Thermostatic Expansion Valves	<ul style="list-style-type: none"> • Attach the thermostatic expansion valve bulb to the suction line in the same location as the previous bulb. • The bulb should be between the 10 and 2 o'clock positions on the tube. • Secure the bulb with the clamp and holder, then insulate it.
Upper and Lower Bearings	<ul style="list-style-type: none"> • Inspect the upper bearing for wear. See "IV.C.1. Upper Bearing Wear Check." Replace if necessary. • When replacing the upper bearing it is advised to also change the lower bearing at the same time.
Evaporator	<ul style="list-style-type: none"> • Install a new drier. • Inspect the mechanical seal and O-ring prior to installing the new evaporator. If worn, cracked, or scratched, the mechanical seal should also be replaced.
Gear Motor	Install a new gear motor capacitor.

Icemaking Unit

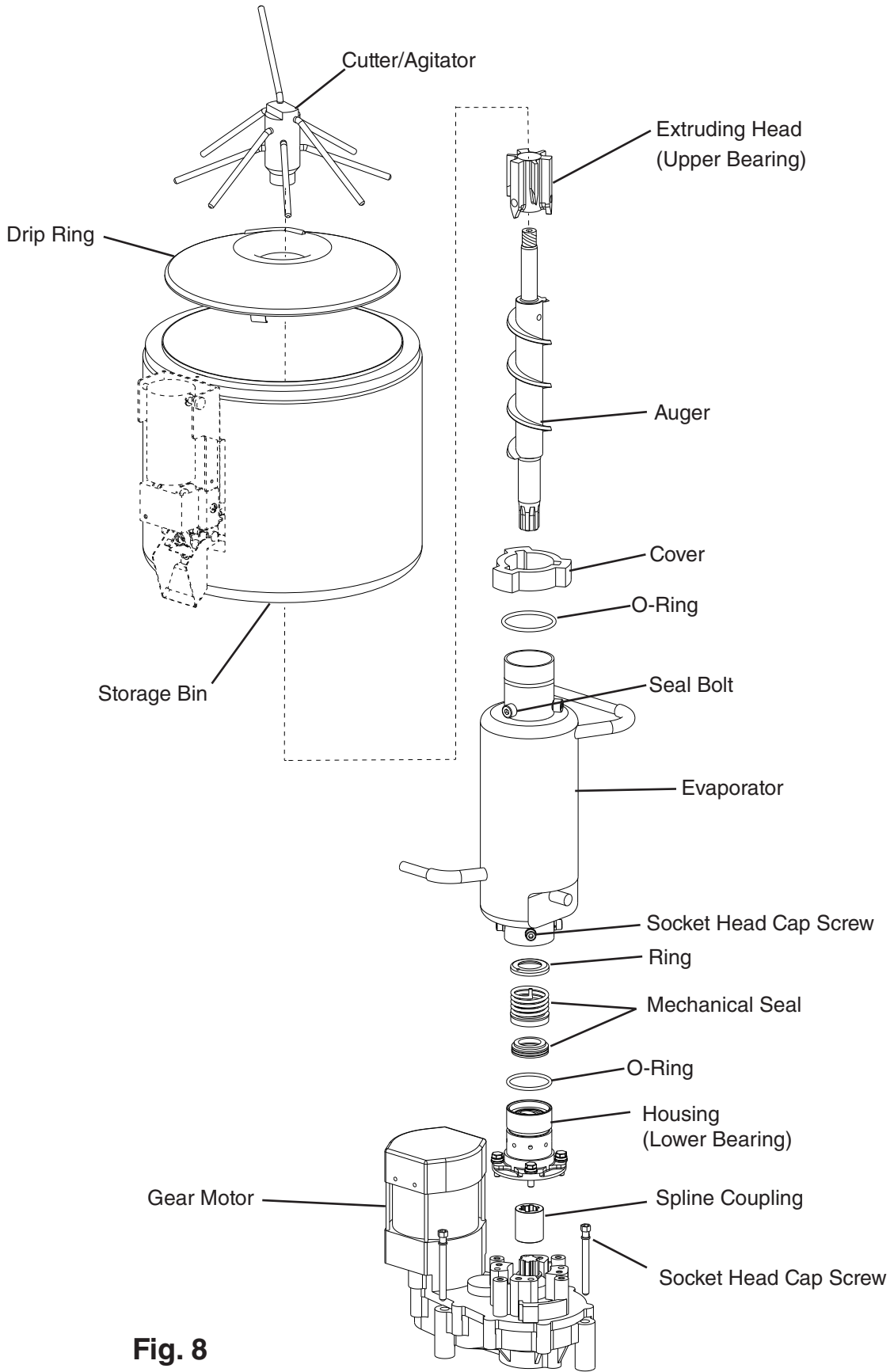

Fig. 8

C. Icemaking Unit

1. Upper Bearing Wear Check

To ensure that the bearing inside the extruding head does not exceed the wear tolerance of .02", follow the instructions below. See Fig. 11.

- 1) Move the power switch to the "OFF" position, then unplug the appliance from the electrical outlet. Remove the front and top panels. On the push-button model, disconnect the push-button switch wire connectors.
- 2) Remove the storage bin top cover, then remove the cutter/agitator by turning it counter-clockwise, then lift the drip ring out of the storage bin.
- 3) Grasp the top of the auger and move the auger towards you, then try to insert a .02" round stock or pin gauge in between the back side of the auger shaft and the bearing surface. Check several locations around the auger shaft. If the gauge goes between the shaft and the bearing at any point or if the bearing is scratched or cracked, both the top bearing in the extruding head and the lower bearing in the lower housing should be replaced. Instructions for removing the extruding head and lower housing are located later in this procedure.

Note: Replacing the bearing requires a bearing press adaptor. If one is not available, replace the whole extruding head and lower housing.

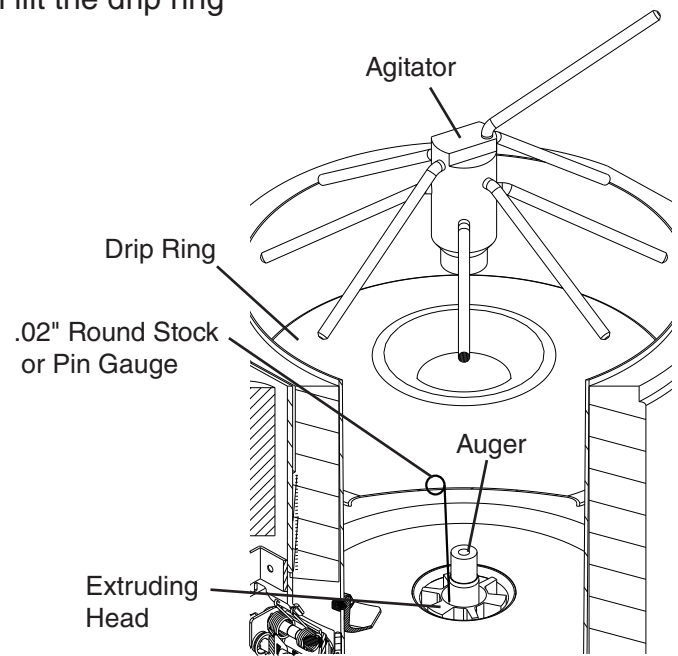

Fig. 3

- 4) Replace the drip ring, cutter/agitator, and storage bin top cover in their correct positions.
- 5) Replace the top and front panels in their correct positions. On the push-button model, reconnect the push-button switch wire connectors.
- 6) Plug the appliance into the electrical outlet. Move the power switch to the "ON" position to start the automatic icemaking process.

2. Icemaking Unit Component Removal and Replacement Preparation

- 1) Move the power switch to the "OFF" position, then remove the right side louver panel.
- 2) Move the control switch to the "DRAIN" position, then move the power switch to the "ON" position and drain the water. Next, place a container under the ice dispense spout. Press the ice dispense button or activate the OS ice sensor and dispense the ice from the storage bin.
- 3) After all the water has drained and all the ice has been dispensed, move the power switch to the "OFF" position, then unplug the appliance from the electrical outlet. Remove the front, top, left, and right panels. On the push-button model, disconnect the push-button switch wire connectors.
- 4) Remove the storage bin top cover and remove any remaining ice from the storage bin.

2a. Removal and Replacement Extruding Head

- 1) Remove the cutter/agitator by turning it counter-clockwise, then lift the drip ring out of the storage bin.
- 2) Remove the seal bolts, then lift the extruding head out of the evaporator.
- 3) Place the new extruding head on the auger. Next, secure the extruding head with new seal bolts and tighten to 11.1 ft-lb/15 N·m. **NOTICE! Seal bolts must be replaced once removed because seal material is one-time use only. If new seal bolts do not have preapplied threadlocker, apply Loctite 243 or equivalent threadlocker to seal bolt threads.**
- 4) Replace the drip ring, cutter/agitator, and storage bin top cover in their correct positions.
- 5) Move the control switch to the "ICE" position, then replace the panels in their correct positions. On the push-button model, reconnect the push-button switch wire connectors.
- 6) Plug the appliance back into the electrical outlet, then move the power switch to the "ON" position to start the automatic icemaking process.

2b. Removal and Replacement of Auger

- 1) Remove the cutter/agitator by turning it counter-clockwise, then lift the drip ring out of the storage bin.
- 2) Remove the seal bolts, then screw the cutter/agitator back on and use it to lift the auger and extruding head out of the evaporator. Remove the extruding head and upper part of the mechanical seal from the auger and place them on the new auger. **NOTICE! To help prevent water leaks, be careful not to damage the surfaces of the O-ring or mechanical seal.**
- 3) Place the new auger assembly back in the evaporator with the upper part of the mechanical seal and extruding head attached. Next, secure the extruding head with new seal bolts and tighten to 11.1 ft-lb/15 N·m. **NOTICE! Seal bolts must be replaced once removed because seal material is one-time use only. If new seal bolts do not have preapplied threadlocker, apply Loctite 243 or equivalent threadlocker to seal bolt threads.**
- 4) Replace the drip ring, cutter/agitator, and storage bin top cover in their correct positions.
- 5) Move the control switch to the "ICE" position, then replace the panels in their correct positions. On the push-button model, reconnect the push-button switch wire connectors.
- 6) Plug the appliance back into the electrical outlet, then move the power switch to the "ON" position to start the automatic icemaking process.

2c. Removal and Replacement of Evaporator

NOTICE

Always install a new drier every time the sealed refrigeration system is opened.
Do not replace the drier until after all other repair or replacement has been made.

- 1) Recover the refrigerant and store it in an approved container.
- 2) Remove the cutter/agitator by turning it counter-clockwise, then lift the drip ring out of the storage bin.
- 3) Remove the seal bolts, then screw the cutter/agitator back on and use it to lift the auger and extruding head out of the evaporator.
- 4) Disconnect the water hoses.
- 5) Disconnect the inlet and outlet tubing.
- 6) Remove the socket head cap screws securing the evaporator to the lower housing.
- 7) Lift off the evaporator.
- 8) Inspect the mechanical seal and O-ring prior to installing the new evaporator. The mechanical seal consists of two parts. One moves along with the auger, and the other is fixed on the lower housing. **NOTICE! If the contact surfaces of these two parts are worn, cracked, or scratched, the mechanical seal may cause water leaks and should be replaced.** Instructions for removing the mechanical seal and lower housing are located later in this procedure.
- 9) Make sure the lower mechanical seal is in place, then place the new evaporator in position. Secure the evaporator to the lower housing using the socket head cap screws.
- 10) Remove the drier, then place the new drier in position. Connect the inlet and outlet tubing to the new evaporator.
- 11) Braze all fittings while purging with nitrogen gas flowing at a pressure of 3 to 4 PSIG.
- 12) Use an electronic leak detector or soap bubbles to check for leaks. Add a trace of refrigerant to the system (if using an electronic leak detector), and then raise the pressure using nitrogen gas (140 PSIG). Do not use R-404A as a mixture with pressurized air for leak testing.
- 13) Evacuate the system, and charge it with refrigerant. See the nameplate for the required refrigerant charge.
- 14) Place the auger assembly back in the evaporator with the upper part of the mechanical seal and extruding head attached. Next, secure the extruding head with new seal bolts and tighten to 11.1 ft-lb/15 N·m. **NOTICE! Seal bolts must be replaced once removed because seal material is one-time use only. If new seal bolts do not have preapplied threadlocker, apply Loctite 243 or equivalent threadlocker to seal bolt threads.**
- 15) Replace the drip ring, cutter/agitator, and storage bin top cover in their correct positions, then reconnect the water hoses.
- 16) Move the control switch to the "ICE" position, then replace the panels in their correct positions. On the push-button model, reconnect the push-button switch wire connectors.
- 17) Plug the appliance back into the electrical outlet, then move the power switch to the "ON" position to start the automatic icemaking process.

2d. Removal and Replacement of Mechanical Seal and Lower Housing

1. Mechanical Seal

- 1) Remove the cutter/agitator by turning it counter-clockwise, then lift the drip ring out of the storage bin.
- 2) Remove the seal bolts, then screw the cutter/agitator back on to the auger and use it to lift the auger out of the evaporator.
- 3) The mechanical seal consists of two parts. One moves along with the auger, and the other is fixed on the lower housing. **NOTICE! If the contact surfaces of these two parts are worn, cracked, or scratched, the mechanical seal may cause water leaks and should be replaced.**
- 4) Remove the socket head cap screws securing the evaporator to the lower housing.
- 5) Lift the evaporator up to access the lower housing.
- 6) Remove the mechanical seal from the lower housing. If only replacing the mechanical seal, proceed to step 9. **NOTICE! To help prevent water leaks, be careful not to damage the surfaces of the O-ring or mechanical seal.**

2. Lower Housing

- 7) Remove the O-ring from the lower housing and the bolts securing the lower housing to the gear motor, then remove the lower housing from the gear motor. If inspection of the upper bearing inside the extruding head (see "IV.C.1. Upper Bearing Wear Check") indicates that it is out of tolerance, replace both it and the bearing inside the lower housing.
Note: Replacing the bearing requires a bearing press adaptor. If one is not available, replace the whole extruding head and lower housing.
- 8) Place the O-ring on to the new lower housing, then mount the lower housing on the gear motor.
- 9) Place the lower part of the mechanical seal on the lower housing.
- 10) Place the evaporator in its correct position, then secure the evaporator to the lower housing using the socket head cap screws.
- 11) Place the auger assembly back in the evaporator with the upper part of the mechanical seal and extruding head attached. Next, secure the extruding head with new seal bolts and tighten to 11.1 ft-lb/15 N·m. **NOTICE! Seal bolts must be replaced once removed because seal material is one-time use only. If new seal bolts do not have preapplied threadlocker, apply Loctite 243 or equivalent threadlocker to seal bolt threads.**
- 12) Replace the drip ring, cutter/agitator, and storage bin top cover in their correct positions. Confirm all water hose connections are secure.
- 13) Move the control switch to the "ICE" position, then replace the panels in their correct positions. On the push-button model, reconnect the push-button switch wire connectors.
- 14) Plug the appliance back into the electrical outlet, then move the power switch to the "ON" position to start the automatic icemaking process.

2e. Removal and Replacement of Gear Motor

- 1) Remove the bolts securing the lower housing to the gear motor. Lift the evaporator up slightly.
- 2) Remove the gear motor bolts.
- 3) Disconnect the wiring from the gear motor, then lift the evaporator up slightly and remove the gear motor.
- 4) Remove the spline coupling from the old gear motor and attach to the new gear motor.
- 5) Place the new gear motor in its correct position and secure.
- 6) Connect the gear motor wires.
- 7) Lower the evaporator down and secure the lower housing to the gear motor.
- 8) Replace the drip ring, cutter/agitator, and storage bin top cover in their correct positions. Confirm all water hose connections are secure.
- 9) Move the control switch to the "ICE" position, then replace the panels in their correct positions. On the push-button model, reconnect the push-button switch wire connectors.
- 10) Plug the appliance back into the electrical outlet, then move the power switch to the "ON" position to start the automatic icemaking process.

V. Maintenance

The maintenance schedule below is a guideline. More frequent maintenance may be required depending on water quality, the appliance's environment, and local sanitation regulations.

⚠ WARNING

- Only qualified service technicians should service the appliance.
- To reduce the risk of electric shock, do not touch the control switch or service switch with damp hands
- Before Servicing: Move the power switch to the "OFF" position and unplug the appliance to prevent electric shock or injury by moving parts.

Maintenance Schedule		
Frequency	Area	Task
Bi-Weekly	Air Filter	Inspect. Wash with warm water and neutral cleaner if dirty.
Monthly	External Water Filters	Check for proper pressure and change if necessary.
	Appliance Exterior	Wipe down with a clean, soft cloth. Use a damp cloth containing a neutral cleaner to wipe off oil or dirt build up. Clean any chlorine staining (rust colored spots) using a non-abrasive cleaner.
Every 6 Months	Icemaker and Ice Storage Bin	Clean and sanitize per the cleaning and sanitizing instructions provided in the instruction manual or maintenance label on the appliance.
	Evaporator Condensate Drain Pan and Gear Motor Drain Pan	Wipe down with a clean cloth and warm water. Dilute 0.82 fl. oz. (25 ml) of a 5.25% sodium hypochlorite solution (chlorine bleach) with 1.6 gal. (6.0 l) of warm water. Slowly pour one cup of sanitizing solution into the evaporator condensate drain pan. Be careful not to overflow the pan. This solution will flow down to the gear motor drain pan and out the drain line to sanitize these areas. Repeat with a cup of clean water to rinse.
	Icemaker, Ice Storage Bin, and Drip Tray Drains	Check to make sure they are clear.
Yearly	Inlet Water Valve and Drain Valve	Close the water supply line shut-off valve and drain the water system. Clean the inlet water valve screen and clean and inspect the drain valve.
	Water Hoses	Inspect the water hoses and clean/replace if necessary.
	Condenser	Inspect. Clean if necessary by using a brush or vacuum cleaner.
	Appliance	Inspect for oil spots, loose components, fasteners, and wires.
	Upper Bearing (extruding head)	Check for wear using .02" round stock or pin gauge. Replace both upper bearing and lower bearing if wear exceeds factory recommendations. See "IV.C.1. Upper Bearing Wear Check".
After 3 Years, then Yearly	Upper Bearing (extruding head); Lower Bearing and O-Ring (lower housing); Mechanical Seal; Evaporator Cylinder; Auger	Inspect. Replace both upper bearing and lower bearing if wear exceeds factory recommendations. Replace the mechanical seal if the seal's contact surfaces are worn, cracked, or scratched.

VI. Preparing the Appliance for Periods of Non-Use

NOTICE

When storing the icemaker for an extended time or in sub-freezing temperatures, follow the instructions below to prevent damage.

When the appliance is not used for two or three days under normal conditions, it is sufficient to only move the power switch to the "OFF" position. When storing the appliance for extended time or in sub-freezing temperatures, follow the instructions below.

- 1) Close the icemaker water supply line shut-off valve and open the icemaker water supply line drain valve.
- 2) Remove the louver and air filter, then move the control switch to the "DRAIN" position. Allow the water system to drain for 5 minutes.
- 3) Dispense all of the ice from the storage bin.
- 4) Attach a compressed air or carbon dioxide supply to the icemaker water supply line drain valve.
- 5) While engaging the water dispense switch, blow out the water dispense valve using the compressed air or carbon dioxide supply. After blowing out the water dispense valve, leave the compressed air or carbon dioxide supply flowing. Move the control switch to the "ICE" position to open the inlet water valve and briefly blow out the inlet water valve. After blowing out the inlet water valve, move the control switch to the "OFF" position.
- 6) Close the icemaker water supply line drain valve.
- 7) Move the power switch to the "OFF" position, then unplug the icemaker from the electrical outlet.
- 8) Remove the storage bin cover. Clean the storage bin liner and the storage bin cover using a neutral cleaner. Rinse thoroughly after cleaning. Replace the storage bin cover, front panel, air filter, and louver in their correct positions.

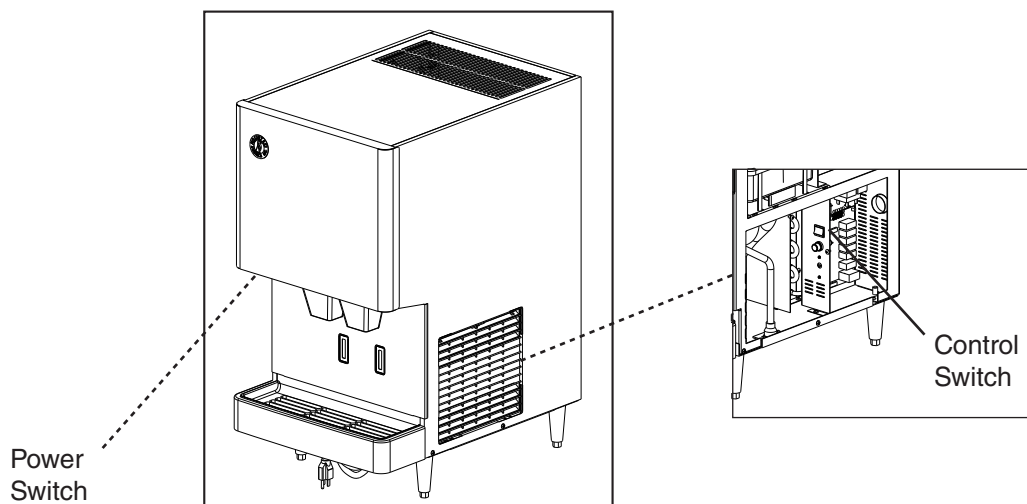

Fig. 4

VII. Disposal

This appliance contains refrigerant and must be disposed of in accordance with applicable national, state, and local codes and regulations. Refrigerant must be recovered by properly certified service personnel.

VIII. Technical Information

We reserve the right to make changes in specifications and design without prior notice.

A. Specification and Performance Data Sheets

Pressure data is recorded at 5 min. into freezing cycle. The data not in bold should be used for reference only.

1. DCM-271BAH

Specification

AC SUPPLY VOLTAGE	115/60/1	
AMPERAGE	8.5 A [AT 104°F (40°C)/WT 80°F(27°C)]	
MINIMUM CIRCUIT AMPACITY	15	
MAXIMUM FUSE SIZE	15	
ELECTRIC & WATER CONSUMPTION	90/70°F	70/50°F
ELECTRIC W (kWH/100 lbs.)	571 (6.90)	537 (5.02)
POTABLE WATER	24 (12.0)	31 (12.0)
	gal./24HR (gal./100 lbs.)	
SHAPE OF ICE	Cubelet	
ICE HARDNESS	Approx. 86%, Ice (32/21 (90/70), Conductivity 200 µs/cm	
APPROXIMATE STORAGE CAPACITY	8.8 lbs.	
BIN CONTROL SYSTEM	Mechanical Bin Control	
REFRIGERANT CHARGE	R404A, 0 lb. 14.8 oz. (420g)	

Performance Data

APPROXIMATE ICE PRODUCTION PER 24 HR.	Ambient Temp. °F (°C)	Water Temp. °F (°C)		
		50 (10)	70 (21)	90 (32)
	70 (21)	257 (117)	255 (116)	242 (110)
	80 (26)	230 (104)	218 (99)	207 (94)
	90 (32)	197 (89)	196 (89)	177 (80)
lbs./day (kg/day)	100 (38)	168 (76)	159 (72)	141 (64)
APPROXIMATE ELECTRIC CONSUMPTION	70 (21)	537 --	542 --	547 --
	80 (26)	552 --	557 --	561 --
	90 (32)	566 --	571 --	582 --
	100 (38)	594 --	605 --	616 --
APPROXIMATE WATER CONSUMPTION PER 24 HR. (TOTAL) gal. / day (l/day)	70 (21)	31 (117)	31 (116)	29 (110)
	80 (26)	28 (104)	26 (99)	25 (94)
	90 (32)	24 (89)	24 (89)	21 (80)
	100 (38)	20 (76)	19 (72)	17 (64)
EVAPORATOR OUTLET TEMP. °F (°C)	70 (21)	18 ((-8))	18 ((-8))	19 ((-7))
	80 (26)	19 ((-7))	19 ((-7))	20 ((-7))
	90 (32)	20 ((-7))	20 ((-6))	22 ((-5))
	100 (38)	24 ((-4))	26 ((-3))	28 ((-2))
HEAD PRESSURE	70 (21)	233 (16.4)	243 (17.1)	254 (17.8)
	80 (26)	264 (18.5)	274 (19.3)	284 (20.0)
	90 (32)	295 (20.7)	305 (21.4)	310 (21.8)
	100 (38)	315 (22.1)	320 (22.5)	325 (22.8)
SUCTION PRESSURE PSIG (kg/cm ² G)	70 (21)	39 (2.7)	39 (2.8)	40 (2.8)
	80 (26)	40 (2.8)	40 (2.8)	40 (2.8)
	90 (32)	41 (2.9)	41 (2.9)	42 (3.0)
	100 (38)	44 (3.1)	45 (3.1)	46 (3.2)
TOTAL HEAT OF REJECTION		3,300 BTU/h (AT 90°F / WT 70°F)		

2. DCM-271BAH-OS

Specifications

AC SUPPLY VOLTAGE	115/60/1	
AMPERAGE	8.5 A [AT 104°F (40°C)/WT 80°F(27°C)]	
MINIMUM CIRCUIT AMPACITY	15	
MAXIMUM FUSE SIZE	15	
ELECTRIC & WATER CONSUMPTION	90/70°F	70/50°F
ELECTRIC W (kWH/100 lbs.)	571 (6.90)	537 (5.02)
POTABLE WATER	23 (12.0)	31 (12.0)
	gal./24HR (gal./100 lbs.)	
SHAPE OF ICE	Cubelet	
ICE HARDNESS	Approx. 86%, Ice (32/21 (90/70), Conductivity 200 µs/cm	
APPROXIMATE STORAGE CAPACITY	8.8 lbs.	
BIN CONTROL SYSTEM	Mechanical Bin Control	
REFRIGERANT CHARGE	R404A, 0 lb. 14.8 oz. (420g)	

Performance Data

APPROXIMATE ICE PRODUCTION PER 24 HR.	Ambient Temp. °F (°C)	Water Temp. °F (°C)		
		50 (10)	70 (21)	90 (32)
lbs./day (kg/day)	70 (21)	257 (117)	255 (115)	242 (110)
	80 (26)	229 (104)	217 (99)	206 (94)
	90 (32)	196 (89)	194 (88)	176 (80)
	100 (38)	167 (76)	159 (72)	141 (64)
APPROXIMATE ELECTRIC CONSUMPTION watts	70 (21)	537 --	542 --	547 --
	80 (26)	552 --	557 --	561 --
	90 (32)	566 --	571 --	582 --
	100 (38)	594 --	605 --	616 --
APPROXIMATE WATER CONSUMPTION PER 24 HR. (TOTAL) gal. / day (l/day)	70 (21)	31 (117)	31 (115)	29 (110)
	80 (26)	27 (104)	26 (99)	25 (94)
	90 (32)	23 (89)	23 (88)	21 (80)
	100 (38)	20 (76)	19 (72)	17 (64)
EVAPORATOR OUTLET TEMP. °F (°C)	70 (21)	18 ((-8))	18 ((-8))	19 ((-7))
	80 (26)	19 ((-7))	19 ((-7))	20 ((-7))
	90 (32)	20 ((-7))	20 ((-6))	22 ((-5))
	100 (38)	24 ((-4))	26 ((-3))	28 ((-2))
HEAD PRESSURE PSIG (kg/cm ² G)	70 (21)	233 (16.4)	243 (17.1)	254 (17.8)
	80 (26)	264 (18.5)	274 (19.3)	284 (20.0)
	90 (32)	295 (20.7)	305 (21.4)	310 (21.8)
	100 (38)	315 (22.1)	320 (22.5)	325 (22.8)
SUCTION PRESSURE PSIG (kg/cm ² G)	70 (21)	39 (2.7)	39 (2.8)	40 (2.8)
	80 (26)	40 (2.8)	40 (2.8)	40 (2.8)
	90 (32)	41 (2.9)	41 (2.9)	42 (3.0)
	100 (38)	44 (3.1)	45 (3.1)	46 (3.2)
TOTAL HEAT OF REJECTION	3,300 BTU/h (AT 90°F / WT 70°F)			

B. Wiring Diagram

SI DIP SWITCH SETTING	No. 1	No. 2	No. 3	No. 4	No. 5	No. 6	No. 7	No. 8	No. 9	No. 10
DCM-271BAH(-OS)	OFF	OFF	OFF	OFF	ON	OFF	OFF	OFF	OFF	OFF

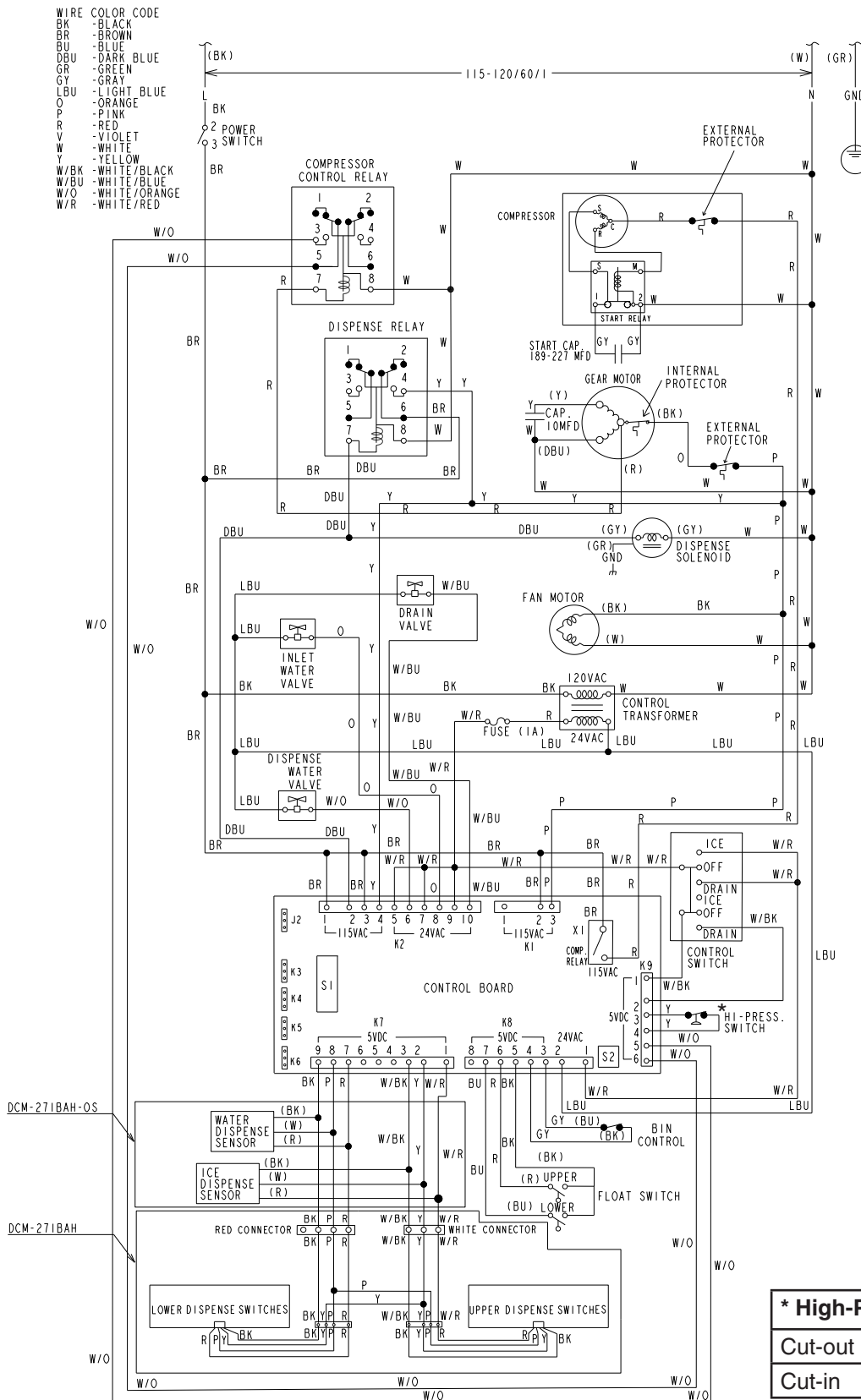

* High-Pressure Switch	
Cut-out	412±22 PSIG
Cut-in	327±22 PSIG