

# Hoshizaki America, Inc.

## Cubelet Icemaker/Dispenser

Models

DCM-300BAH(-OS)



“A Superior Degree  
of Reliability”

[www.hoshizaki.com](http://www.hoshizaki.com)

## SERVICE MANUAL



Number: 73189  
Issued: 1-5-2012

**⚠ WARNING**

Only qualified service technicians should install and service the icemaker. To obtain the name and phone number of your local Hoshizaki Certified Service Representative, visit [www.hoshizaki.com](http://www.hoshizaki.com). No service should be undertaken until the technician has thoroughly read this Service Manual. Failure to service and maintain the icemaker in accordance with this manual will adversely affect safety, performance, component life, and warranty coverage and may result in costly water damage. Proper installation is the responsibility of the installer. Product failure or property damage due to improper installation is not covered under warranty.

Hoshizaki provides this manual primarily to assist qualified service technicians in the service and maintenance of the icemaker.

Should the reader have any questions or concerns which have not been satisfactorily addressed, please call, send an e-mail message, or write to the Hoshizaki Technical Support Department for assistance.

Phone: 1-800-233-1940; (770) 487-2331

Fax: 1-800-843-1056; (770) 487-3360

E-mail: [techsupport@hoshizaki.com](mailto:techsupport@hoshizaki.com)

HOSHIZAKI AMERICA, INC.  
618 Highway 74 South  
Peachtree City, GA 30269  
Attn: Hoshizaki Technical Support Department

Web Site: [www.hoshizaki.com](http://www.hoshizaki.com)

**NOTE:** To expedite assistance, all correspondence/communication **MUST** include the following information:

- Model Number \_\_\_\_\_
- Serial Number \_\_\_\_\_
- Complete and detailed explanation of the problem.

## **IMPORTANT**

This manual should be read carefully before the icemaker is serviced. Read the warnings and guidelines contained in this booklet carefully as they provide essential information for the continued safe use, service, and maintenance of the icemaker. Retain this booklet for any further reference that may be necessary.

## **CONTENTS**

Important Safety Information .....	5
I. Specifications.....	7
A. Icemaker .....	7
II. General Information .....	8
A. Construction.....	8
1. Icemaker .....	8
2. Icemaking Unit.....	9
B. Sequence of Operation .....	10
1. Sequence Cycles and Shutdown .....	10
a) Fill Cycle .....	10
b) Ice Purge Cycle.....	10
c) Freeze Cycle .....	10
d) Drain Cycle .....	10
e) Shutdown.....	10
2. Sequence Flow Chart.....	11
C. Control Board .....	12
1. Control Board Layout .....	13
a) DCM-300BAH.....	13
b) DCM-300BAH-OS.....	14
2. LED Lights and Components.....	15
D. Power Switch, Control Switch, and Dispense Mode Switch .....	15
1. Power Switch.....	15
2. Control Switch.....	16
a) ICE.....	16
b) DRAIN .....	16
3. Dispense Mode Switch .....	16
a) CONTINUOUS.....	16
b) PORTION .....	16
III. Technical Information .....	17
A. Water Circuit and Refrigeration Circuit .....	17
B. Wiring Diagrams.....	18
1. DCM-300BAH .....	18
2. DCM-300BAH-OS .....	19
C. Performance Data .....	20

IV. Service Diagnosis .....	21
A. Ice Production Check .....	21
B. Diagnostic Procedure .....	21
C. Control Board Check .....	26
D. Bin Control Check .....	31
E. Float Switch Check and Cleaning .....	32
1. Float Switch Check .....	32
2. Float Switch Cleaning .....	33
F. Diagnostic Charts .....	34
V. Removal and Replacement of Components .....	38
A. Service for Refrigerant Lines .....	38
1. Refrigerant Recovery .....	39
2. Brazing .....	39
3. Evacuation and Recharge (R-404A) .....	39
B. Important Notes for Component Replacement .....	40
1. Upper Bearing Wear Check .....	42
2. Removal and Replacement of Extruding Head .....	42
3. Removal and Replacement of Auger .....	43
4. Removal and Replacement of Evaporator .....	43
5. Removal and Replacement of Mechanical Seal and Lower Housing .....	45
6. Removal and Replacement of Gear Motor .....	46
7. Dispense Auger and Agitator .....	47
8. Dispense or Agitating Motor .....	47
VI. Cleaning and Maintenance .....	48
A. Cleaning and Sanitizing Instructions .....	49
1. Water System .....	49
a) Cleaning Solution .....	49
b) Cleaning Procedure .....	49
c) Sanitizing Solution .....	50
d) Sanitizing Procedure - Following Cleaning Procedure .....	50
2. Dispense Components .....	51
a) Cleaning Solution .....	51
b) Sanitizing Solution .....	51
c) Cleaning and Sanitizing Procedure .....	51
B. Maintenance .....	53
C. Preparing the Icemaker for Periods of Non-Use .....	54
VII. Disposal .....	55

---

## Important Safety Information

Throughout this manual, notices appear to bring your attention to situations which could result in death, serious injury, damage to the appliance, or damage to property.

**⚠ WARNING** Indicates a hazardous situation which could result in death or serious injury.

**NOTICE** Indicates a situation which could result in damage to the appliance or property.

**IMPORTANT** Indicates important information about the use and care of the appliance.

### **⚠ WARNING**

This icemaker should be destined only to the use for which it has been expressly conceived. Any other use should be considered improper and therefore dangerous. The manufacturer cannot be held responsible for injury or damage resulting from improper, incorrect, and unreasonable use. Failure to service and maintain the appliance in accordance with this manual will adversely affect safety, performance, component life, and warranty coverage and may result in costly water damage.

**To reduce the risk of death, electric shock, serious injury, or fire, follow basic precautions including the following:**

- Only qualified service technicians should install and service this icemaker.
- To reduce the risk of electric shock, do not touch the control switch or power switch with damp hands.
- Before Servicing: To reduce the risk of electric shock, move the control switch to the "OFF" position, then move the power switch to the "OFF" position. Turn off the power supply. Lockout/Tagout to prevent the power supply from being turned back on inadvertently.
- This icemaker must be installed in accordance with applicable national, state, and local codes and regulations. Failure to meet these code requirements could result in death, electric shock, serious injury, fire, or severe damage to equipment.
- This icemaker requires an independent power supply of proper capacity. See the nameplate for electrical specifications. Failure to use an independent power supply of proper capacity can result in a tripped breaker, blown fuse, damage to existing wiring, or component failure. This could lead to heat generation or fire.
- **THIS ICEMAKER MUST BE GROUNDED.** Failure to properly ground the icemaker could result in death or serious injury.
- Do not make any alterations to the icemaker. Alterations could result in electric shock, injury, fire, or damage to the icemaker.
- Do not place fingers or any other objects into the ice discharge opening.
- This appliance is not intended for use by persons (including children) with reduced physical, sensory, or mental capabilities, or lack of experience and knowledge, unless they have been given supervision or instruction concerning use of the appliance by a person responsible for their safety.
- Children should be properly supervised around this appliance.

## ***NOTICE***

- Follow the instructions in this manual carefully to reduce the risk of costly water damage.
- In areas where water damage is a concern, install in a contained area with a floor drain.
- Install the icemaker in a location that stays above freezing. Normal operating ambient temperature must be within 45°F to 100°F (7°C to 38°C).
- Do not leave the icemaker on during extended periods of non-use, extended absences, or in sub-freezing temperatures. To properly prepare the icemaker for these occasions, follow the instructions in "VI.C. Preparing the Icemaker for Periods of Non-Use."
- Keep ventilation openings, in the appliance enclosure or in the built-in structure, clear of obstruction.
- Do not place objects on top of the icemaker.
- The storage bin is for ice use only. Do not store anything else in the storage bin.

# I. Specifications

## A. Ice maker

### 1. DCM-300BAH(-OS)

AC SUPPLY VOLTAGE	115-120/60/1		
COMPRESSOR	115 V	6.0 RLA	29 LRA
GEAR MOTOR	120 V	1.45 FLA	80 W
FAN MOTOR	115 V	0.8 FLA	16 W
AGITATING MOTOR	115 V	0.9 FLA	55 W
DISPENSING MOTOR	115 V	0.9 FLA	55 W
OTHER	120 V	0.2 A	
MAXIMUM FUSE SIZE	20 A		
MAX. HACR BREAKER (USA ONLY)	20 A		
MAX. CIRC. BREAKER (CANADA ONLY)	20 A		
MINIMUM CIRCUIT AMPACITY	20 A		
APPROXIMATE ICE PRODUCTION PER 24 HR.	Ambient Temp.(°F)	WATER TEMP. (°F)	
lbs./day (kg/day)		50	70
Reference without *marks		90	
	70	*321 (146)	307 (139)
	80	277 (125)	263 (119)
	90	237 (107)	*232 (105)
	100	203 (92)	193 (87)
SHAPE OF ICE	Cubelet (Compressed Flake Ice)		
ICE HARDNESS FACTOR	88% (90/70°F, Conductivity 200 µS/cm)		
APPROXIMATE STORAGE CAPACITY	40 lbs.		
ELECTRIC & WATER CONSUMPTION	90/70°F	70/50°F	
ELECTRIC W (kWH/100 lbs.)	661 (6.84)	653 (4.88)	
POTABLE WATER gal./24HR (gal./100 lbs.)	29 (12.5)	40 (12.5)	
EXTERIOR DIMENSIONS (WxDxH)	26"x22-1/2"x40" (661x571x1016)		
EXTERIOR FINISH	Stainless Steel; Galvanized Steel (Rear)		
WEIGHT	Net 215 lbs. (98 kg), Shipping 240 lbs. (109 kg)		
CONNECTIONS - ELECTRIC	Permanent Connection		
- WATER SUPPLY	Inlet 1/2" FPT		
- DRAIN	Drain Pan 3/4" FPT Bin Drain 3/4" FPT		
ICE MAKING SYSTEM	Auger Type		
HARVESTING SYSTEM	Direct Driven Auger (80 W Gear Motor)		
ICE MAKING WATER CONTROL	Float Switch		
COOLING WATER CONTROL	N/A		
BIN CONTROL SYSTEM	Mechanical Bin Control (Proximity Switch)		
COMPRESSOR	Hermetic, Model ASE24C3E-IAA-257		
CONDENSER	Air-Cooled, Fin and Tube Type		
EVAPORATOR	Copper Tube on Cylinder		
REFRIGERANT CONTROL	Thermostatic Expansion Valve		
REFRIGERANT CHARGE	R-404A, 15.9 oz. (450 g)		
DESIGN PRESSURE	High 460 PSIG, Low 290 PSIG		
P.C. BOARD CIRCUIT PROTECTION	High Voltage Cut-Out (Internal)		
COMPRESSOR PROTECTION	Auto-Reset External Protector		
GEAR MOTOR PROTECTION	Manual Reset Circuit Breaker		
REFRIGERANT CIRCUIT PROTECTION	Auto-Reset High-Pressure Switch		
LOW WATER PROTECTION	Float Switch and Timer		
ACCESSORIES - SUPPLIED	Spare Fuse		
- OPTIONAL	Legs		
OPERATING CONDITIONS	VOLTAGE RANGE	104-127VAC	
	AMBIENT TEMP.	45-100°F	
	WATER SUPPLY TEMP.	45-90°F	
	WATER SUPPLY PRESSURE	10-113 PSIG	

Note: We reserve the right to make changes in specifications and design without prior notice.

## II. General Information

### A. Construction

#### 1. Icemaker

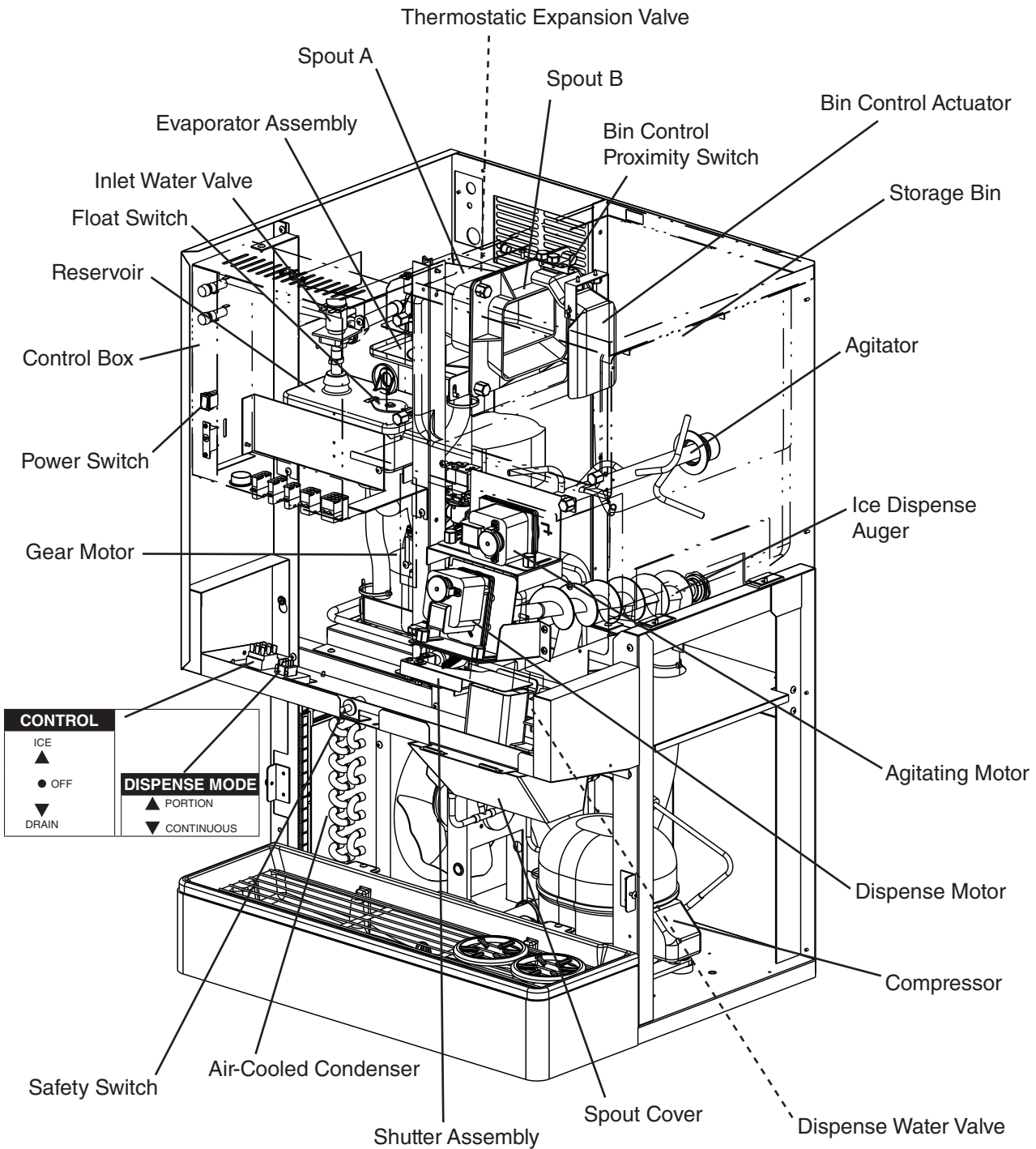

## 2. Icemaking Unit

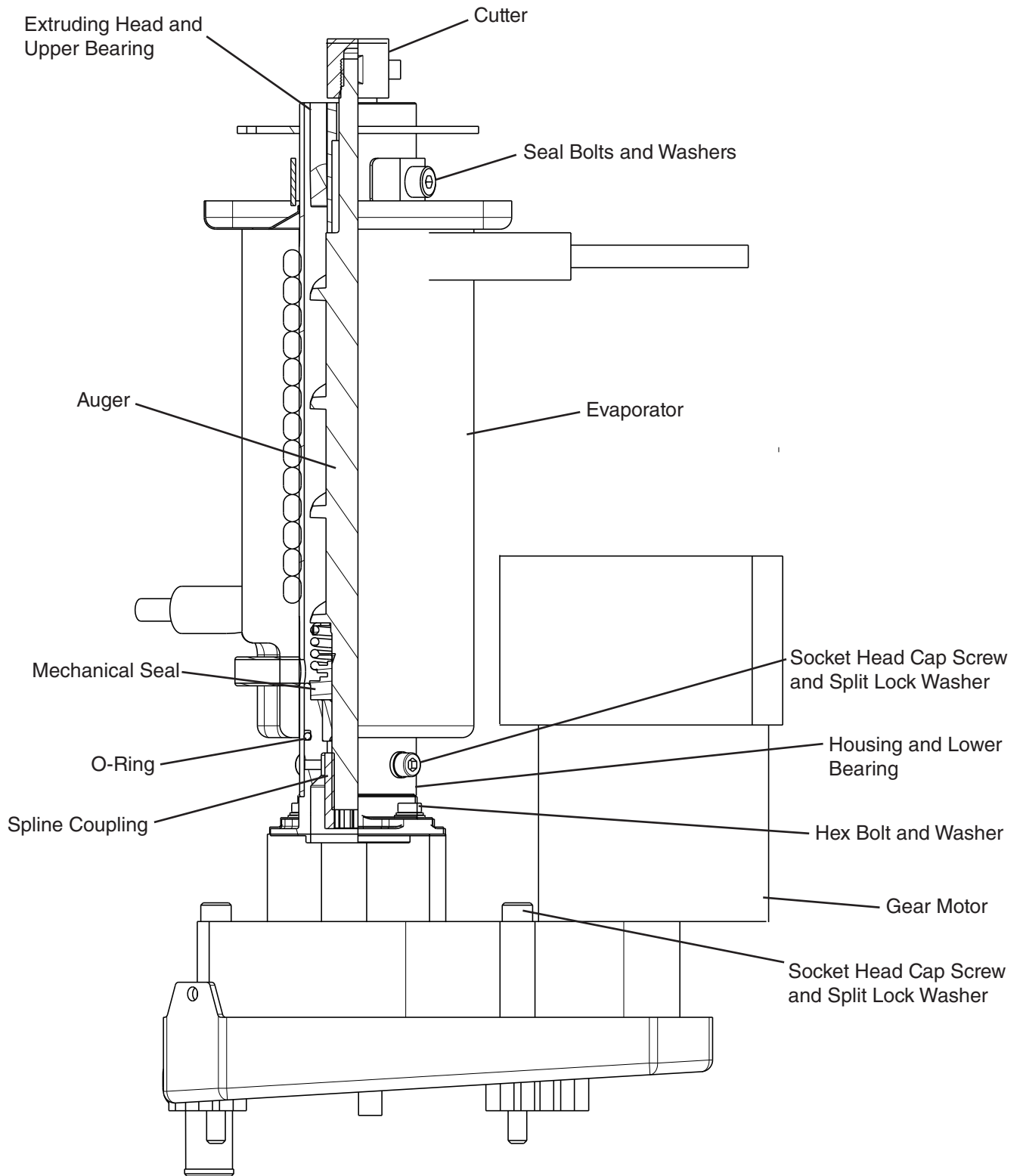

## B. Sequence of Operation

### 1. Sequence Cycles and Shutdown

The steps in the sequence are as outlined below. When power is supplied, power switch is in the "ON" position, safety switch is engaged, and the control switch is in the "ICE" position, CB "POWER" LED turns on. The "POWER" LED indicates control voltage and will remain on unless a control voltage problem occurs. If icemaker does not start, BC actuator and proximity switch may be engaged. Move the dispense mode switch to the "CONTINUOUS" position, then dispense ice to lower the level of ice in the storage bin.

#### a) Fill Cycle

Reservoir is empty. LF/S and UF/S are open. WV energizes and fill cycle starts. LF/S closes. Nothing happens at this time. Reservoir continues to fill until UF/S closes. When UF/S closes, WCR energizes, closing low water safety circuit and de-energizing WV. GM energizes once UF/S closes.

#### b) Ice Purge Cycle

"GM" LED is on. GM energizes. 60-sec. ice purge timer starts. Note: GM cannot energize unless UF/S is closed.

#### c) Freeze Cycle

"COMP" and "GM" LEDs are on. 60-sec. ice purge timer terminates. GM continues. CB confirms GM operation through GMPR terminal #3 (BR wire) and terminal #5 (DBU wire), then Comp and FM energize. Ice production starts 4 to 6 min. after Comp energizes depending on ambient and water temperature conditions. UF/S and LF/S operate WV as needed to continue the icemaking process. **Refill:** As ice is produced the water level in the reservoir drops. UF/S opens. Nothing happens at this time. LF/S opens. FT starts. WCR de-energizes, energizing WV. As water fills the reservoir, LF/S closes. Nothing happens at this time. Water continues to fill and UF/S closes. FT terminates and WCR energizes, closing low water safety circuit and de-energizing WV. If UF/S remains open longer than 90 sec. after LF/S opens (FT exceeded), Comp and FM de-energize. GM de-energizes 60 sec. later. WV remains energized until UF/S closes. The freeze cycle continues until BC shuts the icemaker down, a drain cycle occurs, or power is turned off to the icemaker.

#### d) Drain Cycle

"FLUSH" LED is on. The drain cycle occurs once every 12 hrs. for 20 min. 12-hr. DCT terminates, DVT starts. Comp and FM de-energize. GM de-energizes 60 sec. later. DV energizes. DV remains energized for the remainder of the drain cycle.

#### e) Shutdown

BC activates, 150-sec. shutdown sequence starts. After 90 sec., Comp and FM de-energize, AM energizes for 0.6 seconds, 60 sec. later, GM de-energizes.

Legend: **AM**—agitator motor; **BC**—bin control; **CB**—control board; **Comp**—compressor; **DCT**—drain cycle timer (12-hr. timer); **DV**—drain valve; **DVT**—drain valve timer (20-min. timer); **FM**—fan motor; **FT**—fill timer (90-sec. low water safety); **GM**—gear motor; **GMPR**—gear motor protect relay; **LF/S**—lower float switch; **UF/S**—upper float switch; **WCR**—water control relay; **WV**—inlet water valve

## 2. Sequence Flow Chart

### "DCM-PB" and "DCM-OS" Control Board Sequence Flow Chart DCM-300BAH(-OS)

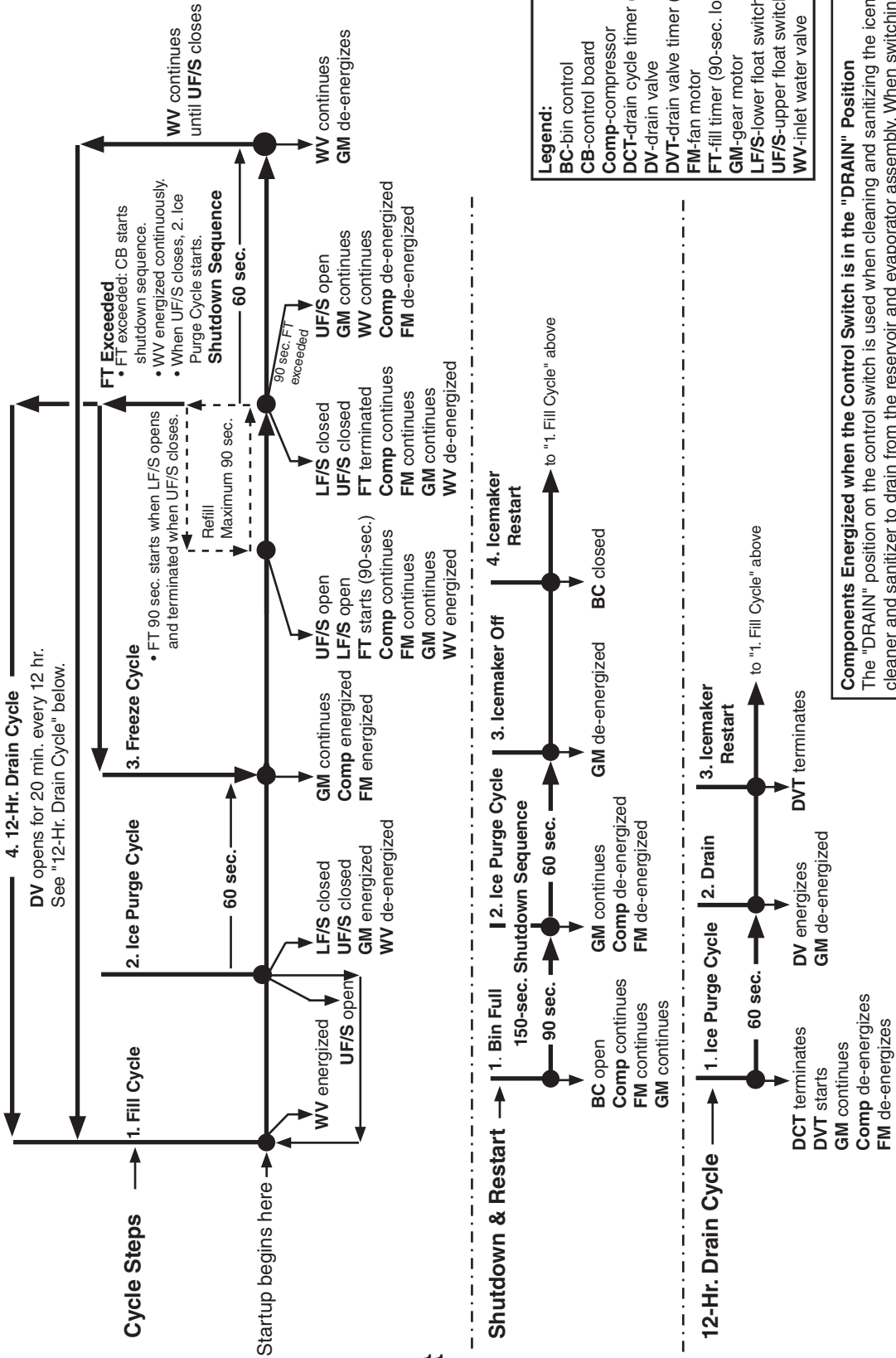

## C. Control Board

- A Hoshizaki exclusive control board is employed in Hoshizaki icemakers.
- All models are pre-tested and factory adjusted.
- For a control board check procedure, see "IV.C. Control Board Check Procedure."

### ***NOTICE***

- The control board is fragile; handle very carefully.
- The control board contains integrated circuits, which are susceptible to failure due to static discharge. It is especially important to touch the metal part of the icemaker before handling or replacing the control board.
- Do not touch the electronic devices on the control board or the back of the control board.
- Do not change wiring and connections. Do not misconnect terminals.
- Do not short out power supply to test for voltage.
- Always replace the whole control board assembly if it goes bad.



b) DCM-300BAH-OS

"DCM-OS" Opti-Serve Model Control Board

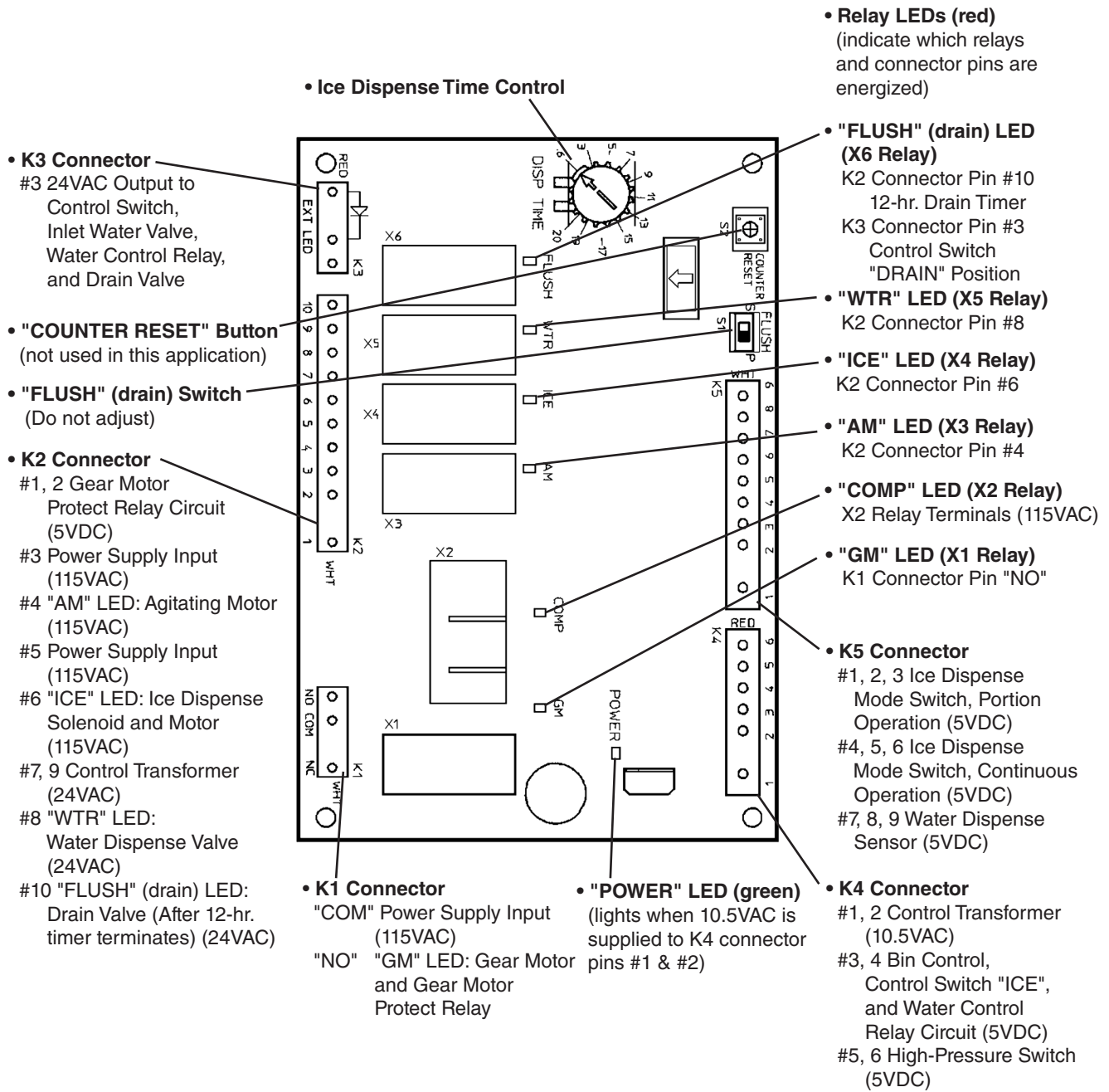

Control Board	
Part Number	2A2649-01

## 2. LED Lights and Components

The "POWER" LED indicates control voltage and will remain on unless a control voltage problem occurs. For further details, see "II.B. Sequence of Operation."

Icemaking				
Cycle (Relay)	LED	Energized Components	Time LEDs are On	Frequency LEDs are On
Fill	-	WV	N/A	N/A
Ice Purge (X1)	GM	GM	60 sec.	N/A
Freeze (X1, X2)	GM, COMP	GM, Comp, FM	N/A	N/A
Drain (X5 push button) (X6 OS)	FLUSH (drain)	DV	20 min.	Every 12 hr.

Ice/Water Dispense				
Relay	LED	Energized Component	Time LEDs are On	Frequency LEDs are On
Ice Dispense (X4)	Push Button DM	DM, DS	60 sec. max.	N/A
	Opti-Serve ICE			
Agitating Motor (X3)	AM	AM	0.6 sec.	Every 12 sec. of accumulative dispense time
Water Dispense (X5) (Opti-Serve Only)	WTR	DispWV	N/A	N/A

Legend: **AM**—agitating motor; **Comp**—compressor; **DispWV**—dispense water valve ("WTR" LED on DCM-300BAH-OS); **DM**—dispense motor; **DS**—dispense solenoid; **DV**—drain valve; **FM**—fan motor; **GM**—gear motor; **WV**—inlet water valve

## D. Power Switch, Control Switch, and Dispense Mode Switch

The power switch, control switch, and dispense mode switch are used to control the operation of this icemaker.

### 1. Power Switch

The power switch has 2 positions, "OFF" and "ON." **WARNING! 115VAC power supply is present on control board K1 connector pin "COM" and the control board X2 relay (gear motor) (BR wire) when the power switch is in the "OFF" position.**

When the power switch is in the "OFF" position, no power is supplied to the control transformer or control board K2 connector pin #3 and the K2 connector pin #5.

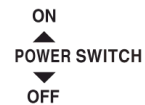

When the power switch is in the "ON" position, 115VAC power supply is directed to the control transformer and control board K2 connector pin #3 (BK wire) and pin #5 (BK wire). The control board then directs 24VAC from the K3 connector pin #3 (DBU wire) to one side of the double-pole double-throw control switch, at the same time, the control board directs 5VDC from the K4 connector pin #4 (V wire) to the other side of the control switch.

## 2. Control Switch

The control switch is a double-pole double-throw switch with 3 positions, "ICE," "OFF," and "DRAIN."

### a) ICE

When the control switch is in the "ICE" position, the control switch directs 5VDC from control board K4 connector pin #3 to control board K4 connector pin #4. When the control board receives 5VDC on K4 connector pin #4, the icemaking process starts.

### b) DRAIN

When the control switch is in the "DRAIN" position, the control switch directs 24VAC power supply to the drain valve and breaks the 5VDC to the control board K4 connector pin #4.

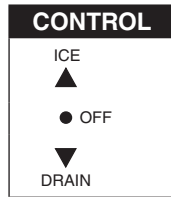

## 3. Dispense Mode Switch

The dispense mode switch has 2 positions, "CONTINUOUS" and "PORTION."

### a) CONTINUOUS

When the dispense mode switch is in the "CONTINUOUS" position, ice dispenses continuously for a maximum of 60 seconds per activation.

### b) PORTION

When the dispense mode switch is in the "PORTION" position, ice dispenses for the amount of time determined by the ice dispense time setting.



The ice dispense time control is located on the control board. The dial indicates dispense time in seconds and is adjustable between 0.6 and 20 seconds. When shipped, the ice dispense time control is set to the minimum dispense time of 0.6 sec. (approximately 0.72 oz.).

Ice Dispense Time Control

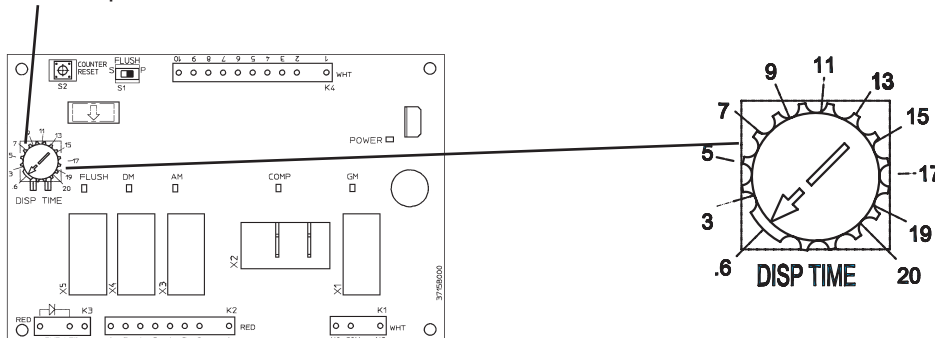

### III. Technical Information

#### A. Water Circuit and Refrigeration Circuit

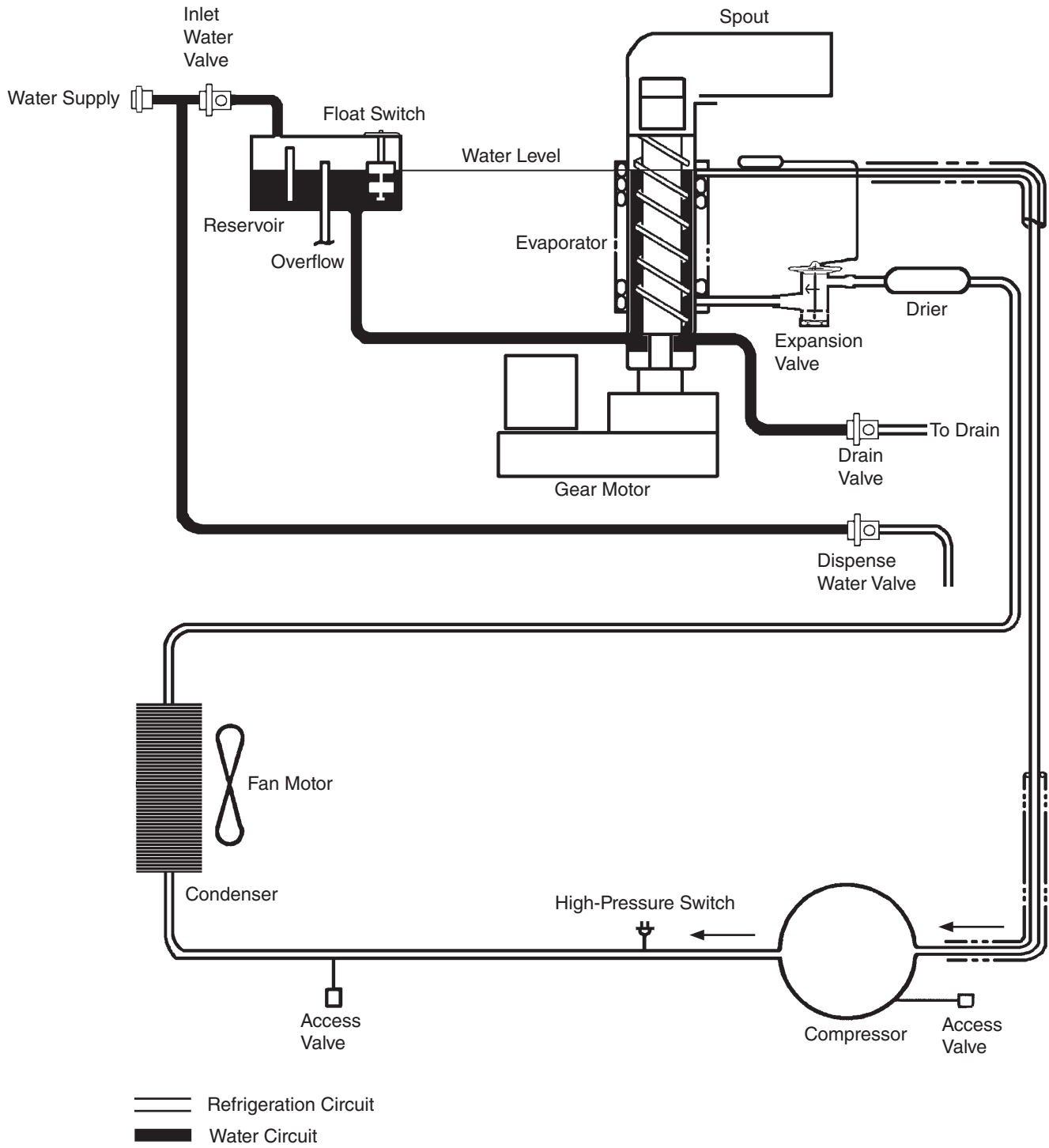

# B. Wiring Diagrams

## 1. DCM-300BAH

WIRE COLOR CODE

- BK -BLACK
- BR -BROWN
- BU -BLUE
- DBU -DARK BLUE
- GY -GRAY
- LBU -LIGHT BLUE
- O -ORANGE
- P -PINK
- R -RED
- V -VIOLET
- W -WHITE
- Y -YELLOW

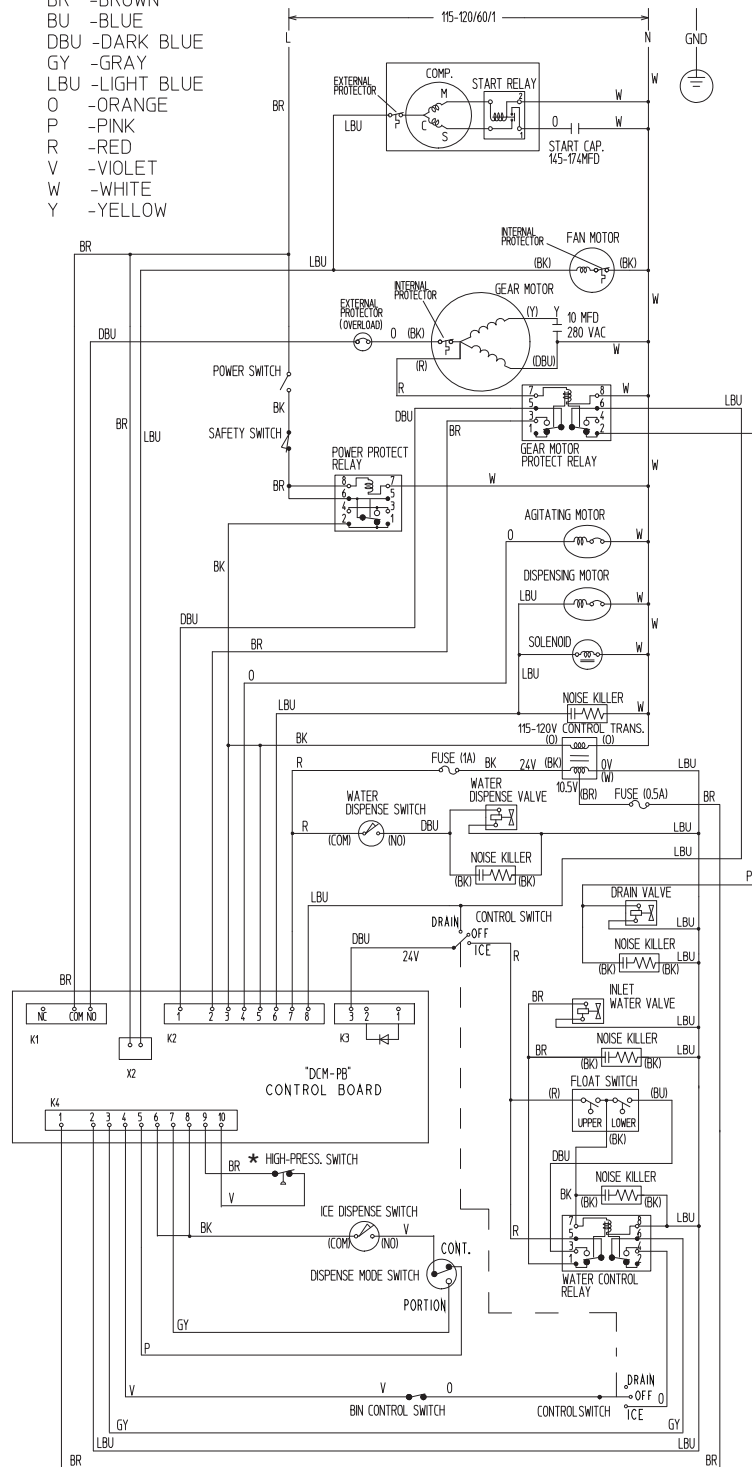

* High-Pressure Switch	
Cut-out	412± <sup>21</sup> <sub>0</sub> PSIG
Cut-in	327±21 PSIG

## 2. DCM-300BAH-OS

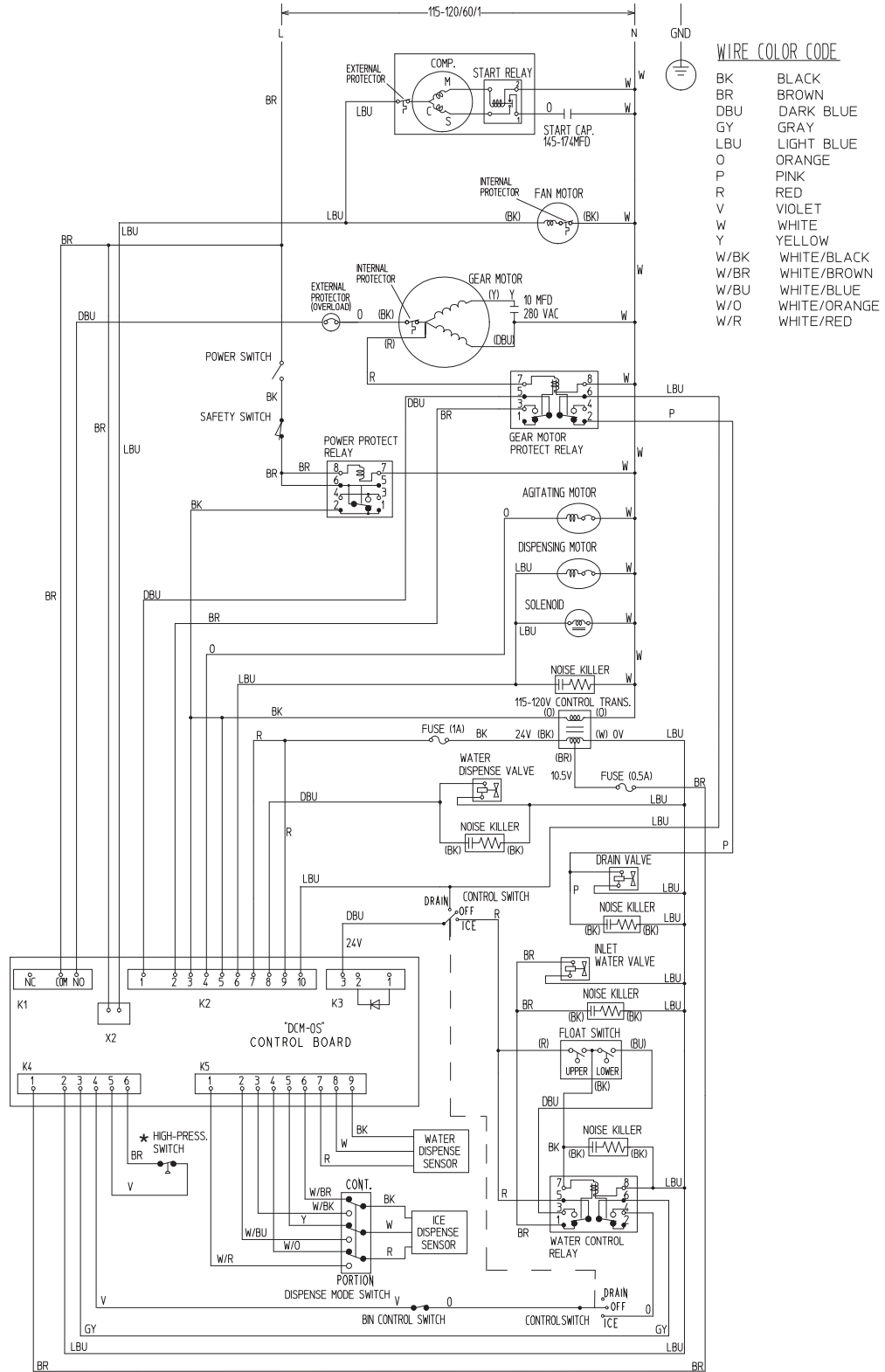

* High-Pressure Switch	
Cut-out	412± <sup>21</sup> <sub>0</sub> PSIG
Cut-in	327±21 PSIG

## C. Performance Data

### 1. DCM-300BAH(-OS)

APPROXIMATE ICE PRODUCTION PER 24 HR.	Ambient Temp. (°F)	Water Temp. (°F)					
		50		70		90	
	70	<b>321</b>	<b>146</b>	307	<u>139</u>	291	<u>132</u>
	80	277	<u>125</u>	263	<u>119</u>	249	<u>113</u>
	90	237	<u>107</u>	<b>232</b>	<b>105</b>	214	<u>97</u>
lbs./day <u>kg/day</u>	100	203	<u>92</u>	193	<u>87</u>	<b>181</b>	<b>82</b>
APPROXIMATE ELECTRIC CONSUMPTION	70	<b>653</b>	--	654	--	655	--
	80	656	--	658	--	659	--
	90	660	--	<b>661</b>	--	666	--
	watts	100	671	--	675	--	<b>680</b>
APPROXIMATE WATER CONSUMPTION PER 24 HR.	70	<b>40</b>	<b>152</b>	38	<u>145</u>	36	<u>138</u>
	80	35	<u>131</u>	33	<u>124</u>	31	<u>118</u>
	90	30	<u>112</u>	<b>29</b>	<b>110</b>	27	<u>101</u>
	gal./day <u>l/day</u>	100	25	<u>96</u>	24	<u>91</u>	<b>23</b>
EVAPORATOR OUTLET TEMP	70	<b>19</b>	<u>-7</u>	19	<u>-7</u>	19	<u>-7</u>
	80	19	<u>-7</u>	23	<u>-5</u>	23	<u>-5</u>
	90	23	<u>-5</u>	<b>23</b>	<b>-5</b>	25	<u>-4</u>
	°F <u>°C</u>	100	25	<u>-4</u>	25	<u>-4</u>	<b>25</b>
HEAD PRESSURE	70	<b>200</b>	<b>14.1</b>	200	<u>14.1</u>	200	<u>14.1</u>
	80	237	<u>16.6</u>	237	<u>16.6</u>	237	<u>16.6</u>
	90	273	<u>19.2</u>	<b>273</b>	<b>19.2</b>	273	<u>19.2</u>
	PSIG <u>kg/cm²G</u>	100	315	<u>22.1</u>	315	<u>22.1</u>	<b>315</b>
SUCTION PRESSURE	70	<b>37</b>	<b>2.6</b>	37	<u>2.6</u>	37	<u>2.6</u>
	80	39	<u>2.7</u>	39	<u>2.7</u>	39	<u>2.7</u>
	90	41	<u>2.9</u>	<b>41</b>	<b>2.9</b>	41	<u>2.9</u>
	PSIG <u>kg/cm²G</u>	100	45	<u>3.2</u>	45	<u>3.2</u>	<b>45</b>
TOTAL HEAT OF REJECTION 3,500 BTU/h (AT 90°F /WT 70°F)							

Note:

1. Pressure data is recorded at 5 minutes into freezing cycle. The data not in **bold** should be used for reference only.
2. We reserve the right to make changes in specifications and design without prior notice.

---

## IV. Service Diagnosis

### WARNING

- This icemaker should be diagnosed and repaired only by qualified service personnel to reduce the risk of death, electric shock, serious injury, or fire.
- Risk of electric shock. Use extreme caution and exercise safe electrical practices.
- Moving parts (e.g., fan blade) can crush and cut. Keep hands clear.
- **CHOKING HAZARD:** Ensure all components, fasteners, and thumbscrews are securely in place after the icemaker is serviced. Make sure that none have fallen into the storage bin.
- Make sure all food zones in the icemaker and storage bin are clean after the icemaker is serviced. For cleaning procedures, see "VI. Cleaning and Maintenance."

### A. Ice Production Check

To check production, prepare a bucket or pan to catch the ice and a set of scales to weigh the ice. After the icemaker has operated for 10 to 20 minutes, catch the ice production for 10 minutes. Weigh the ice to establish the batch weight. Multiply the batch weight by 144 for the total production in 24 hr.

### B. Diagnostic Procedure

This diagnostic procedure is a sequence check that allows you to diagnose the electrical system and components. Before proceeding, check for correct installation, adequate water pressure (10 to 113 PSIG), and proper voltage per unit nameplate. Check that the 24VAC 1A fuse and the 10.5VAC 0.5A fuse are good. When checking high-voltage (115VAC), always choose a neutral (W wire) to establish a good neutral connection. When checking low-voltage (24VAC and 10.5VAC), always choose a neutral (LBU wire) from CT to establish a good neutral connection. **WARNING! LBU wires are used in both high-voltage and low-voltage applications. When checking low-voltage (24VAC and 10.5VAC) confirm that the neutral (LBU wire) being used is the LBU wire from CT, not the 115VAC power LBU wire used for Comp/FM operation or the 24VAC LBU wire on the control switch to GMPR (DV operation).**

When checking DC-voltage (5VDC), use CB K3 connector pin #1 for DC ground (GND). CB "POWER" LED remains on unless power supply is interrupted. **IMPORTANT! Icemaker will not start unless the front panel safety switch is engaged.**

- 1) Turn on the power supply. Remove the front panel. Move the power switch to the "ON" position, then move the control switch to the "DRAIN" position. Engage the safety switch.
- 2) Allow the water system to drain for 5 minutes. If water does not drain from the icemaker, see step 12 Drain Cycle below.
- 3) Disengage the safety switch, then move the control switch to the "OFF" position.
- 4) Move the power switch to the "OFF" position.
- 5) Remove the control box cover.
- 6) Engage the safety switch.

- 7) **Startup** – Move the power switch to the "ON" position, then move the control switch to the "ICE" position to start the automatic icemaking process. **Diagnosis:** Check that CB "POWER" LED is on. If not, check for proper power supply voltage (115VAC) input to CT. If 115VAC is not present, check the breaker, power switch, and front panel safety switch. Next, check that the power protect relay is de-energized and contacts between terminals #6 (BR wire) and #2 (BK wire) are closed. Check for proper control voltage (10.5VAC) output from CT to CB K4 connector pin #1 (BR wire) to CB K4 connector pin #2 (LBU wire). If 10.5VAC is not present and 10.5VAC 0.5A fuse is good, replace CT. If 10.5VAC is present and "POWER" LED is off, replace CB.
- 8) **Fill Cycle** – Reservoir is empty. LF/S and UF/S are open. WV energizes and fill cycle starts. LF/S closes. Nothing happens at this time. Reservoir continues to fill. UF/S closes. WCR energizes, closing low water safety circuit (WCR terminals #6 (GY wire) and #4 (O wire)) and de-energizing WV. GM energizes. **Diagnosis:** If reservoir is empty and WV is off, confirm LF/S status. See "IV.E. Float Switch Check and Cleaning." Check that WV energizes and water fills the reservoir. If not, check that the water supply line shut-off valve is open, possible clogged water filters, and clogged WV screen. If LF/S is open and WV is off, check for 24VAC at CB K2 connector pin #7 (R wire) to CB K2 connector pin #8 (LBU wire). If 24VAC is not present and the 24VAC 1A fuse is good, replace CT. If 24VAC is present, check for 24VAC at K3 connector pin #3 (DBU wire) to a neutral (LBU wire). If 24VAC is not present, replace CB. If 24VAC is present, check for 24VAC at the control switch (R wire) to a neutral (LBU wire). If 24VAC is not present, make sure the control switch is in the "ICE" position. Replace the control switch if defective. If 24VAC is present, check for 24VAC at WCR terminal #1 (BR wire) to WCR terminal #5 (R wire). If 24VAC is present, WCR is energized or defective. If energized, check that UF/S is open. See "IV.E. Float Switch Check and Cleaning." If not energized, replace WCR. If 24VAC is not present, check WCR terminal #1 (BR wire) to a neutral (LBU wire). If 24VAC is present, check WV solenoid wire connections and continuity. If WV is energized and refill exceeds FT with no water in the reservoir, check for DV leaking. If reservoir is full and overflowing check for open UF/S. See "IV.E. Float Switch Check and Cleaning." If UF/S is closed, check that WCR energizes, de-energizing WV. If not, check for 24VAC at WCR terminal #7 (BK wire) to WCR terminal #8 (LBU wire). If 24VAC is present and WV does not de-energize, replace WCR. If WV de-energizes and water continues to fill the reservoir, replace WV.

- 9) **Ice Purge Cycle – "GM" LED is on.** GM and GMPR energize. 60-sec. ice purge timer starts. GM runs for 60 sec. to clear any ice from the evaporator. Note: GM cannot energize unless UF/S is closed, WCR is energized, and WCR terminals #4 (O wire) and #6 (GY wire) are closed. **Diagnosis:** If "GM" LED is off, check control switch and BC continuity. If either are open, CB "GM" LED will not turn on. If both are closed and CB "GM" LED does not turn on, replace CB. If "GM" LED turns on and GM does not energize, check for 115VAC at CB K1 connector NO pin (DBU wire) to a neutral (W wire). If 115VAC is not present, replace CB. If 115VAC is present, check GM external protector (overload), GM windings continuity, and GM capacitor. If GM external protector or GM internal protector is open, allow to cool and reset. If reset does not occur, replace as needed. If GM winding is open, replace GM. If GM energizes, but auger does not turn, check coupling between auger and GM. If Comp energizes at the same time GM energizes, check CB. See "IV.C. Control Board Check."
- 10) **Freeze Cycle – "COMP" and "GM" LEDs are on.** 60-sec. ice purge timer terminates. GM continues. CB confirms GM operation through GMPR terminal #3 (BR wire) and terminal #5 (DBU wire). Comp and FM energize. Ice production begins 4 to 6 min. after Comp and FM energize depending on ambient and water temperature conditions. **Diagnosis:** 60 sec. after GM energizes, confirm Comp LED turns on and Comp and FM energize. If not, check that GMPR is energized (115VAC). Next, check continuity between GMPR terminal #3 (BR wire) and terminal #5 (DBU wire). If open, GMPR is de-energized or contacts are stuck open. If closed, and "COMP" LED, Comp, and FM do not energize, replace CB. If "COMP" LED turns on and Comp and FM do not energize, confirm 115VAC at CB X2 relay (BR wire) to a neutral (W wire). If 115VAC is not present, check connections. If 115VAC is present, confirm 115VAC at CB X2 relay light blue (LBU wire) to a neutral (W wire). If 115VAC is not present and "COMP" LED is on, replace CB. If 115VAC is present, check Comp external protector (overload), allow to cool and reset. If reset does not occur, replace as needed. Check Comp motor windings continuity and Comp capacitor. Check FM for binding and FM winding continuity.
- 11) **Refill /Low Water Safety** – As ice is produced the water level in the reservoir drops. UF/S opens. Nothing happens at this time. LF/S opens. FT starts. WCR de-energizes, energizing WV. Comp, FM and GM continue. As water fills the reservoir, LF/S closes. Nothing happens at this time. UF/S closes. FT terminates. WCR energizes, closing low water safety circuit and de-energizing WV. This continues until BC shuts the icemaker down, a drain cycle occurs, or power is turned off to the icemaker. **Diagnosis:** Confirm that the water level has dropped and UF/S and LF/S are open. See "IV.E. Float Switch Check and Cleaning." Check that the reservoir fills. If not, check for water supply line shut-off valve closed, clogged water filters, dirty or sticking F/S, clogged WV screen, defective WCR, defective WV coil, and DV leaking by. For further information, see "IV.B.8) Fill Cycle." If UF/S remains open longer than 90 sec. after LF/S opens (FT exceeded), Comp and FM de-energize. GM de-energizes 60 sec. later. WV continues until UF/S closes.

12) **Drain Cycle – "FLUSH" (drain) LED is on.** The icemaker drains the evaporator and reservoir once every 12 hr. A manual drain is provided when cleaning the icemaker by moving the control switch from the "ICE" position to the "DRAIN" position.

**a) Automatic Drain Cycle:** A drain cycle occurs once every 12 hr. for 20 min.

DCT terminates and DVT starts. If the icemaker is not running when DCT terminates, DV energizes immediately. If the icemaker is running when DCT terminates, Comp and FM de-energize. GM de-energizes 60 sec. later, then DV energizes. Once DVT terminates, DCT resets and DV de-energizes. Fill cycle starts. DCT resets every time the power supply is turned off and on again. **Diagnosis:** Once GM de-energizes, DV energizes. If not, check for 24VAC at the control switch (LBU wire) to a neutral (LBU wire). If 24VAC is not present, replace CB. If 24VAC is present, check for 24VAC at GMPR terminal #2 (P wire) to a neutral (LBU wire). If 24VAC is not present, GMPR is energized or defective. If GMPR is energized, confirm GM is off. If not, DCT has not terminated or 60-sec. shutdown sequence is not complete. If 60-sec. shutdown is complete and GM is still energized, replace CB. If 24VAC is present, check for 24VAC on DV. If 24VAC is present and DV does not energize, check DV solenoid continuity.

**b1) Manual Drain:** 150-sec. shutdown sequence: Move the control switch to the "DRAIN" position. The 150-sec. shutdown sequence starts. 90 sec. after moving the control switch to the "DRAIN" position, Comp and FM de-energize, 60 sec. later GM de-energizes and DV energizes. DV continues until the control switch is moved to the "OFF" or "ICE" position or power is turned off. **Diagnosis:** Once GM de-energizes, DV energizes. If not, check for 24VAC at CB K3 connector pin #3 (DBU wire) to a neutral (LBU wire). If 24VAC is not present, confirm 24VAC power supply to CB K2 connector pin #7 (R wire) on push button model and pin #9 (R wire) on Opti-Serve model to a neutral (LBU wire). If 24VAC is present on CB K2 pin #7 (push button model) or pin #9 (Opti-Serve model) and not on CB K3 connector pin #3 (DBU wire), replace CB. If 24VAC is present at CB K3 connector pin #3 (DBU wire), check for 24VAC at control switch (LBU wire) to a neutral (LBU wire). If 24VAC is not present, check continuity of the control switch. Replace the control switch if defective. If 24VAC is not present, GMPR is energized or defective. If 24VAC is present, check for 24VAC at GMPR terminal #2 (P wire) to a neutral (LBU wire). If 24VAC is not present, check GMPR continuity between terminals #2 (P wire) and #6 (LBU wire). If open, replace GMPR. Next, check for 24VAC at DV. If 24VAC is present and DV does not energize, check DV solenoid continuity.

**b2) Manual Drain:** 150-sec. shutdown sequence bypass: To bypass the 150-sec. shutdown sequence, remove the front panel, then move the power switch to the "OFF" position. Next, move the control switch to the "DRAIN" position, then move the power switch to the "ON" position. DV energizes. **IMPORTANT! Drain valve will not energize unless the front panel safety switch is engaged.**

**Diagnosis:** If DV does not energize, check for 24VAC at CB K3 connector pin #3 (DBU wire) to a neutral (LBU wire). If 24VAC is not present, confirm 24VAC power supply to CB K2 connector pin #7 (R wire) on push button model and pin #9 (R wire) on Opti-Serve model to a neutral (LBU wire). If 24VAC is present at CB K2 pin #7 (push button model) or pin #9 (Opti-Serve model) and not on CB K3 connector pin #3 (DBU wire), replace CB. If 24VAC is present at CB K3 connector pin #3 (DBU wire), check for 24VAC at control switch (LBU wire) to a neutral (LBU wire). If 24VAC is not present, check continuity of the control switch. Replace the control switch

if defective. If 24VAC is present, check for 24VAC at GMPR terminal #2 (P wire) to a neutral (LBU wire). If 24VAC is not present, check GMPR continuity between terminals #2 (P wire) and #6 (LBU wire). If open, replace GMPR. Next, check for 24VAC at DV. If 24VAC is present and DV does not energize, check DV solenoid continuity.

- 13) **Shutdown** – Bin fills with ice and activates BC actuator paddle. 150-sec. shutdown sequence begins. 90 sec. after BC opens, Comp and FM de-energize, AM energizes for 0.6 sec., 60 sec. later, GM de-energizes. **Diagnosis:** Check that BC actuator paddle is activated and not sticking. Check BC proximity switch continuity to confirm BC proximity switch is open. If BC actuator is engaged and BC proximity switch is closed, replace BC proximity switch. If BC proximity switch is open and Comp, FM, and GM do not de-energize, replace CB. See "IV.C. Control Board Check Procedure."

Legend: **AM**–agitator motor; **BC**–bin control; **CB**–control board; **Comp**–compressor; **CT**–control transformer; **DCT**–drain cycle timer (12-hr. timer); **DV**–drain valve; **DVT**–drain valve timer (20-min. timer); **FM**–fan motor; **FT**–fill timer (90-sec. low water safety); **GM**–gear motor; **GMPR**–gear motor protect relay; **LF/S**–lower float switch; **UF/S**–upper float switch; **WCR**–water control relay; **WV**–inlet water valve

## C. Control Board Check

Before replacing CB that does not show a visible defect and that you suspect is bad, conduct the following CB check. This procedure will help you verify your diagnosis. Before proceeding, check for proper voltage per unit nameplate. Check that the 24VAC 1A fuse, 10.5VAC 0.5A CT fuse are good, and the 115VAC GM external protector is not tripped. When checking high-voltage (115VAC), always choose a neutral (W wire) to establish a good neutral connection. When checking low-voltage (24VAC and 10.5VAC), always choose a neutral (LBU wire) from CT to establish a good neutral connection.

**WARNING! LBU wires are used in both high-voltage and low-voltage applications. When checking low-voltage (24VAC and 10.5VAC) confirm that the neutral (LBU wire) being used is the CB K4 connector pin #2 (LBU wire) from the CT. Not the LBU wire used for GM operation (115VAC) or DV (24VAC power supply) operation.**

When checking CB DC-voltage (5VDC), use CB K3 connector pin #1 for DC ground (GND). The "POWER" LED remains on unless power supply is interrupted.

**IMPORTANT! Icemaker will not start unless the front panel safety switch is engaged.**

- 1) Remove the front panel and control box cover.
- 2) Turn on the power supply. Move the power switch to the "ON" position.
- 3) **Startup – "POWER" LED on:** Move the control switch to the "ICE" position. Engage the safety switch, the "POWER" LED turns on. **IMPORTANT! CB "POWER" LED will not come on unless the front panel safety switch is engaged. Diagnosis:** If "POWER" LED does not turn on, check for 10.5VAC at CB K4 connector pin #1 (BR wire) to pin #2 (LBU wire). If 10.5VAC is present, and the "POWER" LED is off, replace CB. If 10.5VAC is not present, see "IV.B.7) Startup."

### 4) 5VDC Output Checks:

There are 6 CB circuits utilizing 5VDC: high-pressure switch, icemaking control circuit, freeze protect circuit, ice dispense switch, dispense mode switch ("CONTINUOUS" or "PORTION"), and the water dispense switch/water dispense sensor (Opti-Serve model only). The high-pressure switch and the icemaking control circuit can prevent CB from starting the icemaking process.

- High-Pressure Switch: CB must have continuity through HPS to start the icemaking process. HPS is a normally closed switch. Before proceeding to CB check, confirm HPS condition. Turn off the power supply, then remove HPS wires and check continuity across HPS. If open, allow to reset. If HPS does not reset, see "IV.B.10) Freeze Cycle."
  - a) Push Button Model: If HPS closed, check for 5VDC from CB K4 connector pin #10 (V wire) to CB K3 connector pin #1 (open). If 5VDC is not present and "POWER" LED is on, replace CB. If 5VDC is present, check for 5VDC from CB K4 connector pin #9 (BR wire) to CB K3 connector pin #1 (open). If 5VDC is not present, replace HPS or HPS wiring. If 5VDC is present, HPS circuit is good and WV should energize and start filling the reservoir. If not, see "IV.C.5) Fill Cycle."
  - b) Opti-Serve Model: If HPS closed, check for 5VDC from CB K4 connector pin #6 (BR wire) to CB K3 connector pin #1 (open). If 5VDC is not present and "POWER" LED is on, replace CB. If 5VDC is present, check for 5VDC from CB K4 connector pin #5 (V wire) to CB K3 connector pin #1 (open). If 5VDC is not present, replace HPS or HPS wiring. If 5VDC is present, HPS circuit is good and WV should energize and start filling the reservoir. If not, see "IV.C.5) Fill Cycle."

- **Icemaking Control Circuit:** The icemaking control circuit consists of WCR, CS, and BC. The icemaking control circuit activates once UF/S closes. Once CB reads a closed circuit through WCR, CS, and BC, CB then starts the 60-sec. ice purge cycle (GM operation). Once UF/S closes, WCR energizes, closing contacts between WCR terminals #4 (GY wire) and #6 (O wire). CS must be in the "ICE" position (O wires). BC proximity switch must be closed (O and V wires) to complete the icemaking circuit between CB K4 connector pin #3 (GY wire) and #4 (V wire). **Diagnosis:** Confirm UF/S has closed and WCR energizes. Next, check for 5VDC from CB K4 connector pin #3 (GY wire) and CB K4 connector pin #4 (V wire) to CB K3 connector pin #1 (open). If 5VDC is not present on CB K4 connector pin #3 (GY wire) or pin #4 (V wire), replace CB. If 5VDC is present on one and not the other, check continuity on WCR terminals #4 and #6, CS, and BC.
- **Freeze Protect Circuit (GMPR):** Once 60-sec. ice purge cycle starts, GM and GMPR energize, closing GMPR pins #3 (BR wire) and #5 (DBU wire). CB circuit K2 connector pin #1 (DBU wire) and #2 (BR wire) is now closed. Once 60-sec. ice purge timer terminates, CB energizes Comp. If this circuit is open, Comp cannot energize. **Diagnosis:** Check for 5VDC at CB K2 connector pin #1 (DBU wire) and CB K2 connector pin #2 (BR wire) to CB K3 connector pin #1 (open). If 5VDC is not present on either pin, replace CB. If 5VDC is present on one and not the other, confirm GMPR is energized and terminals #3 and #5 contacts are closed. If 5VDC is present on both, once 60-sec. ice purge timer terminates, Comp and FM start. If not, replace CB.
- **Ice Dispense Controls:**
  - a) **Push Button Model – "DM" and "AM" LEDs are on:** Ice Dispense Switch, Dispense Mode Switch ("CONTINUOUS" or "PORTION")—When the ice dispense mode switch is pressed, "DM" LED is on. Circuit is closed between CB K4 connector pin #6 (BK wire) and #8 (BK wire) to #7 (GY wire) or #5 (P wire) depending on dispense mode switch ("CONTINUOUS" or "PORTION"). **Diagnosis:** Check for 5VDC from CB K4 connector pin #6 (BK wire) or pin #8 (BK wire) to CB K3 connector pin #1 (open). If 5VDC is not present, replace CB. If 5VDC is present, press and hold the ice dispense button. DS and DM should energize. If not, check for 115VAC at CB K2 connector pin #6 (LBU wire) to a neutral (W wire). If 115VAC is not present, check as outlined below. If 115VAC is present, check DS, DM winding, and DM auger for binding.
    - (1) "CONTINUOUS" Mode: Engage the ice dispense button, then check for 5VDC from CB K4 connector to pin #5 (P wire) to CB K3 connector pin #1 (open). If 5VDC is not present, check ice dispense switch and DMS continuity.
    - (2) "PORTION" Mode: Engage the ice dispense button, then check for 5VDC from CB K4 connector pin #7 (GY wire) to CB K3 connector pin #1 (open). If 5VDC is not present, check the ice dispense switch and DMS continuity.

b) Opti-Serve Model – **"ICE" and "AM" LEDs are on:**

- (1) "CONTINUOUS" Mode: Before engaging the ice dispense Opti-Serve sensor, check for 5VDC from the locations given in the table below. If VDC is different than in the table, replace CB. If VDC is correct, engage the Opti-Serve sensor and confirm that VDC matches the table below. If not, see "IV.F.3a. Ice Dispense "CONTINUOUS" Mode" to rule out a faulty Opti-Serve sensor. If the Opti-Serve sensor checks out, replace CB. If VDC matches the table below when the Opti-Serve sensor is engaged and ice is not dispensed, check CB K2 connector pin #6 (LBU wire) for 115VAC. If 115VAC is not present, replace CB. If 115VAC is present, check DS and DM continuity. Replace as needed.

Control Board Connector	To	Control Board DC Ground	Disengaged	Engaged
K5 Pin #4 (W/O wire)	To	K3 Pin #1 (open)	0VDC	0VDC
K5 Pin #5 (Y wire)			5VDC	0VDC
K5 Pin #6 (W/BR wire)			5VDC	5VDC

- (2) "PORTION" Mode: Before engaging the ice dispense Opti-Serve sensor, check for 5VDC from the locations given in the table below. If VDC is different than in the table, replace CB. If VDC is correct, engage the Opti-Serve sensor and confirm that VDC matches the table below. If not, see "IV.F.3b. Ice Dispense "PORTION" Mode" to rule out a faulty Opti-Serve sensor. If Opti-Serve sensor checks out, replace CB. If the VDC matches the table below when the Opti-Serve sensor is engaged and ice is not dispensed, check CB K2 connector pin #6 (LBU wire) for 115VAC. If 115VAC is not present, replace CB. If 115VAC is present, check DS and DM continuity. Replace as needed.

Control Board Connector	To	Control Board DC Ground	Disengaged	Engaged
K5 Pin #1 (W/R wire)	To	K3 Pin #1 (open)	0VDC	0VDC
K5 Pin #2 (W/BU wire)			5VDC	0VDC
K5 Pin #3 (W/BK wire)			5VDC	5VDC

- Water Dispense Switch/Water Dispense Sensor

- a) Push Button Model: The water dispense button and DispWV are not associated with CB. Engage the water dispense button, then check for 24VAC at DispWV. If 24VAC is present and no water is dispensed, check for water supply line shut-off valve closed, clogged water filters, clogged WV screen. If the water supply is good, replace DispWV. If 24VAC is not present, check water dispense switch continuity and CT 24VAC fuse, 125VAC power supply, and continuity.
- b) Opti-Serve Model: Before engaging the water dispense Opti-Serve sensor, check for 5VDC from the locations given in the table below. If VDC is different than in the table, replace CB. If 5VDC is present, engage the Opti-Serve sensor and confirm that VDC matches the table below. If not, see "IV.F.3c. Water Dispense" to rule out a faulty Opti-Serve sensor. If the Opti-Serve sensor checks out, replace CB. If VDC matches the table below when the Opti-Serve sensor is engaged, check for 24VAC between CB K2 connector pin #8 (DBU wire) to a neutral (LBU wire) with the Opti-Serve sensor engaged. If 24VAC is not present, replace CB. If 24VAC is present and no water is dispensed, check for water supply line shut-off valve closed, clogged water filters, clogged WV screen. If the water supply is good, replace DispWV.

Control Board Connector	To	Control Board DC Ground	Disengaged	Engaged
K5 Pin #7 (R wire)	To	K3 Pin #1 (open)	0VDC	0VDC
K5 Pin #8 (W wire)			5VDC	0VDC
K5 Pin #9 (BK wire)			5VDC	5VDC

- 5) **Fill Cycle** – CB directs 24VAC power supply to WV from CB K2 connector pin #7 (R wire) to CB K3 connector pin #3 (DBU wire). Confirm 24VAC between CB K2 connector pin #7 (R wire) and pin #8 (LBU wire). Next, confirm 24VAC between CB K3 connector pin #3 (DBU wire) and CB K2 connector pin #8 (LBU) wire. If 24VAC is present between CB K2 connector pin #7 (R wire) and #8 (LBU wire), but not between CB K3 connector pin #3 (DBU wire) and CB K2 connector pin #8 (LBU wire), replace CB. If 24VAC is present between CB K3 connector pin #3 (DBU wire) and CB K2 connector pin #8 (LBU wire) and fill cycle does not start, see "IV.B.8) Fill Cycle."
- 6) **Ice Purge Cycle – "GM" LED is on:** UF/S closes, WCR relay terminal #6 (LBU wire) and #4 (O wire) close. CB K1 connector COM (BR wire) and CB K1 connector NO (DBU wire) contacts close, energizing GM and GMPR. 60-sec. ice purge timer starts. Check for 115VAC at CB K1 connector NO (DBU wire) to a neutral (W wire). If 115VAC is not present, confirm continuity between CB connector K4 pin #3 (GY wire) and #4 (V wire). Next, confirm 115VAC at CB K1 connector COM (BR wire) to a neutral (W wire). If 115VAC is present at CB K1 connector COM (BR wire) but not on NO (DBU wire), and CB K4 connector pin #3 (GY wire) and #4 (V wire) are closed, replace CB.
- 7) **Freeze Cycle – "GM" and "COMP" LEDs are on:** 60-sec. ice purge timer terminates. CB X2 relay energizes, closing X2 relay contacts (BR and LBU wires). Confirm continuity between CB K2 connector pin #1 (DBU wire) and #2 (BR wire). After being closed for 60 seconds, confirm 115VAC between X2 (BR wire) and a neutral (W wire). Next, check for 115VAC between CB X2 (LBU wire) and a neutral (W wire). If 115VAC is present on CB X2 (BR wire), but not on CB X2 (LBU wire) and CB K2 connector pin #1 (DBU wire) and #2 (BR wire) are closed, replace CB.

8) **Drain Cycle – "FLUSH" (drain) LED is on:** 12-hr. DCT terminates or CS is moved to "DRAIN" position. 150-sec. shutdown sequence starts. 90 seconds later, Comp de-energizes and Comp LED turns off. 60 seconds after Comp de-energizes, GM de-energizes and GM LED turns off. Drain cycle starts. "FLUSH" LED turns on and DV energizes. DV de-energizes after 20 minutes when drain cycle is initiated by 12-hr. DCT. When the drain cycle is initiated by CS (manual drain), DV de-energizes when CS is moved to "OFF" position or "ICE" position.

**Push Button Model: "FLUSH" (drain) LED is on.** Confirm 24VAC at CB K2 connector pin #8 (LBU wire) (12-hr. DCT) to CB K4 connector pin #2 (LBU wire). If 24VAC is not present, confirm 24VAC at CB K2 connector pin #7 (R wire) to CB K4 connector pin #2 (LBU wire). If 24VAC is present on CB K4 connector pin #7 (R wire) and not on pin #8 (LBU wire), replace CB. If 24VAC is present, DV energizes and allows water from the evaporator and reservoir to drain for 20 minutes.

**Opti-Serve Model: "FLUSH" (drain) LED is on.** Confirm 24VAC at CB K2 connector pin #10 (LBU wire) (12-hr. DCT) to CB K4 connector pin #2 (LBU wire). If 24VAC is not present and "FLUSH" LED is on (CS in the "ICE" position), replace CB. If 24VAC is present, DV energizes and allows water from the evaporator and reservoir to drain for 20 minutes.

**Manual Drain:** Move CS to the "DRAIN" position. Confirm 24VAC at CB K3 connector pin #3 (DBU wire) to CB K4 connector pin #2 (LBU wire). If 24VAC is not present, replace CB. If 24VAC is present, check CS (LBU wire) to CB K4 connector pin #2 (LBU wire). If 24VAC is not present, replace CS. If 24VAC is present, DV energizes and allows water from the evaporator and reservoir to drain.

9) **Shutdown** – When BC actuator paddle is activated, BC proximity switch opens, 5VDC is interrupted at CB K4 connector pin #3 (GY wire) and #4 (V wire). 150-sec. shutdown sequence starts. 90 seconds after BC opens, Comp de-energizes, 60 seconds later, GM de-energizes. If 5VDC is present from CB K4 connector pin #3 (GY wire) to CB connector pin #4 (V wire), and Comp or GM does not de-energize, replace CB.

Legend: **AM**–agitating motor; **BC**–bin control; **CB**–control board; **Comp**–compressor; **CS**–control switch; **CT**–control transformer; **DCT**–drain cycle timer (12-hr. timer); **DispWV**–dispense water valve; **DM**–dispense motor; **DMS**–dispense mode switch ("CONTINUOUS," or "PORTION"); **DS**–dispense solenoid; **DVT**–drain valve timer (20-min. timer); **FM**–fan motor; **GM**–gear motor; **GMPR**–gear motor protect relay; **LF/S**–lower float switch; **UF/S**–upper float switch; **WCR**–water control relay; **WV**–inlet water valve

## D. Bin Control Check

- 1) Remove the front and top panels.
- 2) Remove the storage bin cover. If necessary, dispense ice so that the BC actuator is not engaged or remove the ice manually. **WARNING! Care should be taken to avoid the agitator during BC testing.**
- 3) Move the control switch to the "OFF" position.
- 4) Move the power switch to the "OFF" position.
- 5) Turn off the power supply.
- 6) Disconnect red BC connector from the back of the control box.
- 7) Check for continuity across BC proximity switch violet (V wire) and orange (O wire). If BC actuator is not engaged and BC proximity switch is open, replace BC proximity switch.
- 8) Press and hold BC actuator paddle. While BC actuator is engaged, check for continuity across BC proximity switch violet (V wire) and orange (O wire). If BC actuator is engaged and BC proximity switch is closed, replace BC proximity switch.
- 9) Disengage BC actuator paddle.
- 10) Connect red BC connector.
- 11) Turn on the power supply. Move the power switch to the "ON" position.
- 12) Move the control switch to the "ICE" position.
- 13) Engage the safety switch to start the automatic icemaking process.
- 14) When Comp starts, press and hold BC actuator paddle.
- 15) The 150-sec. shutdown sequence starts. 90 seconds after BC opens, Comp de-energizes, 60 seconds later, GM de-energizes. If 5VDC is present at CB K4 connector pin #3 (GY wire) to #4 (V wire), and Comp or GM does not de-energize, replace CB.

Legend: **BC**—bin control; **CB**—control board; **Comp**—compressor; **GM**—gear motor

## **E. Float Switch Check and Cleaning**

### **1. Float Switch Check**

- 1) Remove the front panel, then make sure the power switch is in the "ON" position.
- 2) Move the control switch to the "DRAIN" position.
- 3) Engage the safety switch and allow the evaporator and reservoir to drain.
- 4) Disengage the safety switch, then move the power switch to the "OFF" position and the control switch to the "OFF" position.
- 5) Turn off the power supply.
- 6) Disconnect F/S connector and check F/S continuity. Both UF/S and LF/S should be open. Check continuity between F/S common (BK wire) and UF/S (R wire). Next, check continuity between F/S common (BK wire) and LF/S (DBU wire). If both are open, continue to step 7. If either are closed, follow the steps in "IV.E.2. Float Switch Cleaning." After cleaning F/S, check UF/S and LF/S again. Replace if necessary.
- 7) Reconnect F/S connector.
- 8) Move the power switch to the "ON" position.
- 9) Turn on the power supply.
- 10) Move the control switch to the "ICE" position.
- 11) Engage the safety switch.
- 12) Once the reservoir is full and GM starts, disengage the safety switch, then move the power switch to the "OFF" position and the control switch to the "OFF" position.
- 13) Turn off the power supply.
- 14) Remove F/S connector and check F/S continuity. Both UF/S and LF/S should be closed. Check continuity between F/S common (BK wire) and UF/S (R wire). Next, check continuity between F/S common (BK wire) and LF/S (DBU wire). If either are open, follow the steps in "IV.E.2. Float Switch Cleaning." After cleaning F/S, check UF/S and LF/S again. Replace if necessary.
- 15) Reconnect F/S connector.
- 16) Move the power switch to the "ON" position and the control switch to the "ICE" position.
- 17) Replace the front panel in its correct position.
- 18) Turn on the power supply to start the automatic icemaking process.

## 2. Float Switch Cleaning

Depending on local water conditions, scale may build up on F/S. Scale on F/S can cause inconsistent operation of UF/S and LF/S. In this case, both UF/S and LF/S should be cleaned and checked.

- 1) Move the control switch to the "OFF" position.
- 2) Remove the front panel, then move the power switch to the "OFF" position.
- 3) Turn off the power supply.
- 4) Remove F/S assembly from the reservoir cover. See Fig. 1.
- 5) Wipe down F/S assembly with a mixture of 1 part Hoshizaki "Scale Away" and 25 parts warm water. Rinse the assembly thoroughly with clean water.
- 6) While not necessary, the floats can be removed from the shaft during cleaning. If you remove them, note that the blue float is on top (UF/S) and the white float is on bottom (LF/S). The floats must be installed with the magnets inside them towards the top of the switch. See Fig. 1. Installing the floats upside down will affect the timing of F/S operation.
- 7) Rinse F/S assembly thoroughly with clean water and replace in its correct position.
- 8) Move the power switch to the "ON" position.
- 9) Replace the front panel in its correct position.
- 10) Turn on the power supply.
- 11) Move the control switch to the "ICE" position to start the automatic icemaking process.

Legend: **F/S**—float switch; **GM**—gear motor; **LF/S**—lower float switch; **UF/S**—upper float switch

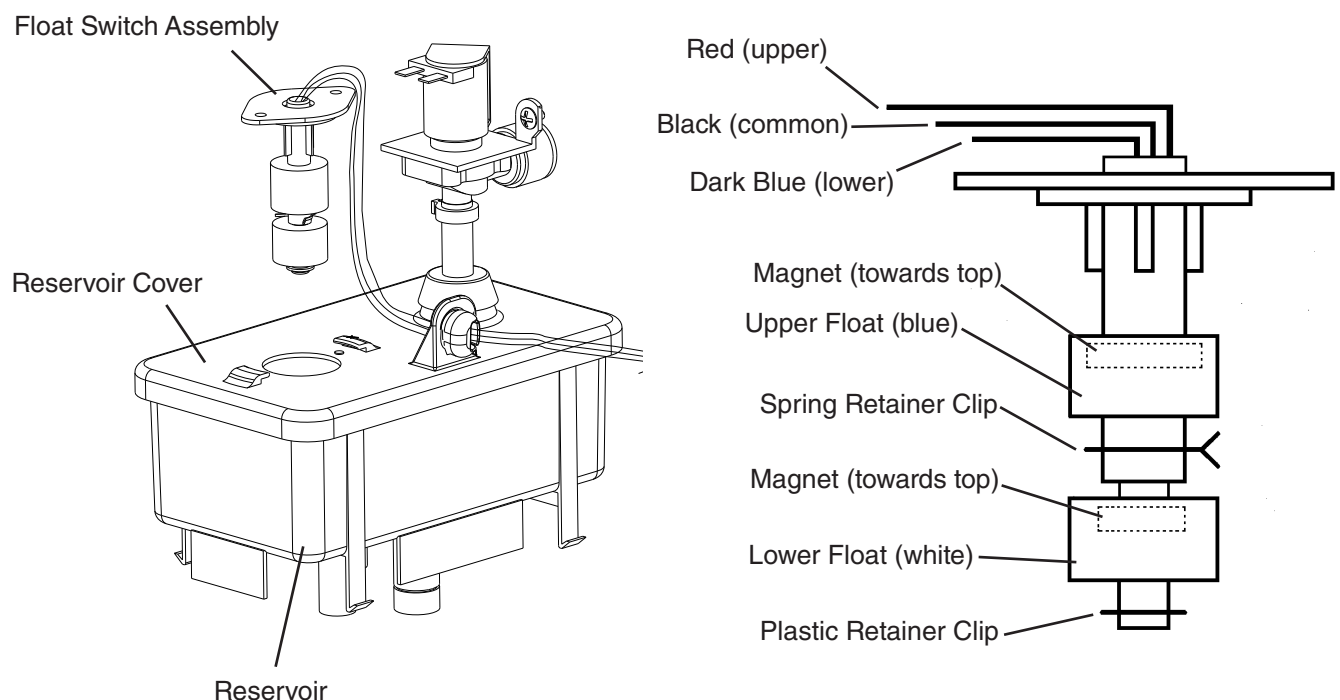

**Fig. 1**

## F. Diagnostic Charts

Before consulting the diagnostic charts, check for correct installation, proper voltage per unit nameplate, and adequate water pressure (10 to 113 PSIG). Check CB using the steps in "IV.C. Control Board Check."

### 1. No Ice Production

<b>Startup</b>	
1. Power Supply	a) Off, blown fuse, or tripped breaker.
	b) Not within specifications.
2. Water Supply	a) Water supply off or improper water pressure.
	b) External water filters clogged.
3. Power Switch	a) "OFF" position or defective.
4. Safety Switch	a) Not engaged or defective.
5. Power Protect Relay	a) Voltage not within specifications.
	b) Defective.
6. Control Transformer (115VAC, 24VAC, and 10.5VAC)	a) Coil winding open or shorted.
7. 1A Fuse (24VAC Control Board)	a) Blown.
8. .5A Fuse (10.5VAC Control Board)	a) Blown.
9. Control Board See "IV.C. Control Board Check"	a) Defective.
10. Control Switch	a) In "OFF" or "DRAIN" position.
	b) Defective.
11. Bin Control	a) Tripped with bin filled with ice.
	b) Proximity switch stuck open.
	c) Actuator paddle does not move freely.
12. High-Pressure Switch	a) Dirty condenser.
	b) Ambient temperature too warm.
	c) Fan motor not operating.
	d) Refrigerant overcharged.
	e) Bad contacts.
	f) Refrigerant lines or components restricted.
<b>Fill Cycle</b>	
1. Water Control Relay	a) Energized (upper float switch stuck closed).
	b) Defective.
2. Inlet Water Valve	a) Screen or orifice clogged.
	b) Coil winding open.
3. Float Switch See "IV.E. Float Switch Check and Cleaning"	a) Float does not move freely.
	b) Defective.

<b>Ice Purge Cycle</b>	
1. Control Board	a) No power to gear motor.
2. Gear Motor	a) External protector (gear motor overload) open.
	b) Internal protector open.
	c) Motor winding open.
	d) Mechanical failure.
3. Coupling	a) Defective.
<b>Freeze Cycle</b>	
1. Control Board	a) Defective.
2. Compressor	a) External protector open.
	b) Motor winding open.
	c) Capacitor defective.
	d) Start relay defective.
	e) Mechanical failure.
3. Fan Motor	a) Motor winding or internal protector open.
	b) Bearing worn out or locked rotor.
4. Evaporator	a) Dirty.
	b) Damaged or defective.
5. Thermostatic Expansion Valve (TXV)	a) Bulb loose.
	b) Operating erratically.
6. Refrigerant Charge	a) Low.
7. Drain Valve	a) Dirty, leaking by.
	b) Defective coil.
8. Water System	a) Water leaks.
<b>Refill</b>	
1. Water Supply	a) Off.
2. Float Switch See "IV.E. Float Switch Check and Cleaning."	a) Float does not move freely.
	b) Defective.
3. Water Control Relay	a) Energized (upper float switch stuck closed).
	b) Defective.
4. Inlet Water Valve	a) Screen or orifice clogged.
	b) Coil winding open.
<b>Shutdown</b>	
1. Bin Control	a) Not enough ice in bin to trip actuator paddle.
	b) Proximity switch defective.
	c) Actuator paddle does not move freely.
2. Control Board	a) Defective.

## 2. Ice/Water Dispense

<b>Ice Dispense Push Button</b>	
1. Power Supply	a) See "Startup."
2. Control Board	a) Ice dispense switch circuit open or no power.
	b) No power to ice dispense solenoid, ice dispense motor, or agitating motor.
3. Ice Dispense Switch	a) Defective.
4. Dispense Mode Switch	a) Defective (open).
5. Ice Dispense Motor	a) Open windings.
	b) Mechanical failure.
6. Ice Dispense Solenoid	a) Defective or loose connection.
7. Shutter Assembly	a) Mechanical failure.
8. Agitating Motor	a) Open windings.
	b) Mechanical failure.
<b>Ice Dispense Opti-Serve</b>	
1. Power Supply	a) See "Startup."
2. Control Board	a) No power to dispense mode switch.
	b) Dispense mode switch circuit open.
	c) No power to ice dispense solenoid, ice dispense motor or agitating motor.
3. Infrared Sensor	a) Defective.
4. Dispense Mode Switch	a) Defective (open).
5. Ice Dispense Motor	a) Open windings.
	b) Mechanical failure.
6. Ice Dispense Solenoid	a) Defective or loose connection.
7. Shutter Assembly	a) Mechanical failure.
8. Agitating Motor	a) Open windings.
	b) Mechanical failure.
<b>Water Dispense Push Button</b>	
1. Power Supply	a) See "Startup."
2. Infrared Sensor	a) Defective.
3. Water Dispense Switch	a) Defective.
4. Water Dispense Valve	a) Water supply turned off.
	b) Defective.
<b>Water Dispense Opti-Serve</b>	
1. Power Supply	a) See "Startup."
2. Infrared Sensor	a) Defective.
3. Control Board	a) No power to infrared sensor.
	b) No power to water dispense valve.
4. Water Dispense Valve	a) Water supply turned off.
	b) Defective.

### 3. Opti-Serve (OS) Sensors

Be sure to check all items in section "IV.F.2. Ice/Water Dispense" prior to using this chart. Use the following charts along with the wiring diagram to troubleshoot the OS sensors.

Ice Sensor	
1. OS Sensor	a) Dirty.
	b) Defective. See chart 3a and 3b.
2. Control Board	a) No power to infrared sensor.
	b) Not reading infrared sensor signal.
Water Sensor	
1. OS Sensor	a) Dirty.
	b) Defective. See chart 3c.
2. Control Board	a) No power to infrared sensor.
	b) Not reading infrared sensor signal.

#### 3a. Ice Dispense "Continuous"

Component	Control Board	Sensor	To	Control Board /Other	Sensor	Engaged	Disengaged
Solenoid	K2 Pin 6 (LBU wire)	-	To	Neutral/GND	-	120VAC	0VAC
Sensor	K5 Pin 4 (W/O wire)	(R wire)	To	K5 Pin 5 (Y wire)	(W wire)	5VDC	0VDC
				K5 Pin 6 (W/BR wire)	(BK wire)	5VDC	5VDC

#### 3b. Ice Dispense "Portion"

Component	Control Board	Sensor	To	Control Board /Other	Sensor	Engaged	Disengaged
Solenoid	K2 Pin 6 (LBU wire)	-	To	Neutral/GND	-	120VAC	0VAC
Sensor	K5 Pin 1 (W/R wire)	(R wire)	To	K5 Pin 2 (W/BU wire)	(W wire)	5VDC	0VDC
				K5 Pin 3 (W/BK wire)	(BK wire)	5VDC	5VDC

#### 3c. Water Dispense

Component	Control Board	To	Control Board /Other	Engaged	Disengaged
Solenoid	K2 Pin 8 (DBU wire)	To	K4 Pin 2 (LBU wire)	24VAC	0VAC
Sensor	K5 Pin 7 (R wire)	To	K5 Pin 8 (W wire)	5VDC	0VDC
			K5 Pin 9 (BK wire)	5VDC	5VDC

## V. Removal and Replacement of Components

### **WARNING**

- This icemaker should be diagnosed and repaired only by qualified service personnel to reduce the risk of death, electric shock, serious injury, or fire.
- Move the power switch to the "OFF" position and turn off the power supply to the icemaker before servicing. Lockout/Tagout to prevent the power from being turned back on inadvertently.
- **CHOKING HAZARD:** Ensure all components, fasteners, and thumbscrews are securely in place after the equipment is serviced. Make sure that none have fallen into the storage bin.
- Make sure all food zones in the icemaker and storage bin are clean after the icemaker is serviced. For cleaning procedures, see "VI. Cleaning and Maintenance."
- When replacing evaporator assembly and water circuit components, make sure there are no water leaks after the repair is complete.

## A. Service for Refrigerant Lines

### **WARNING**

- Repairs requiring the refrigeration circuit to be opened must be performed by properly trained and EPA-certified service personnel.
- Always recover the refrigerant and store it in an approved container. Do not discharge the refrigerant into the atmosphere.
- Use an electronic leak detector or soap bubbles to check for leaks. Add a trace of refrigerant to the system (if using an electronic leak detector), and then raise the pressure using nitrogen gas (140 PSIG). DO NOT use R-404A as a mixture with pressurized air for leak testing.

### **NOTICE**

- Do not leave the system open for longer than 15 minutes when replacing or servicing parts. The Polyol Ester (POE) oils used in R-404A units can absorb moisture quickly. Therefore it is important to prevent moisture from entering the system when replacing or servicing parts.
- Always install a new drier every time the sealed refrigeration system is opened.
- Do not replace the drier until after all other repair or replacement has been made. Install the new drier with the arrow on the drier in the direction of the refrigerant flow.
- When brazing, protect the drier by using a wet cloth to prevent the drier from overheating. Do not allow the drier to exceed 250°F (121°C).

## 1. Refrigerant Recovery

This icemaker is provided with refrigerant access valves. Using proper refrigerant practices, recover the refrigerant from the service valves and store it in an approved container. Do not discharge the refrigerant into the atmosphere.

## 2. Brazing

### **⚠ WARNING**

- R-404A itself is not flammable at atmospheric pressure and temperatures up to 176°F (80°C).
- R-404A itself is not explosive or poisonous. However, when exposed to high temperatures (open flames), R-404A can be decomposed to form hydrofluoric acid and carbonyl fluoride both of which are hazardous.
- Do not use silver alloy or copper alloy containing arsenic.
- Use an electronic leak detector or soap bubbles to check for leaks. Add a trace of refrigerant to the system (if using an electronic leak detector), and then raise the pressure using nitrogen gas (140 PSIG). DO NOT use R-404A as a mixture with pressurized air for leak testing.

1) Braze all fittings while purging with nitrogen gas flowing at a pressure of 3 to 4 PSIG.

### **NOTICE**

- Always install a new drier every time the sealed refrigeration system is opened.
- Do not replace the drier until after all other repair or replacement has been made. Install the new drier with the arrow on the drier in the direction of the refrigerant flow.
- When brazing, protect the drier by using a wet cloth to prevent the drier from overheating. Do not allow the drier to exceed 250°F (121°C).

2) Use an electronic leak detector or soap bubbles to check for leaks. Add a trace of refrigerant to the system (if using an electronic leak detector), and then raise the pressure using nitrogen gas (140 PSIG). DO NOT use R-404A as a mixture with pressurized air for leak testing.

## 3. Evacuation and Recharge (R-404A)

1) Attach a vacuum pump to the system. Be sure to connect charging hoses to both high and low-side access valves.

### **IMPORTANT**

The vacuum level and vacuum pump may be the same as those for current refrigerants. However, the rubber hose and gauge manifold to be used for evacuation and refrigerant charge should be exclusively for POE oils.

2) Turn on the vacuum pump. Open the gauge manifold valves. Never allow the oil in the vacuum pump to flow backwards.

3) Allow the vacuum pump to pull down to a 29.9" Hg vacuum. Evacuating period depends on pump capacity.

- 4) Close the low-side valve and high-side valve on the gauge manifold.
- 5) Disconnect the gauge manifold hose from the vacuum pump and attach it to a refrigerant service cylinder. Remember to loosen the connection and purge the air from the hose. See the rating label inside the icemaker for the required refrigerant charge. Hoshizaki recommends only virgin refrigerant or reclaimed refrigerant which meets ARI Standard 700 (latest edition) be used.
- 6) A liquid charge is required for charging an R-404A system (to prevent fractionation). Place the service cylinder on the scales: if the service cylinder is not equipped with a dip tube, invert the service cylinder, then place it on the scales. Open the high-side valve on the gauge manifold.
- 7) Allow the system to charge with liquid until the proper charge weight is met.
- 8) If necessary, add any remaining charge to the system through the low-side.  
**NOTICE! To prevent compressor damage, use a throttling valve or liquid dispensing device to add the remaining liquid charge through the low-side access valve with the icemaker running.**
- 9) Close the high and low-side gauge manifold valves, then disconnect the gauge manifold hoses.
- 10) Cap the access valves to prevent a possible leak.

## B. Important Notes for Component Replacement

<b>NOTICE</b>	
When replacing a component listed below, see the notes to help ensure proper operation.	

Component	Notes
Compressor	Install a new drier, start capacitor, and start relay.
Expansion Valve	<ul style="list-style-type: none"> <li>• Install a new drier.</li> <li>• Attach the expansion valve bulb to the suction line in the same location as the previous bulb.</li> <li>• The bulb should be between the 10 and 2 o'clock positions on the tube.</li> <li>• Secure the bulb with the clamp and holder, then insulate it.</li> </ul>
Upper and Lower Bearings	<ul style="list-style-type: none"> <li>• Inspect the upper bearing for wear. See "V.B.1. Upper Bearing Wear Check." Replace if necessary.</li> <li>• When replacing the upper bearing it is advised to also change the lower bearing at the same time.</li> </ul>
Evaporator	<ul style="list-style-type: none"> <li>• Install a new drier.</li> <li>• Inspect the mechanical seal and O-ring prior to installing the new evaporator. If worn, cracked, or scratched, the mechanical seal should also be replaced.</li> </ul>
Gear Motor	Install a new gear motor capacitor.

# Evaporator Assembly

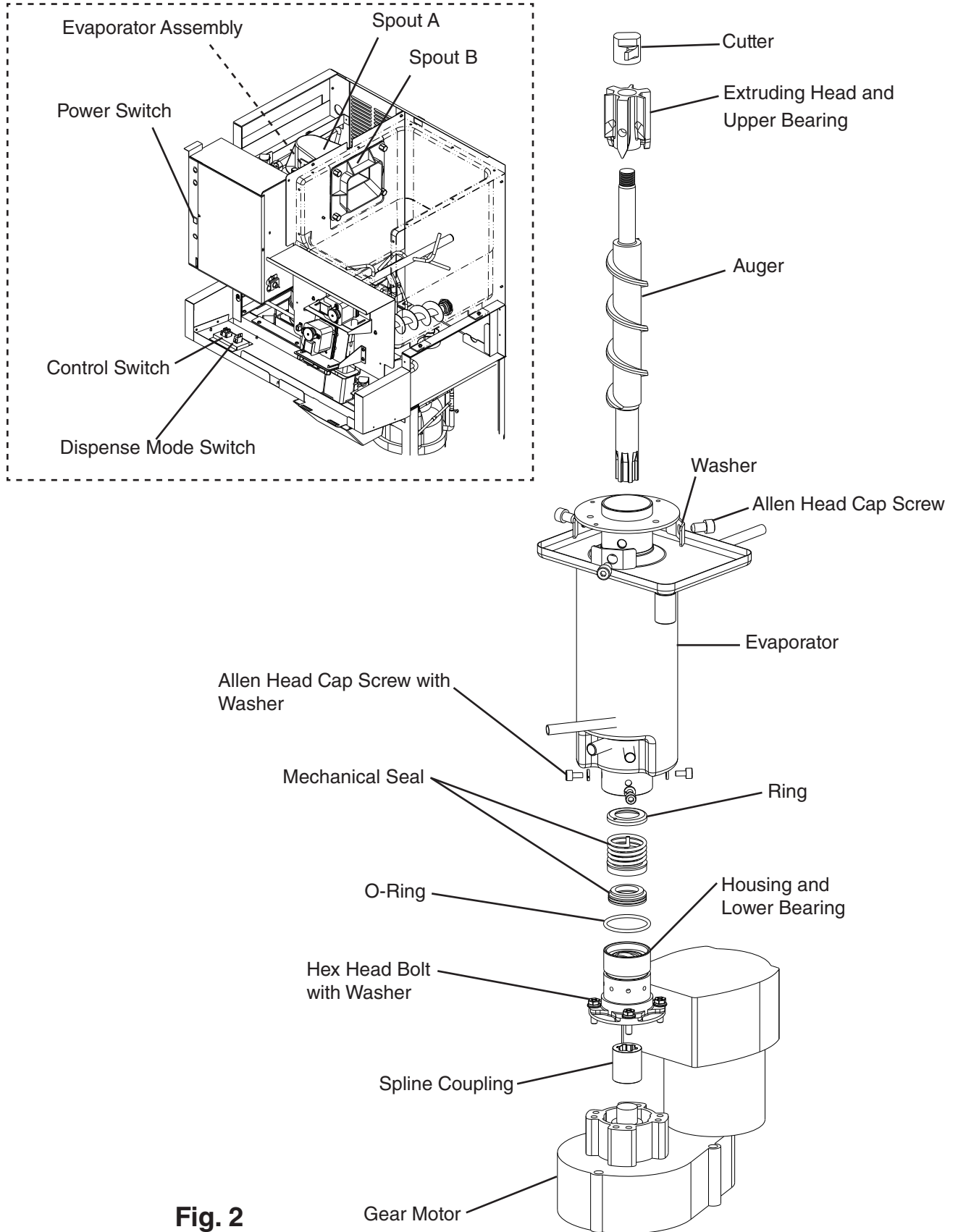
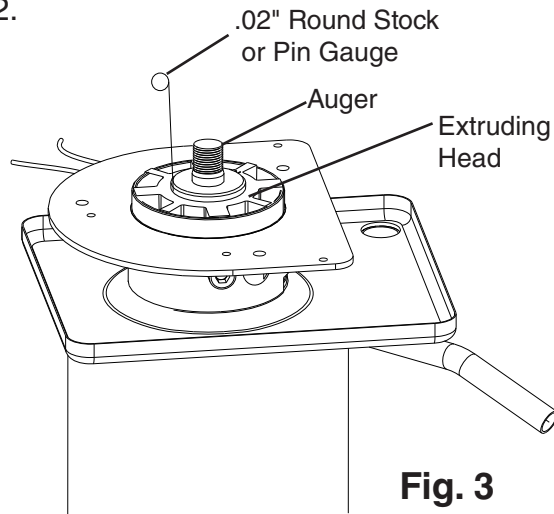

**Fig. 2**

## 1. Upper Bearing Wear Check

To ensure that the bearing inside the extruding head does not exceed the wear tolerance of .02", follow the instructions below. See Fig. 3.

- 1) Move the control switch to the "OFF" position, then turn off the power supply. Remove the front and top panels, then move the power switch to the "OFF" position.
- 2) Remove the front cover of the storage bin. Remove spout B, then remove spout A and the cutter. See Fig. 2.
- 3) Grasp the top of the auger and move the auger towards you, then try to insert a .02" round stock or pin gauge in between the back side of the auger shaft and the bearing surface. Check several locations around the auger shaft. If the gauge goes between the shaft and the bearing at any point or if the bearing is scratched or cracked, both the top bearing in the extruding head and the lower bearing in the housing should be replaced. Instructions for removing the extruding head and housing are located later in this procedure.



**Fig. 3**

Note: Replacing the bearing requires a bearing press adaptor. If one is not available, replace the whole extruding head and housing.

- 4) Replace the cutter, spout A, spout B, and the front cover of the storage bin in their correct positions.
- 5) Move the power switch to the "ON" position, then replace the panels in their correct positions.
- 6) Turn on the power supply, then move the control switch to the "ICE" position to start the automatic icemaking process.

## 2. Removal and Replacement of Extruding Head

- 1) Move the control switch to the "DRAIN" position and drain all of the water from the evaporator.
- 2) After the water has stopped draining, move the control switch to the "OFF" position, then turn off the power supply. Remove the front and top panels, then move the power switch to the "OFF" position.
- 3) Remove the front cover of the storage bin. Remove spout B, then remove spout A and the cutter. See Fig. 2.
- 4) Remove the apron panel, then remove the left side panel.
- 5) Remove the allen head cap screws and lift off the extruding head.
- 6) Place the new extruding head in place and tighten down the allen head cap screws.
- 7) Replace the cutter in its correct position.
- 8) Replace spout A, spout B, and the front cover of the storage bin in their correct positions.

- 9) Move the power switch to the "ON" position, then replace the panels in their correct positions.
- 10) Turn on the power supply, then move the control switch to the "ICE" position to start the automatic icemaking process.

### 3. Removal and Replacement of Auger

- 1) Move the control switch to the "DRAIN" position and drain all of the water from the evaporator.
- 2) After the water has stopped draining, move the control switch to the "OFF" position, then turn off the power supply. Remove the front and top panels, then move the power switch to the "OFF" position.
- 3) Remove the front cover of the storage bin. Remove spout B, then remove spout A. See Fig. 2.
- 4) Remove the apron panel, then remove the left side panel.
- 5) Remove the allen head cap screws securing the extruding head. Using the cutter, lift out the auger assembly.
- 6) Remove the cutter, extruding head, and upper part of the mechanical seal from the auger and place them on the new auger. **NOTICE! To help prevent water leaks, be careful not to damage the surfaces of the O-ring or mechanical seal.**
- 7) Install the new auger assembly with the upper part of the mechanical seal attached and tighten down the allen head cap screws.
- 8) Replace spout A, spout B, and the front cover of the storage bin in their correct positions.
- 9) Move the power switch to the "ON" position, then replace the panels in their correct positions.
- 10) Turn on the power supply, then move the control switch to the "ICE" position to start the automatic icemaking process.

### 4. Removal and Replacement of Evaporator

#### **NOTICE**

- Always install a new drier every time the sealed refrigeration system is opened.
- Do not replace the drier until after all other repair or replacement has been made. Install the new drier with the arrow on the drier in the direction of the refrigerant flow.
- When brazing, protect the drier by using a wet cloth to prevent the drier from overheating. Do not allow the drier to exceed 250°F (121°C).

- 1) Move the control switch to the "DRAIN" position and drain all of the water from the evaporator.
- 2) After the water has stopped draining, move the control switch to the "OFF" position, then turn off the power supply. Remove the front and top panels, then move the power switch to the "OFF" position.

- 3) Remove the apron panel, then remove the left side panel.
- 4) Recover the refrigerant and store it in an approved container.
- 5) Remove the front cover of the storage bin. Remove spout B, then remove spout A. See Fig. 2.
- 6) Remove the allen head cap screws securing the extruding head. Using the cutter, lift out the auger assembly.
- 7) Remove the evaporator bracket and disconnect the water hoses.
- 8) Disconnect the inlet and outlet tubing.
- 9) Remove the allen head cap screws securing the evaporator to the lower housing.
- 10) Lift off the evaporator.
- 11) Inspect the mechanical seal and O-ring prior to installing the new evaporator. The mechanical seal consists of two parts. One moves along with the auger, and the other is fixed on the lower housing. **NOTICE! If the contact surfaces of these two parts are worn, cracked, or scratched, the mechanical seal may cause water leaks and should be replaced.** Instructions for removing the mechanical seal and lower housing are located later in this procedure.
- 12) Make sure the lower mechanical seal is in place, then place the new evaporator in position. Secure the evaporator to the lower housing using the allen head cap screws.
- 13) Remove the drier, then place the new drier in position.
- 14) Braze all fittings while purging with nitrogen gas flowing at a pressure of 3 to 4 PSIG.
- 15) Use an electronic leak detector or soap bubbles to check for leaks. Add a trace of refrigerant to the system (if using an electronic leak detector), and then raise the pressure using nitrogen gas (140 PSIG). DO NOT use R-404A as a mixture with pressurized air for leak testing.
- 16) Evacuate the system, and charge it with refrigerant. See the nameplate for the required refrigerant charge.
- 17) Install the auger assembly with the upper part of the mechanical seal attached and tighten down the allen head cap screws.
- 18) Replace the evaporator bracket and reconnect the water hoses.
- 19) Replace spout A, spout B, and the front cover of the storage bin in their correct positions.
- 20) Move the power switch to the "ON" position, then replace the panels in their correct positions.
- 21) Turn on the power supply, then move the control switch to the "ICE" position to start the automatic icemaking process.

## 5. Removal and Replacement of Mechanical Seal and Lower Housing

### 5a. Mechanical Seal

- 1) Move the control switch to the "DRAIN" position and drain all of the water from the evaporator.
- 2) After the water has stopped draining, move the control switch to the "OFF" position, then turn off the power supply. Remove the front and top panels, then move the power switch to the "OFF" position.
- 3) Remove the front cover of the storage bin. Remove spout B, then remove spout A. See Fig. 2.
- 4) Remove the apron panel, then remove the left side panel.
- 5) Remove the extruding head heater and the allen head cap screws securing the extruding head.
- 6) Using the cutter, lift out the auger assembly, then remove the evaporator bracket.
- 7) The mechanical seal consists of two parts. One moves along with the auger, and the other is fixed on the lower housing. **NOTICE! If the contact surfaces of these two parts are worn, cracked, or scratched, the mechanical seal may cause water leaks and should be replaced.**
- 8) Remove the allen head cap screws securing the evaporator to the lower housing.
- 9) Raise the evaporator up to access the lower housing.
- 10) Remove the mechanical seal from the housing. If only replacing the mechanical seal, proceed to step 13. **NOTICE! To help prevent water leaks, be careful not to damage the surfaces of the O-ring or mechanical seal.**

### 5b. Lower Housing

- 11) Remove the O-ring and the bolts securing the housing to the gear motor and remove the housing from the gear motor. If inspection of the upper bearing inside the extruding head (see "V.D.1. Upper Bearing Wear Check") indicates that it is out of tolerance, replace both it and the bearing inside the lower housing.  
Note: Replacing the bearing requires a bearing press adaptor. If one is not available, replace the whole extruding head and housing.
- 12) Install the O-ring and mount the lower housing on the gear motor.
- 13) Install the lower part of the mechanical seal on the lower housing.
- 14) Lower the evaporator down and secure it to the lower housing.
- 15) Install the auger assembly with the upper part of the mechanical seal attached.
- 16) Replace the evaporator bracket in its correct position.
- 17) Replace spout A, spout B, and the front cover of the storage bin in their correct positions.
- 18) Move the power switch to the "ON" position, then replace the panels in their correct positions.
- 19) Turn on the power supply, then move the control switch to the "ICE" position to start the automatic icemaking process.

## 6. Removal and Replacement of Gear Motor

- 1) Move the control switch to the "DRAIN" position and drain all of the water from the evaporator.
- 2) After the water has stopped draining, move the control switch to the "OFF" position, then turn off the power supply. Remove the front and top panels, then move the power switch to the "OFF" position.
- 3) Remove the front cover of the storage bin. Remove spout B, then remove spout A. See Fig. 2.
- 4) Remove the apron panel, then remove the left side panel.
- 5) Remove the evaporator bracket.
- 6) Remove the bolts securing the lower housing to the gear motor. Lift the evaporator up slightly.
- 7) Remove the 3 gear motor bolts.
- 8) Disconnect the wiring from the gear motor, then remove the gear motor.
- 9) Remove the spline coupling from the old gear motor and attach to the new gear motor.
- 10) Place the new gear motor in the drain pan.
- 11) Secure the gear motor.
- 12) Connect the gear motor wires.
- 13) Lower the evaporator down and secure it to the gear motor.
- 14) Replace the evaporator bracket in its correct position.
- 15) Replace spout A, spout B, and the front cover of the storage bin in their correct positions.
- 16) Move the power switch to the "ON" position, then replace the panels in their correct positions.
- 17) Turn on the power supply, then move the control switch to the "ICE" position to start the automatic icemaking process.

## 7. Dispense Auger and Agitator

- 1) Move the control switch to the "OFF" position, then turn off the power supply. Remove the front and top panels, then move the power switch to the "OFF" position.
- 2) Remove the front cover of the storage bin.
- 3) Remove the thumbscrews from the vertical plane, then loosen the thumbscrews from the horizontal plane of the motor bracket. Slide the motor back.  
Note: Hold the dispense auger/agitator to prevent it from dropping when sliding back the motor. See Fig. 4.
- 4) Replace the dispense auger/agitator with the new one.
- 5) Assemble the removed parts in the reverse order of which they were removed.
- 6) Move the power switch to the "ON" position, then replace the panels in their correct positions.
- 7) Turn on the power supply, then move the control switch to the "ICE" position to start the automatic icemaking process.

## 8. Dispense or Agitating Motor

- 1) Move the control switch to the "OFF" position, then turn off the power supply. Remove the front and top panels, then move the power switch to the "OFF" position.
- 2) Remove the storage bin front panel.
- 3) Remove the thumbscrews from the vertical plane, then loosen the thumbscrews from the horizontal plane of the motor bracket. Slide the motor back.  
Note: Hold the dispense auger/agitator to prevent it from dropping when sliding back the motor. See Fig. 4.
- 4) Remove the thumbscrews from the horizontal plane of the motor bracket.
- 5) Remove the motor from the bracket.
- 6) Install the new motor.
- 7) Assemble the removed parts in the reverse order of which they were removed.
- 8) Move the power switch to the "ON" position, then replace the panels in their correct positions.
- 9) Turn on the power supply, then move the control switch to the "ICE" position to start the automatic icemaking process.

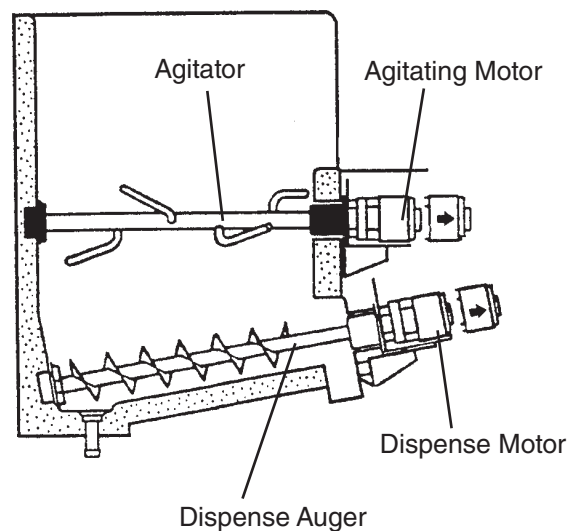

**Fig. 4**

## VI. Cleaning and Maintenance

This icemaker must be cleaned and maintained in accordance with the instruction manual and labels provided with the icemaker. Consult with your local distributor about cleaning and maintenance service. To obtain the name and phone number of your local distributor, visit [www.hoshizaki.com](http://www.hoshizaki.com) or call Hoshizaki Technical Support at 1-800-233-1940 in the USA.

### ⚠ WARNING

- Only qualified service technicians should service this icemaker.
- **CHOKING HAZARD:** Ensure all components, fasteners, and thumbscrews are securely in place after any cleaning or maintenance is done to the icemaker. Make sure that none have fallen into the dispenser unit/storage bin.
- The storage bin is for ice use only. Do not store anything else in the storage bin.

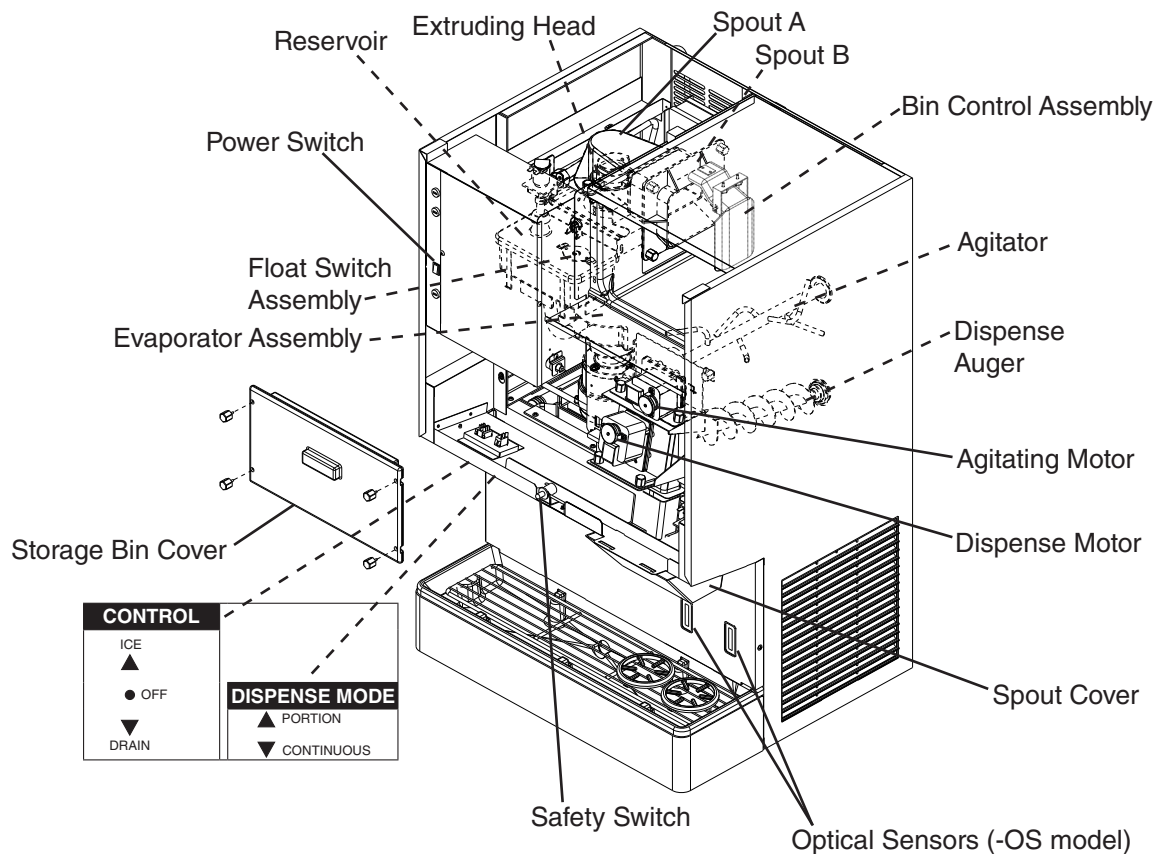

Fig. 5

## A. Cleaning and Sanitizing Instructions

Hoshizaki recommends cleaning and sanitizing this icemaker at least twice a year. More frequent cleaning and sanitizing, however, may be required in some existing water conditions.

### **⚠ WARNING**

- To prevent injury to individuals and damage to the icemaker, do not use ammonia type cleaners.
- Carefully follow any instructions provided with the bottles of cleaning and sanitizing solution.
- Always wear liquid-proof gloves and goggles to prevent the cleaning and sanitizing solutions from coming into contact with skin or eyes.
- After cleaning and sanitizing, do not use ice made from the cleaning and sanitizing solutions. Be careful not to leave any solution on the parts or in the dispenser unit/storage bin.

### 1. Water System

#### a) *Cleaning Solution*

Dilute 9.6 fl. oz. (0.29 l) of Hoshizaki "Scale Away" with 1.6 gal. (6.0 l) of warm water.

#### b) *Cleaning Procedure*

- 1) Close the icemaker water supply line shut-off valve.
- 2) Move the control switch to the "DRAIN" position. See Fig. 5. Allow the water system to drain for 5 minutes.
- 3) Move the dispense mode switch to the "CONTINUOUS" position, then dispense all of the ice from the storage bin.  
Note: Ice dispenses continuously for a maximum of 60 seconds per activation.
- 4) Move the control switch to the "OFF" position, then turn off the power supply. Remove the front and top panels, then move the power switch to the "OFF" position.
- 5) Remove the storage bin cover. Remove spout B, then remove spout A.
- 6) Pour the cleaning solution over the extruding head until the evaporator assembly and the reservoir are full and the solution starts to overflow into the drain pan.  
Note: If there is excess scale on the extruding head, fill the evaporator assembly and reservoir as described above, then use a clamp on the reservoir hose between the reservoir and evaporator assembly to block flow. Pour additional cleaning solution over the extruding head until the evaporator assembly is completely full.
- 7) Replace spout A, spout B, and the storage bin cover in their correct positions.
- 8) Allow the icemaker to sit for 10 minutes before operation. If you placed a clamp on the reservoir hose in step 6, remove it before operation.

- 9) In bad or severe water conditions, clean the float switch assembly as described below. Otherwise, continue to step 10.
  - a. Remove the float switch assembly from the reservoir cover.
  - b. Wipe down the float switch assembly with the cleaning solution.
  - c. Rinse the float switch assembly thoroughly with clean water.
  - d. Replace the float switch assembly in its correct position.
- 10) Move the power switch to the "ON" position and replace the panels in their correct positions. Turn on the power supply, then move the control switch to the "ICE" position. Make ice using the solution until the icemaker stops making ice.  
Note: This icemaker will not run if the safety switch is not engaged.
- 11) Move the control switch to the "DRAIN" position. Allow the water system to drain for 5 minutes.
- 12) Move the control switch to the "ICE" position. Open the icemaker water supply line shut-off valve to supply water to the reservoir.
- 13) After the gear motor starts, move the control switch to the "DRAIN" position. Allow the water system to drain for 5 minutes.  
Note: If you do not sanitize the icemaker, move the control switch to the "ICE" position after the water system drains. Allow the icemaker to run for 30 minutes, then move the control switch to the "OFF" position. Turn off the power supply, then remove the front panel and storage bin cover. Move the power switch to the "OFF" position. Go to step 12 in "VI.A.2.c) Cleaning and Sanitizing Procedure" under "2. Dispense Components."
- 14) Move the control switch to the "OFF" position, then turn off the power supply.
- 15) Close the icemaker water supply line shut-off valve.

**c) Sanitizing Solution**

Dilute 0.82 fl. oz. (25 ml) of a 5.25% sodium hypochlorite solution (chlorine bleach) with 1.6 gal. (6.0 l) of warm water.

**d) Sanitizing Procedure - Following Cleaning Procedure**

- 1) Make sure the control switch is in the "OFF" position, the power supply is off, and the icemaker water supply line shut-off valve is closed.
- 2) Remove the front and top panels, then move the power switch to the "OFF" position.
- 3) Remove the storage bin cover. Remove spout B, then remove spout A.
- 4) Pour the sanitizing solution over the extruding head until the evaporator assembly and the reservoir are full and the solution starts to overflow into the drain pan.
- 5) Replace spout A, spout B, and the storage bin cover in their correct positions.
- 6) Allow the icemaker to sit for 10 minutes before operation.
- 7) Move the power switch to the "ON" position and replace the panels in their correct positions. Turn on the power supply, then move the control switch to the "ICE" position. Make ice using the solution until the icemaker stops making ice.
- 8) Move the control switch to the "DRAIN" position. Allow the water system to drain for 5 minutes.

- 9) Move the control switch to the "ICE" position. Open the icemaker water supply line shut-off valve to supply water to the reservoir.
- 10) After the gear motor starts, move the control switch to the "DRAIN" position. Allow the water system to drain for 5 minutes.
- 11) Move the control switch to the "ICE" position. Allow the icemaker to run for 30 minutes, then clean and sanitize the dispense components as outlined below.

## 2. Dispense Components

Perform after cleaning and sanitizing the water system as outlined above.

### a) Cleaning Solution

Dilute 9.6 fl. oz. (0.29 l) of Hoshizaki "Scale Away" with 1.6 gal. (6.0 l) of warm water.

### b) Sanitizing Solution

Dilute 0.82 fl. oz. (25 ml) of a 5.25% sodium hypochlorite solution (chlorine bleach) with 1.6 gal. (6.0 l) of warm water.

### c) Cleaning and Sanitizing Procedure

- 1) Move the control switch to the "OFF" position, then turn off the power supply.
- 2) Remove the front and top panels, then move the power switch to the "OFF" position.
- 3) Remove the storage bin cover.
- 4) Remove the motor bracket thumbscrews, first from the vertical plane and then from the horizontal plane. While holding on to the corresponding agitator or auger, move the agitating motor or the dispense motor towards you. Remove the agitator and the dispense auger from the storage bin. See Fig. 5.
- 5) Remove the bin control assembly. See Fig. 6.
- 6) Remove the snap pin, shaft, and actuator.
- 7) Remove spout B, spout A, and their gaskets.

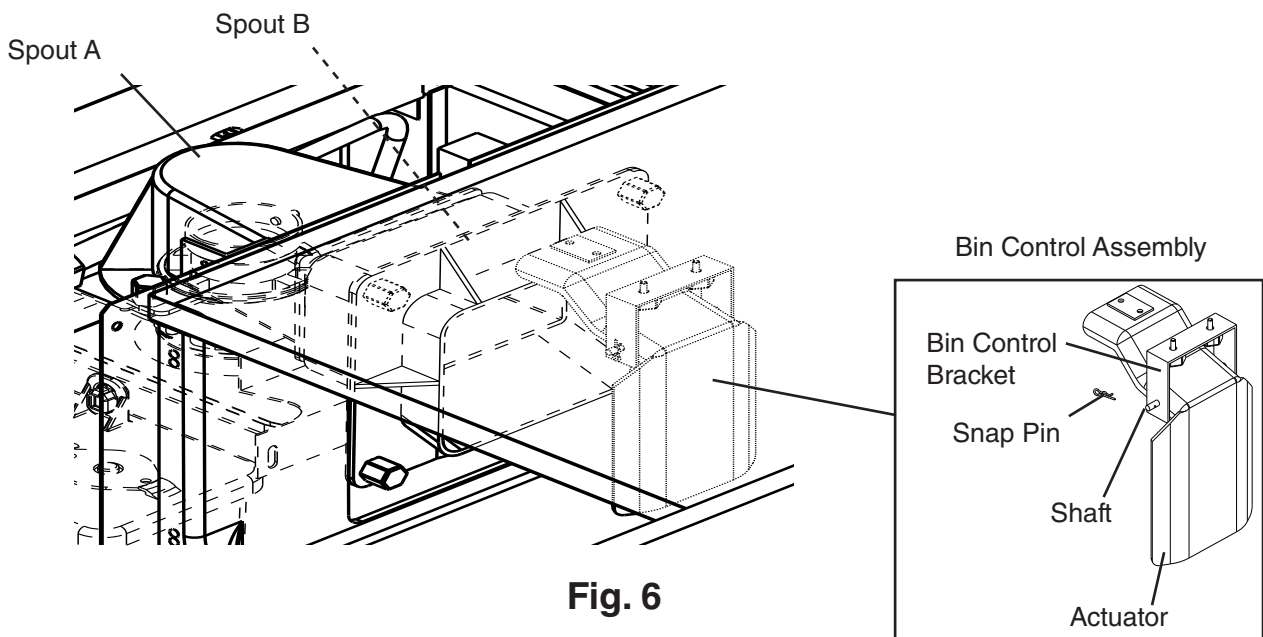

**Fig. 6**

- 8) Remove the spout cover, ice dispense spout, and water dispense nozzle. See Fig. 7.
- 9) Immerse the agitator, dispense auger, and parts removed in steps 5 through 8 in the cleaning solution and then in the sanitizing solution for 15 minutes each. Rinse the parts thoroughly with clean water. On Opti-Serve models (-OS), wipe the optical sensors with cleaning solution and then with a clean, damp cloth.
- 10) Wipe the shutter located above the ice dispense spout thoroughly with a clean cloth.
- 11) Reassemble the bin control assembly and replace all parts in the reverse order of which they were removed.
- 12) Pour warm water into the storage bin and melt any remaining ice. Clean the storage bin liner and the storage bin cover using a neutral cleaner. Rinse thoroughly after cleaning. Replace the storage bin cover in its correct position.
- 13) Move the power switch to the "ON" position, then replace the panels in their correct positions. Turn on the power supply, then move the control switch to the "ICE" position to start the automatic icemaking process.

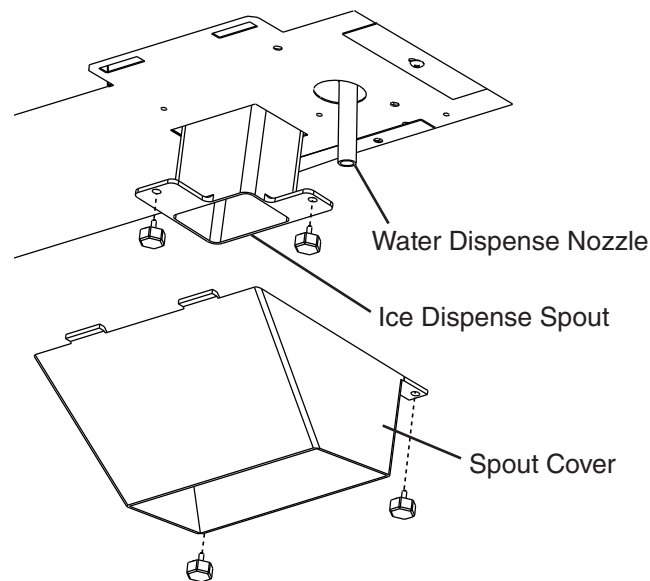

**Fig. 7**

## B. Maintenance

The maintenance schedule below is a guideline. More frequent maintenance may be required depending on water quality, the icemaker's environment, and local sanitation regulations.

### ⚠ WARNING

- Only qualified service technicians should service this icemaker.
- Move the control switch and the power switch to the "OFF" position and turn off the power supply before servicing. Lockout/Tagout to prevent the power supply from being turned back on inadvertently.

Maintenance Schedule		
Frequency	Area	Task
Every 2 Weeks	Air Filter	Inspect. Wash with warm water and neutral cleaner if dirty.
Monthly	External Water Filters	Check for proper pressure and change if necessary.
	Icemaker Exterior	Wipe down with a clean, soft cloth. Use a damp cloth containing a neutral cleaner to wipe off oil or dirt build up. Clean any chlorine staining (rust colored spots) using a non-abrasive cleaner like Zud or Bon Ami.
Every 6 Months	Icemaker and Storage Bin	Clean and sanitize per the cleaning and sanitizing instructions provided in this manual.
	Evaporator Condensate Drain Pan and Gear Motor Drain Pan	Wipe down with a clean cloth and warm water. Slowly pour one cup of sanitizing solution (prepare as outlined in the sanitizing instructions in this manual) into the evaporator condensate drain pan. Be careful not to overflow the pan. This solution will flow down to the gear motor drain pan and out the drain line to sanitize these areas. Repeat with a cup of clean water to rinse.
	Icemaker, Storage Bin, and Drip Tray Drains	Check to make sure they are clear.
Yearly	Inlet Water Valve and Drain Valve	Close the water supply line shut-off valve and drain the water system. Clean the inlet water valve screen and clean and inspect the drain valve.
	Water Hoses	Inspect the water hoses and clean/replace if necessary.
	Condenser	Inspect. Clean if necessary by using a brush or vacuum cleaner.
	Icemaker	Inspect for oil spots, loose components, fasteners, and wires.
	Upper Bearing (extruding head)	Check for wear using .02" round stock or pin gauge. Replace both upper bearing and lower bearing if wear exceeds factory recommendations. See "V.B. 1. Upper Bearing Wear Check".
After 3 Years, then Yearly	Upper Bearing (extruding head); Lower Bearing and O-Ring (lower housing); Mechanical Seal; Evaporator Cylinder; Auger	Inspect. Replace both upper bearing and lower bearing if wear exceeds factory recommendations. Replace the mechanical seal if the seal's contact surfaces are worn, cracked, or scratched.

## C. Preparing the Icemaker for Periods of Non-Use

<b>NOTICE</b>
---------------

When storing the icemaker for an extended time or in sub-freezing temperatures, follow the instructions below to prevent damage.
--

When the icemaker is not used for two or three days under normal conditions, it is sufficient to only move the control switch to the "OFF" position. When storing the icemaker for extended time or in sub-freezing temperatures, follow the instructions below.

- 1) Close the icemaker water supply line shut-off valve and open the icemaker water supply line drain valve.
- 2) Move the control switch to the "DRAIN" position. Allow the water system to drain for 5 minutes.
- 3) Move the dispense mode switch to the "CONTINUOUS" position, then dispense all of the ice from the storage bin.  
Note: Ice dispenses continuously for a maximum of 60 seconds per activation.
- 4) Attach a compressed air or carbon dioxide supply to the icemaker water supply line drain valve.
- 5) While engaging the water dispense switch, blow out the water dispense valve using the compressed air or carbon dioxide supply. After blowing out the water dispense valve, leave the compressed air or carbon dioxide supply flowing. Move the control switch to the "ICE" position to open the inlet water valve and briefly blow out the inlet water valve. After blowing out the inlet water valve, move the control switch to the "OFF" position.
- 6) Close the icemaker water supply line drain valve.
- 7) Turn off the power supply, then remove the front panel and move the power switch to the "OFF" position.
- 8) Remove the storage bin cover. Clean the storage bin liner and the storage bin cover using a neutral cleaner. Rinse thoroughly after cleaning. Replace the storage bin cover and the front panel in their correct positions.

---

## **VII. Disposal**

This icemaker contains refrigerant and must be disposed of in accordance with applicable national, state, and local codes and regulations. Refrigerant must be recovered by properly certified service personnel.