

Hoshizaki America, Inc.

Crescent Cube Icemaker / Dispenser

Model
DKM-500BAH



"A Superior Degree
of Reliability"

www.hoshizaki.com

Service Manual



Number: 73138
Issued: 9-20-2006

IMPORTANT

Only qualified service technicians should attempt to service or maintain this unit. No such service or maintenance should be undertaken until the technician has thoroughly read this Service Manual.

HOSHIZAKI provides this manual primarily to assist qualified service technicians in the service and maintenance of the unit.

Should the reader have any questions or concerns which have not been satisfactorily addressed, please call, write or send an e-mail message to the HOSHIZAKI Technical Support Department for assistance.

HOSHIZAKI AMERICA, INC.
618 Highway 74 South
Peachtree City, GA 30269

Attn: HOSHIZAKI Technical Support Department

Phone: 1-800-233-1940 Technical Service
(770) 487-2331

Fax: 1-800-843-1056
(770) 487-3360

E-mail: techsupport@hoshizaki.com

Web Site: www.hoshizaki.com

NOTE: To expedite assistance, all correspondence/communication MUST include the following information:

- Model Number
- Serial Number
- Complete and detailed explanation of the problem

Please review this manual. It should be read carefully before the unit is serviced or maintenance operations are performed. Only qualified service technicians should service and maintain the unit. This manual should be made available to the technician prior to service or maintenance.

CONTENTS

I. Specifications.....	5
II. General Information	6
A. Construction.....	6
B. Sequence of Operation	7
1. One Minute Fill Cycle	7
2. Initial Harvest Cycle	7
3. Freeze Cycle	7
4. Pump-Out Cycle	7
5. Normal Harvest Cycle	7
C. Control Board.....	9
1. Control Board Layout.....	10
2. Features	11
a) Maximum Water Supply Period – 6 minutes.....	11
b) Harvest Backup Timer and Freeze Timer	11
c) High Temperature Safety	11
d) Low Water Safety	11
e) High Voltage and Low Voltage Cut-outs	11
f) LED Lights and Audible Alarm Safeties.....	12
3. Controls and Adjustments	13
a) Default Dip Switch Settings	13
b) Harvest Control – Thermistor	13
c) Harvest Timer (dip switch 1 & 2).....	14
d) Pump-Out Timer (dip switch 3 & 4)	14
e) Pump-Out Frequency Control (dip switch 5 & 6)	15
f) Freeze Timer (dip switch 9 & 10).....	15
g) Bin Control	15
4. Bin Control Troubleshooting.....	16
a) Machine Will Not Start.....	16
b) Machine Will Not Shut Off	16
5. Control Board Check Procedure.....	16
6. Control Board Replacement	17
D. Switches.....	17
1. Control Switch	17
2. Service Switch.....	17
a) DRAIN	17
b) CIRCULATE	18
c) WASH.....	18

III. Technical Information	19
A. Water Circuit and Refrigeration Circuit.....	19
B. Wiring Diagram.....	20
C. Timing Chart	21
D. Performance Data	23
IV. Service Diagnosis.....	24
A. 10-Minute Diagnostic Procedure	24
B. Diagnostic Charts.....	25
1. Ice Making	25
a) No Ice Production.....	25
b) Evaporator is Frozen Up.....	28
c) Low Ice Production	29
d) Abnormal Ice	29
e) Other	30
2. Dispensing.....	30
V. Removal and Replacement of Components	32
A. Service for Refrigerant Lines	32
1. Refrigerant Recovery.....	32
2. Evacuation and Recharge (R-404A).....	32
B. Brazing	33
C. Removal and Replacement of Compressor	33
D. Removal and Replacement of Drier	34
E. Removal and Replacement of Expansion Valve.....	35
F. Removal and Replacement of Hot Gas Valve	35
G. Removal and Replacement of Evaporator	36
H. Removal and Replacement of Condenser	37
I. Removal and Replacement of Thermistor	38
J. Removal and Replacement of Fan Motor	38
K. Removal and Replacement of Inlet Water Valve	39
L. Removal and Replacement of Pump Motor.....	39
M. Removal and Replacement of Spray Tubes.....	40
N. Removal and Replacement of Gear Motor	40
O. Removal and Replacement of Dispense Switch	41
P. Removal and Replacement of Solenoid	41
VI. Cleaning and Maintenance Instructions	42
A. Cleaning Instructions	42
1. Cleaning Procedure – Icemaker	42
2. Sanitizing Procedure – Icemaker.....	43
3. Cleaning Procedure – Bin.....	44
4. Sanitizing Procedure – Bin	44
B. Maintenance Instructions	45
1. Exterior Panels	45
2. Air Filters	45
3. Condenser	45
C. Preparing the Icemaker for Long Storage	45

I. Specifications

A. DKM-500BAH

AC SUPPLY VOLTAGE	115/60/1				
AMPERAGE	13.3 A (5 Min. Freeze AT 104°F / WT 80°F)				
MINIMUM CIRCUIT AMPACITY	15 A				
MAXIMUM FUSE SIZE	15 A				
APPROXIMATE ICE PRODUCTION PER 24 HR.	Ambient Temp.(°F)	WATER TEMP. (°F)			
lbs./day (kg/day)		50	70	90	
Reference without *marks		70	*466 (211)	448 (203)	420 (191)
		80	453 (205)	425 (193)	395 (179)
		90	448 (203)	*406 (184)	376 (170)
	100	390 (177)	399 (181)	*348 (158)	
SHAPE OF ICE	Crescent Cube				
ICE PRODUCTION PER CYCLE	7.2 lbs. (3.2 kg) 360 pcs.				
APPROXIMATE STORAGE CAPACITY	200 lbs (91 Kg)				
APPROXIMATE ICE DISPENSING SPEED	13 lbs/min (6 kg/min)				
ELECTRIC & WATER CONSUMPTION	90/70°F	70/50°F			
ELECTRIC W (kWH/100 lbs.)	1150 (6.8)	1049 (5.4)			
WATER gal./24HR (gal./100 lbs.)	66 (16.3)	110 (23.6)			
EXTERIOR DIMENSIONS (WxDxH)	30" x 28" x 77" With 6" Flanged Legs				
EXTERIOR FINISH	Stainless Steel, Galvanized Steel (Rear)				
INTERIOR FINISH	Polyethylene 1 pc. Mold				
INSULATION	Polyurethane Foam				
WEIGHT	Net 385 lbs. (175 kg), Shipping 410 lbs. (186 kg)				
CONNECTIONS - ELECTRIC	Cord Connection				
- WATER SUPPLY	Inlet 1/2" FPT				
- DRAIN	Outlet 3/4" FPT x 2				
CUBE CONTROL SYSTEM	Float Switch				
HARVESTING CONTROL SYSTEM	Hot Gas and Water, Thermistor and Timer				
ICE MAKING WATER CONTROL	Timer Controlled. Overflow				
COOLING WATER CONTROL	N/A				
BIN CONTROL SYSTEM	Proximity Switch with Delay				
COMPRESSOR	Hermetic, Model RS55C2E-CAA-219				
CONDENSER	Air-cooled, Fin and tube type				
EVAPORATOR	Vertical type, Stainless Steel and Copper				
REFRIGERANT CONTROL	Thermostatic Expansion Valve				
REFRIGERANT CHARGE	R-404A, 2lbs (907g)				
DESIGN PRESSURE	High 467 PSIG, Low 170 PSIG				
P.C. BOARD CIRCUIT PROTECTION	High Voltage Cut-out (Internal)				
COMPRESSOR PROTECTION	Auto-reset Overload Protector (Internal)				
REFRIGERANT CIRCUIT PROTECTION	Auto-reset High Pressure Control Switch				
LOW WATER PROTECTION	Float Switch				
ACCESSORIES -SUPPLIED	N/A				
OPERATING CONDITIONS	VOLTAGE RANGE	104 - 127 V			
	AMBIENT TEMP.	45 -100° F			
	WATER SUPPLY TEMP.	45 - 90° F			
	WATER SUPPLY PRESSURE	10 - 113 PSIG			

Note: We reserve the right to make changes in specifications and design without prior notice.

II. General Information

A. Construction

1. DKM-500BAH

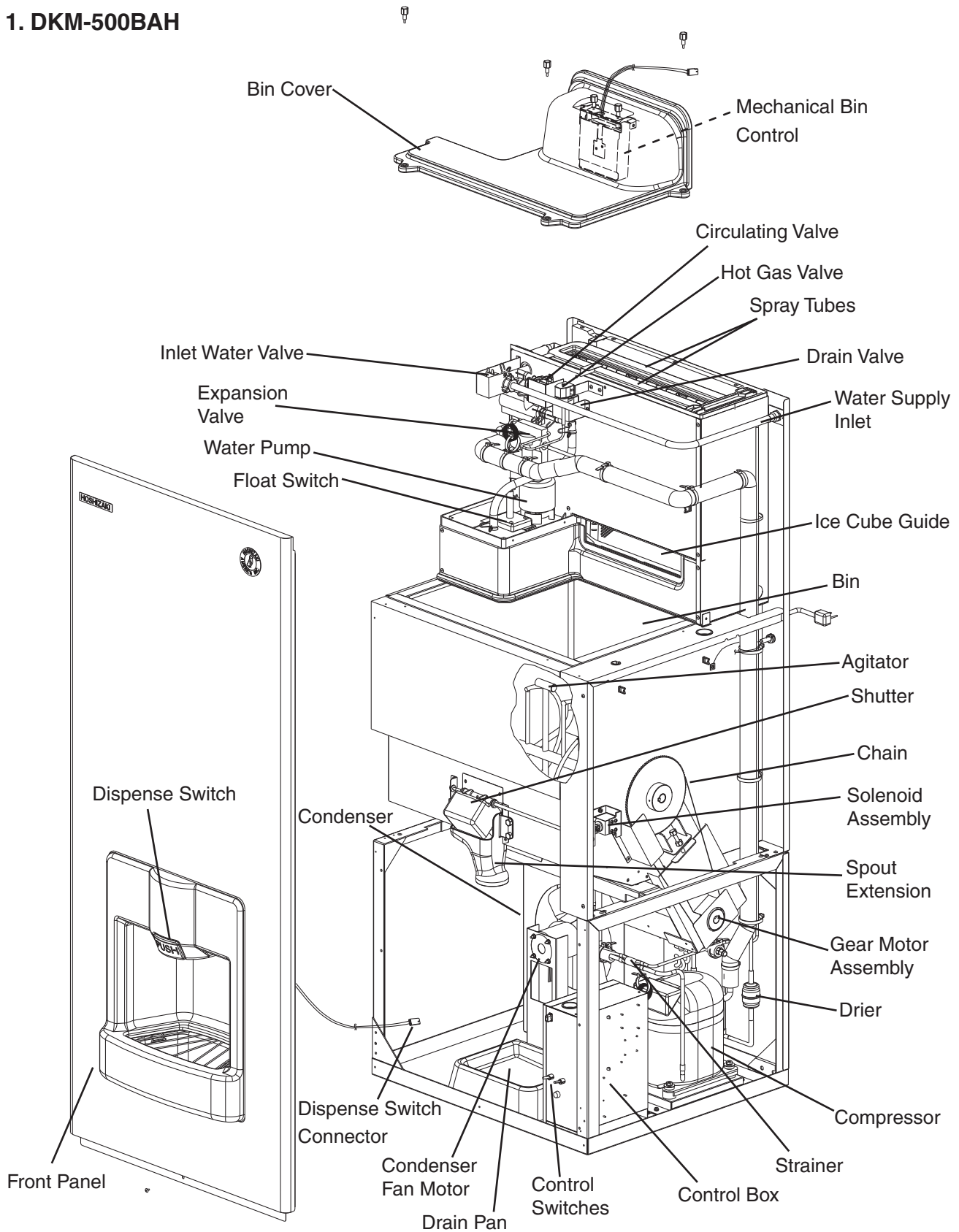

B. Sequence of Operation

The steps in the sequence are as outlined below. When power is supplied, a 5 second delay occurs at startup. Note that the order of the LEDs from the outer edge of the board is 1, 4, 3, 2.

1. One Minute Fill Cycle

LED 4 is on. WV opens and the fill period begins. After 1 minute, the board checks for a closed F/S. If F/S is closed, the harvest cycle begins. If not, the unit will not start without adequate water in the sump. This serves as a low water safety to protect the water pump. WV will remain energized through additional 1 minute cycles until water enters the sump and F/S closes.

2. Initial Harvest Cycle

LEDs 1, 4, and 2 are on. WV remains open, Comp energizes, HGV opens, and harvest begins. As the evaporator warms, the thermistor located on the suction line checks for a 48°F (9°C) temperature. When 48°F (9°C) is reached, a 3.9 kΩ signal turns the harvest over to the adjustable harvest timer which is factory set for normal conditions. The timer has settings of 60, 90, 120, and 180 seconds (dip switch 1 & 2). When the harvest timer completes its count down, the harvest cycle is complete and the freeze cycle starts. The minimum total time allowed by the board for a complete harvest cycle is 2 minutes.

3. Freeze Cycle

LED 1 is on. Comp continues to run, PM and FMS energize, HGV and WV close and the freeze cycle starts. For the first 5 minutes the control board will not accept a signal from F/S. This 5 minute minimum freeze acts as a short cycle protection. At the end of 5 minutes, F/S assumes control. As ice builds on the evaporator the water level in the sump lowers. The freeze continues until F/S opens and terminates ice production.

4. Pump-Out Cycle

LEDs 1, 3, and 2 are on. Comp continues to run, HGV opens, and FMS de-energizes. PM stops for 2 seconds. SR energizes, restarting PM and taking water from the sump and forcing it to go through DV and down the drain. When the pump-out timer stops counting, the pump out is complete.

Pump out always occurs on the 2nd harvest after startup. Then, depending on the control board setting, pump out occurs every cycle, or every 2nd, 5th or 10th cycle (dip switch 5 & 6).

5. Normal Harvest Cycle

LEDs 1, 4, and 2 are on. Comp continues to run, HGV remains open and WV opens. As the evaporator warms, the thermistor reaches 48°F (9°C). The control board then receives the thermistor's 3.9 kΩ signal and starts the harvest timer. The water valve is open during harvest for a maximum of 6 minutes or the length of harvest, whichever is shorter. When the harvest timer completes its count down, the harvest cycle is complete and the next freeze cycle starts.

Note: The unit continues to cycle through 3, 4 and 5 sequence until the bin control is activated (within first 5 minutes of freeze) and shuts the unit down.

Legend: **Comp**—compressor; **DV**—Drain Valve; **FMS**—self-contained fan motor; **F/S**—float switch; **HGV**—hot gas valve; **PM**—pump motor; **SR**—Service Relay; **WV**—inlet water valve

DKM-500BAH Sequence Flow Chart and Component Operation

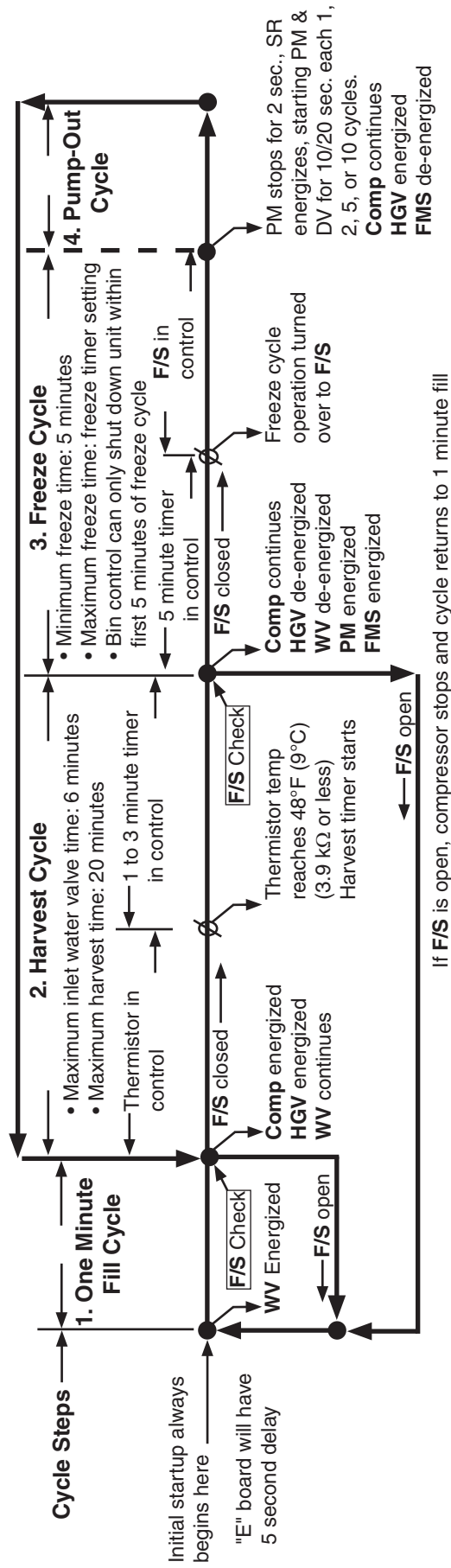

Legend: Comp—compressor; DV—drain valve; FMS—self-contained fan motor; F/S—float switch; HG—hot gas valve; PM—pump motor; SR—service relay; WV—inlet water valve

C. Control Board

- A HOSHIZAKI exclusive solid-state control is employed in the DKM-500BAH Crescent Cube Ice maker / Dispenser.
- All units are pretested and factory-adjusted.

CAUTION

1. Fragile, handle very carefully.
2. A control board contains integrated circuits, which are susceptible to failure due to static discharge. It is especially important to touch the metal part of the unit when handling or replacing the board.
3. Do not touch the electronic devices on the board or the back of the board to prevent damage to the board.
4. Do not change wiring and connections. Do not misconnect K3, K4 and K5, because the same connector is used for the thermistor, float switch and mechanical bin control.
5. Always replace the whole board assembly if it goes bad.
6. Do not short out power supply to test for voltage.

1. Control Board Layout

Control Products "E" Control Board

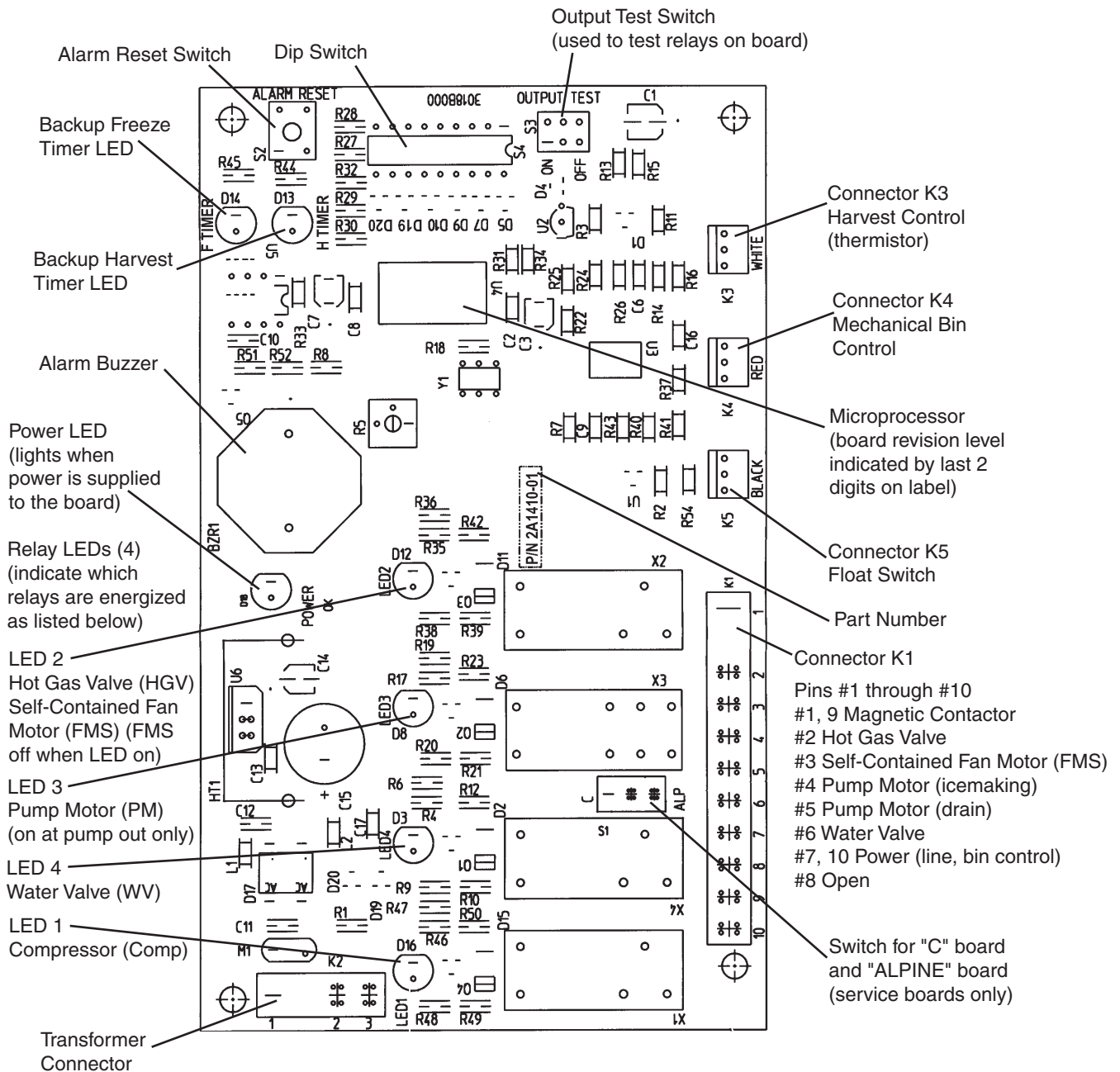

Control Board	
Part Number	2A1410-01 (factory); 2A1410-02 (service)
Type	HOS-001A (Control Products - 10 Pin)

2. Features

a) Maximum Water Supply Period – 6 minutes

Inlet water valve opening, in the harvest cycle, is limited by the harvest timer. The water valve cannot remain open longer than the maximum period. The water valve can close in less than six minutes if the harvest cycle is completed.

b) Harvest Backup Timer and Freeze Timer

The harvest backup timer shuts down the icemaker if, for two cycles in a row, the harvest cycle takes more than 20 minutes to complete. The control board will signal this problem using 2 beeps every 3 seconds.

The freeze timer shuts down the icemaker if, for two cycles in a row, the freeze cycle takes longer than the time specified to complete. The control board will signal this problem using 3 beeps every 3 seconds. The time is factory set using dip switches 9 & 10.

The reset button on the control board must be pressed with power on to reset either of these safeties.

c) High Temperature Safety

The temperature of the suction line in the refrigeration circuit is limited by the high temperature safety. This protects the unit from excessively high temperatures. If the evaporator temperature rises above $127 \pm 7^{\circ}\text{F}$ ($53 \pm 4^{\circ}\text{C}$), the thermistor operates the safety. This shuts down the circuit and the icemaker automatically stops.

The control board will signal this problem using 1 beep every 3 seconds. The reset button on the control board must be pressed with power on to reset the safety.

d) Low Water Safety

The control board checks the position of the float switch at the end of the initial one minute water fill cycle and at the end of each harvest cycle.

If the float switch is in the up position (electrical circuit closed), the control board changes to the ice making cycle. If the float switch is in the down position (electrical circuit open), the control board changes to additional one minute water fill cycles until water enters the sump and the float switch closes. When the float switch closes, the control board changes to the ice making cycle. The unit will not start without adequate water in the sump. This serves as a low water safety to protect the water pump.

e) High Voltage and Low Voltage Cut-outs

The maximum and minimum allowable supply voltages of this icemaker are limited by the high voltage and low voltage cut-outs.

If miswiring (especially on single phase 3 wire models) causes excessive voltage ($147\text{Vac} \pm 5\%$ or more) on the control board, the high voltage cut-out shuts down the circuit in 3 seconds and the icemaker automatically stops. The control board will signal this problem using 7 beeps every 3 seconds.

The icemaker also automatically stops in cases of insufficient voltage ($92\text{Vac} \pm 5\%$ or less). The control board will signal this problem using 6 beeps every 3 seconds.

When the proper supply voltage is resumed, the icemaker *automatically* starts running again.

f) LED Lights and Audible Alarm Safeties

The red LED indicates proper control voltage and will remain on unless a control voltage problem occurs. At startup a 5 second delay occurs while the board conducts an internal timer check. A short beep occurs when the power switch is turned OFF.

The green LEDs 1 through 4 energize and sequence from initial startup as listed in the table below. Note that the order of the LEDs from the outer edge of the board is 1, 4, 3, 2. For more information, see "II.B. Sequence of Operation."

Sequence Step	LED	Energized Components	Time LEDs are On		
			Min.	Max.	Avg.
1 Minute Fill Cycle	4	WV			60 seconds
Harvest Cycle	1, 4, and 2	WV, HGV, Comp	2 minutes	20 minutes	3 to 5 minutes
Freeze Cycle	1	Comp, PM, FMS	5 minutes	freeze timer setting	30 to 35 minutes
Pump Out	1, 3, and 2	Comp, HGV, PM, SR, DV	10 seconds	20 seconds	factory setting

The built in safeties shut down the unit and have alarms as follows:

No. of Beeps (every 3 sec.)	Type of Alarm	Notes
1	High Evaporator Temp. (temperature > 127°F) (53°C)	Check for harvest problem (stuck HGV or relay), hot water entering unit, or shorted thermistor.
2	Harvest Backup Timer (harvest > 20 min. for two cycles in a row)	Orange LED marked H TIMER lights up. Check for open thermistor, HGV not opening, TXV leaking by, low charge, or inefficient compressor.
3	Freeze Timer (freeze > specified setting for two cycles in a row) Timer is factory set using dip switches 9 & 10	Yellow LED marked F TIMER lights up. Check for F/S stuck closed (up), WV leaking by, HGV leaking by, TXV not feeding properly, low charge, or inefficient compressor.
4	Short Circuit (between the K4 connection on the control board and the bin control)	Resistor wire harness shorted. Check and replace wire harness if necessary.
5	Open Circuit (between the K4 connection on the control board and the bin control)	Resistor wire harness circuit open or control board open. Check and replace component if necessary.

To manually reset the above safeties, press the alarm reset button with the power supply on.

No. of Beeps (every 3 sec.)	Type of Alarm	Notes
6	Low Voltage (92Vac \pm 5% or less)	Red LED will turn off if voltage protection operates.
7	High Voltage (147Vac \pm 5% or more)	The control voltage safeties automatically reset when voltage is corrected.

Legend: **Comp**—compressor; **DV**—Drain Valve; **FMS**—self-contained fan motor; **F/S**—float switch; **HGV**—hot gas valve; **PM**—pump motor; **SR**—Service Relay; **TXV**—thermostatic expansion valve; **WV**—inlet water valve

3. Controls and Adjustments

a) Default Dip Switch Settings

The dip switch is factory-adjusted to the following positions:

Dip Switch No.	1	2	3	4	5	6	7	8	9	10
DKM-500BAH	ON	OFF	OFF	OFF	ON	ON	ON	OFF	OFF	ON

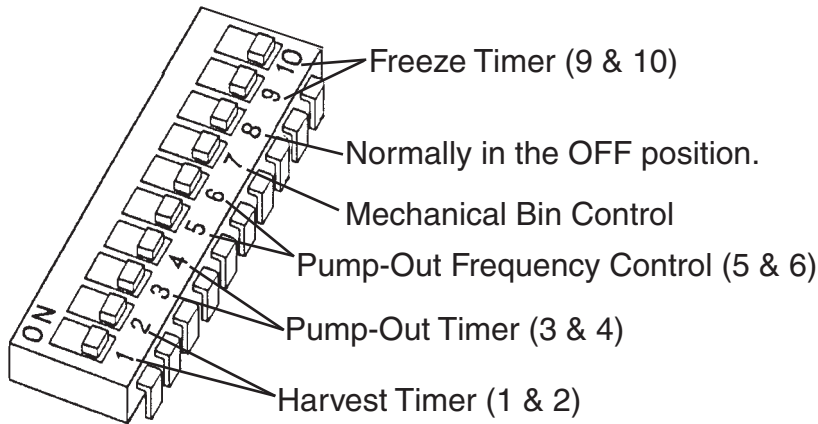

b) Harvest Control – Thermistor

A thermistor (semiconductor) is used for a harvest control sensor. The resistance varies depending on the suction line temperatures. The thermistor detects the temperature of the evaporator outlet to start the harvest timer. No adjustment is required. If necessary, check for resistance between thermistor leads, and visually check the thermistor mounting, located on the suction line next to the evaporator outlet.

Temperature (°F)	Temperature (°C)	Resistance (k Ω)
0	-18	14.401
10	-12	10.613
32	0	6.000
50	10	3.871
70	21	2.474
90	32	1.633

Check a thermistor for resistance by using the following procedure:

- 1) Disconnect the connector K3 on the board.
- 2) Remove the thermistor. See "V.H. Removal and Replacement of Thermistor."
- 3) Immerse the thermistor sensor portion in a glass containing ice and water for 2 or 3 minutes.
- 4) Verify the temperature of the glass, then check for resistance between thermistor leads. See the table above for temperature and resistance values. Normal reading is within 3.5 to 7 kΩ. Replace the thermistor if it exceeds the normal reading.

c) Harvest Timer (dip switch 1 & 2)

The harvest timer starts counting when the thermistor reads 48°F (9°C) at the evaporator outlet.

No adjustment is required under normal use, as the harvest timer is adjusted to the suitable position. However, a setting longer than the factory setting may be advised in cases where the flush provided at harvest needs to be prolonged for extra cleaning. Before changing this setting, call the HOSHIZAKI Technical Support Department at 1-800-233-1940 for recommendations. Keep in mind that setting the harvest timer to a longer setting will decrease 24 hour production.

Dip Switch Setting		Time (seconds)
No. 1	No. 2	
OFF	OFF	60
ON	OFF	90
OFF	ON	120
ON	ON	180

d) Pump-Out Timer (dip switch 3 & 4)

When a freeze cycle is completed, the pump motor stops, and the icemaker resumes operation in 2 seconds. Then, during cycles when a pump out is called for, the pump motor drains the water tank for the time determined by the pump-out timer. The pump-out timer also acts in place of the harvest timer during cycles with a pump out.

The pump-out timer is factory-adjusted, and no adjustment is required.

Dip Switch Setting		Time (seconds)	
No. 3	No. 4	T1	T2
OFF	OFF	10	150
ON	OFF	10	180
OFF	ON	10	120
ON	ON	20	180

T1: Time to drain the water tank

T2: Harvest timer at pump out

Pump out always occurs on the 2nd harvest after startup. Then, depending on the pump-out frequency control setting (dip switch 5 & 6), pump out occurs every cycle, or every 2nd, 5th or 10th cycle.

e) Pump-Out Frequency Control (dip switch 5 & 6)

The pump motor drains the water tank at the frequency set by the pump-out frequency control.

The pump-out frequency control is factory-adjusted to drain the water tank every 10 cycles, and no adjustment is required. However, where water quality is bad and the icemaker needs a pump drain more often, the pump-out frequency can be adjusted as shown in the table below.

Dip Switch Setting		Frequency
No. 5	No. 6	
OFF	OFF	every cycle
ON	OFF	every 2 cycles
OFF	ON	every 5 cycles
ON	ON	every 10 cycles

f) Freeze Timer (dip switch 9 & 10)

CAUTION

Adjust to proper specification, or the unit may not operate correctly.

The freeze timer setting determines the maximum allowed freeze time to prevent possible freeze-up issues. Upon termination of freeze timer, machine initiates the harvest cycle. After 2 consecutive timer terminations, machine will shut down, possibly indicating a problem.

The freeze timer is factory adjusted and no adjustment is required.

Dip Switch Setting		Time (minutes)
No. 9	No. 10	
OFF	OFF	60
OFF	ON	50
ON	OFF	70
ON	ON	60

g) Bin Control

CAUTION

Dip Switch No. 7 must be set to the ON position. If No. 7 is set to the OFF position, the machine will run continuously, causing a freeze-up condition.

This machine uses a lever-actuated proximity switch (mechanical bin control) to control the ice level in the storage bin. No adjustment is required. The bin control is factory-adjusted.

(1) Explanation of Operation

A resistor wire harness connects the bin control to the K4 connector on the control board. When the bin control is calling for ice (proximity switch closed), a 7.9 KΩ reading is sent to the control board to continue operation. When the bin control is activated in the bin full position (proximity switch open), a 15.8 KΩ signal is sent to the control board to

shut down the unit. However, to prevent incomplete batches of ice from forming on the evaporator, the control board will only shut down the machine within the first 5 minutes of the freeze cycle. If ice pushes the lever in after the first five minutes of the freeze cycle, the control board will allow the machine to complete the freeze cycle and the following harvest cycle before shutting down the machine.

Dip switch number 7 must be in the ON position for the control board to receive input from the bin control.

4. Bin Control Troubleshooting

a) Machine Will Not Start

- 1) Move dip switch no. 7 to the OFF position. If the machine starts up within a few seconds, the bin control is the likely problem. If the machine does not start up, refer to section "IV. Service Diagnosis" to verify that non-bin control related issues are resolved.
- 2) Check to make sure shipping tape has been removed and the wires are connected properly.
- 3) Check to make sure no obstruction prevents the lever from moving to the bin empty position.
- 4) Check proximity switch continuity to make sure it is not stuck open.

b) Machine Will Not Shut Off

- 1) Refer to Section "IV. Service Diagnosis" to verify that non-bin control related issues are resolved.
- 2) Dip switch no. 7 should be in the ON position. If the switch is in the OFF position, the control board will not receive input from the bin control.
- 3) Check to make sure no obstruction prevents the lever from moving to the bin full position.
- 4) Push the lever in within the first 5 minutes of the freeze cycle. If the machine does not shut off, check the resistance values of the resistor wire harness. You should read approximately 15.8 K Ω between the black terminal and the red terminal that connect to the K4 connector on the control board when the lever is in the bin full position (proximity switch open). If this reads approximately 7.9 K Ω , the resistors may be miswired or the proximity switch may be stuck closed. Switch the black and white wires in the terminal housing or order a replacement wire harness. If this does not resolve the problem, replace the bin control assembly.

5. Control Board Check Procedure

Before replacing a control board that does not show a visible defect and that you suspect is bad, always conduct the following check procedure. This procedure will help you verify your diagnosis.

- 1) Check the dip switch settings to assure that #3, 4, 7, 8, 9, & 10 are in the factory default position. Output test switch S3 should be OFF. Switches 1, 2, 5, & 6 are cleaning adjustments and the settings are flexible.
- 2) Turn the control switch to ICE and check for proper control voltage. If the red LED is ON, the control voltage is good. If the red LED is OFF, check the control transformer circuit.

- 3) Check the 115 volt input at the 10-pin connector. Check the brown wire at pin #10 to a white neutral wire for 115 volts. (Always choose a white neutral wire to establish a good neutral connection when checking voltages.) A jumper also feeds 115 volts into pin #7. If no voltage is present, check the 115 volt supply circuit.
- 4) The output test switch S3 provides a relay sequence test. With the control switch in the OFF position, place S3 ON and then move the control switch to the ICE position. The correct lighting sequence should be none, 2, 3, 4, 1, and 4, normal sequence every 5 seconds. Components (e.g., the compressor) will cycle during the test. Note that the order of the relays from the outer edge of the board is 1, 4, 3, 2.
Note: If the LEDs light in a different sequence or the 5-second interval does not occur, the control board is bad and should be replaced.
- 5) After checking the sequence, place S3 back in the OFF position. The S3 switch must remain in the OFF position during normal operation. This completes the output test and the unit is now in the 1 minute fill cycle.

6. Control Board Replacement

The application switch located between relay X3 & X4 must be set to match the original board application. Place this switch in the ALP position if there is no white wire supplied to the K1 connector. If there is a white wire, place the switch in the C position. If this switch is placed in the wrong position either the compressor contactor will remain energized with the control switch OFF or the unit will not start.

The dip switches should be adjusted to the factory default settings as outlined in this manual. 8 must remain in the OFF position.

D. Switches

Two control switches are used to control operation. These switches are referred to as the "control switch" and the "service switch" and are located on the control box.

1. Control Switch

The control switch has three positions: OFF for power off; ICE for icemaking, and SERVICE to activate the service switch.

2. Service Switch

When the control switch is in the SERVICE position, the control switch supplies power to the service switch and the machine is in service mode. The service switch has three positions: DRAIN, CIRCULATE, and WASH. See the information below for details of each function.

Note:

1. When the service switch is activated, power is supplied to the water pump in all three positions.
2. When the control switch is in the OFF position or in the ICE position, the service switch has no power and can be left in any position.

a) DRAIN

This model utilizes a pump-out drain system. When the service switch is active and placed in the DRAIN position, power is supplied to the pump, service relay and drain valve.

b) CIRCULATE

When the service switch is active and placed in the CIRCULATE position, power is supplied to the pump only. This operation can be used to circulate cleaner for extended periods of time over the outside surface of the evaporator.

c) WASH

This model utilizes a solenoid operated cleaning (bypass) valve. When the service switch is active and placed in the WASH position, power is supplied to the pump and the cleaning valve. This cleans both the inside and outside of the evaporator plate assembly.

III. Technical Information

A. Water Circuit and Refrigeration Circuit

1. DKM-500BAH

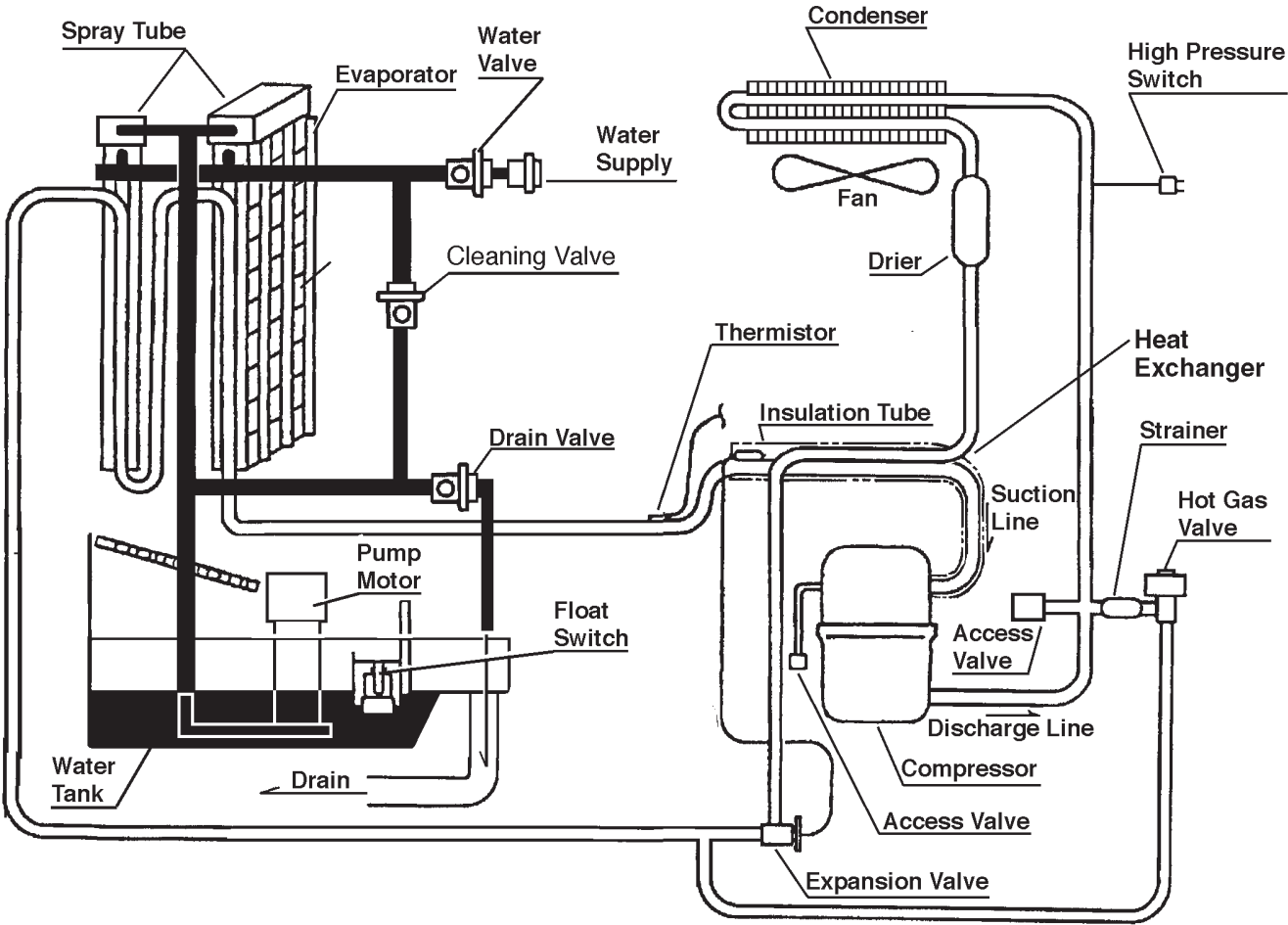

== Refrigerant Circuit
 == Water Circuit

B. Wiring Diagram

1. DKM-500BAH

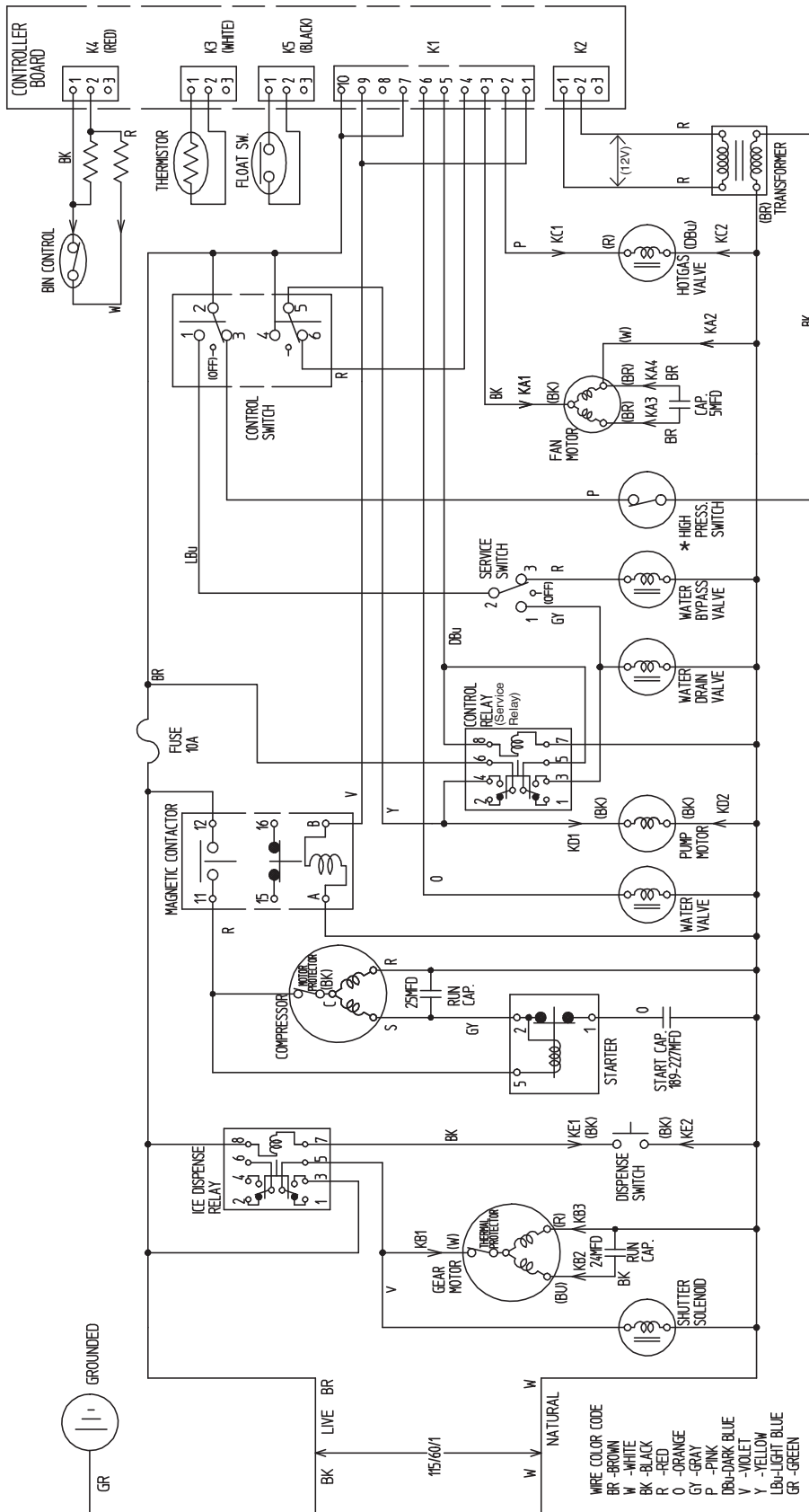

DIP SWITCH SETTING

MODEL	1	2	3	4	5	6	7	8	9	10
DKM-500BAH	ON	OFF	OFF	OFF	ON	ON	ON	OFF	OFF	ON

* Pressure Switch		
Cut-out	412.5 PSIG	
Cut-in	327±21.3 PSIG	

C. Timing Chart

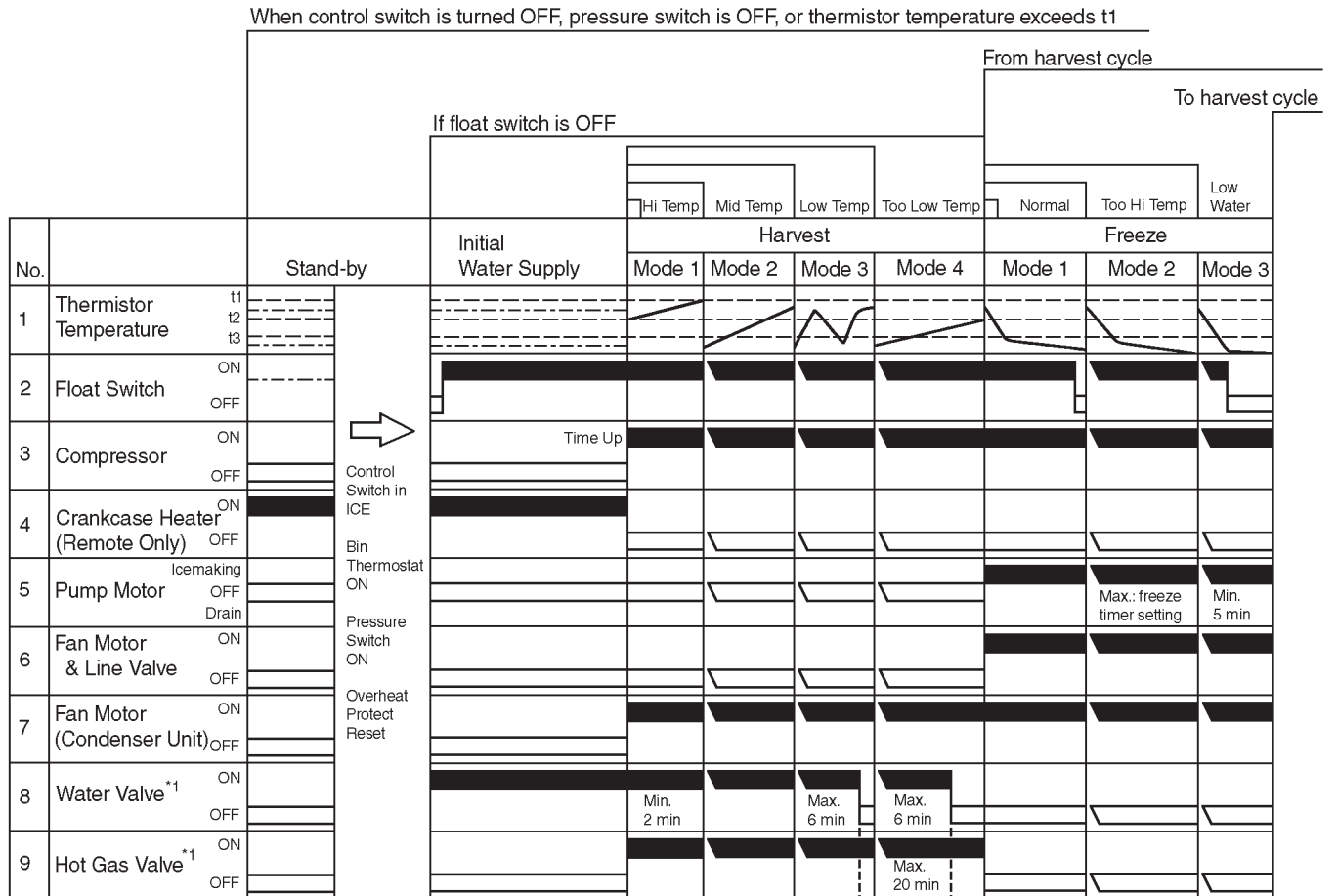

*1 The icemaker does not complete a defrost cycle in the first 2 or 3 minutes. See "II.C.3. Controls and Adjustments."

To stand-by cycle (When control switch is turned OFF, pressure switch is OFF, or thermistor temperature exceeds t1)

To freeze cycle

From freeze cycle

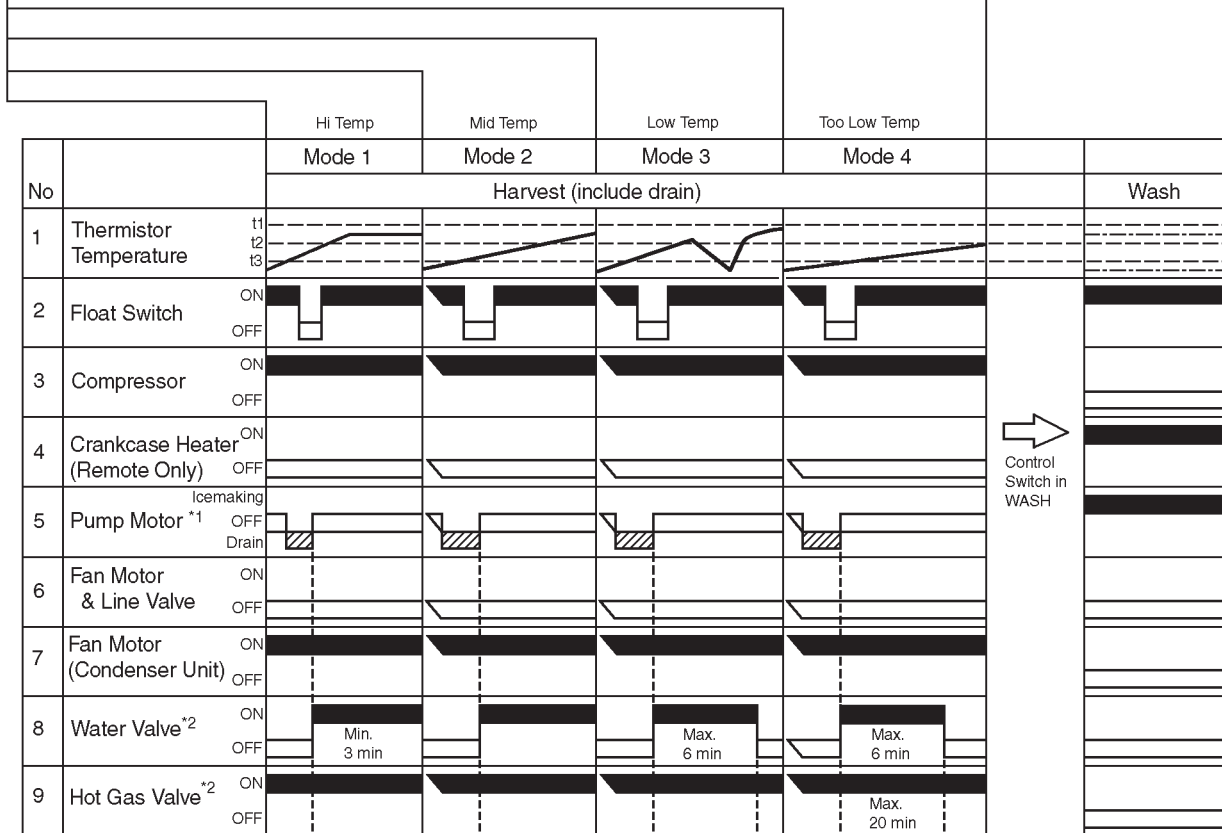

*1 The pump motor waits for 2 seconds before starting a drain cycle. See "II.C.3. Controls and Adjustments."

*2 The icemaker does not complete a defrost cycle in the first 2 or 3 minutes. See "II.C.3. Controls and Adjustments."

D. Performance Data

1. DKM-500BAH

APPROXIMATE ICE PRODUCTION PER 24 HR.	AMBIENT TEMP. (°F/°C)	WATER TEMP. (°F/°C)					
		50/10		70/21		90/32	
	70/21	466	<u>211</u>	448	<u>203</u>	420	<u>191</u>
	80/27	453	<u>205</u>	425	<u>193</u>	395	<u>179</u>
	90/32	448	<u>203</u>	406	<u>184</u>	376	<u>170</u>
lbs./day <u>kg./day</u>	100/38	390	<u>177</u>	399	<u>181</u>	348	<u>158</u>
APPROXIMATE ELECTRIC CONSUMPTION	70/21	1049		1078		1103	
	80/27	1071		1117		1133	
	90/32	1078		1150		1170	
watts	100/38	1100		1155		1189	
APPROXIMATE WATER CONSUMPTION PER 24 HR.	70/21	110	<u>0.42</u>	97	<u>0.37</u>	88	<u>0.33</u>
	80/27	100	<u>0.38</u>	80	<u>0.30</u>	75	<u>0.29</u>
	90/32	97	<u>0.37</u>	66	<u>0.25</u>	59	<u>0.22</u>
gal./day <u>m³/day</u>	100/38	144	<u>0.55</u>	65	<u>0.24</u>	53	<u>0.20</u>
FREEZING CYCLE TIME	70/21	19		19		21	
	80/27	19		21		23	
	90/32	19		22		24	
min.	100/38	23		22		26	
HARVEST CYCLE TIME	70/21	3.9		3.3		3.1	
	80/27	3.5		2.6		2.7	
	90/32	3.3		2.0		2.0	
min.	100/38	2.6		2.0		2.0	
HEAD PRESSURE	70/21	262	<u>18.4</u>	282	<u>19.8</u>	305	<u>21.5</u>
	80/27	277	<u>19.5</u>	308	<u>21.7</u>	329	<u>23.2</u>
	90/32	282	<u>19.8</u>	330	<u>23.2</u>	353	<u>24.8</u>
PSIG <u>kg/cm²G</u>	100/38	284	<u>20.0</u>	335	<u>23.6</u>	374	<u>26.3</u>
SUCTION PRESSURE	70/21	56	<u>3.9</u>	57	<u>4.0</u>	58	<u>4.1</u>
	80/27	57	<u>4.0</u>	58	<u>4.1</u>	60	<u>4.2</u>
	90/32	57	<u>4.0</u>	59	<u>4.2</u>	61	<u>4.3</u>
PSIG <u>kg/cm²G</u>	100/38	57	<u>4.0</u>	60	<u>4.2</u>	62	<u>4.4</u>

TOTAL HEAT OF REJECTION

8098 BTU/h [AT 90°F (32°C) / WT 70°F (21°C)]

Note:

1. Pressure data is recorded at 5 minutes into freezing cycle. The data not in **bold** should be used for reference only.
2. We reserve the right to make changes in specifications and design without prior notice.

IV. Service Diagnosis

A. 10-Minute Diagnostic Procedure

The 10 minute check out procedure is basically a sequence check which can be used at unit start-up or for system diagnosis. Using this check out procedure will allow you to diagnose electrical system and component failures in approximately 10 minutes under normal operating conditions of 70°F or warmer air and 50°F or warmer water temperatures. Before conducting a 10 minute checkout, check for correct installation, proper voltage per unit nameplate and adequate water supply. As you go through the procedure, check to assure the components energize and de-energize correctly. If not, those components and controls are suspect. Check for voltage at the 10-pin connector. Note that an activated bin control may have the machine off (bin control will only shut down the machine within the first 5 minutes of the freeze cycle).

- 1) Turn power OFF and access the control box.
- 2) Turn power ON and place the control switch in ICE position. A 5 second delay occurs.
- 3) **One Minute Fill Cycle** – The inlet water valve is energized. After 1 minute, the control board checks the float switch. If the float switch is closed, the unit cycles to harvest. If closed, continue to step 4. If the float switch is open, the unit repeats the 1 minute fill cycle until water enters and the float switch closes (low water safety protection during initial start up and at the end of each harvest). **Diagnosis:** If the water valve does not open, check for no supply voltage at water valve terminals, bad coil, or plugged screen or external filter (no water flow). If unit fails to start harvest, check for open float switch or bad 1 minute timer in board.
- 4) **Initial Harvest Cycle** – Inlet water valve remains energized, contactor coil energizes to start the compressor, and the hot gas valve energizes. The evaporator warms and the thermistor senses 48°F (9°C). The control board then receives the thermistor's 3.9 kΩ signal and turns operation of harvest over to the harvest timer. The timer completes counting (1 to 3 minutes). The unit then cycles to freeze. **Diagnosis:** Check if compressor is running, hot gas valve is open, water valve still open. Average harvest cycle at factory setting is 2 to 3 minutes. How long does initial harvest last? 1.5 minutes after initial harvest begins, touch the compressor discharge line. Is it hot? If not check refrigerant pressures and compressor operation. If it is hot, touch the inlet line to the evaporator. Is it hot? If it is hot and the freeze cycle is not starting, check the harvest timer adjustment, the thermistor for open circuit, the discharge line temperature, compressor efficiency, and if the hot gas valve is fully open.
- 5) **Freeze Cycle** – Compressor remains energized, pump motor and fan motor energize. The inlet water valve and hot gas valve de-energize. The unit is held in freeze by a 5 minute short cycle protection timer. After 5 minutes, the freeze cycle operation is transferred to the float switch for freeze termination. During the first 5 minutes of freeze, confirm that the evaporator temperature drops. After 7 minutes in freeze, remove the black float switch lead from the K5 connector. The unit should immediately switch to the pump-out cycle. **Diagnosis:** If the evaporator is not cold, check to see if the hot gas valve is still open or if the expansion valve is not opening properly, if the water valve is continuing to fill the reservoir, if there are improper unit pressures, or an inoperative compressor. If the unit remains in freeze with the float switch removed, replace the board.

Note: Normal freeze cycle will last 20 to 40 minutes depending on model and

conditions. Cycle times and pressures should follow performance data provided in this manual.

6) **Pump-Out Cycle (10/20 second pump out)** – the compressor remains energized, the hot gas valve energizes, the fan motor de-energizes, the pump motor stops for 2 seconds. The service relay energizes, restarting the pump motor and taking water from the sump and forcing it to go through the drain valve and down the drain for 10/20 seconds. This removes contaminants from the water reservoir. Check for clear tubing at the drain valve housing and check the unit drain for water flow. **Diagnosis:** If the pump motor does not run, check the circuit, service relay and capacitor. Check for proper voltage. If water does not pump out, remove the drain valve and check/clean the valve assembly.

7) **Normal Harvest Cycle** – same as the initial harvest cycle – Return to step 4.
 Note: Unit continues to cycle until bin control is satisfied or power is switched OFF. (The pump out cycle can be adjusted to occur every cycle, or every 2, 5, or 10 cycles. The factory default is every 10 cycles.) The unit always restarts at the 1 minute fill cycle.

B. Diagnostic Charts

1. Ice Making

a) No Ice Production

Problem	Possible Cause	Remedy	
[1] The icemaker will not start.	a) Power Supply	1. OFF position.	1. Move to ON position.
		2. Loose connection.	2. Tighten.
		3. Bad contacts.	3. Check for continuity and replace.
		4. Voltage too high.	4. Check and get recommended voltage.
	b) Fuse (Inside fused disconnect, if any)	1. Blown.	1. Check for short circuit and replace.
	c) Control Switch	1. OFF position.	1. Move to ICE position.
		2. Bad contacts.	2. Check for continuity and replace.
	d) Bin Control See the information to the right and also see "II.C.4. Bin Control Troubleshooting."	1. Tripped with bin filled with ice.	1. Remove ice.
		2. Bad contacts (stuck open).	2. Check for continuity and replace.
		3. Resistor wire harness.	3. Check resistance. Should be approximately 7.9 K Ω when calling for ice (proximity switch closed).
	e) High Pressure Control	1. Bad contacts.	1. Check for continuity and replace.
		2. Dirty air filter or condenser.	2. Clean.
		3. Ambient temperature too warm.	3. Reduce temperature.

Problem	Possible Cause	Remedy	
		4. Refrigerant overcharged.	4. Recharge.
		5. Fan not operating.	5. See chart 1. a) [6]
		6. Refrigerant line or components plugged.	6. Clean and replace drier.
	f) Transformer	1. Coil winding opened or shorted.	1. Replace.
	g) Wiring to Control Board	1. Loose connections or open.	1. Check for continuity and replace.
	h) Thermistor	1. Leads shorted or opened and high temperature or harvest backup timer safety operates. (1 beep or 2 beep alarm)	1. See "II.C.3. Controls and Adjustments, b) Harvest Control."
	i) Hot Gas Valve	1. Continues to open in freeze cycle and freeze timer safety operates. (3 beep alarm)	1. Check for hot gas valve stuck open and replace.
	j) Water Supply Line	1. Water supply off and water supply cycle does not finish.	1. Check and get recommended pressure.
	k) Inlet Water Valve	1. Mesh filter or orifice gets clogged and water supply cycle does not finish.	1. Clean.
		2. Coil winding opened.	2. Replace.
		3. Wiring to water valve.	3. Check for loose connection or open, and replace.
	l) Control Board	1. Defective or in alarm.	1. See "II.C.5. Control Board Check Procedure."
	m) Control Switch	1. SERVICE position.	1. Move to ICE position.
2. Bad contacts.		2. Check and replace.	
[2] Water continues to be supplied, and the icemaker will not start.	a) Float Switch	1. Connector disconnected.	1. Place in position.
		2. Leads opened or defective switch.	2. Check and replace.
		3. Float does not move freely.	3. Clean or replace.
b) Control Board	1. Defective.	1. See "II.C.5. Control Board Check Procedure."	
[3] Compressor will not start or stops operating.	a) Magnetic Contactor	1. Bad contacts.	1. Check for continuity and replace.
		2. Coil winding opened.	2. Replace.
	b) Start Capacitor or Run Capacitor	1. Defective.	1. Replace.

Problem	Possible Cause	Remedy	
	c) Internal Overload Protector Open (check 1 through 3 to the right and d through f below)	1. Loose terminal.	1. Tighten or replace.
		2. Voltage.	2. Check and correct.
		3. Dirty condenser.	3. Clean.
	d) Starter	1. Bad contacts.	1. Check and replace.
		2. Coil winding opened.	2. Replace.
	e) Compressor	1. Wiring to compressor.	1. Check for loose connection or open, and replace.
		2. Defective.	2. Replace.
		3. Protector tripped.	3. Reduce temperature.
	f) Control Board	1. No power to contactor.	1. See "II.C.5. Control Board Check Procedure."
	[4] Water continues to be supplied in freeze cycle.	a) Inlet Water Valve	1. Diaphragm does not close.
b) Control Board		1. Defective.	1. See "II.C.5. Control Board Check Procedure."
[5] No water comes from spray tubes. Water pump will not start, or freeze cycle time is too short.	a) Water Supply Line	1. Water pressure too low and water level in water tank too low.	1. Check and get recommended pressure.
	b) Inlet Water Valve	1. Dirty mesh filter or orifice and water level in water tank too low.	1. Clean.
	c) Water System	1. Water leaks.	1. Check connections for water leaks, and replace.
		2. Clogged.	2. Clean.
	d) Pump Motor	1. Motor winding opened.	1. Replace.
		2. Bearing worn out.	2. Replace.
		3. Wiring to pump motor.	3. Check for loose connection or open, and replace.
		4. Defective capacitor.	4. Replace.
		5. Defective or bound impeller.	5. Replace and clean.
	e) Control Board	1. Defective.	1. See "II.C.5. Control Board Check Procedure."
[6] Fan motor will not start, or is not operating.	a) Fan Motor	1. Motor winding opened.	1. Replace.
		2. Bearing worn out.	2. Replace.
		3. Wiring to fan motor.	3. Check for loose connection or open, and replace.
		4. Defective capacitor.	4. Replace.
		5. Fan blade bound.	5. Check and replace.

Problem	Possible Cause	Remedy
	b) Control Board	1. Defective. 1. See "II.C.5. Control Board Check Procedure."
[7] All components run, but no ice is produced.	a) Refrigerant	1. Undercharged. 1. Check for leaks and recharge.
		2. Air or moisture trapped. 2. Replace drier and recharge.
	b) Compressor	1. Defective valve. 1. Replace.
	c) Hot Gas Valve	1. Continues to open in freeze cycle. 1. Check and replace.
	d) Inlet Water Valve	1. Water valve is wide open during freeze. 1. Check for water leaks with icemaker off.

b) Evaporator is Frozen Up

Problem	Possible Cause	Remedy
[1] Freeze cycle time is too long.	a) Float Switch	1. Leads short-circuit or defective switch. 1. Check and replace.
		2. Float does not move freely. 2. Clean or replace.
	b) Inlet Water Valve	1. Diaphragm does not close. 1. Check for water leaks with icemaker off.
	c) Control Board	1. Defective. 1. See "II.C.5. Control Board Check Procedure."
[2] All ice formed on evaporator does not fall into bin in harvest cycle.	a) Evaporator	1. Scaled up. 1. Clean.
	b) Water Supply Line	1. Water pressure too low. 1. Check and get recommended pressure.
	c) Water Filter System	1. Dirty/Restricted 1. Replace filter.
	d) Inlet Water Valve	1. Dirty mesh filter or orifice. 1. Clean.
		2. Diaphragm does not close. 2. Check for water leaks with icemaker off.
	e) Ambient and/or water temperature.	1. Too cool. 1. Increase temperature.
	f) Thermistor	1. Out of position or loose attachment. 1. See "V.H. Removal and Replacement of Thermistor."
g) Control Board	1. Harvest timer is set too short. 1. Adjust longer, referring to "II.C.3. Controls and Adjustments, c) Harvest Timer."	
	2. Defective. 2. See "II.C.5. Control Board Check Procedure."	
[3] Other	a) Spray Tubes	1. Clogged. 1. Clean
		2. Out of position. 2. Place in position.
	b) Water System	1. Dirty. 1. Clean.
	c) Refrigerant	1. Undercharged. 1. Check for leaks and recharge.

Problem	Possible Cause	Remedy	
	d) Expansion Valve	1. Bulb out of position or loose attachment.	1. Place in position.
		2. Defective.	2. Replace.
	e) Hot Gas Valve	1. Coil winding opened.	1. Replace.
		2. Plunger does not move.	2. Replace.
		3. Wiring to hot gas valve.	3. Check for loose connection or open, and replace.
	f) Ice Cube Guide	1. Out of position and ice trapped.	1. Place in position.
g) Water Supply Line	1. Too small; requires 3/8" OD line dedicated per machine.	1. Increase water line size.	
h) Water Filter	1. Flow rate too small.	1. Replace with filter that has larger flow rate.	

c) Low Ice Production

Problem	Possible Cause	Remedy
[1] Freeze cycle time is long.	a) See chart 1. a) [3] and check dirty air filter or condenser, ambient or water temperature, water pressure, and refrigerant charge.	
	b) See chart 1. b) [1] and check float switch, inlet water valve and control board.	
	c) Check pump, hot gas valve, expansion valve, refrigeration check valve, and compressor.	
[2] Harvest cycle time is long.	a) See chart 1. b) [2] and check control board, thermistor, evaporator, ambient and/or water temperature, water supply line, inlet water valve, and hot gas valve.	

d) Abnormal Ice

Problem	Possible Cause	Remedy	
[1] Small cubes.	a) Ice Cube Guide	1. Out of position. Circulated water falls into bin.	1. Place in position.
	b) See chart 1. a) [5] and check water supply line, inlet water valve, water system, pump motor, and control board.		
	c) Drain Valve	1. Dirty.	1. Clean.
[2] Cloudy or irregular cubes.	a) See chart 1. b) [1] and 1. b) [3], and check float switch, inlet water valve, control board, spray tubes, water system, refrigerant charge, and expansion valve.		
	b) Spray Guide	1. Dirty.	1. Clean.
	c) Water Quality	1. High hardness or contains impurities.	1. Install a water softener or filter.

e) Other

Problem	Possible Cause	Remedy
[1] Icemaker will not stop when bin is filled with ice.	a) Bin Control	See "II.C.4. Bin Control Troubleshooting."
	b) Control Board	1. Defective. 1. See "II.C.5. Control Board Check Procedure."
[2] Abnormal noise.	a) Pump Motor	1. Bearings worn out. 1. Replace
	b) Fan Motor	1. Bearings worn out. 1. Replace
		2. Fan blade deformed. 2. Replace fan blade.
		3. Fan blade does not move freely. 3. Replace.
	c) Compressor	1. Bearings worn out or cylinder valve broken. 1. Replace.
		2. Mounting pad out of position. 2. Reinstall.
d) Refrigerant Lines	1. Rub or touch other lines or surfaces. 1. Replace.	
[3] Ice in storage bin often melts.	a) Drain Line(s)	1. Plugged. 1. Clean.
	b) Icemaker and Bin	1. Drains not run separately. 1. Separate the drain lines.
	c) Ice Cube Guide	1. Out of position. Circulated water falls into bin. 1. Place in position.

2. Dispensing

Problem	Possible Cause	Remedy
[1] No ice dispensed.	a) Power Supply	1. OFF position. 1. Move to ON position.
		2. Loose connection. 2. Tighten.
		3. Bad contacts. 3. Check for continuity and replace.
		4. Voltage too high. 4. Check and get recommended voltage.
	b) Fuse (Inside Fused Disconnect, if any)	1. Blown. 1. Check for short circuit and replace.
	c) Dispense Switch	1. Connector from front panel not connected to control box. 1. Connect.
		2. Bad contacts. 2. Check for continuity and replace.
		3. Loose connection. 3. Tighten.
	d) Gear Motor	1. Thermal protector is tripped. 1. Allow to cool.
		2. Gear motor winding opened. 2. Replace.
		3. Bearing worn out. 3. Replace.

Problem	Possible Cause	Remedy		
		4. Wiring to gear motor.	4. Check for loose connection or open circuit, and replace wiring as needed.	
		5. Defective capacitor.	5. Replace.	
		6. Agitator rotates in reverse direction.	6. Check leads and reverse the connections.	
	e) Solenoid	1. Solenoid winding open.	1. Replace	
		2. Wiring to solenoid.	2. Check for loose connection or open circuit, and replace wiring as needed.	
		3. Overload due to loosening screws.	3. After tightening, apply thread sealant to the parts.	
	f) Mechanism	1. Chain out of position or loose.	1. Place in position or tighten.	
		2. Corrosion.	2. Apply oil.	
		3. Key of sprocket is not in position.	3. Place in position.	
		4. Bad alignment of sprocket.	4. Readjust.	
		5. Foreign matter interrupting agitator.	5. Remove foreign matter.	
	g) Ice Storage	1. No ice or little ice in storage bin.	1. Make ice.	
		2. Ice bridge or block formed.	2. Break with a poker.	
	[2] Abnormal noise.	a) Gear Motor or Gear Head	1. Bearing worn out.	1. Replace.
			2. Grease leaks.	2. Supply grease and replace O-ring.
b) Mechanism		1. Bad setting.	1. Apply oil and readjust.	
		2. Bad alignment of sprocket.	2. Readjust.	
		3. Foreign matter interrupting agitator.	3. Remove foreign matter.	
c) Solenoid		1. Overload due to loosening screws.	1. After tightening, apply thread sealant to the parts.	
		2. Foreign matter on plunger.	2. Clean.	

V. Removal and Replacement of Components

IMPORTANT

Ensure all components, fasteners and thumbscrews are securely in place after the equipment is serviced.

IMPORTANT

1. The Polyol Ester (POE) oils used in R-404A units can absorb moisture quickly. Therefore it is important to prevent moisture from entering the system when replacing or servicing parts.
2. Always install a new filter drier every time the sealed refrigeration system is opened.
3. Do not leave the system open for longer than 15 minutes when replacing or servicing parts.

A. Service for Refrigerant Lines

1. Refrigerant Recovery

The icemaker unit is provided with two refrigerant access valves—one on the low-side and one on the high-side line. Using proper refrigerant practices recover the refrigerant from the access valves and store it in an approved container. Do not discharge the refrigerant into the atmosphere.

2. Evacuation and Recharge (R-404A)

- 1) Attach charging hoses, a service manifold and a vacuum pump to the system. Be sure to connect charging hoses to both high and low-side access valves.

IMPORTANT

The vacuum level and vacuum pump may be the same as those for current refrigerants. However, the rubber hose and gauge manifold to be used for evacuation and refrigerant charge should be exclusively for POE oils.

- 2) Turn on the vacuum pump. Never allow the oil in the vacuum pump to flow backward.
- 3) Allow the vacuum pump to pull down to a 29.9" Hg vacuum. Evacuating period depends on pump capacity.
- 4) Close the low-side valve and high-side valve on the service manifold.
- 5) Disconnect the vacuum pump, and attach a refrigerant service cylinder to the high-side line. Remember to loosen the connection, and purge the air from the hose. See the nameplate for the required refrigerant charge. Hoshizaki recommends only virgin refrigerant or reclaimed refrigerant which meets ARI Standard No. 700-88 be used.
- 6) A liquid charge is recommended for charging an R-404A system. Invert the service cylinder. Open the high-side, service manifold valve.
- 7) Allow the system to charge with liquid until the pressures balance.

- 8) If necessary, add any remaining charge to the system through the low-side. Use a throttling valve or liquid dispensing device to add the remaining liquid charge through the low-side access port with the unit running.
- 9) Close the two refrigerant access valves, and disconnect the hoses and service manifold.
- 10) Cap the access valves to prevent a possible leak.

B. Brazing

DANGER

1. Refrigerant R-404A itself is not flammable at atmospheric pressure and temperatures up to 176°F (80°C).
2. Refrigerant R-404A itself is not explosive or poisonous. However, when exposed to high temperatures (open flames), R-404A can be decomposed to form hydrofluoric acid and carbonyl fluoride both of which are hazardous.
3. Always recover the refrigerant and store it in an approved container. Do not discharge the refrigerant into the atmosphere.
4. Do not use silver alloy or copper alloy containing arsenic.
5. Do not use R-404A as a mixture with pressurized air for leak testing. Refrigerant leaks can be detected by charging the unit with a little refrigerant, raising the pressure with nitrogen and using an electronic leak detector.

Note: Because the pipes in the evaporator case are specially coated to resist corrosion, it is important to make connections outside the evaporator case when possible. If it is necessary to braze inside the evaporator case, use sandpaper to remove the coating from the brazing connections before unbrazing the components.

C. Removal and Replacement of Compressor

IMPORTANT

Always install a new drier every time the sealed refrigeration system is opened.

Note: When replacing a compressor with a defective winding, be sure to install the new start capacitor and start relay supplied with the replacement compressor. Due to the ability of the POE oil in the compressor to absorb moisture quickly, the compressor must not be opened more than 15 minutes for replacement or service. Do not mix lubricants of different compressors even if both are charged with R-404A, except when they use the same lubricant.

- 1) Turn off the power supply.
- 2) Remove the panels. Be sure to disconnect the dispense switch connector from the control box when removing the front panel.
- 3) Recover the refrigerant and store it in an approved container.

- 4) Remove the terminal cover on the compressor, and disconnect the compressor wiring.
- 5) Remove the discharge and suction pipes using brazing equipment.
- 6) Remove the hold-down bolts, washers and rubber grommets.
- 7) Remove the compressor. Unpack the new compressor package.
- 8) Attach the rubber grommets of the prior compressor.
- 9) Place the compressor in position, and secure it using the bolts and washers.
- 10) Remove the drier, then place the new drier in position.
- 11) Remove plugs from the suction, discharge and process pipes.
- 12) Braze all fittings while purging with nitrogen gas flowing at a pressure of 3 to 4 PSIG.
- 13) Check for leaks using nitrogen gas (140 PSIG) and soap bubbles.
- 14) Evacuate the system, and charge it with refrigerant. See the nameplate for the required refrigerant charge.
- 15) Connect the terminals, and replace the terminal cover in its correct position.
- 16) Replace the panels in their correct positions.
- 17) Turn on the power supply.

D. Removal and Replacement of Drier

IMPORTANT

Always install a new drier every time the sealed refrigeration system is opened. Do not replace the drier until after all other repair or replacement has been made.

- 1) Turn off the power supply.
- 2) Remove the panels. Be sure to disconnect the dispense switch connector from the control box when removing the front panel.
- 3) Recover the refrigerant and store it in an approved container.
- 4) Remove the drier.
- 5) Install the new drier with the arrow on the drier in the direction of the refrigerant flow. Use nitrogen gas at a pressure of 3 to 4 PSIG when brazing the tubings.
- 6) Check for leaks using nitrogen gas (140 PSIG) and soap bubbles.
- 7) Evacuate the system, and charge it with refrigerant. See the nameplate for the required refrigerant charge.
- 8) Replace the panels in their correct positions.
- 9) Turn on the power supply.

E. Removal and Replacement of Expansion Valve

IMPORTANT

Sometimes moisture in the refrigeration circuit exceeds the drier capacity and freezes up at the expansion valve. Always install a new drier every time the sealed refrigeration system is opened. Do not replace the drier until after all other repair or replacement has been made.

- 1) Turn off the power.
- 2) Remove the panels. Be sure to disconnect the dispense switch connector from the control box when removing the front panel.
- 3) Recover the refrigerant and store it in an approved container.
- 4) Remove the insulation and the expansion valve bulb on the suction line.
- 5) Remove the expansion valve cover, and disconnect the expansion valve using brazing equipment.
- 6) Braze the new expansion valve with nitrogen gas flowing at the pressure of 3 to 4 PSIG.

WARNING

Always protect the valve body by using a damp cloth to prevent the valve from overheating. Do not braze with the valve body exceeding 250°F (121°C).

- 7) Install the new drier.
- 8) Check for leaks using nitrogen gas (140 PSIG) and soap bubbles.
- 9) Evacuate the system, and charge it with refrigerant. See the nameplate for the required refrigerant charge.
- 10) Attach the expansion valve bulb to the suction line in the same location as the previous bulb. The bulb should be at the 12 o'clock position on the tube. Be sure to secure the bulb with the clamp and holder and to insulate it.
- 11) Place the new set of expansion valve covers in position.
- 12) Replace the panels in their correct positions.
- 13) Turn on the power supply.

F. Removal and Replacement of Hot Gas Valve

IMPORTANT

1. Always use a copper tube of the same diameter and length when replacing the hot gas lines; otherwise the performance may be reduced.
2. Always install a new drier every time the sealed refrigeration system is opened. Do not replace the drier until after all other repair or replacement has been made.
3. Always replace the strainer when replacing the hot gas valve.

- 1) Turn off the power supply.
- 2) Remove the panels. Be sure to disconnect the dispense switch connector from the control box when removing the front panel.
- 3) Recover the refrigerant and store it in an approved container.
- 4) Remove the screw and the solenoid.
- 5) Disconnect the hot gas valve using brazing equipment.
- 6) Install the new valve.

CAUTION

Always protect the valve body by using a damp cloth to prevent the valve from overheating. Do not braze with the valve body exceeding 250°F (121°C).

- 7) Install the new drier.
- 8) Check for leaks using nitrogen gas (140 PSIG) and soap bubbles.
- 9) Evacuate the system, and charge it with refrigerant. See the nameplate for the required refrigerant charge.
- 10) Cut the leads of the solenoid allowing enough lead length to reconnect using closed end connectors.
- 11) Connect the new solenoid leads.
- 12) Attach the solenoid to the valve body, and secure it with a screw.
- 13) Replace the panels in their correct positions.
- 14) Turn on the power supply.

G. Removal and Replacement of Evaporator

IMPORTANT

1. Always install a new drier every time the sealed refrigeration system is opened. Do not replace the drier until after all other repairs or replacement have been made.
2. Because the pipes in the evaporator section are specially coated to resist corrosion, it is important to make the new evaporator inlet and outlet piping connections outside the evaporator section as described below.

- 1) Turn off the power supply.
- 2) Remove the outer panels and the evaporator insulation panels. Be sure to disconnect the dispense switch connector from the control box when removing the front panel.
- 3) Recover the refrigerant and store it in an approved container.
- 4) Remove the spray tubes and the insulations at the "U" shaped notch where the refrigeration tubings go through the molded chassis.
- 5) Remove the insulation tube, and disconnect the evaporator inlet piping at the tee before the expansion valve. Disconnect the evaporator outlet piping before the heat exchanger.

- 6) Remove the pop rivets securing the evaporator, then lift out the evaporator.
- 7) Install the new evaporator.
- 8) Install the new drier.
- 9) Check for leaks using nitrogen gas (140 PSIG) and soap bubbles.
- 10) Evacuate the system, and charge it with refrigerant. See the nameplate for the required refrigerant charge.
- 11) Replace the removed parts in the reverse order of which they were removed.
- 12) Replace the evaporator insulation panels and the outer panels in their correct positions.
- 13) Turn on the power supply.

H. Removal and Replacement of Condenser

- 1) Turn off the power supply.
- 2) Remove the panels, including the rear panel next to the condenser. Be sure to disconnect the dispense switch connector from the control box when removing the front panel.
- 3) Recover the refrigerant and store it in an approved container.
- 4) Disconnect the fan motor wiring harness from the back of the control box. Remove the four bolts securing the fan motor assembly to the floor of the machine, then remove the assembly.
- 5) Disconnect the condenser inlet and outlet piping.
- 6) Remove the screws securing the condenser assembly, then remove the assembly.
- 7) Remove the shroud from the old condenser and attach it to the new condenser.
- 8) Install the new condenser.
- 9) Install the new drier.
- 10) Check for leaks using nitrogen gas (140 PSIG) and soap bubbles.
- 11) Evacuate the system, and charge it with refrigerant. See the nameplate for the required refrigerant charge.
- 12) Replace the removed parts in the reverse order of which they were removed.
- 13) Replace the panels in their correct positions.
- 14) Turn on the power supply.

I. Removal and Replacement of Thermistor

IMPORTANT

1. Fragile, handle very carefully.
2. Always use a recommended sealant (High Thermal Conductive Type), Model KE4560RTV manufactured by SHINETSU SILICONE, Part Code 60Y000-11, or Part Code [4A0683-01](#) or equivalent.
3. Always use a recommended foam insulation (non-absorbent type) or equivalent.
4. Do not shorten or cut the thermistor leads when installing it.

- 1) Turn off the power supply.
- 2) Remove the panels. Be sure to disconnect the dispense switch connector from the control box when removing the front panel.
- 3) Remove the control box cover.
- 4) Disconnect the thermistor leads from the K3 connector on the control board.
- 5) Remove the plastic cable ties, foam insulation, thermistor holder and thermistor.
- 6) Scrape away the old sealant on the thermistor holder and the suction pipe.
- 7) Wipe off moisture or condensation on the suction pipe.
- 8) Smoothly apply recommended sealant (KE4560RTV, Part Code 60Y000-11 or [4A0683-01](#)) to the thermistor holder concave.
- 9) Attach the new thermistor to the suction pipe in the same position as the previous thermistor. Be very careful to prevent damage to the leads. Secure it using the thermistor holder and recommended foam insulation.

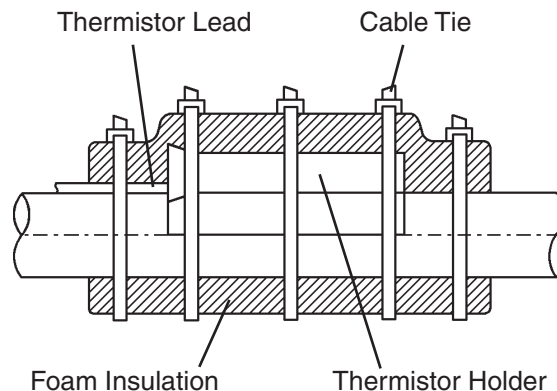

- 10) Secure the insulation using the plastic cable ties.
- 11) Connect the thermistor leads through the bushing of the control box to the K3 connector on the control board.
Note: Do not cut the leads of the thermistor while installing it.
- 12) Replace the control box cover and the panels in their correct positions.
- 13) Turn on the power supply.

J. Removal and Replacement of Fan Motor

Note: When replacing a fan motor with defective winding, it is recommended that a new capacitor be installed.

- 1) Turn off the power supply.
- 2) Remove the panels. Be sure to disconnect the dispense switch connector from the control box when removing the front panel.

- 3) Disconnect the fan motor wiring harness from the back of the control box. Remove the four bolts securing the fan motor assembly to the floor of the machine, then remove the assembly.
- 4) Remove the fan motor from the fan motor bracket.
- 5) Remove the fan blade from the old fan motor and attach it to the new fan motor.
- 6) Install the new fan motor, and replace the removed parts in the reverse order of which they were removed.
- 7) Replace the panels in their correct positions.
- 8) Turn on the power supply.

K. Removal and Replacement of Inlet Water Valve

- 1) Turn off the power supply.
- 2) Close the water supply line shut-off valve.
- 3) Remove the panels. Be sure to disconnect the dispense switch connector from the control box when removing the front panel.
- 4) Loosen the fitting nut. Be careful not to lose the washer.
- 5) Remove the screws securing the valve to the bracket.
- 6) Remove the screws attaching the bracket to the machine wall, then remove the bracket from the unit.
- 7) Remove the valve outlet tubing by releasing the clamp.
- 8) Disconnect the terminals from the water valve.
- 9) Install the new water valve, and replace the removed parts in the reverse order of which they were removed. Make sure the washer is in place in the fitting nut.
- 10) Open the water supply line shut-off valve.
- 11) Turn on the power supply.
- 12) Check for leaks.
- 13) Replace the panels in their correct positions.

L. Removal and Replacement of Pump Motor

- 1) Turn off the power supply.
- 2) Remove the panels. Be sure to disconnect the dispense switch connector from the control box when removing the front panel.
- 3) Remove the three screws securing the float switch assembly, then remove the assembly.
- 4) Remove the two screws securing the barrier directly over the pump, then remove the barrier.
- 5) Remove the wiring connectors from the pump motor leads.
- 6) Remove the four screws securing the pump motor, disconnect the hoses, then remove the pump motor.

- 7) Install the new pump, and replace the removed parts in the reverse order of which they were removed.
- 8) Turn on the power supply, and check for leaks.
- 9) Replace the panels in their correct positions.

M. Removal and Replacement of Spray Tubes

- 1) Turn off the power supply.
- 2) Remove the outer panels and the evaporator insulation panels. Be sure to disconnect the dispense switch connector from the control box when removing the front panel.
- 3) Remove the rubber hoses from the spray tubes (water supply pipe).
- 4) Release the clamps, and disconnect the rubber hoses.
- 5) Remove the spray tubes.
- 6) Install the new spray tubes, and replace the removed parts in the reverse order of which they were removed.
- 7) Replace the evaporator insulation panels and the outer panels in their correct positions.
- 8) Turn on the power supply.

N. Removal and Replacement of Gear Motor

- 1) Turn off the power supply.
- 2) Remove the panels. Be sure to disconnect the dispense switch connector from the control box when removing the front panel.
- 3) Disconnect the gear motor wiring harness from the back of the control box.
- 4) Loosen the adjustment bolt, then loosen the four bolts securing Gear Motor Bracket (B).
- 5) Slide Gear Motor Bracket (B) up to its highest position and retighten.
- 6) Remove the chain.
- 7) Loosen the socket set screw securing the sprocket, then use a gear puller to remove the sprocket.
- 8) Remove the bushing from the barrier and slide the gear motor wires free of the barrier. Release the wires from the wire tie on the barrier.
- 9) While supporting the gear motor and barrier, remove the four bolts securing them to Gear Motor Bracket (B). Carefully remove the motor and barrier.

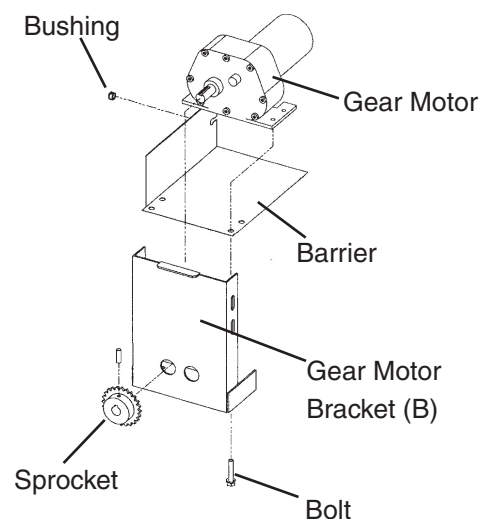
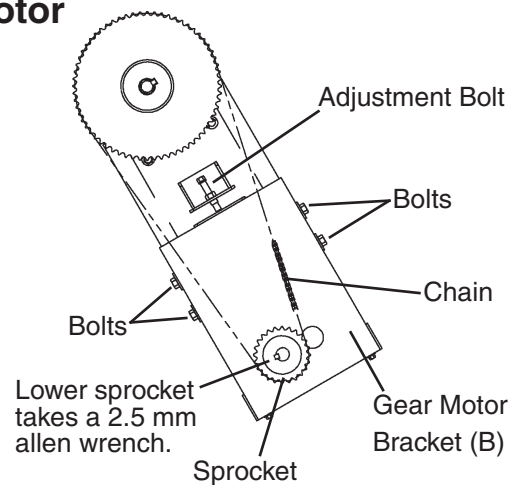

10) Install the new gear motor, assembling the removed parts in the reverse order of the above procedure.

Note:

- When weight (2.2 lb) is applied to the chain at the center, the displacement must be 0.31 to 0.51".
- Lubricant (Class SAE 20) must be applied to the chain using a cloth.

11) Replace the panels in their correct positions.

12) Turn on the power supply.

O. Removal and Replacement of Dispense Switch

1) Turn off the power supply.

2) Remove the front panel. Be sure to disconnect the dispense switch connector from the control box when removing the front panel.

3) Remove the dispense switch assembly.

4) Install a new dispense switch.

5) Replace the front panel in its correct position.

6) Turn on the power supply.

P. Removal and Replacement of Solenoid

1) Turn off the power supply.

2) Remove the panels. Be sure to disconnect the dispense switch connector from the control box when removing the front panel.

3) Disconnect the connectors from the solenoid leads.

4) Remove the solenoid, and install a new solenoid.

5) Connect the connectors to the solenoid leads.

6) Replace the panels in their correct positions.

7) Turn on the power supply.

VI. Cleaning and Maintenance Instructions

IMPORTANT

Ensure all components, fasteners and thumbscrews are securely in place after any maintenance or cleaning is done to the equipment.

A. Cleaning Instructions

To clean the machine, perform the cleaning and sanitizing procedures for the icemaker and bin in the order in which they appear below.

WARNING

1. Hoshizaki recommends cleaning this unit at least once a year. More frequent cleaning, however, may be required in some existing water conditions.
2. To prevent injury to individuals and damage to the icemaker, do not use ammonia type cleaners.
3. Always wear liquid-proof gloves to prevent the cleaning and sanitizing solutions from coming into contact with skin.

1. Cleaning Procedure – Icemaker

- 1) Dilute approximately 10.5 fl. oz. of recommended cleaner Hoshizaki "Scale Away" or "LIME-A-WAY," (Economics Laboratory, Inc.) with 2 gallons of warm water.
- 2) Remove all ice from the evaporator and the bin.
Note: To remove cubes on the evaporator, turn off the power supply and turn it on after 3 minutes. The defrost cycle starts and the cubes will be removed from the evaporator.
- 3) Turn off the power supply.
- 4) Remove the front panel and disconnect the connector from the control box.
- 5) Move the control switch on the control box to the SERVICE position. Then move the service switch to the DRAIN position.
- 6) Replace the front panel in its correct position.
- 7) Turn on the power supply for 2 minutes.
- 8) Turn off the power supply.
- 9) Remove the front panel.
- 10) Disconnect the bin control connector.
Remove the three thumbscrews securing the bin cover, and remove the bin cover with the bin control attached.
- 11) Pour the cleaning solution into the water tank.
- 12) Move the service switch to the WASH position.
- 13) Replace the front panel in its correct position.
- 14) Turn on the power supply, and start the washing process.

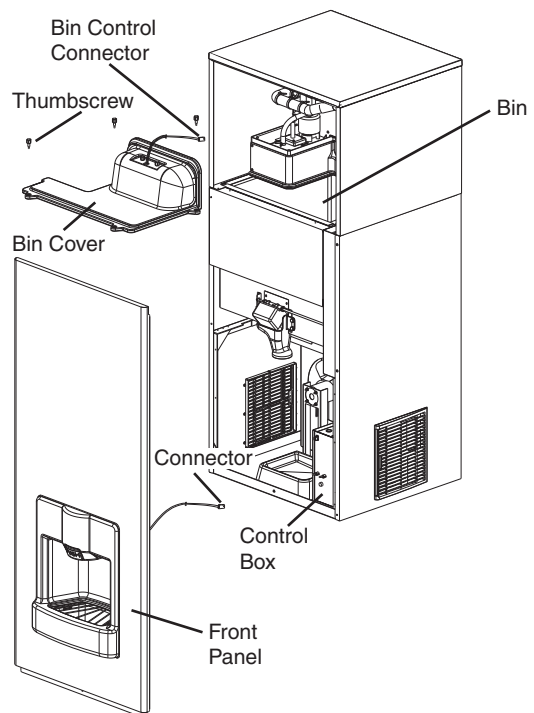

- 15) Turn off the power supply after 30 minutes.
- 16) Remove the front panel.
- 17) Move the service switch to the DRAIN position.
- 18) Replace the front panel in its correct position.
- 19) Turn on the power supply for 2 minutes.
- 20) Turn off the power supply.
- 21) Remove the front panel.
- 22) Move the control switch to the ICE position.
- 23) Replace the front panel in its correct position.
- 24) Turn on the power supply to fill the water tank with water.
- 25) Turn off the power supply after 3 minutes.
- 26) Remove the front panel.
- 27) Move the control switch to the SERVICE position. Then move the service switch to the WASH position.
- 28) Replace the front panel in its correct position.
- 29) Turn on the power supply to rinse off the cleaning solution.
- 30) Turn off the power supply after 5 minutes.
- 31) Remove the front panel.
- 32) Move the service switch to the DRAIN position.
- 33) Replace the front panel in its correct position.
- 34) Turn on the power supply for 2 minutes.
- 35) Turn off the power supply.
- 36) Remove the front panel.
- 37) Repeat the above steps 22 through 36 three more times to rinse thoroughly, then proceed to "2. Sanitizing Procedure – Icemaker".

2. Sanitizing Procedure – Icemaker

- 1) Dilute approximately 1.0 fl. oz. of a 5.25% sodium hypochlorite solution (chlorine bleach) with 2 gallons of warm water.
- 2) Pour the sanitizing solution into the water tank.
- 3) Move the service switch to the WASH position.
- 4) Replace the front panel in its correct position.
- 5) Turn on the power supply, and start the sanitizing process.
- 6) Turn off the power supply after 15 minutes.
- 7) Remove the front panel.
- 8) Move the service switch to the DRAIN position.
- 9) Replace the front panel in its correct position.

- 10) Turn on the power supply for 2 minutes.
- 11) Turn off the power supply.
- 12) Remove the front panel.
- 13) Repeat steps 22 through 36 in "Cleaning Procedure – Icemaker" two times to rinse thoroughly.
- 14) Move the control switch to the ICE position, then proceed to "3. Cleaning Procedure – Bin".

3. Cleaning Procedure – Bin

- 1) Dilute approximately 5 fl. oz. of recommended cleaner Hoshizaki "Scale Away" or "LIME-A-WAY," (Economics Laboratory, Inc.) with 1 gallon of warm water.
- 2) Make sure that the power supply is off.
- 3) Remove the grill and chute from the front panel.
- 4) Remove the shutter and spout extension as follows:
 - a. Remove the snap pin fitted to the shutter shaft. Shift the shaft to the left, pull out the right side and slide out.
 - b. Remove the four thumbscrews securing the spout extension and remove the spout extension.
- 5) Remove the two thumbscrews securing the bin control assembly to the bin cover. Note the orientation of the stainless steel bracket, then remove the bin control and bracket from the bin cover. Carefully remove the bin control paddle from the bin control body.
- 6) Scrub the inside of the bin, the agitator, the bin spout, the spout extension, the shutter, the front panel spout, the grill, the chute, the bin cover, and the bin control assembly using a nylon scouring pad, brushes and cleaning solution.
- 7) Rinse all parts thoroughly with clean water, then proceed to "4. Sanitizing Procedure – Bin".

4. Sanitizing Procedure – Bin

- 1) Dilute approximately .5 fl. oz. of a 5.25% sodium hypochlorite solution (chlorine bleach) with 1 gallon of warm water.
- 2) Wash all parts from step 6 of "Cleaning Procedure – Bin" with the sanitizing solution.
- 3) Rinse all parts thoroughly with clean water.
- 4) Reassemble all parts in the reverse order of the removal procedure.
- 5) Turn on the power supply.
- 6) Check for proper operation.

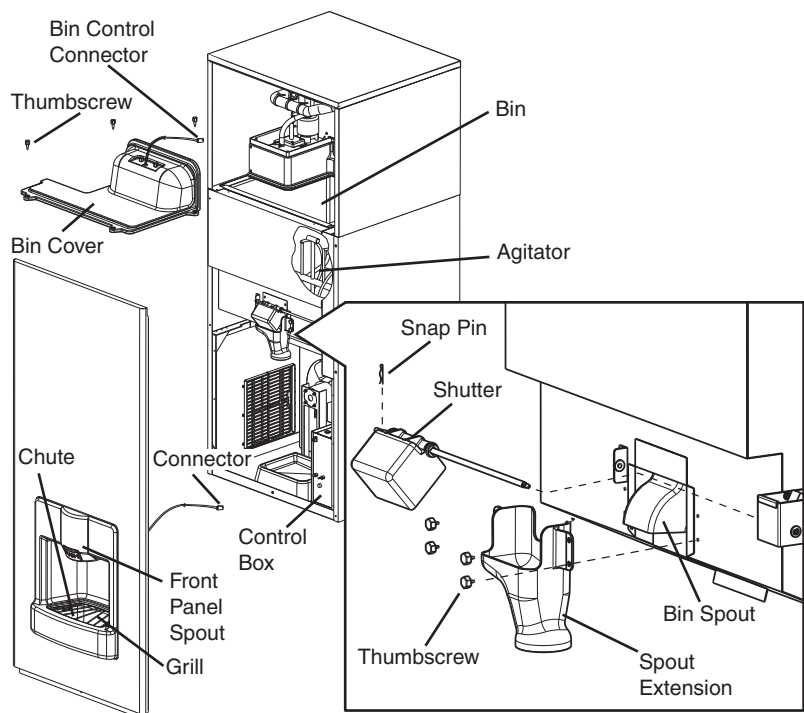

B. Maintenance Instructions

1. Exterior Panels

To keep the exterior clean, wipe occasionally with a clean and soft cloth. Use a damp cloth containing a neutral cleaner to wipe off oil or dirt buildup.

2. Air Filters

The plastic mesh air filters (located behind the louvers on either side of the unit) remove dirt and dust from the air, and keep the condenser from getting clogged. As the filters get clogged, the icemaker's performance will be reduced. Check the filters at least twice a month. When they are clogged, use warm water and a neutral cleaner to wash the filters.

3. Condenser

Check the condenser once a year and clean if required by using a brush or vacuum cleaner. More frequent cleaning may be required depending on the location of the icemaker.

C. Preparing the Icemaker for Long Storage

IMPORTANT

When shutting off the icemaker for an extended time, drain the water tank and remove the ice from the bin. The bin should be cleaned and dried. Drain the icemaker to prevent damage to the water supply line at sub-freezing temperatures, using a foot or hand pump. Shut off the icemaker until proper air temperature is resumed.

- 1) Turn off the power supply.
- 2) Remove the front panel and disconnect the connector from the control box.
- 3) Move the control switch on the control box to the SERVICE position. Then move the service switch to the DRAIN position.
- 4) Replace the front panel in its correct position.
- 5) Turn on the power supply for 2 minutes to allow the machine to drain.
- 6) Turn off the power supply.
- 7) Remove the front panel.
- 8) Move the control switch to the OFF position.
- 9) Close the water supply line shut-off valve.
- 10) Remove ice from the bin, then clean and dry the bin.
- 11) Reconnect the connector from the front panel to the control box and replace the front panel in its correct position.

IMPORTANT

When the icemaker is not used for two or three days, move only the control switch to the OFF position.