

Hoshizaki America, Inc.

Modular Flaker

Model

F-1001MAH (-C) (-22C)

F-1001MWH (-C)

F-1001MRH (-C)

F-1001MLH (-C)



“A Superior Degree
of Reliability”

www.hoshizaki.com

INSTRUCTION MANUAL



Issued: 2-21-2001
Revised: 12-30-2004

IMPORTANT

Only qualified service technicians should attempt to install, service or maintain this icemaker. No installation, service or maintenance should be undertaken until the technician has thoroughly read this Instruction Manual. Likewise, the owner/manager should not proceed to operate the icemaker until the installer has instructed them on its proper operation.

HOSHIZAKI provides this manual primarily to assist qualified service technicians in the installation, maintenance and service of the icemaker.

Should the reader have any questions or concerns which have not been satisfactorily addressed, please call or write to the HOSHIZAKI Technical Support Department for assistance.

HOSHIZAKI AMERICA, INC.
618 Highway 74 South
Peachtree City, GA 30269

Attn: HOSHIZAKI Technical Support Department

Phone: 1-800-233-1940 Technical Service
(770) 487-2331
Fax: (770) 487-3360

Web Site: www.hoshizakiamerica.com

Note: To expedite assistance, all correspondence/communication **MUST** include the following information:

- Model Number
- Serial Number
- Complete and detailed explanation of the problem

- Please review this manual. It should be read carefully before the icemaker is installed and operated. Only qualified service technicians should install, service and maintain the icemaker. This manual should be made available to the technician prior to installation, maintenance or service.
- Keep this manual with the icemaker for later reference.



CONTENTS

I. Specifications	4
1. Nameplate Rating	4
[a] F-1001MAH, F-1001MAH-C (air-cooled)	4
[b] F-1001MWH, F-1001MWH-C (water-cooled)	5
[c] F-1001MRH, F-1001MRH-C (remote air-cooled)	6
[d] F-1001MLH, F-1001MLH-C (rack system)	7
[e] F-1001MAH-22C (air-cooled)	8
2. Dimensions/Connections	9
[a] F-1001MAH, F-1001MAH-C, F-1001MAH-22C	9
[b] F-1001MWH, F-1001MWH-C	10
[c] F-1001MRH, F-1001MRH-C	11
[d] F-1001MLH, F-1001MLH-C	12
[e] With Storage Bin	13
[f] Condenser Unit – Model URC-6F	14
II. Installation and Operating Instructions	15
1. Checks Before Installation	15
2. How to Remove Panels	15
3. Location	16
4. Setup	16
5. Electrical Connection	17
6. Installation of Remote Condenser Unit	18
[a] Checks Before Installation	18
[b] Location	18
[c] Setup	19
[d] Electrical Connection	20
[e] Stacking Condenser Unit	21
7. Water Supply and Drain Connections	21
8. Final Check List	23
9. Startup	24
10. Preparing the Icemaker for Long Storage	25
III. Cleaning and Maintenance	26
1. Cleaning and Sanitizing Instructions	26
[a] Cleaning Solution	26
[b] Cleaning Procedure	27
[c] Sanitizing Solution	28
[d] Sanitizing Procedure - Initial	28
[e] Sanitizing Procedure - Final	29
2. Maintenance Instructions	31

I. Specifications

1. Nameplate Rating

[a] F-1001MAH, F-1001MAH-C (air-cooled)

HOSHIZAKI ICE MAKER			
MODEL NUMBER	F-1001MAH		
SERIAL NUMBER			
AC SUPPLY VOLTAGE	208-230/60/1 (3 wire with Neutral for 115V)		
COMPRESSOR	240V	4.2RLA	34LRA
GEAR MOTOR	120V	3.0FLA	1/4HP
FAN MOTOR	120V	0.85FLA	1/15HP
OTHER	120V	0.03A	
MAXIMUM FUSE SIZE	15 AMPS		
MAX. HACR BREAKER (USA ONLY)	15 AMPS		
MAX. CIRC. BREAKER (CANADA ONLY)	15 AMPS		
MINIMUM CIRCUIT AMPACITY	15 AMPS		
DESIGN PRESSURE	HI-427PSI	LO-230PSI	
REFRIGERANT	404A	1lb. 12oz.	
MOTOR-COMPRESSOR THERMALLY PROTECTED			
NOT INTENDED FOR OUTDOOR USE			
HOSHIZAKI AMERICA, INC. Peachtree City, GA			
 LISTED ICE MAKER WITHOUT STORAGE MEANS 946Z			 COMPONENT 

See the nameplate for electrical and refrigeration specifications. This nameplate is located on the upper right hand side of rear panel.

We reserve the right to make changes in specifications and design without prior notice.

NOTE: Only the "MODEL NUMBER" is replaced for F-1001MAH-C.

[b] F-1001MWH, F-1001MWH-C (water-cooled)



HOSHIZAKI ICE MAKER			
MODEL NUMBER	F-1001MWH		
SERIAL NUMBER			
AC SUPPLY VOLTAGE	208-230/60/1 (3 wire with Neutral for 115V)		
COMPRESSOR	240V	4.2RLA	34LRA
GEAR MOTOR	120V	3.0FLA	1/4HP
FAN MOTOR	—	—	—
OTHER	120V	0.03A	
MAXIMUM FUSE SIZE	15 AMPS		
MAX. HACR BREAKER (USA ONLY)	15 AMPS		
MAX. CIRC. BREAKER (CANADA ONLY)	15 AMPS		
MINIMUM CIRCUIT AMPACITY	15 AMPS		
DESIGN PRESSURE	HI-427PSI LO-230PSI		
REFRIGERANT	404A	15oz.	
MOTOR-COMPRESSOR THERMALLY PROTECTED			
NOT INTENDED FOR OUTDOOR USE			
HOSHIZAKI AMERICA, INC.			
Peachtree City, GA			
 LISTED ICE MAKER WITHOUT STORAGE MEANS 946Z			
			
 COMPONENT			

See the nameplate for electrical and refrigeration specifications. This nameplate is located on the upper right hand side of rear panel.

We reserve the right to make changes in specifications and design without prior notice.

NOTE: Only the “MODEL NUMBER” is replaced for F-1001MWH-C.

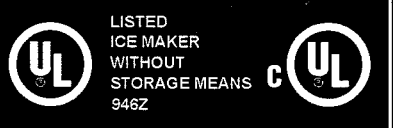
[c] F-1001MRH, F-1001MRH-C (remote air-cooled)





HOSHIZAKI ICE MAKER			
MODEL NUMBER	F-1001MRH		
SERIAL NUMBER			
AC SUPPLY VOLTAGE			
208-230/60/1 (3 wire with Neutral for 115V)			
COMPRESSOR	240V	4.2RLA	34LRA
GEAR MOTOR	120V	3.0FLA	1/4HP
FAN MOTOR	REMOTE	120V	3A MAX
OTHER	120V	0.53A	
MAXIMUM FUSE SIZE	15 AMPS		
MAX. HACR BREAKER (USA ONLY)	15 AMPS		
MAX. CIRC. BREAKER (CANADA ONLY)	15 AMPS		
MINIMUM CIRCUIT AMPACITY	15 AMPS		
DESIGN PRESSURE	HI-427PSI	LO-230PSI	
REFRIGERANT	404A		
MOTOR-COMPRESSOR THERMALLY PROTECTED			
NOT INTENDED FOR OUTDOOR USE			
HOSHIZAKI AMERICA, INC.			
Peachtree City, GA			
  			

See the nameplate for electrical and refrigeration specifications. This nameplate is located on the upper right hand side of rear panel.

We reserve the right to make changes in specifications and design without prior notice.

NOTE: Only the "MODEL NUMBER" is replaced for F-1001MRH-C.

[d] F-1001MLH, F-1001MLH-C (rack system)



HOSHIZAKI ICE MAKER			
MODEL NUMBER	F-1001MLH		
SERIAL NUMBER			
AC SUPPLY VOLTAGE	115-120/60/1 (3 wire with Neutral for 115V)		
COMPRESSOR	_____	_____	_____
GEAR MOTOR	120V	3.0FLA	1/4HP
FAN MOTOR	_____	_____	_____
OTHER	120V	0.53A	
MAXIMUM FUSE SIZE	15 AMPS		
MAX. HACR BREAKER (USA ONLY)	15 AMPS		
MAX. CIRC. BREAKER (CANADA ONLY)	15 AMPS		
MINIMUM CIRCUIT AMPACITY	15 AMPS		
DESIGN PRESSURE	HI-427PSI	LO-230PSI	
REFRIGERANT	404A		
MOTOR-COMPRESSOR THERMALLY PROTECTED			
NOT INTENDED FOR OUTDOOR USE			
HOSHIZAKI AMERICA, INC.			
Peachtree City, GA			
	LISTED ICE MAKER WITHOUT STORAGE MEANS 946Z		
			COMPONENT 

See the nameplate for electrical and refrigeration specifications. This nameplate is located on the upper right hand side of rear panel.

We reserve the right to make changes in specifications and design without prior notice.

NOTE: Only the "MODEL NUMBER" is replaced for F-1001MLH-C.

[e] F-1001MAH-22C (air-cooled)

HOSHIZAKI ICE MAKER			
MODEL NUMBER	F-1001MAH-22C		
SERIAL NUMBER			
AC SUPPLY VOLTAGE	208-230/60/1 (3 wire with Neutral for 115V)		
COMPRESSOR	240V	4.5RLA	34LRA
GEAR MOTOR	120V	3.0FLA	1/4HP
FAN MOTOR	115V	0.85FLA	1/15HP
OTHER	120V	0.03A	
MAXIMUM FUSE SIZE	15 AMPS		
MAX. HACR BREAKER (USA ONLY)	15 AMPS		
MAX. CIRC. BREAKER (CANADA ONLY)	15 AMPS		
MINIMUM CIRCUIT AMPACITY	15 AMPS		
DESIGN PRESSURE	HI-400PSI	LO-230PSI	
REFRIGERANT	404A	1lb. 7oz.	
MOTOR-COMPRESSOR THERMALLY PROTECTED			
NOT INTENDED FOR OUTDOOR USE			
HOSHIZAKI AMERICA, INC.			
Peachtree City, GA			
 LISTED ICE MAKER WITHOUT STORAGE MEANS 946Z			
		 COMPONENT	

See the nameplate for electrical and refrigeration specifications. This nameplate is located on the upper right hand side of rear panel.

We reserve the right to make changes in specifications and design without prior notice.

NOTE: Only the "MODEL NUMBER" is replaced for F-1001MRH-C.

2. Dimensions/Connections

[a] F-1001MAH, F-1001MAH-C, F-1001MAH-22C

Unit = inches [mm.]

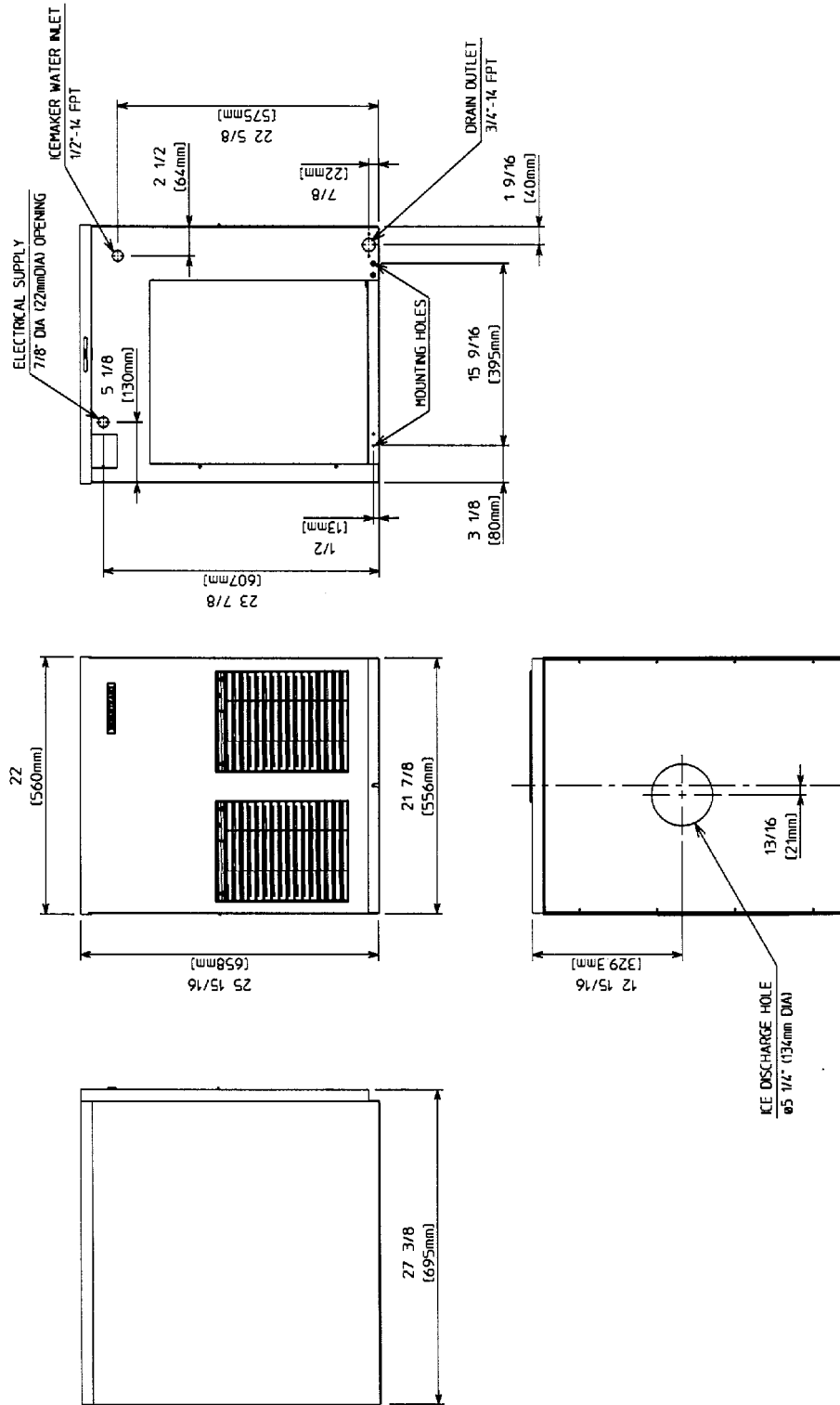

[b] F-1001MWH, F-1001MWH-C

Unit = inches [mm.]

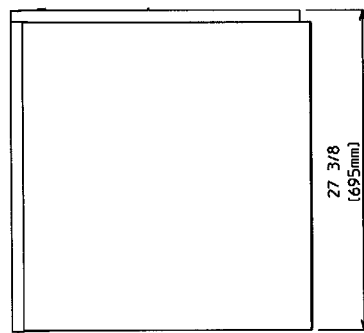
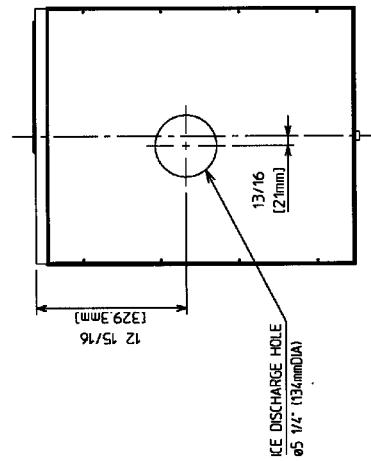
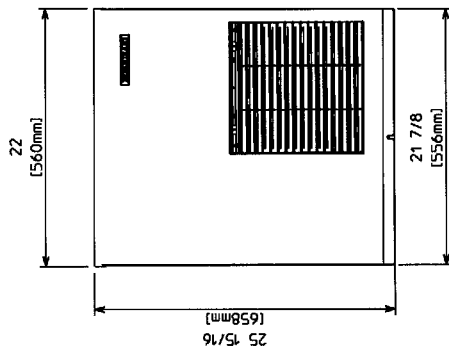
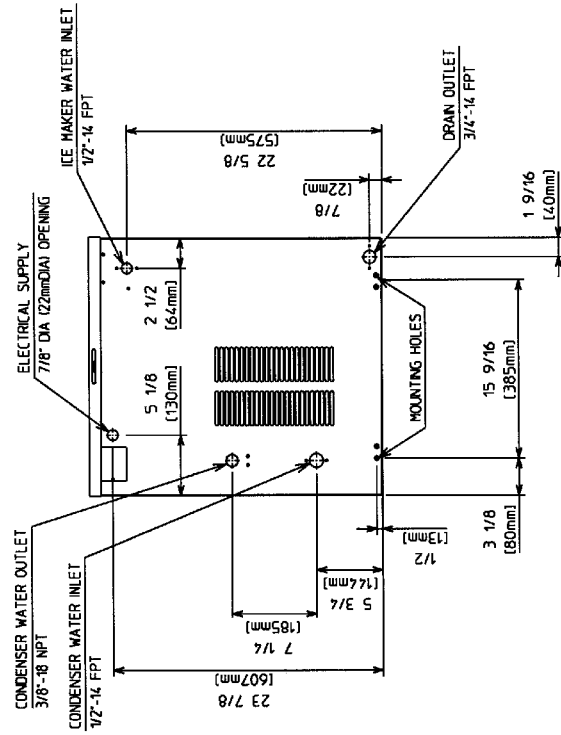

[c] F-1001MRH, F-1001MRH-C

Unit = inches [mm.]

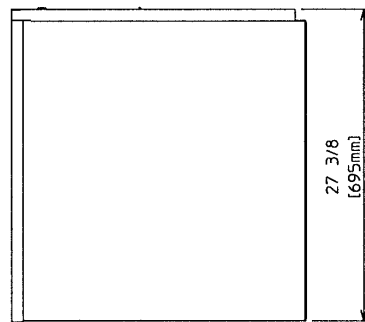
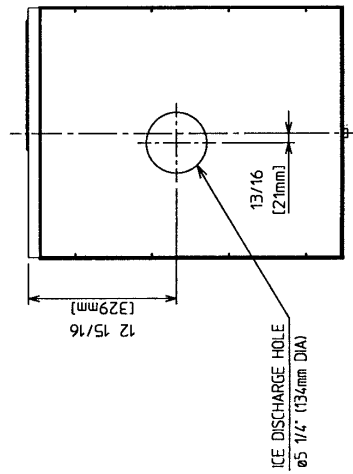
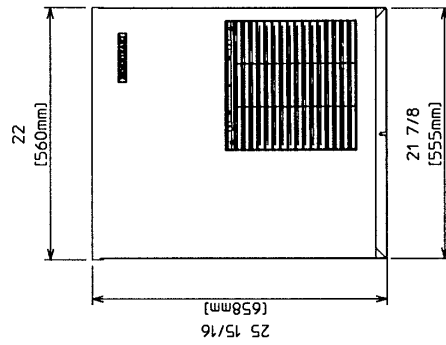
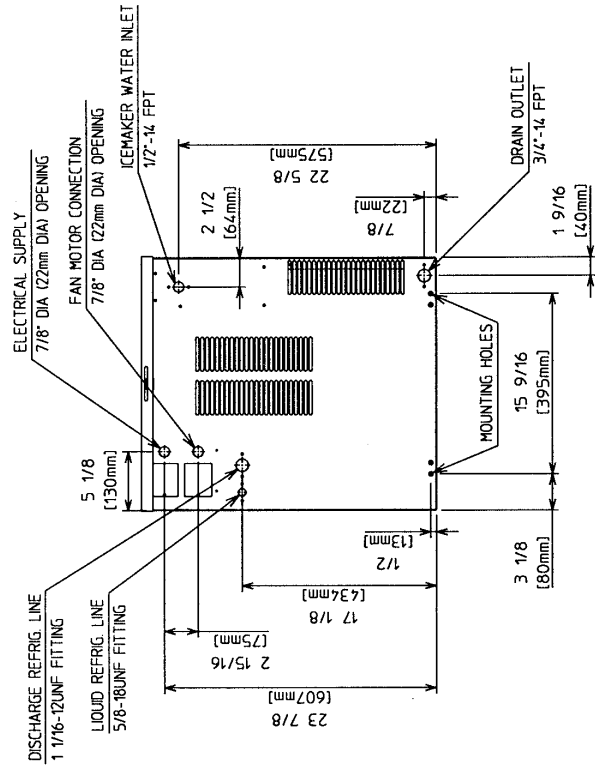

[e] With Storage Bin

Unit = inches [mm.]

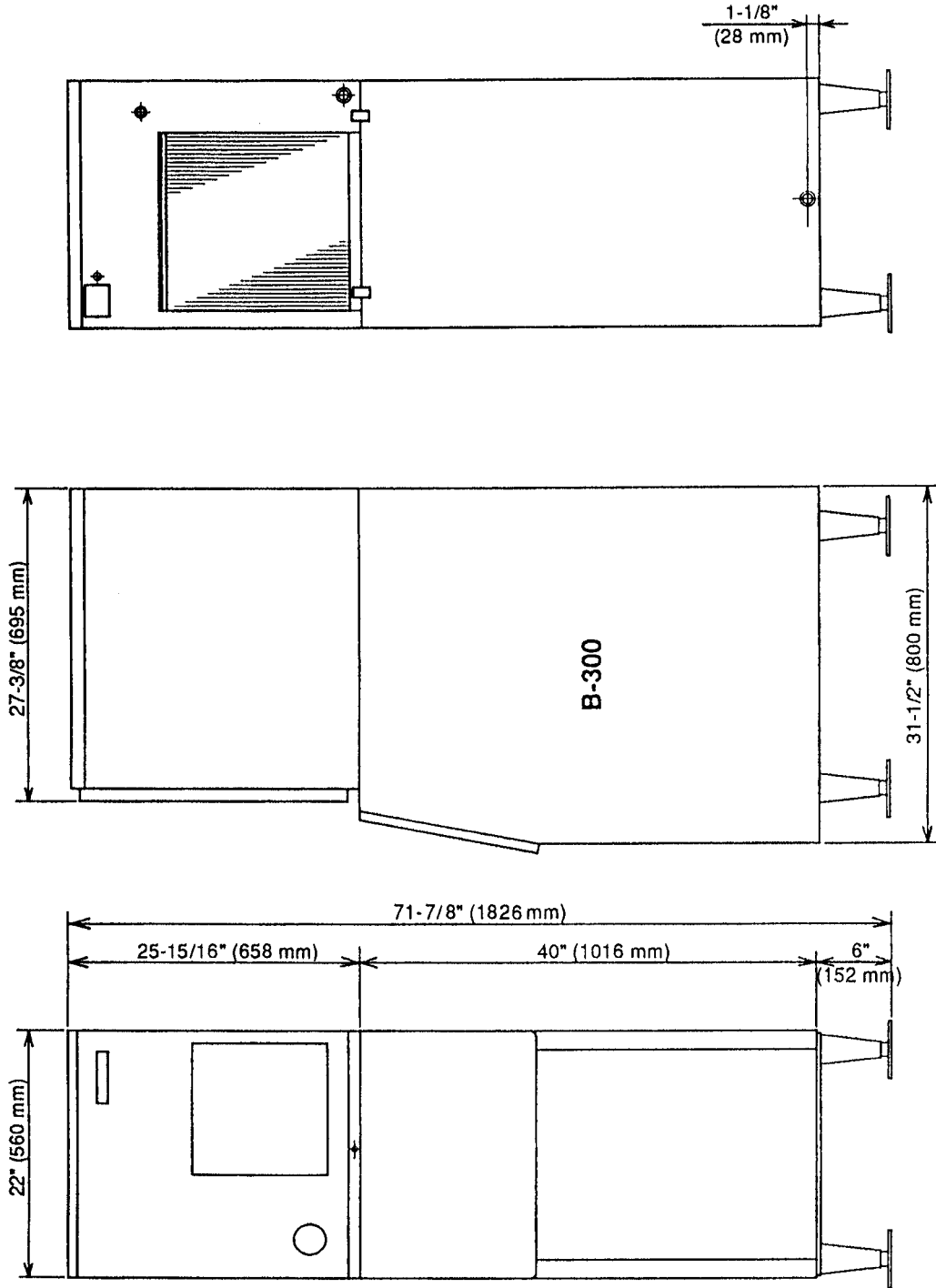

[f] Condenser Unit – Model URC-6F

Unit = mm. [inches]

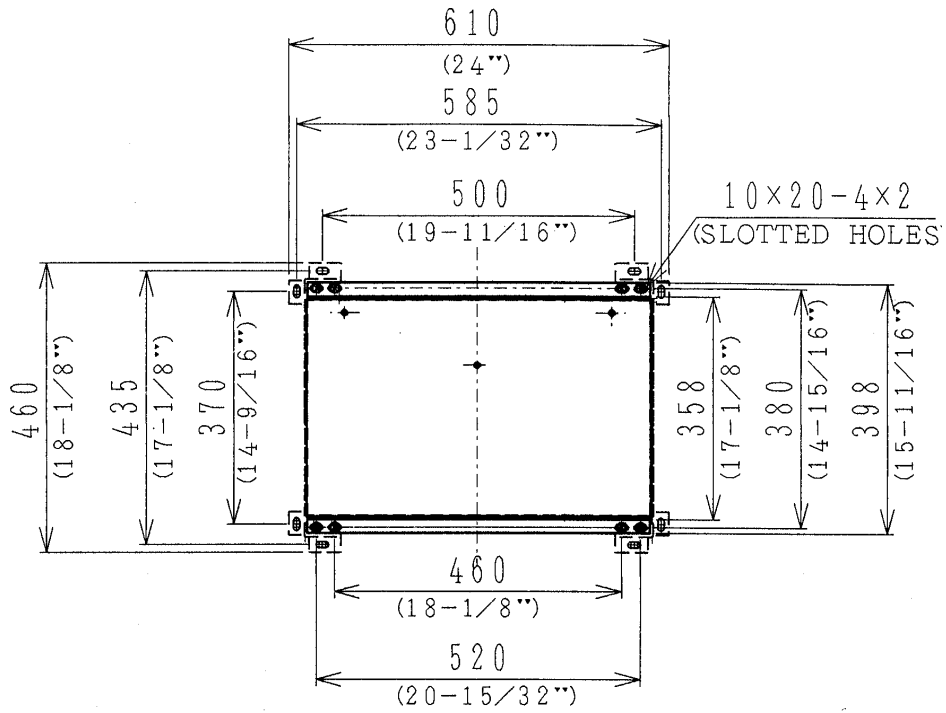

TOP VIEW

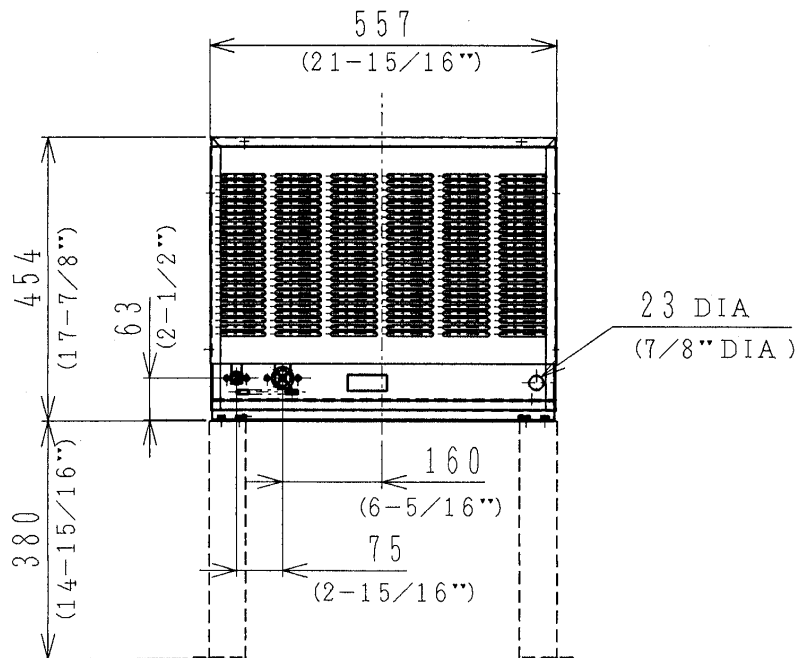

II. Installation and Operating Instructions

1. Checks Before Installation

WARNING

Remove shipping carton, tape(s) and packing. If packing material is left in the icemaker, it will not work properly.

IMPORTANT

Ensure all components, fasteners and thumbscrews are securely in place.

- 1) Remove the front, top and side panels to prevent damage when installing the icemaker. (See "2. How to Remove Panels.")
- 2) Remove the package containing the accessories from inside the icemaker.
- 3) Remove the protective plastic film from the panels. If the icemaker is exposed to the sun or to heat, remove the film after the icemaker cools.
- 4) Check that the refrigerant lines do not rub or touch lines or other surfaces, and that the fan blade turns freely.
- 5) Check that the compressor is snug on all mounting pads.
- 6) See the nameplate on the rear panel, and check that your voltage supplied corresponds with the voltage specified on the nameplate.
- 7) This icemaker needs a storage bin. The recommended storage bin is Hoshizaki Ice Storage Bin, Model B-300 series.
- 8) On remote air-cooled models, a remote condenser unit is needed. The recommended remote condenser unit is Hoshizaki Condenser Unit, Model URC-6F.

2. How to Remove Panels

See Fig. 1

- a) Front Panel..... Remove the screw.
Lift up and pull toward you.
- b) Top Panel..... Lift up front, push away,
and then lift off.
- c) Side Panel Remove the screw.
Pull slightly toward you, and
lift off.

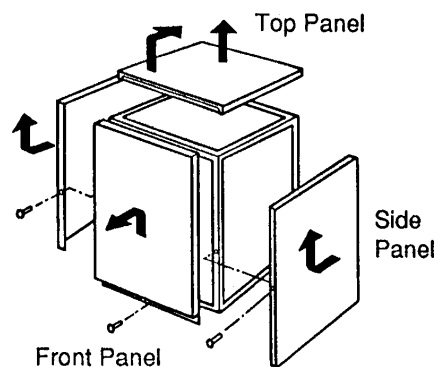

Fig. 1

3. Location

WARNING

This icemaker is not intended for outdoor use. Normal operating ambient temperature should be within +45°F to +100°F; Normal operating water temperature should be within +45°F to +90°F. Operation of the icemaker, for extended periods, outside of these normal temperature ranges may affect production capacity.

For best operating results:

- Icemaker should not be located next to ovens, grills or other high heat producing equipment.
- Location should provide a firm and level foundation for the equipment.
- Allow 6" clearance at rear and sides for proper air circulation and ease of maintenance and /or service should they be required. Allow 24" clearance at top to allow for removal of the auger.

4. Setup

- 1) Unpack the storage bin, and attach the four adjustable legs provided (bin accessory) to the bottom of the storage bin.
- 2) Position the storage bin in the selected permanent position.
- 3) Place the icemaker on the top of the storage bin.
- 4) Secure the icemaker to the storage bin, by using the two universal braces and two bolts provided. See Fig. 2.
- 5) Seal the seam between the icemaker and the storage bin.
- 6) Level the icemaker/storage bin in both the left-to-right and front-to-rear directions. Adjust the ice bin legs to make the icemaker level.
- 7) Replace the top panel and the front panel in their correct positions, and secure the front panel with a screw.

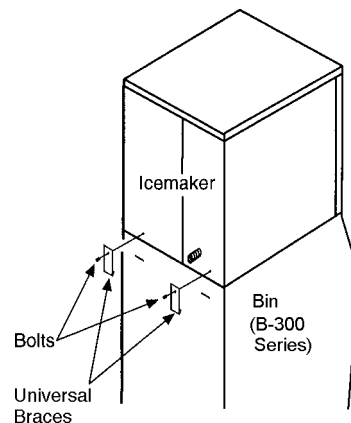

Fig. 2

5. Electrical Connection

WARNING

1. Electrical connection must be made in accordance with the instructions on a "WARNING" tag provided with the pig tail leads in the junction box.
2. This icemaker requires a ground that meets the national and local electrical code requirements. To prevent possible electrical shock to individuals or extensive damage to the equipment, install a proper ground wire to the icemaker.

- The white lead must be connected to the neutral conductor of the power source. Miswiring results in severe damage to the icemaker. See Fig. 3.
- This icemaker must have a separate power supply or receptacle of proper capacity. See the nameplate.
- The opening for the power supply connection is 7/8" DIA to fit a 1/2" trade size conduit.
- Usually an electrical permit and services of a licensed electrician are required

WARNING

ELECTRICAL CONNECTION

The white lead must be connected to the neutral conductor of the power source. Miswiring results in severe damage to the icemaker. (See Fig. below.)

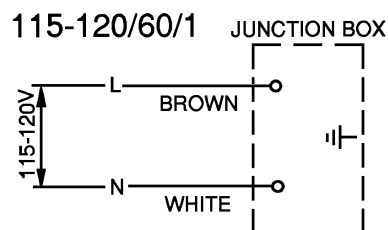

Fig. 3

6. Installation of Remote Condenser Unit

[a] Checks Before Installation

- 1) Unpack and remove shipping carton, tape(s) and packing.
- 2) Check that the refrigerant lines do not rub or touch lines or other surfaces, and that the fan blade turns freely.
- 3) Make sure that the icemaker, line sets and remote condenser unit all use R-404A refrigerant.

[b] Location

The condenser unit must be positioned in a permanent site under the following guidelines.

- A firm and flat site.
- A dry and well ventilated area with 24" clearance on both front and rear for ease of maintenance and service should they be required.
- Normal condenser ambient temperature: -20°F to +122°F. Temperatures not within this operating range may affect the production capacity of the icemaker.
- The maximum line length for the standard refrigerant charge is 66 feet. Should an installation require a longer line length, please call 1-800-233-1940 for recommendations concerning the correct additional refrigerant charge to be added.

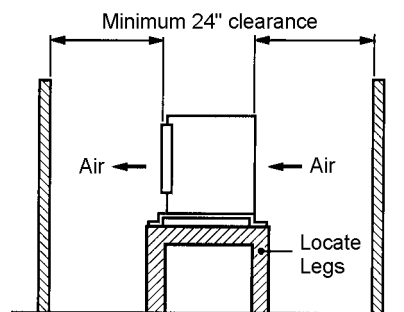

Fig. 4

Note: If the recommended guidelines of the installation are exceeded, the icemaker performance may be reduced.

[c] Setup

- 1) Secure the legs to the condenser unit with eight M8 x 16 mm hexagon bolts and M8 nuts as shown in the illustration. See Fig. 5.

Note: Locate the legs symmetrically.

- 2) The legs have eight mounting holes. Secure the legs with eight bolts (not included).

- 3) Install enough length of two copper tubings provided with Aeroquip couplings between the icemaker and the condenser unit. The two copper tubings should be insulated separately. See Fig. 6.

- Precharged tubing kits, available as optional equipment from Hoshizaki America, are recommended.

- 4) Line sets fabricated in the field should be evacuated through the charging ports on the Aeroquip couplings and charged with R-404A refrigerant vapor to a pressure of 15-30 PSIG.

Note: Factory fabricated tubing kits are precharged and do not need to be evacuated.

- 5) Remove the plastic caps protecting the couplings. Attach the two refrigerant lines to the male couplings on the icemaker and the remote condenser unit. Each refrigerant line must be connected as follows:

Icemaker discharge refrigerant line - 3/8" OD tubing to "DIS" of condenser unit
Icemaker liquid refrigerant line - 1/4" OD tubing to "LIQ" of condenser unit

Note: Make the connections at the remote condenser first and then at the icemaker.

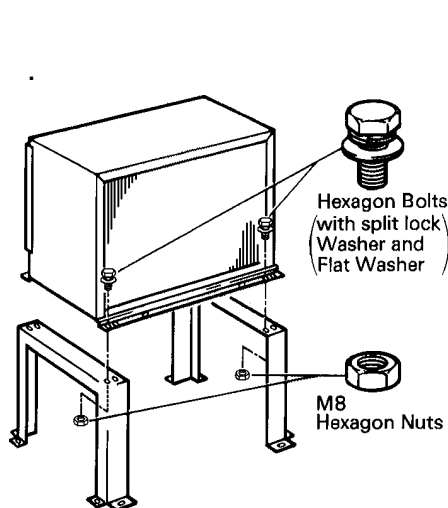

Fig. 5

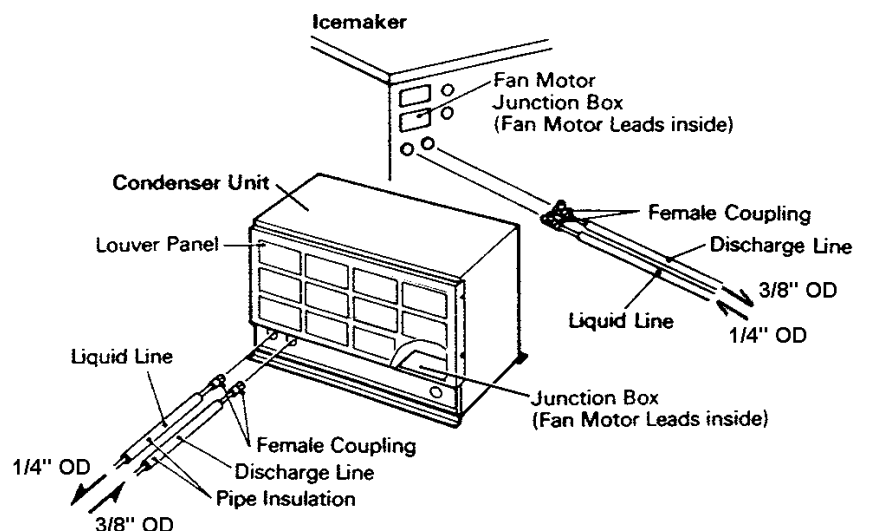

Fig. 6

[d] Electrical Connection

WARNING

This remote condenser unit requires a ground that meets the national and local electrical code requirements. To prevent possible electrical shock to individuals or extensive damage to equipment, install a proper ground wire to this condenser unit.

- This condenser unit must be connected to the fan motor junction box on the icemaker.
 - The opening for the power supply connection is 7/8" DIA to fit a 1/2" trade size conduit.
 - Usually an electrical permit and services of a licensed electrician are required.
- 1) Remove the louver panel.
 - 2) Remove the junction box cover.
 - 3) Connect the fan motor leads in the junction box of the remote condenser unit to the fan motor leads in the junction box of the Hoshizaki remote air-cooled icemaker.
 - 4) Install a ground wire from the icemaker to the remote condenser unit.
 - 5) Replace the junction box cover and the louver panel in their correct positions.

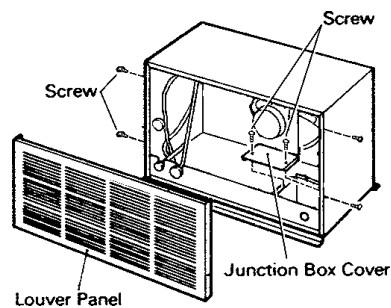

Fig. 7

[e] Stacking Condenser Unit

- 1) Secure the lower condenser unit to the legs with eight bolts (not included).
- 2) Attach the upper condenser unit on the top of the lower.
- 3) Secure the upper condenser unit with the four screws provided.
- 4) Install refrigerant lines, and make electrical connection for each fan motor as shown in Items [c] and [d].

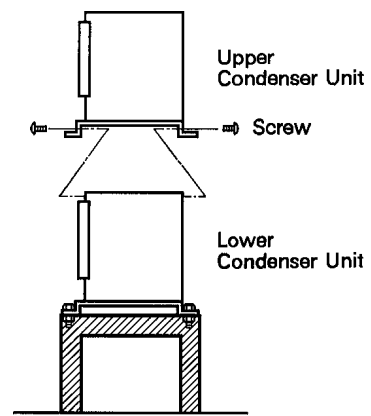

Fig. 8

7. Water Supply and Drain Connections

See Fig. 9

- External filters, strainers or softeners may be required depending on the water quality.
- Water supply inlet is 1/2" female pipe thread (FPT).

Note: On water-cooled model, two water supply inlets are provided. One is for ice making water, and the other is for cooling water.

- A water supply line shut-off valve and drain valve should be installed. A minimum of 3/8" OD copper tubing is recommended for the water supply lines.
- Water supply pressure should be a minimum of 10 PSIG and a maximum of 113 PSIG. If the pressure exceeds 113 PSIG, the use of a pressure reducing valve is required.
- Drain outlet for icemaking is 3/4" FPT. The icemaker drain and the condenser drain piping connections must be made separately from the bin drain.

Note: On water-cooled model, a 3/8" FPT is provided for the cooling water outlet.

- The drains must have 1/4" fall per foot on horizontal runs to get a good flow.
- The drains should not be piped directly to the sewer system. An air gap of a minimum of 2 vertical inches should be between the end of the drain pipe from the icemaker or the ice bin and the floor drain.
- A plumbing permit and services of a licensed plumber may be required in some areas.
- In some areas, a back flow preventer may be required in the cooling water circuit.

F-1001MAH, F-1001MAH-C
 F-1001MRH, F-1001MRH-C
 F-1001MLH, F-1001MLH-C
 F-1001MAH-22C

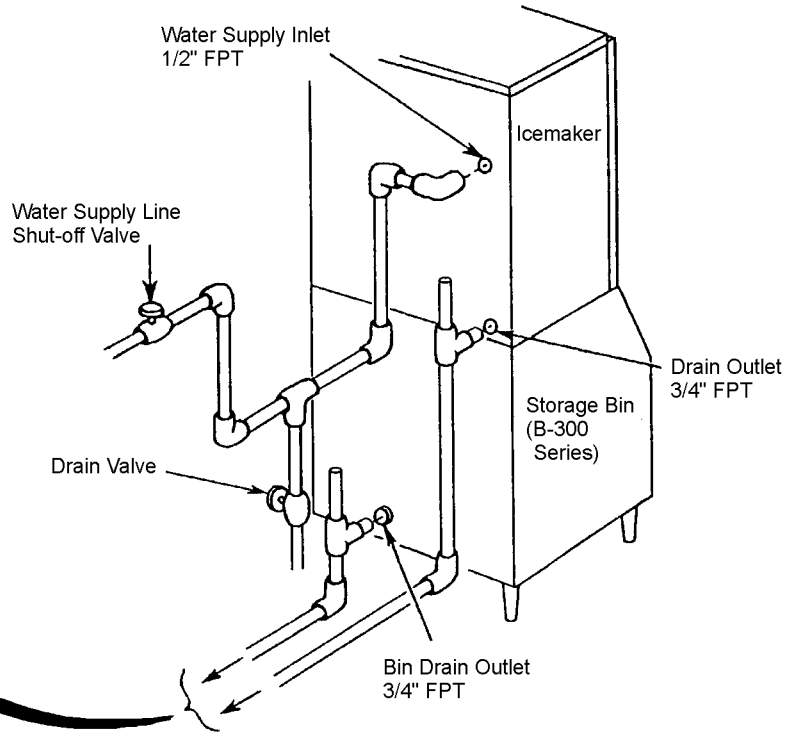
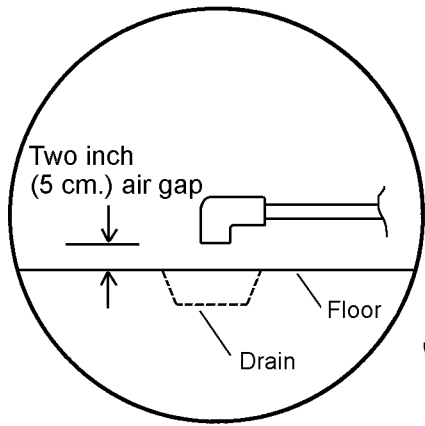

- Separate piping to approved drain. Leave a two-inch (5 cm.) vertical air gap between the end of each pipe and the drain.

- 1/4" fall per foot on horizontal run.

F-1001MWH, F-1001MWH-C

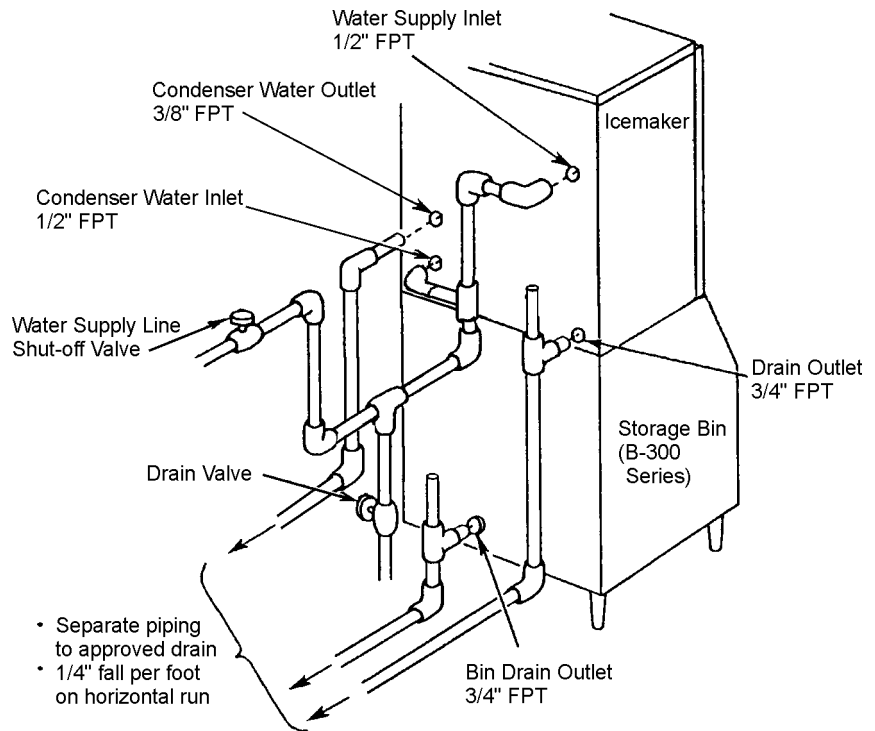

Fig. 9

- Separate piping to approved drain
- 1/4" fall per foot on horizontal run

8. Final Check List

- 1) Is the icemaker level?
- 2) Is the icemaker in a site where the ambient temperature is within +45°F to +100°F and the water temperature within +45°F to +90°F all year around?
- 3) Is there at least 6" clearance at rear and sides and 24" at top for maintenance or service?
- 4) Have all shipping carton, tape(s) and packing been removed from the icemaker?
- 5) Are all components, fasteners and thumbscrews securely in place?
- 6) Have all electrical and piping connections been made?
- 7) Has the power supply voltage been checked or tested against the nameplate rating and the correct voltage selected? And has a proper ground been installed in the icemaker?
- 8) Are the water supply line shut-off valve and drain valve installed? Has the water supply pressure been checked to ensure a minimum of 10 PSIG and a maximum of 113 PSIG?

Note: The icemaker may stop running when the water supply is OFF, or if the pressure is below 10 PSIG. When the proper water pressure is reached, the icemaker automatically starts running again.
- 9) Have the compressor hold-down bolts and refrigerant lines been checked against vibration and possible failure?
- 10) Has the bin control switch been checked for correct operation? Move the actuator located on the top of the chute. The compressor should stop in 6 seconds, and the gear motor in 6 seconds.
- 11) Has the end user been given the instruction manual, and instructed on how to operate the icemaker and the importance of the recommended periodic maintenance?
- 12) Has the end user been given the name and telephone number of an authorized service agent?
- 13) Has the warranty tag been filled out and forwarded to the factory for warranty registration?

9. Startup

WARNING

1. All parts are factory-adjusted. Improper adjustments may result in failure.
2. If the unit is turned off, wait for at least 3 minutes before restarting the icemaker to prevent damage to the compressor.

- 1) Clean the storage bin. (See "III. 2. Maintenance.")
- 2) Open the water supply line shut-off valve.
- 3) Move the flush switch on the control box to the "ICE" position.
- 4) Turn on the power switch on the control box.
- 5) Replace the side, top and front panels in their correct positions.
- 6) Turn on the power supply.

10. Preparing the Icemaker for Long Storage

See Fig. 10

WARNING

When shutting off the icemaker for an extended time, drain out all water from the water line and remove the ice from the storage bin. The storage bin should be cleaned and dried. Drain the icemaker to prevent damage to the water supply line at sub-freezing temperatures, using air or carbon dioxide. Shut off the icemaker until the proper ambient temperature is resumed.

- Air-cooled, Remote Air-cooled and Rack Models

- 1) Run the icemaker with the water supply line shut-off valve closed.
- 2) Open the drain valve and blow out the water inlet line by using air pressure.
- 3) Turn off the power supply.
- 4) Remove the front panel.
- 5) Move the flush switch on the control box to the "FLUSH" position.
- 6) Turn on the power supply, and then drain out all water from the water line.
- 7) Turn off the power supply.
- 8) Turn off the power switch on the control box.
- 9) Replace the front panel in its correct position.
- 10) Close the drain valve.
- 11) Remove all ice from the storage bin, and clean the bin.

- Water-cooled Model

- 1) Turn off the power supply and wait for 3 minutes.
- 2) Turn on the power supply and wait for 20 seconds.
- 3) Close the water supply line shut-off valve.
- 4) Open the drain valve and quickly blow the water supply line from the drain valve to drain water in the condenser.
- 5) Follow the above steps 3) through 11) in "• Air-cooled, Remote Air-cooled and Rack Models."

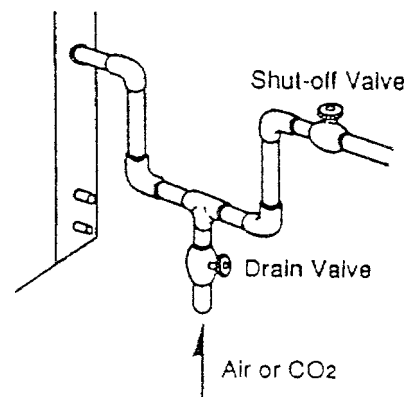

Fig. 10

III. Cleaning and Maintenance

IMPORTANT

Ensure all components, fasteners and thumbscrews are securely in place after any maintenance or cleaning is done to the equipment.

1. Cleaning and Sanitizing Instructions

WARNING

1. HOSHIZAKI recommends cleaning this unit at least once a year. More frequent cleaning, however, may be required in some existing water conditions.
2. To prevent injury to individuals and damage to the icemaker, do not use ammonia type cleaners.
3. Always wear liquid-proof gloves to prevent the cleaning and sanitizing solutions from coming into contact with skin.

[a] Cleaning Solution

Dilute 4.8 fl. oz. (142 ml) of recommended cleaner Hoshizaki "Scale Away" or "LIME-A-WAY" (Economics Laboratory, Inc.) with 0.8 gallons (3 l) of warm water. This is a minimum amount. Make more solution if necessary.

IMPORTANT

For safety and maximum effectiveness, use the solution immediately after dilution.

[b] Cleaning Procedure

The cleaning process will remove lime deposits from the water system.

- 1) Remove the front panel and top panel, then turn off the power supply.
- 2) Close the water supply line shut-off valve.
- 3) Remove all ice from the storage bin.
- 4) Move the flush switch to the “FLUSH” position.
- 5) Turn on the power supply and drain out all water from the water line.
- 6) Turn off the power supply.
- 7) Remove the strap connecting the spout to the chute assembly.
- 8) Remove the thumbscrews securing the spout and lift it off.
- 9) Pour the cleaning solution over the extruding head until the evaporator assembly and the reservoir are filled and the solution starts to overflow into the drain pan.
Note: If there is excess scale on the extruding head, fill the evaporator assembly and reservoir as described above, then use a clamp on the reservoir hose between the reservoir and evaporator assembly to block flow. Pour additional cleaning fluid over the extruding head until the evaporator assembly is completely full.
- 10) Replace the spout and strap in their correct positions.
- 11) Allow the icemaker to sit for about 10 minutes before operation. If you placed a clamp on the reservoir hose in step 9, remove it before operation.
- 12) Move the flush switch to the “ICE” position, then turn on the power supply. Replace the top panel and front panel in their correct positions. Make ice using the solution until the icemaker stops making ice.
- 13) Remove the front panel.
- 14) Move the flush switch to the “FLUSH” position to drain the remainder of the solution.
- 15) After the solution is drained, move the flush switch to the “ICE” position.
- 16) Replace the front panel in its correct position.
- 17) Open the water supply line shut-off valve and supply water to the reservoir.
- 18) When the gear motor starts, remove the front panel and turn off the power supply.
- 19) Drain out all water from the water line. See 4) through 6).

[c] Sanitizing Solution

Dilute 2.5 fl. oz. (74 ml or 5 tbs) of IMS-II Sanitizer or a 5.25% sodium hypochlorite solution (chlorine bleach) with 5 gallons (19 l) of warm water.

IMPORTANT

For safety and maximum effectiveness, use the solution immediately after dilution.

[d] Sanitizing Procedure - Initial

The sanitizing process will sanitize the icemaker.

- 1) Close the water supply line shut-off valve.
- 2) Remove the strap connecting the spout to the chute assembly.
- 3) Remove the thumbscrews securing the spout and lift it off. Remove the rubber O-ring and nylon O-ring at the top of the cylinder and also remove the packing between the spout and the chute.
- 4) Pour the sanitizing solution over the extruding head until the evaporator assembly and the reservoir are filled and the solution starts to overflow into the drain pan.
- 5) Remove the two thumbscrews securing the proximity switch to the chute assembly.
- 6) Remove the chute assembly from the icemaker.
- 7) Remove the packing at the bottom of the ice chute.
- 8) Remove the three ties and the chute insulation.
- 9) Remove the six wing nuts and two baffles.
- 10) Remove the two thumbscrews, the plate and the packing from the top of the ice chute, then remove the bin control assembly by sliding it slightly toward the chute opening and lifting it off.
- 11) Disassemble the bin control assembly by removing the two snap pins, shaft and actuator.
- 12) Soak the removed parts in .25 gallons (1 l) of sanitizing solution for 10 minutes then wipe them down.
- 13) Rinse the parts thoroughly.

IMPORTANT

If the solution is left on these parts, they will rust.

- 14) Replace all parts in their correct positions.

IMPORTANT

When installing the baffles, make sure that the bent surface (the one without the studs) faces the actuator so that the bent surface can guide the ice to the center of the actuator.

- 15) Move the flush switch to the “ICE” position, then turn on the power supply. Replace the top panel and front panel in their correct positions. Make ice using the solution until the icemaker stops making ice.

[e] Sanitizing Procedure - Final

- 1) Remove the front panel and top panel, then turn off the power supply.
- 2) Move the flush switch to the “FLUSH” position.
- 3) Turn on the power supply and drain out all water from the water line.
- 4) Turn off the power supply.
- 5) Remove the strap connecting the spout to the chute assembly.
- 6) Remove the thumbscrews securing the spout and lift it off.
- 7) Pour the sanitizing solution over the extruding head until the evaporator assembly and the reservoir are filled and the solution starts to overflow into the drain pan.
- 8) Replace the spout and strap in their correct positions.
- 9) Allow the icemaker to sit for about 10 minutes before operation.
- 10) Move the flush switch to the “ICE” position, then turn on the power supply. Replace the top panel and front panel in their correct positions. Make ice using the solution until the icemaker stops making ice.
- 11) Remove the front panel.
- 12) Move the flush switch to the “FLUSH” position to drain the remainder of the solution.
- 13) After the solution is drained, move the flush switch to the “ICE” position.
- 14) Replace the front panel in its correct position.
- 15) Open the water supply line shut-off valve and supply water to the reservoir.

- 16) When the gear motor starts, remove the front panel and turn off the power supply.
- 17) Drain out all water from the water line. See 2) and 3).
- 18) Move the flush switch to the "ICE" position and run the icemaker.
- 19) Turn off the power supply after 30 minutes.
- 20) Pour warm water into the storage bin to melt all ice, and then clean the bin liner with the solution.
- 21) Flush out any solution from the storage bin.
- 22) Turn on the power supply and start the automatic icemaking process.

IMPORTANT

1. After cleaning, do not use ice made from the sanitizing solution. Be careful not to leave any solution in the storage bin.
2. Follow carefully any instructions provided with the bottles of cleaning or sanitizing solution.
3. Never run the icemaker when the reservoir is empty.

2. Maintenance Instructions

IMPORTANT

1. This icemaker must be maintained individually, referring to the instruction manual and labels provided with the icemaker.
2. To have the optimum performance of this icemaker, the following consumable parts need periodic inspection, maintenance and replacement:
 - Extruding Head
 - Housing
 - Gear Motor
 - Auger
 - Mechanical Seal

These parts should be inspected at least once a year or every 10,000 hours of operation. Their service life, however, depends on water quality and environment. More frequent inspection and maintenance are recommended.

Consult with your local distributor about inspection and maintenance service. To obtain the name and phone number of your local distributor, call Hoshizaki Technical Support at 1-800-233-1940 in the USA.

1) Stainless Steel Exterior

To prevent corrosion, wipe the exterior occasionally with a clean and soft cloth. Use a damp cloth containing a neutral cleaner to wipe off oil or dirt build up.

2) Storage Bin and Scoop

- Wash your hands before removing ice. Use the plastic scoop provided (accessory).
- The storage bin is for ice use only. Do not store anything else in the bin.
- Keep the scoop clean. Clean using a neutral cleaner and rinse thoroughly.
- Clean the bin liner using a neutral cleaner. Rinse thoroughly after cleaning.

3) Air Filter

A plastic mesh air filter removes dirt or dust from the air, and keeps the condenser from getting clogged. As the filter gets clogged, the icemaker's performance will be reduced. Check the filter at least twice a month. When clogged, use warm water and a neutral cleaner to wash the filter.

4) Condenser (except water-cooled model)

Check the condenser once a year, and clean if required by using a brush or vacuum cleaner. More frequent cleaning may be required depending on the location of the icemaker.

HOSHIZAKI AMERICA, INC.

618 Hwy. 74 S., Peachtree City, GA 30269 USA | TEL (770) 487-2331 | FAX (770) 487-3360 | www.hoshizaki.com | 91A2LA10D