



# HOSHIZAKI

## Instruction Manual

Self-Contained Flaker

Models

F-330BAK(-C)



**⚠ WARNING**

Only qualified service technicians should install and service the appliance. To obtain the name and phone number of your local Hoshizaki Certified Service Representative, visit [www.hoshizakiamerica.com](http://www.hoshizakiamerica.com). No installation, operation, maintenance, or service should be undertaken until the technician has thoroughly read this Instruction Manual. No service should be undertaken until the technician has thoroughly read the service manual available at [www.hoshizakiamerica.com](http://www.hoshizakiamerica.com). Likewise, the owner/manager should not proceed to operate the appliance until the installer has instructed them on its proper operation. Failure to install, operate, and maintain the appliance in accordance with this manual will adversely affect safety, performance, component life, and warranty coverage and may result in costly water damage. Proper installation is the responsibility of the installer. Product failure or property damage due to improper installation is not covered under warranty.

Hoshizaki provides this manual primarily to assist qualified service technicians in the installation, operation, maintenance, and service of the appliance.

Should the reader have any questions or concerns which have not been satisfactorily addressed, please call, send an e-mail message, or write to the Hoshizaki Technical Support Department for assistance.

Phone: 1-800-233-1940; (770) 487-2331

E-mail: [tech-support@hoshizaki.com](mailto:tech-support@hoshizaki.com)

**HOSHIZAKI AMERICA, INC.**

618 Highway 74 South  
Peachtree City, GA 30269  
Attn: Hoshizaki Technical Support Department

**NOTE:** To expedite assistance, all correspondence/communication **MUST** include the following information:

- Model Number \_\_\_\_\_
- Serial Number \_\_\_\_\_
- Complete and detailed explanation of the problem.

## **IMPORTANT**

This manual should be read carefully before the appliance is installed and operated. Read the warnings and guidelines contained in this manual carefully as they provide essential information for the continued safe use and maintenance of the appliance. Retain this manual for any further reference that may be necessary.

## **CONTENTS**

Important Safety Information .....	4
I. Specifications.....	9
A. Electrical and Refrigerant Data .....	9
B. Dimensions/Connections .....	10
II. Installation and Operating Instructions .....	11
A. Location .....	11
B. Checks Before Installation.....	13
C. How to Remove Panels .....	13
D. Setup.....	14
E. Electrical Connection .....	15
F. Water Supply and Drain Connections .....	16
G. Final Checklist .....	18
1. Pre-Startup .....	18
2. Post-Startup.....	18
III. Operating Instructions.....	19
A. Important Notes About Usage.....	19
B. Startup .....	20
C. Bin Control Check .....	21
D. Alarm Safeties .....	23
IV. Maintenance .....	24
A. User Maintenance Schedule .....	24
B. Service Maintenance Schedule.....	25
C. Cleaning and Sanitizing Instructions.....	26
V. Preparing the Appliance for Periods of Non-Use .....	30
VI. Decommissioning and Disposal .....	31

## Important Safety Information

Throughout this manual, notices appear to bring your attention to situations which could result in death, serious injury, damage to the appliance, or damage to property.

	<b>R-290 Class A3 Flammable Refrigerant Used</b>
<b>⚠ DANGER</b>	Indicates a hazardous situation that, if not avoided, will result in death or serious injury.
<b>⚠ WARNING</b>	Indicates a hazardous situation that, if not avoided, could result in death or serious injury.
<b>NOTICE</b>	Indicates a situation that, if not avoided, could result in damage to the appliance or property.
<b>IMPORTANT</b>	Indicates important information about the use and care of the appliance.

### ⚠ DANGER

#### **Risk of Fire or Explosion** **Flammable Refrigerant Used**

- |   |   |
|---|---|
| <ul style="list-style-type: none"> <li>• Only qualified service technicians should install and service the appliance.</li> <li>• No installation, operation, or maintenance should be undertaken until the technician has thoroughly read this Instruction Manual. All safety precautions must be followed.</li> <li>• No service should be undertaken until the technician has thoroughly read the Service Manual available at <a href="http://www.hoshizakiamerica.com">www.hoshizakiamerica.com</a>. All safety precautions must be followed.</li> <li>• This appliance to be installed in accordance with the Safety Standard for Refrigeration Systems ANSI/ASHRAE 15.</li> <li>• Follow handling instructions carefully in compliance with national regulations.</li> <li>• Do not use mechanical devices or other means to accelerate the defrosting process or to clean, other than those recommended by the manufacturer.</li> <li>• Do not puncture refrigerant tubing. Risk of fire or explosion due to puncture of refrigerant tubing; follow handling instructions carefully.</li> </ul> | <ul style="list-style-type: none"> <li>• Servicing shall be done by trained service personnel with certified competence in handling flammable refrigerants to minimize the risk of possible ignition due to incorrect parts or improper service.</li> <li>• Component parts shall be replaced with like components. so as to minimize the risk of possible ignition due to incorrect parts.</li> <li>• Dispose of properly in accordance with federal or local regulations.</li> <li>• Do not pierce or burn.</li> <li>• Be aware that refrigerants may not contain an odor.</li> <li>• Do not damage the refrigeration circuit.</li> <li>• See nameplate for R-290 refrigerant charge:             <ul style="list-style-type: none"> <li>• If greater than 114 g (4 oz.), do not install in public corridor or lobby.</li> <li>• If greater than 152 g (5.3 oz.), do not install within 6 m (20 ft) of open flame.</li> </ul> </li> <li>• The appliance shall be stored in a room without continuously operating ignition sources (for example: open flames, an operating gas appliance, or an operating electric heater).</li> </ul> |
|---|---|

**⚠ DANGER continued**

- Do not place any potential ignition sources in or near the appliance.
- Keep clear of obstruction all ventilation openings in the appliance enclosure or in the structure for building-in.
- No potential sources of ignition are to be used in the searching for or detection of refrigerant leaks.
- Do not use electrical appliances inside the appliance unless they are of the type recommended by the manufacturer.
- Do not store explosive substances such as aerosol cans with a flammable propellant in this appliance.
- Check that cabling will not be subject to wear, corrosion, excessive pressure, vibration, sharp edges, or any other adverse environmental effects. The check shall also take into account the effects of aging or continual vibration from sources such as compressors or fans.
- Ensure that the area is in the open or that it is adequately ventilated before breaking into the system or conducting any hot work. A degree of ventilation shall continue during the period that the work is carried out. The ventilation should safely disperse any released refrigerant and preferably expel it externally into the atmosphere.

**Risque D'Incendie ou D'Explosion  
Fluide Frigorigène Inflammable Utilisé**

- Seuls des techniciens de service qualifiés doivent installer et entretenir l'appareil.
- Aucune installation, opération ou maintenance ne doit être entreprise avant que le technicien n'ait lu attentivement ce manuel d'instructions. Toutes les précautions de sécurité doivent être suivies.
- Aucune opération d'entretien ne doit être entreprise avant que le technicien n'ait lu attentivement le manuel d'entretien disponible sur le site [www.hoshizakiamerica.com](http://www.hoshizakiamerica.com). Toutes les précautions de sécurité doivent être suivies.
- Cet appareil doit être installé conformément à la norme de sécurité pour les systèmes de réfrigération ANSI/ASHRAE 15.
- Suivez attentivement les instructions de manutention conformément aux règlements nationaux.
- Ne pas utiliser de dispositifs mécaniques ou d'autres moyens pour accélérer le processus de dégivrage ou pour nettoyer, autres que ceux recommandés par le fabricant.
- Ne pas perforer la conduite de fluide frigorigène. Risque d'incendie ou d'explosion en cas de perforation d'une canalisation de fluide frigorigène; suivez attentivement les instructions de manutention.
- L'entretien doit être effectué par du personnel formé et certifié pour la manipulation de réfrigérants inflammables afin de réduire au minimum le risque d'inflammation dû à des pièces incorrectes ou à un entretien inadéquat.

**⚠ DANGER continued**

- Les pièces doivent être remplacées par des pièces similaires, de manière à réduire au minimum le risque d'inflammation dû à des pièces incorrectes.
  - Mettre au rebut conformément aux règlements fédéraux ou locaux.
  - Ne pas percer ou brûler.
  - Attention, les fluides frigorigènes peuvent ne pas dégager d'odeur.
  - Ne pas endommager les composants du circuit de réfrigération.
  - Voir plaque signalétique pour la charge de réfrigérant R-290:
    - Si elle est supérieure à 114 g (4 oz.), ne pas l'installer dans un couloir public ou un hall d'entrée.
    - Si elle est supérieure à 152 g (5.3 oz.), ne pas l'installer à moins de 6 m (20 pi) d'une flamme nue.
  - L'appareil doit être entreposé dans un local ne contenant pas de sources d'inflammation permanentes (flammes nues, appareil à gaz ou dispositif de chauffage électrique en fonctionnement, par exemple).
  - Ne placer aucune source d'inflammation potentielle à l'intérieur ou à proximité de l'appareil.
  - Ne pas obstruer les ouvertures de ventilation dans l'enceinte de l'appareil ou dans la structure d'encastrement.
  - Aucune source potentielle d'inflammation ne doit être utilisée pour rechercher ou détecter des fuites de réfrigérant.
  - Ne pas utiliser d'appareils électriques à l'intérieur de l'appareil, sauf s'ils sont du type recommandé par le fabricant.
  - Ne pas entreposer dans cet appareil des substances explosives telles que des bombes aérosols contenant un gaz propulseur inflammable.
- Vérifier que le câblage ne sera pas soumis à l'usure, à la corrosion, à une pression excessive, à des vibrations, à des arêtes vives ou à tout autre effet environnemental négatif. Le contrôle doit également prendre en compte les effets du vieillissement ou des vibrations continues provenant de sources telles que les compresseurs ou les ventilateurs.
  - S'assurer que la zone est à l'air libre ou qu'elle est correctement ventilée avant de pénétrer dans le système ou d'effectuer un travail à chaud. Une certaine ventilation doit être maintenue pendant la durée des travaux. La ventilation doit permettre de disperser en toute sécurité tout réfrigérant libéré et, de préférence, de l'expulser dans l'atmosphère.

## WARNING

The appliance should be destined only to the use for which it has been expressly conceived. Any other use should be considered improper and therefore dangerous. The manufacturer cannot be held responsible for injury or damage resulting from improper, incorrect, and unreasonable use. Failure to install, operate, and maintain the appliance in accordance with this manual will adversely affect safety, performance, component life, and warranty coverage and may result in costly water damage. **To reduce the risk of death, electric shock, serious injury, or fire, follow basic precautions including the following:**

- This appliance is not intended for use above 2,000 m (6,561 ft). Installation above 2,000 m (6,561 ft) may adversely affect safety, performance, and component life.
- Wear appropriate personal protective equipment (PPE) when servicing the appliance.
- The appliance must be installed in accordance with applicable national, state, and local codes and regulations.
- The appliance requires an independent power supply of proper capacity. See the nameplate for electrical specifications. Failure to use an independent power supply of proper capacity can result in a tripped breaker, blown fuse, damage to existing wiring, or component failure. This could lead to heat generation or fire.

- **THE APPLIANCE MUST BE GROUNDED.** The appliance is equipped with a NEMA 5-15 three-prong grounding plug  to reduce the risk of potential shock hazards. It must be plugged into a properly grounded, independent 3-prong wall outlet. If the outlet is a 2-prong outlet, it is your personal responsibility to have a qualified electrician replace it with a properly grounded, independent 3-prong wall outlet. Do not remove the ground prong from the power cord and do not use an adapter plug. Failure to follow these instructions may result in death, electric shock, or fire.
- To reduce the risk of electric shock, do not touch the control switch or plug with damp hands.
- To reduce the risk of electric shock, make sure the control switch is in the "OFF" position before plugging in or unplugging the appliance.
- Unplug the appliance before servicing.
- Do not use an appliance with a damaged power cord. The power cord should not be altered, jerked, bundled, weighed down, pinched, or tangled. Such actions could result in electric shock or fire. To unplug the appliance, be sure to pull the plug, not the cord, and do not jerk the cord.
- Do not use an extension cord.
- If the supply cord is damaged, it must be replaced by the manufacturer, its service agent, or similarly qualified persons in order to avoid a hazard. Upon replacement, the GREEN ground wire in the power cord must be connected to the designated grounding screw.
- Do not make any alterations to the appliance. Alterations could result in electric shock, injury, fire, or damage to the appliance.
- Appliance is heavy. Use care when lifting or positioning. Work in pairs when needed to prevent injury or damage.

**⚠ WARNING continued**

- The appliance is not intended for use by persons (including children) with reduced physical, sensory, or mental capabilities, or lack of experience and knowledge, unless they have been given supervision or instruction concerning use of the appliance by a person responsible for their safety.
- Do not splash, pour, or spray water directly onto or into the appliance. This might cause short circuit, electric shock, corrosion, or failure.
- Children should be supervised to ensure that they do not play with the appliance.
- Do not climb, stand, or hang on the appliance or allow children or animals to do so. Serious injury could occur or the appliance could be damaged.
- Be careful not to pinch fingers when opening and closing the door. Be careful when opening and closing the door when children are in the area.
- Do not use combustible spray or place volatile or flammable substances in or near the appliance. They might catch fire.
- Keep the area around the appliance clean. Dirt, dust, or insects in the appliance could cause harm to individuals or damage to the appliance.

**NOTICE**

- Follow the water supply, drain connection, and maintenance instructions carefully to reduce the risk of costly water damage.
- In areas where water damage is a concern, install in a contained area with a floor drain.
- Install the appliance in a location that stays above freezing. Normal operating ambient temperature must be within 45°F to 100°F (7°C to 38°C).

**NOTICE**

- To help ensure that the ice storage bin drain remains clear, follow the instructions in "IV.C. Ice Storage Bin Drain" once every 3 months or as often as necessary for conditions. If the ice storage bin drain becomes clogged, water could build up in the bin and overflow, leading to costly water damage.
- Do not leave the appliance on during extended periods of non-use, extended absences, or in sub-freezing temperatures. To properly prepare the appliance for these occasions, follow the instructions in "V. Preparing the Appliance for Periods of Non-Use."
- If water collects in the bin and will not drain, turn off the appliance and close the water supply line shut-off valve. Call for service.
- If water seeps from the base of the appliance, turn off the appliance and close the water supply line shut-off valve. Call for service. Failure to do so could lead to costly water damage.
- Do not place objects on top of the appliance.
- The ice storage bin is for ice use only. Do not store anything else in the ice storage bin.
- Protect the floor when moving the appliance to prevent damage to the floor.
- Do not allow the appliance to bear any outside weight.

---

## I. Specifications

### A. Electrical and Refrigerant Data

The nameplate provides electrical and refrigerant data and Year of Manufacture (YOM). The nameplate is located inside the ice storage bin. For certification marks, see the nameplate.

We reserve the right to make changes in specifications and design without prior notice.

Model Number	F-330 BAK	F-330 BAK-C
AC SUPPLY VOLTAGE	~115/60/1	115/60/1
AMPERES	6.3	6.3
DESIGN PRESSURE kPa (PSI)	HI-2730 (396) LO-1310 (190)	HI-2730 (396) LO-1310 (190)
REFRIGERANT g (oz.)	R-290 78 (2.8)	R-290 78 (2.8)
CLIMATIC CLASS	5	5
INSULATION BLOWING GAS	HFO 1233zd(E)	HFO 1233zd(E)
MINIMUM ROOM FLOOR AREA m <sup>2</sup> (ft <sup>2</sup> )	3.7 (40.2)	3.7 m <sup>2</sup> (40.2 ft <sup>2</sup> )
HARVEST RATE	≤1,200 LB/DAY (CONTINUOUS)	≤1,200 LB/DAY (CONTINUOUS)

Note: Climatic Class 5: This appliance electrical safety tested for operation in maximum ambient temperature of 104°F (40°C) with 40% relative humidity. However, normal operating ambient temperature must be within 45°F to 100°F (7°C to 38°C); Normal operating water temperature must be within 45°F to 100°F (7°C to 38°C). Operation of the appliance, for extended periods, outside of these normal temperature ranges may affect appliance performance.

# B. Dimensions/Connections

## 1. F-330 BAK(-C)

Unit: in. (mm)

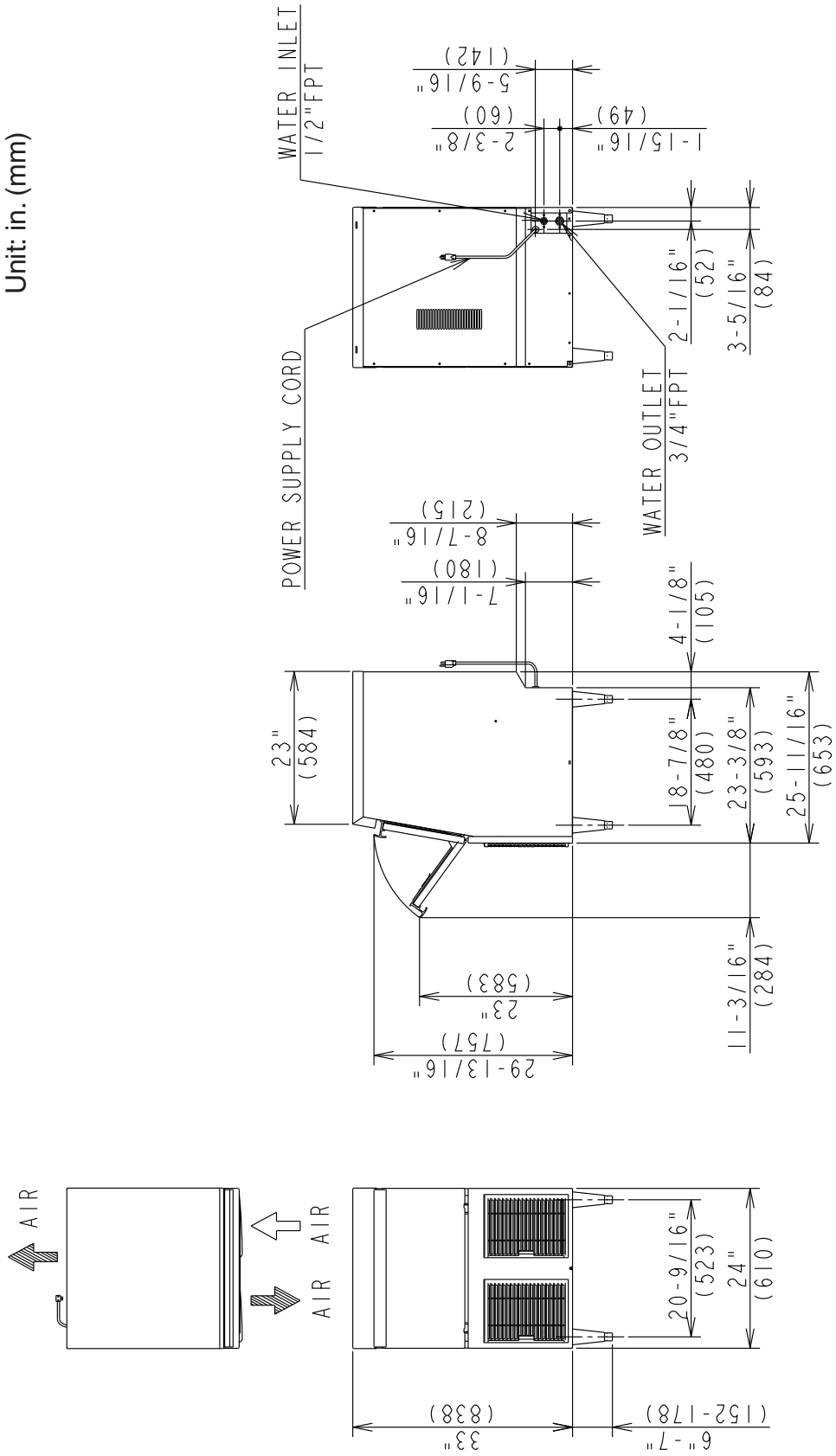

## II. Installation and Operating Instructions



### WARNING

- This appliance must be installed in accordance with applicable national, state, and local codes and regulations.
- This appliance to be installed in accordance with the Safety Standard for Refrigeration Systems ANSI/ASHRAE 15.
- Failure to install, operate, and maintain the appliance in accordance with this manual will adversely affect safety, performance, component life, and warranty coverage and may result in costly water damage.
- **CHOKING HAZARD:** Ensure all components, fasteners, and thumbscrews are securely in place after installation. Make sure that none have fallen into the ice storage bin.

### A. Location

#### 1. General

This appliance uses an A3 flammable refrigerant. For refrigerant charge and minimum room floor area, see the table below.

 DANGER		
	<b>R-290 Class A3 Flammable Refrigerant Used</b>	
Model	R-290 Refrigerant Charge g (oz.)	Minimum Room Floor Area (operating or storage) Superficie Minimale du Local (service ou stockage) m <sup>2</sup> (ft <sup>2</sup> ); m <sup>2</sup> (pi <sup>2</sup> )
F-330BAK(-C)	78 (2.8)	3.7 (40.2)
		
≥ Area m <sup>2</sup> (ft <sup>2</sup> ) (see "Minimum Room Floor Area" above) ≥ Superficie m <sup>2</sup> (pi <sup>2</sup> ) (voir « Superficie Minimale du Local » ci-dessus)		

**⚠ DANGER continued**

**R-290 Refrigerant Charge:**

- If greater than 114 g (4 oz.), do not install in public corridor or lobby.
- If greater than 152 g (5.3 oz.), do not install within 6 m (20 ft) of open flame.

**Charge de réfrigérant R-290:**

- Si elle est supérieure à 114 g (4 oz.), ne pas l'installer dans un couloir public ou un hall d'entrée.
- Si elle est supérieure à 152 g (5.3 oz.), ne pas l'installer à moins de 6 m (20 pi) d'une flamme nue.

This appliance is not intended for use above 2,000 m (6,561 ft). Installation above 2,000 m (6,561 ft) may adversely affect safety, performance, and component life.

**NOTICE**

- This appliance is not intended for outdoor use. Normal operating ambient temperature must be within 45°F to 100°F (7°C to 38°C); Normal operating water temperature must be within 45°F to 95°F (7°C to 35°C). Operation of the appliance, for extended periods, outside of these normal temperature ranges may affect appliance performance.
- This appliance will not work at sub-freezing temperatures. To prevent damage to the water supply line, drain the appliance if the air temperature is going to go below 32°F (0°C). See "V. Preparing the Appliance for Periods of Non-Use."

- The appliance should not be located next to ovens, grills, or other high heat producing equipment.
- The location must provide a firm foundation for the appliance.
- This appliance requires no side or top clearance. But allow enough space at rear for water supply and drain connections and at least 15" (38 cm) clearance at front.
- The appliance must be at floor level on a finished floor even if under a cabinet. In areas where water damage is a concern, install in a contained area with a floor drain.

## B. Checks Before Installation

- Visually inspect the exterior of the shipping container and immediately report any damage to the carrier. Upon opening the container, any concealed damage should also be immediately reported to the carrier.
- Remove the shipping carton, tape, and packing material. If any are left in the appliance, it will not work properly.
- See the nameplate on the rear panel, and check that your voltage supplied corresponds with the voltage specified on the nameplate.
- Remove the package containing the accessories.
- Remove the protective plastic film from the panels. If the appliance is exposed to the sun or to heat, remove the film after the appliance cools.
- Check that the refrigerant lines do not rub or touch lines or other surfaces, and that the fan blade turns freely.
- Check that the compressor is snug on all mounting pads.

## C. How to Remove Panels

See Fig. 1

- Front Panel: Remove the screw. Lift up and towards you.
- Top Panel: Open the door. Remove the screws. Lift up at the front slightly, push rearward, and lift off.

**Notice! The F-330 BAK(-C) utilizes 1 air filter in the right side louver.**

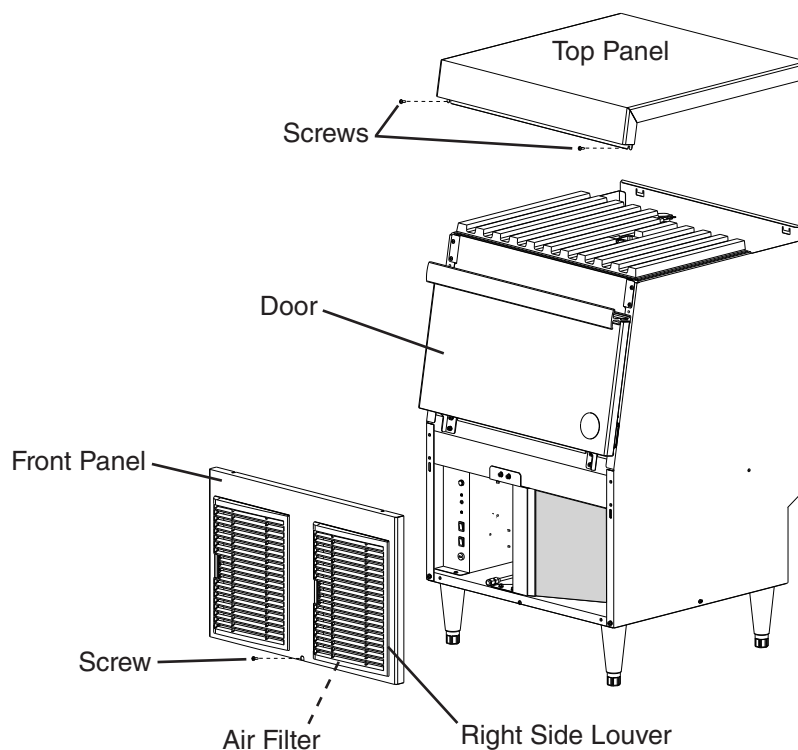

**Fig. 1**

## **D. Setup**

- 1) Attach the four adjustable legs provided to the bottom of the appliance.
- 2) Position the appliance in the selected permanent location.
- 3) Level the appliance from side-to-side and front-to-rear by adjusting the legs.

## E. Electrical Connection

### **WARNING**

- Electrical connection must meet national, state, and local electrical code requirements. Failure to meet these code requirements could result in death, electric shock, serious injury, fire, or damage.
  - The appliance requires an independent power supply of proper capacity. See the nameplate for electrical specifications. Failure to use an independent power supply of proper capacity can result in a tripped breaker, blown fuse, damage to existing wiring, or component failure. This could lead to heat generation or fire.
  - **THE APPLIANCE MUST BE GROUNDED:** The appliance is equipped with a NEMA 5-15 three-prong grounding plug  to reduce the risk of potential shock hazards. It must be plugged into a properly grounded, independent 3-prong wall outlet. If the outlet is a 2-prong outlet, it is your personal responsibility to have a qualified electrician replace it with a properly grounded, independent 3-prong wall outlet. Do not remove the ground prong from the power cord and do not use an adapter plug. Failure to properly ground the appliance could result in death or serious injury.
  - Do not use an extension cord.
  - To reduce the risk of electric shock, do not touch the power switch or plug with damp hands.
  - To reduce the risk of electric shock, make sure the power switch is in the "OFF" position before plugging in or unplugging the appliance.
  - Do not use an appliance with a damaged power cord. The power cord should not be altered, jerked, bundled, weighed down, pinched, or tangled. Such actions could result in electric shock or fire. To unplug the appliance, be sure to pull the plug, not the cord, and do not jerk the cord.
  - If the supply cord is damaged, it must be replaced by the manufacturer, its service agent, or similarly qualified persons in order to avoid a hazard. Upon replacement, the GREEN ground wire in the power cord must be connected to the designated grounding screw.
- Usually an electrical permit and services of a licensed electrician are required.
  - The maximum allowable voltage variation is  $\pm 10$  percent of the nameplate rating.

## F. Water Supply and Drain Connections

See Fig. 2

### **⚠ WARNING**

- Water supply and drain connections must be installed in accordance with applicable national, state, and local regulations.
- Connect to potable water supply only. Do not connect to a hot-water supply.

### **NOTICE**

- Normal operating water temperature must be within 45°F to 90°F (7°C to 32°C). Operation of the appliance, for extended periods, outside of this normal temperature range may affect appliance performance.
- Water supply pressure must be a minimum of 10 PSIG (69 kPa) and a maximum of 113 PSIG (779 kPa). If the pressure exceeds 113 PSIG (779 kPa), the use of a pressure reducing valve is required.
- External filters, strainers, or softeners may be required depending on water quality. Contact your local Hoshizaki Certified Service Representative or local Hoshizaki distributor for recommendations.
- In areas where water damage is a concern, install in a contained area with a floor drain.
- Water line installation to the appliance is not warranted by Hoshizaki.
- Water-hammer issues must be resolved by a qualified plumber before installing the appliance. Water hammer can cause appliance damage that may lead to water leakage or flooding.
- A minimum of 3/4" nominal ID hard pipe or equivalent is required for the drain line. Installing a smaller diameter drain line will reduce water flow and may lead to water leakage or flooding.
- Be sure there is sufficient extra water supply line and drain line for the appliance to be pulled out for service.

<b>Water Supply Inlet</b>	<b>Minimum Water Supply Line Size</b>	<b>Drain Outlet</b>	<b>Minimum Drain Line Size</b>
1/2" Female Pipe Thread (FPT)	1/4" Nominal ID Copper Water Tubing or Equivalent	3/4" Female Pipe Thread (FPT)	3/4" Nominal ID Hard Pipe or Equivalent

- A plumbing permit and services of a licensed plumber may be required in some areas.
- Water supply line size is critical to the operation of the appliance. Failure to provide adequate water supply to the appliance may result in damage to the appliance, damage to property, and may void the warranty.

- A water supply line shut-off valve and drain valve must be installed.
- Water supply pressure must be a minimum of 10 PSIG (69 kPa) and a maximum of 113 PSIG (779 kPa). If the pressure exceeds 113 PSIG (779 kPa), the use of a pressure reducing valve is required.
- Drain lines must have 1/4" fall per foot (2 cm per 1 m) on horizontal runs to get a good flow. A vented tee connection is also required for proper flow.
- Drain line should not be piped directly to the sewer system. An air gap of a minimum of 2 vertical inches (5 cm) must be between the end of the drain pipe from the appliance and the floor drain.

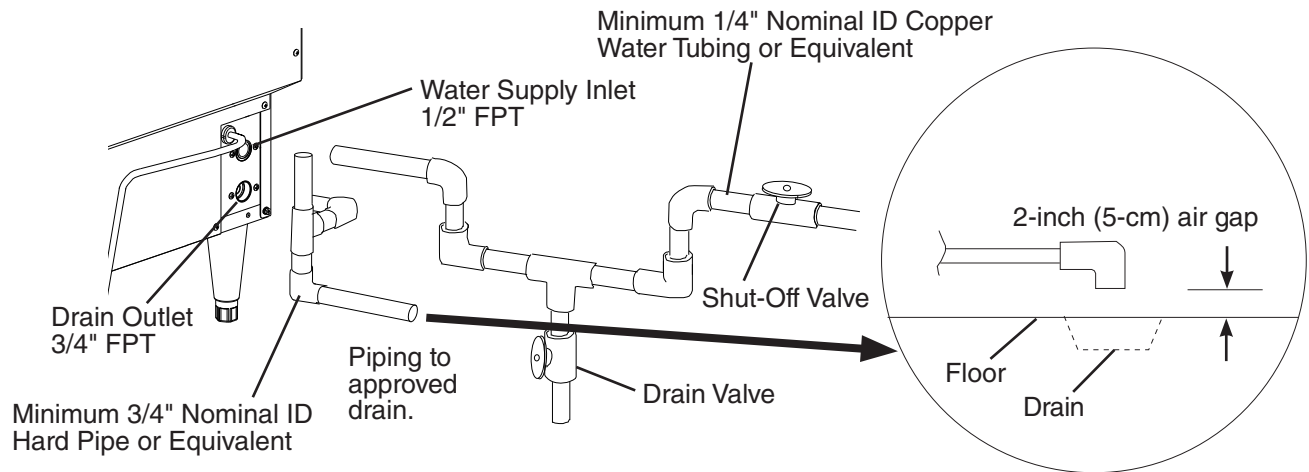

**Fig. 2**

## G. Final Checklist

### 1. Pre-Startup

- 1) Is the appliance level?
- 2) Is the appliance in a site where the ambient temperature is within 45°F to 100°F (7°C to 38°C) and the water temperature within 45°F to 90°F (7°C to 32°C) all year around?
- 3) Is there at least 6" (15-cm) clearance at rear and sides and 24" (61-cm) at the top of the appliance?
- 4) Have the shipping carton, tape, and packing material been removed from the appliance? Has the protective plastic film been removed from the panels?
- 5) Have all electrical and water connections been made? Do electrical and water connections meet applicable national, state, and local code and regulation requirements?
- 6) Has the power supply voltage been checked or tested against the nameplate rating? Is the power supply a properly grounded, independent 3-prong wall outlet?
- 7) Are the water supply and drain lines sized as specified? Are the water supply line shut-off valve(s) and drain valve(s) installed? Has the water supply pressure been checked to ensure a minimum of 10 PSIG (69 kPa) and a maximum of 113 PSIG (779 kPa)?
- 8) Are all components, fasteners, and thumbscrews securely in place?
- 9) Is the compressor snug on all mounting pads? Have the refrigerant lines been checked to make sure they do not rub or touch other lines or surfaces? Has the fan blade (if applicable) been checked to make sure it turns freely?
- 10) Continue to "III.B. Startup."

### 2. Post-Startup

<b>⚠ WARNING</b>
<b>CHOKING HAZARD:</b> Ensure all components, fasteners, and thumbscrews are securely in place after installation. Make sure that none have fallen into the ice storage bin.

- 1) Has the bin control operation been confirmed?
- 2) Has the ice and water dispenser operation been confirmed?
- 3) Are all components, fasteners, and thumbscrews securely in place?
- 4) Has the end user been given the instruction manual, and instructed on how to operate the appliance and the importance of the recommended periodic maintenance?
- 5) Has the end user been given the contact information of an authorized service agent?
- 6) Has the warranty card been filled out and forwarded to the factory for warranty registration?

### III. Operating Instructions



#### R-290 Class A3 Flammable Refrigerant Used

#### **⚠ DANGER**

##### **Risk of Fire or Explosion Flammable Refrigerant Used**

- Be sure to follow all Important Safety Information located at the beginning of this manual.
- Failure to install, operate, and maintain the appliance in accordance with this manual will adversely affect safety, performance, component life, and warranty coverage and may result in costly water damage.
- Keep clear of obstruction all ventilation openings in the appliance enclosure or in the structure for building-in.

##### **Risque D'Incendie ou D'Explosion. Fluide Frigorigène Inflammable Utilisé.**

- Veuillez à respecter toutes les consignes de sécurité importantes figurant au début de ce manuel.
- Le fait de ne pas installer, utiliser et entretenir l'appareil conformément à ce manuel aura des conséquences négatives sur la sécurité, les performances, la durée de vie des composants et la couverture de la garantie, et peut entraîner des dégâts des eaux coûteux.
- Ne pas obstruer les ouvertures de ventilation dans l'enceinte de l'appareil ou dans la structure d'encastrement.

### A. Important Notes About Usage

#### **NOTICE**

- Protect the floor when moving the appliance to prevent damage to the floor.
- To help ensure that the ice storage bin drain remains clear, follow the instructions in "IV.C. Ice Storage Bin Drain" once every 3 months or as often as necessary for conditions. If the ice storage bin drain becomes clogged, water could build up in the bin and overflow, leading to costly water damage.
- If water collects in the bin and will not drain, turn off the appliance and close the water supply line shut-off valve. Call for service.
- Do not leave the appliance on during extended periods of non-use, extended absences, or in sub-freezing temperatures. To properly prepare the appliance for these occasions, follow the instructions in "V. Preparing the Appliance for Periods of Non-Use."
- Do not place objects on top of the appliance.
- The ice storage bin is for ice use only. Do not store anything else in the ice storage bin.

## B. Startup

### **⚠ WARNING**

- All parts are factory-adjusted. Improper adjustments may adversely affect safety, performance, component life, and warranty coverage.
- To reduce the risk of electric shock, do not touch the power switch, control switch, or plug (on corded models) with damp hands.
- If you have to slide the appliance back for a built-in installation, make sure you do not damage or pinch the water supply line, drain line, or power cord.

### **NOTICE**

- If the appliance is turned off, wait for at least 3 minutes before restarting the appliance to prevent damage to the compressor.
- At startup, confirm that all internal and external connections are free of leaks.

- 1) Open the water supply line shut-off valve.
- 2) Remove the top and front panels.
- 3) Make sure the power switch is in the "OFF" position.
- 4) Plug the appliance into the electrical outlet.
- 5) Move the control switch to the "ICE" position, then move the power switch to the "ON" position to start the automatic icemaking process. Replace the front and top panels.
- 6) Once the unit starts to produce ice, allow it to run for another 30 min.
- 7) Remove the top and front panels.
- 8) Move the power switch to the "OFF" position, then move the control switch to the "DRAIN" position. Move the power switch to the "ON" position, then replace the front and top panels. Allow the water system to drain for 5 min.
- 9) Remove the top and front panels, then move the power switch to the "OFF" position.
- 10) Unplug the appliance from the electrical outlet.
- 11) Pour warm water into the ice storage bin and melt any remaining ice. Clean the ice storage bin liner using a neutral cleaner. Rinse thoroughly after cleaning.
- 12) Confirm bin control operation. See "II.I. Bin Control Check."

## C. Bin Control Check

A mechanical bin control controls the level of ice in the ice storage bin.

### **IMPORTANT**

- Make sure the appliance has been installed as outlined in this manual and that the water supply is on.
- Make sure S2 dip switch 7 is in the "OFF" position and dip switch 8 is in the "ON" position.

- 1) Remove the top and front panels and the control box cover.
- 2) Make sure the power switch is in the "OFF" position.
- 3) Plug the appliance into the electrical outlet.
- 4) Move the control switch to the "ICE" position, then move the power switch to the "ON" position.
- 5) Make sure the "GM" LED on the control board is on. See Fig. 3. There is a delay of at least 30 seconds before the "GM" LED turns on after power-up. After the "GM" LED turns on, press the "SERVICE" button on the control board to bypass the 5-min. compressor delay. **WARNING! Risk of electric shock. Care should be taken not to touch live terminals.** Confirm the "COMP" LED turns on.  
Note: If the "SERVICE" button is not pressed, the "COMP" LED turns on and compressor energizes 5 min. after gear motor starts.

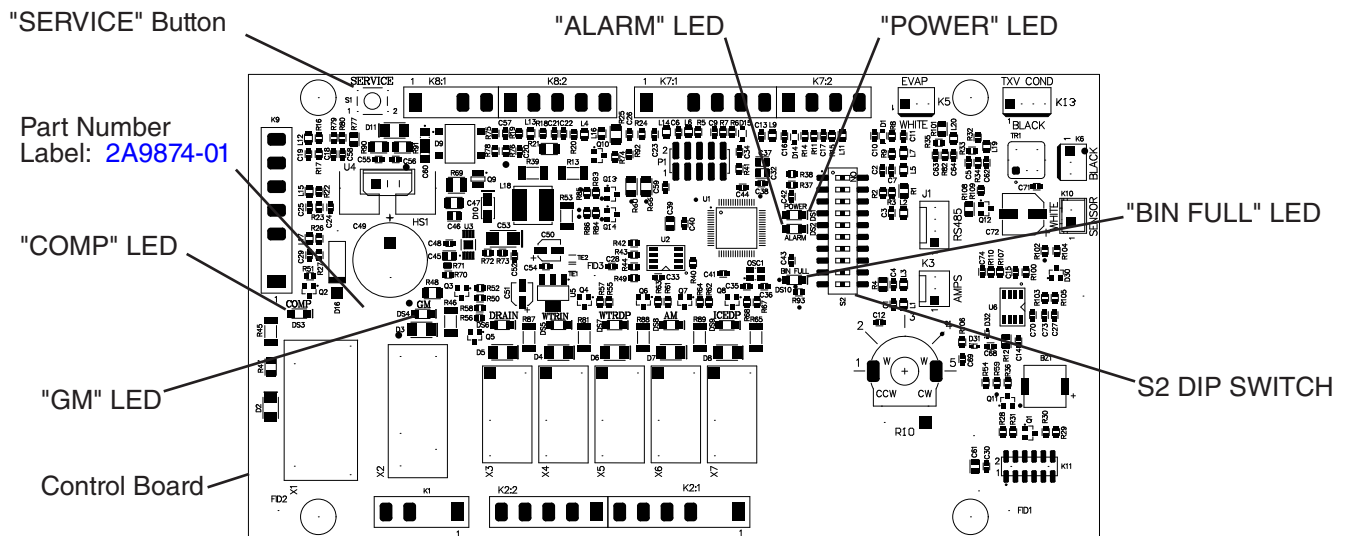

**Fig. 3**

- 6) Once the "COMP" LED is on and compressor is energized, press the actuator paddle located in the ice storage bin (actuator paddle engaged). See Fig. 4. The 90-sec. compressor shutdown timer starts. Once the 90-sec. compressor shutdown timer terminates, compressor and fan motor de-energize and the 60-sec. gear motor shutdown timer starts. Once the 60-sec. gear motor timer terminates, gear motor de-energizes. Release the actuator to start the automatic icemaking process.

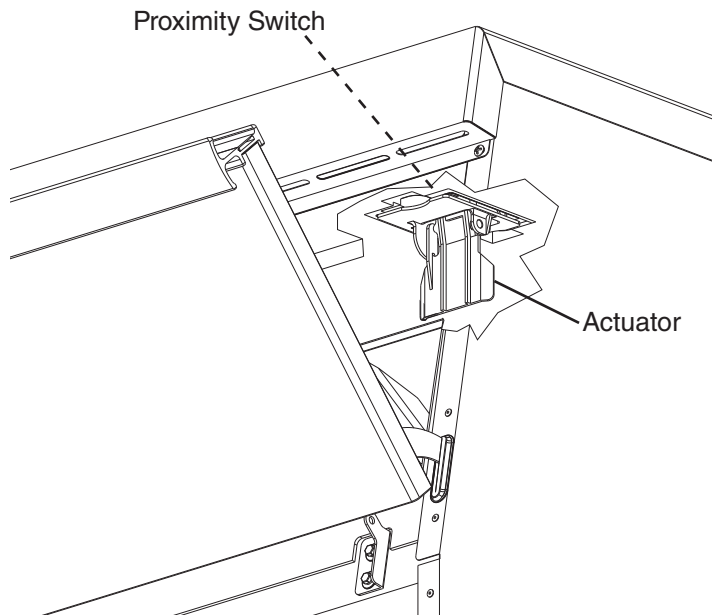

**Fig. 4**

- 7) Move the power switch to the "OFF" position.
- 8) Unplug the appliance from the electrical outlet.
- 9) Replace the control box cover in its correct position.
- 10) Plug the appliance into the electrical outlet.
- 11) Move the control switch to the "ICE" position, then move the power switch to the "ON" position to start the automatic icemaking process.
- 12) Replace the front and top panels.
- 13) Return to "II.G.2. Post Startup."

## D. Alarm Safeties

Should an alarm occur, follow the instructions in the table below to address the alarm. If an alarm continues to occur, contact an authorized service agent.

In case of alarm, the built-in safeties shut down the unit, the orange "ALARM" LED turns on, and audible alarms sound as listed below.

No. of Beeps (every 5 sec.)	Type of Alarm	Notes and Reset Options
1	<b>Low-Water Safety</b> UFS open > 90 sec. after WV energized.	Automatic reset once water supply is restored and UFS closes.
2	<b>Control Switch</b> In "DRAIN" position longer than 15 min.	Automatic reset once the control switch is moved to the "ICE" position.
3	<b>High-Pressure Switch</b> First and second activation in 1 hr.	Automatic reset once pressure drops below the high pressure threshold and the high-pressure switch closes.
4	<b>High-Pressure Switch</b> Third activation in 1 hr.	Turn power off. Call for service. To avoid possible catastrophic failure, it is recommended to leave the icemaker off until this alarm is resolved.
5	<b>Freeze Timer</b> WV off > 30 min. since last WV activation.	Call for service. Manual reset. Turn power off and on again. Check for FS stuck (up), WV leaking by, TXV defective, LLV not opening, low charge, HM not bypassing, or inefficient Comp.
6	<b>Low Voltage</b> 92VAC ± 5% or less.	Green "POWER" LED turns off if voltage protection operates.
7	<b>High Voltage</b> 147VAC ± 5% or more.	Control voltage safeties automatically reset when voltage is corrected.
8	<b>a) Gear Motor Fuse or Protector Open</b> CCR contacts fail to close. <b>Used on all models.</b>	Turn power off. Check for GM fuse or protector open. Replace fuse or let protector cool and reset. If persistent trips occur, call for service.
	<b>b) Evaporator Thermistor</b> At GM startup Evaporator thermistor < -4°F (-20°C). <b>Used on cubelet (-C)(-SC)(-CB) models only.</b>	Turn power off. Call for service. To avoid possible catastrophic failure, it is recommended to leave the icemaker off until this alarm is resolved. Manual reset. Turn power off and on again.
9	<b>Bin Control 2 (Mechanical)</b> Open Circuit Control Board K8 (#3 and #4) <b>Not used on DCM or self-contained models.</b>	Manual reset. Turn power off and on again. <b>Modular Flaker and Cubelet (-C)(-SC)(-CB) Models:</b> Control Board S2 Dip Switch #7 must be ON. <b>DCM and Self-Contained Models:</b> Control Board S2 Dip Switch #7 must be OFF.
10	<b>Evaporator Thermistor</b> Evaporator thermistor reaches -22°F (-30°C) for 3 consecutive cycles. <b>Used on cubelet (-C)(-SC)(-CB) models only.</b>	Turn power off. Call for service. To avoid possible catastrophic failure, it is recommended to leave the icemaker off until this alarm is resolved. Manual reset. Turn power off and on again.

Legend: **Comp**—compressor; **DV**—drain valve; **EH**—evaporator heater; **FM**—fan motor; **FMR**—fan motor-remote; **FS**—float switch; **GM**—gear motor; **HM**—headmaster (C.P.R.); **LLV**—liquid line valve; **SLV**—suction line valve; **TXV**—thermostatic expansion valve; **UFS**—upper float switch; **WV**—inlet water valve

Dip switches are factory set and must be adjusted per the unit's service manual or Hoshizaki Technical Support recommendation.

## IV. Maintenance

The appliance must be maintained in accordance with the instruction manual and labels provided with the appliance. Consult with your local Hoshizaki Certified Service Representative about maintenance service. To obtain the name and phone number of your local Hoshizaki Certified Service Representative, visit [www.hoshizakiamerica.com](http://www.hoshizakiamerica.com).

### WARNING

- Items listed under "IV.A. User Maintenance Schedule" may be performed by the user; otherwise, only qualified service technicians should service the appliance.
- Failure to install, operate, and maintain the equipment in accordance with this manual will adversely affect safety, performance, component life, and warranty coverage.
- To reduce the risk of electric shock, do not touch the icemaker power switch or control switch with damp hands.
- **Before Servicing:** Move the power switch to the "OFF" position, then unplug the appliance from the electrical outlet. Power switch in "OFF" position does not de-energize all loads.
- **CHOKING HAZARD:** Ensure all components, fasteners, and thumbscrews are securely in place after any maintenance is done to the appliance. Make sure that none have fallen into the ice storage bin.
- Do not place fingers or any other objects into the ice discharge opening.
- After service, make sure that there are no wires pinched between the panels and appliance. Make sure you do not damage or pinch the water supply line, drain line, or power cord.

### A. User Maintenance Schedule

The user maintenance schedule below is a guideline. More frequent maintenance may be required depending on water quality, the appliance's environment, and local sanitation regulations.

Maintenance Schedule		
Frequency	Area	Task
Daily	Scoop	Clean the ice scoop using a neutral cleaner. Rinse thoroughly after cleaning.
Bi-Weekly	Air Filters	Inspect. Wash with warm water and neutral cleaner if dirty.
Monthly	Appliance Exterior	Wipe down with a clean, soft cloth. Use a damp cloth containing a neutral cleaner to wipe off oil or dirt build up. Clean any chlorine staining (rust colored spots) using a non-abrasive cleanser.

## B. Service Maintenance Schedule

The service maintenance schedule below is a guideline; service maintenance items are to be performed by qualified service technicians only. More frequent maintenance may be required depending on water quality, the appliance's environment, and local sanitation regulations.

Maintenance Schedule		
Frequency	Area	Task
Monthly	External Water Filters	Check for proper pressure and change if necessary.
Every 6 Months	Icemaker and Ice Storage Bin	Clean and sanitize per the cleaning and sanitizing instructions provided in this manual. See "III.B. Cleaning and Sanitizing Instructions."
	Evaporator Condensate Drain Pan and Gear Motor Drain Pan	Wipe down with a clean cloth and warm water. Slowly pour one cup of sanitizing solution (prepare as outlined in the sanitizing instructions in this manual) into the evaporator condensate drain pan and then slowly pour one cup into the gear motor drain pan. Be careful not to overflow the pans. Repeat with a cup of clean water to rinse.
	Icemaker/Ice Storage Bin Drain	Check to make sure the drain is clear.
	Extruding Head Seal Bolts	Inspect for leakage around seal bolts. Tighten (see torque value below) or replace as necessary. Seal bolts must be replaced once removed because seal material is one-time use only. If new seal bolts do not have preapplied threadlocker, apply Loctite 243 or equivalent threadlocker to seal bolt threads. <ul style="list-style-type: none"> <li>• <i>Torque for F-1001 and Smaller:</i> 11.1 ft-lb/15 N-m</li> </ul> Tighten 2 times. Allow at least 5 sec. in between each tightening.
Yearly	Inlet Water Valve and Drain Valve	Close the water supply line shut-off valve and drain the water system. Clean the inlet water valve screen and clean and inspect the drain valve.
	Water Hoses	Inspect the water hoses and clean/replace if necessary.
	Condenser	Inspect. Clean if necessary by using a brush or vacuum cleaner.
	Icemaker	Inspect for oil spots, loose components, fasteners, and wires.
	Upper Bearing (extruding head)	Check for wear using .02" round stock or pin gauge. Replace both upper bearing and lower bearing if wear exceeds factory recommendations. See the Service Manual for details.
After 3 Years, then Yearly	Upper Bearing (extruding head); Lower Bearing and O-Ring (lower housing); Mechanical Seal; Evaporator Cylinder; Auger	Inspect. Replace both upper bearing and lower bearing if wear exceeds factory recommendations. Replace the mechanical seal if the seal's contact surfaces are worn, cracked, or scratched.

## C. Cleaning and Sanitizing Instructions

The appliance must be cleaned and sanitized at least twice a year. More frequent cleaning and sanitizing may be required in some conditions.

### ⚠ WARNING

- To prevent injury to individuals and damage to the appliance, do not use ammonia type cleaners.
- Carefully follow any instructions provided with the cleaning and sanitizing solutions.
- Always wear liquid-proof gloves and goggles to prevent the cleaning and sanitizing solutions from coming into contact with skin or eyes.
- Do not use ice made from the cleaning and sanitizing solutions. After cleaning and sanitizing, be careful not to leave any solution in the appliance.
- Do not place fingers or any other objects into the ice discharge opening.

### 1. Cleaning Solution

Dilute 4.8 fl. oz. (142 ml) of Hoshizaki "Scale Away" with 0.8 gallons (3 l) of warm water. This is a minimum amount. Make more solution if necessary. **IMPORTANT! For safety and maximum effectiveness, use the solution immediately after dilution.**

### 2. Cleaning Procedure

- 1) Close the water supply line shut-off valve.
- 2) Remove the front panel and top panel. Move the power switch to the "OFF" position, then unplug the appliance from the electrical outlet.
- 3) Remove all ice from the ice storage bin.
- 4) Plug the appliance back in. Move the control switch to the "DRAIN" position, then move the power switch to the "ON" position to drain the appliance.
- 5) After the water has drained, move the power switch to the "OFF" position. Unplug the appliance.
- 6) Lift up the top insulation and unsnap the bin control assembly. Lift the assembly up through the insulation and set it aside. See Fig. 5.
- 7) Remove the top insulation.

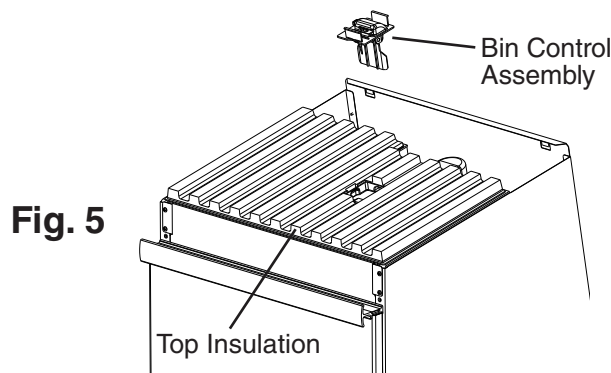

8) Remove spout B, then remove spout A. See Fig. 6.

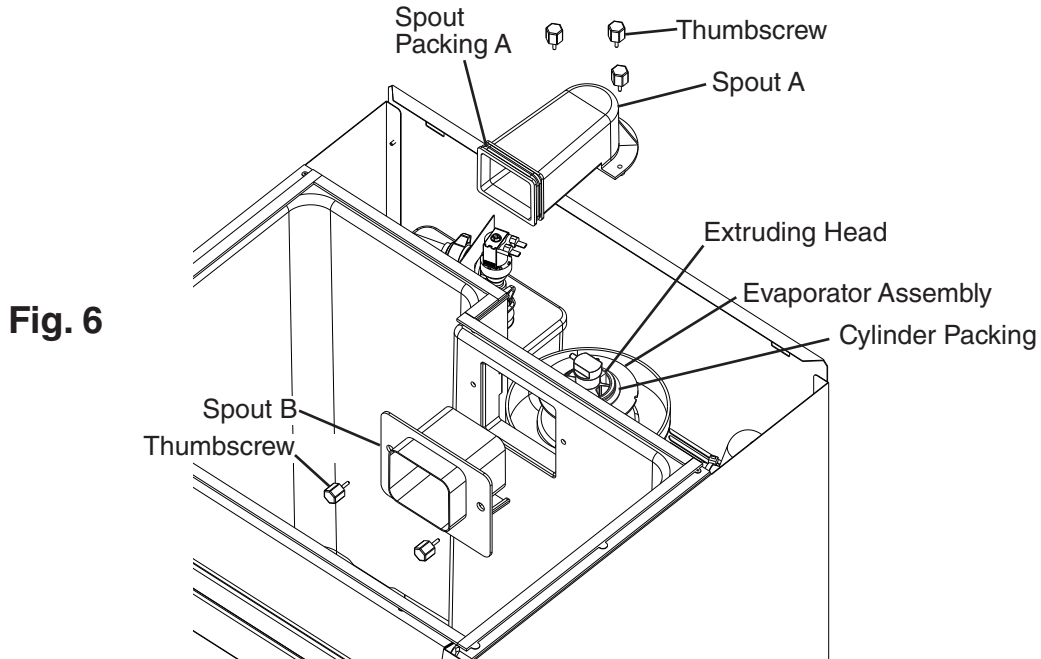

9) Pour the cleaning solution over the extruding head until the evaporator assembly and the reservoir are full and the solution starts to run through the overflow hose on the reservoir.

Note: If there is excess scale on the extruding head, fill the evaporator assembly and reservoir as described above, then use a clamp on the reservoir hose between the reservoir and evaporator assembly to block flow. Pour additional cleaning solution over the extruding head until the evaporator assembly is completely full.

- 10) Allow the appliance to sit for about 10 minutes before operation. If you placed a clamp on the reservoir hose in step 9, remove it before operation.
- 11) In bad or severe water conditions, clean the float switch as described below. Otherwise, continue to step 12.
  - a. Remove the float switch from the reservoir cover.
  - b. Wipe down the float switch with the cleaning solution.
  - c. Rinse the float switch thoroughly with clean water.
  - d. Replace the float switch in its correct position.
- 12) Replace all parts and the top panel.
- 13) Plug the appliance back in. Move the control switch to the "ICE" position, then move the power switch to the "ON" position. Replace the front panel and allow the appliance to make ice using the solution until it stops automatically.
- 14) Remove the front panel.
- 15) Move the power switch to the "OFF" position, then move the control switch to the "DRAIN" position. Move the power switch to the "ON" position to drain the remainder of the solution.
- 16) After the solution has drained, move the control switch to the "ICE" position.
- 17) Replace the front panel.

- 18) Open the water supply line shut-off valve to supply water to the reservoir.
- 19) After the gear motor starts, remove the front panel. Move the power switch to the "OFF" position, then move the control switch to the "DRAIN" position. Move the power switch to the "ON" position to drain the appliance.
- 20) After the water has drained, move the power switch to the "OFF" position. Unplug the appliance.  
 Note: If you do not sanitize the appliance, leave the appliance plugged in with the power switch in the "ON" position and go to step 17 in "5. Sanitizing Procedure - Final."

### 3. Sanitizing Solution

Dilute 2.5 fl. oz. (74 ml or 5 tbs) of a 7.5% sodium hypochlorite solution (chlorine bleach) with 5 gallons (19 l) of warm water. This is a minimum amount. Make more solution if necessary. **IMPORTANT! For safety and maximum effectiveness, use the solution immediately after dilution.**

### 4. Sanitizing Procedure - Initial

- 1) Close the water supply line shut-off valve.
- 2) Remove the top panel. Remove the bin control assembly from the top insulation and set it aside. Remove the top insulation.
- 3) Remove spout B, then remove spout A. Remove spout packing A and the cylinder packing. See Fig. 6.
- 4) Pour the sanitizing solution over the extruding head until the evaporator assembly and the reservoir are full and the solution starts to run through the overflow hose on the reservoir.
- 5) Lift up slightly on the clip securing the bin control switch to the paddle assembly and slide the switch out. See Fig. 7.
- 6) Soak the spouts, packings and paddle assembly in the sanitizing solution for 10 minutes then wipe them down.
- 7) Rinse the parts thoroughly, then replace all parts and the top panel.
- 8) Plug the appliance back in. Move the control switch to the "ICE" position, then move the power switch to the "ON" position. Replace the front panel and allow the appliance to make ice using the solution until it stops automatically.

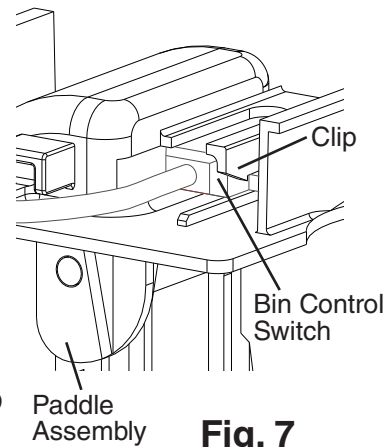

**Fig. 7**

### 5. Sanitizing Procedure - Final

- 1) Dilute 2.5 fl. oz. (74 ml or 5 tbs) of a 7.5% sodium hypochlorite solution (chlorine bleach) with 5 gallons (19 l) of warm water. This is a minimum amount. Make more solution if necessary. **IMPORTANT! For safety and maximum effectiveness, use the solution immediately after dilution.**
- 2) Remove the front panel. Move the power switch to the "OFF" position, then move the control switch to the "DRAIN" position. Move the power switch to the "ON" position to drain the remainder of the solution.

- 3) After the solution has drained, move the power switch to the "OFF" position. Unplug the appliance.
- 4) Remove the top panel.
- 5) Remove the bin control assembly from the top insulation and set it aside. Remove the top insulation.
- 6) Remove spout B, then remove spout A.
- 7) Pour the sanitizing solution over the extruding head until the evaporator assembly and the reservoir are full and the solution starts to run through the overflow hose on the reservoir.
- 8) Allow the appliance to sit for about 10 minutes before operation.
- 9) Replace all parts and the top panel.
- 10) Plug the appliance back in. Move the control switch to the "ICE" position, then move the power switch to the "ON" position. Replace the front panel and allow the appliance to make ice using the solution until it stops automatically.
- 11) Remove the front panel.
- 12) Move the power switch to the "OFF" position, then move the control switch to the "DRAIN" position. Move the power switch to the "ON" position to drain the remainder of the solution.
- 13) After the solution has drained, move the control switch to the "ICE" position.
- 14) Replace the front panel.
- 15) Open the water supply line shut-off valve to supply water to the reservoir.
- 16) After the gear motor starts, remove the front panel. Move the power switch to the "OFF" position, then move the control switch to the "DRAIN" position. Move the power switch to the "ON" position to drain the appliance.
- 17) After the water has drained, move the control switch to the "ICE" position and allow the appliance to run. Replace the front panel.
- 18) After 30 minutes, remove the front panel and move the power switch to the "OFF" position. Unplug the appliance.
- 19) Pour warm water into the ice storage bin to melt all ice, then clean the bin liner with the solution.
- 20) Rinse out any solution from the ice storage bin.
- 21) Plug the appliance back in. Move the power switch to the "ON" position to start the automatic icemaking process.
- 22) Replace the front panel.

---

## V. Preparing the Appliance for Periods of Non-Use

<b>⚠ WARNING</b>
------------------

Only qualified service technicians should service this appliance.
---

<b><i>NOTICE</i></b>
----------------------

- |   |
|---|
| <ul style="list-style-type: none"><li>• During extended periods of non-use, extended absences, or in sub-freezing temperatures, follow the instructions below to reduce the risk of costly water damage.</li><li>• When the appliance is not used for two or three days under normal conditions, it is sufficient to move the power switch to the "OFF" position.</li></ul> |
|---|

- 1) Run the appliance with the water supply line shut-off valve closed. Allow the appliance to make ice until it stops automatically.
- 2) Open the water supply line drain valve and blow the line out using compressed air or carbon dioxide.
- 3) Remove the front panel. Move the power switch to the "OFF" position, then move the control switch to the "DRAIN" position. Move the power switch to the "ON" position to drain the remaining water from the appliance.
- 4) After the water has drained, move the power switch to the "OFF" position. Unplug the appliance.
- 5) Replace the front panel.
- 6) Close the water supply line drain valve.
- 7) Remove all ice from the ice storage bin, then clean and rinse the bin.

## VI. Decommissioning and Disposal



### R-290 Class A3 Flammable Refrigerant Used

#### **⚠ DANGER**

##### **Risk of Fire or Explosion Flammable Refrigerant Used**

- Only qualified service technicians should install and service the appliance.
- Follow handling instructions carefully in compliance with national regulations.
- Dispose of properly in accordance with federal or local regulations.
- Do not puncture refrigerant tubing. Risk of fire or explosion due to puncture of refrigerant tubing; follow handling instructions carefully.
- Be sure to follow the full Decommissioning and Disposal information located in the Service Manual for this model. The Service Manual is available at [www.hoshizakiamerica.com](http://www.hoshizakiamerica.com).

##### **Risque D'Incendie ou D'Explosion. Fluide Frigorigène Inflammable Utilisé**

- Seuls des techniciens de service qualifiés doivent installer et entretenir l'appareil.
- Suivre attentivement les instructions de manutention conformément aux règlements nationaux.
- Mettre au rebut conformément aux conformément aux règlements fédéraux ou locaux.
- Ne pas perforer la conduite de fluide frigorigène. Risque d'incendie ou d'explosion en cas de perforation d'une canalisation de fluide frigorigène; suivez attentivement les instructions de manutention.
- Veiller à respecter l'ensemble des informations relatives à la mise hors service et à la mise au rebut figurant dans le manuel d'entretien de ce modèle. Le manuel d'entretien est disponible à l'adresse suivante: [www.hoshizakiamerica.com](http://www.hoshizakiamerica.com).

**HOSHIZAKI AMERICA, INC.**

618 Hwy. 74 South, Peachtree City, GA 30269 USA (P) 770.487.2331 (F) 770.487.3360 [hoshizakiamerica.com](http://hoshizakiamerica.com) 1A7605-010