



HOSHIZAKI

Service Manual

Self-Contained Flaker

Models

F-330BAK(-C)



hoshizakiamerica.com

Number: 73260
Issued: 8-14-2025

⚠ WARNING

Only qualified service technicians should install and service the appliance. To obtain the name and phone number of your local Hoshizaki Certified Service Representative, visit www.hoshizakiamerica.com. No service should be undertaken until the technician has thoroughly read this Service Manual. Failure to service and maintain the appliance in accordance with this manual will adversely affect safety, performance, component life, and warranty coverage and may result in costly water damage. Proper installation is the responsibility of the installer. Product failure or property damage due to improper installation is not covered under warranty.

Hoshizaki provides this manual primarily to assist qualified service technicians in the service of the appliance.

Should the reader have any questions or concerns which have not been satisfactorily addressed, please call, send an e-mail message, or write to the Hoshizaki Technical Support Department for assistance.

Phone: 1-800-233-1940; (770) 487-2331

E-mail: tech-support@hoshizaki.com

HOSHIZAKI AMERICA, INC.

618 Highway 74 South

Peachtree City, GA 30269

Attn: Hoshizaki Technical Support Department

NOTE: To expedite assistance, all correspondence/communication **MUST** include the following information:

- Model Number _____
- Serial Number _____
- Complete and detailed explanation of the problem.

IMPORTANT

This manual should be read carefully before the appliance is serviced. Read the warnings and guidelines contained in this manual carefully as they provide essential information for the continued safe use, service, and maintenance of the appliance. Retain this manual for any further reference that may be necessary.

CONTENTS

| | |
|---|----|
| Important Safety Information | 4 |
| I. Construction and Water/Refrigeration Circuit Diagram | 9 |
| A. Construction | 9 |
| 1. Icemaker | 9 |
| 2. Icemaking Unit..... | 10 |
| 3. Water/Refrigeration Circuit Diagram | 11 |
| II. Sequence of Operation and Service Diagnosis | 12 |
| A. Sequence of Operation Flow Chart..... | 12 |
| 1. Icemaking and Drain Cycle | 12 |
| 2. Bin Control Shutdown Flow Chart | 13 |
| III. Service Diagnosis, Refrigeration Circuit Service, and Component Service | 14 |
| A. Safety Precautions When Servicing Précautions de sécurité lors de l'entretien..... | 14 |
| 1. English | 14 |
| 2. Français..... | 19 |
| B. Service Diagnosis | 24 |
| 1. Ice Production Check | 25 |
| 2. Diagnostic Procedure..... | 25 |
| 3. Control Board Check | 30 |
| 4. Bin Control Check..... | 34 |
| 5. Float Switch Check and Cleaning..... | 36 |
| 6. Diagnostic Tables..... | 38 |
| 7. Control Board and Control Board Layout..... | 40 |
| 8. LED Lights and Audible Alarm Safeties | 42 |
| 9. Ice Purge Cycle Bypass..... | 43 |
| 10. Controls and Adjustments | 44 |
| 11. Power Switch and Control Switch | 47 |
| C. Refrigeration Circuit Service | 48 |
| D. Component Service Information..... | 52 |
| IV. Maintenance | 62 |
| A. User Maintenance Schedule | 62 |
| B. Service Maintenance Schedule..... | 63 |
| V. Preparing the Appliance for Periods of Non-Use | 64 |
| VI. Decommissioning and Disposal | 65 |
| VII. Technical Information..... | 69 |
| A. Specification & Performance Data Sheets | 69 |
| 1. F-330BAK..... | 69 |
| 2. F-330BAK-C | 70 |
| B. Wiring Diagram..... | 71 |

Important Safety Information

Throughout this manual, notices appear to bring your attention to situations which could result in death, serious injury, damage to the appliance, or damage to property.

| | |
|--|---|
|  | R-290 Class A3 Flammable Refrigerant Used |
| ⚠ DANGER | Indicates a hazardous situation that, if not avoided, will result in death or serious injury. |
| ⚠ WARNING | Indicates a hazardous situation that, if not avoided, could result in death or serious injury. |
| NOTICE | Indicates a situation that, if not avoided, could result in damage to the appliance or property. |
| IMPORTANT | Indicates important information about the use and care of the appliance. |
| ⚠ DANGER | |
| <p><u>Risk of Fire or Explosion</u> <u>Flammable Refrigerant Used</u></p> <ul style="list-style-type: none"> • Qualified service technicians are those having the appropriate technical training and experience necessary to be aware of hazards to which they are exposed in performing a task and of measures necessary to minimize the danger to themselves or other persons. • No service should be undertaken until the technician has thoroughly read this Service Manual. All safety precautions must be followed. • This appliance to be installed in accordance with the Safety Standard for Refrigeration Systems ANSI/ASHRAE 15. • Follow handling instructions carefully in compliance with national regulations. • Do not use mechanical devices or other means to accelerate the defrosting process or to clean, other than those recommended by the manufacturer. • Do not puncture refrigerant tubing. Risk of fire or explosion due to puncture of refrigerant tubing; follow handling instructions carefully. | <ul style="list-style-type: none"> • Servicing shall be done by trained service personnel with certified competence in handling flammable refrigerants to minimize the risk of possible ignition due to incorrect parts or improper service. • Component parts shall be replaced with like components. so as to minimize the risk of possible ignition due to incorrect parts. • Dispose of properly in accordance with federal or local regulations. • Do not pierce or burn. • Be aware that refrigerants may not contain an odor. • Do not damage the refrigeration circuit. • See nameplate for R-290 refrigerant charge: <ul style="list-style-type: none"> • If greater than 114 g (4 oz.), do not install in public corridor or lobby. • If greater than 152 g (5.3 oz.), do not install within 6 m (20 ft) of open flame. • The appliance shall be stored in a room without continuously operating ignition sources (for example: open flames, an operating gas appliance, or an operating electric heater). |

⚠ DANGER continued

- Do not place any potential ignition sources in or near the appliance.
- Keep clear of obstruction all ventilation openings in the appliance enclosure or in the structure for building-in.
- No potential sources of ignition are to be used in the searching for or detection of refrigerant leaks.
- Do not use electrical appliances inside the appliance unless they are of the type recommended by the manufacturer.
- Do not store explosive substances such as aerosol cans with a flammable propellant in this appliance.
- Check that cabling will not be subject to wear, corrosion, excessive pressure, vibration, sharp edges, or any other adverse environmental effects. The check shall also take into account the effects of aging or continual vibration from sources such as compressors or fans.
- Ensure that the area is in the open or that it is adequately ventilated before breaking into the system or conducting any hot work. A degree of ventilation shall continue during the period that the work is carried out. The ventilation should safely disperse any released refrigerant and preferably expel it externally into the atmosphere.

**Risque D'Incendie ou D'Explosion
Fluide Frigorigène Inflammable Utilisé**

- Les techniciens de service qualifiés sont ceux qui possèdent la formation technique et l'expérience nécessaires pour être conscients des dangers auxquels ils sont exposés dans l'accomplissement d'une tâche et des mesures nécessaires pour réduire au minimum le danger pour eux-mêmes ou pour d'autres personnes.
- Aucune opération d'entretien ne doit être entreprise avant que le technicien n'ait lu attentivement ce manuel. Toutes les précautions de sécurité doivent être suivies.
- Cet appareil doit être installé conformément à la norme de sécurité pour les systèmes de réfrigération ANSI/ASHRAE 15.
- Suivez attentivement les instructions de manutention conformément aux règlements nationaux.
- Ne pas utiliser de dispositifs mécaniques ou d'autres moyens pour accélérer le processus de dégivrage ou pour nettoyer, autres que ceux recommandés par le fabricant.
- Ne pas perforer la conduite de fluide frigorigène. Risque d'incendie ou d'explosion en cas de perforation d'une canalisation de fluide frigorigène; suivez attentivement les instructions de manutention.
- L'entretien doit être effectué par du personnel formé et certifié pour la manipulation de réfrigérants inflammables afin de réduire au minimum le risque d'inflammation dû à des pièces incorrectes ou à un entretien inadéquat.
- Les pièces doivent être remplacées par des pièces similaires, de manière à réduire au minimum le risque d'inflammation dû à des pièces incorrectes.

⚠ DANGER continué

- Mettre au rebut conformément aux règlements fédéraux ou locaux.
- Ne pas percer ou brûler.
- Attention, les fluides frigorigènes peuvent ne pas dégager d'odeur.
- Ne pas endommager les composants du circuit de réfrigération.
- Voir plaque signalétique pour la charge de réfrigérant R-290:
 - Si elle est supérieure à 114 g (4 oz.), ne pas l'installer dans un couloir public ou un hall d'entrée.
 - Si elle est supérieure à 152 g (5,3 oz.), ne pas l'installer à moins de 6 m (20 pi) d'une flamme nue.
- L'appareil doit être entreposé dans un local ne contenant pas de sources d'inflammation permanentes (flammes nues, appareil à gaz ou dispositif de chauffage électrique en fonctionnement, par exemple).
- Ne placer aucune source d'inflammation potentielle à l'intérieur ou à proximité de l'appareil.
- Ne pas obstruer les ouvertures de ventilation dans l'enceinte de l'appareil ou dans la structure d'encastrement.
- Aucune source potentielle d'inflammation ne doit être utilisée pour rechercher ou détecter des fuites de réfrigérant.
- Ne pas utiliser d'appareils électriques à l'intérieur de l'appareil, sauf s'ils sont du type recommandé par le fabricant.
- Ne pas entreposer dans cet appareil des substances explosives telles que des bombes aérosols contenant un gaz propulseur inflammable.
- Vérifier que le câblage ne sera pas soumis à l'usure, à la corrosion, à une pression excessive, à des vibrations, à des arêtes vives ou à tout autre effet environnemental négatif. Le contrôle doit également prendre en compte les effets du vieillissement ou des vibrations continues provenant de sources telles que les compresseurs ou les ventilateurs.
- S'assurer que la zone est à l'air libre ou qu'elle est correctement ventilée avant de pénétrer dans le système ou d'effectuer un travail à chaud. Une certaine ventilation doit être maintenue pendant la durée des travaux. La ventilation doit permettre de disperser en toute sécurité tout réfrigérant libéré et, de préférence, de l'expulser dans l'atmosphère.

WARNING

The appliance should be destined only to the use for which it has been expressly conceived. Any other use should be considered improper and therefore dangerous. The manufacturer cannot be held responsible for injury or damage resulting from improper, incorrect, and unreasonable use. Failure to service and maintain the appliance in accordance with this manual will adversely affect safety, performance, component life, and warranty coverage and may result in costly water damage.

To reduce the risk of death, electric shock, serious injury, or fire, follow basic precautions including the following:

- This appliance is not intended for use above 2,000 m (6,561 ft). Installation above 2,000 m (6,561 ft) may adversely affect safety, performance, and component life.
 - Wear appropriate personal protective equipment (PPE) when servicing the appliance.
 - The appliance must be installed in accordance with applicable national, state, and local codes and regulations. Failure to meet these code requirements could result in death, electric shock, serious injury, fire, or damage.
 - The appliance requires an independent power supply of proper capacity. See the nameplate for electrical specifications. Failure to use an independent power supply of proper capacity can result in a tripped breaker, blown fuse, damage to existing wiring, or component failure. This could lead to heat generation or fire.
 - Risk of electric shock. Use extreme caution and exercise safe electrical practices.
 - Risk of electric shock. Control switch in "OFF" position does not de-energize all loads (optional drain pump).
 - Moving parts (e.g., fan blade) can crush and cut. Keep hands clear.
- **THE APPLIANCE MUST BE GROUNDED.** The appliance is equipped with a NEMA 5-15 three-prong grounding plug  to reduce the risk of potential shock hazards. It must be plugged into a properly grounded, independent 3-prong wall outlet. If the outlet is a 2-prong outlet, it is your personal responsibility to have a qualified electrician replace it with a properly grounded, independent 3-prong wall outlet. Do not remove the ground prong from the power cord and do not use an adapter plug. Failure to follow these instructions may result in death, electric shock, or fire.
 - To reduce the risk of electric shock, do not touch the control switch or plug with damp hands.
 - To reduce the risk of electric shock, make sure the control switch is in the "OFF" position before plugging in or unplugging the appliance.
 - Unplug the appliance before servicing.
 - Do not use an appliance with a damaged power cord. The power cord should not be altered, jerked, bundled, weighed down, pinched, or tangled. Such actions could result in electric shock or fire. To unplug the appliance, be sure to pull the plug, not the cord, and do not jerk the cord.
 - Do not use an extension cord.
 - If the supply cord is damaged, it must be replaced by the manufacturer, its service agent, or similarly qualified persons in order to avoid a hazard. Upon replacement, the GREEN ground wire in the power cord must be connected to the designated grounding screw.
 - Do not make any alterations to the appliance. Alterations could result in electric shock, injury, fire, or damage to the appliance.
 - Appliance is heavy. Use care when lifting or positioning. Work in pairs when needed to prevent injury or damage.

⚠ WARNING continued

- The appliance is not intended for use by persons (including children) with reduced physical, sensory, or mental capabilities, or lack of experience and knowledge, unless they have been given supervision or instruction concerning use of the appliance by a person responsible for their safety.
- Do not splash, pour, or spray water directly onto or into the appliance. This might cause short circuit, electric shock, corrosion, or failure.
- Children should be supervised to ensure that they do not play with the appliance.
- Do not climb, stand, or hang on the appliance or drawers or allow children or animals to do so. Do not climb into the appliance or allow children or animals to do so. Death or serious injury could occur or the appliance could be damaged.
- Open and close the door with care. Door opened too quickly or forcefully may cause injury or damage to the appliance or surrounding equipment.
- Be careful not to pinch fingers when opening and closing the door. Be careful when opening and closing the door when children are in the area.
- Do not use combustible spray or place volatile or flammable substances in or near the appliance. They might catch fire.
- Keep the area around the appliance clean. Dirt, dust, or insects in the appliance could cause harm to individuals or damage to the appliance.

NOTICE

- Follow the water supply, drain connection, and maintenance instructions in the instruction manual carefully to reduce the risk of costly water damage.
- In areas where water damage is a concern, install in a contained area with a floor drain. • Install the appliance in a location that stays above freezing. Normal operating ambient temperature must be within 45°F to 100°F (7°C to 38°C).
- To help ensure that the ice storage bin drain remains clear, follow the Ice Storage Bin Drain instructions in the instruction manual once every 3 months or as often as necessary for conditions. If the ice storage bin drain becomes clogged, water could build up in the bin and overflow, leading to costly water damage.
- Do not leave the appliance on during extended periods of non-use, extended absences, or in sub-freezing temperatures. To properly prepare the appliance for these occasions, follow the instructions in "V. Preparing the Appliance for Periods of Non-Use."
- If water collects in the bin and will not drain, turn off the appliance and close the water supply line shut-off valve.
- If water seeps from the base of the appliance, turn off the appliance and close the water supply line shut-off valve. Failure to do so could lead to costly water damage.
- Do not place objects on top of the appliance.
- The ice storage bin is for ice use only. Do not store anything else in the ice storage bin.
- Protect the floor when moving the appliance to prevent damage to the floor.
- Do not allow the appliance to bear any outside weight.

I. Construction and Water/Refrigeration Circuit Diagram

A. Construction

1. Icemaker

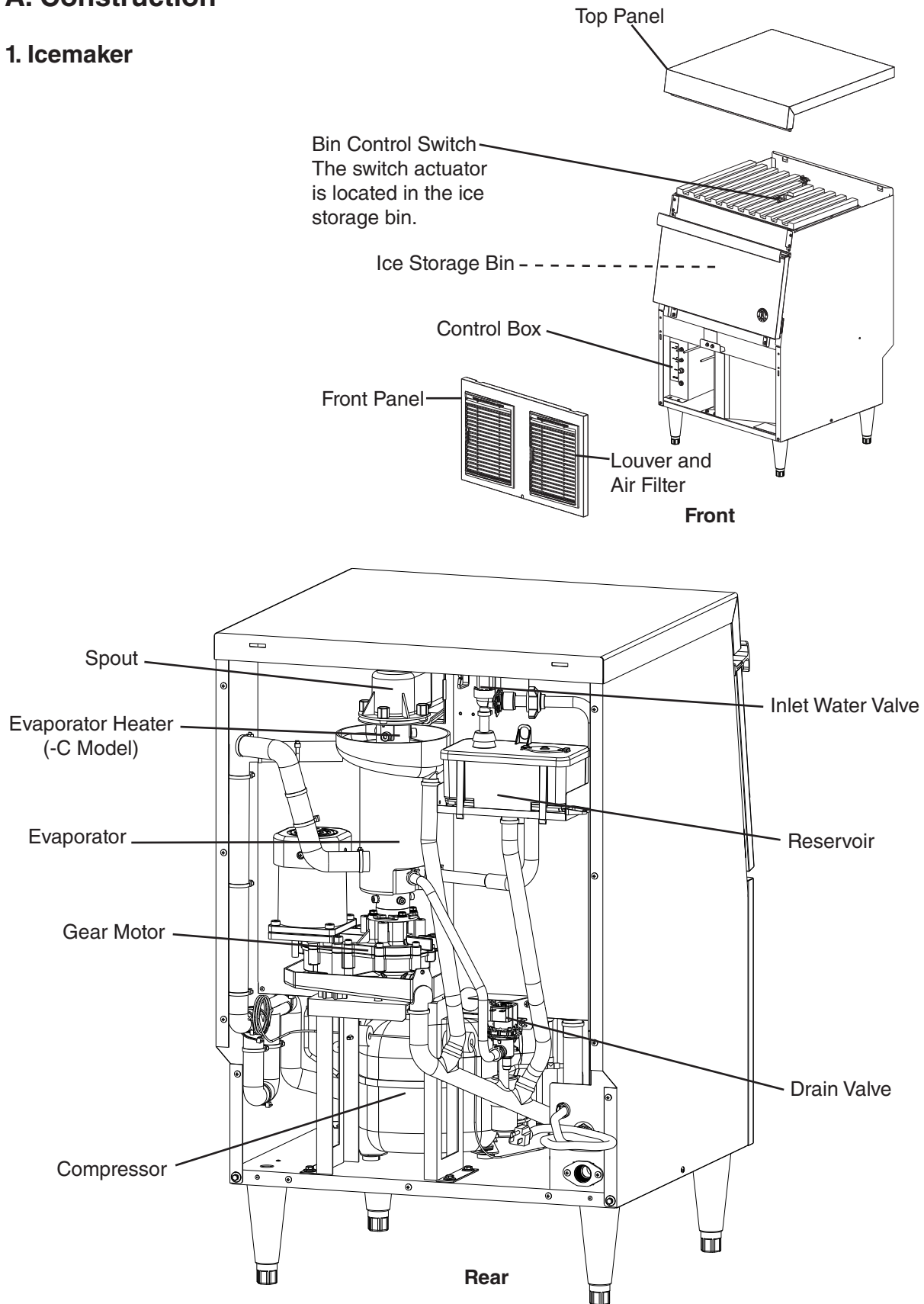

2. Icemaking Unit

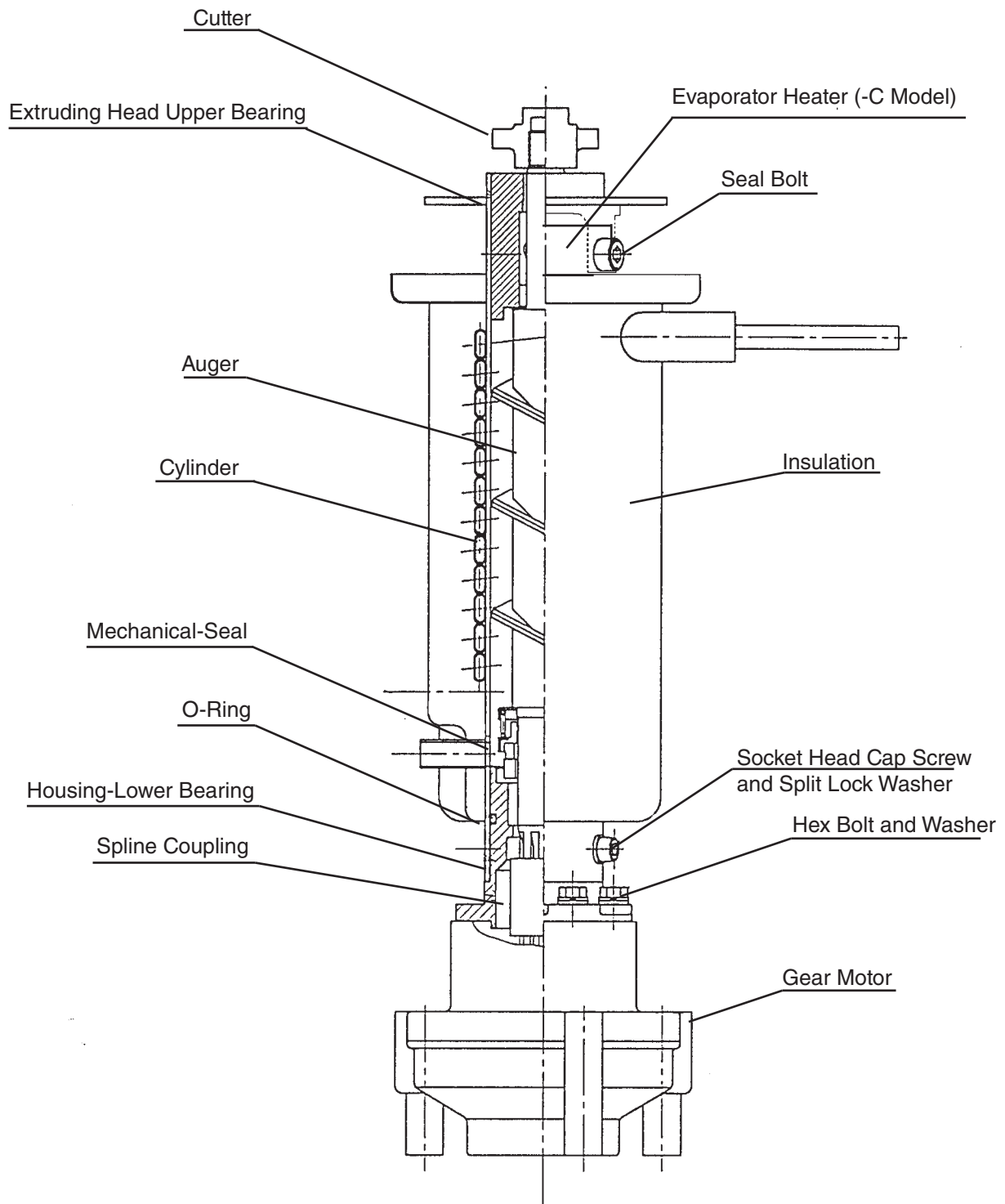

3. Water/Refrigeration Circuit Diagram

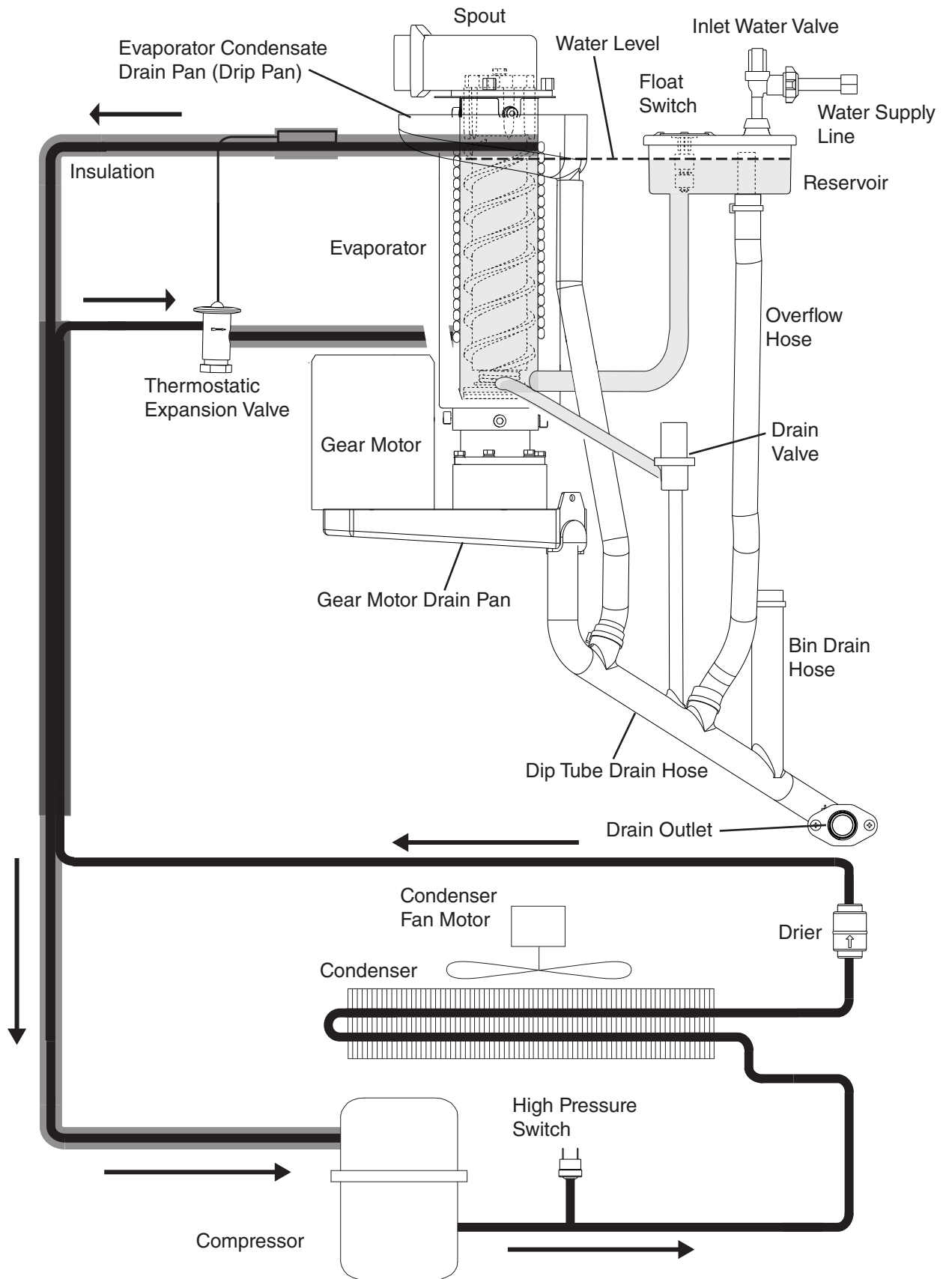

II. Sequence of Operation and Service Diagnosis

A. Sequence of Operation Flow Chart

1. Icemaking and Drain Cycle

F-330BAK(-C) Sequence Flow Chart

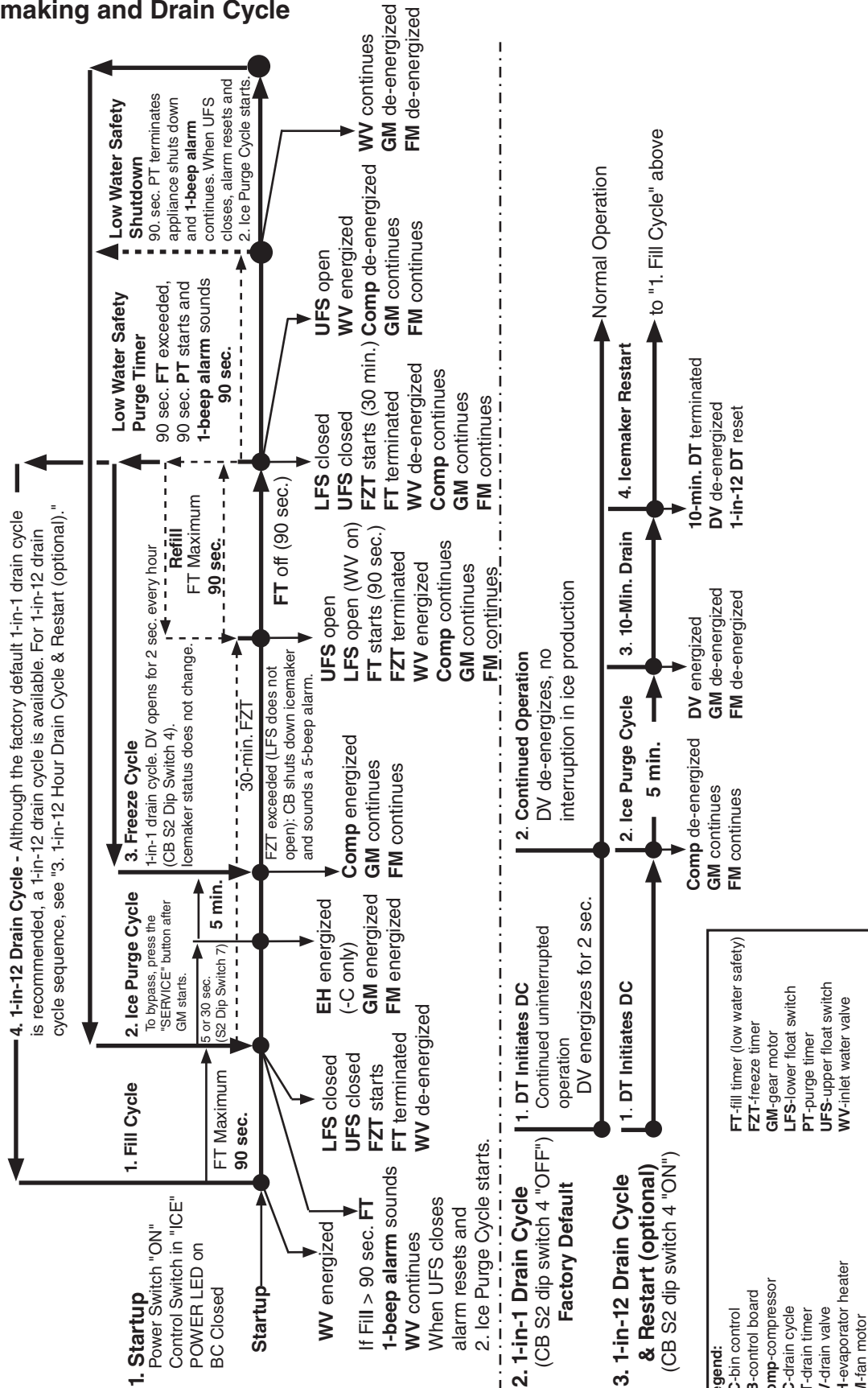

2. Bin Control Shutdown Flow Chart

Control Board Sequence of Operation Flow Chart - Shutdown

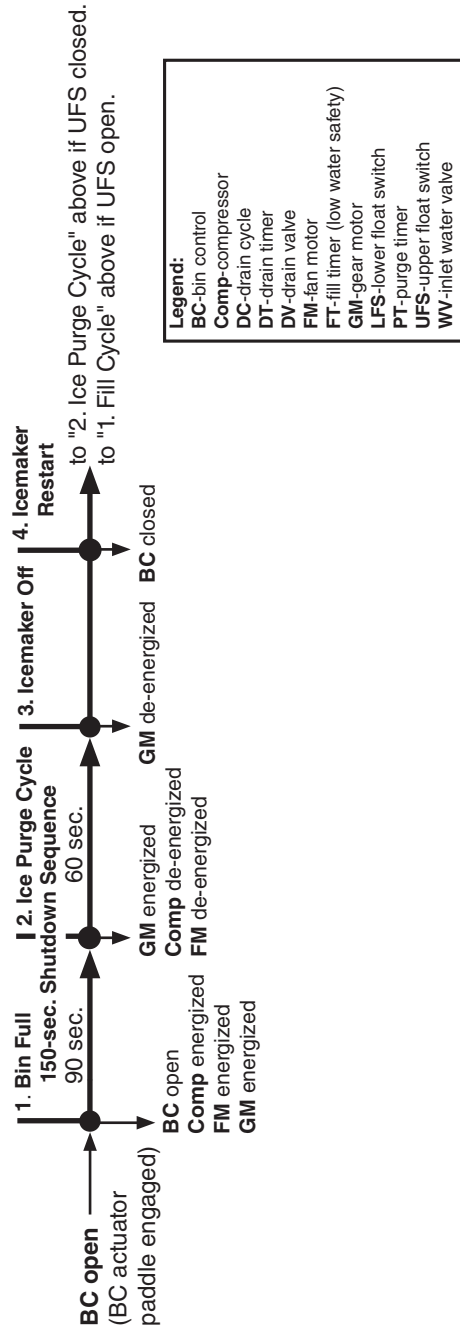

III. Service Diagnosis, Refrigeration Circuit Service, and Component Service

A. Safety Precautions When Servicing | Précautions de sécurité lors de l'entretien

1. English



R-290 Class A3 Flammable Refrigerant Used

⚠ DANGER

Risk of Fire or Explosion. Flammable Refrigerant Used.

- Be sure to follow all Important Safety Information located at the beginning of this manual and in this section.
- The appliance should be diagnosed and repaired only by qualified service personnel to reduce the risk of death, electric shock, serious injury, or fire.
- Servicing shall be done by trained service personnel with certified competence in handling flammable refrigerants to minimize the risk of possible ignition due to incorrect parts or improper service.
- Follow handling instructions carefully in compliance with national regulations.
- Do not use mechanical devices or other means to accelerate the defrosting process or to clean, other than those recommended by the manufacturer.
- Be aware that refrigerants may not contain an odor.
- Do not puncture refrigerant tubing. Risk of fire or explosion due to puncture of refrigerant tubing; follow handling instructions carefully.
- Component parts shall be replaced with like components. So as to minimize the risk of possible ignition due to incorrect parts.
- Do not place any potential ignition sources in or near the appliance.
- Prior to beginning work on systems containing flammable refrigerants, safety checks are necessary to ensure that the risk of ignition is minimized.
- All maintenance staff and others working in the local area shall be instructed on the nature of work being carried out. Work in confined spaces shall be avoided.
- Work shall be undertaken under a controlled procedure so as to minimize the risk of a flammable gas or vapor being present while the work is being performed.
- The area shall be checked with an appropriate refrigerant detector prior to and during work, to ensure the technician is aware of potentially toxic or flammable atmospheres.
- Ensure that the leak detection equipment being used is suitable for use with all applicable refrigerants, i.e., nonsparking, adequately sealed, or intrinsically safe.
NOTE: The use of silicone sealant can inhibit the effectiveness of some types of leak detection equipment.

⚠ DANGER continued

- Under no circumstances shall potential sources of ignition be used in the searching for or detection of refrigerant leaks. A halide torch (or any other detector using a naked flame) shall not be used.
- The following leak detection methods are deemed acceptable for all refrigerant systems:
 - Electronic leak detectors may be used to detect refrigerant leaks but, in the case of flammable refrigerants, the sensitivity might not be adequate, or might need recalibration. (Detection equipment shall be calibrated in a refrigerant-free area.) Ensure that the detector is not a potential source of ignition and is suitable for the refrigerant used. Leak detection equipment shall be set at a percentage of the LFL of the refrigerant and shall be calibrated to the refrigerant employed, and the appropriate percentage of gas (25% maximum) is confirmed.
 - Leak detection fluids are also suitable for use with most refrigerants but the use of detergents containing chlorine shall be avoided as the chlorine can react with the refrigerant and corrode the copper pipe-work.
Note: Examples of leak detection fluids are:
 - bubble method
 - fluorescent method agents
- If any hot work is to be conducted on the refrigerating equipment or any associated parts, appropriate fire extinguishing equipment shall be available on hand. A dry chemical or CO₂ fire extinguisher should be adjacent to the charging area. You must have a Class B chemical fire extinguisher available at all times.
- No person carrying out work in relation to a refrigerating system which involves exposing any pipe work shall use any sources of ignition in such a manner that it may lead to the risk of fire or explosion. All possible ignition sources, including cigarette smoking, should be kept sufficiently far away from the site of installation, repairing, removing, and disposal, during which refrigerant can possibly be released to the surrounding space. Prior to work taking place, the area around the equipment shall be surveyed to make sure that there are no flammable hazards or ignition risks. “No Smoking” signs shall be displayed.
- Ensure that the area is in the open or that it is adequately ventilated before breaking into the system or conducting any hot work. A degree of ventilation shall continue during the period that the work is carried out. The ventilation should safely disperse any released refrigerant and preferably expel it externally into the atmosphere.
- When breaking into the refrigerant circuit to make repairs – or for any other purpose – conventional procedures shall be used. However, for flammable refrigerants it is important that best practice be followed, since flammability is a consideration. The following procedure shall be adhered to:
 - safely remove refrigerant following local and national regulations
 - purge the circuit with inert gas
 - evacuate (optional for A2L)
 - purge with inert gas (optional for A2L)
 - open the circuit by cutting or brazing

⚠ DANGER continued

- If a leak is suspected, all naked flames shall be removed/extinguished.
- If a leakage of refrigerant is found which requires brazing, all of the refrigerant shall be recovered from the system, or isolated (by means of shut off valves) in a part of the system remote from the leak.
- When removing refrigerant from a system, either for servicing or decommissioning, it is recommended good practice that all refrigerants are removed safely.
- When transferring refrigerant into cylinders, ensure that only appropriate refrigerant recovery cylinders are employed. Ensure that the correct number of cylinders for holding the total system charge is available. All cylinders to be used are designated for the recovered refrigerant and labeled for that refrigerant (i.e., special cylinders for the recovery of refrigerant). Cylinders shall be complete with pressure-relief valve and associated shut-off valves in good working order. Empty recovery cylinders are evacuated and, if possible, cooled before recovery occurs.
- The recovery equipment shall be in good working order with a set of instructions concerning the equipment that is at hand and shall be suitable for the recovery of all appropriate refrigerants including, when applicable, flammable refrigerants. In addition, a set of calibrated weighing scales shall be available and in good working order. Hoses shall be complete with leak-free disconnect couplings and in good condition. Before using the recovery machine, check that it is in satisfactory working order, has been properly maintained and that any associated electrical components are sealed to prevent ignition in the event of a refrigerant release. Consult manufacturer if in doubt.
- The recovered refrigerant shall be returned to the refrigerant supplier in the correct recovery cylinder, and the relevant waste transfer note arranged. Do not mix refrigerants in recovery units and especially not in cylinders.
- If compressors or compressor oils are to be removed, ensure that they have been evacuated to an acceptable level to make certain that flammable refrigerant does not remain within the lubricant. The evacuation process shall be carried out prior to returning the compressor to the suppliers. Only electric heating to the compressor body shall be employed to accelerate this process. When oil is drained from a system, it shall be carried out safely.
- In addition to conventional charging procedures, the following requirements shall be followed:
 - Ensure that contamination of different refrigerants does not occur when using charging equipment. Hoses or lines shall be as short as possible to minimize the amount of refrigerant contained in them.
 - Cylinders shall be kept in an appropriate position according to the instructions.
 - Ensure that the refrigerating system is earthed (grounded) prior to charging the system with refrigerant.
 - Label the system when charging is complete (if not already).
 - Extreme care shall be taken not to overfill the refrigerating system.
- Prior to recharging the system, it shall be pressure-tested with the appropriate purging gas. The system shall be leak-tested on completion of charging but prior to commissioning. A follow up leak test shall be carried out prior to leaving the site.

DANGER continued

- Repair and maintenance to electrical components shall include initial safety checks and component inspection procedures. If a fault exists that could compromise safety, then no electrical supply shall be connected to the circuit until it is satisfactorily dealt with. If the fault cannot be corrected immediately but it is necessary to continue operation, an adequate temporary solution shall be used. This shall be reported to the owner of the equipment, so all parties are advised.
- Confirm that capacitors are discharged: this shall be done in a safe manner to avoid possibility of sparking.
- Confirm that no live electrical components and wiring are exposed while charging, recovering, or purging the system.
- Confirm that there is continuity of earth bonding (grounding).
- During repairs to sealed components, all electrical supplies shall be disconnected from the equipment being worked upon prior to any removal of sealed covers, etc. If it is absolutely necessary to have an electrical supply to equipment during servicing, then a permanently operating form of leak detection shall be located at the most critical point to warn of a potentially hazardous situation.
- Where electrical components are being changed, they shall be fit for the purpose and to the correct specification. At all times, Hoshizaki America's maintenance and service guidelines shall be followed. If in doubt, consult Hoshizaki America's Technical Support department for assistance.
- Confirm the actual refrigerant charge is in accordance with the room size within which the refrigerant containing parts are installed.
- Confirm the ventilation machinery and outlets are operating adequately and are not obstructed.
- Confirm marking to the equipment continues to be visible and legible. Markings and signs that are illegible shall be corrected.
- Confirm refrigerating pipe or components are installed in a position where they are unlikely to be exposed to any substance which may corrode refrigerant containing components, unless the components are constructed of materials which are inherently resistant to being corroded or are suitably protected against being so corroded.
- Particular attention shall be paid to the following to ensure that by working on electrical components, the casing is not altered in such a way that the level of protection is affected. This shall include damage to cables, excessive number of connections, terminals not made to original specification, damage to seals, incorrect fitting of glands, etc.
- Ensure that the apparatus (control box/component) is mounted securely.
- Ensure that seals or sealing materials have not degraded to the point that they no longer serve the purpose of preventing the ingress of flammable atmospheres. Replacement parts shall be in accordance with Hoshizaki America's specifications.
- Do not apply any permanent inductive or capacitance loads to the circuit without ensuring that this will not exceed the permissible voltage and current permitted for the equipment in use.

⚠ DANGER continued

- Intrinsically safe components are the only types that can be worked on while live in the presence of a flammable atmosphere. The test apparatus shall be at the correct rating.
- Replace components only with parts specified by Hoshizaki America. Other parts can result in the ignition of refrigerant in the atmosphere from a leak.
- Check that cabling will not be subject to wear, corrosion, excessive pressure, vibration, sharp edges, or any other adverse environmental effects. The check shall also take into account the effects of aging or continual vibration from sources such as compressors or fans.

2. Français



R-290 Classe A3 Réfrigérant Inflammable Utilisé

⚠ DANGER

Risque De Feu Ou D'Explosion. Fluide Frigorigène Inflammable Utilisé.

- Assurez-vous de suivre toutes les informations importantes de sécurité situées au début de ce manuel et dans cette section.
- L'appareil ne doit être diagnostiqué et réparé que par un personnel qualifié afin de prévenir les risques de mort, d'électrocution, de blessures graves ou d'incendie.
- L'entretien doit être effectué par du personnel formé et certifié pour la manipulation de réfrigérants inflammables afin de réduire au minimum le risque d'inflammation dû à des pièces incorrectes ou à un entretien inadéquat.
- Suivez attentivement les instructions de manutention conformément aux règlements nationaux.
- Ne pas utiliser de dispositifs mécaniques ou d'autres moyens pour accélérer le processus de dégivrage ou pour nettoyer, autres que ceux recommandés par le fabricant.
- Attention, les fluides frigorigènes peuvent ne pas dégager d'odeur.
- Ne pas perforer la tubulure contenant le frigorigène. Risque de feu ou d'explosion si la tubulure contenant le frigorigène est perforée; suivre les instructions de manutention avec soin.
- Les pièces doivent être remplacées par des pièces similaires, de manière à réduire au minimum le risque d'inflammation dû à des pièces incorrectes.
- Ne placez aucune source d'inflammation potentielle dans ou près de l'appareil.
- Avant de commencer à travailler sur des systèmes contenant des réfrigérants inflammables, des contrôles de sécurité sont nécessaires pour s'assurer que le risque d'inflammation est minimisé.
- Tout le personnel d'entretien et les autres personnes travaillant dans la zone locale doivent être informés de la nature des travaux effectués. Les travaux dans des espaces confinés doivent être évités.
- Les travaux doivent être entrepris selon une procédure contrôlée afin de minimiser le risque de présence de gaz ou de vapeur inflammable pendant l'exécution des travaux.
- La zone doit être contrôlée à l'aide d'un détecteur de réfrigérant approprié avant et pendant les travaux, afin de s'assurer que le technicien est conscient de l'existence d'atmosphères potentiellement toxiques ou inflammables.
- Assurez-vous que l'équipement de détection des fuites utilisé est adapté à l'utilisation de tous les réfrigérants applicables, c'est-à-dire qu'il ne produit pas d'étincelles, qu'il est correctement scellé ou qu'il est intrinsèquement sûr. REMARQUE: L'utilisation de mastic silicone peut réduire l'efficacité de certains types d'équipements de détection des fuites.
- En aucun cas, des sources potentielles d'inflammation ne doivent être utilisées pour rechercher ou détecter des fuites de réfrigérant. Une lampe haloïde (ou tout autre détecteur utilisant une flamme nue) ne doit pas être utilisée.

DANGER Continué

- Les méthodes de détection de fuite suivantes sont considérées comme acceptables pour tous les systèmes de réfrigération:
 - Des détecteurs de fuites électroniques peuvent être utilisés pour détecter les fuites de réfrigérants, mais, dans le cas de réfrigérants inflammables, la sensibilité pourrait ne pas être adéquate ou nécessiter un réétalonnage. (L'équipement de détection doit être étalonné dans une zone sans réfrigérant.) Assurez-vous que le détecteur n'est pas une source potentielle d'inflammation et qu'il est adapté au réfrigérant utilisé. L'équipement de détection des fuites doit être réglé sur un pourcentage de la LII du réfrigérant et doit être étalonné en fonction du réfrigérant utilisé, et le pourcentage approprié de gaz (25% au maximum) est confirmé.
 - Les liquides de détection des fuites conviennent également à la plupart des réfrigérants, mais l'utilisation de détergents contenant du chlore doit être évitée, car le chlore peut réagir avec le réfrigérant et corroder la tuyauterie en cuivre.
Remarque: Voici quelques exemples de liquides de détection de fuites:
 - méthode des bulles
 - agents de méthode fluorescents
- Si un travail à chaud doit être effectué sur l'équipement réfrigérant ou toute partie associée, un équipement d'extinction d'incendie approprié doit être disponible. Un extincteur à poudre chimique ou à CO₂ devrait être installé à proximité de la zone de chargement. Un extincteur chimique de classe B doit être disponible à tout moment.
- Il est interdit à toute personne effectuant des travaux en rapport avec un système réfrigérant qui impliquent la mise à nu d'une tuyauterie d'utiliser des sources d'inflammation de manière à entraîner un risque d'incendie ou d'explosion. Toutes les sources d'inflammation possibles, y compris la cigarette, doivent être suffisamment éloignées du site d'installation, de réparation, d'enlèvement et d'élimination, au cours desquels du réfrigérant peut éventuellement être libéré dans l'espace environnant. Avant d'entamer les travaux, la zone autour de l'équipement doit être étudiée pour s'assurer qu'il n'y a aucun risque d'inflammabilité ou d'inflammation. Des panneaux « Interdiction de fumer » doivent être affichés.
- Assurez-vous que la zone est à l'air libre ou qu'elle est correctement ventilée avant de pénétrer dans le système ou d'effectuer un travail à chaud. Un certain degré de ventilation doit être maintenu pendant la période où les travaux sont effectués. La ventilation doit permettre de disperser en toute sécurité tout réfrigérant libéré et, de préférence, de l'expulser dans l'atmosphère.

⚠ DANGER Continué

- Pour pénétrer dans le circuit du réfrigérant afin d'effectuer des réparations ou pour toute autre raison, des procédures conventionnelles doivent être utilisées. Toutefois, pour les réfrigérants inflammables, il est important de suivre les meilleures pratiques, car l'inflammabilité est un facteur à prendre en considération. La procédure suivante doit être respectée:
 - éliminer le réfrigérant en toute sécurité conformément aux réglementations locales et nationales
 - purger le circuit avec du gaz inerte
 - évacuer (en option pour A2L)
 - purger avec du gaz inerte (en option pour A2L)
 - ouvrir le circuit par coupure ou brasage
- Si une fuite est suspectée, toutes les flammes nues doivent être enlevées/éteintes.
- Si une fuite de réfrigérant nécessitant un brasage est constatée, tout le réfrigérant doit être récupéré dans le système ou isolé (au moyen de vannes d'arrêt) dans une partie du système éloignée de la fuite.
- Lors de l'élimination du réfrigérant d'un système, que ce soit pour l'entretien ou la mise hors service, il est recommandé de veiller à ce que tous les réfrigérants soient éliminés en toute sécurité.
- Lors du transfert de réfrigérant dans des bouteilles, veillez à ce que seules des bouteilles de récupération de réfrigérant appropriées soient utilisées. Assurez-vous que le nombre de bouteilles nécessaires pour contenir la charge totale du système est disponible. Toutes les bouteilles à utiliser sont désignées pour le réfrigérant récupéré et étiquetées pour ce réfrigérant (c'est-à-dire des bouteilles spéciales pour la récupération du réfrigérant). Les bouteilles doivent être équipées d'une soupape de surpression et de soupapes d'arrêt associées qui sont en bon état de fonctionnement. Les bouteilles de récupération vides sont évacuées et, si possible, refroidies avant la récupération.
- L'équipement de récupération doit être en bon état de fonctionnement, accompagné d'un ensemble d'instructions concernant l'équipement disponible et doit être adapté à la récupération de tous les réfrigérants appropriés, y compris, le cas échéant, les réfrigérants inflammables. En outre, un ensemble de balances étalonnées doit être disponible et en bon état de fonctionnement. Les tuyaux doivent être complets, équipés de raccords de déconnexion sans fuite et en bon état. Avant d'utiliser la machine de récupération, vérifiez qu'elle est en bon état de fonctionnement, qu'elle a été correctement entretenue et que tous les composants électriques associés sont scellés pour éviter toute inflammation en cas de fuite de réfrigérant. Consulter le fabricant en cas de doute.
- Le réfrigérant récupéré doit être renvoyé au fournisseur de réfrigérant dans la bouteille de récupération appropriée et le bon de transfert de déchets correspondant doit être établi. Ne mélangez pas les réfrigérants dans les unités de récupération et surtout pas dans les bouteilles.

⚠ DANGER Continué

- Si les compresseurs ou les huiles de compresseur doivent être retirés, assurez-vous qu'ils ont été évacués à un niveau acceptable afin de s'assurer qu'il ne reste pas de réfrigérant inflammable dans le lubrifiant. Le processus d'évacuation doit être effectué avant que le compresseur ne soit renvoyé aux fournisseurs. Seul le chauffage électrique du boîtier du compresseur doit être utilisé pour accélérer ce processus. Lorsque l'huile est vidangée d'un système, cette opération doit être effectuée en toute sécurité.
- En plus des procédures de charge conventionnelles, les exigences suivantes doivent être respectées:
 - S'assurer qu'aucune contamination de différents réfrigérants ne se produit lors de l'utilisation de l'équipement de charge. Les tuyaux ou conduites doivent être aussi courts que possible afin de minimiser la quantité de réfrigérant qu'ils contiennent.
 - Les bouteilles doivent être maintenues dans une position appropriée conformément aux instructions.
 - S'assurer que le système de réfrigération soit mis à la terre avant de charger le système avec du réfrigérant.
 - Étiqueter le système lorsque la charge est terminée (si cela n'a pas déjà été fait).
 - Il faut veiller à ne pas trop remplir le système de réfrigération.
- Avant de recharger le système, celui-ci doit être testé sous pression avec le gaz de purge approprié. Le système doit être soumis à un essai de fuite à la fin de la charge, mais avant la mise en service. Un test de contrôle de fuite doit être effectué avant de quitter le site.
- La réparation et l'entretien des composants électriques incluent les contrôles de sécurité initiaux et les procédures d'inspection des composants. En cas de défaut susceptible de compromettre la sécurité, aucune alimentation électrique ne doit être connectée au circuit tant que le problème n'a pas été résolu de manière satisfaisante. Si le défaut ne peut être corrigé immédiatement mais qu'il est nécessaire de poursuivre l'exploitation, une solution temporaire adéquate doit être utilisée. Cela doit être signalé au propriétaire de l'équipement, afin que toutes les parties soient informées.
- S'assurer que les condensateurs sont déchargés: cette opération doit être effectuée en toute sécurité afin d'éviter tout risque d'étincelle.
- S'assurer qu'aucun composant ou câblage électrique sous tension n'est exposé lors de la charge, de la récupération ou de la purge du système.
- S'assurer de la continuité de la mise à la terre.
- Lors des réparations de composants scellés, toutes les alimentations électriques doivent être déconnectées de l'équipement sur lequel on travaille avant tout retrait des couvercles scellés, etc. Si l'alimentation électrique de l'équipement est absolument nécessaire pendant l'entretien, un dispositif de détection des fuites fonctionnant en permanence doit être placé au point le plus critique afin de signaler en cas de situation potentiellement dangereuse.
- Lorsque des composants électriques sont remplacés, ils doivent être adaptés à l'usage prévu et répondre aux spécifications correctes. Les directives de maintenance et d'entretien de Hoshizaki America doivent être respectées à tout moment. En cas de doute, consulter le service d'assistance technique de Hoshizaki America pour obtenir de l'aide.

⚠ DANGER Continué

- S'assurer que la charge réelle de réfrigérant est conforme à la taille de la pièce dans laquelle les pièces contenant du réfrigérant sont installées.
- S'assurer que les dispositifs et les sorties de ventilation fonctionnent correctement et ne sont pas obstrués.
- S'assurer que le marquage de l'équipement est toujours visible et lisible. Les indications et les panneaux illisibles doivent être corrigés.
- S'assurer que les tuyaux ou les composants de réfrigération sont installés dans un endroit où ils ne risquent pas d'être exposés à une substance susceptible de corroder les composants contenant du réfrigérant, à moins que les composants ne soient construits avec des matériaux intrinsèquement résistants à la corrosion ou qu'ils ne soient protégés de manière appropriée contre la corrosion.
- Une attention particulière doit être accordée aux points suivants afin de s'assurer qu'en travaillant sur les composants électriques, le boîtier n'est pas altéré de manière à ce que le niveau de protection soit affecté. Il s'agit notamment des dommages causés aux câbles, du nombre excessif de connexions, des terminaux non conformes aux spécifications d'origine, des dommages causés aux joints et du montage incorrect des presse-étoupes, etc.
- S'assurer que l'appareil (boîtier de commande/composant) est solidement fixé.
- S'assurer que les joints ou les matériaux d'étanchéité ne sont pas dégradés au point de ne plus pouvoir empêcher la pénétration d'atmosphères inflammables. Les pièces de rechange doivent être conformes aux spécifications de Hoshizaki America.
- N'appliquez aucune charge inductive ou capacitive permanente au circuit sans vous assurer que celle-ci ne dépassera pas la tension et le courant autorisés pour l'équipement utilisé.
- Les composants à sécurité intrinsèque sont les seuls types de composants sur lesquels il est possible de travailler sous tension en présence d'une atmosphère inflammable. L'appareil d'essai doit être adapté à la puissance requise.
- Ne remplacer les composants que par des pièces spécifiées par Hoshizaki America. D'autres pièces peuvent entraîner l'inflammation du réfrigérant dans l'atmosphère à la suite d'une fuite.
- Vérifier que le câblage ne sera pas soumis à l'usure, à la corrosion, à une pression excessive, à des vibrations, à des arêtes vives ou à tout autre effet environnemental négatif. Le contrôle doit également prendre en compte les effets du vieillissement ou des vibrations continues provenant de sources telles que les compresseurs ou les ventilateurs.

B. Service Diagnosis



R-290 Class A3 Flammable Refrigerant Used

⚠ DANGER

Risk of Fire or Explosion. Flammable Refrigerant Used.

- Be sure to follow all Important Safety Information located at the beginning of this manual and at the beginning of section "III.A. Safety Precautions When Servicing."
- Servicing shall be done by trained service personnel with certified competence in handling flammable refrigerants to minimize the risk of possible ignition due to incorrect parts or improper service.

Risque De Feu Ou D'Explosion. Fluide Frigorigène Inflammable Utilisé.

- Assurez-vous de suivre toutes les informations importantes de sécurité qui se trouvent au début du présent manuel et au début de la section «III.A. Précautions de sécurité lors de l'entretien.»
- L'entretien doit être effectué par du personnel formé et certifié pour la manipulation de réfrigérants inflammables afin de réduire au minimum le risque d'inflammation dû à des pièces incorrectes ou à un entretien inadéquat.

⚠ WARNING

- Risk of electric shock. Use extreme caution and exercise safe electrical practices.
- Risk of electric shock. Control switch in "OFF" position does not de-energize all loads (optional drain pump).
- Move the control switch to the "OFF" position, then unplug the appliance from the electrical outlet before servicing.
- Moving parts (e.g., fan blade) can crush and cut. Keep hands clear.
- **CHOKING HAZARD:** Ensure all components, fasteners, and thumbscrews are securely in place after the appliance is serviced. Make sure that none have fallen into the ice storage bin.
- Make sure all food zones in the appliance are clean after service.

1. Ice Production Check

To check production, prepare a bucket or pan to catch the ice and a set of scales to weigh the ice. After the icemaker has operated for 10 to 20 minutes, catch the ice production for 10 minutes. Weigh the ice to establish the batch weight. Multiply the batch weight by 144 for the total production in 24 hours. When confirming production or diagnosing low production, reference production information to the performance data charts found in "VII.A. Specification and Performance Data Sheets."

2. Diagnostic Procedure

This diagnostic procedure is a sequence check that allows you to diagnose the electrical system and components. Before proceeding, check for correct installation, proper voltage per appliance nameplate, and adequate water pressure (10 PSIG to 113 PSIG).

Note: • When checking high voltage (115VAC), always choose a neutral (W) wire to establish a good neutral connection.

- When checking low voltage (24VAC), always choose a neutral (LBU) wire to establish a good neutral connection.
 - When checking control board DC voltage (5VDC), always place the red positive test lead from the multimeter to CB K5 pin closest to CB K4 connector. See "III.B.3. Control Board Check."
 - To speed up the diagnostic process, the 5-min. ice purge cycle may be bypassed by pressing the "SERVICE" button on the control board after the gear motor starts. **WARNING! Risk of electric shock. Care should be taken not to touch live terminals.**
 - If the icemaker is in alarm, see "III.B.8. LED Lights and Audible Alarm Safeties."
 - FM and EH (-C model) energize when "GM" LED turns on.
 - CB monitors the following switches with 5VDC during the icemaking process: Control Switch (CS), High-Pressure Switch (HPS), Float Switch (FS), Compressor Control Relay/Gear Motor Protect Relay (CCR/GMPR), and Bin Control (mechanical stand-alone). When 5VDC is present across any of these switches, the switch is open.
- 1) Remove the front panel, then move the power switch to the "OFF" position. Move the control switch to the "DRAIN" position, then move the power switch back to the "ON" position. Replace the front panel in its correct position.
 - 2) Allow the water system to drain for 5 min.
 - 3) Remove the front panel. Move the power switch to the "OFF" position, then turn off the power supply.
 - 4) Remove the control box cover and access CB.
 - 5) Check the CB S2 dip switch settings, see "III.B.10. Controls and Adjustments" to assure that they are in the correct positions. For proper operation of BC (mechanical stand-alone), confirm that S2 dip switch 7 is in the "OFF" position.

6) **Startup–CB "POWER" LED is on.** Turn on the power supply, then move the power switch to the "ON" position. Make sure the control switch is in the "ICE" position. CB "POWER" LED turns on.

Diagnosis CB "POWER" LED: Check that CB "POWER" LED is on. If not, check for 115VAC at the control transformer black (BK) wire to neutral (W). If 115VAC is not present, check the power switch, power supply cord, and breaker. If 115VAC is present, check the control transformer continuity. Replace as needed. Next, check for 24VAC at the control transformer red (R) wire to neutral (LBU). If 24VAC is not present, check the control transformer continuity. Replace as needed. If 24VAC is present, check the 24VAC 3A fuse. If the fuse is good, check for 24VAC at CB K8 #1 (W/R) to CB K8 #2 (LBU). If 24VAC is present and "POWER" LED is off, replace CB.

Diagnosis BC: Check that the actuator paddle is properly positioned. Check continuity across the BC. If open, replace the BC. Next, check VDC at CB K8 #3 (GY) to CB K8 #4 (GY). When the BC is closed 0VDC is read. Move the actuator paddle to open. When open, 5VDC is present between CB K8 #3 (GY) and CB K8 #4 (GY). If 5VDC is not present when the BC is open, replace CB. Return actuator to its normal position.

7) **Fill Cycle – "WTRIN" LED is on.** Reservoir is empty and LFS and UFS are open. 90-sec. FT starts. WV energizes and fill cycle starts. LFS closes. Nothing occurs at this time. Reservoir continues to fill until UFS closes. When UFS closes, WV de-energizes, 90-sec. FT is terminated, and CB "WTRIN" LED turns off. 30-min. FZT and 5-sec. GM delay timer start. If UFS remains open longer than 90 sec. after LFS opens, FT exceeded and CB sounds a 1-beep alarm. WV remains energized until UFS closes. Alarm resets automatically when UFS closes.

Diagnosis: If reservoir is empty and "WTRIN" LED is off, confirm LFS status. See "III.B.5. Float Switch Check and Cleaning." If LFS is open and "WTRIN" LED is off, replace CB. If "WTRIN" LED is on, check that the reservoir fills. If not, check water supply line shut-off valve, water filters, and WV screen. If "WTRIN" LED is on and WV is off, check CB K2 #8 (O) to a neutral (LBU) for 24VAC. If 24VAC is not present, check CB K2 #9 (W/R) to a neutral (LBU) for 24VAC. If 24VAC is present on CB K2 #9 (W/R) and not on CB K2 #8 (O), replace CB. If 24VAC is present on CB K2 #8 (O), check continuity through WV solenoid. If open, replace WV. If WV is energized and refill exceeds FT with no water in the reservoir, check for DV leaking. If reservoir is full and overflowing check for open UFS. See "III.B.5. Float Switch Check and Cleaning." If UFS is closed, check that WV de-energizes. If not, check CB K2 #8 (O) to a neutral (LBU) for 24VAC. If 24VAC is present, replace CB. If WV de-energizes and water continues to fill the reservoir, replace WV.

8) **Ice Purge Cycle – "GM" LED is on.** 5-sec. GM delay timer terminates. GM, CCR, FM, and EH (-C model) energize. Once CCR energizes, 5VDC circuit closes through CCR terminal #3 (W/O) and terminal #5 (W/O) and CB K9 #5 (W/O) and K9 #6 (W/O). After 5VDC circuit closes, 5-min. ice purge timer starts. To bypass the 5-min. Ice Purge Cycle, press the "SERVICE" button on CB after the "GM" LED turns on. **WARNING! Risk of electric shock. Care should be taken not to touch live terminals.**

Diagnosis: If "GM" LED is off, check that UFS closes and WV de-energizes. If UFS is closed, 30 sec. has passed, and "GM" LED remains off, replace CB. If "GM" LED is on and GM is off, check CB K1 #2 (BK) to a neutral (W) for 115VAC. If 115VAC is not present, check 115VAC power supply. If 115VAC is present, check CB K1 #3 (P) to a neutral (W). If 115VAC is present on CB K1 #2 (BK) and not on CB K1 #3 (P), replace CB. If 115VAC is present on CB K1 #3 (P), check GM fuse, GM internal protector, GM windings and capacitor, and GM coupling between auger and GM. When GM energizes, CCR energizes starting 5-min. ice purge timer. If FM does not start, check FM capacitor, FM windings, and FM bearings.

9) **Freeze Cycle – "COMP" and "GM" LEDs are on.** The 5-min. ice purge timer terminates. GM, EH (-C model), CCR, and FM continue. Comp energizes. Ice production starts 4 to 6 min. after Comp energizes depending on ambient and water conditions. As ice is produced, the water level in the reservoir drops. UFS opens. Nothing happens at this time. When LFS opens, WV energizes and refill cycle begins, FZT terminates, and FT starts.

FZT: 30-Min. Freeze Safety Timer – FZT starts when UFS closes and terminates when LFS opens. If LFS does not open within 30 min. of UFS closing, CB shuts down the icemaker and sounds a 5-beep alarm. See "III.B.8. LED Lights and Audible Alarm Safeties." To reset, turn the power supply off and on again. See "III.B.6. Diagnostic Tables" for troubleshooting details.

Icemaker Diagnosis (CCR): 5-min. ice purge timer terminates, CB "COMP" LED is on and COMP energizes. If not, check for 5VDC between CB K7:1 red connector (open) pin 1 (closest to CB K8:2 white connector) and CB K9 connector #5 (W/O). If 5VDC is not present, replace CB. If 5VDC is present, check for 5VDC between CB K7:1 red connector (open) pin 1, (closest to CB K8:2 white connector) and CB K9 connector #6 (W/O). If 5VDC is present and CB "Comp" LED is off (CR or COMP not energized), replace CB. If 5VDC is not present, check for 115VAC between CCR terminal #7 (O) to CCR terminal #8 (W) for 115VAC. If 115VAC is not present (GM not energized), see step 8 above. If 115VAC is present and CCR contacts are open (5VDC present between terminals #3 (W/O) and #5 (W/O)), check CCR solenoid voltage and solenoid continuity. Replace CCR if necessary.

Icemaker Diagnosis (COMP): If "COMP" LED is on and COMP is not energized, check CB X1 relay BK wire to a neutral (W) and CB X1 relay V wire to a neutral (W) for 115VAC. If 115VAC is present on CB X1 BK wire and not on CB X1 V wire, replace CB. If 115VAC is present on CB X1 V wire and COMP is not energized, check for 115VAC at CB X1 Comp relay. Check Comp internal overload (motor protector), start relay, and capacitors.

10) **Refill Cycle – "GM", "COMP", and "WTRIN" LEDs are on.**

LFS opens. WV energizes and 90-sec. FT starts. Comp, GM, CCR, and FM continue. LFS closes. Nothing occurs at this time. Reservoir continues to fill until UFS closes. When UFS closes, WV de-energizes, 90-sec. FT terminates, and 30-min. FZT starts. If UFS remains open longer than 90 sec. after LFS opens, FT exceeded and CB sounds a 1-beep alarm. WV remains energized until UFS closes. Alarm resets automatically when UFS closes.

Diagnosis – Confirm that the water level has dropped and the UFS and LFS are open. See "III.B.5. Float Switch Check and Cleaning." Check that "WTRIN" LED is on. If LFS is open and "WTRIN" LED is off, replace CB. If "WTRIN" LED is on, check that the reservoir fills. If not, check water supply line shut-off valve, water filters, and WV screen. If "WTRIN" LED is on and WV is off, check CB K2 #8 (O) to a neutral (LBU) for 24VAC. If 24VAC is not present, check CB K2 #9 (W/R) to a neutral (LBU) for 24VAC. If 24VAC is present on CB K2 #9 (W/R) and not on CB K2 #8 (O), replace CB. If 24VAC is present on CB K2 #8 (O), check continuity through WV solenoid. If open, replace WV. If WV is energized and refill exceeds FT with no water in the reservoir, check for DV leaking. If reservoir is full and overflowing check for open UFS. See "III.B.5. Float Switch Check and Cleaning." If UFS is closed, check that WV de-energizes. If not, check CB K2 #8 (O) to a neutral (LBU) for 24VAC. If 24VAC is present, replace CB. If WV de-energizes and water continues to fill the reservoir, replace WV.

Note: Each time UFS closes, 30-min. freeze timer starts. The 30-min. freeze timer resets when UFS closes again. If UFS does not close again within 30 min., CB shuts down the unit and sounds a 5-beep alarm every 5 sec. See "III.B.8. LED Lights and Audible Alarm Safeties."

FT: 90-Sec. Low Water Safety Timer – When LFS opens, 90-sec. low water safety timer starts. If UFS does not close within 90 sec. after LFS opens (FT exceeded), CB sounds a 1-beep alarm and a 90-sec. shutdown cycle starts. See "III.B.8. LED Lights and Audible Alarm Safeties." Comp de-energizes. GM, CCR, and EH (-C model) continue. 90-sec. purge timer terminates, GM, EH (-C model), and CCR de-energize. WV and 1-beep alarm continue until UFS closes.

11) **Drain Cycle**

- a) **1-in-1 Drain Cycle:** DV energizes once every hour when the 1-in-1 drain cycle is activated (S2 dip switch 4 in the "OFF" position (factory default position)). GM, FM, Comp continue. DV energizes for 2 sec. every hour. This setting is recommended for optimum icemaker performance. The 1-in-1 drain cycle allows any sediment to drain from the evaporator without interrupting the icemaking process.
- b) **1-in-12 Drain Cycle (optional):** DV energizes once every 12 hours when the 1-in-12 drain cycle is activated (S2 dip switch 4 in the on position (optional)). 12-hour drain cycle timer terminates, Comp de-energizes. GM, and FM continue. The 5-min. ice purge timer starts. When the 5-min. ice purge timer terminates, GM and FM de-energize. 10-min. DT starts, DV energizes. After 10-min. DT terminates, DV de-energizes icemaking process restarts and 12-hour drain cycle timer starts.

- c) **Manual Drain:** Manual drain is used when servicing evaporator components and cleaning and sanitizing the unit. When the unit is making ice and the control switch is moved to the "DRAIN" position, there is a 3-sec. delay, then Comp de-energizes and the 5-min. ice purge timer begins. When the 5-min. ice purge timer terminates, GM and FM de-energize. DV energizes to drain the evaporator and reservoir. To avoid the 5-min. shutdown delay, turn off the power supply, then move the control switch to the "DRAIN" position. Turn on the power supply. DV energizes to drain the evaporator and reservoir. DV de-energizes when the control switch is moved to the "ICE" position.

12) Shutdown

- a) Bin fills with ice activating BC proximity switch. CB starts 90-sec. Comp shutdown timer. Once 90-sec. Comp shutdown timer terminates, Comp and FM de-energize and 60-sec. GM shutdown timer starts. Once 60-sec. GM shutdown timer terminates, GM de-energizes and icemaker is off.

Shutdown Diagnosis: Check that BC actuator paddle is activated and not sticking. Check BC proximity switch continuity. When BC actuator paddle is down (icemaking), BC proximity switch is closed. When BC actuator paddle is up BC proximity switch is open. If not, replace BC proximity switch. If BC proximity switch is open and Comp, FM, and GM do not de-energize, replace CB. See "III.B.3. Control Board Check."

Note: Dip Switch 9 allows for management between fast shutdown and slow shutdown. Default setting for Dip Switch 9 is "OFF" position (slow shutdown). Dip switch 9 can be moved to the "ON" position for fast-timing (shutdown within 6 to 10 sec.).

Legend: **BC**—bin control; **CB**—control board; **CCR**—compressor control relay; **Comp**—compressor; **DV**—drain valve; **EH**—evaporator heater (-C model); **FM**—fan motor; **FT**—fill timer; **FZT**—freeze safety timer; **GM**—gear motor; **GMR**—gear motor relay; **LFS**—lower float switch; **UFS**—upper float switch; **WV**—inlet water valve

3. Control Board Check

Before replacing a control board that does not show a visible defect and that you suspect is bad, always conduct the following check procedure. This procedure will help you verify your diagnosis.

- 1) Check CB S2 dip switch settings to assure that they are in the factory default position. For factory default settings, see "III.B.10. Controls and Adjustments."

Note: S2 dip switch 7 determines bin control application:

BC: S2 dip switch 7 must be in the "OFF" position on this model.

WARNING! Do not place S2 dip switch 7 in the on position on this model. This could lead to no ice operation, control board alarms, or ice overflow.

- 2) Move the power switch to the "ON" position and move the control switch to the "ICE" position. The "POWER" LED turns on.

Diagnosis "POWER" LED: Check that the CB "POWER" LED is on. If not, check for proper supply voltage (115VAC) input to the control transformer (power switch, power supply cord, breaker, and fuse). Next, check for proper low-voltage (24VAC) output from the control transformer and that the 3A fuse is good. Check for 24VAC at CB K8 #1 (W/R) to CB K8 #2 (LBU). If 24VAC is present and the "POWER" LED is off, replace CB.

- 3) **5VDC Output Checks:**

CB K9 Connector: Control Switch (CB K9 #1 and #2) (open contacts for icemaking, closed contacts for drain), High-Pressure Switch (CB K9 #3 and #4), Compressor Control Relay (K9 #5 and #6).

CB K8 Connector: Bin Control (K8 #3 and #4) and Float Switch (K8 #5 (common), #6 (lower), and #7 (upper)).

When checking 5VDC control voltage, always place the red positive test lead from the multimeter to the CB K7:1 red connector (open) pin 1, (closest to CB K8:2 white connector). See Fig. 1. Then place the black negative test lead from the multimeter to the corresponding pin to complete the 5VDC check.

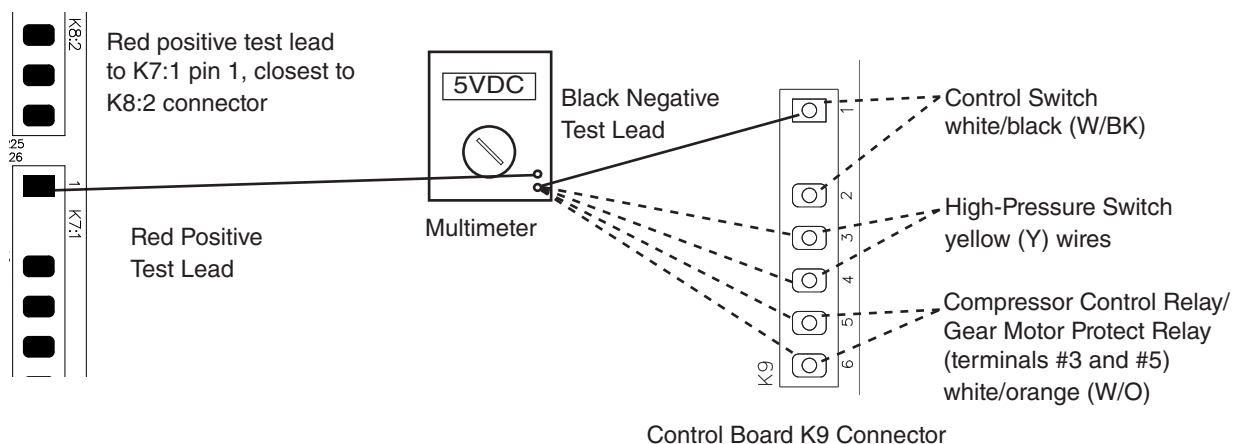

Fig. 1

- a) **Control Switch** – CB K9 #1 (W/BK) and CB K9 #2 (W/BK): 5VDC is present between CB K7:1 red connector (open) pin 1, (closest to CB K8:2 white connector) and CB K9 #1 (W/BK) at all times. If 5VDC is not present, replace CB. When the control switch is in the "ICE" position, the control switch contacts are open. 0VDC is present between CB K7:1 red connector (open) pin 1, (closest to CB K8:2 white connector) and CB K9 #2 (W/BK). When in the "ICE" position, 5VDC is present between CB K9 #1 (W/BK) to CB K9 #2 (W/BK). When the control switch is in the "DRAIN" position, the control switch contacts are closed. 5VDC is present between CB K7:1 red connector (open) pin 1, (closest to CB K8:2 white connector), to CB K9 #1 (W/BK) or #2 (W/BK). If 5VDC is not present, replace CB. 0VDC is present from CB K9 #1 (W/BK) to CB K9 #2 (W/BK).
- b) **High-Pressure Switch** – CB K9 #3 (Y) and CB K9 #4 (Y): 5VDC is present between CB K7:1 red connector (open) pin 1, (closest to CB K8:2 white connector) and CB K9 #3 (Y) at all times. When the high-pressure switch is closed, 5VDC is present between CB K7:1 red connector (open) pin 1, (closest to CB K8:2 white connector) to CB K9 #3 (Y) and CB K9 #4 (Y). If 5VDC is not present, replace CB. When the high-pressure switch is closed, 0VDC is present at CB K9 #3 (Y) to CB K9 #4 (Y). When the high-pressure switch is open, 5VDC is present at CB K9 #3 (Y) to CB K9 #4 (Y). If the high-pressure switch is open and CB is not in alarm, replace CB. If 5VDC is present at CB K9 #3 (Y) and not at CB K9 #4 (Y), the high-pressure switch is open and CB sounds a 3-beep alarm. Check continuity across the high-pressure switch (CB K9 #3 (Y) and CB K9 #4 (Y)).
- c) **Compressor Control Relay (CCR)** – CB K9 #5 (W/O) and CB K9 #6 (W/O): 5VDC is present from CB K7:1 red connector (open) pin 1, (closest to CB K8:2 white connector) to CB K9 #5 (W/O) at all times. If 5VDC is not present, replace CB. When CCR terminals #3 (W/O) and #4 (W/O) are open (CCR de-energized), 5VDC is present between CB K9 #5 (W/O) and CB K9 #6 (W/O). When CCR terminals #3 (W/O) and #4 (W/O) are closed (CCR energized), 5VDC is present between CB K9 #5 (W/O) and CB K9 #6 (W/O). When CCR terminals #3 (W/O) & #5 (W/O) are open CB may be in an 8-beep alarm. See "III.B.8. LED Lights and Audible Alarm Safeties."
- d) **Bin Control** – CB K8 #3 (GY) and CB K8 #4 (GY): 5VDC is present from CB K7:1 red connector (open) pin 1, (closest to CB K8:2 white connector) to CB K8 #3 (GY) at all times. If 5VDC is not present, replace CB. When BC is closed (calling for ice), 5VDC is present from CB K7:1 red connector (open) pin 1, (closest to CB K8:2 white connector), to CB K8 #3 (GY) and CB K8 #4 (GY). If 5VDC is not present to either CB K8 #3 (GY) or CB K8 #4 (GY), replace CB. If 5VDC is present at CB K8 #3 (GY) and not to CB K8 #4 (GY), BC is open. See "III.B.4. Bin Control Check."
- e) **Float Switch (LFS and UFS)** – CB K8 #5 (BK) (common), CB K8 #6 (R) (upper), and CB K8 #7 (BU) (lower): 5VDC is present from CB K7:1 red connector (open) pin 1, (closest to CB K8:2 white connector) to CB K8 #5 (BK) (common) at all times. If not, replace CB. 5VDC is present from CB K7:1 red connector (open) pin 1, (closest to CB K8:2 white connector) to CB K8 #6 (R) (upper) and CB K8 #7 (BU) (lower) when FS is open. If 5VDC is present between CB K8 #5 (BK) and CB K8 #6 (R) (upper) or CB K8 #7 (BU) (lower), FS is open. For further FS diagnostics, see "III.B.5. Float Switch Check and Cleaning."

- 4) **Fill "WTRIN" LED is on:** 24VAC is present at CB K2 #9 (W/R) at all times. If not, confirm 24VAC from CB K2 #9 (W/R) to a neutral (LBU). When LFS open at startup or opens during normal operation, "WTRIN" LED turns on, fill timer (FT) starts, freeze timer (FZT) terminates (only during normal operation), and WV energizes. If LFS is open and "WTRIN" LED is off, confirm LFS status. See "III.B.5. Float Switch Check and Cleaning." If LFS is open and "WTRIN" LED is off, replace CB. If "WTRIN" LED is on and WV is not energized, check for 24VAC at CB K2 #8 (O) to a neutral (LBU). If 24VAC is not present at CB K2 #8 (O), replace CB. "WTRIN" LED turns off once UFS closes. If not, confirm UFS status. See "II.E. Float Switch Check and Cleaning." If UFS is closed and "WTRIN" LED is on, replace CB. If "WTRIN" LED is off and WV is open, check for 24VAC at CB K2 #8 (O). If 24VAC is present at CB K2 #8 (O), replace CB. If 24VAC is not present, check WV diaphragm.
- 5) **Ice Purge Cycle "GM" LED is on:** When UFS closes, GM delay timer starts (5 or 30 sec. depending on CB S2 dip switch #7). Once GM delay timer terminates, "GM" LED turns on, GM and EH (-C model) energize and 5-min. ice purge timer starts. If GM does not energize 5 sec. after UFS closes, confirm UFS status. See "III.B.5. Float Switch Check and Cleaning." If UFS is closed and GM LED does not turn, replace CB. If "GM" LED is on and GM and EH (-C model) are off, check for 115VAC from CB K1 #2 (BK) to a neutral (W). If 115VAC is not present, check 115VAC power supply connections from power switch. If 115VAC is present, check for 115VAC from CB K1 #3 (P) to a neutral (W). If 115VAC is present on CB K1 #2 (BK) and not on CB K1 #3 (P), replace CB.
- 6) **Freeze Cycle "GM" and "COMP" LED are on:** The 5-min. ice purge timer terminates or the ice purge cycle bypass button ("SERVICE") is pressed, "COMP" LED turns on. To bypass the 5-min. Ice Purge Cycle, press the "SERVICE" button on CB after the "GM" LED turns on. **WARNING! Risk of electric shock. Care should be taken not to touch live terminals.** 115VAC is present between CB X1 relay power supply black (BK) wire and neutral (W) at all times. If not, check 115VAC power supply wire connections from power switch. If "COMP" LED is not on after 5-min. ice purge timer terminates, replace CB. When "COMP" LED turns on, CR and Comp energize. If "COMP" LED is on and compressor relay (CR) and Comp are not, check for 115VAC from CB X1 relay power supply black (BK) wire to neutral (W). If 115VAC is present, check X1 relay violet (V) wire to neutral (W). If 115VAC is present on X1 relay black (BK) and not on X1 relay violet (V), replace CB.
- 7) **Refill "WTRIN" LED is on:** See "4) Fill "WTRIN" LED is on:" above.
- 8) **Shutdown:** See "III.B.3.12) Shutdown".

Legend: **BC**—bin control; **CB**—control board; **Comp**—compressor; **CR**—compressor relay; **CCR**—compressor control relay; **EH**—evaporator heater (-C model); **FS**—float switch; **GM**—gear motor; **LFS**—lower float switch; **UFS**—upper float switch; **WV**—inlet water valve

Control Board

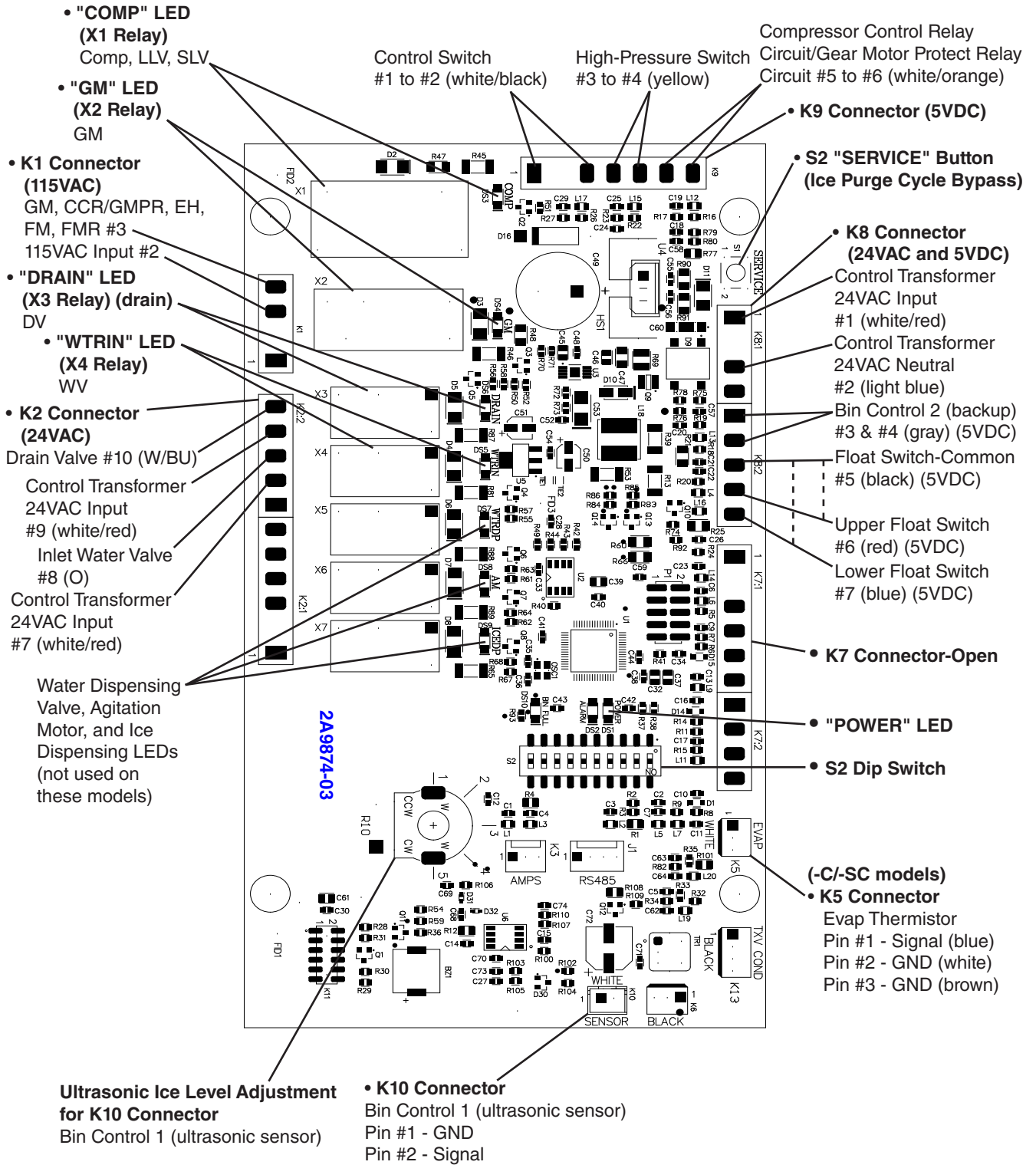

| Control Board | |
|---------------|-----------|
| Part Number | 2A9874-03 |

4. Bin Control Check

When the actuator paddle is not engaged BC is closed and the icemaker produces ice. With CB S2 dip switch 7 placed in the "OFF" position, BC is used as a stand-alone bin control. The stand-alone application should only be used in standard ice storage bin applications. When ice fills the chute and engages the actuator paddle, BC opens and starts CB shutdown sequence.

- 1) Remove the front panel and move the power switch to the "OFF" position, then unplug the icemaker from the electrical outlet.
- 2) Open the icemaker ice storage bin door so that you can access the actuator paddle located in the top of the bin. See Fig. 2.
- 3) Remove the rear cover. Next remove the 12 pin connector plug from the control box. See Fig. 3.

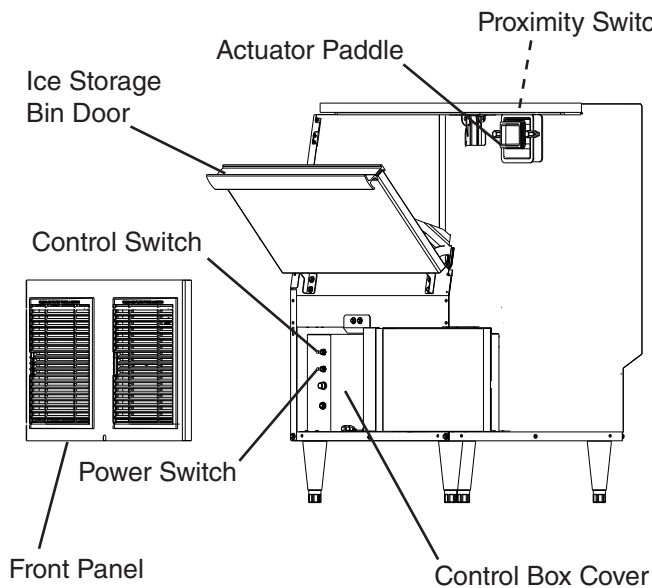

Fig. 2

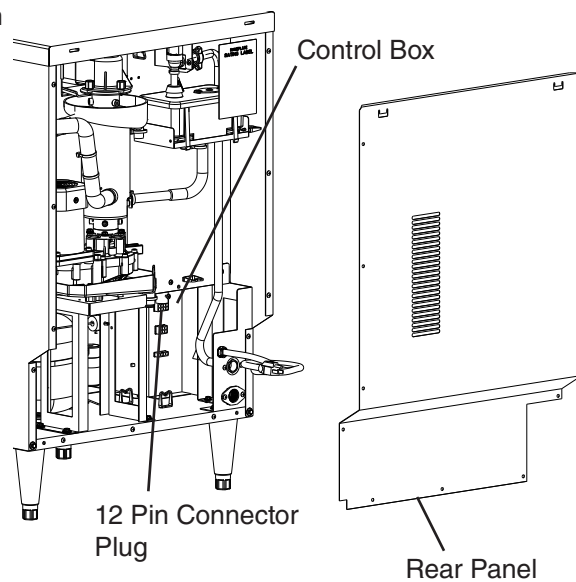

Fig. 3

- 4) With actuator paddle not engaged, check for continuity across BC GY wires (proximity switch) in 12 pin connector plug. BC closed. If BC continuity indicates open BC with the actuator paddle engaged, replace BC (proximity switch).
- 5) Press the actuator paddle located in the top of the bin to the right (actuator paddle engaged). Check for continuity across BC GY wires (proximity switch) in 12 pin connector plug. BC open. If BC continuity indicates closed BC with the actuator paddle engaged, replace BC (proximity switch).
- 6) Reconnect the 12 pin connector plug to the control box.

- 7) Remove the control box anchor screw and swing the control box to the right for control board access. See Fig. 4.

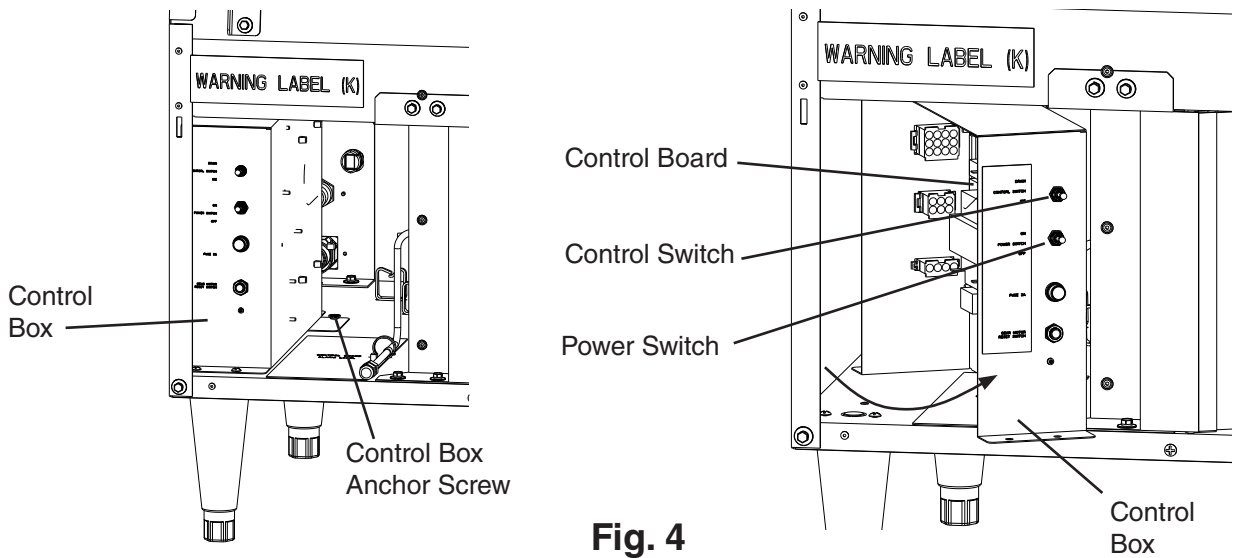

Fig. 4

- 8) Make sure the control switch is in the "ICE" position, then plug the icemaker into the electrical outlet and move the power switch to the "ON" position to start the automatic icemaking process.
- 9) Make sure CB "GM" LED is on. There is a delay of at least 5 sec. before "GM" LED turns on after power-up. After "GM" LED turns on, press CB "SERVICE" button to bypass the 5-min. compressor delay. **WARNING! Risk of electric shock. Care should be taken not to touch live terminals.** The "COMP" LED turns on.
- 10) Press the actuator paddle located in the top of the bin toward the front of the icemaker. See Fig. 2. The 90-sec. Comp shutdown timer starts. Once 90-sec. Comp shutdown timer terminates, Comp and FM de-energize and 60-sec. GM shutdown timer starts. Once 60-sec. GM shutdown timer terminates, GM de-energizes.
Diagnosis: If BC proximity switch is found open and the icemaker continues to run, replace CB.
- 11) Move the power switch to the "OFF" position, then unplug the icemaker from the electrical outlet.
- 12) Replace and secure the control box in its correct position.
- 13) Replace the rear cover in its correct position.
- 14) Move the power switch to the "ON" position, then replace the front panel.
- 15) Close the ice storage bin door.
- 16) Plug the icemaker into the electrical outlet to start the automatic icemaking process.

Legend: **BC**—bin control; **CB**—control board; **Comp**—compressor; **FM**—fan motor; **GM**—gear motor

5. Float Switch Check and Cleaning

a) Float Switch Check

A dual float switch is used to determine that there is sufficient water in the reservoir during fill and refill. CB monitors UFS to de-energize WV when UFS closes during fill and refill. CB monitors LFS to energize WV when LFS opens during the freeze cycle (refill). CB monitors the time between LFS opening and UFS closing (90-sec. low water safety). CB also monitors the time between UFS closing and LFS opening (30-min. freeze timer). No adjustment is required.

- 1) Remove the front panel. Next, move the power switch to the "OFF" position, then move the control switch to the "DRAIN" position.
- 2) Move the power switch to the "ON" position to drain the icemaker.
- 3) After the water has drained, move the power switch to the "OFF" position and unplug the icemaker from the electrical outlet.
- 4) Disconnect the FS moxex plug from the control box and check continuity across FS wires. (BK) to (R) for UFS and (BK) to (BU) for LFS. See Fig. 5. With the water reservoir empty, FS switches are open. If open, continue to step 5. If closed, follow the steps in "III.B.5.b) Float Switch Cleaning." After cleaning the floats, check them again. Replace if necessary.
- 5) Reconnect the FS moxex plug on the control box.
- 6) Plug the icemaker back into the electrical outlet. Next, move the control switch to the "ICE" position, then move the power switch to the "ON" position and let the water reservoir fill.
- 7) Once the reservoir is full and GM starts, move the power switch to the "OFF" position, then unplug the icemaker from the electrical outlet.
- 8) Disconnect the FS moxex plug from the control box and check continuity across FS wires. (BK) to (R) for UFS and (BK) to (BU) for LFS. With the water reservoir full, FS switches are closed. If open, follow the steps in "III.B.5.b) Float Switch Cleaning." After cleaning the floats, check them again. Replace if necessary.
- 9) Reconnect the FS moxex plug on the control box.
- 10) Plug the icemaker back into the electrical outlet. Next, move the power switch to the "ON" position to start the automatic icemaking process.
- 11) Replace the front panel in its correct position.

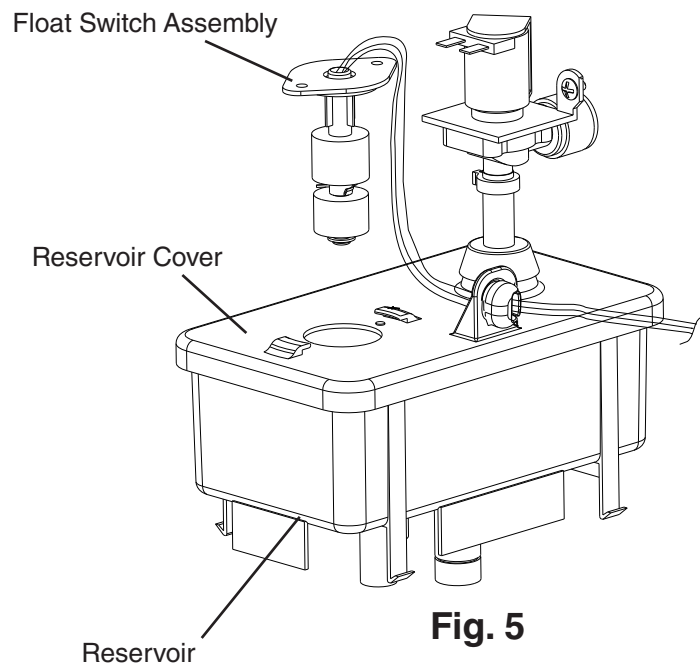

Fig. 5

b) Float Switch Cleaning

Depending on local water conditions, scale may build up on FS. Scale on FS can cause the floats to stick. In this case, FS should be cleaned and checked.

- 1) If not already removed, remove the front panel.
- 2) Move the power switch to the "OFF" position, then unplug the icemaker from the electrical outlet.
- 3) Remove the float switch assembly from the reservoir cover. See Fig. 5.
- 4) Wipe down FS assembly with a mixture of 1 part Hoshizaki "Scale Away" and 25 parts warm water.
- 5) While not necessary, the floats can be removed from the shaft during cleaning. If you remove them, note that the blue float is on top. The floats must be installed with the magnets inside them towards the top of the switch. See Fig. 6. Installing the floats upside down will affect the timing of FS operation.
- 6) Rinse FS assembly thoroughly with clean water and replace in its correct position.
- 7) Plug the icemaker back into the electrical outlet, confirm the control switch is in the "ICE" position, then move the power switch to the "ON" position to start the automatic icemaking process.
- 8) Replace the front panel in its correct position.

Legend: **CB**—control board; **FS**—float switch; **GM**—gear motor; **LFS**—lower float switch; **UFS**—upper float switch; **WV**—inlet water valve

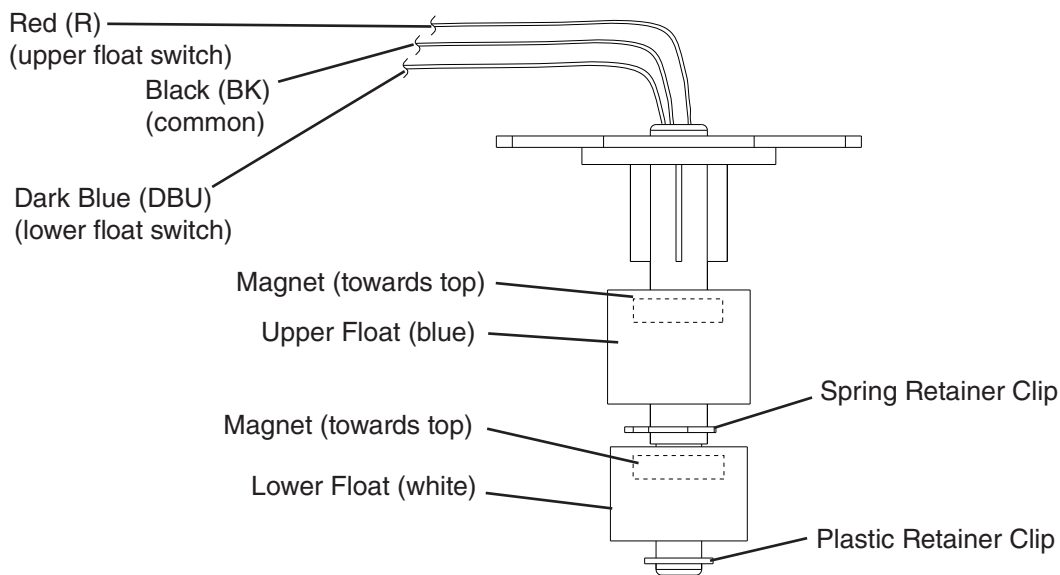

Fig. 6

6. Diagnostic Tables

Before consulting the diagnostic charts, check for correct installation, proper voltage per icemaker nameplate, and adequate water supply. Check control board using the steps in "II.C. Control Board Check."

a) No Ice Production

| No Ice Production - Possible Cause | |
|--|---|
| Startup | |
| 1. Power Supply | a) Unplugged, off, blown fuse, or tripped breaker. b) Not within specifications. |
| 2. Water Supply | a) Water supply off or improper water pressure (10 to 113 PSIG). b) External water filters clogged. |
| 3. Power Switch | a) "OFF" position. |
| 4. Control Transformer (115V/24V) | a) Coil winding open or shorted. |
| 5. Fuse (3A) | a) Blown. |
| 6. Bin Control See "III.B.4. Bin Control Check." | a) Open. b) Defective. |
| 7. Control Switch | a) In "DRAIN" position. b) Defective. |
| 8. Compressor Control Relay | a) Defective. |
| 9. Evaporator Heater (-C model) | a) Defective. |
| Startup/Fill Cycle (reservoir empty) | |
| 1. Control Board | a) Defective. |
| 2. Inlet Water Valve | a) Screen or orifice clogged. b) Defective. |
| Startup/Ice Purge Cycle (reservoir full) | |
| 1. Float Switch See "III.B.5. Float Switch Check and Cleaning." | a) Float does not move freely. b) Defective. |
| 2. High-Pressure Switch | a) Dirty air filter or condenser. b) Condenser fan motor defective. c) Refrigerant overcharge. d) Refrigerant lines or components plugged. |
| 3. Control Board See "III.B.3. Control Board Check." | a) Defective. |
| 4. Gear Motor | a) External or internal protector open. b) Gear motor winding open. c) Mechanical failure. |

| No Ice Production - Possible Cause | |
|--|--|
| Freeze Cycle | |
| 1. Control Board See "III.B.3. Control Board Check." | a) Defective. |
| 2. Start Relay/Capacitor | a) Defective. |
| 3. Compressor | a) Open motor windings. |
| | b) Mechanical Failure. |
| 4. Fan Motor | a) Open motor windings. |
| | b) Mechanical failure or fan blade binding. |
| 5. Evaporator | a) Dirty. |
| | b) Damaged or defective. |
| 6. Refrigerant Charge | a) Low. |
| 7. Drain Valve | a) Dirty, leaking by. |
| 8. Water System | a) Water leaks. |
| 9. Evaporator Heater (-C model) | a) Defective. |
| Refill | |
| 1. Float Switch See "III.B.5. Float Switch Check and Cleaning." | a) Dirty/sticking. |
| | b) Defective. |
| 2. Inlet Water Valve | a) Screen or orifice clogged. |
| | b) Defective. |
| 3. Water Supply | a) Water supply off or improper water pressure (10 to 113 PSIG). |
| | b) External water filters clogged. |
| 4. Control Board See "II.C. Control Board Check." | a) Defective. |
| Shutdown | |
| 1. Bin Control See "III.B.4. Bin Control Check." | a) Proximity switch stuck closed. |
| | b) Actuator paddle does not move freely. |
| 2. Control Board See "III.B.3. Control Board Check." | a) Defective. |
| Drain Cycle | |
| 1. Control Board See "III.B.3. Control Board Check." | a) Defective. |
| 2. Drain Valve | a) Defective. |
| 3. Control Switch | a) Defective. |

7. Control Board and Control Board Layout

- A Hoshizaki exclusive control board is employed.
- All models are pretested and factory adjusted.

NOTICE

- Fragile, handle very carefully.
- The control board contains integrated circuits, which are susceptible to failure due to static discharge. It is especially important to touch the metal part of the icemaker when handling or replacing the control board.
- Do not touch the electronic devices on the control board or the back of the control board.
- Do not change wiring and connections. Do not misconnect terminals.
- Do not short out power supply to test for voltage.
- Always replace the whole control board assembly if it goes bad.

a) Control Board Layout:

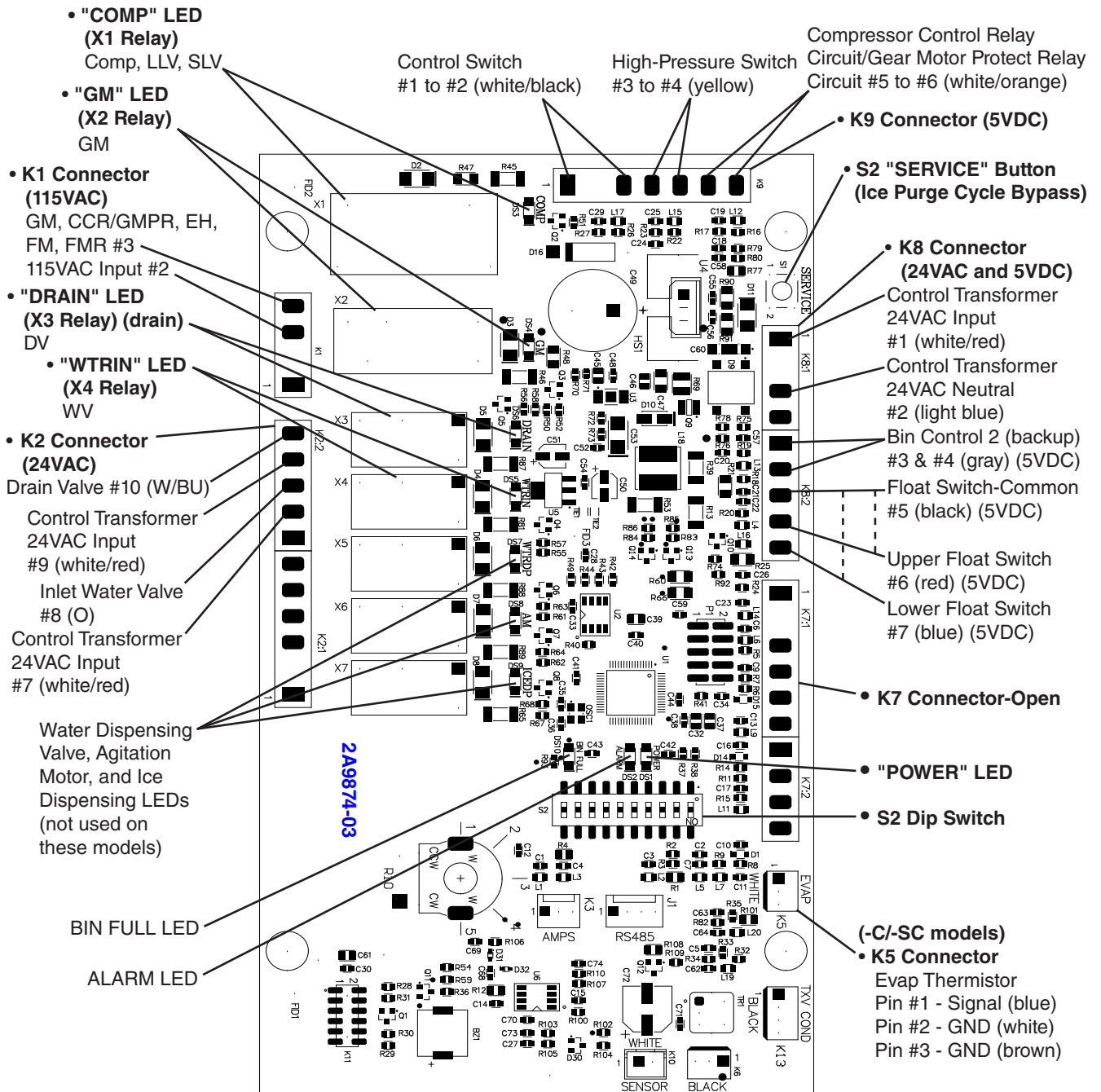

| | |
|----------------------|------------------|
| Control Board | |
| Part Number | 2A9874-03 |

Fig. 7

8. LED Lights and Audible Alarm Safeties

The green "POWER" LED indicates proper control voltage and will remain on unless a control voltage problem occurs.

| Sequence Step | LED | Energized Components | Min. | Max. |
|---|------------------------------|---|------------------------|--|
| Fill Cycle | WTRIN | WV | - | - |
| Ice Purge Cycle | GM | GM, EH, FM/FMR | 5 min. | 5 min. |
| Freeze Cycle (with refill) | GM, WTRIN* (refill), COMP | GM, EH, Comp, FM/FMR, LLV, SLV, WV* (refill) | - | *On until UFS closes. Alarm sounds after 90 sec. |
| Drain Cycle 1-in-1 hr or 1-in-12 hr | DRAIN | 1-in-1: DV 1-in-12: DV (Icemaker status does not change) | 2 sec. (1-in-1 hr.) | 10 min. (1-in-12 hr.) |

In case of an alarm, the built-in safeties shut down the appliance, the orange "ALARM" LED turns on, and audible alarms sound as listed below.

| No. of Beeps (every 5 sec.) | Type of Alarm | Reset Options |
|--------------------------------|---|--|
| 1 | Low-Water Safety UFS open > 90 sec. after WV energized. | Automatic reset once water supply is restored and UFS closes. |
| 2 | Control Switch In "DRAIN" position longer than 15 min. | Automatic reset once the control switch is moved to the "ICE" position. |
| 3 | High-Pressure Switch First and second activation in 1 hr. | Automatic reset once pressure drops below the high pressure threshold and the high-pressure switch closes. |
| 4 | High-Pressure Switch Third activation in 1 hr. | Turn power off. Call for service. To avoid possible catastrophic failure, it is recommended to leave the icemaker off until this alarm is resolved. |
| 5 | Freeze Timer WV off > 30 min. since last WV activation. | Call for service. Manual reset. Turn power off and on again. Check for FS stuck (up), WV leaking by, TXV defective, LLV not opening, low charge, HM not bypassing, or inefficient Comp. |
| 6 | Low Voltage 92VAC \pm 5% or less. | Green "POWER" LED turns off if voltage protection operates. |
| 7 | High Voltage 147VAC \pm 5% or more. | Control voltage safeties automatically reset when voltage is corrected. |
| 8 | a) Gear Motor Fuse or Protector Open CCR contacts fail to close. Used on all models. | Turn power off. Check for GM fuse or protector open. Replace fuse or let protector cool and reset. If persistent trips occur, call for service. |
| | b) Evaporator Thermistor At GM startup Evaporator thermistor < -4°F (-20°C). Used on cubelet (-C)(-SC)(-CB) models only. | Turn power off. Call for service. To avoid possible catastrophic failure, it is recommended to leave the icemaker off until this alarm is resolved. Manual reset. Turn power off and on again. |
| 9 | Bin Control 2 (Mechanical) Open Circuit Control Board K8 (#3 and #4) Not used on DCM or self-contained models. | Manual reset. Turn power off and on again. Modular Flaker and Cubelet (-C)(-SC)(-CB) Models: Control Board S2 Dip Switch #7 must be ON. DCM and Self-Contained Models: Control Board S2 Dip Switch #7 must be OFF. |
| 10 | Evaporator Thermistor Evaporator thermistor reaches -22°F (-30°C) for 3 consecutive cycles. Used on cubelet (-C)(-SC)(-CB) models only. | Turn power off. Call for service. To avoid possible catastrophic failure, it is recommended to leave the icemaker off until this alarm is resolved. Manual reset. Turn power off and on again. |

Legend: **BC**—bin control; **CB**—control board; **CCR**—compressor control relay; **Comp**—compressor; **DV**—drain valve; **EH**—evaporator heater; **FM**—fan motor; **FMR**—fan motor-remote; **GM**—gear motor; **LLV**—liquid line valve (MLJ model only); **MBC**—mechanical backup bin control; **SLV**—suction line valve (MLJ model only); **UFS**—upper float switch; **WV**—inlet water valve

9. Ice Purge Cycle Bypass

To speed up the diagnostic process, the 5-min. ice purge cycle may be bypassed by pressing the "SERVICE" button on the control board after the gear motor starts.

WARNING! Risk of electric shock. Care should be taken not to touch live terminals.

10. Controls and Adjustments

NOTICE

Dip switches are factory set. Failure to maintain factory settings may adversely affect performance and warranty coverage. For more information, contact your Hoshizaki Certified Service Representative.

a) Default Dip Switch Settings

The S2 dip switch settings are factory-set to the following positions:

| Dip Switch No. | 1 | 2 | 3 | 4 | 5 | 6 | 7 | 8 | 9 | 10 |
|----------------|-----|-----|-----|-----|-----|-----|-----|----|-----|-----|
| F-330BAK | OFF | OFF | OFF | OFF | OFF | OFF | OFF | ON | OFF | OFF |
| F-330BAK-C | OFF | OFF | OFF | OFF | OFF | OFF | OFF | ON | OFF | OFF |

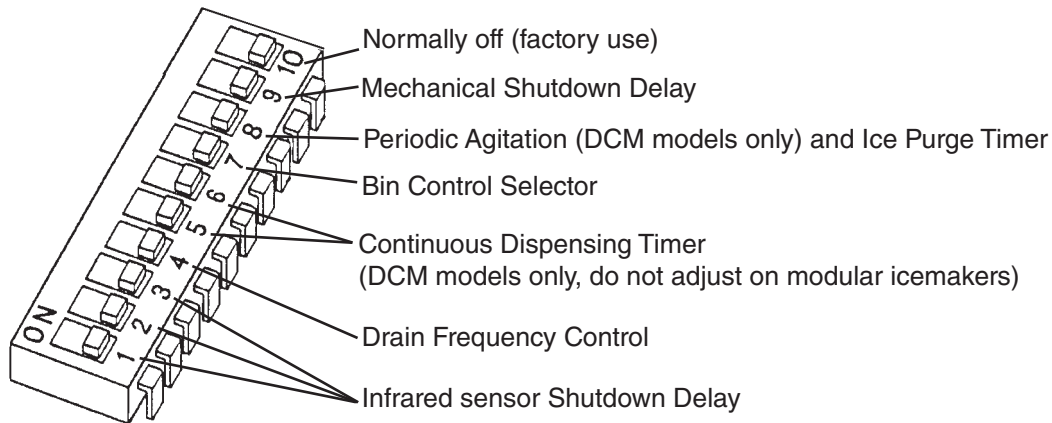

b) Infrared Sensor Shutdown Delay (S2 dip switch 1, 2, 3)

Infrared sensor shutdown delay is the delay between the infrared sensor detecting ice (infrared sensor yellow LED flashing or steady) and the start of the shutdown sequence. For dispenser unit applications, the ice level at shutoff may need to be adjusted depending on the dispenser agitation or dispense method. Increasing the shutdown delay setting allows for a higher level of ice in the bin before the icemaker shuts down. For a typical dispenser unit application, a 100-sec. shutdown delay is recommended. When used with a standard Hoshizaki ice storage bin, any shutdown delay setting is acceptable. **WARNING! Increasing the shutdown delay allows a higher level of ice in the dispenser unit/ice storage bin before shutdown. This could lead to icemaker movement or ice overflow.**

Note: Not used on this model.

| S2 Dip Switch Setting | | | Infrared Sensor Shutdown Delay |
|-----------------------|-------|-------|---|
| No. 1 | No. 2 | No. 3 | |
| OFF | OFF | OFF | 0 Seconds |
| ON | OFF | OFF | 100 Seconds (1.6 minutes) (Factory Default) |
| OFF | ON | OFF | 1100 Seconds (18.3 minutes) |
| OFF | OFF | ON | 1650 Seconds (27.5 minutes) |
| ON | ON | OFF | 2200 Seconds (36.7 minutes) |
| OFF | ON | ON | 0 Seconds |
| ON | ON | ON | 0 Seconds |

c) Drain Frequency Control (S2 dip switch 4)

This dip switch is factory set for optimum performance with the 1-in-1 drain cycle (S2 dip switch 4 in the off position). This setting allows for removal of sediment from the evaporator without interrupting the icemaking process. An optional 1-in-12 drain cycle is available.

| S2 Dip Switch Setting | Drain Timer Interval | Drain Valve Open |
|-----------------------|----------------------|------------------|
| No. 4 | | |
| OFF (1-in-1) | 1 Hour | 2 Seconds |
| ON (1-in-12) | 11 Hours 45 Minutes | 10 Minutes |

d) Continuous Dispensing Timer (S2 dip switch 5 & 6)

DCM models only. The dispense mode switch on DCMs must be in the "CONTINUOUS" position for this setting to apply. The factory setting allows ice to be dispensed continuously as long as the dispense solenoid is activated.

Note: Not used on this model.

| S2 Dip Switch Setting | | Dispense Time |
|-----------------------|-------|---------------|
| No. 5 | No. 6 | |
| OFF | OFF | No Limit |
| ON | OFF | 20 Seconds |
| OFF | ON | 60 Seconds |
| ON | ON | No Limit |

e) Bin Control Selector (S2 dip switch 7)

The bin control selector is factory set. Do not adjust. When used on a standard ice storage bin, only the mechanical bin control should be used. When the mechanical bin control is used (S2 dip switch 7 in the off position), the gear motor delay after the upper float switch closes is 5 sec. **WARNING! Do not place S2 dip switch 7 in the on position on this model. This could lead to no ice operation, control board alarms, or ice overflow.**

| S2 Dip Switch Setting | Bin Control Application | Gear Motor Delay |
|-----------------------|---|------------------|
| No. 7 | | |
| OFF | BC (stand-alone) (Standard Ice Storage Bins Only) | 5 seconds |
| ON | BC1 (infrared sensor) Stand-Alone and BC1 (infrared sensor) with BC2 (mechanical backup) | 30 seconds |

f) Agitation and Ice Purge Timer (S2 dip switch 8)

Not available when S2 dip switch 7 is on. Factory set for normal operation. No adjustment is required. **WARNING! Do not adjust S2 dip switch 8 out of the factory default position. This dip switch must be left in the factory default position or the icemaker will not operate correctly.**

| S2 Dip Switch Setting | Storage Bin Periodic Agitation | Ice Purge Timer |
|-----------------------|--------------------------------|----------------------|
| No. 8 | | |
| OFF | 2 Seconds | 60 Seconds (1 min.) |
| ON | No Agitation | 300 Seconds (5 min.) |

g) Mechanical Shutdown Delay (S2 dip switch 9)

The shutdown delay is the time between the bin control micro-switch opening and the control board shutting down the icemaker. **WARNING! Do not adjust S2 dip switch 9 out of the factory default position. This dip switch must be left in the factory default position or the icemaker will not operate correctly.**

| S2 Dip Switch Setting | Mechanical Shutdown Delay |
|-----------------------|--|
| No. 9 | |
| OFF | 90-60 Second Sequence (150 sec. total) |
| ON | 6 to 10 Seconds |

h) Factory Use (S2 Dip Switch 10)

Factory set for optimum performance. Do not adjust.

11. Power Switch and Control Switch

The power switch and the control switch are used to control the icemaker. They are located on the control box.

a) Power Switch

The power switch has 2 positions, "OFF" and "ON." When the power switch is in the "OFF" position, no power is supplied to the components. When in the "ON" position, power is supplied to the control transformer and control board. The control board then supplies 5VDC to the control switch for unit operation.

b) Control Switch

The control switch has 2 positions, "ICE" and "DRAIN."

When the control switch is in the "ICE" position (open), icemaking begins.

When the control switch is in the "DRAIN" position (closed), the drain valve energizes.

1) ICE

When the control switch is in the "ICE" position, the control board reads an open circuit through the control switch contacts and starts the icemaking process.

2) DRAIN

When the control switch is in the "DRAIN" position, the control board reads a closed circuit through the control switch and the drain valve energizes.

C. Refrigeration Circuit Service



R-290 Class A3 Flammable Refrigerant Used

⚠ DANGER

Risk of Fire or Explosion. Flammable Refrigerant Used.

- Be sure to follow all Important Safety Information located at the beginning of this manual and at the beginning of section "III.A. Safety Precautions When Servicing."
- Servicing shall be done by trained service personnel with certified competence in handling flammable refrigerants to minimize the risk of possible ignition due to incorrect parts or improper service.
- Confirm that capacitors are discharged: this shall be done in a safe manner to avoid possibility of sparking.
- A dry chemical or CO₂ fire extinguisher should be adjacent to the charging area. You must have a Class B chemical fire extinguisher available at all times.
- When breaking into the refrigerant circuit to make repairs – or for any other purpose – conventional procedures shall be used. However, for flammable refrigerants it is important that best practice be followed, since flammability is a consideration. The following procedure shall be adhered to:
 - safely remove refrigerant following local and national regulations
 - purge the circuit with inert gas
 - evacuate (optional for A2L)
 - purge with inert gas (optional for A2L)
 - open the circuit by cutting or brazing
- Confirm that no live electrical components and wiring are exposed while charging, recovering, or purging the system.
- You must have a combustible gas leak detector in the immediate work area at all times.
- Be sure the area is clear of refrigerant vapor before brazing.
- The refrigerant charge shall be recovered into the correct recovery cylinders if venting is not allowed by local and national codes. For appliances containing flammable refrigerants, the system shall be purged with oxygen-free nitrogen to render the appliance safe for flammable refrigerants. This process might need to be repeated several times. Compressed air or oxygen shall not be used for purging refrigerant systems.

⚠ DANGER Continué

Risque De Feu Ou D'Explosion. Fluide Frigorigène Inflammable Utilisé.

- Assurez-vous de suivre toutes les informations importantes de sécurité qui se trouvent au début du présent manuel et au début de la section «III.A. Précautions de sécurité lors de l'entretien.»
- L'entretien doit être effectué par du personnel formé et certifié pour la manipulation de réfrigérants inflammables afin de réduire au minimum le risque d'inflammation dû à des pièces incorrectes ou à un entretien inadéquat.
- S'assurer que les condensateurs sont déchargés : cette opération doit être effectuée en toute sécurité afin d'éviter tout risque d'étincelle.
- Un extincteur à poudre chimique ou à CO₂ devrait être installé à proximité de la zone de chargement. Un extincteur chimique de classe B doit être disponible à tout moment.
- Pour pénétrer dans le circuit du réfrigérant afin d'effectuer des réparations ou pour toute autre raison, des procédures conventionnelles doivent être utilisées. Toutefois, pour les réfrigérants inflammables, il est important de suivre les meilleures pratiques, car l'inflammabilité est un facteur à prendre en considération. La procédure suivante doit être respectée:
 - éliminer le réfrigérant en toute sécurité conformément aux réglementations locales et nationales
 - purger le circuit avec du gaz inerte
 - évacuer (en option pour A2L)
 - purger avec du gaz inerte (en option pour A2L)
 - ouvrir le circuit par coupure ou brasage
- S'assurer qu'aucun composant ou câblage électrique sous tension n'est exposé lors de la charge, de la récupération ou de la purge du système.
- Vous devez avoir un détecteur de fuite de gaz combustible dans la zone de travail immédiate en tout temps.
- Assurez-vous que la zone est dégagée de la vapeur de réfrigérant avant de braser.
- La charge réfrigérante doit être récupérée dans les bouteilles de récupération correctes si la ventilation n'est pas autorisée par les codes locaux et nationaux. Pour les appareils contenant des réfrigérants inflammables, le système doit être purgé avec de l'azote exempt d'oxygène pour assurer la sécurité de l'appareil pour les réfrigérants inflammables. Ce processus peut être répété plusieurs fois. L'air comprimé ou l'oxygène ne doivent pas être utilisés pour la purge des systèmes de réfrigérants.

⚠ WARNING

- Wear appropriate personal protective equipment (PPE) when servicing the appliance.
- Notify all persons in the immediate area that you are working with a flammable refrigerant.
- Do not use silver alloy or copper alloy containing arsenic.

a) Refrigerant Recovery

Using proper refrigerant practices, place piercing valves toward the end (crimped area) of the high and low-side process tubes, then recover the refrigerant into an approved container or device.

- 1) Move the control switch to the "OFF" position, then unplug the appliance from the electrical outlet.

b) Brazing

- 2) Prior to brazing, purge with nitrogen gas for 2 min., flowing at a pressure of 3 to 5 PSIG.

⚠ DANGER! For appliances containing flammable refrigerants, the system shall be purged with oxygen-free nitrogen to render the appliance safe for flammable refrigerants. This process might need to be repeated several times. Compressed air or oxygen shall not be used for purging refrigerant systems.

- 3) Braze/repair/replace damaged component or fittings while purging with nitrogen gas, flowing at a pressure of 3 to 5 PSIG.

NOTICE

- Do not leave the system open for longer than 15 min. when replacing or servicing parts. The Polyol Ester (POE) oils used in R-290 applications can absorb moisture quickly. Therefore it is important to prevent moisture from entering the system when replacing or servicing parts.
- Always install a new drier every time the sealed refrigeration system is opened. Do not replace the drier until after all other repair or replacement has been made. Install the new drier with the arrow on the drier in the direction of the refrigerant flow.
- When brazing, protect the drier by using a wet cloth to prevent the drier from overheating. Do not allow the drier to exceed 250°F (121°C).

- 4) Use soap bubbles to check for leaks. Raise the pressure using nitrogen gas (190 PSIG). Do not use any refrigerant as a mixture with pressurized air for leak testing.
- 5) Once leak checking is complete, release the nitrogen gas from the system.

c) Evacuation

- 6) Attach a vacuum pump to the system. Be sure the high-side charging hose is connected to the field-installed high-side access valve.

IMPORTANT

The vacuum level and vacuum pump may be the same as those for current refrigerants. However, the rubber hose and gauge manifold to be used for evacuation and refrigerant charge should be exclusively for POE oils.

- 7) Turn on the vacuum pump, then open the high-side valve on the gauge manifold. Never allow the oil in the vacuum pump to flow backwards.
- 8) Allow the vacuum pump to pull down to a 29.9" Hg vacuum. Evacuating period depends on pump capacity.

- 9) Close the high-side valve on the gauge manifold.
- 10) Disconnect the gauge manifold hose from the vacuum pump and attach it to a refrigerant service cylinder. Remember to loosen the connection and purge the air from the hose. See the nameplate for the required refrigerant charge. Hoshizaki recommends only virgin refrigerant or reclaimed refrigerant which meets the requirements of AHRI Standard 700 (latest edition) be used.

d) Recharge

⚠ DANGER

- In addition to conventional charging procedures, the following requirements shall be followed:
 - Ensure that contamination of different refrigerants does not occur when using charging equipment. Hoses or lines shall be as short as possible to minimize the amount of refrigerant contained in them.
 - Cylinders shall be kept in an appropriate position according to the instructions.
 - Ensure that the refrigerating system is earthed (grounded) prior to charging the system with refrigerant.
 - Label the system when charging is complete (if not already).
 - Extreme care shall be taken not to overfill the refrigerating system.
- The system shall be leak-tested on completion of charging but prior to commissioning. A follow up leak test shall be carried out prior to leaving the site.

- En plus des procédures de charge conventionnelles, les exigences suivantes doivent être respectées :
 - S'assurer qu'aucune contamination de différents réfrigérants ne se produit lors de l'utilisation de l'équipement de charge. Les tuyaux ou conduites doivent être aussi courts que possible afin de minimiser la quantité de réfrigérant qu'ils contiennent.
 - Les bouteilles doivent être maintenues dans une position appropriée conformément aux instructions.
 - S'assurer que le système de réfrigération soit mis à la terre avant de charger le système avec du réfrigérant.
 - Étiqueter le système lorsque la charge est terminée (si cela n'a pas déjà été fait).
 - Il faut veiller à ne pas trop remplir le système de réfrigération.
- Avant de recharger le système, celui-ci doit être testé sous pression avec le gaz de purge approprié. Le système doit être soumis à un essai de fuite à la fin de la charge, mais avant la mise en service. Un test de contrôle de fuite doit être effectué avant de quitter le site.

- 11) R-290 can be charged in either the liquid or vapor state. Liquid charge is preferred. If refrigerant charging is done in the liquid state, place the service cylinder on the scales; **if the service cylinder is not equipped with a dip tube, invert the service cylinder, then place it on the scales.** Open the high-side valve on the gauge manifold.

- 12) Allow the system to charge with liquid until the proper charge weight is met.
- 13) Close the high-side valve on the gauge manifold. If charging is complete, skip to step 15.
- 14) If necessary, add any remaining charge to the system through the low-side.
NOTICE! To prevent compressor damage, use a throttling valve or liquid dispensing device to add the remaining liquid charge through the low-side refrigerant access valve with the compressor running. Close the refrigerant cylinder valve and let the low-side refrigerant equalize to the system, then close the low-side manifold gauge.
- 15) Pinch off (crimp down) the process tubes just below the piercing valves.
- 16) Remove the piercing valves. Cut the process tubes to remove the piercing valve holes.
- 17) Confirm there are no leaks from the pinched off process tubes, then braze the process tubes closed. **⚠ DANGER! Be sure there is no refrigerant leak before brazing.**
- 18) Use a combustible gas leak detector or soap bubbles to check for leaks again.
- 19) Place red sleeves over the process tubes.
- 20) Plug the icemaker back into the electrical outlet.

D. Component Service Information

| | |
|--|--|
|  | R-290 Class A3 Flammable Refrigerant Used |
| ⚠ DANGER | |
| <u>Risk of Fire or Explosion. Flammable Refrigerant Used.</u> | |
| <ul style="list-style-type: none"> • Be sure to follow all Important Safety Information located at the beginning of this manual and at the beginning of section "III.A. Safety Precautions When Servicing." • Component parts shall be replaced with like components. So as to minimize the risk of possible ignition due to incorrect parts. • This appliance should be diagnosed and repaired only by qualified service personnel to reduce the risk of death, electric shock, serious injury, or fire. • Repair and maintenance to electrical components shall include initial safety checks and component inspection procedures. If a fault exists that could compromise safety, then no electrical supply shall be connected to the circuit until it is satisfactorily dealt with. If the fault cannot be corrected immediately but it is necessary to continue operation, an adequate temporary solution shall be used. This shall be reported to the owner of the equipment, so all parties are advised. • Confirm that capacitors are discharged: this shall be done in a safe manner to avoid possibility of sparking. • Confirm that no live electrical components and wiring are exposed while charging, recovering, or purging the system. • Confirm that there is continuity of earth bonding (grounding). | |

⚠ DANGER Continué

Risque D'Incendie ou D'Explosion. Fluide Frigorigène Inflammable Utilisé.

- Assurez-vous de suivre toutes les informations importantes de sécurité qui se trouvent au début du présent manuel et au début de la section «III.A. Précautions de sécurité lors de l'entretien.»
- Les pièces doivent être remplacées par des pièces similaires, de manière à réduire au minimum le risque d'inflammation dû à des pièces incorrectes.
- Cet appareil ne doit être diagnostiqué et réparé que par un personnel qualifié afin de réduire les risques de mort, d'électrocution, de blessures graves ou d'incendie.
- La réparation et l'entretien des composants électriques incluent les contrôles de sécurité initiaux et les procédures d'inspection des composants. En cas de défaut susceptible de compromettre la sécurité, aucune alimentation électrique ne doit être connectée au circuit tant que le problème n'a pas été résolu de manière satisfaisante. Si le défaut ne peut être corrigé immédiatement mais qu'il est nécessaire de poursuivre l'exploitation, une solution temporaire adéquate doit être utilisée. Cela doit être signalé au propriétaire de l'équipement, afin que toutes les parties soient informées.
- S'assurer que les condensateurs sont déchargés : cette opération doit être effectuée en toute sécurité afin d'éviter tout risque d'étincelle.
- S'assurer qu'aucun composant ou câblage électrique sous tension n'est exposé lors de la charge, de la récupération ou de la purge du système.
- S'assurer de la continuité de la mise à la terre.

NOTICE

When replacing a component listed below, see the notes to help ensure proper operation.

| Component | Notes |
|--------------------------|--|
| Compressor | <ul style="list-style-type: none">• Install a new drier, start capacitor, and start relay. |
| Upper and Lower Bearings | <ul style="list-style-type: none">• Inspect the upper bearing for wear. See "III.D.1. Upper Bearing Wear Check." Replace if necessary.• When replacing the upper bearing it is advised to also change the lower bearing at the same time. |
| Evaporator | <ul style="list-style-type: none">• Install a new drier.• Inspect the mechanical seal and O-ring prior to installing the new evaporator. If worn, cracked, or scratched, the mechanical seal should also be replaced. |
| Gear Motor | <ul style="list-style-type: none">• Install a new gear motor capacitor. |

Evaporator Assembly

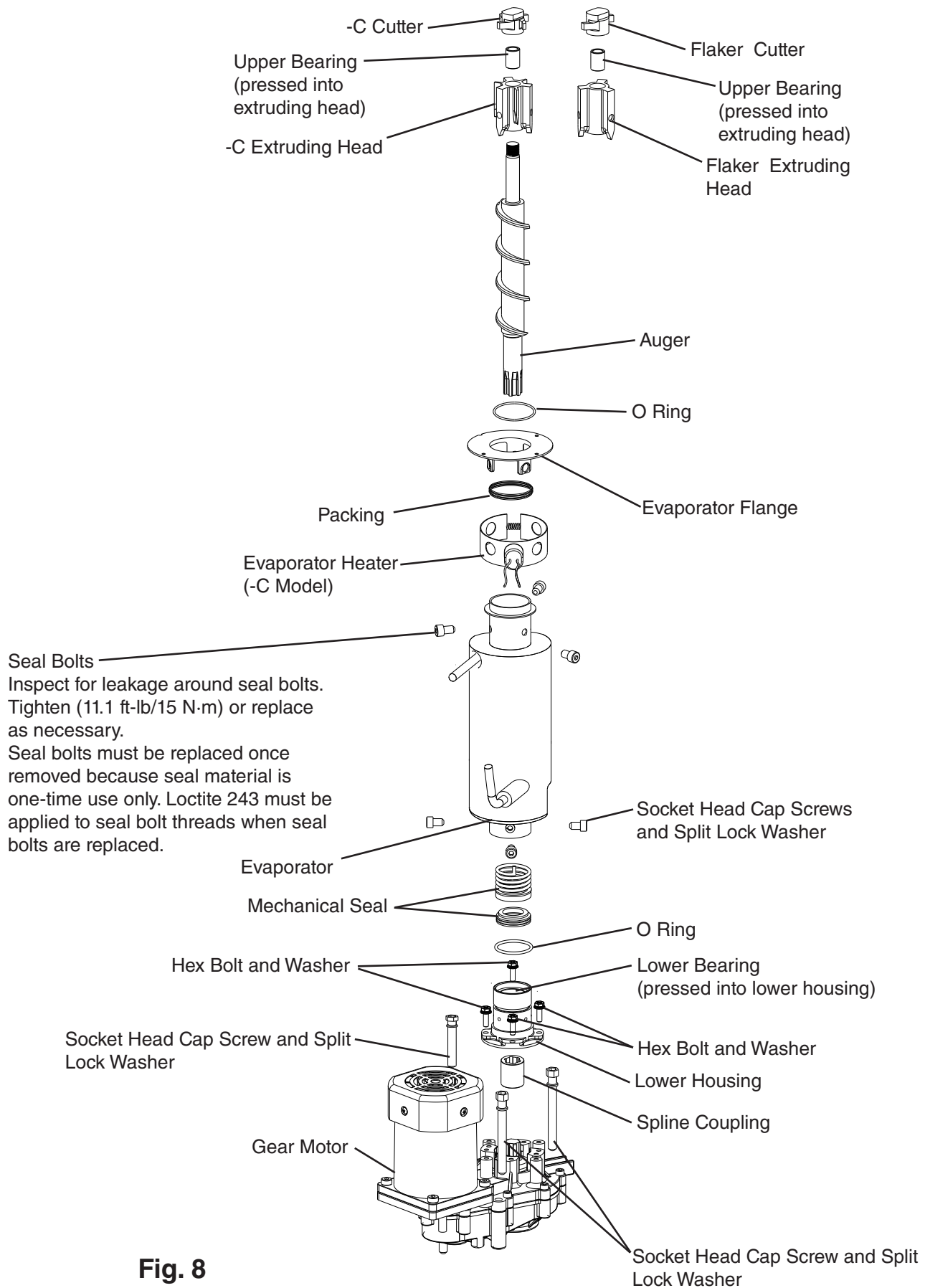

Fig. 8

1. Upper Bearing Wear Check

To ensure that the bearing inside the extruding head does not exceed the wear tolerance of .02", follow the instructions below.

- 1) Remove the front panel. Move the power switch to the "OFF" position, then turn off the power supply.
- 2) Remove the top and side panels.
- 3) Remove the strap connecting the spout to the chute assembly, then remove the spout.
- 4) Remove the bolt (if applicable) or cutter from the auger and lift off the cutter and washer (if applicable).

- 5) Replace the bolt in the auger (if applicable). See Fig. 9. Move the auger towards you and then try to insert a .02" round stock or pin gauge in between the back side of the auger shaft and the bearing surface. Check several locations around the auger shaft. If the gauge goes between the shaft and the bearing at any point or if the bearing is scratched or cracked, both the top bearing in the extruding head and the lower bearing in the housing should be replaced. Instructions for removing the extruding head and housing are located later in this procedure.

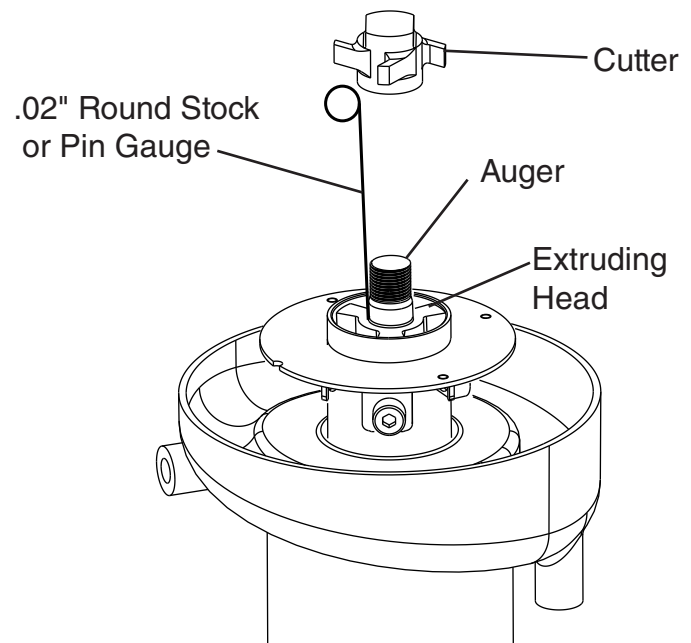

Fig. 9

Note: Replacing the bearing requires a bearing press adaptor. If one is not available, replace the whole extruding head and housing.

- 6) Replace the washer (if applicable), cutter, and cutter bolt (if applicable).
- 7) Replace the spout.
- 8) Replace the top and side panels in their correct positions.
- 9) Move the power switch to the "ON" position, then turn on the power supply.
- 10) Replace the front panel in its correct position.

2. Removal and Replacement of Cutter

- 1) Remove the front panel. Move the power switch to the "OFF" position, then turn off the power supply.
- 2) Remove the top and side panels.
- 3) Remove the strap connecting the spout to the chute assembly, then remove the spout.
- 4) Remove the bolt (if applicable) or cutter and lift off the cutter.
- 5) Install the new cutter. Replace the bolt (if applicable).
- 6) Replace the spout.
- 7) Replace the top and side panels in their correct position.
- 8) Move the power switch to the "ON" position, then turn on the power supply.
- 9) Replace the front panel in its correct position.

IMPORTANT! Seal Bolt Removal and Installation Instructions: Seal bolts must be replaced once removed because seal material is one-time use only. If new seal bolts do not have preapplied threadlocker, apply Loctite 243 or equivalent threadlocker to seal bolt threads.

- Torque for F-330BAK(-C): 11.1 ft-lb/15 N·m. Tighten 2 times. Allow at least 5 sec. in between each tightening.

3. Removal and Replacement of Extruding Head

- 1) Drain the water from the evaporator.
 - a) Remove the front panel, then move the power switch to the "OFF" position.
 - b) Move the control switch to the "DRAIN" position.
 - c) Move the power switch to the "ON" position and allow the water to drain from the evaporator.
 - d) Move the power switch to the "OFF" position, then turn off the power supply.
- 2) Remove the top and side panels.
- 3) Remove the strap connecting the spout to the chute assembly, then remove the spout.
- 4) Remove the cutter bolt (if applicable) or cutter and lift off the cutter and washer (if applicable).
- 5) Remove the seal bolts from the extruding head and lift off the extruding head.
- 6) Place the new extruding head in place and tighten down with new seal bolts. See "Seal Bolt Removal and Installation Instructions" above.
- 7) Replace the washer (if applicable), cutter, cutter bolt (if applicable), and spout.
- 8) Replace the top and side panels in their correct positions.
- 9) Move the control switch to the "ICE" position.
- 10) Move the power switch to the "ON" position, then turn on the power supply.
- 11) Replace the front panel in its correct position.

4. Removal and Replacement of Auger

- 1) Drain the water from the evaporator.
 - a) Remove the front panel, then move the power switch to the "OFF" position.
 - b) Move the control switch to the "DRAIN" position.
 - c) Move the power switch to the "ON" position and allow the water to drain from the evaporator.
 - d) Move the power switch to the "OFF" position, then turn off the power supply.
- 2) Remove the top and side panels.
- 3) Remove the strap connecting the spout to the chute assembly, then remove the spout.
- 4) Remove the extruding head seal bolts. Using the cutter, lift out the auger assembly.
- 5) Remove the cutter bolt (if applicable), cutter, washer (if applicable), and dowel pin (if applicable). Remove the extruding head from the auger and place on the new auger.
- 6) Install the new auger.
- 7) Replace the removed parts in the reverse order of which they were removed.
Note: Be sure to use new seal bolts. See "Seal Bolt Removal and Installation Instructions" above.
- 8) Replace the top and side panels in their correct positions.
- 9) Move the control switch to the "ICE" position.
- 10) Move the power switch to the "ON" position, then turn on the power supply.
- 11) Replace the front panel in its correct position.

5. Removal and Replacement of Evaporator

IMPORTANT

Install a new drier every time the sealed refrigeration system is opened. Do not replace the drier until after all other repair or replacement has been made.

- 1) Drain the water from the evaporator.
 - a) Remove the front panel, then move the power switch to the "OFF" position.
 - b) Move the control switch to the "DRAIN" position.
 - c) Move the power switch to the "ON" position and allow the water to drain from the evaporator.
 - d) Move the power switch to the "OFF" position, then turn off the power supply.
- 2) Remove the top and side panels.
- 3) Recover the refrigerant and store it in an approved container.
- 4) Remove the strap connecting the spout to the chute assembly, then remove the spout.
- 5) Disconnect the water hoses.
- 6) Remove the extruding head seal bolts. Using the cutter, lift out the auger assembly.
- 7) Remove the insulation and the expansion valve bulb on the suction line.
- 8) Disconnect the evaporator inlet and outlet tubing.
- 9) Remove the socket head cap screws and split lock washers securing the evaporator to the lower housing.
- 10) Lift off the evaporator.
- 11) Inspect the mechanical seal and O-ring prior to installing the new evaporator. The mechanical seal consists of two parts. One moves along with the auger, and the other is fixed on the lower housing. If the contact surfaces of these two parts are worn, cracked, or scratched, the mechanical seal may cause water leaks and should be replaced. Instructions for removing the mechanical seal and lower housing are located later in this procedure.
- 12) Make sure the lower mechanical seal is in place, then place the evaporator in position. Secure the evaporator to the lower housing using the socket head cap screws and split lock washers.
- 13) Remove the drier, then place the new drier in position.
- 14) Braze/repair/replace damaged component or fittings while purging with nitrogen gas, flowing at a pressure of 3 to 5 PSIG.
- 15) Use an electronic leak detector or soap bubbles to check for leaks. Add a trace of refrigerant to the system (if using an electronic leak detector), and then raise the pressure using nitrogen gas (140 PSIG). Do not use R-290 as a mixture with pressurized air for leak testing.
- 16) Evacuate the system, and charge it with refrigerant. See the nameplate for the required refrigerant charge.

- 17) Replace the removed parts in the reverse order of which they were removed.
Note: Be sure to use new seal bolts. See "Seal Bolt Removal and Installation Instructions" in "2. Removal and Replacement of Cutter", step 9.
- 18) Replace the top and side panels in their correct positions.
- 19) Move the control switch to the "ICE" position.
- 20) Move the power switch to the "ON" position, then turn on the power supply.
- 21) Replace the front panel in its correct position.

6. Removal and Replacement of Mechanical Seal and Lower Housing

a. Mechanical Seal

- 1) Drain the water from the evaporator.
 - a) Remove the front panel, then move the power switch to the "OFF" position.
 - b) Move the control switch to the "DRAIN" position.
 - c) Move the power switch to the "ON" position and allow the water to drain from the evaporator.
 - d) Move the power switch to the "OFF" position, then turn off the power supply.
- 2) Remove the top and side panels.
- 3) Remove the strap connecting the spout to the chute assembly, then remove the spout.
- 4) Remove the extruding head seal bolts. Using the cutter, lift out the auger assembly.
- 5) The mechanical seal consists of two parts. One moves along with the auger, and the other is fixed on the lower housing. If the contact surfaces of these two parts are worn, cracked, or scratched, the mechanical seal may cause water leaks and should be replaced.
- 6) Remove the socket head cap screws and split lock washers securing the evaporator to the lower bearing housing.
- 7) Raise the evaporator up to access the lower housing.
- 8) Remove the O-ring and mechanical seal from the housing. If only replacing the mechanical seal, proceed to step 11.

NOTICE

To help prevent water leaks, be careful not to damage the surfaces of the O-ring or mechanical seal.

b. Lower Housing

- 9) Remove the hex bolts w/washers securing the lower housing to the gear motor and remove the lower housing from the gear motor. If inspection of the upper bearing inside the extruding head (see "III.D.1. Upper Bearing Wear Check") indicates that it is out of tolerance, replace both it and the bearing inside the lower housing.
Note: Replacing the bearing requires a bearing press adaptor. If one is not available, replace the whole extruding head and lower housing.
- 10) Mount the lower housing on the gear motor.
- 11) Install the O-ring and lower part of the mechanical seal on the lower housing.
- 12) Make sure the lower mechanical seal is in place, then place the evaporator in position. Secure the evaporator to the lower housing using the socket head cap screws and split lock washers.
- 13) Install the auger assembly with the upper part of the mechanical seal attached.
- 14) Replace the removed parts in the reverse order of which they were removed.
Note: Be sure to use new seal bolts. See "Seal Bolt Removal and Installation Instructions" earlier in this section.
- 15) Replace the top and side panels in their correct positions.
- 16) Move the control switch to the "ICE" position.
- 17) Move the power switch to the "ON" position, then turn on the power supply.
- 18) Replace the front panel in its correct position.

7. Removal and Replacement of Gear Motor

- 1) Drain the water from the evaporator.
 - a) Remove the front panel, then move the power switch to the "OFF" position.
 - b) Move the control switch to the "DRAIN" position.
 - c) Move the power switch to the "ON" position and allow the water to drain from the evaporator.
 - d) Move the power switch to the "OFF" position, then turn off the power supply.
- 2) Remove the top and side panels.
- 3) Remove the strap connecting the spout to the chute assembly, then remove the spout.
- 4) Remove the hex head bolts and washers securing the lower housing to the gear motor. Lift the evaporator up slightly.
- 5) Remove the socket head cap screws and split lock washers securing the gear motor.
- 6) Disconnect the gear motor wiring, then remove the gear motor.
- 7) Remove the gear motor bracket and spline coupling from the old gear motor and place on the new gear motor.
- 8) Install the new gear motor and re-connect the electrical wires.
- 9) Replace the removed parts in the reverse order of which they were removed.
- 10) Replace the top and side panels in their correct positions.
- 11) Move the control switch to the "ICE" position.
- 12) Move the power switch to the "ON" position, then turn on the power supply.
- 13) Replace the front panel in its correct position.

IV. Maintenance

The appliance must be maintained in accordance with the instruction manual and labels provided. Consult with your local Hoshizaki Certified Service Representative about maintenance service. To obtain the name and phone number of your local Hoshizaki Certified Service Representative, visit www.hoshizakiamerica.com.

WARNING

- Items listed under "IV.A. User Maintenance Schedule" may be performed by the user; otherwise, only qualified service technicians should service the appliance.
- Failure to install, operate, and maintain the equipment in accordance with this manual will adversely affect safety, performance, component life, and warranty coverage.
- To reduce the risk of electric shock, do not touch the icemaker power switch or control switch with damp hands.
- **Before Servicing:** Move the power switch to the "OFF" position, then unplug the appliance from the electrical outlet. Power switch in "OFF" position does not de-energize all loads.
- **CHOKING HAZARD:** Ensure all components, fasteners, and thumbscrews are securely in place after any maintenance is done to the appliance. Make sure that none have fallen into the ice storage bin.
- Do not place fingers or any other objects into the ice discharge opening.
- After service, make sure that there are no wires pinched between the panels and appliance. Make sure you do not damage or pinch the water supply line, drain line, or power cord.

A. User Maintenance Schedule

The user maintenance schedule below is a guideline. More frequent maintenance may be required depending on water quality, the appliance's environment, and local sanitation regulations.

| Maintenance Schedule | | |
|----------------------|--------------------|---|
| Frequency | Area | Task |
| Daily | Scoop | Clean the ice scoop using a neutral cleaner. Rinse thoroughly after cleaning. |
| Bi-Weekly | Air Filters | Inspect. Wash with warm water and neutral cleaner if dirty. |
| | Appliance Exterior | Wipe down with a clean, soft cloth. Use a damp cloth containing a neutral cleaner to wipe off oil or dirt build up. Clean any chlorine staining (rust colored spots) using a non-abrasive cleanser. |

B. Service Maintenance Schedule

The service maintenance schedule below is a guideline; service maintenance items are to be performed by qualified service technicians only. More frequent maintenance may be required depending on water quality, the appliance's environment, and local sanitation regulations.

| Maintenance Schedule | | |
|----------------------------|---|---|
| Frequency | Area | Task |
| Monthly | External Water Filters | Check for proper pressure and change if necessary. |
| | Icemaker Exterior | Wipe down with a clean, soft cloth. Use a damp cloth containing a neutral cleaner to wipe off oil or dirt build up. Clean any chlorine staining (rust colored spots) using a non-abrasive cleanser. |
| Every 6 Months | Icemaker and Ice Storage Bin | Clean and sanitize per the cleaning and sanitizing instructions provided in the instruction manual or on maintenance label. |
| | Evaporator Condensate Drain Pan and Gear Motor Drain Pan | Wipe down with a clean cloth and warm water. Slowly pour one cup of sanitizing solution (prepare as outlined in the sanitizing instructions provided in the instruction manual) into the evaporator condensate drain pan and then slowly pour one cup into the gear motor drain pan. Be careful not to overflow the pans. Repeat with a cup of clean water to rinse. |
| | Icemaker and Ice Storage Bin Drains | Check to make sure they are clear. |
| | Extruding Head Seal Bolts | Inspect for leakage around seal bolts. Tighten (see torque values below) or replace as necessary. Seal bolts must be replaced once removed because seal material is one-time use only. If new seal bolts do not have preapplied threadlocker, apply Loctite 243 or equivalent threadlocker to seal bolt threads. • <i>Torque for F-330BAK(-C):</i> 11.1 ft-lb/15 N·m. Tighten 2 times. Allow at least 5 sec. in between each tightening. |
| Yearly | Inlet Water Valve and Drain Valve | Close the water supply line shut-off valve and drain the water system. Clean the inlet water valve screen and clean and inspect the drain valve. |
| | Water Hoses | Inspect the water hoses and clean/replace if necessary. |
| | Condenser | Inspect. Clean if necessary by using a brush or vacuum cleaner. |
| | Icemaker | Inspect for oil spots, loose components, fasteners, and wires. |
| | Upper Bearing (extruding head) | Check for wear using .02" round stock or pin gauge. Replace both upper bearing and lower bearing if wear exceeds factory recommendations. |
| After 3 Years, then Yearly | Upper Bearing (extruding head); Lower Bearing and O-Ring (lower housing); Mechanical Seal; Evaporator Cylinder; Auger | Inspect. Replace both upper bearing and lower bearing if wear exceeds factory recommendations. Replace the mechanical seal if the seal's contact surfaces are worn, cracked, or scratched. |

V. Preparing the Appliance for Periods of Non-Use

| |
|------------------|
| ⚠ WARNING |
|------------------|

| |
|---|
| Only qualified service technicians should service this appliance. |
|---|

| |
|---------------|
| NOTICE |
|---------------|

- | |
|---|
| <ul style="list-style-type: none">• During extended periods of non-use, extended absences, or in sub-freezing temperatures, follow the instructions below to reduce the risk of costly water damage.• When the appliance is not used for two or three days under normal conditions, it is sufficient to move the control switch to the "OFF" position.• To prevent damage to the water pump seal, do not leave the control switch in the "WASH" position for extended periods when the water tank is empty. |
|---|

- 1) Move the control switch to the "OFF" position. **WARNING! To reduce the risk of electric shock, do not touch the control switch or plug with damp hands.**
- 2) Close the water supply line shut-off valve, then open the water supply line drain valve.
- 3) Allow the line to drain by gravity.
- 4) Move the control switch to the "DRAIN" position.
- 5) Allow the water system to drain for 1 min.
- 6) Attach a compressed air or carbon dioxide supply to the water supply line drain valve.
- 7) Move the control switch to the "ICE" position.
- 8) Blow the water supply line out using the compressed air or carbon dioxide supply.
- 9) Close the water supply line drain valve.
- 10) Move the control switch to the "OFF" position, then unplug the appliance from the electrical outlet.
- 11) Remove the screws securing the rear panel, then remove it. See Fig. 3.
- 12) Remove the clamp securing the reservoir outlet hose to the reservoir. Disconnect the reservoir outlet hose from the reservoir.
- 13) Attach a compressed air or carbon dioxide supply to the reservoir outlet hose.
- 14) Plug the appliance back in, then move the control switch to the "DRAIN" position.
- 15) Blow out the reservoir outlet hose using the compressed air or carbon dioxide supply.
- 16) Move the control switch to the "OFF" position, then unplug the appliance from the electrical outlet.
- 17) Reconnect the reservoir outlet hose to the reservoir, then secure with the clamp. Make sure all hoses are connected and secure.
- 18) Replace the rear panel in its correct position.
- 19) Clean the storage bin by using a neutral cleaner. Rinse thoroughly after cleaning.

VI. Decommissioning and Disposal



R-290 Class A3 Flammable Refrigerant Used

⚠ DANGER

Risk of Fire or Explosion. Flammable Refrigerant Used.

- Be sure to follow all Important Safety Information located at the beginning of this manual and at the beginning of section "III.A. Safety Precautions When Servicing."
- Servicing shall be done by trained service personnel with certified competence in handling flammable refrigerants to minimize the risk of possible ignition due to improper service.
- Follow handling instructions carefully in compliance with national regulations.
- Dispose of properly in accordance with federal or local regulations.
- Do not puncture refrigerant tubing. Risk of fire or explosion due to puncture of refrigerant tubing; follow handling instructions carefully.
- When removing refrigerant from a system, either for servicing or decommissioning, it is recommended good practice that all refrigerants are removed safely.
- When transferring refrigerant into cylinders, ensure that only appropriate refrigerant recovery cylinders are employed. Ensure that the correct number of cylinders for holding the total system charge is available. All cylinders to be used are designated for the recovered refrigerant and labeled for that refrigerant (i.e., special cylinders for the recovery of refrigerant). Cylinders shall be complete with pressure-relief valve and associated shut-off valves in good working order. Empty recovery cylinders are evacuated and, if possible, cooled before recovery occurs.
- The recovery equipment shall be in good working order with a set of instructions concerning the equipment that is at hand and shall be suitable for the recovery of all appropriate refrigerants including, when applicable, flammable refrigerants. In addition, a set of calibrated weighing scales shall be available and in good working order. Hoses shall be complete with leak-free disconnect couplings and in good condition. Before using the recovery machine, check that it is in satisfactory working order, has been properly maintained and that any associated electrical components are sealed to prevent ignition in the event of a refrigerant release. Consult manufacturer if in doubt.
- The recovered refrigerant shall be returned to the refrigerant supplier in the correct recovery cylinder, and the relevant waste transfer note arranged. Do not mix refrigerants in recovery units and especially not in cylinders.
- If compressors or compressor oils are to be removed, ensure that they have been evacuated to an acceptable level to make certain that flammable refrigerant does not remain within the lubricant. The evacuation process shall be carried out prior to returning the compressor to the suppliers. Only electric heating to the compressor body shall be employed to accelerate this process. When oil is drained from a system, it shall be carried out safely.

⚠ DANGER Continué

Risque D'Incendie ou D'Explosion. Fluide Frigorigène Inflammable Utilisé.

- Assurez-vous de suivre toutes les informations importantes de sécurité qui se trouvent au début du présent manuel et au début de la section «III.A. Précautions de sécurité lors de l'entretien.»
- L'entretien doit être effectué par du personnel formé et certifié pour la manipulation de réfrigérants inflammables afin de réduire au minimum le risque d'inflammation dû à un entretien inadéquat.
- Suivre attentivement les instructions de manutention conformément aux règlements nationaux.
- Mettre au rebut conformément aux conformément aux règlements fédéraux ou locaux.
- Ne pas perforer la conduite de fluide frigorigène. Risque d'incendie ou d'explosion en cas de perforation d'une canalisation de fluide frigorigène; suivez attentivement les instructions de manutention.
- Lors de l'élimination du réfrigérant d'un système, que ce soit pour l'entretien ou la mise hors service, il est recommandé de veiller à ce que tous les réfrigérants soient éliminés en toute sécurité.
- Lors du transfert de réfrigérant dans des bouteilles, veillez à ce que seules des bouteilles de récupération de réfrigérant appropriées soient utilisées. Assurez-vous que le nombre de bouteilles nécessaires pour contenir la charge totale du système est disponible. Toutes les bouteilles à utiliser sont désignées pour le réfrigérant récupéré et étiquetées pour ce réfrigérant (c'est-à-dire des bouteilles spéciales pour la récupération du réfrigérant). Les bouteilles doivent être équipées d'une soupape de surpression et de soupapes d'arrêt associées en bon état de fonctionnement. Les bouteilles de récupération vides sont évacuées et, si possible, refroidies avant la récupération.
- L'équipement de récupération doit être en bon état de fonctionnement, accompagné d'un ensemble d'instructions concernant l'équipement disponible et doit être adapté à la récupération de tous les réfrigérants appropriés, y compris, le cas échéant, les réfrigérants inflammables. En outre, un ensemble de balances étalonnées doit être disponible et en bon état de fonctionnement. Les tuyaux doivent être complets, équipés de raccords de déconnexion sans fuite et en bon état. Avant d'utiliser la machine de récupération, vérifiez qu'elle est en bon état de fonctionnement, qu'elle a été correctement entretenue et que tous les composants électriques associés sont scellés pour éviter toute inflammation en cas de fuite de réfrigérant. Consulter le fabricant en cas de doute.
- Le réfrigérant récupéré doit être renvoyé au fournisseur de réfrigérant dans la bouteille de récupération appropriée et le bon de transfert de déchets correspondant doit être établi. Ne mélangez pas les réfrigérants dans les unités de récupération et surtout pas dans les bouteilles.

DANGER Continué

- Si les compresseurs ou les huiles de compresseur doivent être retirés, assurez-vous qu'ils ont été évacués à un niveau acceptable afin de s'assurer qu'il ne reste pas de réfrigérant inflammable dans le lubrifiant. Le processus d'évacuation doit être effectué avant que le compresseur ne soit renvoyé aux fournisseurs. Seul le chauffage électrique du boîtier du compresseur doit être utilisé pour accélérer ce processus. Lorsque l'huile est vidangée d'un système, cette opération doit être effectuée en toute sécurité.

The appliance contains refrigerant and must be disposed of in accordance with applicable national, state, and local codes and regulations. Refrigerant must be recovered and safely disposed of by properly trained service personnel.

Before carrying out this procedure, it is essential that the technician is completely familiar with the equipment and all its detail. It is recommended good practice that all refrigerants are recovered safely. Prior to the task being carried out, an oil and refrigerant sample shall be taken in case analysis is required prior to re-use of recovered refrigerant. It is essential that electrical power is available before the task is commenced.

- Become familiar with the equipment and its operation.
- Isolate the system electrically.
- **Before attempting the procedure, ensure that:**
 - mechanical handling equipment is available, if required, for handling refrigerant cylinders
 - all personal protective equipment is available and being used correctly
 - the recovery process is supervised at all times by a competent person
 - recovery equipment and cylinders conform to the appropriate standards
- Pump down refrigerant system, if possible.
- If a vacuum is not possible, make a manifold so that refrigerant can be removed from various parts of the system.
- Make sure that cylinder is situated on the scales before recovery takes place.
- Start the recovery machine and operate in accordance with instructions.
- Do not overfill cylinders (no more than 80% volume liquid charge).
- Do not exceed the maximum working pressure of the cylinder, even temporarily.
- When the cylinders have been filled correctly and the process completed, make sure that the cylinders and the equipment are removed from site promptly and all isolation valves on the equipment are closed off.
- Recovered refrigerant shall not be charged into another refrigerating system unless it has been cleaned and checked.

Follow the steps below for decommissioning and disposal:

1. Recovery

- 1) Recover the refrigerant, and safely dispose of the refrigerant.
- 2) Evacuate the appliance.
- 3) Purge the refrigeration system with nitrogen.
- 4) Cut out the compressor and drain and dispose of the compressor oil. Compressor oils are to be removed, ensure that they have been evacuated to an acceptable level to make certain that flammable refrigerant does not remain within the lubricant. Dispose of compressor and compressor oil in compliance with national, state, and local codes and regulations.
- 5) Purge the refrigeration system with nitrogen.

2. Labeling

Equipment shall be labeled stating that it has been de-commissioned and emptied of refrigerant. The label shall be dated and signed. For appliances containing flammable refrigerant, ensure that there are labels on the equipment stating the equipment contains flammable refrigerant.

VII. Technical Information

We reserve the right to make changes in specifications and design without prior notice.

A. Specification & Performance Data Sheets

Note: The data in bold should be used for reference.

1. F-330BAK

Specification Sheet

| | | |
|---|----------------------------------|---------------|
| AC SUPPLY VOLTAGE (V/Hz/PH) | 115/60/1 | |
| AMPERAGE (A) | 6.3 | |
| MINIMUM CIRCUIT AMPACITY (A) | 15 | |
| MAXIMUM FUSE SIZE (A) | 15 | |
| ELECTRIC & WATER CONSUMPTION (Wtr/Air)(°C/°F) | 32/21 (90/70) | 21/10 (70/50) |
| ELECTRIC W (kWH/100 lbs.) | 480 (4.29) | 440 (3.23) |
| WATER gal./24HR (gal./100 lbs.) | 32.9 (12.0) | 39.7 (12.0) |
| SHAPE OF ICE | Flake | |
| ICE HARDNESS | Approx. 75%, Ice (32/21 (90/70)) | |
| HARVEST RATE (lbs/day) | <=1200 | |
| APPROXIMATE STORAGE CAPACITY (lbs/kg) | 80 (36.3) | |
| ICE MAKING SYSTEM | Auger Type | |
| HARVESTING CONTROL SYSTEM | Direct Drive Auger | |
| ICE MAKING WATER CONTROL | Float Switch | |
| BIN CONTROL SYSTEM | Mechanical (Proximity Switch) | |
| REFRIGERANT CHARGE (g/oz.) | R290 78 (2.8) | |
| FOAM BLOWING AGENT | HFO 1233zd (E) | |
| DESIGN PRESSURE kPa (PSI) | HI-2730 (396) LO-1310 (190) | |

Performance Data Sheet

| APPROXIMATE ICE PRODUCTION PER 24 HR. | AMBIENT TEMP. (°F/°C) | WATER TEMP. (°F/°C) | | | | | |
|---|---|---------------------|-------------|------------|-------------|------------|-------------|
| | | 50/10 | | 70/21 | | 90/32 | |
| | 70/21 | 331 | <u>150</u> | 324 | <u>147</u> | 315 | <u>143</u> |
| | 80/27 | 306 | <u>139</u> | 298 | <u>135</u> | 289 | <u>131</u> |
| | 90/32 | 281 | <u>128</u> | 275 | <u>125</u> | 266 | <u>121</u> |
| lbs./day (kg./day) | 100/38 | 258 | <u>117</u> | 251 | <u>114</u> | 242 | <u>110</u> |
| APPROXIMATE ELECTRIC CONSUMPTION watts | 70/21 | 445 | | 452 | | 460 | |
| | 80/27 | 467 | | 475 | | 482 | |
| | 90/32 | 490 | | 497 | | 505 | |
| | 100/38 | 512 | | 520 | | 527 | |
| APPROXIMATE WATER CONSUMPTION PER 24 HR. gal./day (m ³ /day) | 70/21 | 40 | <u>150</u> | 39 | <u>147</u> | 38 | <u>143</u> |
| | 80/27 | 37 | <u>139</u> | 36 | <u>135</u> | 35 | <u>131</u> |
| | 90/32 | 34 | <u>128</u> | 33 | <u>125</u> | 32 | <u>121</u> |
| | 100/38 | 31 | <u>117</u> | 30 | <u>114</u> | 29 | <u>110</u> |
| EVAPORATOR OUTLET TEMP. °F (°C) | 70/21 | 28 | <u>-2</u> | 28 | <u>-2</u> | 27 | <u>-3</u> |
| | 80/27 | 27 | <u>-3</u> | 26 | <u>-3</u> | 26 | <u>-3</u> |
| | 90/32 | 26 | <u>-4</u> | 25 | <u>-4</u> | 24 | <u>-4</u> |
| | 100/38 | 23 | <u>-5</u> | 22 | <u>-6</u> | 21 | <u>-6</u> |
| HEAD PRESSURE PSIG (kg/cm ² G) | 70/21 | 165 | <u>11.6</u> | 173 | <u>12.1</u> | 181 | <u>12.7</u> |
| | 80/27 | 189 | <u>13.3</u> | 197 | <u>13.8</u> | 205 | <u>14.4</u> |
| | 90/32 | 213 | <u>14.9</u> | 221 | <u>15.5</u> | 229 | <u>16.1</u> |
| | 100/38 | 237 | <u>16.6</u> | 244 | <u>17.2</u> | 252 | <u>17.7</u> |
| SUCTION PRESSURE PSIG (kg/cm ² G) | 70/21 | 26 | <u>1.8</u> | 26 | <u>1.9</u> | 27 | <u>1.9</u> |
| | 80/27 | 28 | <u>2.0</u> | 29 | <u>2.0</u> | 29 | <u>2.1</u> |
| | 90/32 | 30 | <u>2.1</u> | 31 | <u>2.2</u> | 32 | <u>2.2</u> |
| | 100/38 | 32 | <u>2.3</u> | 33 | <u>2.3</u> | 34 | <u>2.4</u> |
| TOTAL HEAT OF REJECTION FROM CONDENSER | 2,900 BTU/h [AT 90°F (32°C) / WT 70°F (21°C)] | | | | | | |
| TOTAL HEAT OF REJECTION FROM COMPRESSOR | 500 BTU/h [AT 90°F (32°C) / WT 70°F (21°C)] | | | | | | |

2. F-330BAK-C

Specification Sheet

| | | |
|---|----------------------------------|---------------|
| AC SUPPLY VOLTAGE (V/Hz/PH) | 115/60/1 | |
| AMPERAGE (A) | 6.3 | |
| MINIMUM CIRCUIT AMPACITY (A) | 15 | |
| MAXIMUM FUSE SIZE (A) | 15 | |
| ELECTRIC & WATER CONSUMPTION (Wtr/Air)(°C/°F) | 32/21 (90/70) | 21/10 (70/50) |
| ELECTRIC W (kWH/100 lbs.) | 500 (5.00) | 470 (3.72) |
| WATER gal./24HR (gal./100 lbs.) | 30 (12.0) | 36 (12.0) |
| SHAPE OF ICE | Cubelet | |
| ICE HARDNESS | Approx. 80%, Ice (32/21 (90/70)) | |
| HARVEST RATE (lbs/day) | <=1200 | |
| APPROXIMATE STORAGE CAPACITY (lbs/kg) | 80 (36.3) | |
| ICE MAKING SYSTEM | Auger Type | |
| HARVESTING CONTROL SYSTEM | Direct Drive Auger | |
| ICE MAKING WATER CONTROL | Float Switch | |
| BIN CONTROL SYSTEM | Mechanical (Proximity Switch) | |
| REFRIGERANT CHARGE (g/oz.) | R290 78 (2.8) | |
| FOAM BLOWING AGENT | HFO 1233zd (E) | |
| DESIGN PRESSURE kPa (PSI) | HI-2730 (396) LO-1310 (190) | |

Performance Data Sheet

| APPROXIMATE ICE PRODUCTION PER 24 HR. | AMBIENT TEMP. (°F/°C) | WATER TEMP. (°F/°C) | | | | | |
|---|---|---------------------|-------------|------------|-------------|------------|-------------|
| | | 50/10 | | 70/21 | | 90/32 | |
| | 70/21 | 300 | <u>136</u> | 296 | <u>134</u> | 287 | <u>130</u> |
| | 80/27 | 278 | <u>126</u> | 269 | <u>122</u> | 261 | <u>118</u> |
| | 90/32 | 253 | <u>115</u> | 250 | <u>113</u> | 238 | <u>108</u> |
| lbs./day (kg./day) | 100/38 | 230 | <u>105</u> | 223 | <u>101</u> | 211 | <u>96</u> |
| APPROXIMATE ELECTRIC CONSUMPTION | 70/21 | 465 | | 473 | | 481 | |
| | 80/27 | 489 | | 497 | | 505 | |
| | 90/32 | 512 | | 520 | | 527 | |
| watts | 100/38 | 534 | | 540 | | 547 | |
| APPROXIMATE WATER CONSUMPTION PER 24 HR. | 70/21 | 36 | <u>136</u> | 35 | <u>134</u> | 34 | <u>130</u> |
| | 80/27 | 33 | <u>126</u> | 32 | <u>122</u> | 31 | <u>118</u> |
| | 90/32 | 30 | <u>115</u> | 30 | <u>113</u> | 28 | <u>108</u> |
| gal./day (m ³ /day) | 100/38 | 28 | <u>104</u> | 27 | <u>101</u> | 25 | <u>96</u> |
| EVAPORATOR OUTLET TEMP. °F (°C) | 70/21 | 30 | <u>-1</u> | 28 | <u>-2</u> | 27 | <u>-3</u> |
| | 80/27 | 26 | <u>-4</u> | 24 | <u>-4</u> | 23 | <u>-5</u> |
| | 90/32 | 22 | <u>-6</u> | 20 | <u>-6</u> | 21 | <u>-6</u> |
| | 100/38 | 21 | <u>-6</u> | 21 | <u>-6</u> | 22 | <u>-6</u> |
| HEAD PRESSURE | 70/21 | 170 | <u>11.9</u> | 177 | <u>12.5</u> | 185 | <u>13.0</u> |
| | 80/27 | 192 | <u>13.5</u> | 200 | <u>14.0</u> | 207 | <u>14.6</u> |
| | 90/32 | 215 | <u>15.1</u> | 222 | <u>15.6</u> | 231 | <u>16.2</u> |
| PSIG (kg/cm ² G) | 100/38 | 239 | <u>16.8</u> | 247 | <u>17.4</u> | 255 | <u>17.9</u> |
| SUCTION PRESSURE | 70/21 | 26 | <u>1.8</u> | 26 | <u>1.8</u> | 27 | <u>1.9</u> |
| | 80/27 | 28 | <u>1.9</u> | 28 | <u>2.0</u> | 29 | <u>2.0</u> |
| | 90/32 | 30 | <u>2.1</u> | 31 | <u>2.2</u> | 31 | <u>2.2</u> |
| PSIG (kg/cm ² G) | 100/38 | 32 | <u>2.3</u> | 33 | <u>2.3</u> | 34 | <u>2.4</u> |
| TOTAL HEAT OF REJECTION FROM CONDENSER | 2,900 BTU/h [AT 90°F (32°C) / WT 70°F (21°C)] | | | | | | |
| TOTAL HEAT OF REJECTION FROM COMPRESSOR | 500 BTU/h [AT 90°F (32°C) / WT 70°F (21°C)] | | | | | | |

B. Wiring Diagram

1. F-330BAK(-C)

| S2 DIP SWITCH SETTING | 1 | 2 | 3 | 4 | 5 | 6 | 7 | 8 | 9 | 10 |
|-----------------------|-----|-----|-----|-----|-----|-----|-----|-----|----|-----|
| F-330BAK/-C | OFF | OFF | OFF | OFF | OFF | OFF | OFF | OFF | ON | OFF |

