

Hoshizaki America, Inc.

Professional Series Refrigerated Kitchen Equipment

Model
SSE



“A Superior Degree
of Reliability”

www.hoshizaki.com

SERVICE MANUAL



Number: 73177
Issued: 4-14-2010
Revised: 9-17-2015

IMPORTANT

Only qualified service technicians should install, service, and maintain the unit. No service or maintenance should be undertaken until the technician has thoroughly read this Service Manual. Failure to service and maintain the equipment in accordance with this manual may adversely affect safety, performance, component life, and warranty coverage.

Hoshizaki provides this manual primarily to assist qualified service technicians in the service and maintenance of the unit.

Should the reader have any questions or concerns which have not been satisfactorily addressed, please call, write, or send an e-mail message to the Hoshizaki Technical Support Department for assistance.

HOSHIZAKI AMERICA, INC.
618 Highway 74 South
Peachtree City, GA 30269

Attn: Hoshizaki Technical Support Department

Phone: 1-800-233-1940 Technical Support
(770) 487-2331
Fax: 1-800-843-1056
(770) 487-3360
E-mail: techsupport@hoshizaki.com

Web Site: www.hoshizaki.com

NOTE: To expedite assistance, all correspondence/communication MUST include the following information:

- Model Number _____
- Serial Number _____
- Complete and detailed explanation of the problem.

IMPORTANT

This manual should be read carefully before the unit is serviced or maintenance operations are performed. Only qualified service technicians should install, service, and maintain the unit. Read the warnings contained in this booklet carefully as they give important information regarding safety. Please retain this booklet for any further reference that may be necessary.

CONTENTS

Important Safety Information	5
I. General Information	6
A. Construction	6
1. One Section	6
2. Two Section	7
3. Three Section	8
B. Sequence of Operation	9
1. Sequence Cycles and Shutdown	9
a) Startup	9
b) Cool Down	9
c) Cool Down Achieved	9
d) Cool Down Restart	9
e) Defrost	9
2. Sequence Flow Chart	10
C. Display Board	11
D. Control Board	12
1. Control Board Layout	13
2. Features	14
a) LED Display	14
b) Guarded Access Menu	14
c) Service Menu	14
d) Alarm Signals	14
e) Defrost	14
f) Default Safety Program	14
g) High Voltage and Low Voltage Cut-outs	14
3. LED Lights and Alarm Safeties Chart	15
4. Controls and Adjustments	17
a) Default Dip Switch Settings	17
b) Unit Operation (Freezer/Refrigerator) (S3 dip switch 1)	17
c) Cabinet Light/Heated Glass Door (S3 dip switch 2)	18
d) Door Switch Type (S3 dip switch 3)	18
e) Reach-In/Pass Thru Defrost Initiation Temperature (S3 dip switch 4)	18
f) Display Board Operation (S3 dip switch 5)	18
g) Dual Temp Unit (S3 dip switch 6)	19
h) Freezer Evaporator Fan Operation (except RFH1) (S3 dip switch 7)	19
i) RFH1 Condensate Pan Heater Operation (S3 dip switch 8)	19

5. Guarded Access Menu	20
a) Temperature Setpoint.....	20
b) Defrost Frequency.....	20
c) Temperature Display Scale (°F or °C)	21
6. Service Menu	22
E. Compressor Thermal Overload and Short Cycle Protection.....	23
F. Perimeter Heater.....	23
G. Thermistors	23
III. Technical Data	24
A. Wiring Diagrams.....	24
1. RH_-SSE-XX (FG, HG, FS, or HS) Models	24
2. PTR_SSE-XXXX (FSFS, HSHS, FGFG, HGHG, HGHS) Models	25
IV. Service Diagnosis.....	26
A. Diagnostic Procedure	26
B. Control Board Check.....	29
C. Thermistor Check.....	30
D. Diagnostic Chart	31
1. Unit Not Cooling.....	31
2. Evaporator is Frozen Up	33
3. Defrost Fails to Terminate	33
4. Other.....	33
V. Removal and Replacement of Components	34
A. Service for Refrigerant Lines.....	34
1. Refrigerant Recovery	34
2. Brazing	35
3. Evacuation and Recharge (R-134a)	35
B. Removal and Replacement of Compressor.....	36
C. Removal and Replacement of Compressor Electronic Unit	37
D. Removal and Replacement of Expansion Valve.....	38
E. Removal and Replacement of Evaporator.....	39
F. Removal and Replacement of Evaporator Fan Motor	40
G. Removal and Replacement of Door Gasket	40
H. Removal and Replacement of Door Closure Spring	41
I. Door Re-Hinging.....	42
J. Removal and Replacement of Control Board.....	42
K. Removal and Replacement of Thermistors	43
VI. Cleaning Instructions.....	44

Important Safety Information

Throughout this manual, notices appear to bring your attention to situations which could result in death, serious injury, or damage to the unit.

⚠ WARNING Indicates a hazardous situation which could result in death or serious injury.

CAUTION Indicates a situation which could result in damage to the unit.

IMPORTANT Indicates important information about the use and care of the unit.

⚠ WARNING

This unit should be destined only to the use for which it has been expressly conceived. Any other use should be considered improper and therefore dangerous. The manufacturer cannot be held responsible for eventual damage caused by improper, incorrect, and unreasonable use.

To reduce the risk of death, electric shock, serious injury, or fire, follow basic precautions including the following:

- This unit requires an independent power supply. See the nameplate for proper voltage and breaker/fuse size. Failure to use a proper breaker or fuse can result in a tripped breaker, blown fuse, or damage to existing wiring. This could lead to heat generation or fire.
- **THIS UNIT MUST BE GROUNDED:** This unit is equipped with a 3-prong grounding plug to reduce the risk of potential shock hazards. It must be plugged into a properly grounded, independent 3-prong wall outlet. If the outlet is a 2-prong outlet, it is your personal responsibility to have a qualified electrician replace it with a properly grounded, independent 3-prong wall outlet. Do not remove the ground prong from the power cord and do not use an adapter plug.
- Do not use an extension cord.
- Make sure the control switch is in the "OFF" position before plugging in or unplugging the unit to reduce the risk of electric shock.
- Do not use a unit with a damaged power cord. The power cord should not be altered, jerked, bundled, weighed down, pinched, or tangled. Such actions could result in electric shock or fire. To unplug the unit, be sure to pull the plug, not the cord, and do not jerk the cord.
- To reduce the risk of electric shock, do not touch the plug or control switch with damp hands.
- This unit should be disassembled or repaired only by qualified service personnel to reduce the risk of electric shock, injury, or fire.
- Do not make any alterations to the unit. Alterations could result in electric shock, injury, fire, or damage to the unit.

I. General Information

A. Construction

1. One Section

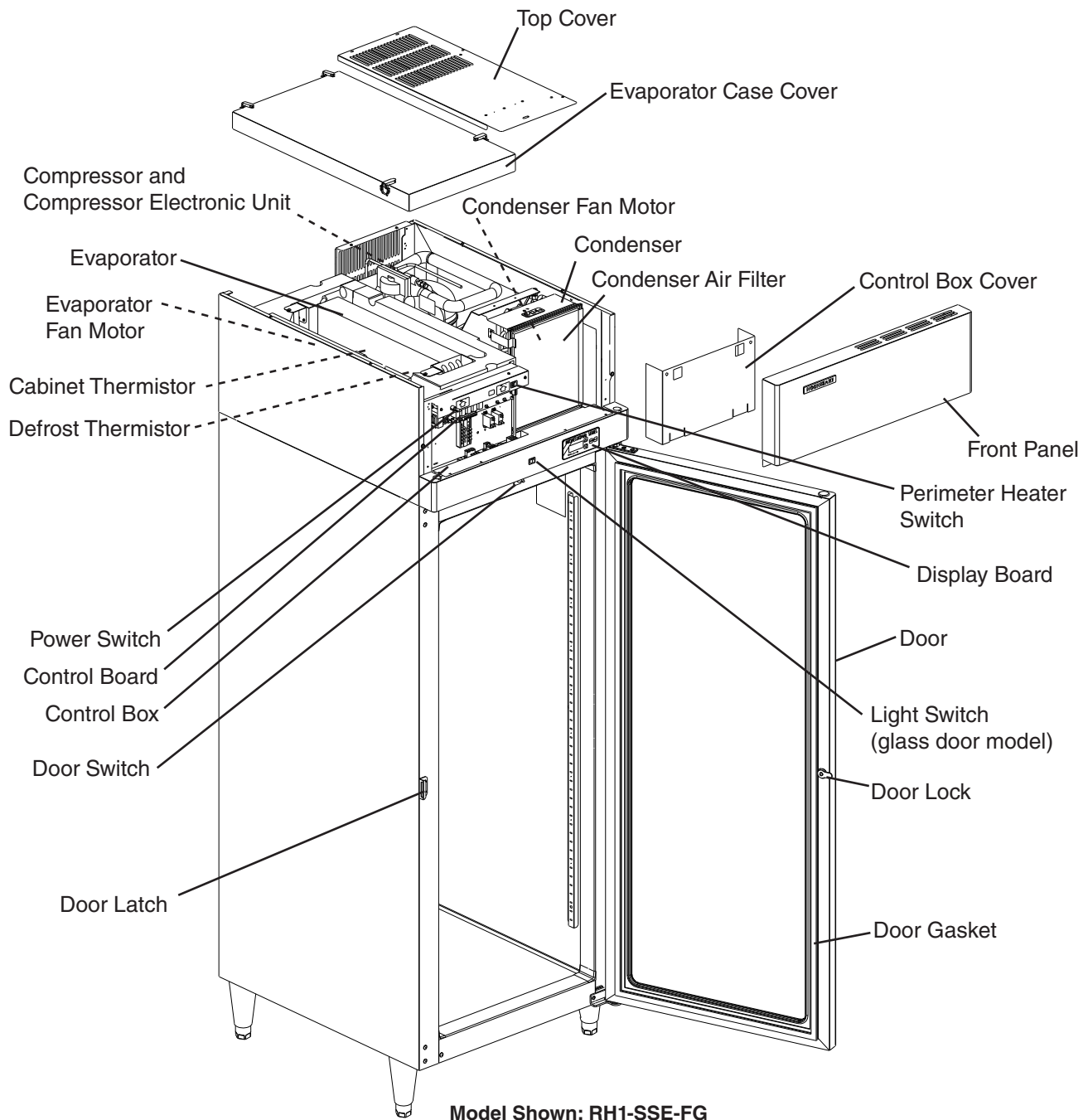

Models
RH1-SSE-FG, RH1-SSE-HG RH1-SSE-FS, RH1-SSE-HS

2. Two Section

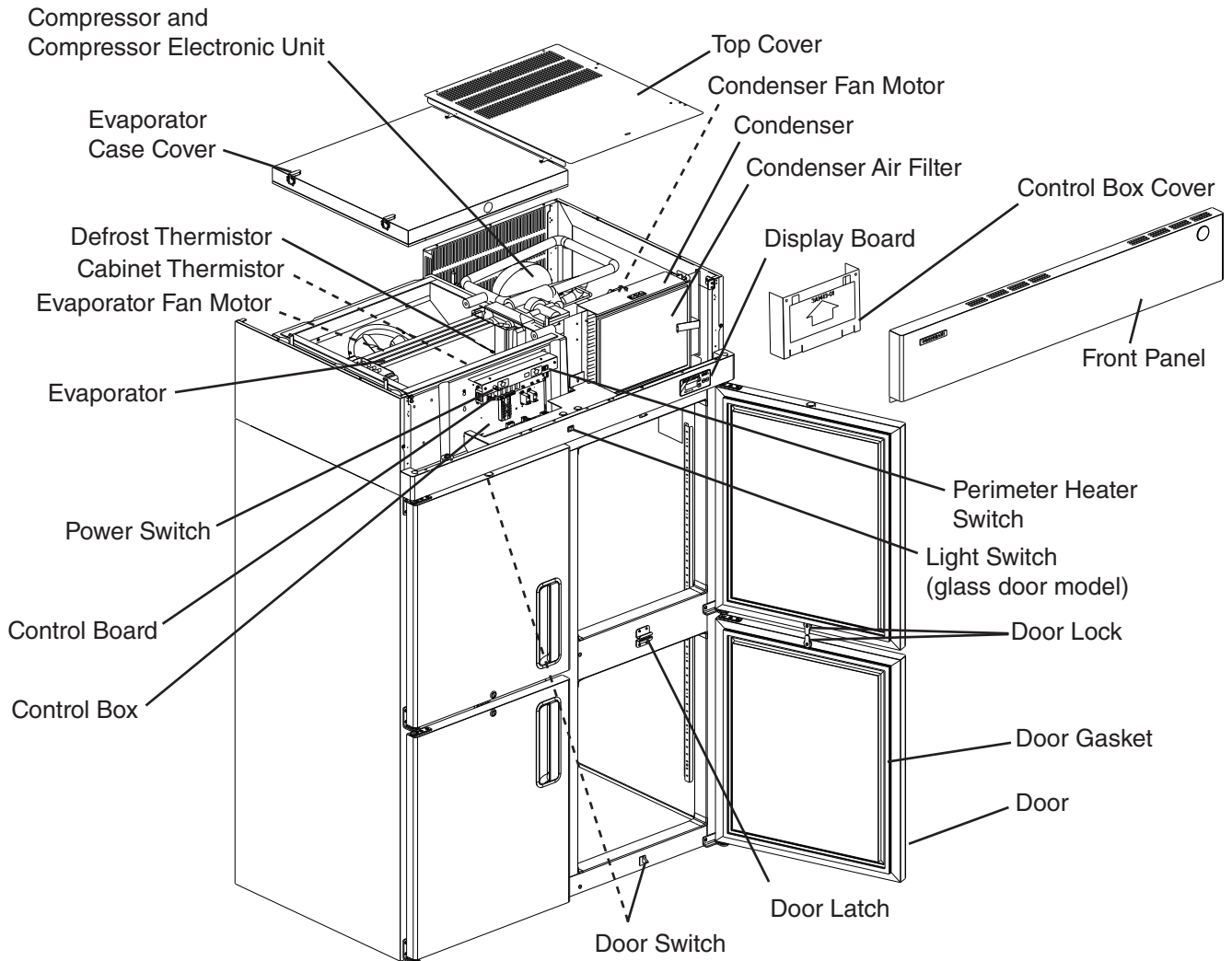

Model Shown: RH2-SSE-HS

Models
RH2-SSE-FG, RH2-SSE-HG
RH2-SSE-FS, RH2-SSE-HS

3. Three Section

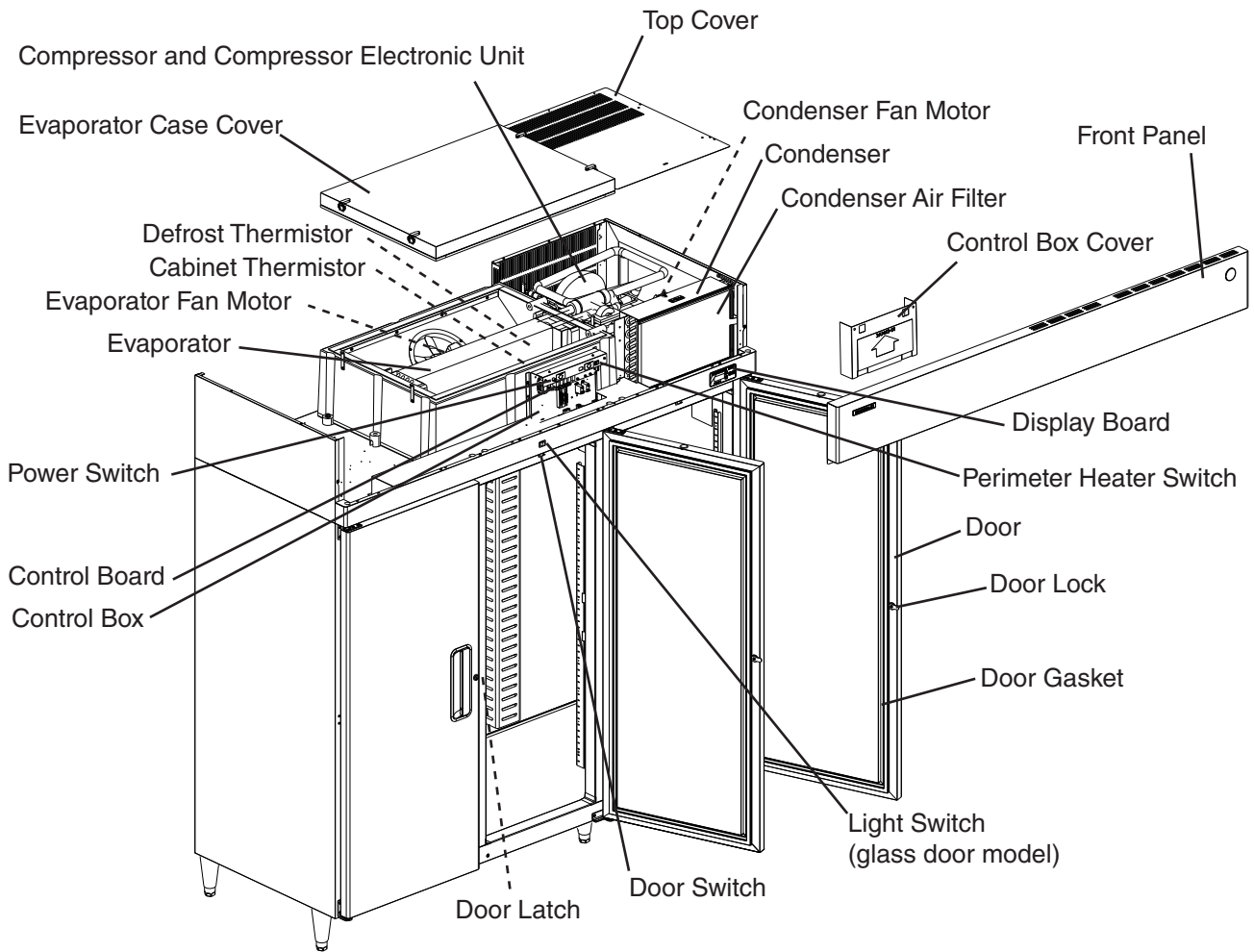

Model Shown: RH3-SSE-FS

Models
RH3-SSE-FG, RH3-SSE-HG
RH3-SSE-FS, RH3-SSE-HS

B. Sequence of Operation

1. Sequence Cycles and Shutdown

The steps in the sequence are as outlined below. This unit utilizes a control board to switch the components on and off as needed. When power is supplied and the power switch is in the "ON" position, CB red "POWER OK" LED comes on and CB revision (r###) appears on DB.

Note: 1. "POWER OK" LED remains on until the power switch is moved to the "OFF" position, the power supply is turned off, or the unit is unplugged from the electrical outlet.

2. There is a minimum 2.5-minute Comp on time and 2.5-minute Comp off time.

a) Startup

No Component LED on: EvapFM energizes. 2.5-minute Comp delay timer starts. Cabinet temperature appears on DB.

b) Cool Down

LEDs 4 and 5 on: 2.5-minute Comp delay timer terminates, EvapFM continues, Comp, ConFM, and PH energize.

c) Cool Down Achieved

No Component LED on: CB monitors cooling of the cabinet via CTh. CTh cools to 3°F (1.7°C) below setpoint. EvapFM continues, Comp, ConFM, and PH de-energize.

d) Cool Down Restart

LEDs 4 and 5 on: CTh warms to 3°F (1.7°C) above setpoint. EvapFM continues, Comp, ConFM, and PH energize.

e) Defrost

LED 5 on:

(1a) Temperature-Initiated Defrost

DTh cools to 13°F (-10°C). Comp and PH, if energized, de-energize, EvapFM continues. If energized, ConFM continues, otherwise, ConFM energizes. Cabinet temperature is displayed on DB during defrost.

(1b) Optional Time-Initiated Defrost

The optional time-initiated defrost is factory set to 0 times per day. Before changing this setting, contact Hoshizaki Technical Support at 1-800-233-1940 for recommendations.

When set to greater than 0, defrost initiates when the defrost timer terminates. For further details, see "II.D.5.b) Defrost Frequency."

(2) Defrost Termination

DTh warms to 40°F (4.4°C). EvapFM and ConFM continue. 2.5 minute delay before Comp and PH energize.

Legend: **CB**—control board; **ConFM**—condenser fan motor; **Comp**—compressor; **CTh**—cabinet thermistor; **DB**—display board; **DTh**—defrost thermistor; **EvapFM**—evaporator fan motor; **PH**—perimeter heater

2. Sequence Flow Chart

Refrigerator Sequence Flow Chart

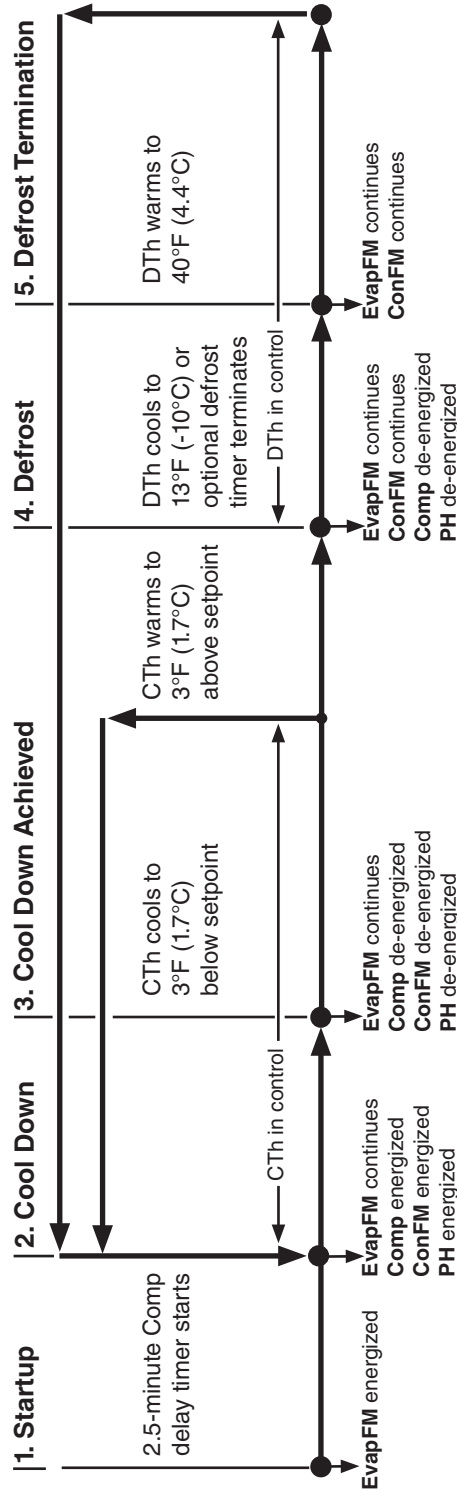

Legend:
 EvapFM-cabinet fan motor
 CTh-cabinet thermistor
 Comp-compressor
 ConFM-condenser fan motor
 DTh-defrost thermistor
 PH-perimeter heater

Note: Minimum 2.5-minute Comp on time and 2.5-minute Comp off time.

C. Display Board

When the power switch is moved to the "ON" position, the control board revision appears on the display board. "r###" indicates the control board revision level (e.g., r23C). Afterward, the current cabinet temperature is displayed. The display board also allows for access to the guarded access menu and service menu. From the guarded access menu, the cabinet setpoint, defrost frequency, and temperature display scale can be adjusted. For further details, see "II.D.5. Guarded Access Menu." From the service menu, information regarding unit functions can be obtained. For further details, see "II.D.6. Service Menu."

Display Board

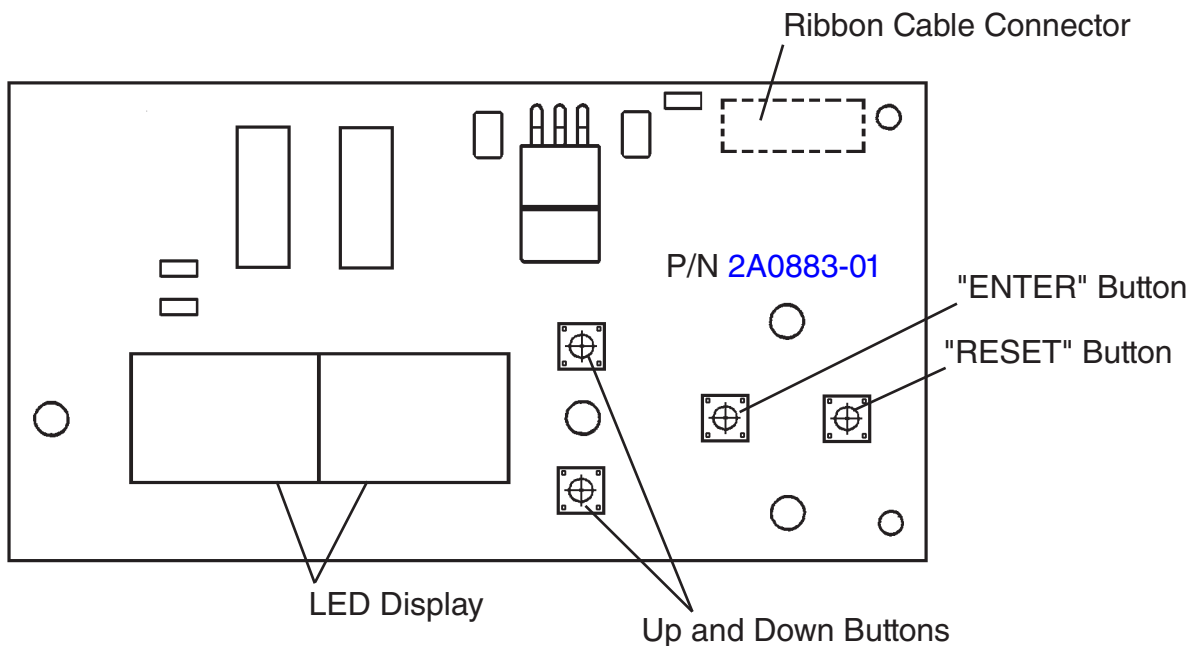
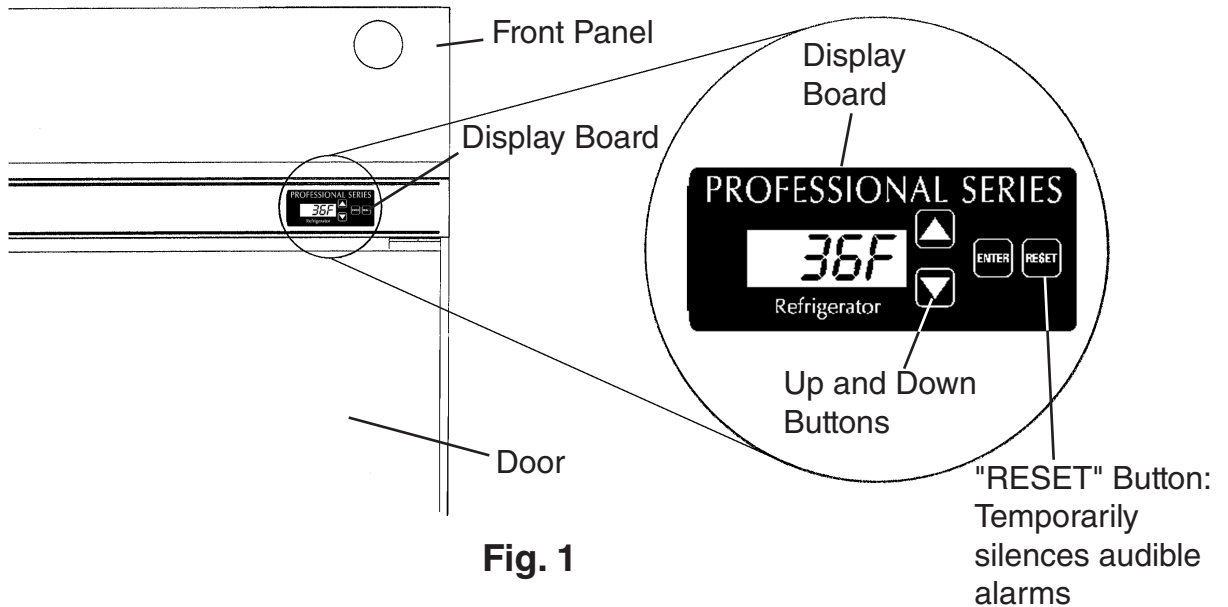

D. Control Board

- A Hoshizaki exclusive control board is employed in all Hoshizaki Professional Series Reach-Ins.
- All models are pretested and factory set.

CAUTION

1. The control board is fragile, handle very carefully.
2. The control board contains integrated circuits, which are susceptible to failure due to static discharge. It is especially important to touch the metal part of the unit before handling or replacing the control board.
3. Do not touch the electronic devices on the control board or the back of the control board.
4. Do not change wiring and connections. Never misconnect terminals.
5. Always replace the whole control board assembly if it goes bad.
6. Do not short out power supply to test for voltage.
7. Keep the thermistor leads, clogged filter thermostat leads, door switch leads, pressure switch leads, and ribbon cable at least 1-1/2" away from high voltage leads (100VAC or more) to protect against electrical noise.

1. Control Board Layout

"R-A" Control Board

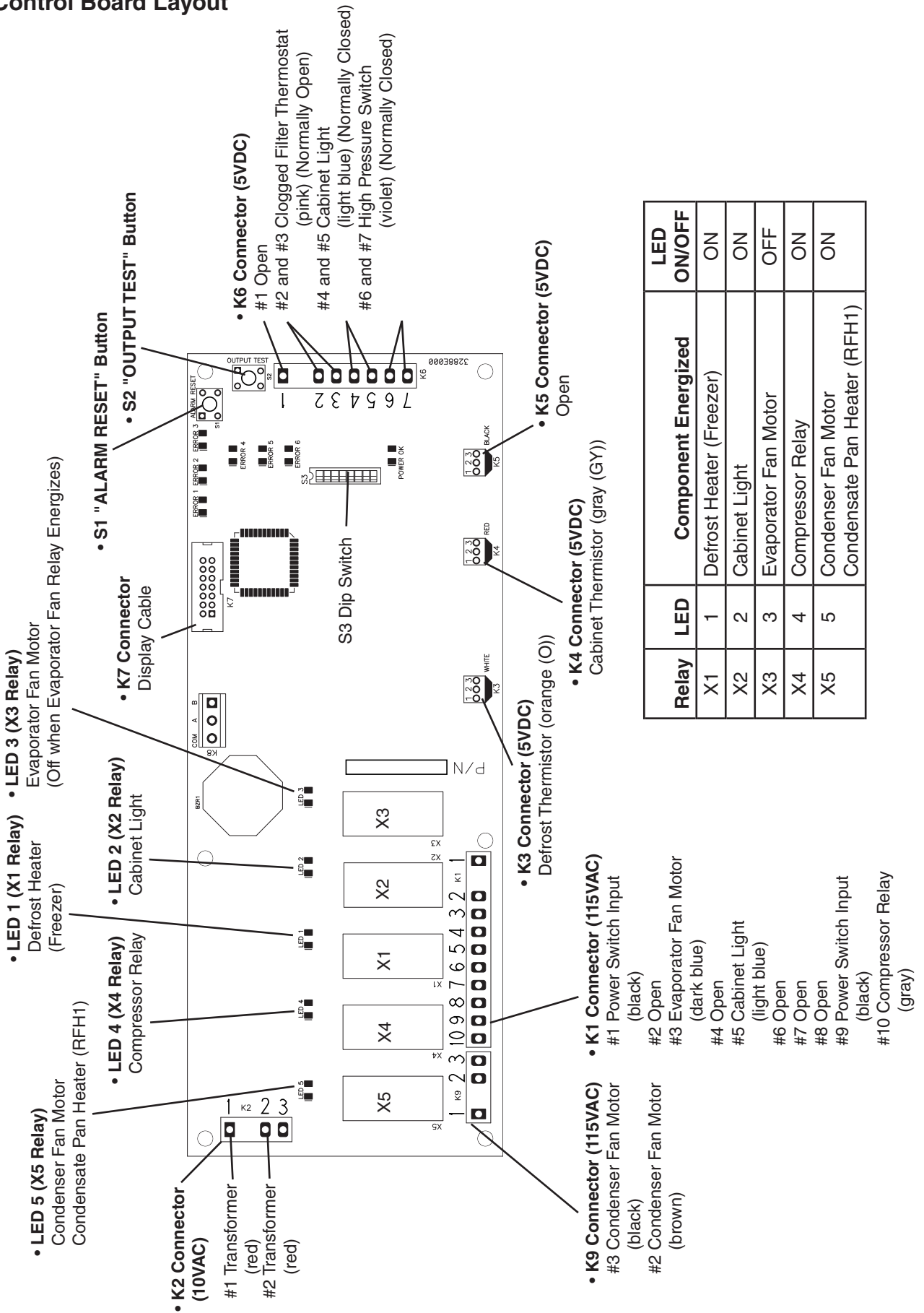

Relay	LED	Component Energized	LED ON/OFF
X1	1	Defrost Heater (Freezer)	ON
X2	2	Cabinet Light	ON
X3	3	Evaporator Fan Motor	OFF
X4	4	Compressor Relay	ON
X5	5	Condensate Pan Heater (RFH1)	ON

2. Features

a) LED Display

The display board identifies system details and diagnostic information. A ribbon cable connects the display board to the control board for system communication. Be sure to keep the ribbon cable at least 1-1/2" away from high voltage leads (100VAC or more) to protect against electrical noise.

b) Guarded Access Menu

Three settings can be viewed and changed from the guarded access menu: Temperature Setpoint, Defrost Frequency, and Temperature Display Scale (°F or °C). For details, see "II.D.5. Guarded Access Menu."

c) Service Menu

The service menu allows for the viewing and setting of system operating details and parameters. For details, see "II.D.6. Service Menu."

d) Alarm Signals

Alarm signals are designed to protect the unit and food product. These alarms give information or warnings in the event the unit is operating out of acceptable parameters. For details, see "II.D.3. LED Lights and Alarm Safeties Chart."

e) Defrost

Main defrost control: Temperature-initiated, temperature-terminated defrost. Optional defrost control: Time-initiated, temperature-terminated defrost. For details, see "II.D.5.b) Defrost Frequency."

f) Default Safety Program

Cabinet Thermistor: In the event the cabinet thermistor reading is out of range, the compressor operates on a fixed time basis of 5-minutes on and 5-minutes off.

Defrost Thermistor: In the event the defrost (evaporator) thermistor reading is out of range, defrost initiation occurs every 6 hours and terminates at 40°F cabinet thermistor temperature.

Cabinet and Defrost Thermistor: In the event both thermistor readings are out of range, the compressor operates on a fixed time basis of 5-minutes on and 5-minutes off and a defrost cycle initiates every 6 hours and terminates after 45 minutes. For further details, see "IV.C. Thermistor Check."

g) High Voltage and Low Voltage Cut-outs

The maximum and minimum allowable supply voltages of this unit are limited by the high and low voltage cut-outs.

If high voltage (140VAC±5% or more) is present, the unit automatically stops and the control board signals with "E6" display and 8-beep alarm every 3 seconds.

If low voltage (92VAC±5% or less) is present, the unit automatically stops and the control board signals with "E7" display and 9-beep alarm every 3 seconds.

When the proper supply voltage is resumed, the unit automatically starts running again.

3. LED Lights and Alarm Safeties Chart

With proper power supply, the "POWER OK" LED energizes and remains on. LEDs 1 through 5 energize as the unit cycles through the sequence of operation. If an error occurs, the alarm code and cabinet temperature are displayed in 2-second intervals and an alarm sounds. To temporarily reset alarm, press the display board "RESET" button. To reset and clear the control board memory of an alarm, press the control board "ALARM RESET" button. See the table below for a description of alarms and reset options.

Sequence Steps	LEDs	Energized Components	Notes
Start	-	EvapFM	LED 3 off when EvapFM energized.
Cool Down	4 and 5	EvapFM, Comp, and ConFM	At startup 2.5 minute Comp delay.
Cool Down Achieved	-	EvapFM	2.5 minute minimum off time.
Defrost	5	EvapFM, ConFM	-
Door Open	2	Cabinet Light (solid door)	-

Alarm Signals			
Alarm Code	No. of Beeps (every 10 sec.)	Problem	Reset Options
E1	3	High Temperature Alarm Cabinet temperature has remained above setpoint by 10°F (5.6°C) for more than 2 hours.	Press the display board "RESET" button. If temperature has returned to setpoint range, alarm stops and "E1" clears. If temperature is not back in range, pressing the display board "RESET" button temporarily silences the alarm for 5 minutes. "E1" continues to flash.
E2	4	Low Temperature Alarm Cabinet temperature has remained below setpoint by 8°F (4.4°C) for more than 1 hour.	Press the display board "RESET" button. If temperature has returned to setpoint range, alarm stops and "E2" clears. If the temperature is not back in range, pressing the display board "RESET" button temporarily silences the alarm for 5 minutes. "E2" continues to flash.
E3	5	N/A [Freezer Only] Defrost longer than 1 hour.	N/A
E4	6	High Pressure Alarm Compressor discharge pressure is outside normal operating range. Pressure switch has been triggered 3 or more times in 1 hour. If switch trips 5 times in 1 hour, compressor stops and will not restart.	After 5 high pressure switch trips, the alarm can be silenced for 1 hour by pressing the display board "RESET" button. Service Tech: Reset by pressing the control board "ALARM RESET" button.
E6	8	High Voltage (140VAC±5% or less)	"POWER OK" LED turns off if voltage protection operates. The voltage safeties automatically reset when voltage is corrected.
E7	9	Low Voltage (90VAC±5% or less)	Press the display board "RESET" button to temporarily silence the alarm for 5 minutes.
E8	Constant	Cabinet Thermistor During alarm, unit operates in cabinet thermistor fail mode. Cabinet Thermistor Fail Mode: Unit on 5 minutes, off 5 minutes. This continues until thermistor is replaced.	After replacing thermistor, alarm resets. During alarm, press the display board "RESET" button to silence alarm for 5 minutes.

Alarm Signals (continued)			
Alarm Code	No. of Beeps (every 10 sec.)	Problem	Reset Options
E9	Constant	Defrost Thermistor During alarm, unit operates in the defrost thermistor fail mode. Defrost Thermistor Fail Mode: Defrost occurs once every 6 hours and terminates after 45 minutes.	After replacing thermistor, alarm resets. During alarm, press the display board "RESET" button to silence alarm for 5 minutes.
E10	10	N/A [Dual Temp Models Only] Communication error between control boards.	N/A
CF	1	Clogged Filter Alarm (condenser thermostat) Condenser filter needs cleaning. WARNING: If this alarm occurs frequently, discharge temperature is consistently too high. Failure to take action could result in damage to the compressor.	Clean filter. Allow time for thermostat to react, then press the display board "RESET" button. During alarm, press the display board "RESET" button to silence alarm for 2 hours.
door	2	Door open: Display alternates between cabinet temperature and "door." Door open longer than 3 minutes: alternating display continues and alarm sounds.	Close door. During alarm, press the display board "RESET" button to temporarily silence alarm for 3 minutes.

Note: Setting service menu item #3 to "ON" resets all alarms regardless of whether or not the problems are resolved. This is a complete clearing of all alarms. See "II.D.6. Service Menu" for details.

4. Controls and Adjustments

CAUTION

Dip switches are factory set. Failure to maintain factory settings may adversely affect performance and warranty coverage. For more information, contact Hoshizaki Technical Support at 1-800-233-1940.

a) Default Dip Switch Settings

The S3 dip switch settings are factory-set to the following positions:

S3 Dip Switch								
Dip Switch No.	1	2	3	4	5	6	7	8
All SSE Models	ON	OFF	OFF	OFF	OFF	OFF	OFF	OFF

S3 Dip Switch

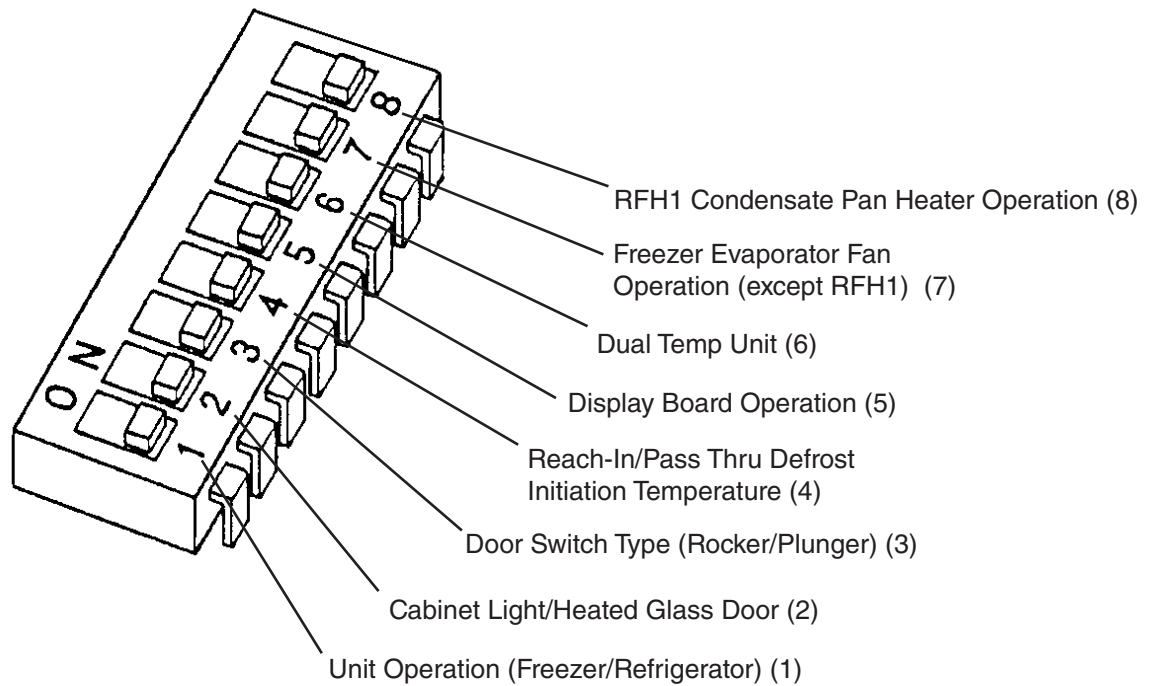

b) Unit Operation (Freezer/Refrigerator) (S3 dip switch 1)

This setting determines whether the control board operates in refrigerator mode or freezer mode. It also determines the temperature setpoint range at which the unit operates.

Factory set, no adjustment required.

S3 Dip Switch Setting	Unit Operation	Temperature Setpoint Range	Factory Default
No. 1			
OFF	Freezer	-10°F (-23°C) to 25°F (-3.9°C)	-3°F (-19.4°C)
ON	Refrigerator	36°F (2.2°C) to 50°F (10°C)	36°F (2.2°C)

c) Cabinet Light/Heated Glass Door (S3 dip switch 2)

When the cabinet light option is selected (S3 dip switch 2 "OFF"), the control board energizes the K1 connector pin #5 light blue (LBU) wire and turns on the cabinet light (solid door models) each time the door and door switch open.

When the heated glass door option is selected (S3 dip switch 2 "ON"), the control board energizes the K1 connector pin #5 when the compressor is off, and de-energizes when the compressor turns on. Professional Series SSE glass doors are not heated.

Factory set, no adjustment required. Do not adjust to "ON" position on SSE models.

S3 Dip Switch Setting	Cabinet Light/Heated Glass Door
No. 2	
OFF	Cabinet Light (Solid Door)
ON	Heated Glass Door (No Longer Applicable)

d) Door Switch Type (S3 dip switch 3)

Hoshizaki has utilized both normally open and normally closed door switch contact styles. S3 dip switch 3 is used to select the type of switch used on a particular model. Factory set, no adjustment required.

S3 Dip Switch Setting	Door Switch Type (Rocker or Plunger)
No. 3	
OFF	Rocker Door Switch (square): Open Contacts when Doors are Open
ON	Plunger Door Switch (round): Closed Contacts when Doors are Open

e) Reach-In/Pass Thru Defrost Initiation Temperature (S3 dip switch 4)

Refrigerators only. Pass Thru refrigerator models require a defrost initiation temperature that is different from the reach-in refrigerator models.

Factory set, no adjustment required.

S3 Dip Switch Setting	Model	Defrost Initiation Temperature
No. 4		
OFF	All Refrigerators Except Pass Thru	13°F (-10.5°C)
ON	Pass Thru	8°F (-13.3°C)

f) Display Board Operation (S3 dip switch 5)

The display board may be disabled by moving S3 dip switch 5 to the "ON" position. When the display board is disabled, the control board operates in default mode.

Default Mode: Compressor on 5-minutes then off 5-minutes. See "II.D.2.f) Default Safety Program."

Factory set, no adjustment required.

S3 Dip Switch Setting	Display Board Status
No. 5	
OFF	Enabled
ON	Disabled

g) Dual Temp Unit (S3 dip switch 6)

Dual Temp units require S3 dip switch 6 be placed in the "ON" position for proper operation. **CAUTION! Do not adjust S3 dip switch 6 out of the factory default position on this model. This dip switch must be left in the factory default position or this unit will not operate correctly.** Factory set, no adjustment required.

S3 Dip Switch Setting	Dual Temp Selector Switch
No. 6	
OFF	All Models Except Dual Temp
ON	Dual Temp Models

h) Freezer Evaporator Fan Operation (except RFH1) (S3 dip switch 7)

Active when S3 dip switch 1 and S3 dip switch 8 are in the "OFF" position (freezer application). When S3 dip switch 7 is in the "ON" position, evaporator fan operates continuously (except during defrost) and the temperature at which the evaporator fan resumes after defrost changes from 0°F (-17.7°C) to 70°F (21°C). When set to the "OFF" position, the evaporator fan cycles on and off with the compressor. After defrost, evaporator fan resumes when evaporator temperature reaches 0°F (-17.7°C).

Factory set, no adjustment required.

Note: S3 dip switch 7 is ignored when S3 dip switch 1 or S3 dip switch 8 is in the "ON" position.

S3 Dip Switch Setting	Freezer Evaporator Fan Operation
No. 7	
OFF	Evap. Fan Cycles On and Off with the Compressor After Defrost, Evap. Fan Restarts when Defrost Thermistor Reaches 0°F (-17.7°C)
ON	Continuous Evap. Fan (except during defrost) After Defrost, Evap. Fan Restarts when Defrost Thermistor Reaches 70°F (21°C)

i) RFH1 Condensate Pan Heater Operation (S3 dip switch 8)

Active when S3 dip switch 1 is in the "OFF" position (freezer application) and S3 dip switch 6 is in the "ON" position (Dual Temp application). When S3 dip switch 8 is in the "OFF" position, the condensate pan heater is not active and the evaporator fan cycles according to S3 dip switch 7 setting. When S3 dip switch 8 is in the "ON" position, the control board energizes the condensate pan heater through the control board X5 relay (on when compressor is off) and the evaporator fan runs continuously (except in defrost).

CAUTION! Do not adjust S3 dip switch 8 out of the factory default position on this model. This dip switch must be left in the factory default position or this unit will not operate correctly. Factory set, no adjustment required.

Note: S3 dip switch 8 is ignored when S3 dip switch 1 is in the "ON" position or S3 dip switch 6 is in the "OFF" position.

S3 Dip Switch Setting	RFH1 Condensate Pan Heater Operation
No. 8	
OFF	X5 Relay Controls Condenser Fan Motor Evap. Fan Defaults to S3 Dip Switch 7 Setting
ON	X5 Relay Controls Condensate Pan Heater Continuous Evap. Fan (except during defrost) After Defrost, Evap. Fan Restarts when Defrost Thermistor Reaches 0°F (-17.7°C)

5. Guarded Access Menu

Three settings can be viewed and adjusted from this menu: temperature setpoint, defrost frequency, and temperature display scale. To enter the guarded access menu, press and hold the up and down buttons simultaneously for 3 seconds. The current setpoint temperature is displayed.

a) *Temperature Setpoint*

The temperature setpoint is the value for the average cabinet temperature. The temperature differential for the compressor to turn on and off is $\pm 3^{\circ}\text{F}$ of the setpoint. For example, setpoint = 36°F (2.2°C), compressor on at 39°F (3.9°C), compressor off at 33°F (0.6°C). If necessary, adjust the setpoint temperature as follows:

- 1) Press and hold the up and down buttons simultaneously for 3 seconds. The current setpoint temperature is displayed.
- 2) To change the setpoint, press the up or down button until the desired value appears. The cabinet temperature is adjustable between 36°F and 50°F (2.2°C and 10°C). Factory default is 36°F (2.2°C).
- 3) Press the "ENTER" button to set the value and view the next setting. If no change in value is desired, press the "ENTER" button repeatedly until you return to the normal display. If you do not cycle through the menu and no button is pressed in 15 seconds, the display returns to normal and the temperature setpoint remains unchanged.

b) *Defrost Frequency*

This unit uses an off-cycle defrost initiated by temperature or time. During defrost the cabinet temperature is displayed and the condenser fan motor and evaporator fan motor are energized.

- Defrost Initiation Temperature: 13°F (-10°C). (8°F (-13.3°C) for pass thru units).
- Defrost Termination Temperature: 40°F (4.4°C).
- Defrost Initiated Time: Adjustable between 0 and 12 defrosts per 24 hrs. The factory default setting is 0. Before changing this setting, contact Hoshizaki Technical Support at 1-800-233-1940 for recommendations. When changed, the defrost setting will take effect after the next defrost based on the previous setting. If it is desired that this change in interval timing take effect immediately, turn the unit off and back on. The next time-initiated defrost initiates "x" hours after power is turned back on. For example, if the setting is dF 6, x=4 the next defrost takes place 4 hours from the time that power is turned back on.
- 1-Hour Defrost Backup Timer: When defrost is initiated (temperature or time), a 1-hour back-up defrost timer starts. The 1-hour back-up defrost timer terminates the defrost cycle in cases where the defrost thermistor fails to terminate the defrost cycle within 1 hour.

If necessary, adjust the time-initiated defrost frequency as follows:

- 1) Press and hold the up and down buttons simultaneously for 3 seconds. Press the "ENTER" button until "dF" is displayed.
- 2) To change the defrost frequency, press the up or down button until the desired value appears. The defrost frequency is adjustable between 0 and 12 defrosts per 24 hrs.

- 3) To save the value, press the "ENTER" button repeatedly until you have cycled through the menu and the unit returns to normal display mode. If you do not cycle through the menu and no button is pressed within 15 seconds, the display returns to normal and the defrost frequency remains unchanged.

c) *Temperature Display Scale (°F or °C)*

To change the display scale, follow the steps below.

- 1) Press and hold the up and down buttons simultaneously for 3 seconds. Press the "ENTER" button until "F" or "C" temperature display scale is displayed.
- 2) To change the temperature display, press the up or down buttons until the desired scale is displayed. The factory default is "F".
- 3) Press the "ENTER" button to save the value and return to normal display mode. If you do not press the "ENTER" button and no button is pressed within 15 seconds, the display returns to normal display and the temperature display scale remains unchanged.

6. Service Menu

From the service menu information regarding the functioning of the unit can be obtained. To access the service menu, press and hold the up and down buttons and the "ENTER" button simultaneously for 3 seconds. Scroll through the service menu list using the "ENTER" button. Change options using the up/down arrows. To exit, press the "ENTER" button until normal display mode returns. To exit the service menu at any point, press and hold the "ENTER" button for 3 seconds or the service menu display remains on the display board for 10 minutes after the last keystroke, then automatically reverts to normal operation (cabinet temperature display). All information given in degrees automatically displays in the current selected scale (°F or °C).

Display	Definition
1 OFF	Displays current cabinet temperature.
1 ON	Displays current evaporator temperature. Display will automatically revert to cabinet sensor after five minutes.
2 OFF	Manual forced defrost option not activated.
2 ON	Manual forced defrost option activated. Changing from 2 OFF to 2 ON initiates a forced defrost upon returning to the normal display mode.
3 OFF	Unconditional alarm reset option not activated.
3 ON	Unconditional alarm reset option activated. Changing from 3 OFF to 3 ON resets all alarm display codes simultaneously. This is a complete clearing of alarms.
4 16	Right two digits represent compressor run time in last 24 hours to the nearest hour. Example: 16 hours total run time in the last 24 hours.
5 50	Right two digits represent compressor on time percentage for the last 5 run cycles. A run cycle begins when the compressor switches from off to on and ends the next time it switches from off to on. (See diagram below). Example: 50% run time over the last 5 run cycles. Value is calculated as follows: Percent On Time = On Time Last 5 Cycles/Total Time Last 5 Cycles. Value is saved every 5 cycles. Note: "On Time Last 5 Cycles" does not include an on time that was terminated by a defrost cycle or the first on time after a defrost, and "Total Time Last 5 Cycles" does not include an on or off time that was terminated by a defrost cycle, the time spent in defrost, or the first on time after a defrost.
6 45	Right two digits represent compressor run time for the last run cycle. Example: 45 minutes of compressor run time in last run cycle.
7 45	Length of last defrost cycle (Freezer Only).
8 67	Right two digits represent highest cabinet temperature recorded during the last high temperature alarm. Example: Temperature reached 67 degrees during last high temperature alarm. Display will show "8--" if there has not been a high temperature alarm. Value is saved every 8.5 minutes when in alarm.
9-10	Right three places represent lowest cabinet temperature recorded during the last low temperature alarm. Example: Temperature reached -10 degrees during the last low temperature alarm. Display will show "9--" if there has not been a low temperature alarm. Value is saved every 8.5 minutes when in alarm.
R_ _ 0	

The diagram below is an example of a run cycle used to calculate run time:

Compressor Status

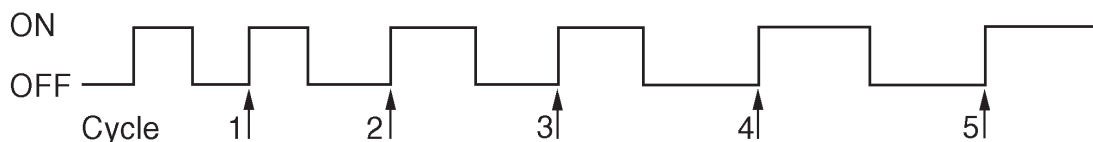

E. Compressor Thermal Overload and Short Cycle Protection

1. Compressor Thermal Overload: When a temperature or amperage value is above the limit specified by the compressor manufacturer, a thermal overload activates, turning off the compressor. The compressor restarts when the thermal overload resets.

- Compressor thermal overload resets automatically.
- If the condenser fan is operating and the compressor is off, it is most likely that the thermal overload opened.

2. Short Cycle Protection: There is a 2.5-minute compressor delay at start up and a 2.5-minute mandatory on time.

Any time the compressor turns off, it will remain off for a minimum of 2.5 minutes.

Any time the compressor starts, it will remain on for a minimum of 2.5 minutes.

Note: Time may vary with high pressure switch or thermal overload activation.

F. Perimeter Heater

This unit is equipped with a perimeter heater. The perimeter heater is controlled by the perimeter heater switch located on the control box. To help prevent the formation of condensation on the front frame, turn the perimeter heater on (perimeter heater switch red marking visible). When on, the perimeter heater cycles on and off with the compressor. If operating the unit under conditions where condensation does not form, this heater may be turned off (perimeter heater switch red marking hidden).

G. Thermistors

The cabinet thermistor is used for cabinet temperature control and the defrost thermistor is used for initiation and defrost termination. Thermistor resistance varies depending on temperature. The control board monitors the resistance to control system operation. No adjustment is required. For further details, see "IV.C. Thermistor Check."

III. Technical Data

A. Wiring Diagrams

1. RH_-SSE-XX (FG, HG, FS, or HS) Models

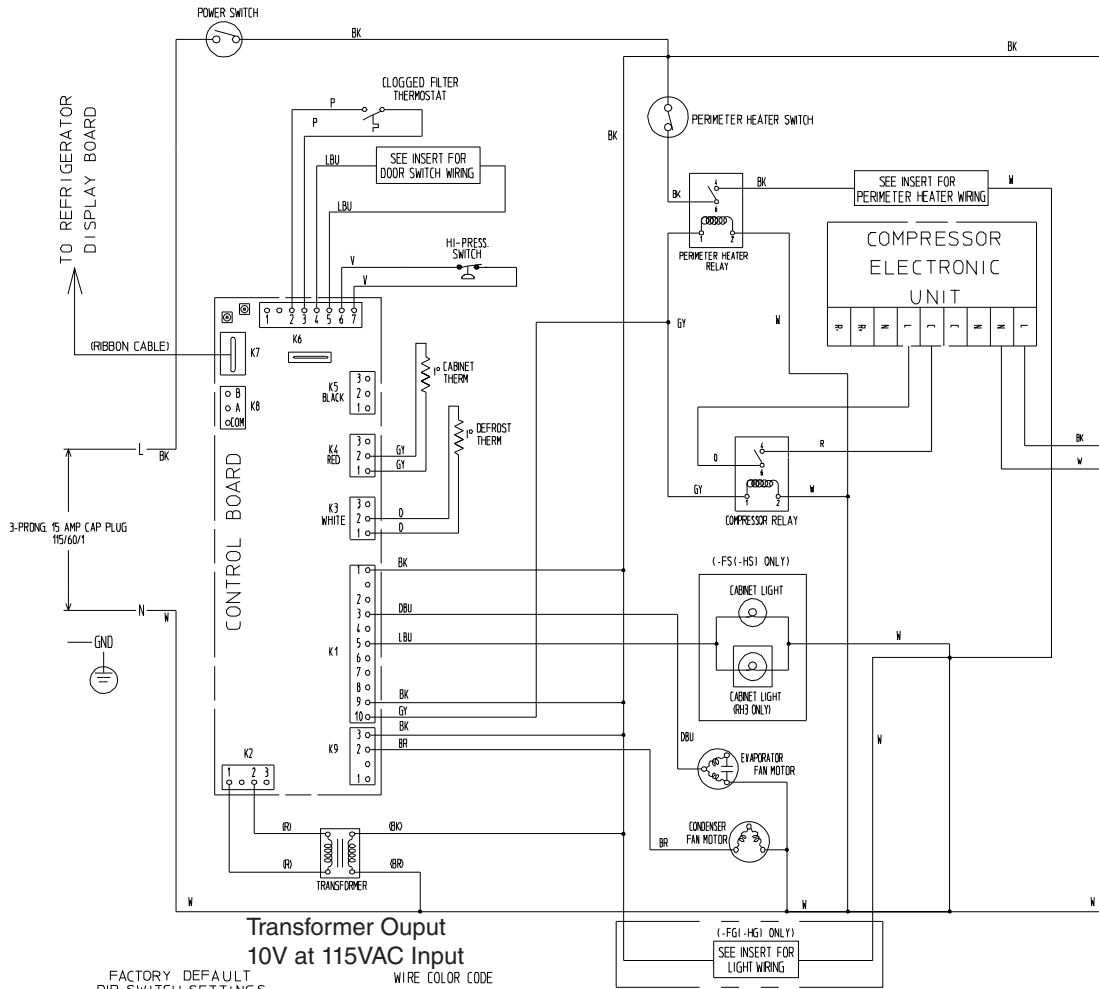

Transformer Output
10V at 115VAC Input

FACTORY DEFAULT
DIP SWITCH SETTINGS

DIP SWITCH SETTING	
NO. 1	ON
NO. 2	OFF
NO. 3	OFF
NO. 4	OFF
NO. 5	OFF
NO. 6	OFF
NO. 7	OFF
NO. 8	OFF

WIRE COLOR CODE

BR	BROWN
W	WHITE
BK	BLACK
R	RED
O	ORANGE
GY	GRAY
P	PINK
DBU	DARKBLUE
V	VIOLET
Y	YELLOW

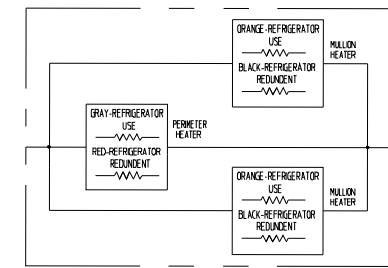

PERIMETER HEATER WIRING
(HEATERS WIRED IN PARALLEL)
(MULLION HEATER QUANTITY 1 PER MULLION)
(RH3 SHOWN)

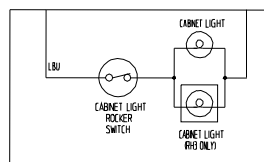

INCANDESCENT LIGHT WIRING
(-FG(-HG) ONLY)

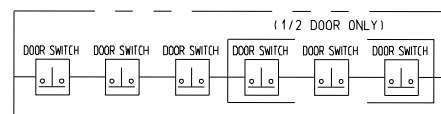

DOOR SWITCH WIRING
(SWITCHES WIRED IN SERIES)
(SWITCH QUANTITY 1 PER DOOR)
(RH3 1/2 DOOR SHOWN)

IV. Service Diagnosis

⚠ WARNING

1. This unit should be diagnosed and repaired only by qualified service personnel to reduce the risk of death, electric shock, serious injury, or fire.
2. Risk of electric shock. Use extreme caution and exercise safe electrical practices.
3. Moving parts (e.g., fan blade) can crush and cut. Keep hands clear.
4. Make sure all food zones are clean after the unit is serviced. For cleaning procedures, see "VI. Cleaning Instructions."

A. Diagnostic Procedure

The diagnostic procedure is basically a sequence check which can be used at unit startup or for system diagnosis. This procedure allows you to diagnose electrical system and component failures. Before conducting the diagnostic procedure, check for proper voltage per unit nameplate. The maximum allowable voltage variation is ± 10 percent of the nameplate rating. Check the control board S3 dip switch settings to assure that they are in the factory default position. Check CB using the steps in "IV.B. Control Board Check." For factory default settings, see "II.D.4.a) Default Dip Switch Settings." The service menu may be used to view history information. To access the service menu, press and hold the up and down buttons and "ENTER" button simultaneously for 3 seconds. Scroll through the service menu list using the "ENTER" button. For further details, see "II.D.6. Service Menu." As you go through the diagnostic procedure, check to assure the components energize and de-energize correctly. If not, those components or controls are suspect. Always choose a white (W) neutral wire to establish a good neutral connection when checking high voltages.

IMPORTANT

The maximum allowable voltage variation is ± 10 percent of the nameplate rating. 115VAC is used as reference voltage when checking voltage to components. Voltage may vary depending on power supply.

- 1) Raise the front panel and move the power switch to the "OFF" position.
- 2) Unplug the unit from the electrical outlet.
- 3) Remove the control box cover.
- 4) Plug the unit back into the electrical outlet.
- 5) Move the power switch to the "ON" position.
- 6) The red "POWER OK" LED on CB comes on and stays on while the unit is in operation.

- 7) **Startup—no component LEDs are on (LED 3 off for EvapFM operation):** There is a 5-second delay while CB identifies program revision. Revision (r###) is shown on DB. After 5-second delay, DB shows current cabinet temperature and EvapFM energizes. 2.5 minute Comp delay timer starts. **Diagnosis:** Check that red "POWER OK" LED is on. If not, verify incoming voltage supply. Check transformer input and output voltage (115VAC input and 10VAC output voltage) and transformer continuity. If 115VAC input and 10VAC output voltage is present, and the red "POWER OK" LED is off, CB is bad and must be replaced. Check that EvapFM is running. If not, check EvapFM blade for binding. Next, check for 115VAC at K1 connector pin #3 dark blue (DBU) to any white (W) neutral wire. If 115VAC is not present, CB is bad and must be replaced. If 115VAC is present, check EvapFM continuity.
- 8) **Cool-Down—LED 4 (Comp) and LED 5 (ConFM) are on:** EvapFM continues and 2.5 minute Comp delay timer terminates. Comp, ConFM, and PH energize (if PH switch is in the on position (red marking visible)).

Comp Circuit Diagnosis: If Comp does not start, check for 115VAC at K1 connector pin #10 gray (GY) wire to any white (W) neutral wire. If 115VAC is not present, CB is bad and must be replaced. If 115VAC is present, check for 115VAC at Comp relay coil gray (GY) wire to any white (W) neutral wire. If 115VAC is present, and Comp is not on, check for 115VAC at Comp relay orange (O) wire to Comp relay red (R) wire. If 115VAC is present, Comp relay is bad and must be replaced. If 115VAC is not present, check for 115VAC at Comp relay red (R) wire to any white (W) neutral wire. If 115VAC is not present, electronic unit is bad and must be replaced. If 115VAC is present, and Comp is not on, remove the electronic unit to access Comp terminals. Next, check for 80VAC from each Comp terminal to ground. If 80VAC is not present, electronic unit is bad and must be replaced. If 80VAC is present, check Comp continuity.

ConFM Diagnosis: If ConFM does not start, check that the fan blade is not binding. Next, check for 115VAC at red K9 connector pin #2 brown (BR) to any white (W) neutral wire. If 115VAC is not present, CB is bad and must be replaced. If 115VAC is present, check ConFM continuity.

If Comp and CondFM are on and the cabinet temperature is not dropping, check for a restriction in the refrigeration circuit, correct TXV operation, and correct refrigerant charge.

PH Diagnosis: Comp must be energized when troubleshooting PH. Confirm PH switch is on (red marking visible). Next, check for voltage at PH switch. 115VAC should be present from both black (BK) wires to any white (W) neutral wire. If 115VAC is present on one and not the other, the PH switch is open. Confirm 115VAC at the PH relay coil. Next, check for 115VAC from both black (BK) wires at the PH relay to any white (W) neutral wire. If 115VAC is present on one and not the other, the PH relay contacts are open. Check PH amp draw, if no amp draw is present, check the continuity of the PH.

9) Defrost–LED 5 (ConFM) is on:

Temperature-Initiated Defrost: Dth cools to 13°F (-10°C), CB initiates defrost. EvapFM and ConFM continue. Comp de-energizes. If ConFM is off, ConFM energizes once defrost starts.

Time-Initiated Defrost: If the factory time-initiated setting is moved from 0 defrost per 24 hours, the unit enters the defrost cycle once the time of the new setting expires. EvapFM and ConFM continue. Comp de-energizes. If ConFM is off, ConFM energizes once defrost starts.

Defrost Termination: Dth warms to 40°F (4.4°C). EvapFM and ConFM continue. 2.5 minutes later Comp and PH (if PH switch is on (red marking visible)) energize.

Diagnosis: Has Dth cooled to 13°F (-10°C)? Confirm Dth status, see "IV.C. Thermistor Check." Confirm that Comp stops. If not, check for 115VAC at K1 connector pin #10 gray (GY) wire to any white (W) neutral wire. If 115VAC is present, CB is bad and must be replaced. If Comp is on and 115VAC is not present, check Comp relay for closed contacts. Confirm EvapFM and ConFM continue to run. If not, check for 115VAC at K1 connector pin #3 dark blue (DBU) wire to any white (W) neutral wire for EvapFM and 115VAC at red K9 connector pin #2 brown (BR) to any white (W) neutral wire for ConFM. If 115VAC is not present, CB is bad and must be replaced. If 115VAC is present, check that EvapFM or ConFM is not binding. Then, check EvapFM and ConFM windings for continuity.

Confirm defrost termination. Confirm evaporator has warmed to defrost termination temperature of 40°F (4.4°C). Check Dth status, see "IV.C. Thermistor Check." 2.5 minutes later LED 4 comes on and Comp energizes. EvapFM and ConFM continue.

Legend: **CB**–control board; **ConFM**–condenser fan motor; **Comp**–compressor;
CTh–cabinet thermistor; **DB**–display board; **DTh**–defrost thermistor;
EvapFM–evaporator fan motor; **PH**–perimeter heater

B. Control Board Check

Before replacing a control board that does not show a visible defect and that you suspect is bad, always conduct the following check procedure. This procedure will help you verify your diagnosis. Always choose a white (W) neutral wire to establish a good neutral connection when checking high voltages.

Alarm Reset: If the control board is in alarm (beeping), press the "ALARM RESET" button on the control board with power on. For alarm information, see "II.D.3. LED Lights and Alarm Safeties Chart."

- 1) Check S3 dip switch settings to assure that they are in the factory default position. For factory default settings, see "II.D.4.a) Default Dip Switch Settings."
- 2) Move the power switch to the "ON" position. If the "POWER OK" LED is on, the control board voltage is good. If the "POWER OK" LED is off, check the control transformer secondary circuit. Transformer output is 10VAC at 115VAC primary input. If the secondary circuit has proper voltage (10VAC) and the "POWER OK" LED is off, the control board is bad and must be replaced. See "V.J. Removal and Replacement of Control Board."

If the secondary circuit does not have proper voltage, check the control transformer primary circuit. Check the power switch to a white (W) neutral wire.

- 3) The "OUTPUT TEST" button provides a relay sequence test. Move the power switch to the "ON" position. Next, press the "OUTPUT TEST" button. The control board cycles through all relays in sequence. The correct LED lighting sequence is 3, 2, 1, 4, 5. Note that the order of the LEDs from the outer edge of the board is 5, 4, 1, 2, 3. Components (e.g., compressor) cycle during the test. Following the output test, the unit resumes operation. If the LEDs do not light as described above, the control board is bad and must be replaced. See "V.J. Removal and Replacement of Control Board."
- 4) Confirm K6 connector output voltage (5VDC). Check at the following K6 connector locations: Pin #2 to pin #3 pink (P) wires (Clogged Filter Thermostat), pin #4 to pin #5 light blue (LBU) wires (Door Switch), and pin #6 to pin #7 violet (V) wires (High Pressure Switch).
- 5) Confirm proper output voltage (3.8VDC) at RED K4 connector (cabinet thermistor) pin #1 to pin #2 gray (GY) wires and WHITE K3 connector (defrost thermistor) pin #1 to pin #2 orange (O) wires.
- 6) As the unit cycles through the sequence of operation, check for 115VAC from K1 connector pins to corresponding components and relays as needed.

C. Thermistor Check

In the event the cabinet thermistor reading is out of range, the compressor operates on a fixed time basis of 5-minutes on and 5-minutes off.

In the event the defrost (evaporator) thermistor reading is out of range, defrost initiation occurs every 6 hours and terminates based on cabinet thermistor temperature.

In the event of both thermistor readings are out of range, the compressor operates on a fixed time basis of 5-minutes on and 5-minutes off and the defrost cycle initiates every 6 hours and terminates after 45 minutes.

To check thermistor resistance, follow the steps below.

- 1) Raise the front panel. Move the power switch to the "OFF" position, then unplug the unit.
- 2) Remove the control box cover.
- 3) Remove the cabinet and defrost thermistors. See "V.K. Removal and Replacement of Thermistor."
- 4) Disconnect the cabinet thermistor (gray (GY) wires) from the RED K3 connector or the defrost thermistor (orange (O) wires) from the WHITE K3 connector.
- 5) Immerse the thermistor sensor portion in a glass containing ice and water for 2 or 3 minutes.
- 6) Check the resistance between the wires at the thermistor connector (cabinet thermistor gray (G) wires or defrost thermistor orange (O) wires). Normal reading is within 4.7 to 6.2 k Ω . If outside the normal reading, replace the thermistor.
- 7) Replace the thermistors in their correct position. See "V.K. Removal Replacement of Thermistor."
- 8) Reconnect the red and white thermistor connectors to the control board RED K4 and WHITE K3 thermistor connectors.
- 9) Replace the control box cover in its correct position.
- 10) Plug the unit back in. Move the power switch to the "ON" position.
- 11) Close the front panel.

D. Diagnostic Chart

1. Unit Not Cooling

Problem	Possible Cause	Remedy	
[1] Unit does not start.	a) Power Supply	1. Unplugged, off, blown fuse, or tripped or defective circuit breaker.	1. Turn on, reset, or replace.
		2. Loose connection.	2. Tighten.
		3. Not within specifications.	3. Refer to nameplate and correct.
	b) Cord and Plug	1. Defective.	1. Replace.
	c) Power Switch (Control Box)	1. "OFF" Position.	1. Move to "ON" position.
		2. Bad contacts.	2. Check for continuity and replace.
	d) Control Transformer	1. Open coil winding.	1. Check continuity and replace.
	e) Wiring	1. Loose connection or open.	1. Tighten, check for continuity and repair.
		2. Faulty.	2. Check continuity and replace.
	f) Control Board	1. In alarm.	1. See "II.D.3. LED Lights and Alarm Safeties Chart."
		2. Defective.	2. Replace.
	g) High Pressure Switch (3 pressure trips in 1 hour, 6 beep alarm)	1. Bad contacts.	1. Check continuity and replace.
		2. Dirty air filter or condenser.	2. Clean
		3. Ambient temperature too warm.	3. Reduce temperature.
4. Refrigerant overcharge.		4. Recharge.	
5. Condenser fan not operating.		5. Replace.	
6. Refrigerant lines or components restricted.		6. Recover, repair, replace drier, evacuate, and recharge.	
h) Cabinet Thermistor	1. Defective.	1. Replace.	
i) Clogged Filter Thermostat	1. Clogged filter or condenser.	1. Clean filter or condenser coil.	
	2. Defective.	2. Replace.	
[2] Evaporator fan does not start.	a) Evaporator Fan Motor	1. Defective.	1. Replace.
	b) Control Board	1. Defective.	1. See "IV.B. Control Board Check."
[3] Cool down does not start. (compressor)	a) Setpoint	1. Incorrect.	1. Correct setpoint. Factory defaults: Refrigerator 36°F (2°C).
	b) Cabinet Thermistor	1. Defective.	1. Check thermistor reading and position. Replace.
	c) Control Board	1. In alarm.	1. See "II.D.3. LED Lights and Alarm Safeties Chart."
		2. Defective.	2. See "IV.B. Control Board Check."
	d) High Pressure Switch (5 pressure trips in 1 hour, 6 beep alarm)	1. Bad contacts.	1. Check continuity and replace.
		2. Dirty air filter or condenser.	2. Clean.
		3. Ambient temperature too warm.	3. Reduce temperature.
		4. Refrigerant overcharge.	4. Recharge.
		5. Condenser fan not operating.	5. Replace.
		6. Refrigerant lines or components restricted.	6. Recover, repair, replace drier, evacuate, and recharge.
	e) Compressor Relay	1. Bad contacts.	1. Replace.
2. Open coil windings.		2. Replace.	
f) Electronic Unit	1. Defective.	1. See "IV.A. Diagnostic Procedure."	

[3] Cool down does not start. (compressor) (continued)	g) Overload	1. Open.	1. Let compressor cool and overload reset. If overload does not reset, replace compressor. If overload resets, check compressor amperage and operating voltage.
		2. Clogged filter or condenser coil.	2. Clean.
		3. Condenser fan not operating.	3. Replace.
		4. Defective.	4. Replace.
		5. Open coil windings.	5. Replace.
	h) Compressor	1. Defective.	1. Replace.
[4] Cool down starts, temperature does not drop.	a) Location of Unit	1. Restricted air flow to condenser or ambient temperature too high.	1. Increase ventilation or lower ambient temperature.
	b) Cabinet Temperature too High	1. Warm food recently placed in cabinet area.	1. Pre-cool food product or allow time for unit to return to normal setpoint temperature.
		2. Air flow blocked.	2. Remove blockage or redistribute food products.
	c) Setpoint	1. Incorrect.	1. Correct setpoint. Factory defaults: Refrigerator 36°F (2°C).
	d) Door	1. Left open, opened too often.	1. Close, check for door open at time of warm cabinet temperature.
		2. Not sealing.	2. Check for proper sealing.
	e) Cabinet Thermistor	1. Defective.	1. Check thermistor reading and position. Replace.
	f) Clogged Filter Thermostat	1. Clogged filter or condenser coil.	1. Clean filter or condenser coil.
		2. Defective.	2. Replace.
	g) Evaporator	1. Clogged or frozen.	1. Clean. Defrost and check defrost cycle.
	h) Evaporator Fan Motor	1. Defective.	1. Replace.
	i) Defrost	1. Not enough defrosts occurring per day.	1. See "II.D.5.b) Defrost Frequency."
		2. Defrost Thermistor.	2. Check position and ohm reading. Reposition in evaporator. See "IV.C. Thermistor Check."
		3. Control Board.	3. Replace.
	j) Control Board	1. Defective.	1. See "IV.B. Control Board Check."
k) Refrigerant/Refrigerant Lines	1. Gas leaks.	1. Check for leaks with a leak detector. Repair leaks. Replace drier, evacuate and recharge. See "V.A. Service for Refrigerant Lines."	
	2. Refrigerant lines restricted.	2. Recover, repair, replace drier, evacuate, and recharge.	
l) Expansion Valve (TXV) (not adjustable)	1. Defective.	1. Replace.	
m) Electronic Unit Voltage	1. Defective.	1. Replace.	
n) Compressor	1. Defective.	1. Replace.	

[5] Cabinet Temperature Too Low	a) Setpoint	1. Incorrect.	1. Correct setpoint. Factory defaults: Refrigerator 36°F (2°C).
	b) Cabinet Thermistor	1. Defective.	1. Check and replace.
	c) Evaporator Fan Motor	1. Defective.	1. Replace.
	d) Control Board	1. Defective.	1. See "IV.B. Control Board Check."

2. Evaporator is Frozen Up

[1] Evaporator does not defrost completely.	a) Defrost Frequency	1. Not enough defrosts occurring per day. Operation in humid conditions.	1. See "II.D.5. b) Defrost Frequency."
	b) Defrost Thermistor	1. Out of position or defective.	1. Reposition or replace.
	c) Control Board	1. Defective.	1. Replace.
[2] Compressor on during defrost.	a) Compressor Relay	1. Bad Contacts.	1. Replace.
	b) Control Board	1. Defective.	1. See "IV.B. Control Board Check."

3. Defrost Fails to Terminate

[1] Defrost cycle too long.	a) Defrost Thermistor	1. Out of position or defective.	1. Reposition or replace.
	b) Defrost Frequency	1. Not enough defrosts occurring per day. Operation in humid conditions.	1. See "II.D.5.b) Defrost Frequency."
	c) Control Board	1. Defective.	1. See "IV.B. Control Board Check."
[2] Compressor operates during defrost.	a) Compressor Relay	1. Bad Contacts.	1. Replace relay.
	b) Control Board	1. Defective.	1. Replace.

4. Other

[1] Abnormal Noise.	a) Fasteners	1. Loose fasteners allow vibration of part.	1. Tighten fasteners.
	b) Compressor	1. Problem with mount or electronic unit.	1. Properly mount compressor. Replace any missing grommets.
		2. Floodback to compressor.	2. Check for signs of floodback to compressor. Evacuate and recharge if necessary.
		3. Defective.	3. Replace.
	c) Fan (evaporator or condenser)	1. Fan blade loose.	1. Adjust and tighten.
2. Defective motor.		2. Replace.	
d) Relay	1. Chattering.	1. Replace.	
[2] Condensate water overflow.	a) Cabinet Contents	1. Loading of large volumes of warm, moist, uncovered product.	1. Allow product to cool before placing in cabinet. Cover product with plastic wrap.
	b) Location of Unit	1. Unit located near high humidity source such as fryer, steamer, etc.	1. Relocate.
	c) Seals	1. Poor sealing around evaporator, door gaskets.	1. Adjust or replace.
	d) Environment	1. Extreme environment and door-opening conditions.	1. Adjust conditions.

V. Removal and Replacement of Components

⚠ WARNING

1. This unit should be diagnosed and repaired only by qualified service personnel to reduce the risk of death, electric shock, serious injury, or fire.
2. Move the power switch to the "OFF" position and unplug the unit from the electrical outlet before servicing.

A. Service for Refrigerant Lines

⚠ WARNING

1. Repairs requiring the refrigeration circuit to be opened must be performed by properly trained and EPA-certified service personnel.
2. Always recover the refrigerant and store it in an approved container. Do not discharge the refrigerant into the atmosphere.
3. Use an electronic leak detector or soap bubbles to check for leaks. Add a trace of refrigerant to the system (if using an electronic leak detector), and then raise the pressure using nitrogen gas (140 PSIG). DO NOT use R-134a as a mixture with pressurized air for leak testing.

CAUTION

1. Do not leave the system open for longer than 15 minutes when replacing or servicing parts. The Polyol Ester (POE) oils used in R-134a units can absorb moisture quickly. Therefore it is important to prevent moisture from entering the system when replacing or servicing parts.
2. Always install a new drier every time the sealed refrigeration system is opened.
3. Do not replace the drier until after all other repair or replacement has been made. Install the new drier with the arrow on the drier in the direction of the refrigerant flow.
4. When brazing, protect the drier by using a wet cloth to prevent the drier from overheating. Do not allow the drier to exceed 250°F (121°C).

1. Refrigerant Recovery

The unit is provided with refrigerant access valves. Using proper refrigerant practices recover the refrigerant from the access valves and store it in an approved container. Do not discharge the refrigerant into the atmosphere.

2. Brazing

▲ WARNING

1. R-134a itself is not flammable at atmospheric pressure and temperatures up to 176°F (80°C).
2. R-134a itself is not explosive or poisonous. However, when exposed to high temperatures (open flames), R-134a can be decomposed to form hydrofluoric acid and carbonyl fluoride both of which are hazardous.
3. Do not use silver alloy or copper alloy containing arsenic.
4. Use an electronic leak detector or soap bubbles to check for leaks. Add a trace of refrigerant to the system (if using an electronic leak detector), and then raise the pressure using nitrogen gas (140PSIG). DO NOT use R-134a as a mixture with pressurized air for leak testing.

- 1) Braze all fittings while purging with nitrogen gas flowing at a pressure of 3 to 4 PSIG.

CAUTION

1. Always install a new drier every time the sealed refrigeration system is opened.
2. Do not replace the drier until after all other repair or replacement has been made. Install the new drier with the arrow on the drier in the direction of the refrigerant flow.
3. When brazing, protect the drier by using a wet cloth to prevent the drier from overheating. Do not allow the drier to exceed 250°F (121°C).

- 2) Use an electronic leak detector or soap bubbles to check for leaks. Add a trace of refrigerant to the system (if using an electronic leak detector), and then raise the pressure using nitrogen gas (140 PSIG). DO NOT use R-134a as a mixture with pressurized air for leak testing.

Note: Because the pipes in the evaporator case are specially coated to resist corrosion, it is important to make connections outside the evaporator case when possible. If it is necessary to braze inside the evaporator case, use sandpaper to remove the coating from the brazing connections before unbrazing the components.

3. Evacuation and Recharge (R-134a)

- 1) Attach a vacuum pump to the system. Be sure the charging hoses are connected to both high and low-side access valves.

IMPORTANT

The vacuum level and vacuum pump may be the same as those for current refrigerants. However, the rubber hose and gauge manifold to be used for evacuation and refrigerant charge should be exclusively for POE oils.

- 2) Turn on the vacuum pump. Never allow the oil in the vacuum pump to flow backwards.
- 3) Allow the vacuum pump to pull down to a 29.9" Hg vacuum. Evacuating period depends on pump capacity.

- 4) Close the low-side valve and high-side valve on the service manifold.
- 5) Disconnect the gauge manifold hose from the vacuum pump and attach it to a refrigerant service cylinder. Remember to loosen the connection and purge the air from the hose. See the nameplate for the required refrigerant charge. Hoshizaki recommends only virgin refrigerant or reclaimed refrigerant which meets ARI Standard 700 (latest edition) be used.
- 6) A liquid charge is recommended for charging an R-134a system. Invert the service cylinder and place it on scales. Open the high-side valve on the gauge manifold valve.
- 7) Allow the system to charge with liquid until the proper charge weight is met.
- 8) If necessary, add any remaining charge to the system through the low-side. Use a throttling valve or liquid dispensing device to add the remaining liquid charge through the low-side access port with the unit running.
- 9) Close gauge manifold valves and disconnect the hoses and service manifold.
- 10) Cap the access valves to prevent a possible leak.

B. Removal and Replacement of Compressor

CAUTION

1. Always install a new drier every time the sealed refrigeration system is opened.
2. Do not replace the drier until after all other repair or replacement has been made. Install the new drier with the arrow on the drier in the direction of the refrigerant flow.
3. When brazing, protect the drier by using a wet cloth to prevent the drier from overheating. Do not allow the drier to exceed 250°F (121°C).

Note: Due to the ability of the POE oil in the compressor to absorb moisture quickly, the compressor must not be opened more than 15 minutes for replacement or service. Do not mix lubricants of different compressors even if both are charged with R-134a, except when they use the same lubricant.

- 1) Raise the front panel. Then, move the power switch to the "OFF" position and unplug the unit.
- 2) Remove the panels.
- 3) Recover the refrigerant and store it in an approved container. See "V.A. Service for Refrigerant Lines."
- 4) Loosen the 2 screws securing the compressor electronic unit to the compressor. See Fig. 3. Remove the electronic unit from the compressor.
- 5) Remove the discharge and suction pipes.
- 6) Remove the hold-down bolts, washers, and rubber grommets.
- 7) Remove the compressor.
- 8) Place the new compressor in position and secure it using the grommets, washers and bolts.

- 9) Remove the drier, then place the new drier in position.
- 11) Remove plugs from the suction, discharge, and process pipes.
- 12) Braze all fittings while purging with nitrogen gas flowing at a pressure of 3 to 4 PSIG. See "V.A.2. Brazing."
- 13) Use an electronic leak detector or soap bubbles to check for leaks. Add a trace of refrigerant to the system (if using an electronic leak detector), and then raise the pressure using nitrogen gas (140 PSIG). DO NOT use R-134a as a mixture with pressurized air for leak testing.
- 14) Evacuate the system, and charge it with refrigerant. See "V.A.3. Evacuation and Recharge (R-134a)." See the nameplate for the required refrigerant charge.
- 15) Connect and secure the compressor electronic unit to the new compressor.
- 16) Replace the panels in their correct positions.
- 17) Plug the unit back in. Move the power switch to the "ON" position.
- 18) Close the front panel.

C. Removal and Replacement of Compressor Electronic Unit

CAUTION! Do not attempt to repair the compressor electronic unit.

- 1) Raise the front panel, then move the power switch to the "OFF" position and unplug the unit.
- 2) Remove the rear panel.
- 3) Loosen the 2 screws securing the compressor electronic unit to the compressor. See Fig. 3. Remove the electronic unit from the compressor.
- 4) Remove the wire cover from the compressor electronic unit, then disconnect the wires from the compressor electronic unit.
- 5) Remove the wire cover from the new compressor electronic unit and connect the wires. Replace and secure the wire cover.
- 6) Secure the new electronic unit to the compressor.
- 7) Replace the rear panel in its correct position.
- 8) Plug the unit back in. Move the power switch to the "ON" position.
- 9) Close the front panel.

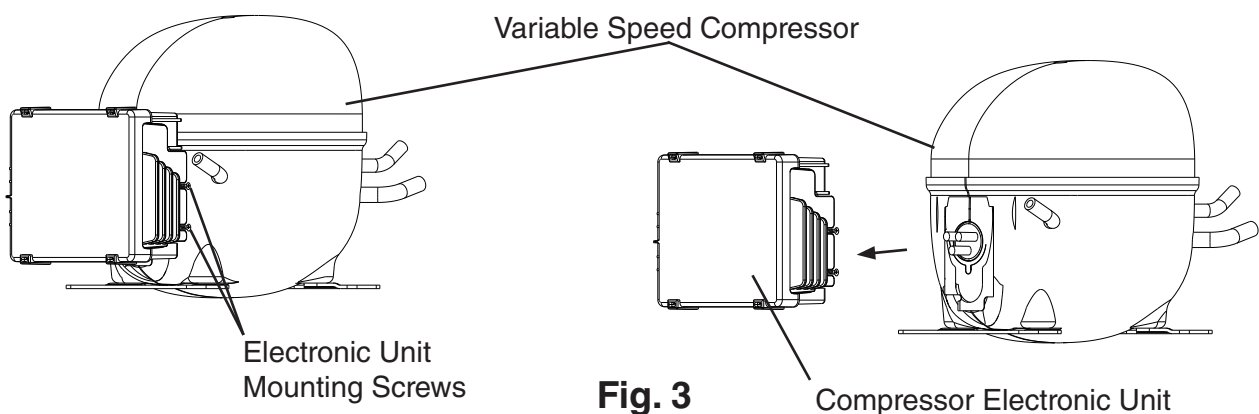

D. Removal and Replacement of Expansion Valve

Moisture in the refrigeration circuit may exceed drier capacity and freeze up at the expansion valve.

CAUTION

1. Always install a new drier every time the sealed refrigeration system is opened.
2. Do not replace the drier until after all other repair or replacement has been made. Install the new drier with the arrow on the drier in the direction of the refrigerant flow.
3. When brazing, protect the valve body and drier by using wet cloths to prevent the valve body and drier from overheating. Do not allow the valve body or drier to exceed 250°F (121°C).

- 1) Raise the front panel, then move the power switch to the "OFF" position and unplug the unit.
- 2) Remove the evaporator case cover and panels.
- 3) Recover the refrigerant and store it in an approved container.
- 4) Remove the insulation and the expansion valve bulb on the suction line.
- 5) Remove the expansion valve cover and disconnect the expansion valve. Place the new expansion valve in position.
- 6) Remove the drier, then place the new drier in position.
- 7) Braze all fittings while purging with nitrogen gas flowing at a pressure of 3 to 4 PSIG. See "V.A.2. Brazing."
- 8) Use an electronic leak detector or soap bubbles to check for leaks. Add a trace of refrigerant to the system (if using an electronic leak detector), and then raise the pressure using nitrogen gas (140 PSIG). DO NOT use R-134a as a mixture with pressurized air for leak testing.
- 9) Evacuate the system, and charge it with refrigerant. See "V.A.3. Evacuation and Recharge (R-134a)." See the nameplate for the required refrigerant charge.
- 10) Attach the expansion valve bulb to the suction line in the same location as the previous bulb. The bulb should be between the 10 and 2 o'clock position on the tube. Be sure to secure the bulb with the clamp and holder and to insulate it.
- 11) Place the expansion valve cover in position.
- 12) Replace the evaporator case cover and panels in their correct positions.
- 13) Plug the unit back in. Move the power switch to the "ON" position.
- 14) Close the front panel.

E. Removal and Replacement of Evaporator

CAUTION

1. Always install a new drier every time the sealed refrigeration system is opened.
2. Do not replace the drier until after all other repair or replacement has been made. Install the new drier with the arrow on the drier in the direction of the refrigerant flow.
3. When brazing, protect the drier by using a wet cloth to prevent the drier from overheating. Do not allow the drier to exceed 250°F (121°C).

- 1) Raise the front panel, then move the power switch to the "OFF" position and unplug the unit.
- 2) Remove the evaporator case cover and panels.
- 3) Recover the refrigerant and store it in an approved container.
- 4) Remove the insulation tubing, then disconnect the evaporator tubing. Elevate the evaporator to avoid overheating of the evaporator housing. Lift out the evaporator.
Note: The pipes in the evaporator case are specially coated to resist corrosion. Use sandpaper to remove the coating from the brazing connections before unbrazing.
- 5) Place the new evaporator in position.
- 6) Remove the drier, then place the new drier in position.
- 7) Braze all fittings while purging with nitrogen gas flowing at a pressure of 3 to 4 PSIG. See "V.A.2. Brazing."
- 8) Use an electronic leak detector or soap bubbles to check for leaks. Add a trace of refrigerant to the system (if using an electronic leak detector), and then raise the pressure using nitrogen gas (140 PSIG). DO NOT use R-134a as a mixture with pressurized air for leak testing.
- 9) Evacuate the system, and charge it with refrigerant. See "V.A.3. Evacuation and Recharge (R-134a)." See the nameplate for the required refrigerant charge.
- 10) Replace the removed parts in the reverse order of which they were removed.
- 11) Replace the evaporator case cover and panels in their correct positions.
- 12) Plug the unit back in. Move the power switch to the "ON" position.
- 13) Close the front panel.

F. Removal and Replacement of Evaporator Fan Motor

- 1) Raise the front panel, then move the power switch to the "OFF" position and unplug the unit.
- 2) Remove the evaporator case cover and panels.
- 3) Remove the screws securing the evaporator fan bracket, then remove the evaporator fan bracket and fan motor.
- 4) Remove the fan motor bracket from the fan motor and secure it to the new fan motor.
- 5) Install the new fan motor assembly.
- 6) Replace the evaporator case cover and panels in their correct positions.
- 7) Plug the unit back in. Move the power switch to the "ON" position.
- 8) Close the front panel.

G. Removal and Replacement of Door Gasket

Remove old gasket by pulling it directly out of the vinyl gasket retainer. Thoroughly clean the gasket area with mild soap and water prior to installing the new gasket. The new gasket should be installed by assembling it at the corners first, then working toward the center at the top, bottom, and sides. The arrow-shaped portion of the gasket should be firmly seated in the retainer groove for proper assembly. This can be checked by lifting the edge of the gasket and observing the engagement.

CAUTION

In order to get a proper gasket fit, it is important not to stretch gasket material during assembly.

H. Removal and Replacement of Door Closure Spring

⚠ WARNING

Wear eye protection and use caution when removing the tension screw (step 3).

- 1) Raise the front panel. Then, move the power switch to the "OFF" position and unplug the unit.
- 2) Remove the wire cover. See Fig. 4.
- 3) Remove the bushing cover from the top of the spring guide pin.
- 4) Insert a small drift pin or long leg of an allen wrench into one of the threaded tension screw holes in the spring guide pin. Turn the spring guide pin to access the tension screw. Securely hold the spring guide pin in this position while removing the tension screw. Carefully rotate (walk) the spring guide pin to release spring tension.
- 5) Use a 1/2" socket wrench to remove the top pivot pin and hinge washer from the top hinge bracket.
- 6) Firmly grasp the door and pull it forward at the top. Then raise the door, disengaging it from the bottom pivot pin.
- 7) Remove the spring guide pin and spring from the spring cartridge.
- 8) Replace the spring with one of the same color. Be certain that the spring ends are engaged in both the spring cartridge and the top of the spring guide pin.
- 9) Reverse procedure to reassemble door(s) to cabinet.
Note: Tighten spring guide pin one complete rotation to set proper spring tension.
- 10) Replace the wire cover in its correct position.
- 11) Plug the unit back in. Move the power switch to the "ON" position.
- 12) Close the front panel.

Side	Color	Part Number
Left	Blue	4A3312-02
Right	Black	4A3312-01

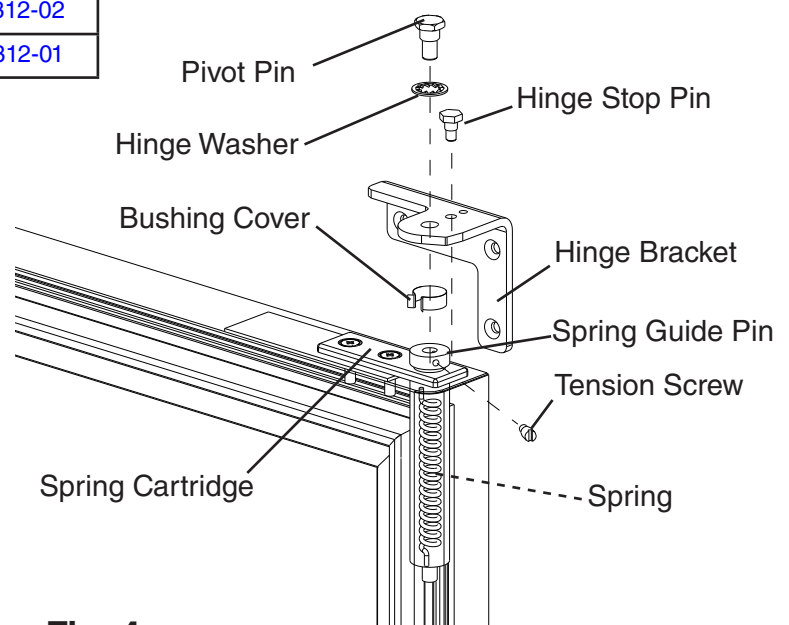
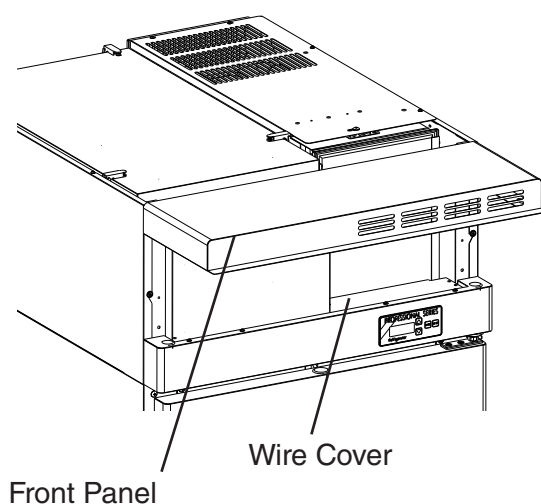

Fig. 4

I. Door Re-Hinging

The door on any unit is reversible as shown below. The instructions for re-hinging are provided in the kits listed below.

Convert	Door Type	Kit Number
Right to Left	Full	HS-3527
Left to Right	Full	HS-3528
Right to Left	Half	HS-3529
Left to Right	Half	HS-3530

J. Removal and Replacement of Control Board

- 1) Raise the front panel. Then, move the power switch to the "OFF" position and unplug the unit.
- 2) Remove the control box cover.
- 3) Unhook all wiring connections to the control board.
- 4) Remove the control board by carefully squeezing the tips of the board mounts.
- 5) Verify that the S3 dip switches are set correctly. See "II.D.4.a) Default Dip Switch Settings."
- 6) Place the control board into its correct position, taking care not to damage it.
- 7) Connect all wiring connections to the control board.
- 8) Replace the control box cover in its correct position.
- 9) Plug the unit back in. Move the power switch to the "ON" position.
- 10) Close the front panel.

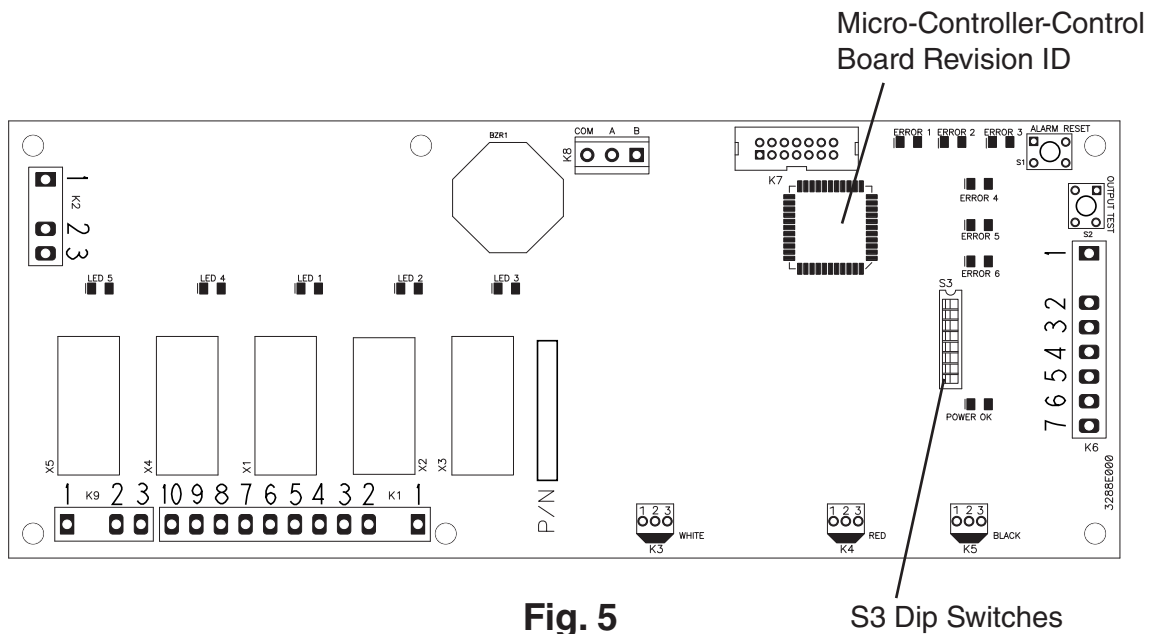

Fig. 5

S3 Dip Switches

K. Removal and Replacement of Thermistors

This section covers removal and replacement of the cabinet and defrost thermistors. For a thermistor check procedure, see "IV.C. Thermistor Check."

CAUTION

1. The thermistors are fragile; handle very carefully.
2. Do not shorten or cut the thermistor leads.

1. Cabinet Thermistor

- 1) Raise the front panel. Move the power switch to the "OFF" position, then unplug the unit.
- 2) Remove the evaporator case cover.
- 3) Remove the control box cover.
- 4) Disconnect the cabinet thermistor (gray (GY) wires) from the RED K4 connector on the control box.
- 5) Remove the cabinet thermistor from the thermistor bracket. Remove the thermistor.
- 6) Place the new cabinet thermistor in the thermistor bracket. Then, route the thermistor connector to the control box.
- 7) Connect the cabinet thermistor (gray (GY) to the RED K4 connector on the control board.
- 8) Replace the evaporator case cover and control box cover.
- 9) Plug the unit back in. Move the power switch to the "ON" position.
- 10) Close the front panel.

2. Defrost Thermistor

- 1) Raise the front panel. Move the power switch to the "OFF" position, then unplug the unit.
- 2) Remove the evaporator case cover.
- 3) Remove the control box cover.
- 4) Disconnect the defrost thermistor connector (orange (O) wires) from the WHITE K3 connector on the control box.
- 5) Remove the defrost thermistor clip from the evaporator (note the location in the evaporator). Remove the defrost thermistor from the defrost thermistor clip.
- 6) Place the new defrost thermistor in the defrost thermistor clip, then insert it back into its original position in the evaporator. Route the defrost thermistor connector to the control box.
- 7) Connect the defrost thermistor connector (orange (O) wires) to the WHITE K3 connector on the control board.
- 8) Replace the evaporator case cover and control box cover.
- 9) Plug the unit back in. Move the power switch to the "ON" position.
- 10) Close the front panel.

VI. Cleaning Instructions

1. Stainless Steel Exterior

Wipe the exterior occasionally with a clean, soft cloth. Use a damp cloth containing a neutral cleaner to wipe off oil or dirt build up.

2. Stainless Steel Interior

Spills should be wiped up promptly to avoid unpleasant odors. The cabinet interior should be cleaned periodically with a mild soap or detergent.

3. Door Gaskets

Door gaskets should be cleaned regularly with mild soap and water to remove dirt and grease.

4. Air Filter

Check the filter at least once a month. If it is dirty, use warm water and a neutral cleaner to wash the filter.

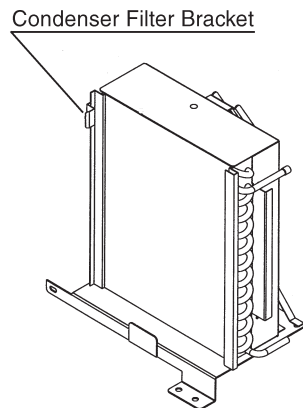

Fig. 6

5. Condenser

Check the condenser once a year and use a brush or vacuum cleaner to clean the unit as required.

6. Glass Door

Wipe occasionally with a clean, soft cloth. Use a damp cloth containing a neutral cleaner to wipe off oil or dirt build up.