



HOSHIZAKI

Instruction Manual

Counter Showcase

Models

HNC-120BA-L/R-S

HNC-150BA-L/R-S

HNC-180BA-L/R-S

HNC-210BA-L/R-S



hoshizakiamerica.com

Issued: 8-1-2016

⚠ WARNING

Only qualified service technicians should install and service the appliance. To obtain the name and phone number of your local Hoshizaki Certified Service Representative, visit www.hoshizaki.com. No installation or service should be undertaken until the technician has thoroughly read this Instruction Manual. Likewise, the owner/manager should not proceed to operate the appliance until the installer has instructed them on its proper operation. Failure to install, operate, and maintain the appliance in accordance with this manual will adversely affect safety, performance, component life, and warranty coverage and may result in costly water damage. Proper installation is the responsibility of the installer. Product failure or property damage due to improper installation is not covered under warranty.

Hoshizaki provides this manual primarily to assist qualified service technicians in the installation, maintenance, and service of the appliance.

Should the reader have any questions or concerns which have not been satisfactorily addressed, please call, send an e-mail message, or write to the Hoshizaki Technical Support Department for assistance.

Phone: 1-800-233-1940; (770) 487-2331

Fax: 1-800-843-1056; (770) 487-3360

E-mail: techsupport@hoshizaki.com

HOSHIZAKI AMERICA, INC.

618 Highway 74 South

Peachtree City, GA 30269

Attn: Hoshizaki Technical Support Department

NOTE: To expedite assistance, all correspondence/communication MUST include the following information:

- Model Number _____
- Serial Number _____
- Complete and detailed explanation of the problem.

IMPORTANT

This manual should be read carefully before the appliance is installed and operated. Read the warnings and guidelines contained in this manual carefully as they provide essential information for the continued safe use and maintenance of the appliance. Retain this manual for any further reference that may be necessary.



CONTENTS

PAGE

Important Safety Information-----	3
I. General Information -----	4
A. Construction -----	4
II. Installation and Operating Instructions-----	5
A. Checks Before Installation -----	5
B. Location-----	5
C. Setup-----	6
D. Electrical Connections -----	7
E. Drain Connections -----	7
F. Final Checklist-----	8
G. Start Up-----	8
III. Maintenance and Cleaning Instructions -----	10
A. Interior/Exterior -----	10
B. Drain Pipe Cleaning -----	10
C. Air Filter-----	11
D. Condenser -----	11
E. Checking Ground Fault Circuit Interrupter -----	11

Important Safety Information

Throughout this manual, notices appear to bring your attention to situations which could result in death, serious injury, damage to the appliance, or damage to property.

-  WARNING** Indicates a hazardous situation which could result in death or serious injury.
-  AVERTISSEMENT** Signale une situation dangereuse qui peut entraîner des blessures graves voire mortelles.
- NOTICE*** Indicates a situation which could result in damage to the appliance or property.
- IMPORTANT*** Indicates important information about the installation, use, and care of the appliance.

I. General Information

A. Construction

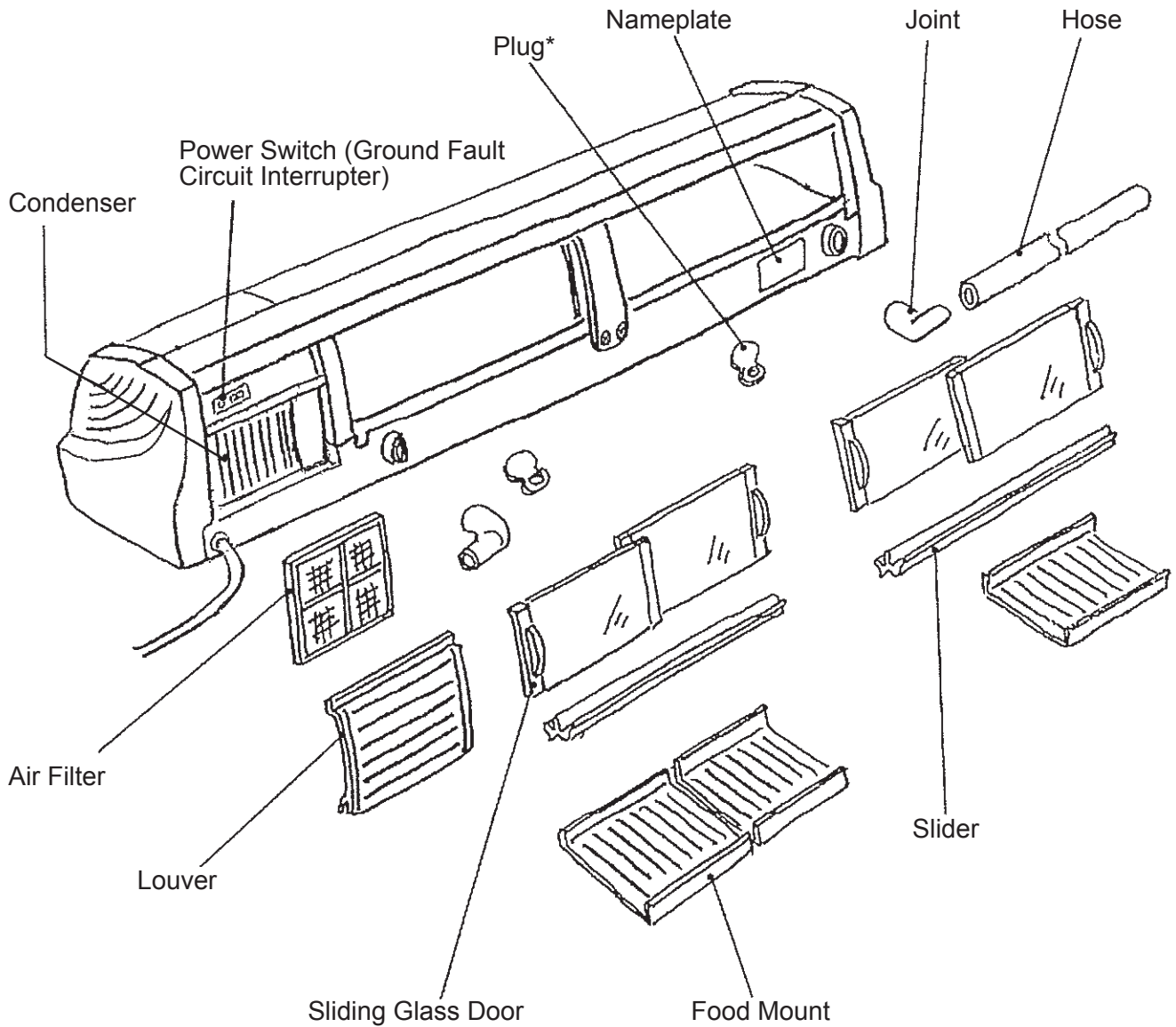

*Note: Always attach the plug(s) to the drain holes located in the showcase.

Fig. 1

II. Installation and Operating Instructions

A. Checks Before Installation

- * Visually inspect the exterior of the shipping container, and any severe damage noted should be reported to the carrier.

NOTICE
Remove shipping carton, evaporator spacer, tape and packing material. If packing material is left in the showcase, it will not work properly.

IMPORTANT
Remove shipping tape holding the door.

- * Remove the package containing accessories.
- * See the nameplate on the rear of the showcase, and check that your voltage supplied corresponds with the voltage specified on the nameplate.

B. Location

⚠ WARNING
This showcase is not intended for outdoor use.
⚠ AVERTISSEMENT
Cette vitrine n'a pas été conçue pour être utilisée à l'extérieur.

IMPORTANT
Normal operating ambient temperature should be within 50°F (10°C) to 80°F (27°C). Operation of the showcase, for extended periods, outside of this normal temperature range may affect cooling performance.

For best operating results:

- * The showcase should not be located next to ovens, grills or other high heat producing equipment.

- * The location should provide a firm foundation for the equipment where its entire bottom surface can be steadily positioned. Level the showcase from side to side and front to rear. Installation of the showcase only partly in contact with the foundation may result in deformation, damage or failure.



Fig. 2

If the foundation is not firm enough, it may warp and cause some space between its center and the showcase bottom. In this case, provide a support to keep the foundation level.

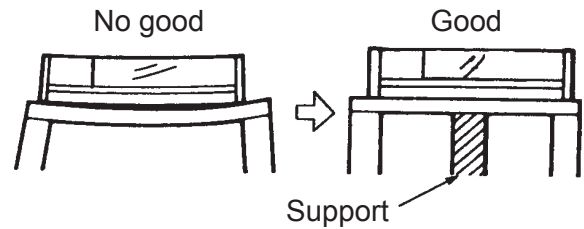

Fig. 3

- * Avoid a site where dripping is not allowed.
- * Do not expose the showcase to direct sunlight or higher temperatures to prevent damage to the plastic housing. Adding additional heat will also affect showcase operating temperatures. Assure that there is no heat producing equipment located near the case, no heating vents blowing on the case, or high wattage lamps shining on the case.
- * Allow at least 6" (15cm) clearance between the condenser air inlet/outlet and the wall or other equipment for proper air circulation. The rear of the showcase should have enough space for smooth operation of the power switch and for easy access to the louver and air filter. Open space is required at the top of the showcase.

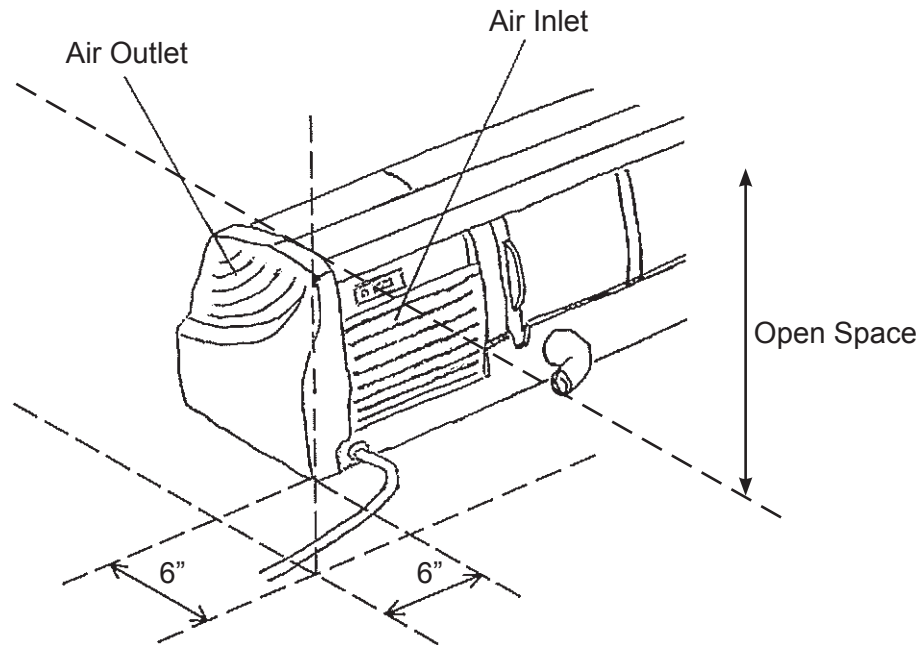

Fig. 4

C. Setup

⚠ WARNING
Carry the showcase by holding its bottom.
⚠ AVERTISSEMENT
Portez la vitrine en la tenant par le fond.

- 1) Unpack the showcase, and remove the shipping carton, evaporator spacer, tape and packing material BEFORE operating the unit. Be careful not to damage the exterior panels when handling the showcase.
- 2) Position the showcase in a selected site. Clean the interior with soap and water and rinse thoroughly.
- 3) Level the showcase in both the left-to-right and the front-to-rear directions.
- 4) The perimeter where the machine touches the counter should be sealed with silicone.

D. Electrical Connections

- * The showcase requires an independent power supply of proper capacity. See the nameplate for electrical specifications. The maximum allowable voltage variation is ± 10 percent of the nameplate rating.
- * **THE SHOWCASE MUST BE GROUNDED.** The showcase is equipped with a NEMA 5-15 three-prong grounding plug to reduce the risk of potential shock hazards. It must be plugged into a properly grounded, independent 3-prong wall outlet.

E. Drain Connections

- * The hose may be connected to either right or left joint, whichever is convenient.
- * Keep more than 2 vertical inch (5 vertical cm) air gap between the drain pipe end and the sink.

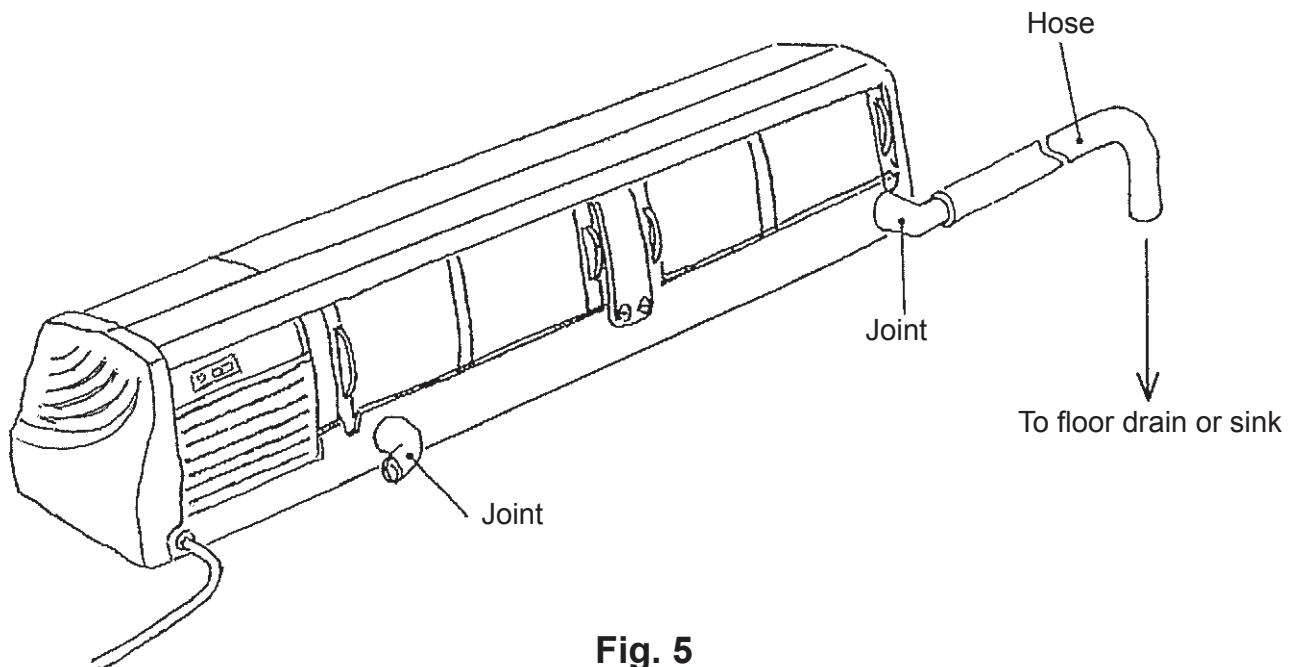
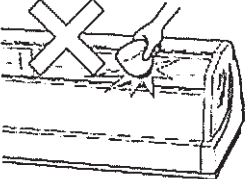
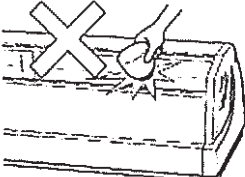
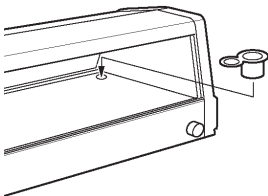

Fig. 5

F. Final Checklist

- 1) Is the showcase level?
- 2) Is the showcase in a site where the ambient temperature is within 50°F (10°C) to 80°F (27°C) all year around?
- 3) Have the shipping carton, evaporator spacer, tape and packing material been removed from the showcase?
- 4) Have all electrical and piping connections been made?
- 5) Has the power supply voltage been tested or checked against the nameplate rating?
- 6) Has the user been given the instruction manual and instructed on how to operate the showcase and the importance of periodic maintenance recommended?
- 7) Has the user been given the contact information of the authorized service agency?

G. Start Up

⚠ WARNING	
<ul style="list-style-type: none">• Be careful not to let water into the machine compartment and over the exterior. This might cause an electric shock hazard.• To prevent damage to the glass parts, do not place or hit any tableware, bottles or edged tools directly on the glass surfaces. Even a tiny flaw may grow into a crack (a few days) later.	
⚠ AVERTISSEMENT	
<ul style="list-style-type: none">• Attention de ne pas laisser d'eau pénétrer dans le compartiment de l'appareil et s'écouler sur l'extérieur. Ceci pourrait entraîner un risque de choc électrique.• Pour éviter d'endommager les parties en verre, ne placez pas de couverts, d'assiettes, de bouteilles ni d'outils pointus directement sur les surfaces de verre. Même la plus petite des fêlures peut devenir une fissure (quelques jours) plus tard.	
NOTICE	
<ul style="list-style-type: none">• Do not plug in and unplug the showcase frequently. This may result in failure or shorter service life.• To avoid entrance of vermin, the drain outlet(s) on the right and/or left under the food mounts must always be filled with the plug(s) provided.	

IMPORTANT

- The showcase is intended to display sushi materials and keep them cool during business hours. The showcase contains a large amount of glass and provides less refrigeration and cold storage capacity than ordinary refrigerators. Before displaying sushi materials, allow the showcase to operate for about 1 hour to cool down. Fully refrigerate sushi materials in a refrigerator prior to displaying them in the showcase.
- During operation, moisture inside the showcase causes frost to build up on the evaporator pipe inside. Frost has an insulating effect on the evaporator pipe and reduces refrigeration performance. Every time the door is opened, warm and humid air comes in and raises the interior temperature to accelerate frost formation. Opening of the doors should be kept to a minimum to maintain proper operating temperatures. Do not leave the doors open continuously.
Since frost on the evaporator pipe reduces refrigeration performance, the showcase cannot be used continuously. After business hours, return sushi materials to a refrigerator and turn off the showcase.
Leave the showcase off for at least 1 to 2 hours to defrost. Failure to defrost the showcase will result in improper operating temperatures.
In some conditions, frost may build up in a short time and reduce cooling performance. In these conditions, defrost the showcase as needed during the day. While defrosting the showcase, move sushi materials to a refrigerator to prevent deterioration.
- It is normal to find condensation on the showcase in a humid or rainy weather. Simply wipe it off with a soft cloth from time to time.
- Control the food temperature by placing the food mounts as follows:

Normal condition or
when food temp. is too low

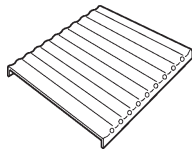

For more intensive cooling

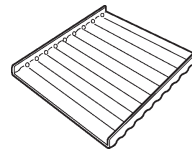

- The maximum safe height for displaying food products is 3.5" (9cm) above the interior bottom. Food products should not be placed above this height as they may not remain cold enough to avoid spoilage.
- If the showcase is turned off, wait for at least 3 minutes before restarting the showcase. Otherwise the overload protector may operate and allow defrost water to drip onto the items inside. The overload protector will reset automatically in 30 minutes.

1) Clean inside the showcase.

2) Plug in the showcase, and turn on the power switch.

* When not in use, dry the showcase thoroughly and store it in a dry place.

III. Maintenance and Cleaning Instructions

⚠ WARNING

Before carrying out any cleaning or maintenance operations, unplug the showcase.
--

⚠ AVERTISSEMENT

Avant toute opération de maintenance ou de nettoyage, débranchez la vitrine.
--

NOTICE

- | |
|---|
| <ul style="list-style-type: none">• Do not disassemble the showcase further than illustrated in Fig. 1.• Do not touch or wet the machine compartment parts. This could result in failure or breakdown. |
|---|

A. Interior/Exterior

- * Clean the interior and food mounts every day for sanitary use.
- * Use a soft cloth soaked in warm water to clean off the exterior. Do not use a water jet to clean the exterior.
- * Use only a neutral cleaner. Other chemical agents might cause damage to the interior and exterior surfaces.

Note: To prevent damage to the part surfaces, do not use a scourer on the interior/exterior surfaces.

B. Drain Pipe Cleaning

- 1) Either mix 0.26 gal. (1 liter) of water with 0.13 fl. oz. (3.7 ml) of 5.25% sodium hypochlorite solution in a suitable container, or the recommended Hoshizaki sanitizer as directed.
- 2) Disconnect the hose from the joint.
- 3) Turn up the end of the joint(s).
- 4) Slowly pour the sanitizing solution into the drain water circuit from the joint(s).
- 5) Wait for 5 minutes, and turn down the end of the joint(s) to drain the solution.
- 6) Leave the drain water circuit to dry out.

C. Air Filter

A plastic mesh air filter removes dirt or dust from the air, and keeps the condenser from getting clogged. If the filter gets clogged, the showcase's performance will be reduced. Check the filter at least twice a month. When clogged, use warm water and a neutral cleaner to wash the filter.

- 1) Hold the tabs located at the bottom of the louver, and lift them up to release the louver from the body.
- 2) Pull the louver toward you.
- 3) Pull the louver downward.
- 4) Grasp the frame of the air filter, and pull it toward you.
- 5) Clean the air filter.
- 6) Refit the air filter and louver in the reverse order of the removal procedure.

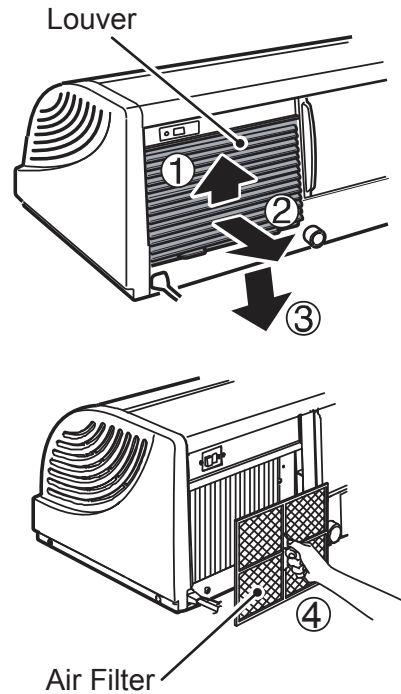

Fig. 6

D. Condenser

Check the condenser once a year, and clean if required by using a brush or vacuum cleaner. More frequent cleaning may be required depending on the location of the showcase.

E. Checking Ground Fault Circuit Interrupter

Push the test button at least once a month, and simulate a ground fault on the load circuit.

HOSHIZAKI AMERICA, INC.

618 Hwy. 74 South, Peachtree City, GA 30269 USA (P) 770.487.2331 (F) 770.487.3360 hoshizakiamerica.com L1S014102