



# HOSHIZAKI

## Service Manual

Self-Contained Cuber

Model

IM-50BAA-Q



[hoshizakiamerica.com](http://hoshizakiamerica.com)

Number: M041-1092  
Issued: 05-01-2020

**⚠ WARNING**

Only qualified service technicians should install and service the icemaker. To obtain the name and phone number of your local Hoshizaki Certified Service Representative, visit [www.hoshizaki.com](http://www.hoshizaki.com). No service should be undertaken until the technician has thoroughly read this Service Manual. Failure to service and maintain the appliance in accordance with this manual will adversely affect safety, performance, component life, and warranty coverage and may result in costly water damage. Proper installation is the responsibility of the installer. Product failure or property damage due to improper installation is not covered under warranty.

Hoshizaki provides this manual primarily to assist qualified service technicians in the maintenance and service of the product.

Should the reader have any questions or concerns which have not been satisfactorily addressed, please call, write, or send an e-mail message to the Hoshizaki Technical Support Department for assistance.

Phone: 1-800-233-1940; (770) 487-2331  
Fax: 1-800-843-1056; (770) 487-3360

E-mail: [techsupport@hoshizaki.com](mailto:techsupport@hoshizaki.com)

**HOSHIZAKI AMERICA, INC.**

618 Highway 74 South  
Peachtree City, GA 30269  
Attn: Hoshizaki Technical Support Department

Web Site: [www.hoshizaki.com](http://www.hoshizaki.com)

**NOTE:** To expedite assistance, all correspondence/communication **MUST** include the following information:

- Model Number \_\_\_\_\_
- Serial Number \_\_\_\_\_
- Complete and detailed explanation of the problem..

## **IMPORTANT**

This manual should be read carefully before the appliance is serviced. Read the warnings and guidelines contained in this manual carefully as they provide essential information for the continued safe use, service, and maintenance of the appliance. Retain this manual for any further reference that may be necessary.

## **CONTENTS**

Important Safety Information .....	4
I. Construction and Water/Refrigeration Circuit Diagram .....	6
A. Construction.....	6
B. Water/Refrigeration Circuit Diagram .....	8
II. Sequence of Operation and Service Diagnosis.....	9
A. Sequence of Operation Flow Chart .....	9
B. Sequence of Operation.....	10
1. Startup Cycle.....	10
2. Harvest Cycle.....	10
3. Freeze Cycle .....	10
4. Shutdown .....	10
C. Service Diagnosis Table .....	12
D. Bin Control Check and Cleaning .....	14
1. Bin Control Check .....	14
2. Bin Control Cleaning .....	15
E. Evaporator Thermistor Check.....	16
III. Controls and Adjustments.....	17
A. Control Switch.....	17
B. Control Board.....	17
1. Control Board Layout .....	18
C. Control Buttons.....	19
1. RESET Button .....	19
2. SERVICE 1 and SERVICE 2 Buttons.....	19
D. Control Board Settings .....	20
E. Control Board Information Display.....	25
F. Control Board Model Code Setting.....	26
1. Control Board Replacement.....	26
G. Error Codes .....	26
1. Error Codes.....	26
2. Service Diagnosis.....	28
IV. Refrigeration Circuit and Component Service Information .....	29
A. Refrigeration Circuit Service Information .....	29
1. Refrigerant Recovery .....	29
2. Brazing .....	30
3. Evacuation and Recharge (R-134a).....	30
B. Component Service Information .....	31
1. Cabinet.....	31
[a] Top Panel, Top Insulation, Top Cover .....	31
[b] Front Frame, Drain Pan .....	32

[c] Front Panel (Lower) .....	32
[d] Rear Panel .....	32
[e] Door Assembly, Slope, Spring .....	32
2. Refrigeration Circuit.....	33
[a] Compressor .....	33
[b] Condenser .....	34
[c] Hot Gas Valve .....	34
[d] Upper Evaporator .....	35
[e] Fan Motor .....	38
3. Icemaking Mechanism.....	39
[a] Actuator Motor Assembly .....	39
[b] Cam Shaft Assembly .....	39
[c] Water Plate Switch.....	40
[d] Cam Switch.....	40
[e] Water Tank Assembly .....	40
[f] Lower Evaporator .....	40
[g] Evaporator Base .....	40
[h] Pump Motor .....	40
[i] Water Tank .....	40
[j] Ice Guide.....	43
V. Maintenance .....	45
VI. Preparing the Appliance for Periods of Non-Use .....	46
VII. Disposal .....	48
VIII. Technical Information .....	49
A. Specification Data .....	49
B. Performance Data.....	50
C. Wiring Diagram.....	51

## Important Safety Information

Throughout this manual, notices appear to bring your attention to situations which could result in death, serious injury, damage to the appliance, or damage to property.

**⚠ WARNING** Indicates a hazardous situation which could result in death or serious injury.

**NOTICE** Indicates a situation which could result in damage to the appliance or property.

**IMPORTANT** Indicates important information about the installation, use, and care of the appliance.

### ⚠ WARNING

The appliance should be destined only to the use for which it has been expressly conceived. Any other use should be considered improper and therefore dangerous. The manufacturer cannot be held responsible for injury or damage resulting from improper, incorrect, and unreasonable use. Failure to service and maintain the appliance in accordance with this manual will adversely affect safety, performance, component life, and warranty coverage and may result in costly water damage.

**To reduce the risk of death, electric shock, serious injury, or fire, follow basic precautions including the following:**

- Only qualified service technicians should install and service the appliance.
- The appliance must be installed in accordance with applicable national, state, and local codes and regulations.
- The appliance requires an independent power supply of proper capacity. See the nameplate for electrical specifications. Failure to use an independent power supply of proper capacity can result in a tripped breaker, blown fuse, damage to existing wiring, or component failure. This could lead to heat generation or fire.
- **THE APPLIANCE MUST BE GROUNDED:** The appliance is equipped with a NEMA 5-15 three-prong grounding plug to reduce the risk of potential shock hazards. It must be plugged into a properly grounded, independent 3-prong wall outlet. If the outlet is a 2-prong outlet, it is your personal responsibility to have a qualified electrician replace it with a properly grounded, independent 3-prong wall outlet. Do not remove the ground prong from the plug and do not use an adapter plug. Failure to properly ground the appliance could result in death or serious injury.
- Do not use an extension cord.
- To reduce the risk of electric shock, do not touch the control switch or plug with damp hands. Make sure the control switch is in the "OFF" position before plugging in or unplugging the appliance.
- Do not use an appliance with a damaged power cord. The power cord should not be altered, jerked, bundled, weighed down, pinched, or tangled. Such actions could result in electric shock or fire. To unplug the appliance, be sure to pull the plug, not the cord, and do not jerk the cord.
- Do not make any alterations to the appliance. Alterations could result in electric shock, injury, fire, or damage to the appliance.

### **⚠ WARNING, continued**

- The appliance is not intended for use by persons (including children) with reduced physical, sensory, or mental capabilities, or lack of experience and knowledge, unless they have been given supervision or instruction concerning use of the appliance by a person responsible for their safety.
- Young children should be properly supervised around the appliance.
- Do not climb, stand, or hang on the appliance or appliance door or allow children or animals to do so. Serious injury could occur or the appliance could be damaged.
- Be careful not to pinch fingers when opening and closing the door. Be careful when opening and closing the door when children are in the area.
- Do not use combustible spray or place volatile or flammable substances near the appliance. They might catch fire.
- Keep the area around the appliance clean. Dirt, dust, or insects in the appliance could cause harm to individuals or damage to the appliance.

### **NOTICE**

- Protect the floor when moving the appliance to prevent damage to the floor.
- Follow the water supply, drain connection, and maintenance instructions carefully to reduce the risk of costly water damage.
- In areas where water damage is a concern, install in a contained area with a floor drain.
- Install the appliance in a location that stays above freezing. Normal operating ambient temperature must be within 45°F to 100°F (7°C to 38°C).
- If water collects in the bin and will not drain, turn off the appliance and close the water supply line shut-off valve. Locate and resolve the issue.
- Do not leave the appliance on during extended periods of non-use, extended absences, or in sub-freezing temperatures. To properly prepare the appliance for these occasions, follow the instructions in "VI. Preparing the Appliance for Periods of Non-Use."
- Keep ventilation openings, in the appliance enclosure or in the built-in structure, clear of obstruction.
- Do not place more than 33 lb. (15 kg) on the top panel.
- The storage bin is for ice use only. Do not store anything else in the storage bin.

# I. Construction and Water/Refrigeration Circuit Diagram

## A. Construction

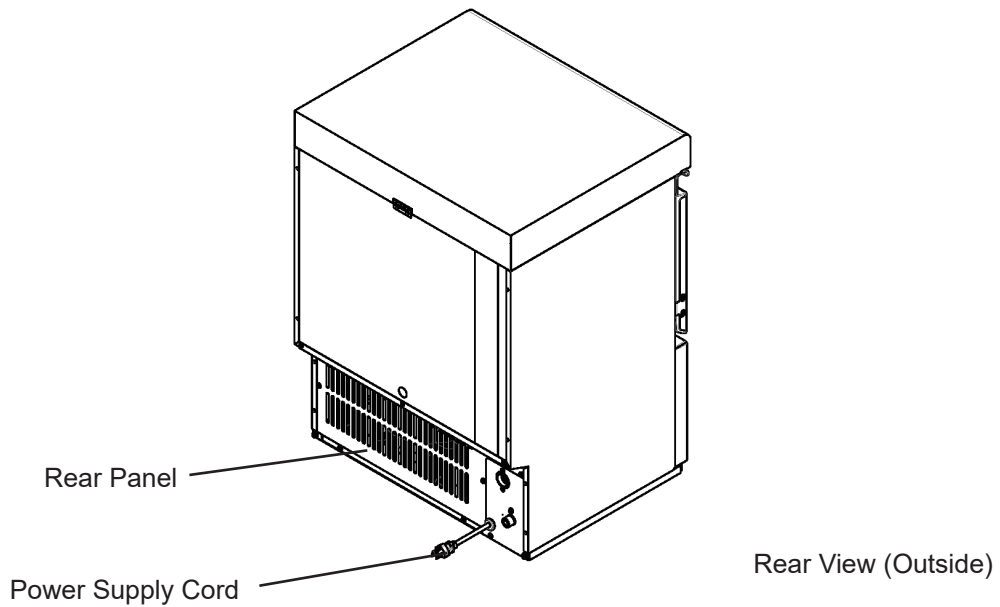
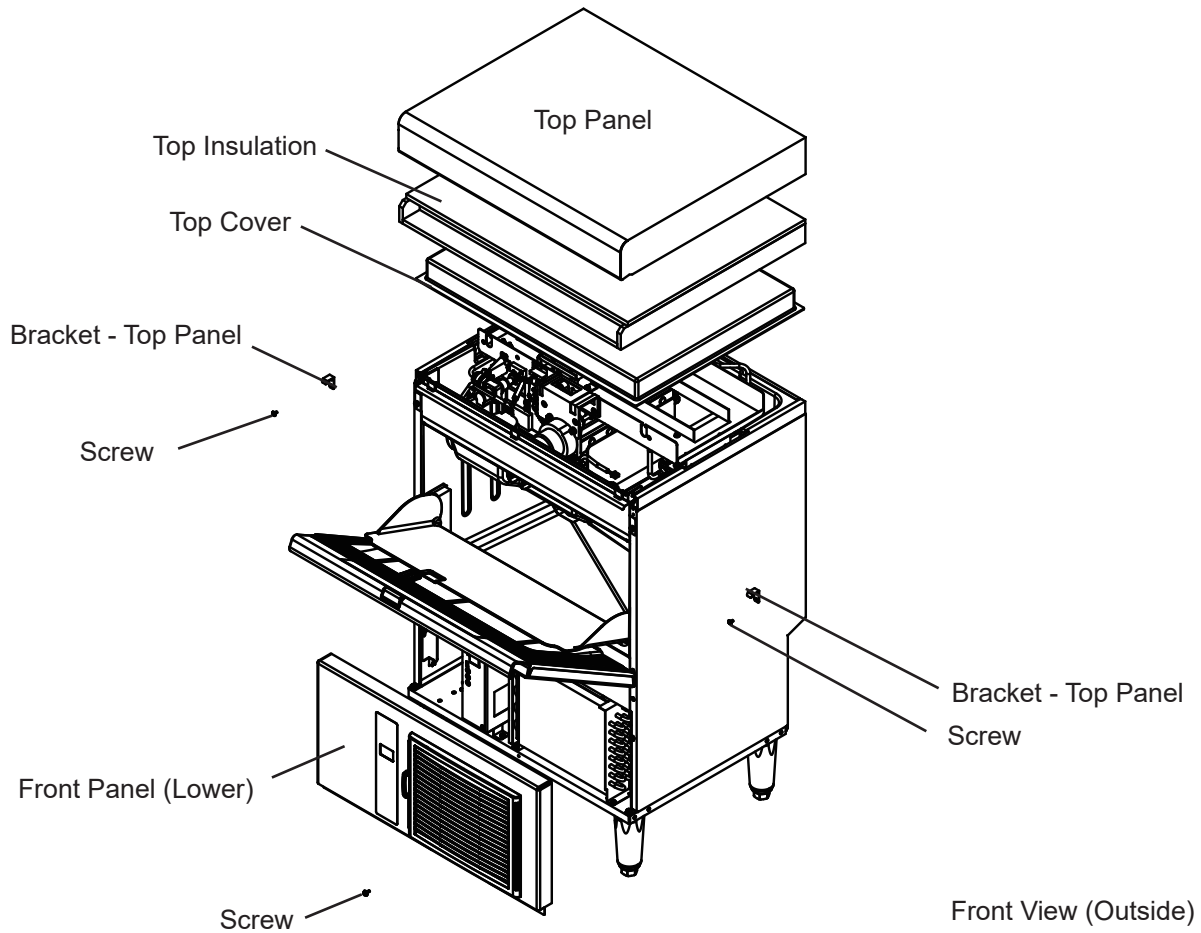

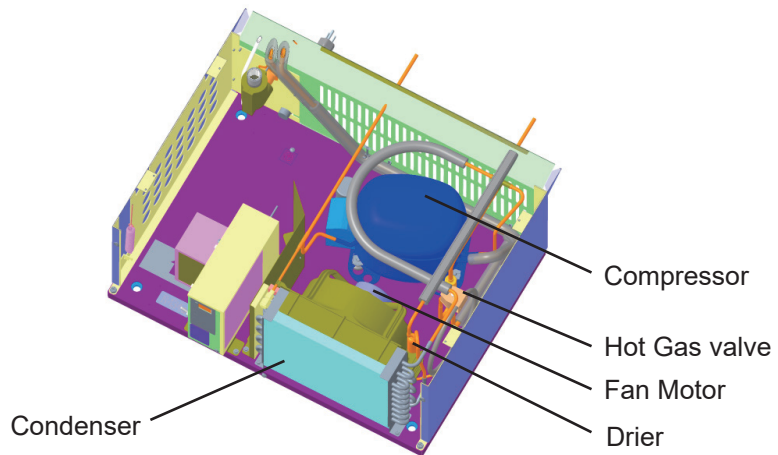
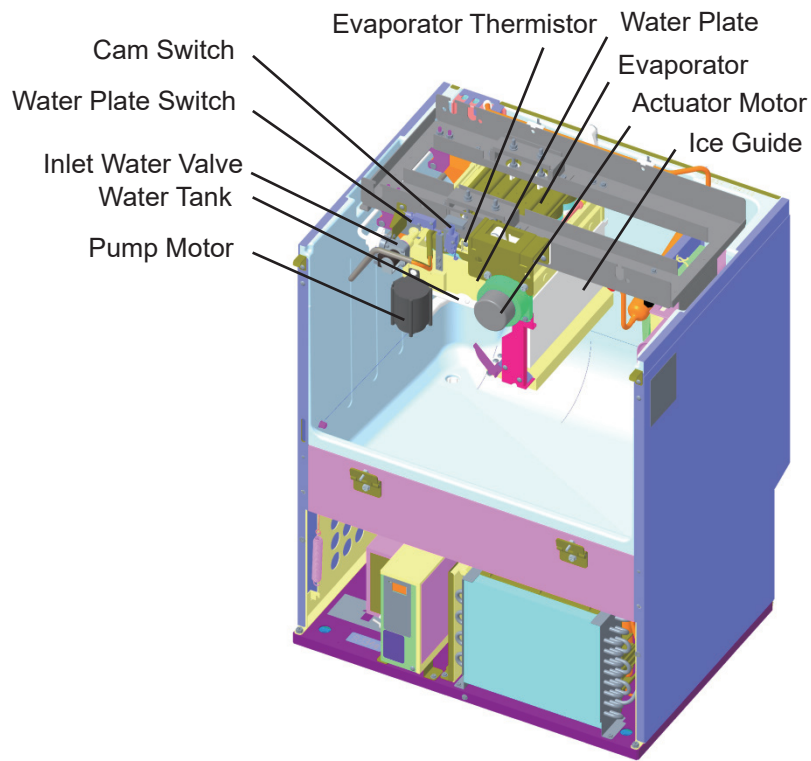
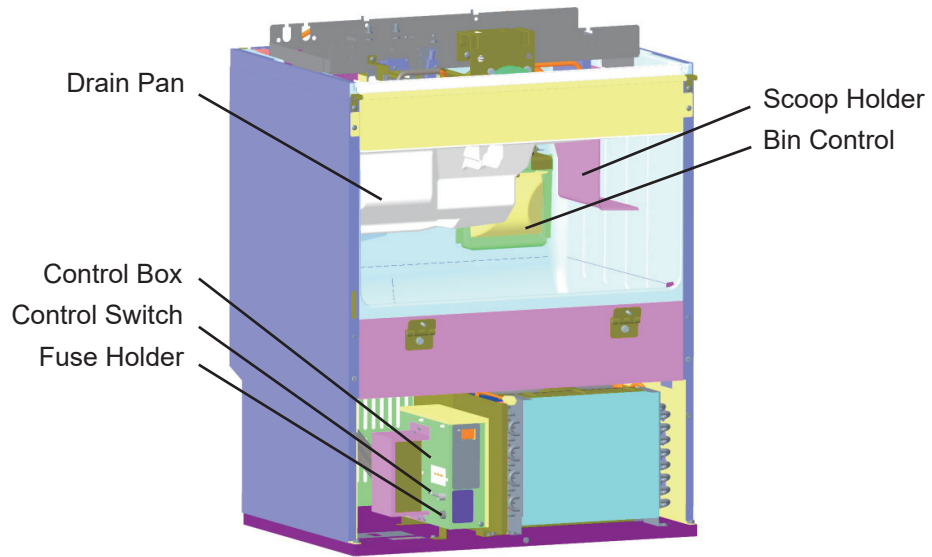

## B. Water/Refrigeration Circuit Diagram

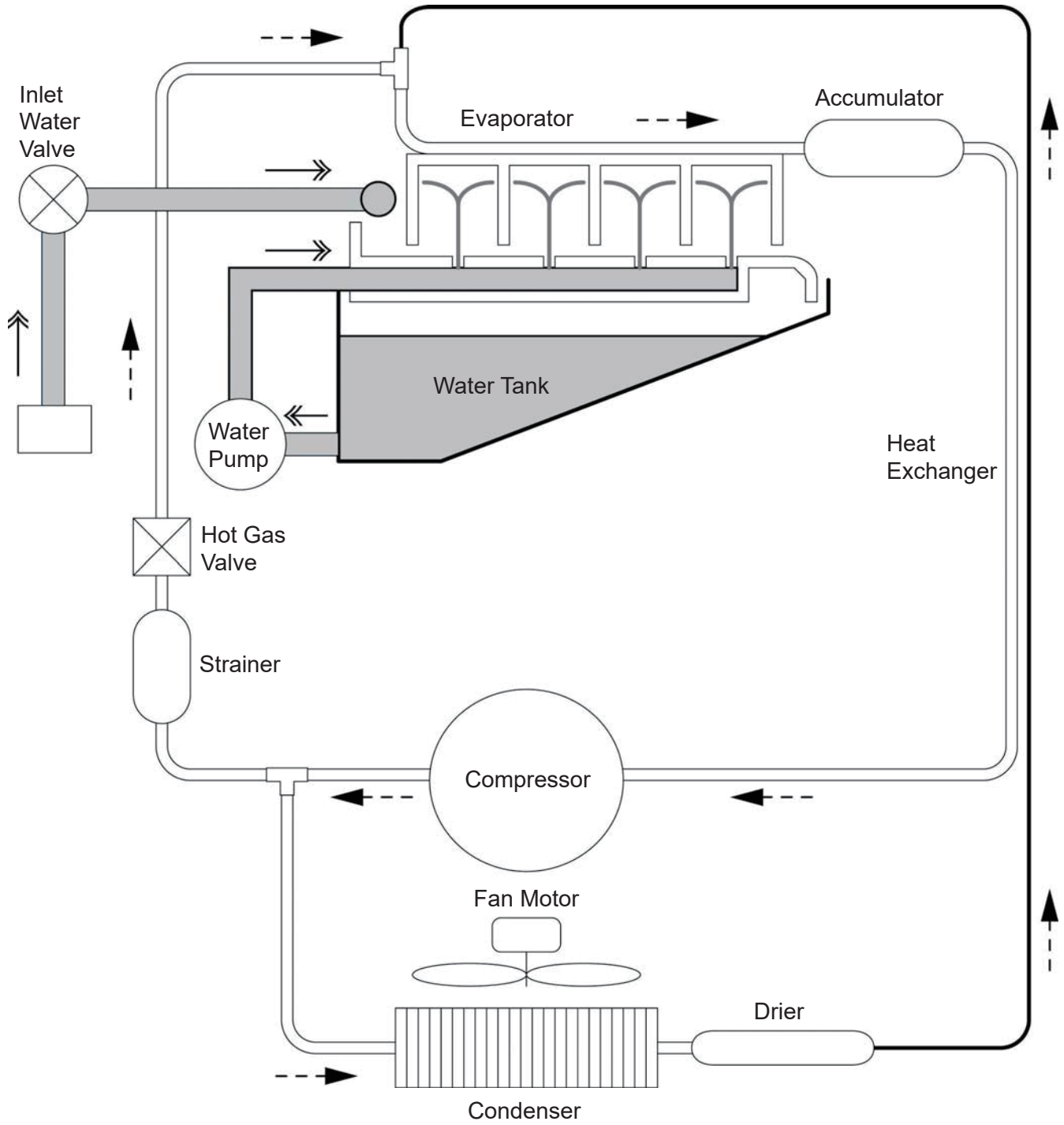

## II. Sequence of Operation and Service Diagnosis

### A. Sequence of Operation Flow Chart

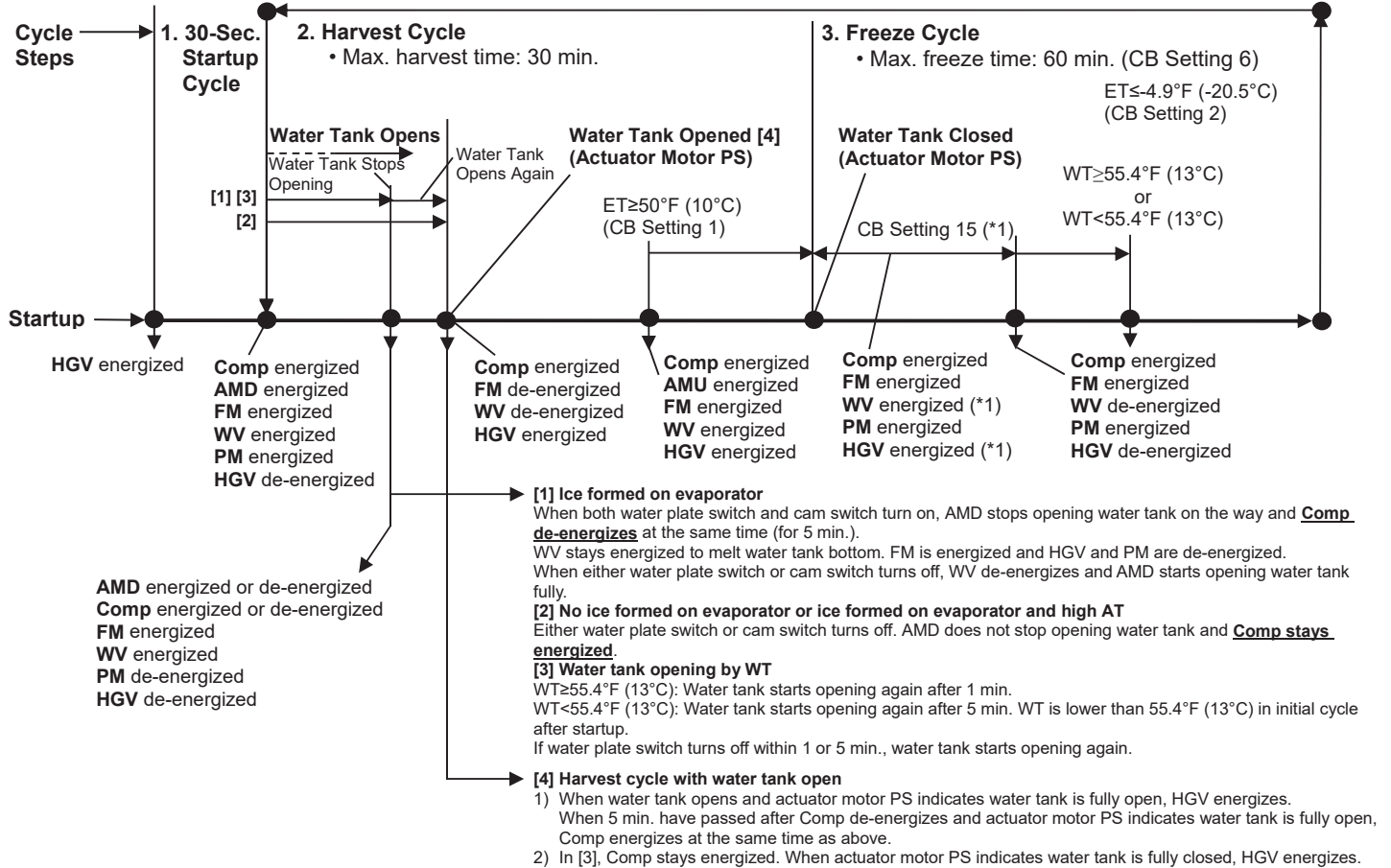

### Shutdown and Restart Sequence Flow Chart

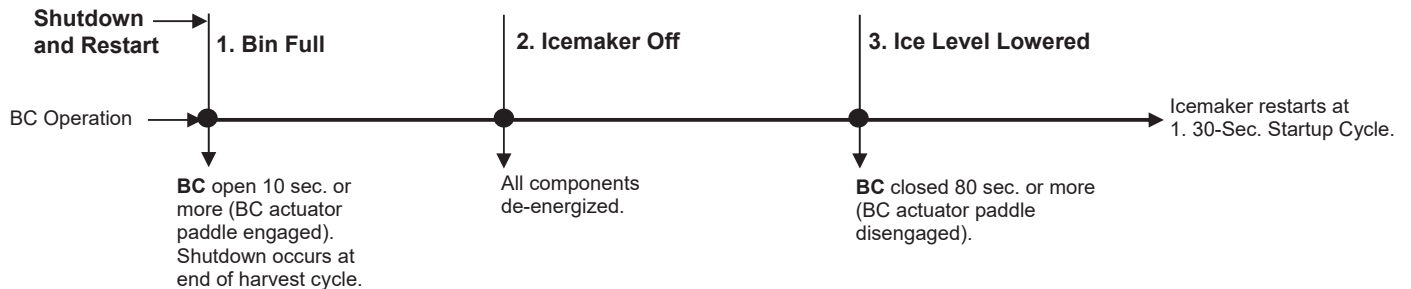

**Legend:**

**AMD**—actuator motor down  
**AMU**—actuator motor up  
**AT**—ambient temperature  
**BC**—bin control  
**CBT**—control board thermistor  
**Comp**—compressor  
**ET**—evaporator thermistor  
**FM**—fan motor  
**HGV**—hot gas valve  
**PM**—pump motor  
**PS**—position sensor  
**WT**—water temperature  
**WV**—inlet water valve

## B. Sequence of Operation

### 1. Startup Cycle

When power supply is turned on, "on" appears on CB display and HGV energizes. 30 sec. later, harvest cycle starts.

- If the "RESET" button is pressed during 30-sec. startup cycle time, startup cycle ends immediately and harvest cycle starts.

### 2. Harvest Cycle

See the timing chart on next page.

### 3. Freeze Cycle

See the timing chart on next page.

### 4. Shutdown

When BC is engaged (open) for more than 10 seconds, the icemaker shuts down after harvest cycle.

When BC is disengaged (closed) for more than 80 seconds, icemaker restarts at startup cycle.

If BC is engaged (open) while the water tank is opening after the power supply is turned on (or after the "RESET" button is pressed), shutdown does not start: Shutdown occurs 10 seconds after actuator motor's internal position sensor indicates water tank is fully open.

For details, see the timing chart on next page.

Legend: **BC**—bin control; **CB**—control board; **HGV**—hot gas valve

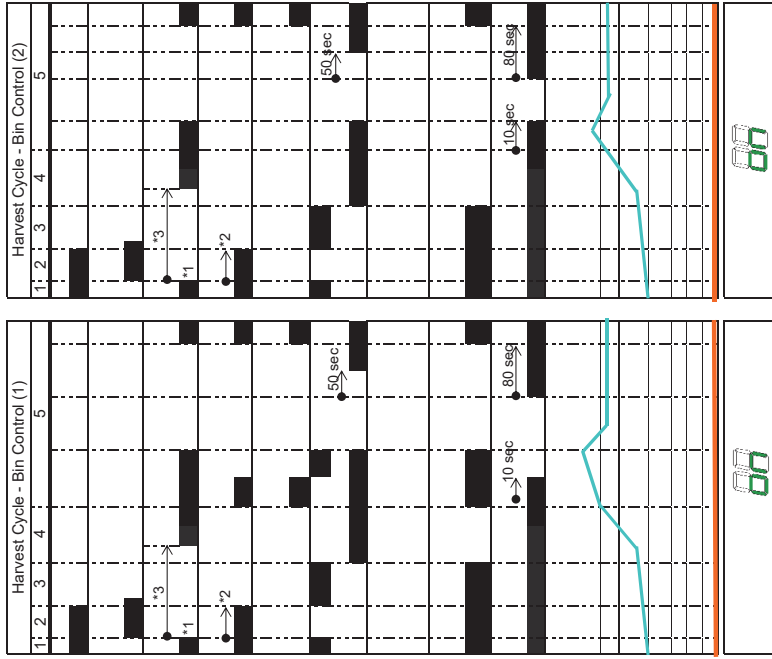
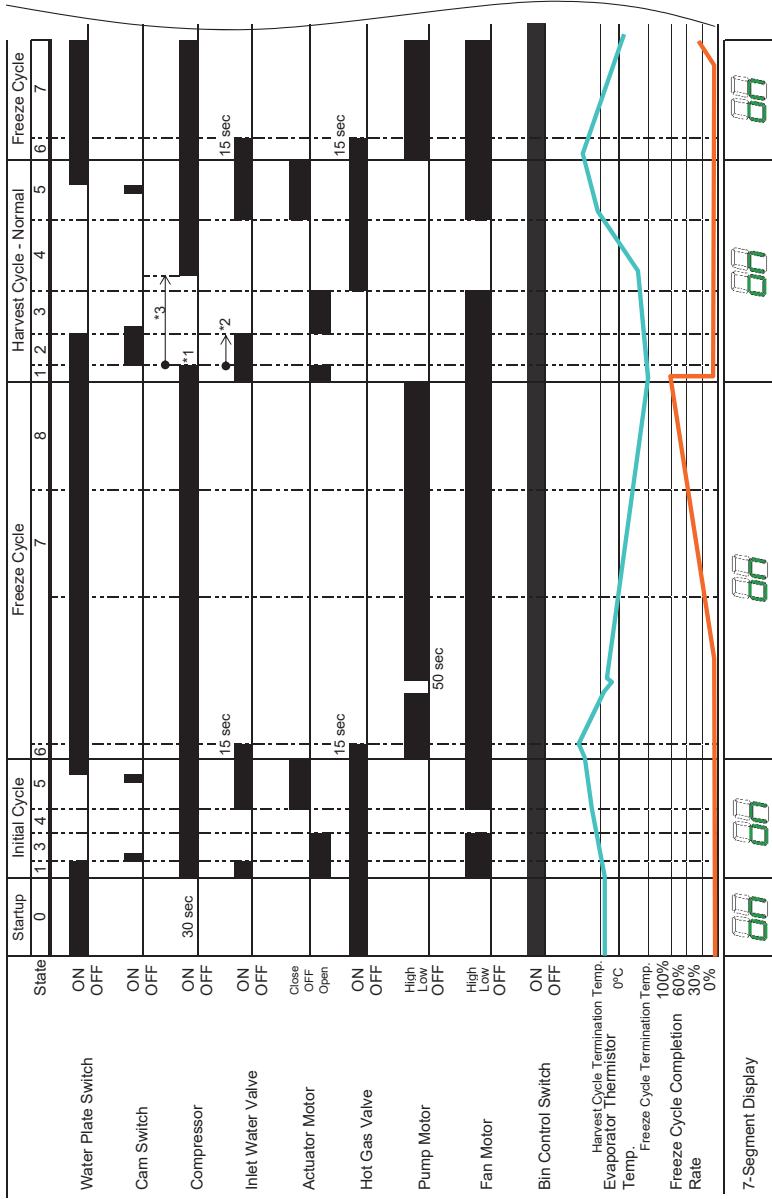

Operation

- State 0 When power supply is turned on at startup, hot gas valve energizes. After 30 seconds, State 1 starts.
- State 1 After compressor energizes at startup or freeze cycle ends, water tank opens until cam switch detects cam location while water is supplied for harvest cycle. If evaporator has no ice, water plate switch turns off, compressor keeps running, and water tank fully opens.
  - \* The above operation is also made at high ambient temperatures where ice is easy to harvest.
- State 2 If freeze cycle ends and evaporator has ice, water tank opens until cam switch detects cam location, but water plate does not separate, and actuator motor and compressor de-energize (\*1).
- State 3 When water plate switch turns off, inlet water valve de-energizes and water tank starts to open again.
  - If water temperature is 13°C or higher, water tank starts to open again in 1 minute (\*2).
  - If water temperature is lower than 13°C, water tank starts to open again in 5 minutes (\*2). -- Water temperature is lower than 13°C in initial cycle after startup. However, if water plate switch turns off within 1 or 5 minute(s), water tank starts to open again.
  - \* When water plate switch or cam switch turns off, water tank starts to open again.
- State 4 When water tank opens and actuator motor's internal position sensor indicates water tank is fully open, hot gas valve energizes. When 5 minutes have passed after compressor de-energizes in State 2 and actuator motor's internal position sensor indicates water tank is fully open, compressor energizes (\*3).
- State 5 When evaporator thermistor temperature reaches harvest cycle termination temperature, water tank starts to close and inlet water valve energizes to start water supply. Fan motor energizes at the same time.
- State 6 When water tank closes and actuator motor's internal position sensor indicates water tank is fully closed, pump motor energizes, and inlet water valve and hot gas valve energizes for 15 seconds.
- State 7 After 15 seconds, inlet water valve and hot gas valve de-energizes to start freeze cycle.
- State 8 When evaporator thermistor reaches target integrated value, State 1 starts (see details).

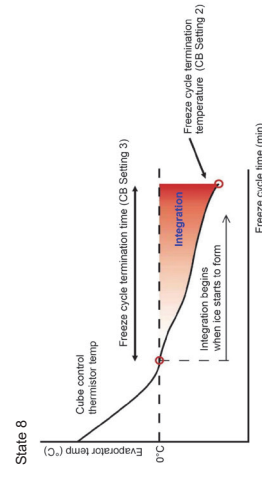

- 1) Target integrated value for freeze cycle termination is determined by CB Settings 2 and 3.
- 2) After evaporator thermistor senses 0°C, freeze cycle termination temperature and freeze cycle termination time are integrated every second.
- 3) When target integrated value is reached, freeze cycle ends.

Harvest Cycle - Bin Control (1): Bin control while water tank is closing  
 Bin control trips while water tank is closing. After 10 seconds, water tank starts to open again, and actuator motor's internal position sensor indicates water tank is fully open. Then, icemaker shuts down.  
 State 5 When bin control is ON for 10 seconds, inlet water valve de-energizes. Then, after water tank fully opens, compressor and hot gas valve de-energize.  
 When bin control is ON for 50 seconds, hot gas valve energizes. When bin control is ON for 80 seconds, State 5 in harvest cycle - normal starts followed by freeze cycle.

Harvest Cycle - Bin Control (2): Bin control after water tank opens  
 State 5 Water tank opens and actuator motor's internal position sensor indicates water tank is fully open. When bin control trips, water tank does not close even if harvest cycle termination temperature is reached.  
 After 10 seconds, icemaker shuts down.  
 When bin control is ON for 50 seconds, hot gas valve energizes. When bin control is ON for 80 seconds, State 5 in harvest cycle - normal starts followed by freeze cycle.

## C. Service Diagnosis Table

First see "III.G. Error Codes." If there are no recorded errors, refer to the table below.

<b>No Ice Production - Possible Cause</b>	
1. Power Supply	a) Off, blown fuse, or tripped breaker.
	b) Not within specifications.
2. Fuse (Control Box)	a) Blown.
3. Control Switch	a) In "OFF" or "WASH" position.
	b) Bad contacts.
4. Control Board	a) Error. See "III.G. Error Codes."
	b) Defective.
5. Bin Control See "II.D. Bin Control Check and Cleaning"	a) Tripped with bin filled with ice.
	b) Actuator does not move freely.
	c) Defective.
6. Water Supply	a) Water supply off or improper water pressure.
	b) External water filters restricted.
7. Inlet Water Valve	a) Screen or orifice restricted.
	b) Coil winding open.
8. Compressor	a) Compressor relay/magnetic contactor contacts bad or coil winding open.
	b) Start capacitor or run capacitor defective (single phase).
	c) Internal protector open.
	d) Start relay contacts bad or coil winding open (single phase).
	e) Defective.
9. Hot Gas Valve	a) Defective.
10. Evaporator (Cube Control) Thermistor See "II.E. Evaporator Thermistor Check"	a) Loose, disconnected, or defective.
11. Pump Motor	a) Defective.
12. Thermostatic Expansion Valve	a) Bulb loose.
	b) Defective.
13. Fan Motor	a) Defective.
14. Water System	a) Water leaks.
<b>Low Ice Production - Possible Cause</b>	
<b>Long Harvest Cycle</b>	
1. Evaporator	a) Scaled up.
2. Refrigerant Charge	a) Low.
3. Control Board	a) Thermistor connection loose (K3).
	b) Defective.
4. Evaporator (Cube Control) Thermistor See "II.E. Evaporator Thermistor Check"	a) Loose, disconnected, or defective.
5. Hot Gas Valve	a) Erratic or closed.
6. Compressor	a) Inefficient or off.

<b>Long Freeze Cycle</b>	
1. Evaporator	a) Scaled up, dirty.
2. Hot Gas Valve	a) Defective.
3. Condenser	a) Restricted.
4. Control Board	a) Defective.
5. Refrigerant Charge	a) Low.
6. Compressor	a) Inefficient or off.
<b>Slab Does Not Break Into Separate Cubes - Possible Cause</b>	
1. Spring	a) Over-extended.
2. Water Plate	a) Obstacle caught between evaporator and water plate.
<b>Cubes Drop Separately - Possible Cause</b>	
1. Refrigerant Charge	a) Low - Long harvest cycle.
2. Cam Arm	a) Worn out.
<b>Imperfect Ice Production - Possible Cause</b>	
1. Water Supply	a) Improper water pressure.
	b) External water filters restricted.
	c) Water leaks from water tank or water plate due to broken tank or plate or icemaker out of level.
2. Inlet Water Valve	a) Water leaks from valve body or water supply pipe joint.
3. Water Plate	a) Spray holes restricted.
4. Pump Motor	a) Defective.
<b>Large-Hole Cubes - Possible Cause</b>	
1. Refrigerant Charge	a) Low.
2. Condenser	a) Dirty condenser or air filter.
3. Fan Motor	a) Defective.
4. Icemaker Location	a) Insufficient clearance.
	b) Ambient temperature too high.
5. Water Supply	a) Water leaks.
	b) Improper water pressure.
<b>Cloudy Cubes - Possible Cause</b>	
1. Water Quality	a) High hardness.
2. Slush Ice	a) Use Anti-Slush Control (Control Board Settings 50 and 51).

## D. Bin Control Check and Cleaning

### 1. Bin Control Check

This appliance uses a lever-actuated proximity switch to control the ice level in the storage bin. No adjustment is required.

To check, follow the steps below.

- 1) Remove the front panel and then move the control switch to the "OFF" position.
- 2) Unplug the appliance.
- 3) Remove the control box cover. Clear any ice away from BC.
- 4) Check BC wire harness connections.
- 5) Disconnect BC wire harness connector from CB CN3 connector.
- 6) Check for continuity across the wires of BC wire harness connector. When the actuator paddle is not engaged, BC switch is closed. If open, check that the wire harness connector is properly connected and that the actuator paddle is not sticking. Clean if necessary. See "II.D.2. Bin Control Cleaning." If BC switch still reads open, replace BC.
- 7) Press and hold the actuator paddle; check for continuity across the wires of BC wire harness connector. When the actuator paddle is engaged, BC switch is open. If closed, check that the actuator paddle is not restricted. Clean if necessary. See "II.D.2. Bin Control Cleaning." If BC switch still reads closed, replace BC.
- 8) Reconnect BC wire harness connector to CB CN3 connector, then move the control switch to the "ICE" position. Turn on the power supply.
- 9) Allow the icemaker to cycle on. Press and hold the actuator paddle for at least 10 seconds. The icemaker should shut down. If it does not, replace CB.

Note: If BC is engaged (open) while the water tank is opening after the power supply is turned on (or after the "RESET" button is pressed), shutdown does not start: Shutdown occurs 10 seconds after actuator motor's internal position sensor indicates water tank is fully open.

Legend: **BC**—bin control; **CB**—control board

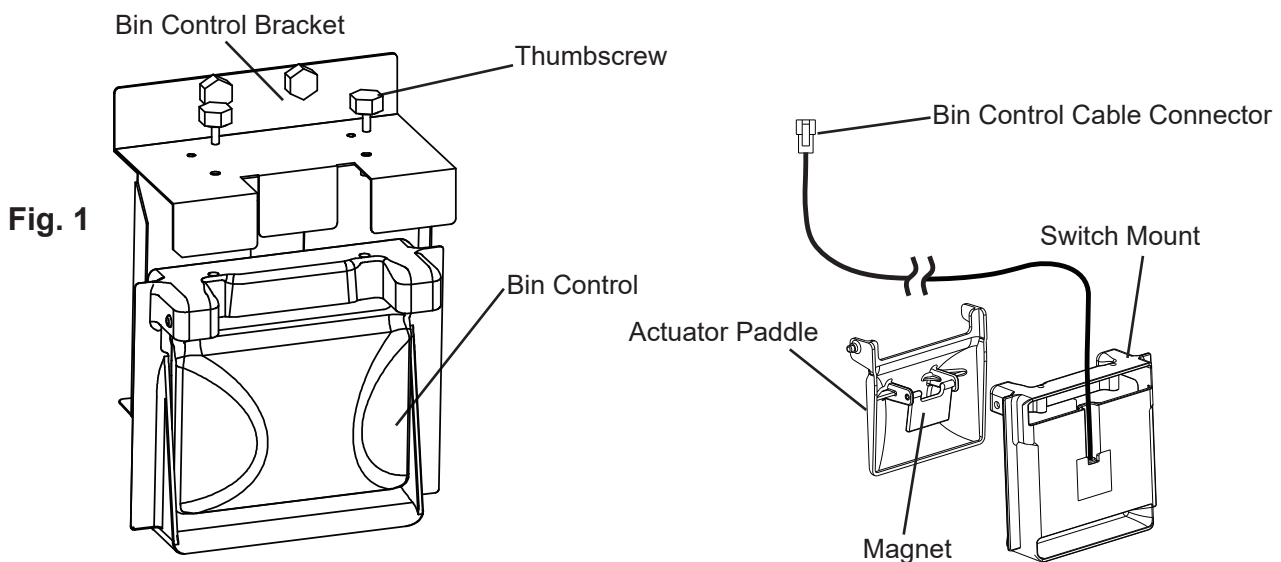

## 2. Bin Control Cleaning

Scale may build up on BC. Scale can cause the actuator paddle and magnet to stick. In this case, BC should be cleaned.

### **WARNING**

**CHOKING HAZARD:** Ensure all components, fasteners, and thumbscrews are securely in place after the icemaker is serviced. Make sure that none have fallen into the dispense unit/ice storage bin.

- 1) Remove the front panel and then move the control switch to the "OFF" position. Unplug the appliance.
- 2) Remove the top panel, top insulation, and top sheet.
- 3) Clear any ice away from BC.
- 4) Carefully remove the BC cable from the cable ties in the evaporator case, then remove the BC from the bin control bracket and move to the front of the icemaker for cleaning.
- 5) Remove the actuator paddle from the switch mount. See Fig. 1.
- 6) Wipe down BC with a mixture of 1 part of Hoshizaki "Scale Away" and 25 parts of warm water. Rinse the parts thoroughly with clean water.
- 7) Reassemble BC and replace it in its correct position.  
Note: If the magnet was removed for cleaning, be sure to replace it in its correct position.
- 8) Replace the BC cable into the cable ties in the evaporator case, then replace the top sheet, top insulation, and top panel.
- 9) Confirm CB wire harness connections are secure, then replace the control box cover in its correct position.
- 10) Plug in the appliance. Move the control switch to the "ICE" position.
- 11) Replace the front panel in its correct position.

Legend: **BC**—bin control; **CB**—control board

## E. Evaporator Thermistor Check

To check thermistor resistance, follow the steps below.

- 1) Remove the front panel and then move the control switch to the "OFF" position.
- 2) Unplug the appliance.
- 3) Remove the control box cover.
- 4) Remove the thermistor from the evaporator.
- 5) Immerse the thermistor sensor portion in a glass containing ice and water for 2 or 3 min.
- 6) Disconnect the thermistor connector from CB CN13 connector and check the resistance between thermistor leads. Normal range is 4.7 to 6.2 k $\Omega$ . If outside the normal range, replace the thermistor. If within the normal range, continue to the next step.
- 7) Replace the thermistor in its correct position.
- 8) Reconnect the thermistor connector to CB CN13 connector.
- 9) Replace the control box cover in its correct position.
- 10) Plug in the appliance.
- 11) Move the control switch to the "ICE" position.
- 12) Replace the front panel.

Legend: **CB**—control board

---

### III. Controls and Adjustments

#### A. Control Switch

The control switch has three positions: OFF for power off, ICE for icemaking, and WASH to energize the water pump when cleaning and sanitizing.

#### B. Control Board

- A Hoshizaki exclusive control board is employed in IM series appliances.
- All models are pretested and factory adjusted.

<b><i>NOTICE</i></b>
<ul style="list-style-type: none"><li>• Fragile, handle very carefully.</li><li>• The control board contains integrated circuits, which are susceptible to failure due to static discharge. It is especially important to touch the metal part of the icemaker when handling or replacing the control board.</li><li>• Do not touch the electronic devices on the control board or the back of the control board.</li><li>• Do not change wiring and connections.</li><li>• Do not short out power supply to test for voltage.</li><li>• Always replace the whole control board assembly if it goes bad.</li></ul>

# 1. Control Board Layout

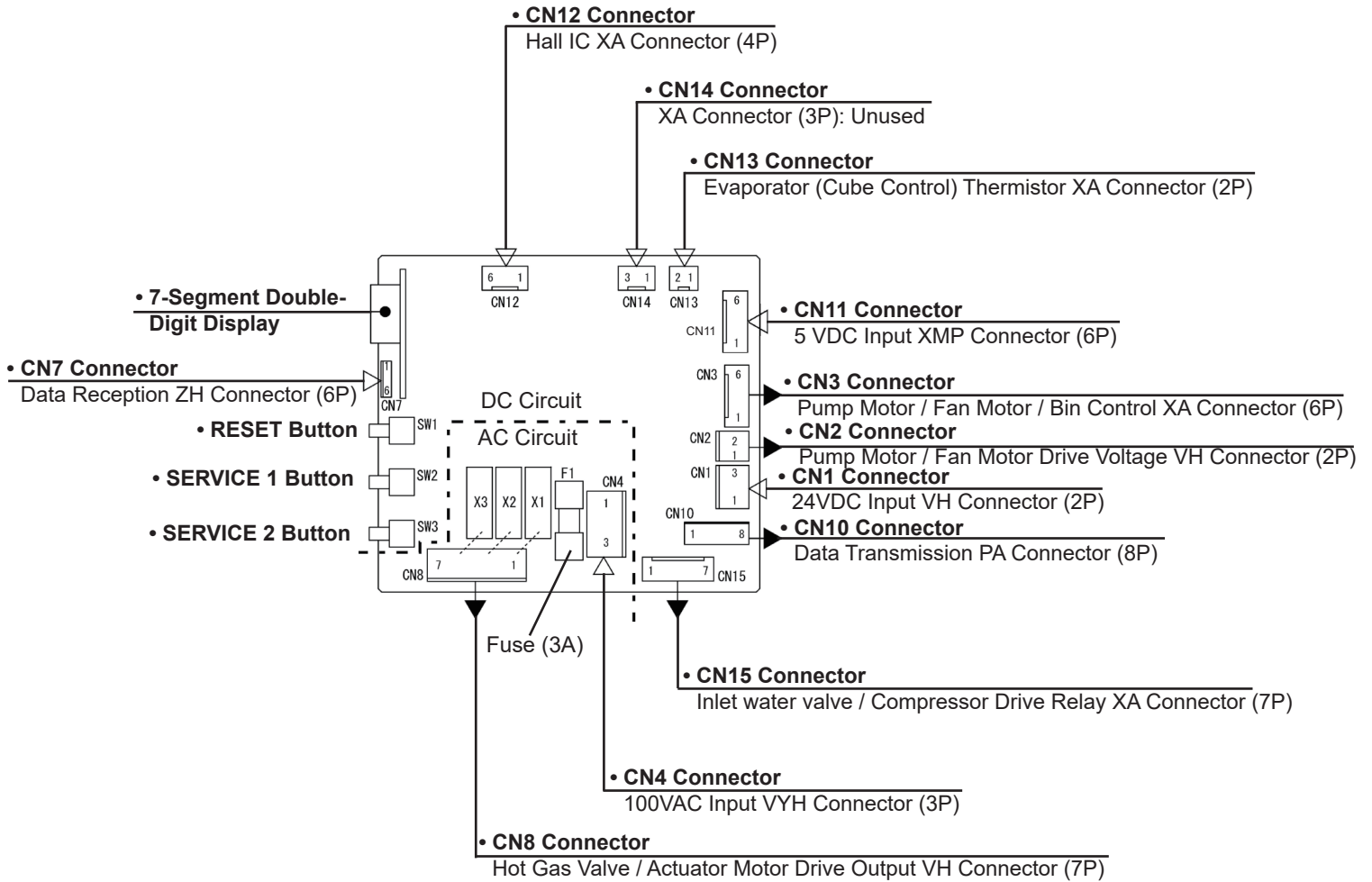

<b>"IM" Control Board</b>	
Part Number	<a href="#">P01690-02</a> Version 1.2E or Later

## C. Control Buttons

The control board features RESET, SERVICE 1, and SERVICE 2 Buttons

### 1. RESET Button

- Press briefly to go to initial harvest cycle.
- Press and hold for 3 seconds to enter control board setting mode. For details about control board settings, see "III.D. Control Board Settings."

### 2. SERVICE 1 and SERVICE 2 Buttons

- Press the "SERVICE 1" or "SERVICE 2" button to select the desired setting number.
- Press the "SERVICE 1" button to increase the number and the "SERVICE 2" button to decrease the number.
- Press the "RESET" button to flash the set value on the display.
- Press the "SERVICE 1" or "SERVICE 2" button to select the desired value.
- Press the "RESET" button to memorize the set value and return to the setting number.
- Leave the buttons untouched for 30 seconds to shift to the normal mode.

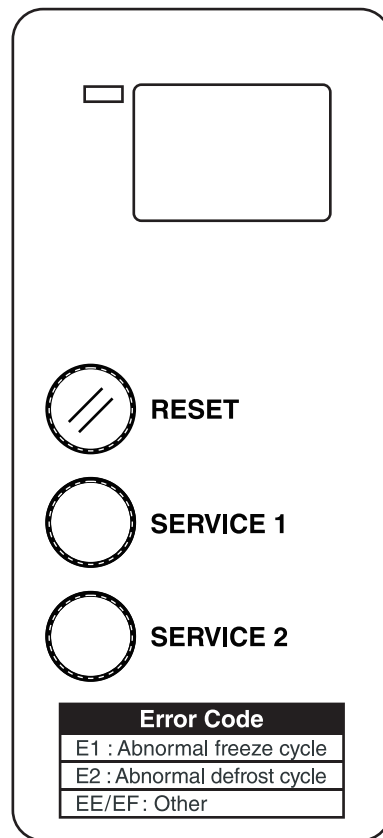

**Fig. 2**

## D. Control Board Settings

<b><i>NOTICE</i></b>
----------------------

Failure to maintain factory settings may adversely affect performance and warranty coverage. For more information, contact your Hoshizaki Service Center.
---

- 1) With "on" in display, press and hold the "RESET" button for 3 seconds. Display changes to "1".
- 2) Use the "SERVICE 1" and "SERVICE 2" buttons to choose a control board setting.
- 3) Press the "RESET" button to view the setting's value. Current value flashes in display.
- 4) Use the "SERVICE 1" and "SERVICE 2" buttons to change value.
- 5) Press the "RESET" button to select value. Display returns to control board setting number.
- 6) Once display returns to "on" (30 seconds), the new setting is saved.

<b>Control Board (CB) Setting Menu</b>				
<b>Category</b>	<b>No.</b>	<b>Item</b>	<b>Range</b>	<b>Default</b>
Basic	1	<u>Harvest Cycle Termination Temperature</u> Temperature to complete harvest cycle (detected by evaporator (cube control) thermistor).	2 to 20°C (1°C increments)	10
	2	<u>Freeze Cycle Termination Temperature</u> Target integrated value inside control board is determined by CB Settings 2 and 3. Temperature in freeze cycle is integrated, and freeze cycle continues until target integrated value is reached, which determines dimple diameter setting 2 (medium). Basically, the smaller CB Setting 2 gets, the larger integrated value and the smaller dimple diameter become.	-5 to -40°C (0.5°C increments. The "." in the lower, right corner of the display indicates .5°C.)	-20.5
	3	<u>Freeze Cycle Termination Time</u> Target integrated value inside control board is determined by CB Settings 2 and 3. Time in freeze cycle is integrated, and freeze cycle continues until target integrated value is reached, which determines dimple diameter setting 2 (medium). Basically, the smaller CB Setting 3 gets, the smaller integrated value and the larger dimple diameter become.	5 to 90 min. (1 min. increments)	38
	4	<u>Ambient Temperature Correction Value for Freeze Cycle Termination</u> Upper temperature limit to trip control to ensure minimum dimple size in low temp conditions like at 1°C / wt 5°C.	10 to 50°C (1°C increments)	25
	5	<u>Ambient Temperature Correction Rate for Freeze Cycle Termination</u> Percentage of integrated value in low temp conditions against target integrated value to ensure minimum dimple size in low temp conditions like at 1°C / wt 5°C based on integrated value inside control board determined by CB Settings 2 and 3.	10 to 100% (00=100) (1% increments)	85
	6	<u>Freeze Cycle Backup Timer</u> Timer setting to forcibly terminate freeze cycle if evaporator (cube control) thermistor cannot sense freeze cycle termination temp.	45 to 90 min. (5 min. increments)	60
	7	<u>Dimple Diameter Setting 3 (Large)</u> Determines dimple diameter for dimple diameter setting 3 by percentage against target integrated value. The smaller the setting gets, the larger the diameter becomes. The larger the setting gets, the smaller the diameter becomes. <b>SETTING CHANGE IS INEFFECTIVE.</b>	50 to 95% (1% increments)	95
	8	<u>Dimple Diameter Setting 1 (Small)</u> Determines dimple diameter for dimple diameter setting 1 by percentage against target integrated value. The smaller the setting gets, the larger the diameter becomes. The larger the setting gets, the smaller the diameter becomes. <b>SETTING CHANGE IS INEFFECTIVE.</b>	105 to 130% (05 to 30 displayed) (1% increments)	105









<b>Control Board (CB) Setting Menu</b>				
<b>Category</b>	<b>No.</b>	<b>Item</b>	<b>Range</b>	<b>Default</b>
Water Supply	10	<u>Harvest Cycle Water Supply Time: Water Temperature Lower Than 13°C</u> Time to supply harvesting water to melt ice on water plate at water supply temp lower than 13°C. Adjustable between 1 and 99 sec. When set to "99", harvesting water keeps running until evaporator (cube control) thermistor senses harvesting completion temp.	1 to 99 sec, 99=continuous (1 sec. increments)	1
	11	<u>Harvest Cycle Water Supply Time: Water Temperature 13°C or Higher</u> Time to supply harvesting water to melt ice on water plate at water supply temp of 13°C or higher. Adjustable between 1 and 99 sec. When set to "99", harvesting water keeps running until evaporator (cube control) thermistor senses harvest completion temp.	1 to 99 sec, 99=continuous (1 sec. increments)	1
	12	<u>Freeze Cycle Water Supply Time: Partial/Full Drain</u> Time to supply icemaking water depending on partial or full drain flush.	0 to 90 sec. (1 sec. increments)	0
	13	<u>Water Temperature Correction Value</u> Value added to correct the difference between the temperature at the evaporator (cube control) thermistor and actual water supply temperature.	+0 to +20K (1K increments)	4
	14	<u>Partial/Full Drain Flush Selection</u> Selection between full and partial drain flush of icemaking water plate in case of cloudy ice production even after hard water control. Ice-making water supply time and water plate overflow pipe direction need to be changed.	Partial=1; Full=0	0
	15	<u>Freeze Cycle Water Supply Time</u> Time to supply additional icemaking water required after pump motor starts following normal icemaking water supply time.	0 to 90 sec. (1 sec. increments)	15
	16	<u>Low Water Detection Time</u> Time to detect low water within which pump motor starts and reaches the target rotation speed. The longer set time becomes, the easier low water detects. The shorter set time becomes, the harder low water detects. No low water detection when set to "0". <b>SETTING CHANGE IS INEFFECTIVE.</b>	0 to 90 sec. 0=no detection (1 sec. increments)	0
Other	20	<u>Display Switching in Operation</u> Switches 7-segment display during operation. "0": Display constantly shows "on". "1": Display shows "on" for 3 min just after power supply is turned on and then shows bar such as " _ _ " based on operational status. <b>SETTING CHANGE IS INEFFECTIVE.</b>	0="on" constantly displayed 1=bar displayed	0
	21	<u>Stackable Bin Control</u> Allows for stacked units to be controlled through one bin control. <b>DO NOT ADJUST</b>	Yes=1; No=0	1

<b>Control Board (CB) Setting Menu</b>				
<b>Category</b>	<b>No.</b>	<b>Item</b>	<b>Range</b>	<b>Default</b>
Other, continued	22	<u>Refrigeration Circuit Cycling when Bin Full</u> Selection of control to prevent ice in storage bin from melting in bin control cycle (by operating refrigeration unit). <b>SETTING CHANGE IS INEFFECTIVE.</b>	On=1; Off=0	0
Fan Motor	30	<u>Type</u> Selection of fan motor type. When set to "0", unit operates as water-cooled model.	0=water-cooled 1=small / medium 2=large 4=new small	4
	31	<u>Target Rotation Speed</u> Normal fan motor rotation speed set with the first two digits for 4-digit numbers and the first digit for 3-digit numbers. e.g. 1600 r/min = "16", 800 r/min = "8"	3 to 20 (x 100 rotations) (1 increments)	14
	32	<u>Low Speed Rotation Temperature</u> Condition to decrease target fan motor rotation speed. When ambient temperature reaches down to low speed rotation temperature (CB Setting 32), target rotation speed is decreased by low speed rotation rate (CB Setting 33).	10 to 45°C (1°C increments)	25
	33	<u>Low Speed Rotation Rate</u> Percentage against target rotation speed (CB Setting 31).	20 to 100% (00=100) (1% increments)	100
	34	<u>High Speed Rotation Temperature</u> Condition to increase target fan motor rotation speed. When ambient temperature reaches up to high speed rotation temperature (CB Setting 34), target rotation speed is increased by high speed rotation rate (CB Setting 35).	50 to 60°C (1°C increments)	60
	35	<u>High Speed Rotation Rate</u> Percentage against target rotation speed (CB Setting 31).	100 to 120% (00 to 20 displayed) (1% increments)	100
Water Regulating Valve	36	<u>Water Regulating Valve Error Detection Temperature</u> Thermistor temperature (water regulating valve outlet) in case of water regulating valve error and cooling water failure for water-cooled model. <b>DO NOT ADJUST</b>	0 to 50°C 0=ignore (1°C increments)	0
Pump Motor	40	<u>Type</u> Selection of pump motor type. <b>DO NOT ADJUST</b>	1=small 2:=medium 3=large	1
	41	<u>Target Rotation Speed</u> Normal pump motor rotation speed set with the first two digits of rotation speed. e.g. 3800 r/min = "38" When freeze cycle integrated value against target is less than low speed rotation condition (CB Setting 42), pump motor operates at target rotation speed. When integrated value is low speed rotation condition (CB Setting 42) or higher, target rotation speed is decreased by low speed rotation rate (CB Setting 43).	15 to 45 (x 100 rotations) (1 increments)	32

<b>Control Board (CB) Setting Menu</b>				
<b>Category</b>	<b>No.</b>	<b>Item</b>	<b>Range</b>	<b>Default</b>
Pump Motor, continued	42	<u>Low Speed Rotation Condition</u> Condition to decrease target pump motor rotation speed in freeze cycle.	10 to 100% (00=100) (1% increments)	30
	43	<u>Low Speed Rotation Rate</u> Percentage against target rotation speed (CB Setting 41).	50 to 100% (1% increments)	100
Anti-Slush Control	50	<u>Pump De-Energized Time</u> Pump de-energized time for anti-slush control to de-energize pump after 2 min at evaporator temp of 3 to 4°C, quickly refrigerate evaporator before icemaking water supercools, and form ice core. When set to "0", there is no anti-slush control.	0 to 90 sec. 0=ignore (1 sec. increments)	50
	51	<u>Anti-Slush Control Water Supply Time</u> Time to supply water while pump is de-energized for anti-slush control. If slush ice is too much and cannot be prevented solely by pump de-energized time (CB Setting 50), water is supplied while pump is de-energized to slightly raise tank water temp.	0 to 5 sec. (1 sec. increments)	0
Hard Water Control	60	<u>Operating Condition</u> Condition to operate cloudy ice control in hard water application indicated in percentage against target integrated value. After icemaking water supply starts, ice begins to form and freeze cycle integrated value reaches a certain level. Then, additional water is supplied to dilute concentrated icemaking water in water tank.	10 to 100% (00=100) (1% increments)	10
	61	<u>Hard Water Control Water Supply Time</u> Time to supply water for hard water control.	0 to 90 sec. 0=ignore (1 sec. increments)	0
Water Plate Ice Control	70	<u>Operating Temperature</u> Upper limit of operating temperature to control ice left in water plate at the end of freeze cycle. Decrease amount of harvesting water by reducing ice left in opening water plate after freeze cycle. <b>SETTING CHANGE IS INEFFECTIVE.</b>	0 to 60°C (1°C increments)	44
	71	<u>Water Plate Ice Control Hot Gas Valve Energized Time</u> Hot gas valve energized time to control ice left in water plate. <b>SETTING CHANGE IS INEFFECTIVE.</b>	0 to 20 sec. 0=ignore (1 sec. increments)	0
	72	<u>Water Plate Ice Control Hot Gas Valve De-Energized Time</u> Hot gas valve de-energized time to control ice left in water plate. <b>SETTING CHANGE IS INEFFECTIVE.</b>	0 to 60 sec. 0=ignore (1 sec. increments)	0
Ice Bridge Control	73	<u>Ice Bridge Control Hot Gas Valve De-Energized Time</u> Time to keep hot gas valve de-energized after 20 sec in harvest cycle. Prevent ice bridge in bin by delaying ice dropping time. <b>SETTING CHANGE IS INEFFECTIVE.</b>	0 to 30 sec. 0=ignore (1 sec. increments)	0

## E. Control Board Information Display

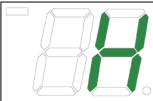
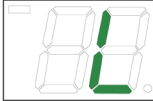
1. With unit on, press and hold the "SERVICE 1" button for 3 seconds. Display changes to "n1".
2. Use the "SERVICE 1" and "SERVICE 2" buttons to move through the list.
3. Press the "RESET" button to view the item's value.
4. Press the "RESET" button to return to list.
5. Display returns to normal if no buttons are touched for 20 seconds.

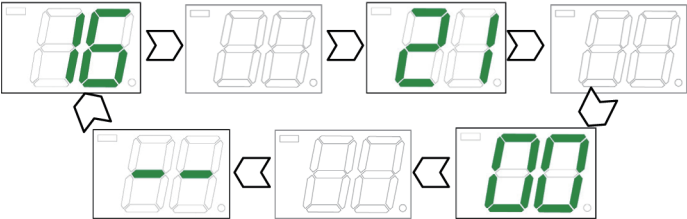
Control Board Information Display		
No.	Item	Display (example)
-	n*, h*	 
n1	Freeze cycle time count up (min)	21 min or 21% 
n2	Freeze cycle completion rate (%)	100% (last 2 digits only) 
n3	Current evaporator (cube control) thermistor temp	-2°F (-19°C) 
n4	Current control board thermistor temp	75°F (24°C) 
n5	Water temp (presumed)	Water temp 55°F (13°C) or more  Water temp less than 55°F (13°C) 
n6	Current fan motor rotation speed	If actual rotation speed is 1560 r/min The first two digits after actual rotation speed is rounded to the nearest 10. 
n7	Current pump motor rotation speed	
h1	Last freeze cycle time (min)	21 min 
h2	Number of freeze cycles	If counted number of cycles is 162100 
h3	Total number of freeze cycles	

Control Board Information Display		
No.	Item	Display (example)
h4	Error log	<p>If 4 errors from latest to oldest are E4, E8, E3, and E1</p>

## F. Control Board Model Code Setting

### 1. Control Board Replacement

#### **⚠ WARNING**

- This appliance should be diagnosed and repaired only by qualified service personnel to reduce the risk of death, electric shock, serious injury, or fire.
- Move the control switch to the "OFF" position and unplug the appliance from the electrical outlet before servicing.

- 1) Remove the front panel and move the control switch to the "OFF" position. Unplug the appliance.
- 2) Remove the control box cover.
- 3) Disconnect all the connectors from the control board.
- 4) Remove the old control board and install the new control board.
- 5) Connect the connectors to the new control board.
- 6) Replace the control box cover in its correct position.
- 7) Plug in the appliance and then move the control switch to the "ICE" position.
- 8) Replace the front panel in its correct position.

## G. Error Codes

### 1. Error Codes

When the control board detects an error, the display shows one of the following error codes in the display mode. Error codes other than E1 and E2 are displayed as "EE" at the time of occurrence. To see the actual error code, see the error log.

- 1) With the unit on, press and hold the "SERVICE 1" button for 3 seconds. Display changes to "n1".
- 2) Use the "SERVICE 1" and "SERVICE 2" buttons to move through the list until "h4" is displayed.
- 3) Press the "RESET" button to view the error log. Displays up to 5 errors with the most recent error first.

- 4) Press the "RESET" button to return to list. To clear error log history, press and hold the "SERVICE 1" and "SERVICE 2" buttons simultaneously for 5 sec.
- 5) Display returns to normal if no buttons are touched for 20 sec.

<b>Error Codes</b>				
<b>Error</b>	<b>Item</b>	<b>Description</b>	<b>Operation</b>	<b>Reset</b>
E1	Freeze error	Freeze backup timer (45 minutes after water tank assembly starts to close) counts up before freeze cycle completes, and evaporator temperature is 32°F (0°C) or higher.	Shut down	Press "RESET" button
E2	Harvest error	Harvest backup timer (30 minutes after water tank starts to open) counts up before harvest cycle completes.	Shut down	Press "RESET" button
EE (E3)	Water tank assembly opening error	Water tank assembly has not fully opened within 60 seconds, and 3 minutes have passed even with opening failure control.	Halt	Press "RESET" button
		Unit resumes operation after 60 minutes and repeats the above error.	Shut down	
EE (E4)	Water tank assembly closing error	Water tank assembly has not fully closed within 50 seconds, opened and started to close again, but failed to close fully within 50 seconds.	Halt	Press "RESET" button
		Unit resumes operation after 60 minutes and repeats the above error.	Shut down	
EE (E5)	High temperature error	Evaporator temperature stays 140°F (60°C) or higher for 5 seconds or more.	Shut down	Press "RESET" button
EE (E7)	Fan motor lock	Fan motor is locked for 30 seconds with control voltage applied.	Shut down	Press "RESET" button
EE (E8)	Pump motor lock	Pump motor is locked for 30 seconds with control voltage applied.	Continue	Press "RESET" button
		Unit detects the above error 3 times.	Shut down	
EE (EA)	Data error	Model setting data memory IC is defective.	Shut down	Replace control board
EE (EC)	Evaporator (cube control) thermistor error	Evaporator (cube control) thermistor circuit is open or shorted for 2 seconds.	Shut down	Replace thermistor

## 2. Service Diagnosis

<b>Error Codes</b>			
<b>Error</b>	<b>Check</b>	<b>Possible Cause</b>	<b>Remedy</b>
E1	Inlet water valve	Closing failure	Clean or replace
	Refrigeration circuit	Gas leak	Repair
		Clogged capillary	Replace heat exchanger
		Clogged expansion valve	Replace
	Compressor	Defective	Replace
		Starting failure	Check supply voltage or replace electrical components
	Compressor relay	Coil circuit open	Replace
	Condenser	Clogged	Clean
	Fan motor	Locked	Replace
		Low RPM	Replace
		Broken fan	Replace fan
	Hot gas valve	Closing failure	Replace
	Control board	Blown fuse	Replace fuse
Evaporator (cube control) thermistor	Disconnected	Reconnect	
E2	Hot gas valve	Opening failure	Replace
	Control board	Blown fuse	Replace fuse
EE (E3)	Actuator motor	Defective	Replace
	Control board	Relay contact failure	Replace
		Blown fuse	Replace fuse
EE (E4)	Actuator motor	Defective	Replace
	Control board	Relay contact failure	Replace
		Blown fuse	Replace fuse
EE (E5)	Hot gas valve	Closing failure	Replace
	Control board	Relay contact failure	Replace
EE (E7)	Fan motor	Locked	Replace
		Locked fan	Remove obstacle
		Connector disconnected	Reconnect
		Open circuit	Repair
EE (E8)	Pump motor	Locked	Replace
		Connector disconnected	Reconnect
		Open circuit	Repair
EE (EA)	Control board	Data error	Replace
EE (EC)	Evaporator (cube control) thermistor	Open or short circuit	Replace
	Control board	Connector disconnected	Reconnect

## IV. Refrigeration Circuit and Component Service Information

### **⚠ WARNING**

- This appliance should be diagnosed and repaired only by qualified service personnel to reduce the risk of death, electric shock, serious injury, or fire.
- To reduce the risk of electric shock, do not touch the control switch or plug with damp hands. Make sure the control switch is in the "OFF" position before plugging in or unplugging the appliance.
- Move the control switch to the "OFF" position and unplug the appliance from the electrical outlet before servicing.
- **CHOKING HAZARD:** Ensure all components, fasteners, and thumbscrews are securely in place after any maintenance is done to the appliance. Make sure that none have fallen into the storage bin.
- Make sure all food zones in the icemaker and storage bin are clean after service.

### A. Refrigeration Circuit Service Information

#### **⚠ WARNING**

- Repairs requiring the refrigeration circuit to be opened must be performed by properly trained and EPA-certified service personnel.
- Use an electronic leak detector or soap bubbles to check for leaks. Add a trace of refrigerant to the system (if using an electronic leak detector), and then raise the pressure using nitrogen gas (140 PSIG). Do not use R-134a as a mixture with pressurized air for leak testing.

#### **NOTICE**

- Always recover the refrigerant and store it in an approved container. Do not discharge the refrigerant into the atmosphere.
- Do not leave the system open for longer than 15 min. when replacing or servicing parts. The Polyol Ester (POE) oils used in R-134a applications can absorb moisture quickly. Therefore it is important to prevent moisture from entering the system when replacing or servicing parts.
- Always install a new drier every time the sealed refrigeration system is opened. Do not replace the drier until after all other repair or replacement has been made. Install the new drier with the arrow on the drier in the direction of the refrigerant flow.
- When brazing, protect the drier by using a wet cloth to prevent the drier from overheating. Do not allow the drier to exceed 250°F (121°C).

#### 1. Refrigerant Recovery

No refrigerant access valves are provided on this appliance. Using proper refrigerant practices, utilize a temporary tap-line valve on the high side to recover the refrigerant. Store the refrigerant in an approved container. Do not discharge the refrigerant into the atmosphere. After recovery is complete, replace the tap-line valve with a proper, permanent access valve.

## 2. Brazing

### **⚠ WARNING**

- R-134a itself is not flammable at atmospheric pressure and temperatures up to 176°F (80°C).
- R-134a itself is not explosive or poisonous. However, when exposed to high temperatures (open flames), R-404A can be decomposed to form hydrofluoric acid and carbonyl fluoride both of which are hazardous.
- Do not use silver alloy or copper alloy containing arsenic.

1) Braze all fittings while purging with nitrogen gas flowing at a pressure of 3 to 4 PSIG.

Note: Because the pipes in the evaporator case are specially coated to resist corrosion, it is important to make connections outside the evaporator case when possible. If it is necessary to braze inside the evaporator case, use sandpaper to remove the coating from the brazing connections before unbrazing the components.

### **NOTICE**

- Always install a new drier every time the sealed refrigeration system is opened.
- Do not replace the drier until after all other repair or replacement has been made. Install the new drier with the arrow on the drier in the direction of the refrigerant flow.
- When brazing, protect the drier by using a wet cloth to prevent the drier from overheating. Do not allow the drier to exceed 250°F (121°C).

2) Use an electronic leak detector or soap bubbles to check for leaks. Add a trace of refrigerant to the system (if using an electronic leak detector), and then raise the pressure using nitrogen gas (140 PSIG). Do not use R-134a as a mixture with pressurized air for leak testing.

## 3. Evacuation and Recharge (R-134a)

1) Attach a vacuum pump to the system. Be sure the high-side charging hose is connected to the field-installed high-side access valve.

### **IMPORTANT**

The vacuum level and vacuum pump may be the same as those for current refrigerants. However, the rubber hose and gauge manifold to be used for evacuation and refrigerant charge should be exclusively for POE oils.

- 2) Turn on the vacuum pump. Open the gauge manifold valves. Never allow the oil in the vacuum pump to flow backwards.
- 3) Allow the vacuum pump to pull down to a 29.9" Hg vacuum. Evacuating period depends on pump capacity.
- 4) Close the high-side valve on the gauge manifold.
- 5) Disconnect the gauge manifold hose from the vacuum pump and attach it to a refrigerant service cylinder. Remember to loosen the connection and purge the air

from the hose. For the required refrigerant charge, see the nameplate. Hoshizaki recommends only virgin refrigerant or reclaimed refrigerant which meets AHRI Standard 700 (latest edition) be used.

- 6) A liquid charge is required when charging an R-134a system. Place the service cylinder on the scales; if the service cylinder is not equipped with a dip tube, invert the service cylinder, then place it on the scales. Open the high-side valve on the gauge manifold.
- 7) Allow the system to charge with liquid until the proper charge weight is met.
- 8) Close the high-side valve on the gauge manifold, then close the refrigerant access valve (if applicable). Disconnect the gauge manifold hose.
- 9) Cap the access valve to prevent a possible leak.

## B. Component Service Information

### 1. Cabinet

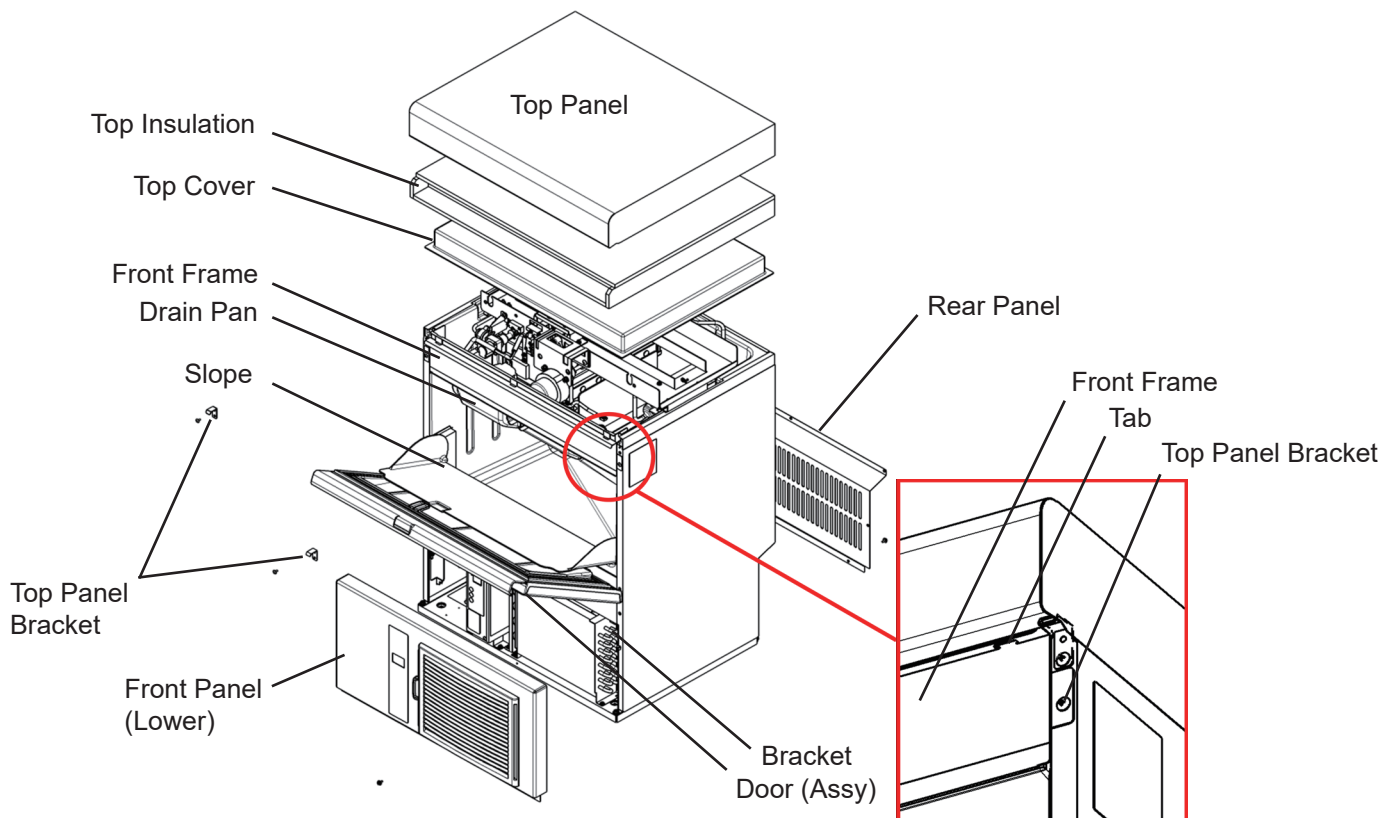

#### [a] Top Panel, Top Insulation, Top Cover

- 1) Remove the top panel bracket (at both sides of the front) hooking the front of the top panel.
- 2) Lift up the front of the top panel, slide it to the rear by 2/5" (10 mm), and lift it off. The top insulation and top cover (fitted in the top panel) come off together with the top panel.
- 3) Replace the removed parts in the reverse order of the removal procedure.

### [b] Front Frame, Drain Pan

- 1) Remove the front frame, and release its tab from the drain pan.
- 2) Pull off the drain pan towards you. (The rear of the drain pan rests on the projection from the bin.)
- 3) Replace the removed parts in the reverse order of the removal procedure.

### [c] Front Panel (Lower)

- 1) Unscrew the front panel (lower), lift it up by 2/5" (10 mm), and pull it off towards you. (The front panel (lower) is hooked on the bracket screws.)
- 2) Replace the removed parts in the reverse order of the removal procedure.

### [d] Rear Panel

- 1) Unscrew and remove the rear panel.
- 2) Replace the removed parts in the reverse order of the removal procedure.

### [e] Door Assembly, Slope, Spring

- 1) Unhook the bottom of the spring from the sheet metal hook, and then the top of the spring from the spring hook.
- 2) Lift the center of the slope off the shafts at both sides of the bin. (The shafts are fit in the concaves at both sides of the slope.)
- 3) With the door open, remove the bolts fixing the hinges. (Insert a screwdriver from inside the bin to the hinge bolts.)
- 4) Pull off the door assembly towards you to remove it from the hinges. (Then remove the hinges from the body.)
- 5) Pull off the door stopper and door hook fitted to the door assembly from the slotted hole in the front of the body. (The door stopper can be removed from the door assembly before it is pulled off.)
- 6) Replace the removed parts in the reverse order of the removal procedure.

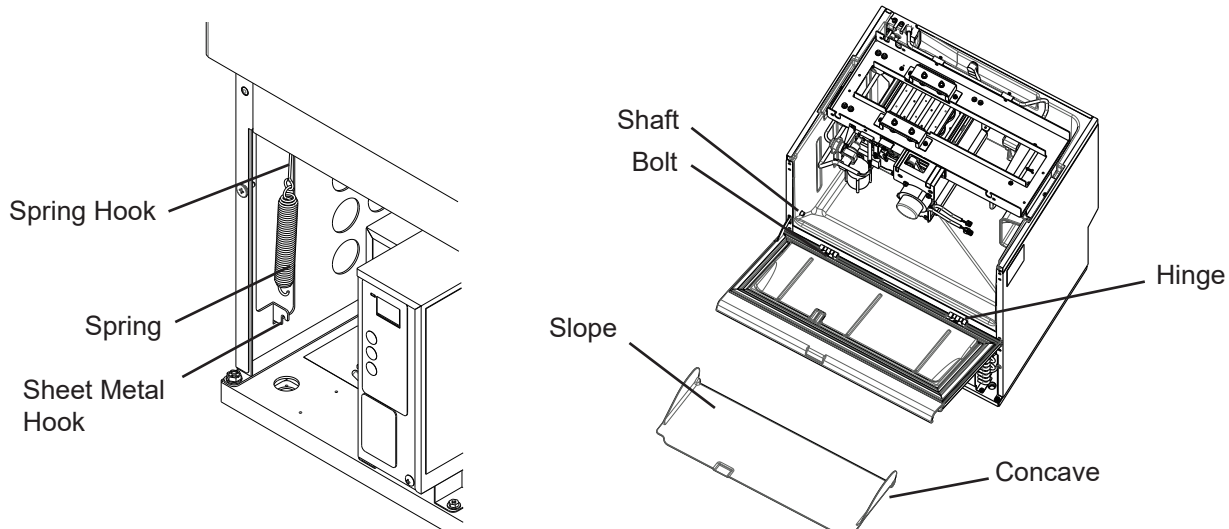

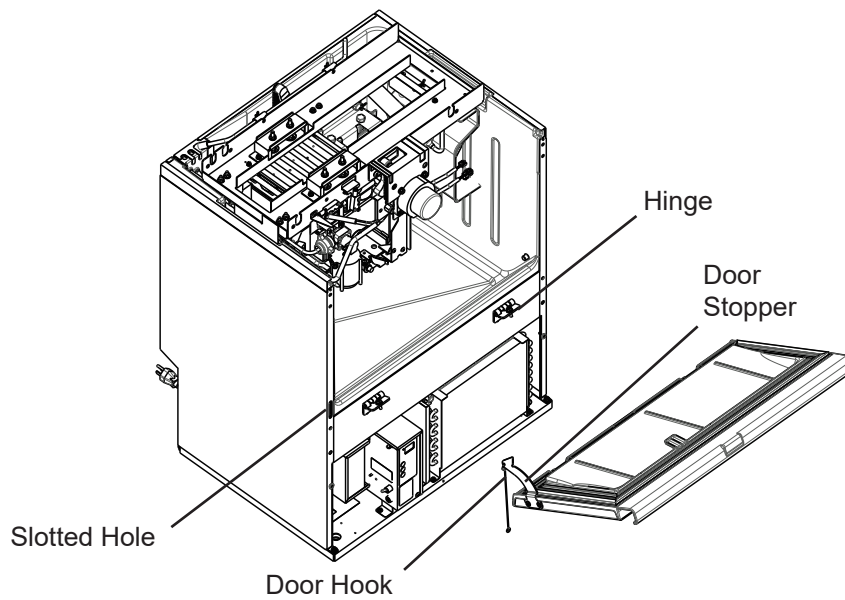

## 2. Refrigeration Circuit

\* See "A. Refrigeration Circuit Service Information" for refrigerant recovery/charge and copper tube brazing instructions.

### [a] Compressor

- 1) Remove the front panel (lower) and rear panel, move the control switch to the "OFF" position, and then unplug the appliance.
- 2) Remove the control box and air guide from the machine compartment.
- 3) Remove the access valve from the condenser shroud to recover the refrigerant from the valve.
- 4) Remove the compressor terminal cover and then remove the start relay and start capacitor.
- 5) Remove the ground wire from the compressor ground terminal.
- 6) Remove the compressor fixing snap pins.
- 7) Remove the discharge, suction and access pipes from the compressor using brazing equipment.
- 8) Pull out the compressor from the rear side.
- 9) Replace the compressor, and braze the access, suction and discharge pipes.
- 10) Replace the removed parts in the reverse order of the removal procedure.

## [b] Condenser

- 1) Remove the front panel (lower), move the control switch to the "OFF" position, and then unplug the appliance.
- 2) Remove the control box and air guide from the machine compartment.
- 3) Remove the access valve from the condenser shroud to recover the refrigerant from the valve.
- 4) Unscrew the condenser, and pull out the condenser.
- 5) The shroud, fan motor and drier come off together with the condenser.
- 6) Remove the screws fixing the shroud to the condenser from the machine compartment side. (The fan motor is fixed to the shroud.)
- 7) Remove the copper tubes from the condenser using brazing equipment.
- 8) Pull out the condenser from the front side.
- 9) Replace the condenser, and braze the copper tubes.
- 10) Replace the removed parts in the reverse order of the removal procedure.

Note: When replacing the condenser in its correct position, be sure to insert the bottom of the shroud into the base hook.

## [c] Hot Gas Valve

- 1) Remove the front panel (lower) and rear panel, move the control switch to the "OFF" position, and then unplug the appliance.
- 2) Remove the control box and air guide from the machine compartment.
- 3) Remove the hot gas valve coil from the hot gas valve body.
- 4) Remove the access valve from the condenser shroud, and recover the refrigerant from the access valve.
- 5) Remove the copper tube from the hot gas valve body using brazing equipment.
- 6) Replace hot gas valve, and braze the copper tubes.
- 7) Replace the removed parts in the reverse order of the removal procedure.

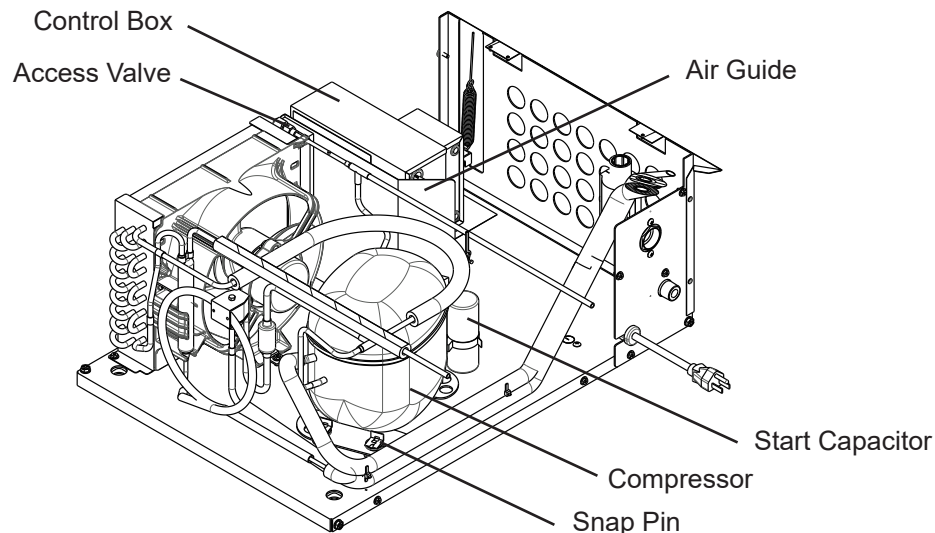

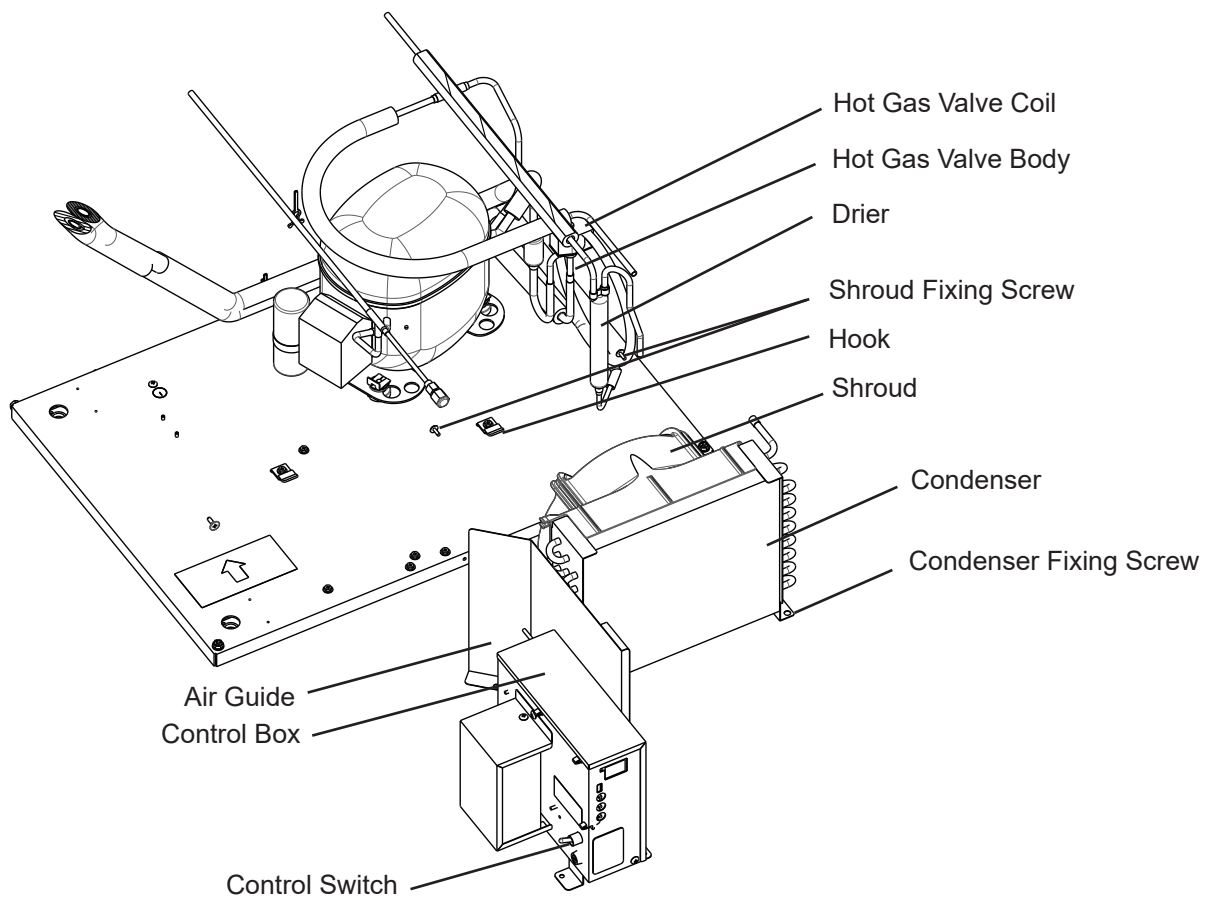

#### [d] Upper Evaporator

- 1) Remove the front panel (lower) and rear panel, move the control switch to the “OFF” position, and then unplug the appliance.
- 2) Close the water supply line shut-off valve.
- 3) Remove the top panel, top insulation, and top cover.
- 4) Remove the front frame, drain pan, ice guide, water tank assembly, inlet water valve, water supply pipe, actuator motor assembly, and cam shaft assembly.
- 5) Loosen the flange nut fixed to the evaporator bracket, and lower the evaporator to keep a distance from the mechanism base.
- 6) Remove the access valve from the condenser shroud, and recover the refrigerant from the access valve.
- 7) Remove the upper evaporator copper tubes using brazing equipment.
- 8) Remove the flange nuts fixed to the evaporator bracket to release the evaporator from the bottom side.
- 9) Remove the collars, evaporator bolts, and flange nuts from the upper evaporator.
- 10) Replace the upper evaporator, and braze the copper tubes.
- 11) Replace the removed parts in the reverse order of the removal procedure.
- 12) Open the water supply line shut-off valve.

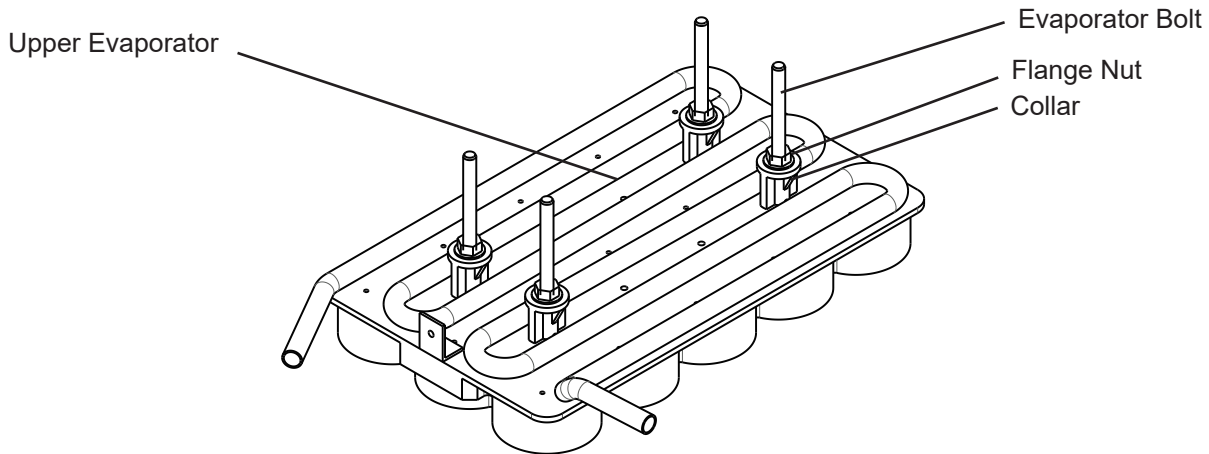
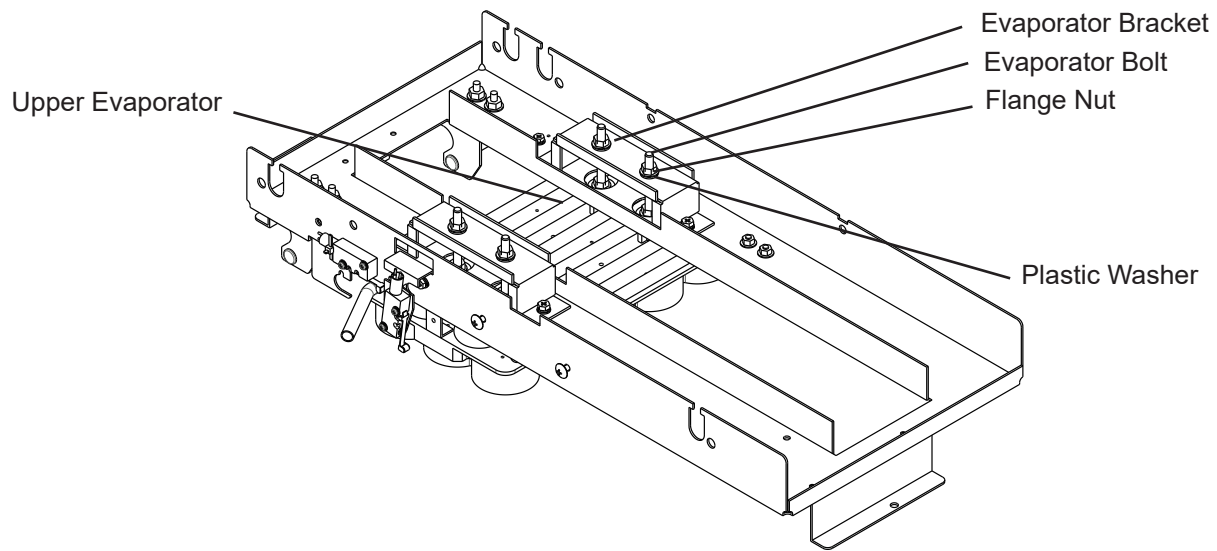
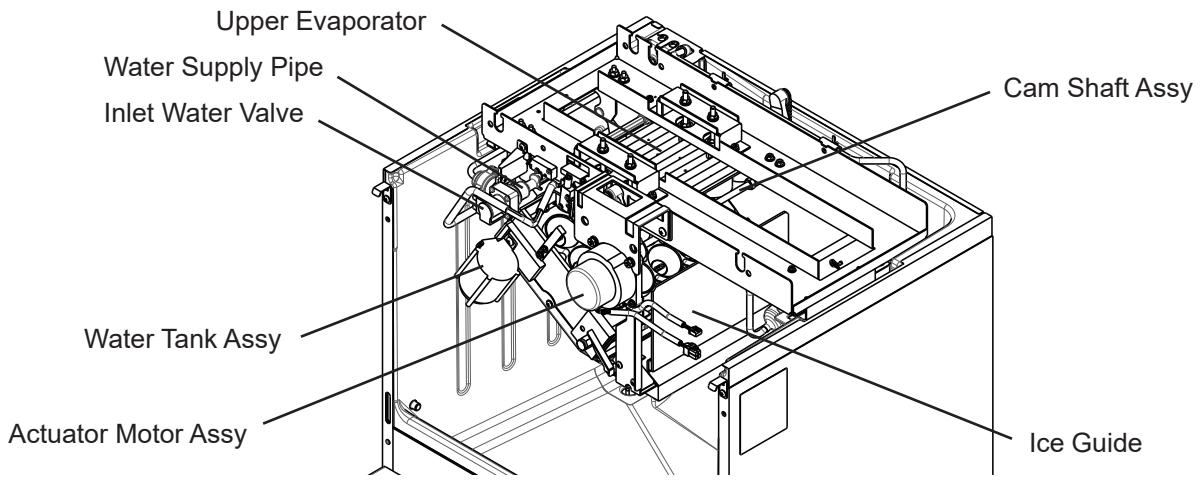

**Upper Evaporator Location Adjustment**

- 1) Loose the bolt fixing the evaporator bracket to the mechanism base to move the bracket freely.
- 2) Screw the flange nut (with the flange side up) into the evaporator bolt of the upper evaporator as far as necessary.

- 3) Insert the evaporator bolt from the bottom into the evaporator bracket hole, and put the plastic washer from the top. Then, screw the flange nut into the evaporator bolt while allowing the upper evaporator to move up and down.
- 4) Move the control switch to the "ICE" position, and press the "RESET" button. Then, the water tank assembly starts to close.
- 5) When the water tank assembly stops in its fully closed position, move the control switch to the "OFF" position.
- 6) Screw in the flange nut on the evaporator bracket so that the lower and upper evaporators fixed to the water tank assembly will have a vertical gap of 1/50" - 1/25" (0.5 - 1 mm). (When the flange nut is screwed in, the evaporator bolt moves up to raise the upper evaporator.)
- 7) When the upper evaporator is vertically positioned, screw in the flange nut under the evaporator bracket. (Use the flange nut to fix the evaporator bolt to the evaporator bracket.)
- 8) With the upper evaporator fixed to the evaporator bracket, move the evaporator bracket to fit the upper and lower evaporators from front to back and left to right. (When the exterior surfaces of the upper and lower evaporators fit perfectly, the hemispheres inside fit and make spherical ice balls.)
- 9) After the upper evaporator is positioned from front to back and left to right, fix the evaporator bracket to the mechanism base.

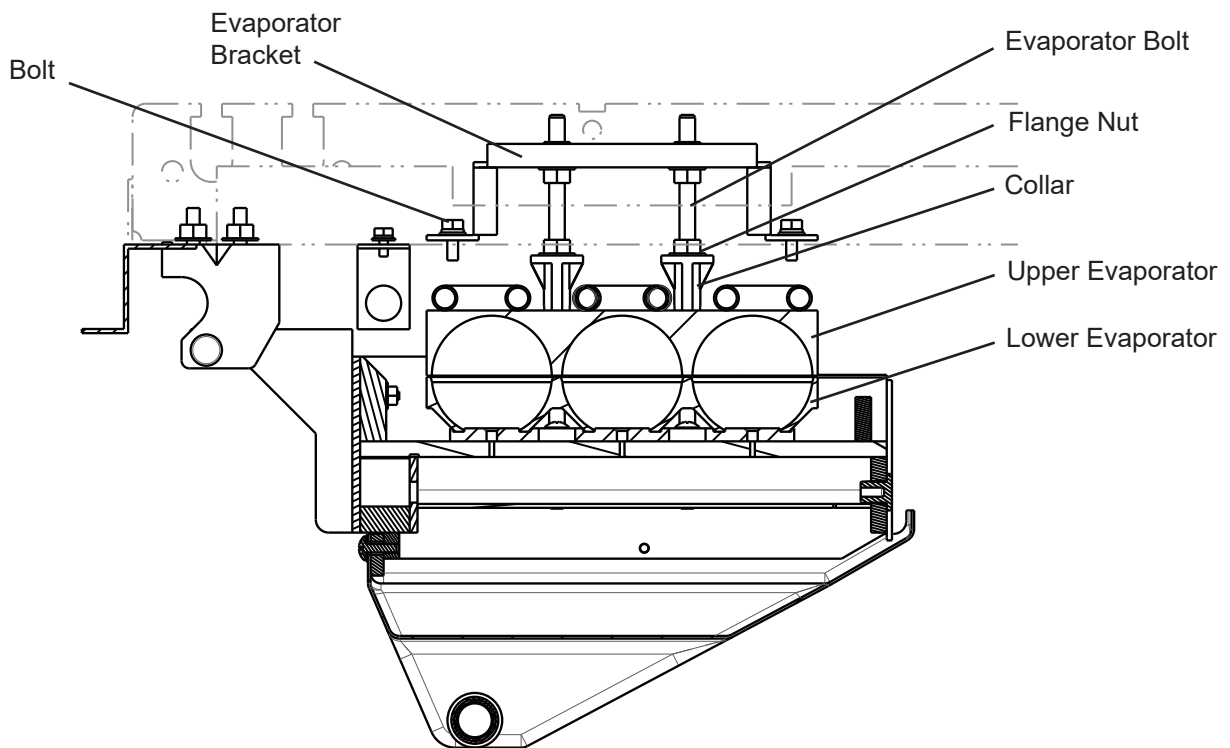

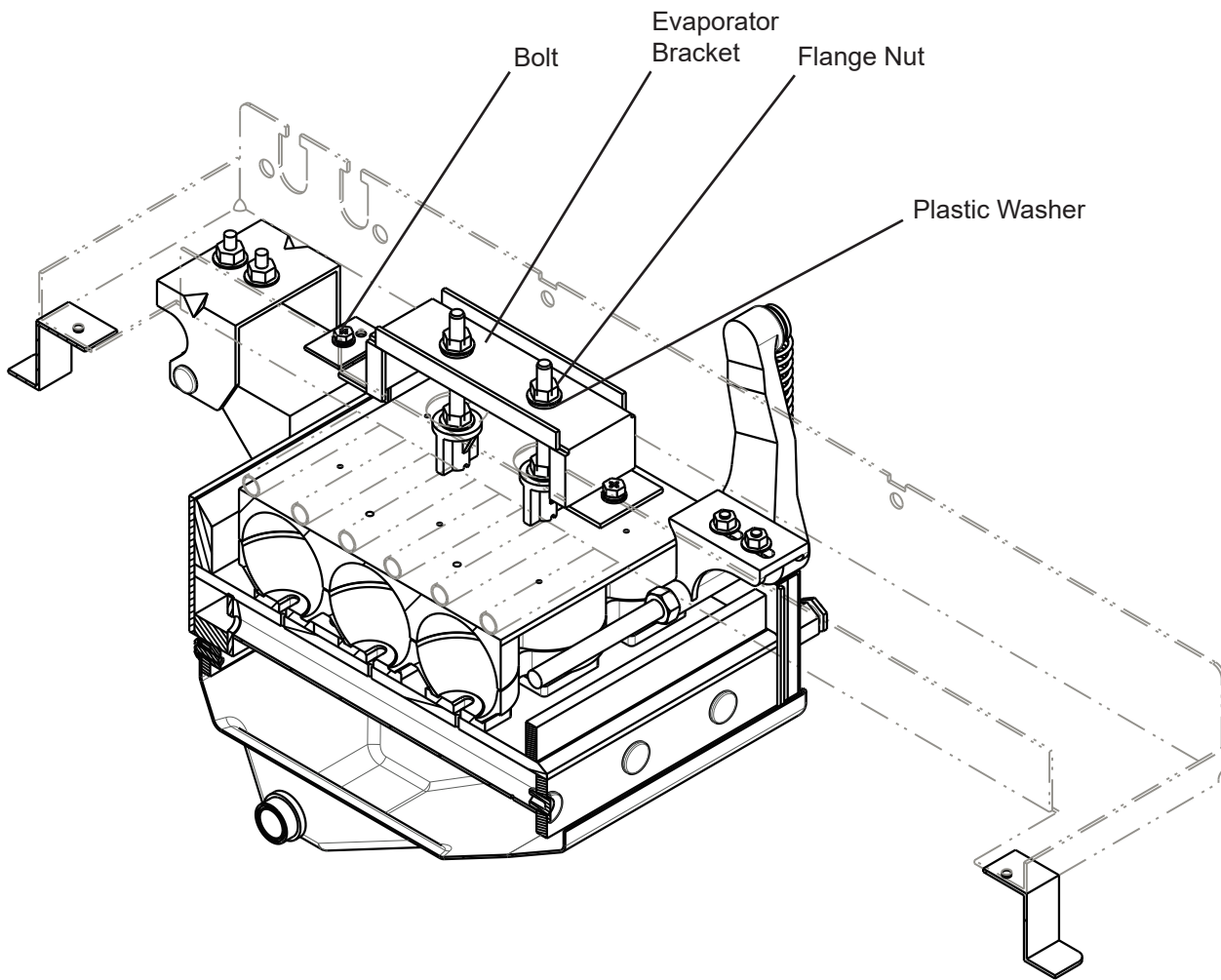

### [e] Fan Motor

- 1) Remove the front panel (lower), move the control switch to the “OFF” position, and then unplug the appliance.
  - 2) Remove the control box and air guide from the machine compartment.
  - 3) Remove the access valve from the condenser shroud.
  - 4) Unscrew and pull out the condenser. (The shroud, fan motor and drier come off together with the condenser.)
  - 5) Remove the screws fixing the shroud to the condenser from the machine compartment side. (The fan motor is fixed to the shroud.)
  - 6) Remove the nut, spring washer and washer to release the fan from the fan motor.
  - 7) Remove the bolts to release the fan motor from the shroud. (The fan motor fixing nuts are fit in the shroud.)
  - 8) Replace the fan motor and fan.
  - 9) Replace the removed parts in the reverse order of the removal procedure.
- Note: When replacing the condenser in its correct position, be sure to insert the bottom of the shroud into the base hook.

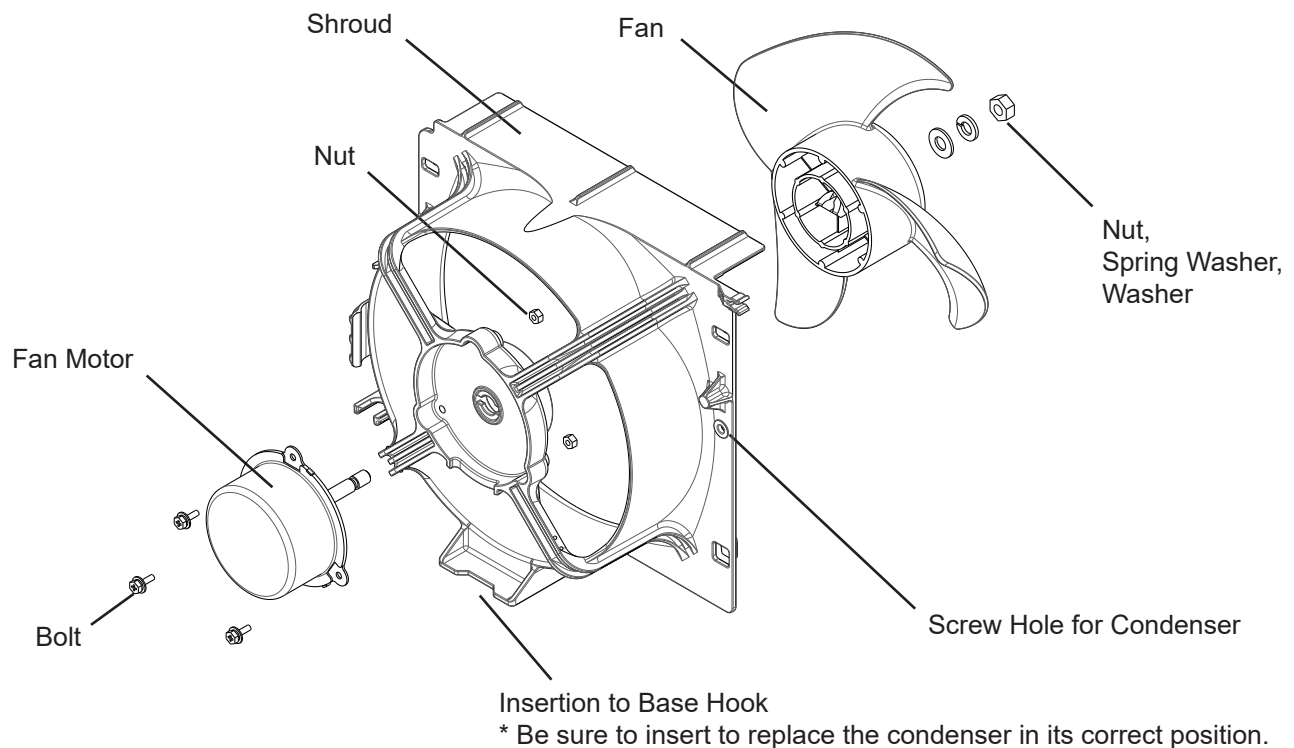

### 3. Icemaking Mechanism

- 1) Remove the front panel (lower).
- 2) Move the control switch to the "ICE" position, and press the "RESET" button. Then, the water tank assembly starts to open.
- 3) While the water tank assembly stops to open and starts to close, move the control switch to the "OFF" position, and unplug the appliance.
- 4) Remove the top panel, top insulation, top cover, front frame and drain pan.
- 5) Replace the removed parts in the reverse order of the removal procedure.

#### [a] Actuator Motor Assembly

- 1) Remove the spring from the cam (A) in the actuator motor assembly.
- 2) Remove the bolts and nuts fixing the actuator motor assembly bracket to the mechanism base.
- 3) Pull off the actuator motor assembly to disconnect the cam (A) from the cam shaft. (The plastic spacer comes off together with the actuator motor assembly.)

#### [b] Cam Shaft Assembly

- 1) Remove the spring from the cam shaft assembly.
- 2) Remove the bolts and nuts fixing the bearing in the cam shaft assembly to the mechanism base.
- 3) Pull out the cam shaft assembly from the bottom.

**[c] Water Plate Switch**

- 1) Remove the screws and nuts fixing the water plate switch to the mechanism base.

**[d] Cam Switch**

- 1) Unscrew and remove the cam switch from the switch bracket.

**[e] Water Tank Assembly**

- 1) Remove the flange nuts fixing the bearing plate to the mechanism base.
- 2) Pull out the water tank assembly with the bearing plate from the bottom.
- 3) Remove the bearing plate and spring from the water tank assembly.

**[f] Lower Evaporator**

- 1) Remove the flange nuts, spring washers, washers, evaporator screws and plastic washers under the water plate to release the lower evaporator from the water plate.

**[g] Evaporator Base**

- 1) Remove the screws fixing the evaporator base on the water plate.

**[h] Pump Motor**

- 1) Remove the screws fixing the pump motor to the side of the water plate.
- 2) Remove the discharge and suction hoses.

**[i] Water Tank**

- 1) Remove screws fixing the water tank to the water plate.

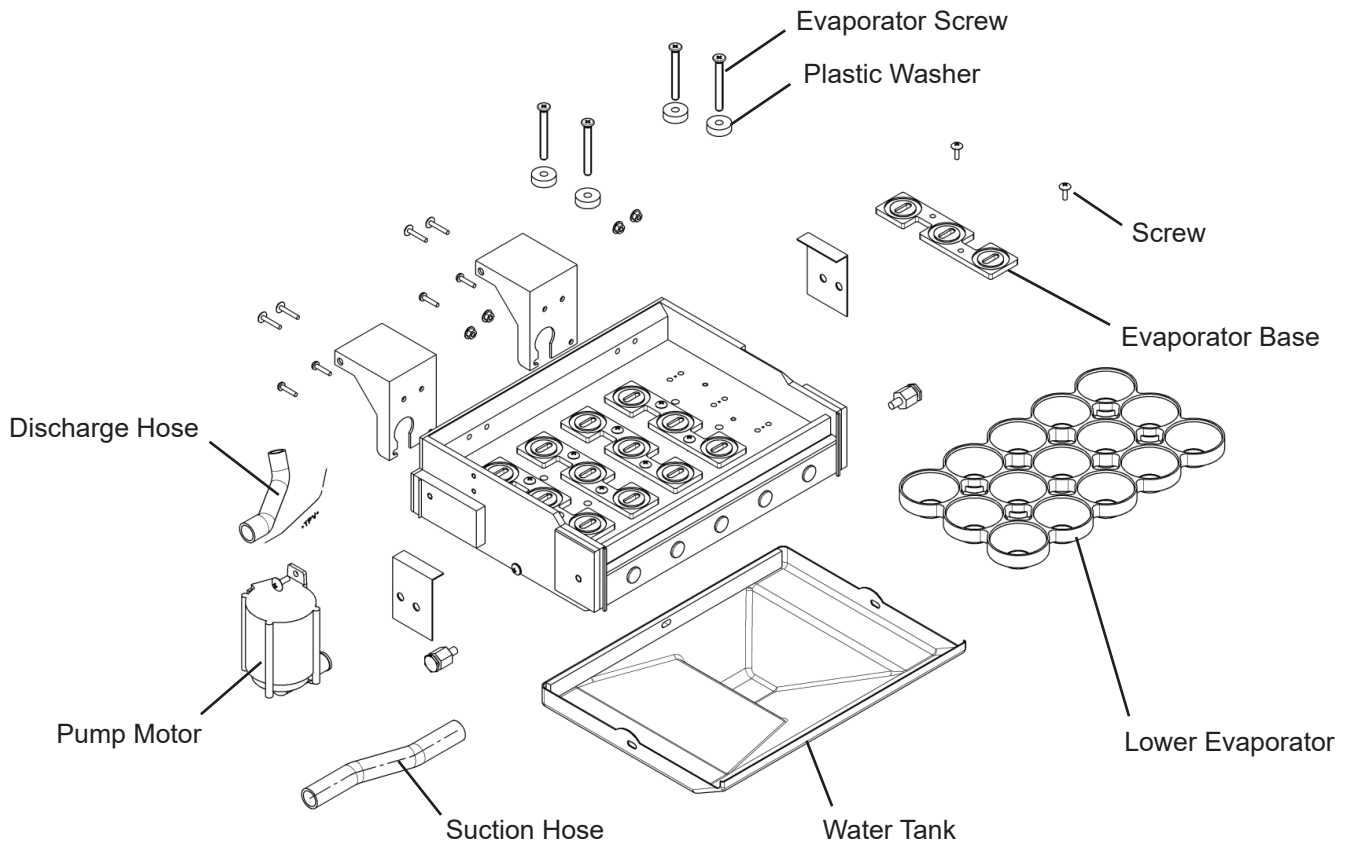
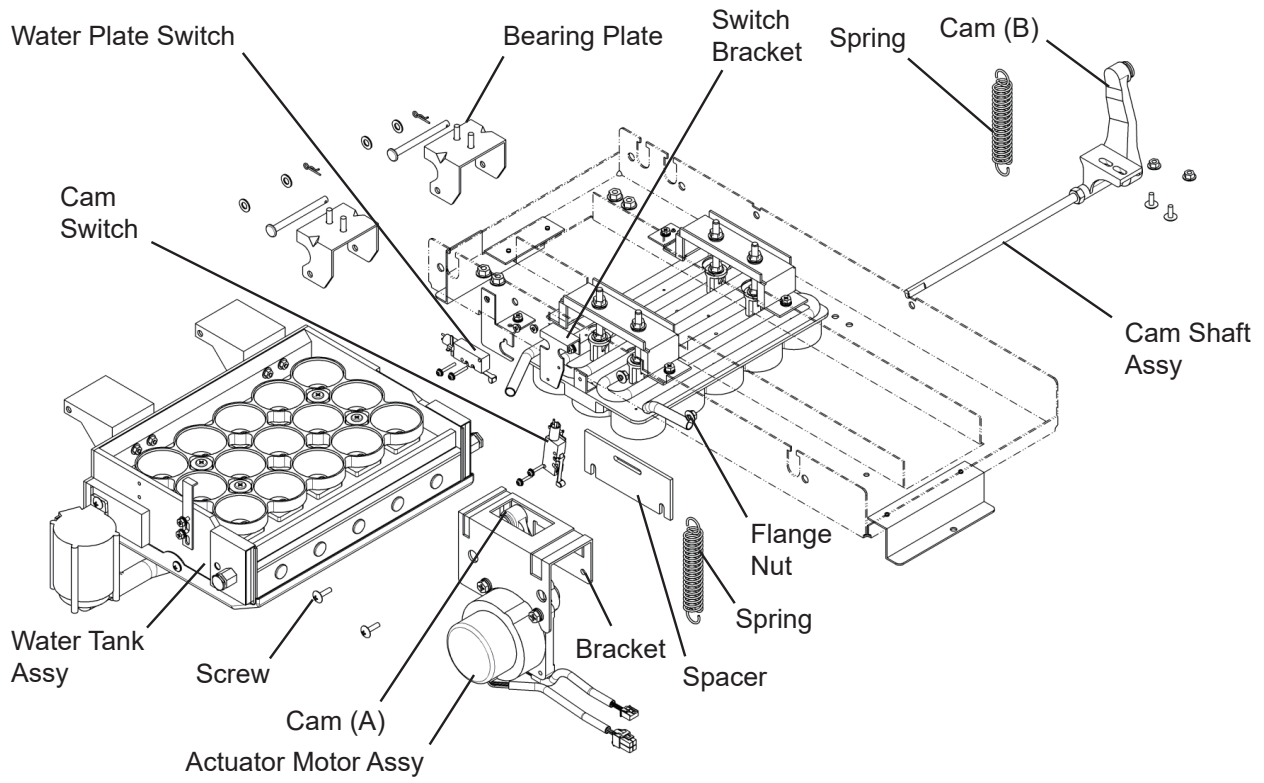

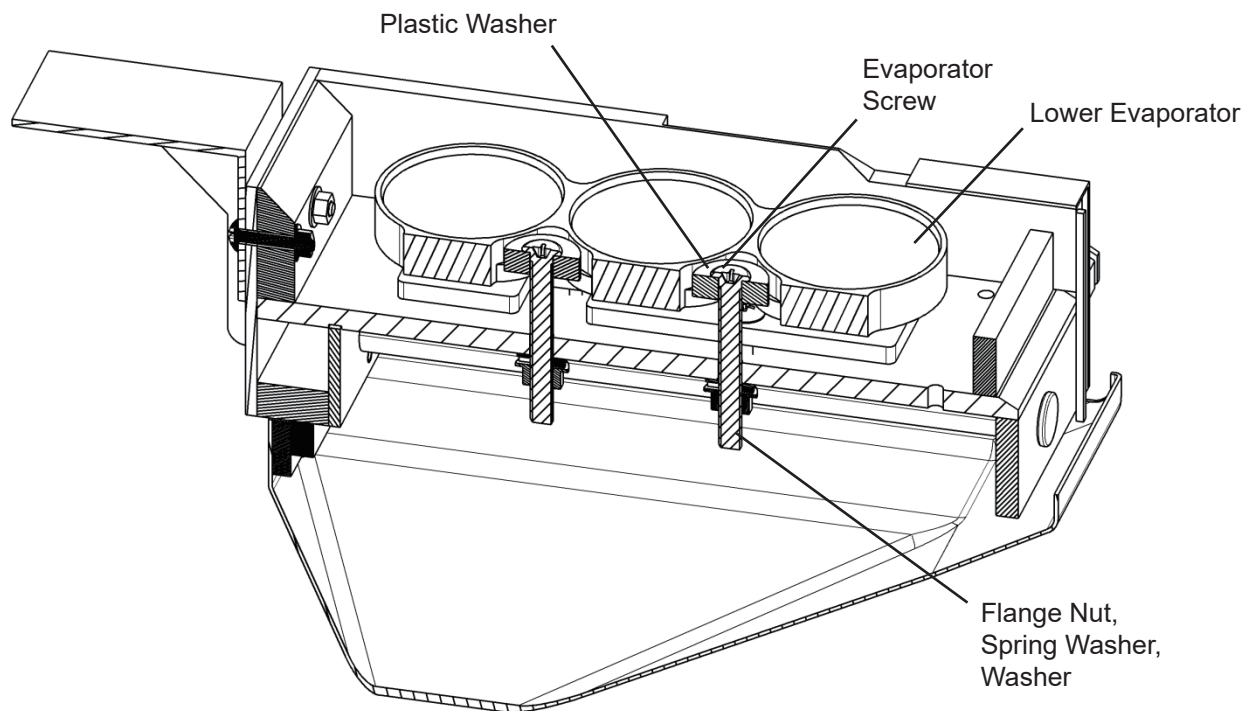

### **Water Plate Switch and Cam Switch Operation**

- 1) When harvest cycle starts after freeze cycle, the actuator motor rotates the cam counterclockwise. But the water tank assembly stays fully closed because ice is frozen to the lower evaporator.
  - 2) The cam keeps rotating until the cam switch closes (at the angle of 85° where the cam side touches the water plate), then stops.
  - 3) Then, tap water is supplied to the water plate surface, reaches 7/10" (17 mm) in height, and overflows to immerse the lower evaporator.
  - 4) Water warms the lower evaporator and raises its temperature up to around 32°F (0°C). Then, the lower evaporator separates from ice, the water tank assembly opens by its own weight, and the water plate switch opens.
  - 5) When the water plate switch does not open within a specific time, the control board operates the actuator motor, and the cam forcibly separates the lower evaporator from ice, which opens the water tank assembly and water plate switch.
  - 6) When the water plate switch opens, the actuator motor operates to open the water tank assembly and stop it at a specific angle.
  - 7) Hot gas flows into the upper evaporator to melt the surface of ice stuck there.
- \* The compressor stops after freeze cycle until the cam switch opens.

### **Water Plate Switch Positioning**

- 1) To adjust the water plate switch position, loosen the bolts fixing the lever to the side of the water tank assembly, and move the lever up or down.
- 2) Check that the water plate switch closes when the water tank assembly is fully closed.

## **Cam Switch Positioning**

- 1) To adjust the cam switch position, loosen the bolts fixing the switch bracket, and move it to the left-or-right.
- 2) Check that the cam switch closes when the cam is in the location shown below.

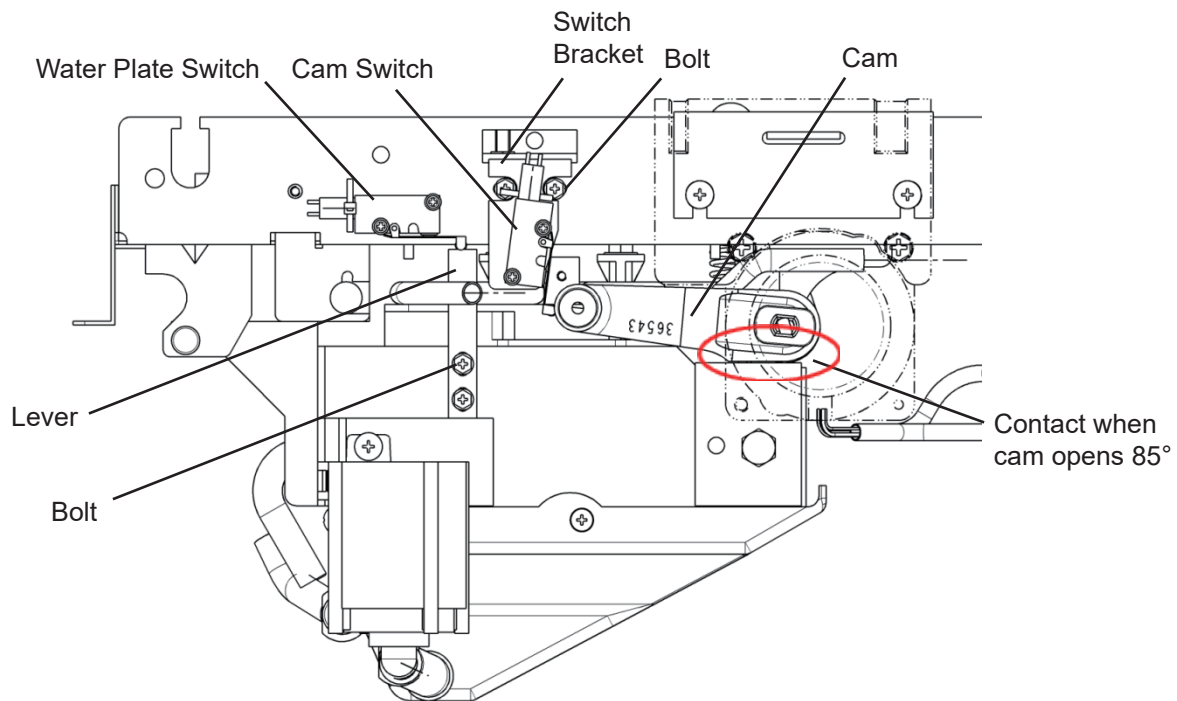

## **[j] Ice Guide**

- 1) Remove the bolts fixing the ice guide assembly to the actuator motor and the rear of the bin.
- 2) Remove the screws fixing the ice guide shaft.
- 3) Remove the plate from the ice guide.
- 4) Replace the ice guide.
- 5) Replace the removed parts in the reverse order of the removal procedure.

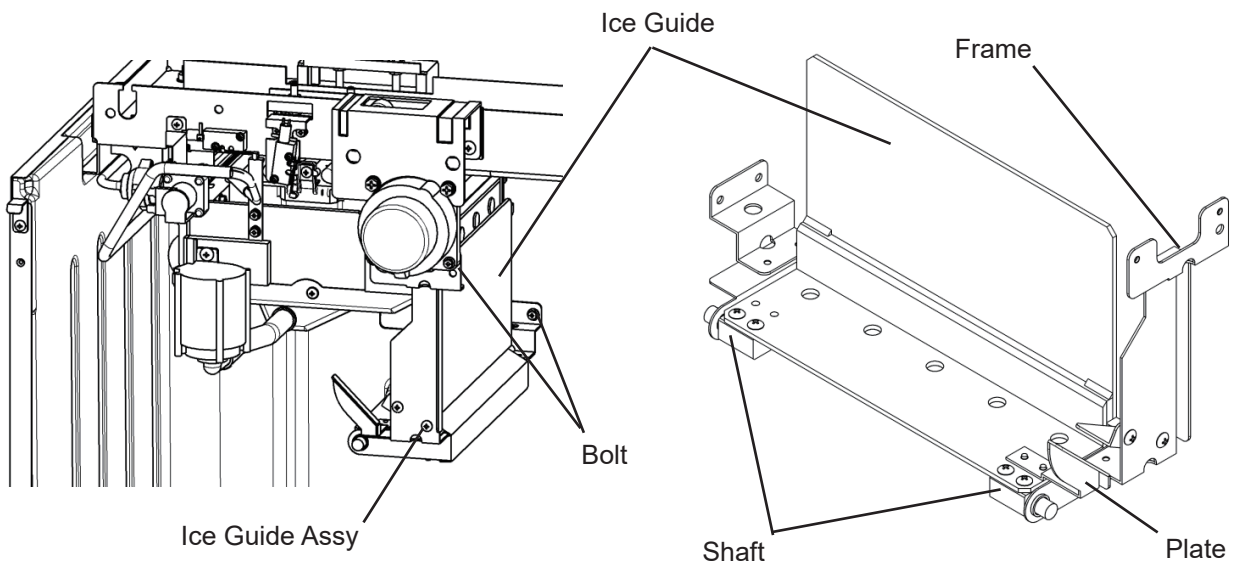

## **Ice Guide Rotation Check**

- 1) When installing the ice guide assembly, check that the ice guide rotates together with the water tank assembly when it opens and closes.
- 2) When the water tank assembly opens, the plastic hex head bolt fixing the spring presses the plate fitted to the ice guide which in turn covers the top of the lower evaporator.
  - \* Spherical ice balls separated from the upper evaporator roll on the ice guide and are led to the bin.
- 3) When the water tank assembly closes, the ice guide is pushed up and returns to its vertical position.

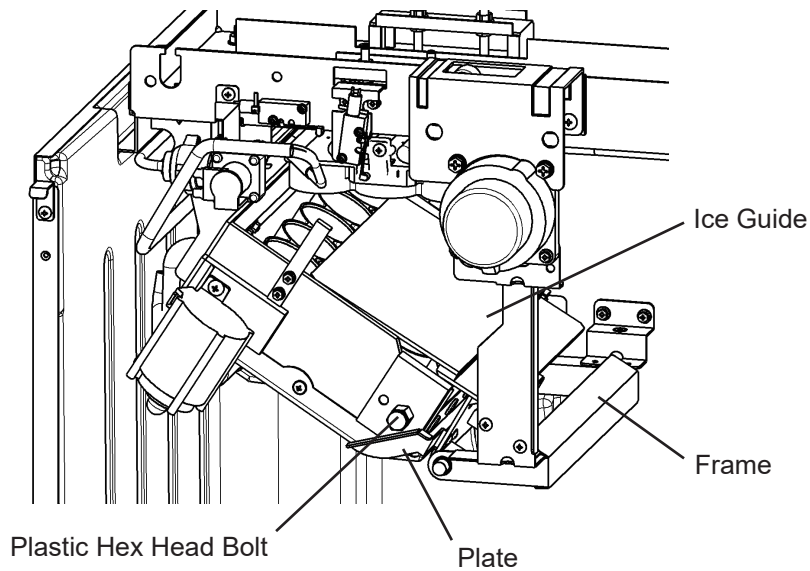

## V. Maintenance

The maintenance schedule below is a guideline. More frequent maintenance may be required depending on water quality, the appliance's environment, and local sanitation regulations.

<b>⚠ WARNING</b>	
<ul style="list-style-type: none"> <li>• Only qualified service technicians should service the appliance.</li> <li>• To reduce the risk of electric shock, do not touch the control switch or plug with damp hands. Make sure the control switch is in the "OFF" position before plugging in or unplugging the appliance.</li> <li>• Move the control switch to the "OFF" position and unplug the appliance from the electrical outlet before servicing.</li> <li>• <b>CHOKING HAZARD:</b> Ensure all components, fasteners, and thumbscrews are securely in place after any maintenance is done to the appliance. Make sure that none have fallen into the storage bin.</li> </ul>	

<b>Maintenance Schedule</b>		
<b>Frequency</b>	<b>Area</b>	<b>Task</b>
Daily	Scoop	Clean the ice scoop using a neutral cleaner. Rinse thoroughly after cleaning.
Bi-Weekly	Air Filters	Inspect. Wash with warm water and neutral cleaner if dirty.
Monthly	External Water Filters	Check for proper pressure and change if necessary.
	Icemaker Exterior	Wipe down with a clean, soft cloth. Use a damp cloth containing a neutral cleaner to wipe off oil or dirt build up. Clean any chlorine staining (rust colored spots) using a non-abrasive cleanser.
Yearly	Icemaker and Dispenser Unit/Ice Storage Bin Liner	Clean and sanitize per the cleaning and sanitizing instructions provided in the instruction manual or maintenance label on the appliance.
	Water Supply Inlet	Close the icemaker water supply line shut-off valve and drain the water system. Clean the water supply inlet screen.
	Condenser	Inspect. Clean if necessary by using a brush or vacuum cleaner. More frequent cleaning may be required depending on location.
	Water Hoses	Inspect the water hoses and clean/replace if necessary.

---

## VI. Preparing the Appliance for Periods of Non-Use

<b><i>NOTICE</i></b>
<ul style="list-style-type: none"><li>• During extended periods of non-use, extended absences, or in sub-freezing temperatures, follow the instructions below to reduce the risk of costly water damage.</li><li>• To prevent damage to the water pump, do not leave the control switch in the "WASH" position for extended periods of time when the water tank is empty.</li></ul>



During extended periods of non-use, extended absences, or in sub-freezing temperatures, follow the instructions below. When the appliance is not used for two or three days under normal conditions, it is sufficient to move the control switch to the "OFF" position.

### 1. Remove the water from the icemaker water supply line:

- 1) Remove the front panel.
- 2) Move the control switch to the "OFF" position.
- 3) Close the icemaker water supply line shut-off valve and open the icemaker water supply line drain valve. See Fig. 3.
- 4) Allow the icemaker water supply line to drain by gravity.
- 5) Attach compressed air or carbon dioxide supply to the icemaker water supply line drain valve.
- 6) Move the control switch to the "ICE" position.
- 7) Blow the icemaker water supply line out using compressed air or carbon dioxide.

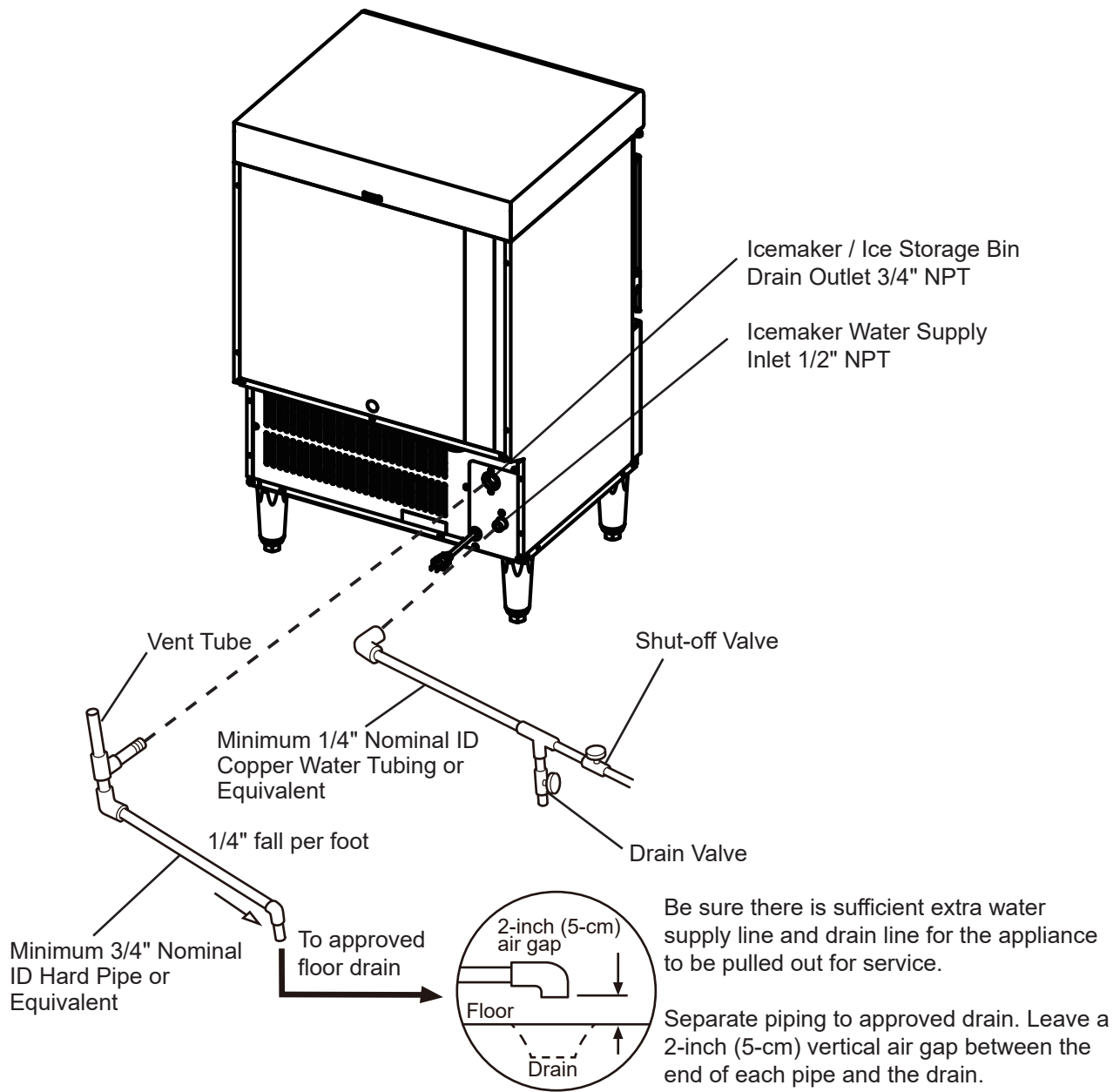

**Fig. 3**

---

## VII. Disposal

The appliance contains refrigerant and must be disposed of in accordance with applicable national, state, and local codes and regulations. Refrigerant must be recovered by properly certified service personnel.

<b><i>IMPORTANT</i></b>	
	The insulation foaming agent used for the unit body contains flammable gas cyclopentane. With this in mind, dispose of the product properly.



## VIII. Technical Information

We reserve the right to make changes in specifications and design without prior notice.

### A. Specification Data

AC SUPPLY VOLTAGE	115/60/1			
AMPERAGE	5.0A ( 5 Min. Freeze AT 104°F / WT 80°F )			
MINIMUM CIRCUIT AMPACITY	N/A			
MAXIMUM FUSE SIZE	N/A			
APPROXIMATE ICE PRODUCTION PER 24 HR. lbs./day ( kg/day )	Ambient Temp. (°F)	Water Temp. (°F)		
		50	70	90
	70	50 (23)	47 (21)	44 (20)
	80	49 (22)	46 (21)	43 (20)
	90	47 (21)	45 (20)	42 (19)
	100	44 (20)	42 (19)	39 (18)
SHAPE OF ICE	Ball φ45mm			
ICE PRODUCTION PER CYCLE	1.48 lbs_(0.67kg), 15pcs.			
APPROXIMATE STORAGE CAPACITY	36 lbs (16.2kg)			
ELECTRIC & WATER CONSUMPTION	90°F / 70°F	70°F / 50°F	See details of	
ELECTRIC W (kWh/100 lbs.)	295(15.7)	270(13.0)	PERFORMANCE DATA	
WATER gal./24HR (gal./100 lbs.)	69(153)	271(542)	NO.SS-	
EXTERIOR DIMENSIONS ( W x D x H )	24.8" x 20.7" x 33.5" (630×525×850mm)			
EXTERIOR FINISH	Stainless Steel Galvanized Steel ( Rear )			
WEIGHT	Net 139 lbs (63kg). Shipping 150 lbs (68kg)			
CONNECTIONS - ELECTRIC	Cord Connection			
- WATER SUPPLY	Inlet R 1/2" (connected at rear side)			
- DRAIN	Outlet Rc3/4" (connected at rear side)			
CUBE CONTROL SYSTEM	Thermistor and Timer			
HARVESTING CONTROL SYSTEM	Hot gas, Thermistor and Timer			
ICE MAKING WATER CONTROL	Timer Controlled			
COOLING WATER CONTROL	N/A			
BIN CONTROL SYSTEM	Mechanical Level Switch with Delay			
COMPRESSOR	Hermetic. Model FF8.5GX			
CONDENSER	Fin and Tube, type Air-cooled			
EVAPORATOR	Tin-plated Copper Tube on Sheet and Cells			
REFRIGERANT CONTROL	Capillary Tube			
REFRIGERANT CHARGE	R134a 7.1 oz. (200 g)			
COMPRESSOR PROTECTION	Auto-reset Overload Protector			
ACCESSORIES - SUPPLIED	Ice Scoop			
- REQUIRED	N/A			
OPERATION CONDITIONS	VOLTAGE RANGE	104 - 127 V		
	AMBIENT TEMP.	45 - 100 °F		
	WATER SUPPLY TEMP.	45 - 90 °F		
	WATER SUPPLY PRESS.	7 - 113 PSIG		

## B. Performance Data

Pressure data is recorded at 5 min. into freezing cycle.

APPROXIMATE ICE PRODUCTION PER 24 HR.	Ambient Temp. (°F)	Water Temp. (°F)		
		50	70	90
	70	50(23)	47(21)	44(20)
	80	49(22)	46(21)	43(20)
	90	47(21)	45(20)	42(19)
lbs./day (kg/day)	100	44(20)	42(19)	39(18)
APPROXIMATE ELECTRIC CONSUMPTION	70	270	280	290
	80	280	285	295
	90	285	295	305
watts	100	300	310	320
APPROXIMATE WATER CONSUMPTION PER 24 HR.	70	271(1.02)	75(0.28)	70(0.27)
	80	254(0.96)	72(0.27)	67(0.25)
	90	242(0.92)	69(0.26)	65(0.25)
gal./day (m <sup>3</sup> /day)	100	227(0.86)	64(0.24)	61(0.23)
FREEZING CYCLE TIME	70	30.7	34.2	36.9
	80	33.7	36.7	40.0
	90	36.1	39.0	42.2
min.	100	39.5	43.3	46.1
HARVEST CYCLE TIME	70	9.7	10.2	10.4
	80	9.3	9.6	9.6
	90	9.0	9.2	9.2
min.	100	8.6	8.7	8.7
HEAD PRESSURE	70	110(0.75)	119(0.82)	126(0.87)
	80	131(0.90)	141(0.97)	149(1.03)
	90	152(1.05)	165(1.14)	171(1.18)
PSIG (MPa)	100	178(1.23)	189(1.30)	197(1.36)
SUCTION PRESSURE	70	17(0.12)	22(0.15)	28(0.19)
	80	20(0.14)	23(0.16)	29(0.20)
	90	20(0.14)	24(0.17)	29(0.20)
PSIG (MPa)	100	23(0.16)	26(0.18)	30(0.21)

TOTAL HEAT OF REJECTION

2600 BTU/h (AT 90°F / WT 70°F)

# C. Wiring Diagram

