



# HOSHIZAKI

## Service Manual

### Modular Crescent Cuber

#### Models

KM-320MAH, MWH

KM-340MAH, MWH

KM-515MAH, MWH, MRH

KM-600MAH

KM-650MAH, MWH, MRH

KM-901MAH, MWH, MRH/3

KM-1100MAH, MWH, MRH

KM-1340MAH, MWH, MRH/3

KM-1601MRH/3



[hoshizakiamerica.com](http://hoshizakiamerica.com)

Number: 73196  
Issued: 4-29-2013  
Revised: 9-21-2016

**⚠ WARNING**

Only qualified service technicians should install and service the appliance. To obtain the name and phone number of your local Hoshizaki Certified Service Representative, visit [www.hoshizaki.com](http://www.hoshizaki.com). No service should be undertaken until the technician has thoroughly read this Service Manual. Failure to service and maintain the appliance in accordance with this manual will adversely affect safety, performance, component life, and warranty coverage. Proper installation is the responsibility of the installer. Product failure or property damage due to improper installation is not covered under warranty.

Hoshizaki provides this manual primarily to assist qualified service technicians in the service of the appliance.

Should the reader have any questions or concerns which have not been satisfactorily addressed, please call, send an e-mail message, or write to the Hoshizaki Technical Support Department for assistance.

Phone: 1-800-233-1940; (770) 487-2331

Fax: 1-800-843-1056; (770) 487-3360

E-mail: [techsupport@hoshizaki.com](mailto:techsupport@hoshizaki.com)

HOSHIZAKI AMERICA, INC.

618 Highway 74 South

Peachtree City, GA 30269

Attn: Hoshizaki Technical Support Department

Web Site: [www.hoshizaki.com](http://www.hoshizaki.com)

**NOTE:** To expedite assistance, all correspondence/communication **MUST** include the following information:

- Model Number \_\_\_\_\_
- Serial Number \_\_\_\_\_
- Complete and detailed explanation of the problem.

## **IMPORTANT**

This manual should be read carefully before the appliance is serviced. Read the warnings and guidelines contained in this manual carefully as they provide essential information for the continued safe use, service, and maintenance of the appliance. Retain this manual for any further reference that may be necessary.

## **CONTENTS**

Important Safety Information .....	6
I. Construction and Water/Refrigeration Circuit Diagram .....	8
A. Construction .....	8
1. Air-Cooled Models (MAH) .....	8
2. Water-Cooled Models (MWH) .....	9
3. Remote Models (MRH/3) .....	10
B. Water/Refrigeration Circuit Diagram .....	11
1. Air-Cooled Models (MAH) .....	11
2. Water-Cooled Models (MWH) .....	12
3. Remote Models (MRH/3) .....	13
II. Sequence of Operation and Service Diagnosis .....	14
A. Sequence of Operation Flow Chart .....	14
1. "E" and "G" Control Board without Harvest Pump Timer Operation .....	14
2. "G" Control Board with Harvest Pump Timer Operation .....	16
B. Service Diagnosis .....	17
1. "E" and "G" Control Board without Harvest Pump Timer Diagnosis .....	18
2. "G" Control Board with Harvest Pump Timer Diagnosis .....	24
C. Control Board Check .....	30
D. Bin Control Check .....	31
1. Thermostatic Bin Control Check .....	31
2. Mechanical Bin Control Check and Cleaning .....	32
E. Float Switch Check and Cleaning .....	34
1. Float Switch Check .....	34
2. Float Switch Cleaning .....	35
F. Thermistor Check .....	36
G. Diagnostic Tables .....	37
III. Controls and Adjustments .....	41
A. Control Board Layout .....	42
1. "E" Control Board .....	42
2. "G" Control Board .....	43
B. LED Lights and Audible Alarm Safeties .....	44
1. "E" Control Board .....	44
2. "G" Control Board .....	45
C. Settings and Adjustments .....	46
1. Default Dip Switch Settings .....	46
a) "E" and "G" Control Board without Harvest Pump Timer Operation .....	46
b) "G" Control Board with Harvest Pump Timer Operation .....	46
2. Harvest Timer (S4 dip switch 1 & 2) .....	46
3. Pump-Out Timer (S4 dip switch 3 & 4) .....	47
4. Pump-Out Frequency Control (S4 dip switch 5 & 6) .....	48

5. Bin Control Selector or Harvest Pump Timer Operation (S4 dip switch 7).....	48
6. Factory Use (S4 dip switch 8).....	49
7. Freeze Timer (S4 dip switch 9 & 10).....	49
8. Float Switch Selector (S5 dip switch 1): "G" Control Board .....	50
9. Refill Counter (S5 dip switch 2 through 5): "G" Control Board .....	50
D. Control Switch .....	50
IV. Refrigeration Circuit and Component Service Information.....	51
A. Refrigeration Circuit Service Information .....	51
B. Component Service Information.....	54
C. Water Regulating Valve Adjustment (water-cooled model) .....	54
V. Maintenance .....	55
VI. Preparing the Appliance for Periods of Non-Use .....	56
VII. Disposal.....	58
VIII. Technical Information.....	59
A. Specification and Performance Data Sheets.....	59
1. KM-320MAH.....	59
2. KM-320MWH .....	60
3. KM-340MAH .....	61
4. KM-340MWH .....	62
5. KM-515MAH .....	63
6. KM-515MWH .....	64
7. KM-515MRH with URC-5F .....	65
8. KM-600MAH .....	66
9. KM-650MAH .....	67
10. KM-650MWH .....	68
11. KM-650MRH with URC-5F .....	69
12. KM-901MAH .....	70
13. KM-901MWH .....	71
14. KM-901MRH with URC-9F.....	72
15. KM-901MRH3 with URC-9F.....	73
16. KM-1100MAH.....	74
17. KM-1100MWH .....	75
18. KM-1100MRH.....	76
19. KM-1340MAH .....	77
20. KM-1340MWH .....	78
21. KM-1340MRH with URC-14F .....	79
22. KM-1340MRH3 with URC-14F .....	80
23. KM-1601MRH with URC-21F.....	81
24. KM-1601MRH with URC-22F.....	82
25. KM-1601MRH3 with URC-21F.....	83
26. KM-1601MRH3 with URC-22F.....	84

C. Wiring Diagrams .....	85
1. Diagrams Without Harvest Pump Timer Relays .....	85
a) KM-320M_H, KM-515M_H, KM-600MAH .....	85
b) KM-650MAH (V-1 and earlier), KM-650MWH (V-1 and earlier), KM-901MAH (B-0 and earlier), KM-901MWH (C-0 and earlier) .....	86
c) KM-650MRH (V-1 and earlier), KM-901MRH (C-0 and earlier) .....	87
d) KM-901MWH (D-1 and later), KM-901MRH (C-1 and later) .....	88
e) KM-1340MAH, KM-1340MWH .....	89
f) KM-1340MRH .....	90
g) KM-1601MRH .....	91
h) KM-901MRH3, KM-1340MRH3, KM-1601MRH3 .....	92
2. Diagrams With Harvest Pump Timer Relays .....	93
a) KM-340M_H .....	93
b) KM-515MAH .....	94
c) KM-650MAH (V-2 to C-2), KM-650MWH (V-2 to C-2), KM-901MAH (B-1 to C-2) .....	95
d) KM-650MAH (D-1 and later), KM-650MWH (D-1 and later), KM-901MAH (D-1 and later) .....	96
e) KM-650MRH (V-2 to C-1) .....	97
f) KM-650MRH (C-2 and later) .....	98
g) KM-1100M_H .....	99

---

## Important Safety Information

Throughout this manual, notices appear to bring your attention to situations which could result in death, serious injury, damage to the appliance, or damage to property.

**⚠ WARNING** Indicates a hazardous situation which could result in death or serious injury.

**NOTICE** Indicates a situation which could result in damage to the appliance or property.

**IMPORTANT** Indicates important information about the use and care of the appliance.

### **⚠ WARNING**

The appliance should be destined only to the use for which it has been expressly conceived. Any other use should be considered improper and therefore dangerous. The manufacturer cannot be held responsible for injury or damage resulting from improper, incorrect, and unreasonable use. Failure to service and maintain the appliance in accordance with this manual will adversely affect safety, performance, component life, and warranty coverage and may result in costly water damage.

**To reduce the risk of death, electric shock, serious injury, or fire, follow basic precautions including the following:**

- Only qualified service technicians should install and service this appliance.
- The appliance must be installed in accordance with applicable national, state, and local codes and regulations.
- Electrical connection must be hard-wired and must meet national, state, and local electrical code requirements. Failure to meet these code requirements could result in death, electric shock, serious injury, fire, or severe damage to equipment.
- The icemaker requires an independent power supply of proper capacity. See the nameplate for electrical specifications. Failure to use an independent power supply of proper capacity can result in a tripped breaker, blown fuses, damage to existing wiring, or component failure. This could lead to heat generation or fire.
- **THE ICEMAKER MUST BE GROUNDED.** Failure to properly ground the icemaker could result in death or serious injury.
- Move the control switch to the "OFF" position and turn off the power supply before servicing. Lockout/Tagout to prevent the power supply from being turned back on inadvertently.
- To reduce the risk of electric shock, do not touch the control switch with damp hands.
- Do not make any alterations to the unit. Alterations could result in electric shock, injury, fire, or damage to the unit.
- The appliance is not intended for use by persons (including children) with reduced physical, sensory, or mental capabilities, or lack of experience and knowledge, unless they have been given supervision or instruction concerning use of the appliance by a person responsible for their safety.

### **⚠ WARNING, continued**

- Children should be properly supervised around this appliance.
- Do not climb, stand, or hang on the appliance or allow children or animals to do so. Serious injury could occur or the appliance could be damaged.
- Do not use combustible spray or place volatile or flammable substances near the appliance. They might catch fire.
- Keep the area around the appliance clean. Dirt, dust, or insects in the appliance could cause harm to individuals or damage to the appliance.

#### **Additional Warning for Remote Models**

- **THE REMOTE CONDENSER UNIT MUST BE GROUNDED.** The power supply and ground connection to the remote condenser unit are supplied from the icemaker. Failure to properly ground the remote condenser unit could result in death or serious injury.
- Move the icemaker control switch to the "OFF" position and turn off the power supply to the icemaker before servicing the remote condenser unit. Lockout/Tagout to prevent the power supply from being turned back on inadvertently.

### ***NOTICE***

- Follow the instructions in this manual carefully to reduce the risk of costly water damage.
- In areas where water damage is a concern, install in a contained area with a floor drain.
- Install the appliance in a location that stays above freezing. Normal operating ambient temperature must be within 45°F to 100°F (7°C to 38°C).
- Do not leave the icemaker on during extended periods of non-use, extended absences, or in sub-freezing temperatures. To properly prepare the icemaker for these occasions, follow the instructions in "VI. Preparing the Appliance for Periods of Non-Use."
- Do not place objects on top of the appliance.
- The dispenser unit/ice storage bin is for ice use only. Do not store anything else in the dispenser unit/ice storage bin.

# I. Construction and Water/Refrigeration Circuit Diagram

## A. Construction

### 1. Air-Cooled Models (MAH)

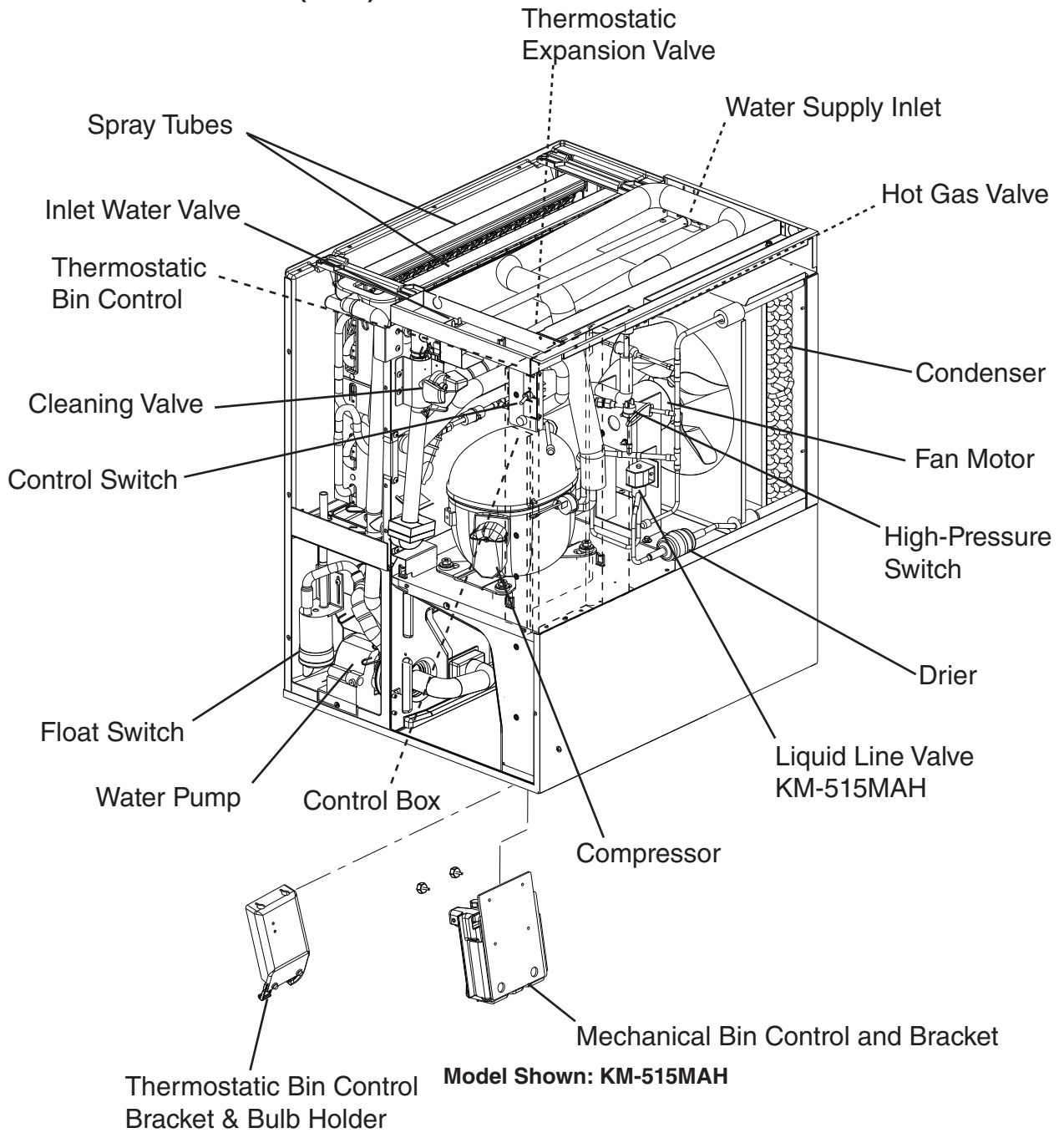

## 2. Water-Cooled Models (MWH)

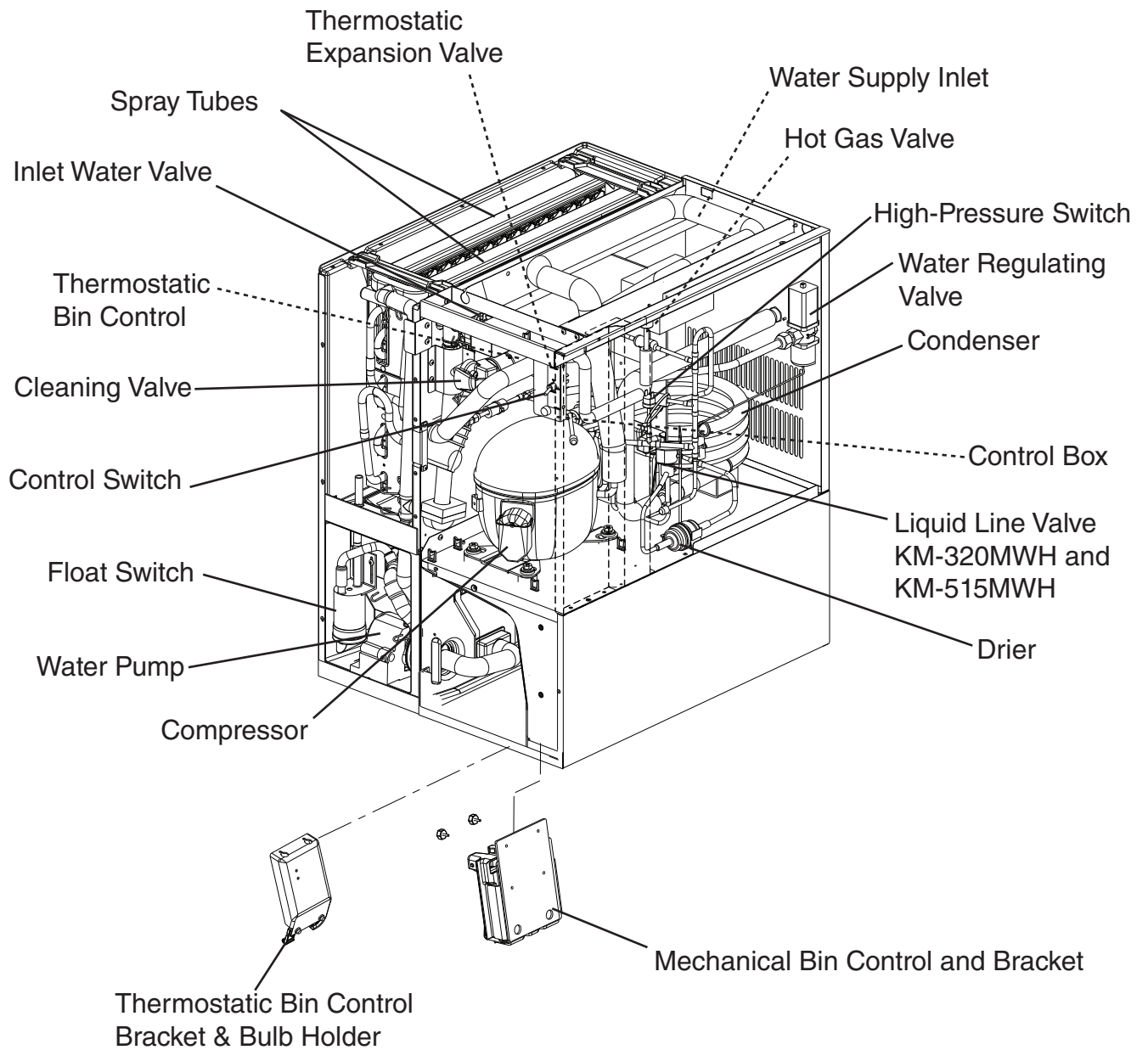

Model Shown: KM-515MWH

**3. Remote Models (MRH/3)**

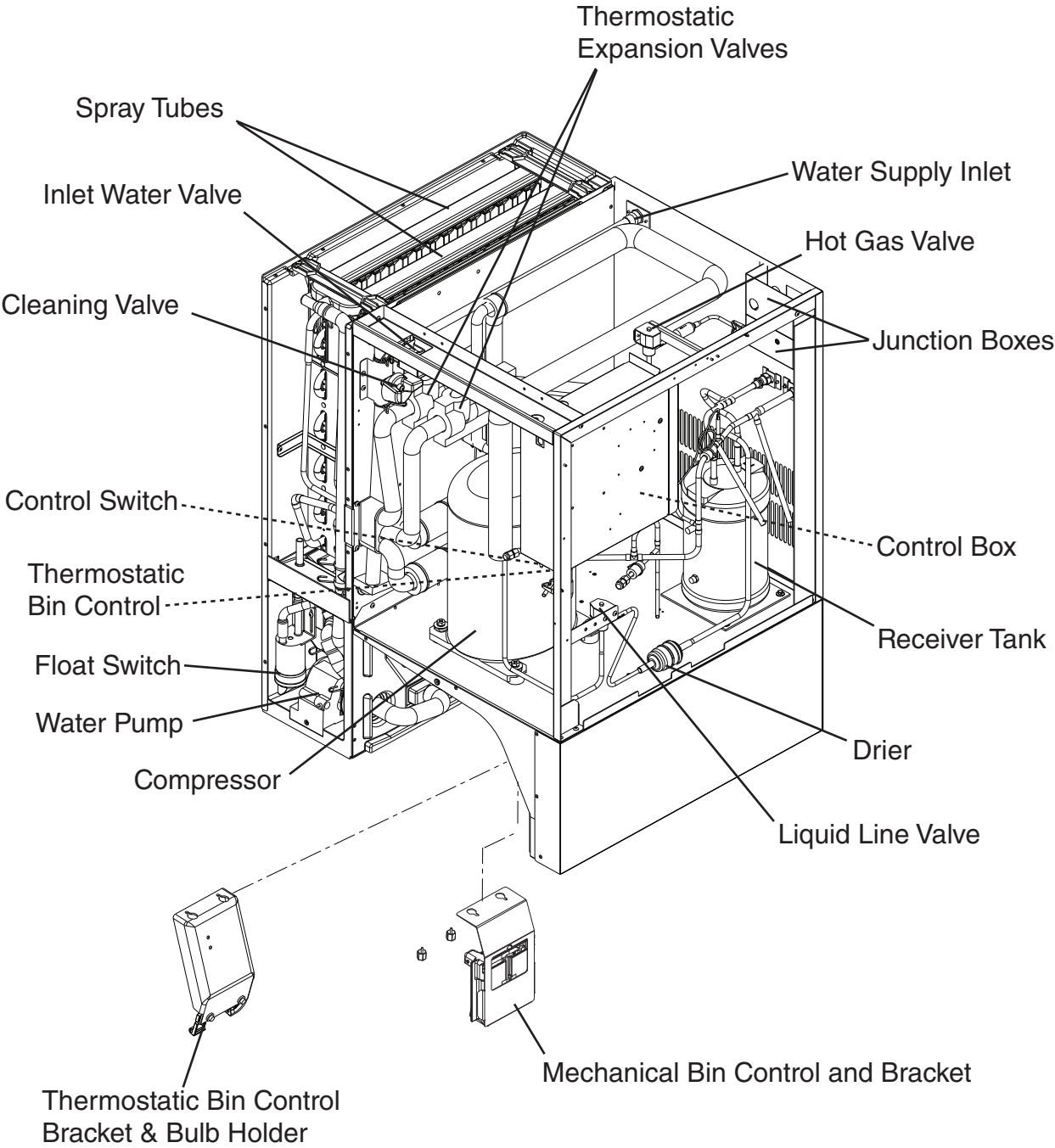

**Model Shown: KM-901MRH**

## B. Water/Refrigeration Circuit Diagram

### 1. Air-Cooled Models (MAH)

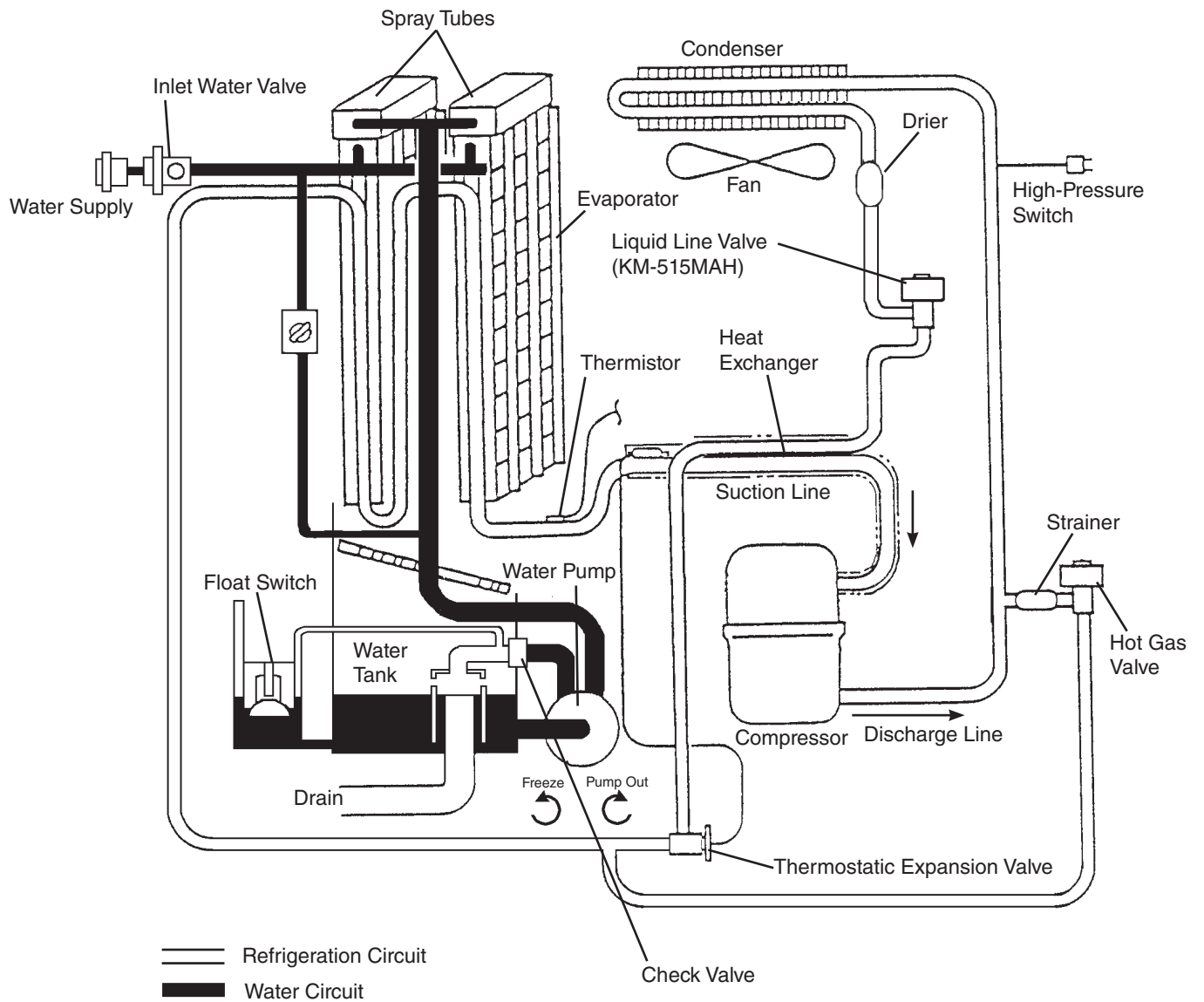

## 2. Water-Cooled Models (MWH)

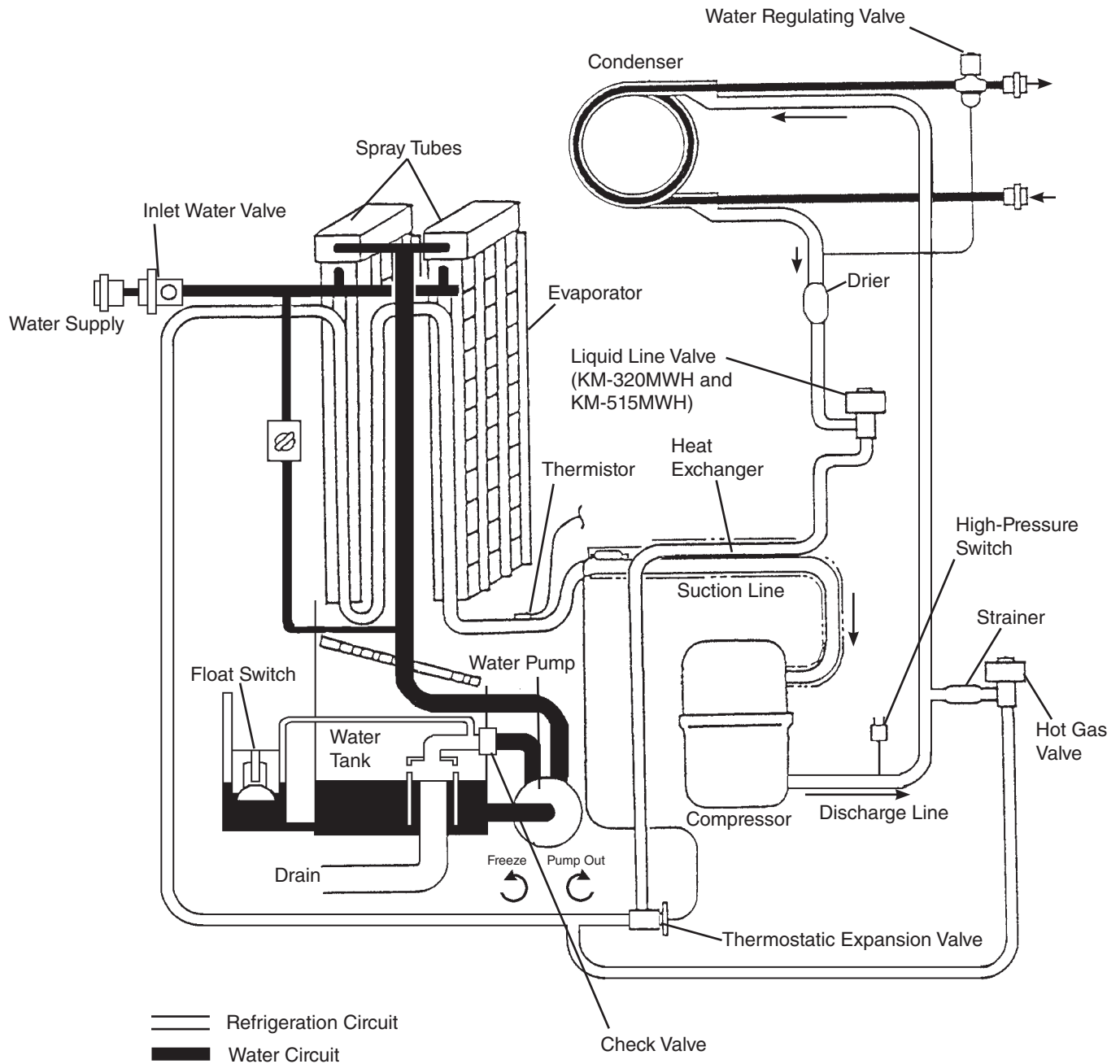

### 3. Remote Models (MRH/3)

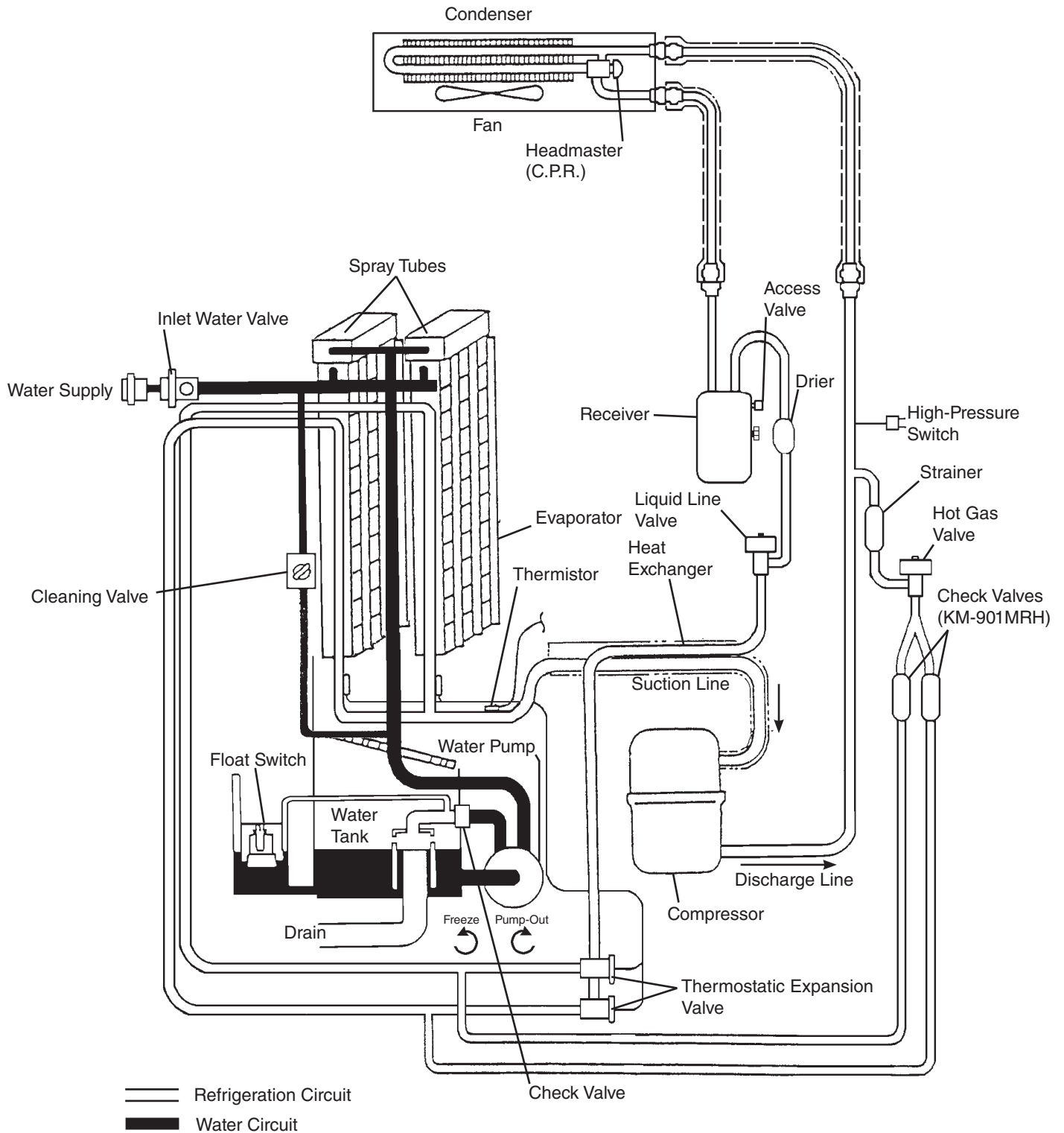

## II. Sequence of Operation and Service Diagnosis

### A. Sequence of Operation Flow Chart

#### 1. "E" and "G" Control Board without Harvest Pump Timer Operation

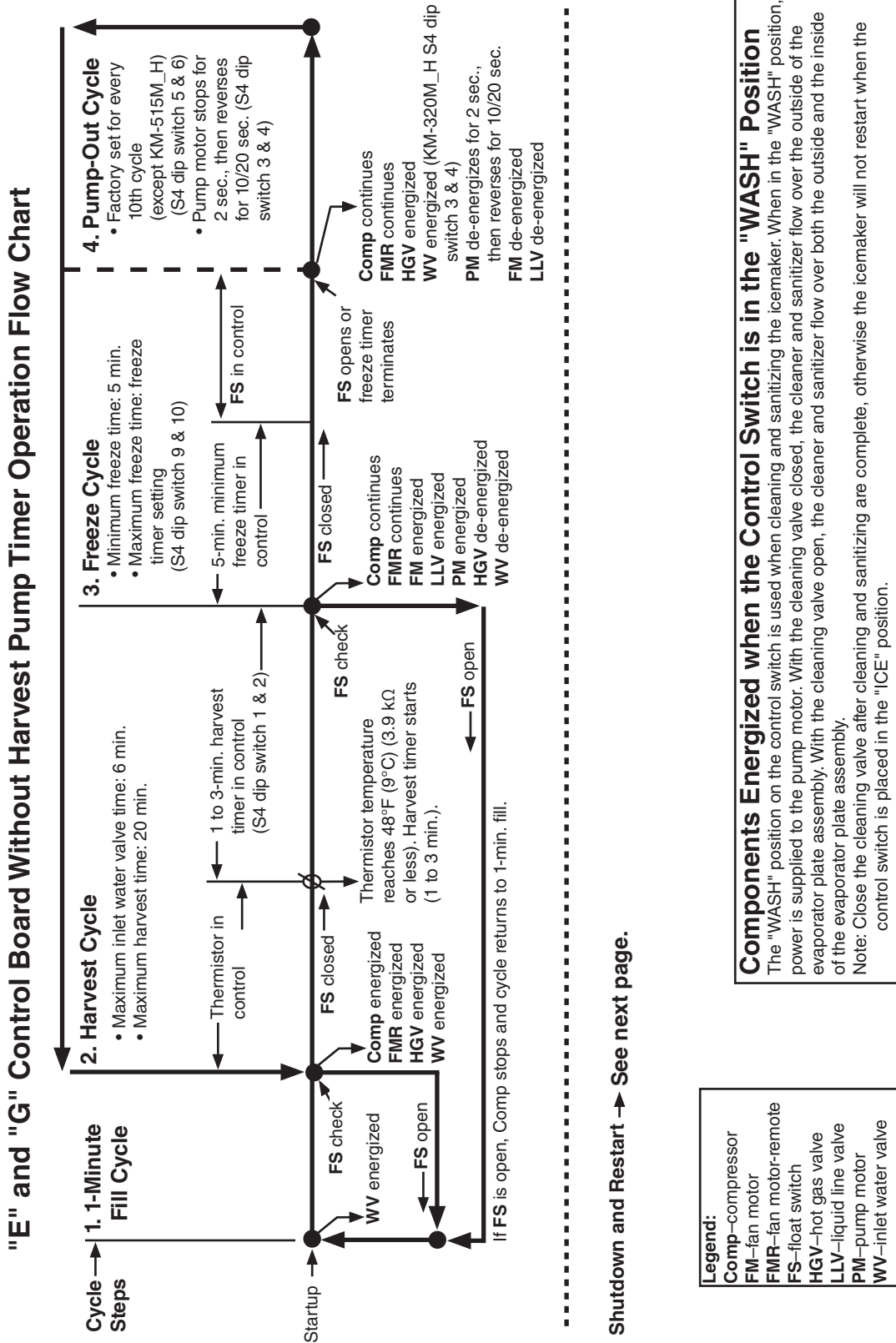

# "E" and "G" Control Board Without Harvest Pump Timer Operation Flow Chart, Continued

## Thermostatic Bin Control Shutdown Sequence Flow Chart

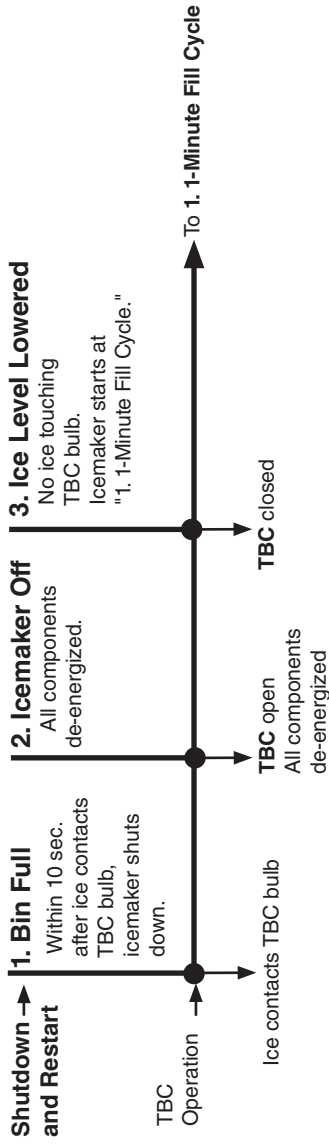

## Mechanical Bin Control Shutdown Sequence Flow Chart

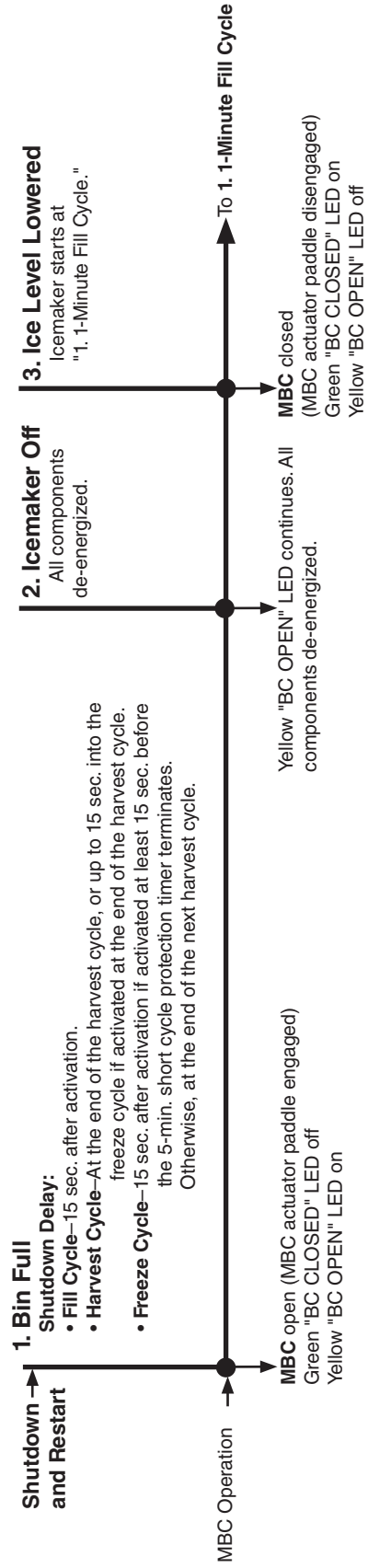

**Legend:**  
MBC—mechanical bin control  
TBC—thermostatic bin control

## 2. "G" Control Board with Harvest Pump Timer Operation

### "G" Control Board With Harvest Pump Timer Operation Sequence Flow Chart

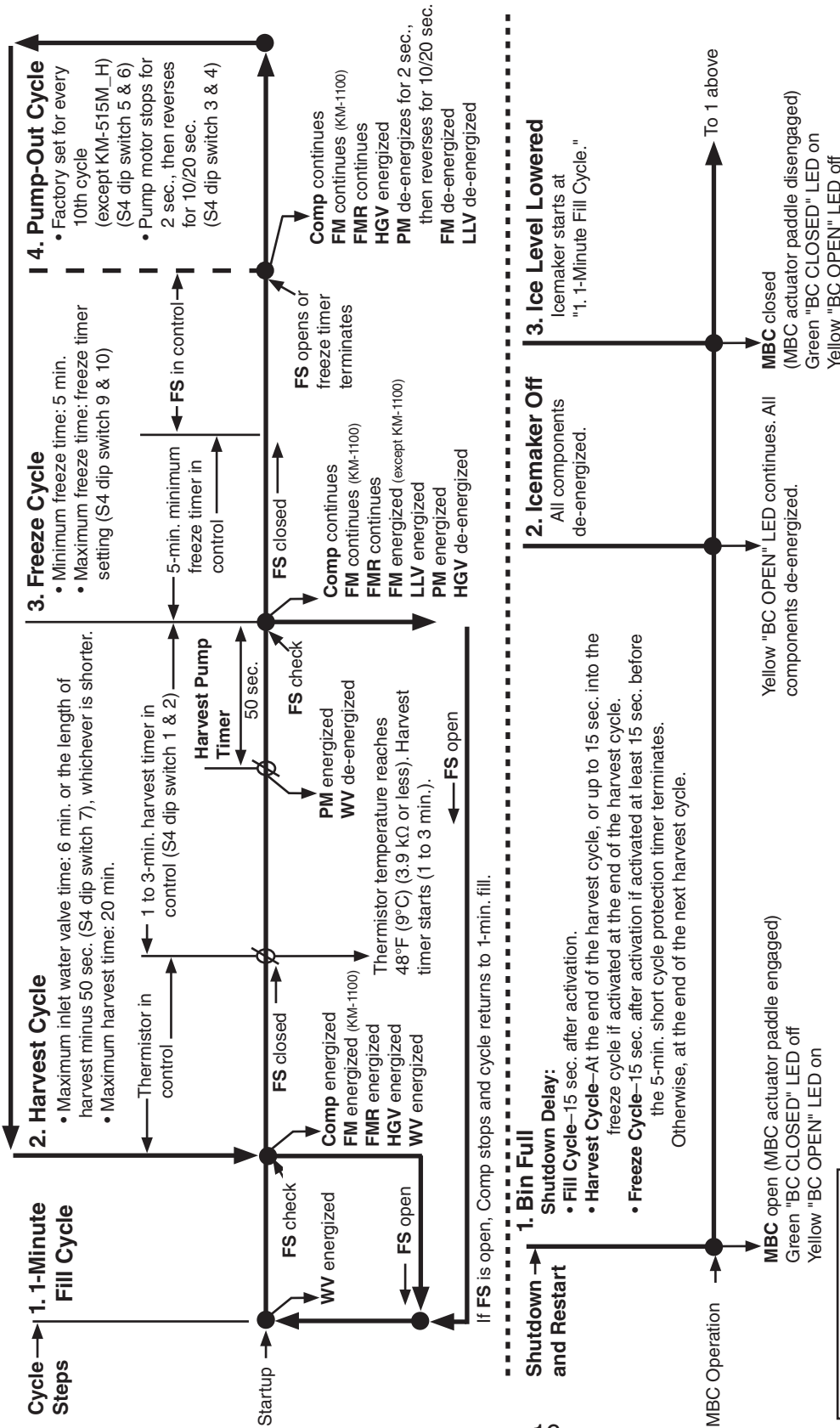

### Components Energized when the Control Switch is in the "WASH" Position

The "WASH" position on the control switch is used when cleaning and sanitizing the icemaker. When in the "WASH" position, power is supplied to the pump motor. With the cleaning valve closed, the cleaner and sanitizer flow over the outside of the evaporator plate assembly. With the cleaning valve open, the cleaner and sanitizer flow over both the outside and the inside of the evaporator plate assembly. Note: Close the cleaning valve after cleaning and sanitizing are complete, otherwise the icemaker will not restart when the control switch is placed in the "ICE" position.

## B. Service Diagnosis

### WARNING

- The appliance should be diagnosed and repaired only by qualified service personnel to reduce the risk of death, electric shock, serious injury, or fire.
- Risk of electric shock. Control switch in "OFF" position does not de-energize all loads Use extreme caution and exercise safe electrical practices.
- Moving parts (e.g., fan blade) can crush and cut. Keep hands clear.
- Before servicing the appliance, move the control switch to the "OFF" position and turn off the power supply.
- **CHOKING HAZARD:** Ensure all components, fasteners, and thumbscrews are securely in place after the appliance is serviced. Make sure that none have fallen into the dispenser unit/ice storage bin.
- Make sure all food zones in the appliance and dispenser unit/ice storage bin are clean after service.

The diagnostic procedure is a sequence check that allows you to diagnose the electrical system and components. Before proceeding, check for correct installation, proper voltage per nameplate, and adequate water supply. Check CB using the steps in "II.C. Control Board Check." Check dip switch settings to assure that S4 dip switch 3, 4, 7, 8, 9, 10 and S5 dip switch 1 through 5 ("G" CB) are in the factory default position. S4 dip switch 1, 2, 5, 6 are cleaning adjustments and the settings are flexible. For factory default settings, see "III.C.1. Default Dip Switch Settings."

Note: • When checking high voltage (115VAC), always choose a white (W) neutral wire to establish a good neutral connection.

- On 208-230/60/1 models with main transformer and 208-230/60/3 models, the appliance neutral (W) is provided through the main transformer. To confirm a good neutral, check for 60VAC from white (W) neutral to ground (GND). If 60VAC is present, neutral is good. If 60VAC is not present, check 208-230VAC main power supply to main transformer. If 208-230VAC is present, check main transformer continuity.
- When checking voltage from the CB K1 connector (10 pin connector), pull CB K1 connector out slightly to allow room for multimeter test leads contact.

- 1) Turn off the power supply, then access the control box. Move the control switch to the "OFF" position. Clear any ice from BC.
- 2) Check that the 115VAC 10A fuse is good.

## 1. "E" and "G" Control Board without Harvest Pump Timer Diagnosis

- 3) **Power On:** Turn on the power supply, then move the control switch to the "ICE" position. A 5-sec. delay occurs.
- "E" Control Board: CB red "POWER OK" LED turns on.
  - "G" Control Board: CB red "POWER OK" LED and green "BC CLOSED" LED turn on.

Note: • CB red "POWER" LED remains on unless the 10.5VAC power supply is interrupted (K2 connector).

- Check CB using the steps in "II.C. Control Board Check."
  - "G" CB with Thermostatic Bin Control: If yellow "BC OPEN" LED is on, check that CB red K4 connector has jumper [4A4883G01](#) properly connected.
  - "G" CB with Mechanical Bin Control: If yellow "BC OPEN" LED is on (indicating a full bin), check MBC. See "II.D.2. Mechanical Bin Control Check and Cleaning."
- a) **Power On Diagnosis:** If CB red "POWER OK" LED is off, confirm closed TBC and 10A fuse is good. If TBC is open, remove ice from bulb and warm bulb in hand. If TBC does not close, replace TBC. See "II.D.1. Thermostatic Bin Control Check." Check for 115VAC at control switch #1 (BR) to neutral (W) then at control switch #2 (P) to neutral (W). If 115VAC is present on #1 (BR) and not on #2 (P), replace control switch. If 115VAC is present on control switch #2 (P), check for 115VAC at HPS (P) to neutral (W) then HPS (BK) to neutral (W). If 115VAC is present at HPS (P) and not at HPS (BK), HPS is open. See HPS Diagnosis below. If 115VAC is present at HPS (BK), check for 10.5VAC at CB K2 #1 red wire to CB K2 #2 red wire. If 10.5VAC is not present, check that the cleaning valve is closed and the interlock switch is closed. Next, check CT continuity. If open replace CT.
- b) **HPS Diagnosis:** Check that the condenser coil is not clogged or restricted. Let refrigeration circuit pressures equalize. If HPS does not reset and pressures are equalized, replace HPS. If pressures are not equalized, reclaim refrigerant and diagnose refrigeration circuit restriction. Check that there are no restrictions in the refrigeration circuit.
- Harvest Cycle: HGV, strainer, or check valve.  
Freeze Cycle: FM, FMR, TXV, HM, LLV, strainer, check valve, drier, and damaged line set or fitting. Also confirm WRV opens in freeze cycle.

Confirm that the location meets installation requirements:

- The icemaker is not intended for outdoor use. Normal operating ambient temperature should be within 45°F to 100°F (7°C to 38°C).
- Allow 6" (15 cm) clearance at rear, sides, and top for proper air circulation and ease of maintenance and/or service should they be required.
- The appliance should not be located in a corrosive environment.

- 4) **1-Minute Fill Cycle – LED 4 is on.** WV energizes. After 1 min., CB checks for a closed FS. If FS is closed, harvest cycle begins. If harvest cycle begins (Comp, HGV, and FMR energize), continue to step 5. If FS is open, WV remains energized through additional 1-min. fill cycles until water enters the water tank and FS closes (low water safety protection during initial start up and at the end of each harvest). **Diagnosis:** Check that water enters the water tank. If not, check that the water supply line shut-off valve is open and screens or external filters are clear. Check for 115VAC at CB K1 #6 (O) to neutral (W). If 115VAC is not present, replace CB. If 115VAC is present, and WV does not energize, check for 115VAC at WV. If 115VAC is present, check coil continuity. If open, replace WV. If the water tank fills, but the appliance fails to start harvest (Comp energized), check for open FS. See "II.E. Float Switch Check and Cleaning." If FS is closed and CB fails to start the harvest cycle after 1 min., replace CB.
- 5) **Initial Harvest Cycle – LEDs 1, 4, and 2 are on.** WV continues. Comp, FMR, and HGV energize. CB monitors the warming of the evaporator via the thermistor located on the suction line. When the thermistor reaches 48°F (9°C), CB reads 3.9 kΩ from the thermistor and turns harvest termination over to the harvest timer (S4 dip switch 1 & 2). The harvest timer has settings of 60, 90, 120, and 180 sec. The pump-out timer (S4 dip switch 3 & 4) acts in place of the harvest timer during cycles with a pump-out (S4 dip switch 5 & 6). WV remains energized during harvest for a maximum of 6 min. or the length of harvest, whichever is shorter.
- a) **Comp Diagnosis:** Check that evaporator is warming. If not, confirm that Comp energizes. If not, check for 115VAC at CB K1 #1 or #9 (V) to neutral (W). If 115VAC is not present, check for 115VAC at CB K1 #7 or #10 (BR) to neutral (W). If 115VAC is present at #7 or #10 (BR) and not at #1 or #9 (V), replace CB. If 115VAC is present, check for 115VAC at CR or MC solenoid. If 115VAC is present, confirm contacts are closed. If not, replace CR or MC. If CR or MC contacts are closed, check Comp external overload, Comp start and run capacitors, Comp start relay, and Comp motor winding.
- b) **HGV Diagnosis:** If Comp is energized and evaporator is not warming, check that HGV energizes and opens. Check for 115VAC at CB K1 #2 (P) to neutral (W). If 115VAC is not present, replace CB. If 115VAC is present, check for 115VAC at HGV coil and check HGV coil continuity. Replace as needed.
- c) **LLV Diagnosis:** Confirm that LLV is de-energized and closed (not bypassing). If energized, replace CB. If de-energized and bypassing, replace LLV.
- d) **WRV Diagnosis:** Confirm WRV is not leaking by.

e) **Initial Harvest Cycle Termination Diagnosis:** When the thermistor reaches 48°F (9°C), CB reads 3.9 kΩ from the thermistor and turns harvest termination over to the harvest timer (S4 dip switch 1 & 2). Check discharge line temperature. For a thermistor check, see "II.F. Thermistor Check." If 1-min. fill cycle starts after harvest timer terminates, check that FS is clean and operating properly, see "II.E. Float Switch Check and Cleaning." If FS is closed, CB proceeds to the next cycle. If not, replace CB.

Note: The minimum total time allowed by CB for a complete harvest cycle is 2 min.  
Maximum harvest time allowed is 20 min.

**NOTICE! On models with "G" control board and no harvest pump timer relays, S4 dip switch 7 must remain off. Otherwise, PM energizes in reverse direction the last 50 seconds of harvest and empties water from water tank.**

- 6) **Freeze Cycle – LED 1 is on.** Comp and FMR continue. PM, FM, and LLV energize. WV and HGV de-energize. Appliance is held in freeze by a 5-min. short cycle protection timer. After 5-min. timer terminates and FS opens, freeze cycle terminates.
- a) **Freeze Cycle Diagnosis:** Confirm Comp and FMR continue. Confirm that PM, FM, and LLV energize. Confirm WRV opens. Next, confirm WV and HGV de-energize. During the first 5 min. of freeze, confirm evaporator is cooling. If not, confirm WV de-energized (not leaking by), HGV de-energized (not bypassing), LLV and FM energize, TXV and HM operate correctly, WRV opens, Comp is efficient, and refrigerant charge is correct. See "VIII.A. Specification Sheet" and "VIII.B. Performance Data."
- b) **Comp and FMR Diagnosis:** If Comp and FMR de-energize once freeze begins, check that appliance has not shut off on HPS ("POWER OK" LED off). If so, check "3)b) HPS Diagnosis" above. If "POWER OK" LED is on, check for 115VAC at CB K1 #1 (V) or #9 (V) to neutral (W). If 115VAC is not present and LED 1 is on, replace CB. If 115VAC is present, check for 115VAC at CR or MC coil. If 115VAC is present, check CR or MC coil and contact continuity. Replace as needed. If CR or MC is ok, check Comp external overload, start relay, and start and run capacitors. Next, check Comp motor winding continuity. If Comp is energized but evaporator is not cooling, check for an inefficient Comp. See "VIII.B. Performance Data." If Comp is energized but FMR is not, check for 115VAC at the FMR junction box. If 115VAC is not present, check icemaker wiring connections. If 115VAC is present, check for voltage at condenser unit. If 115VAC is not present, check field wiring connections. If 115VAC is present, check FMR capacitor, motor winding, and fan blade for binding.
- c) **WV and HGV Diagnosis:** If WV is energized, check for 115VAC at CB K1 #6 (O) to neutral (W). If 115VAC is present after PM energizes, replace CB. If 115VAC is not present, replace WV (bypassing). If HGV did not de-energize, check for 115VAC at CB K1 #2 (P) to neutral (W). If 115VAC is present after PM energizes, replace CB. If 115VAC is not present, replace HGV (bypassing).

- d) **PM Diagnosis:** Confirm water is flowing over evaporator from PM and not WV. If PM de-energizes once freeze begins, check for 115VAC at CB K1 #4 (R) to neutral (W). If 115VAC is not present, replace CB. If 115VAC is present and PM is de-energized, check for 115VAC at control switch #5 (R) to neutral (W). If 115VAC is present at CB K1 #4 (R) and not at control switch #5 (R), check control switch continuity between #5 (R) and #4 (R). Replace as needed. If 115VAC is present at control switch #5 (R) to neutral (W), check PM capacitor and motor winding continuity.
- e) **FM and LLV Diagnosis:** If FM or LLV does not energize, check for 115VAC at CB K1 #3 (BK) to neutral (W). If 115VAC is not present, replace CB. If 115VAC is present: For FM, check capacitor, motor winding, and blade for binding. For LLV, check coil voltage and continuity.
- f) **Refrigerant Pressures, HM, and TXV Diagnosis:** If evaporator is still not cooling, check refrigerant pressures. See "VIII.B. Performance Data." Next, check HM operation. If refrigeration pressures are above HM setpoint and HM is bypassing, replace HM. Check TXV for proper operation. Remove TXV bulb and hold it in your hand, refrigerant low-side pressure should rise, place TXV bulb in ice water, refrigerant low-side pressure should drop. A 10 to 15 pound pressure swing between warm and cold conditions indicate a good TXV. If a 10 to 15 pound swing is not present, replace TXV.
- g) **WRV Diagnosis:** WRV is factory set and generally no adjustment is required. If WRV fails to open in freeze, check for proper refrigerant pressures. See "VIII.B. Performance Data." If refrigerant pressures are correct and WRV does not open, adjust or replace as needed. See "IV.C. Water Regulating Valve Adjustment (water-cooled models)."
- h) **Freeze Termination Diagnosis:** After 5 min. in freeze, disconnect CB K5 FS connector. 15 sec. later appliance should switch out of the freeze cycle (15 second delay after FS opens before terminating the freeze cycle). If appliance remains in freeze longer than 15 sec. after FS removed, replace CB. If appliance switches with FS removed but would previously not switch out of freeze with FS connected (long freeze - 3 beep alarm), see "II.E. Float Switch Check and Cleaning."

Note: Normal freeze cycle will last 20 to 40 min. depending on model and conditions. Cycle times and pressures should follow performance data provided in this manual. See "VIII.B. Performance Data."

- i) **Short Freeze Cycle Diagnosis:** Confirm water tank fills and overflows during 1 min. fill and harvest cycles. If not, check water supply filters, shut-off valve, WV screen. If water tank empties before 5 min. timer terminates and freeze cycle is short, check that CV is not leaking by (water flowing down the potable drain). If CV is leaking by, remove and clean CV, replace rubber seat and spring if necessary. If water tank is full, see "II.E. Float Switch Check and Cleaning" for erratic operating FS.

- 7) **Pump-Out Cycle – LEDs 1, 3, and 2 are on (10/20 second pump-out).** Timing of the first pump-out is dependent on CB. "E" CB first pump-out is after the first freeze cycle. "G" CB first pump-out is determined by S4 dip switch 5 & 6. See the table below.

"E" & "G" Control Board Settings			1st Pump-Out	
S4 Dip Switch Setting		Pump-Out Frequency	"E" Control Board	"G" Control Board
No. 5	No. 6			
OFF	OFF	Every cycle	After 1st freeze cycle	After 2nd freeze cycle
ON	OFF	Every 2 cycles		After 3rd freeze cycle
OFF	ON	Every 5 cycles		After 6th freeze cycle
ON	ON	Every 10 cycles		After 11th freeze cycle

Comp and FMR continue, HGV energizes. If S4 dip switch 3 & 4 are set to 3 off and 4 on, LED 4 turns on and WV energizes. FM and LLV de-energize. PM stops for 2 sec., then reverses for 10/20 sec. depending on pump-out timer (S4 dip switch 3 & 4) setting. When the pump-out timer terminates, pump-out is complete. The pump-out frequency control (S4 dip switch 5 & 6) is factory set, and generally no adjustment is required. However, the pump-out frequency control can be set to have a pump-out occur every cycle, or every 2, 5, or 10 cycles. For details, see "III.C.4. Pump-Out Frequency Control (S4 dip switch 5 & 6)."

**Pump-Out Diagnosis:** In the freeze cycle before pump-out (see table above), disconnect CB black K5 connector (FS connector) after 5 min. of freeze. Check that PM stops and re-starts and water is flowing down the drain through CV. If PM does not stop and re-start, check that CB LEDs 1, 3, and 2 are on. If not, replace CB. If LEDs 1, 3, and 2 are on and PM does not energize, check for 115VAC at CB K1 #5 (DBU) to neutral (W). If 115VAC is not present, replace CB. If 115VAC is present, make sure the drain line is not clogged and that CV is clean and operating properly.

Confirm FM and LLV de-energize. If FM or LLV is energized with LEDs 1, 3, and 2 on, replace CB.

- 8) **Normal Harvest Cycle** – Same as the initial harvest cycle. Return to step 5 above.  
 Note: Appliance continues to cycle until TBC or MBC is satisfied or power is turned off.  
 The appliance always restarts at the 1-min. fill cycle.

## 9) Shutdown

### a) **Thermostatic Bin Control (TBC):**

When the appliance is running, hold ice in contact with the thermostatic bulb. TBC switch opens within 10 sec., shutting down the appliance. TBC is factory set, and generally no adjustment is required. However, adjustment may be needed in some conditions, particularly at higher altitude locations.

<b>NOTICE</b>
<ul style="list-style-type: none"><li>• On "E" control boards, do not adjust S4 dip switch 7 out of the factory default position. This dip switch must be left in the factory default position or the appliance will not operate correctly.</li><li>• On "G" control boards, CB red K4 connector jumper (<a href="#">4A4883G01</a>) must be in place. Diagnosis: See "II.D.1. Thermostatic Bin Control Check."</li></ul>

### b) **Mechanical Bin Control:**

See "II.D.2. Mechanical Bin Control Check and Cleaning."

Legend: **BC**—bin control; **CB**—control board; **Comp**—compressor; **CV**—check valve; **FM**—fan motor; **FMR**—fan motor-remote; **FS**—float switch; **HGV**—hot gas valve; **HM**—headmaster (C.P.R.); **HPS**—high-pressure switch; **LLV**—liquid line valve; **MBC**—mechanical bin control; **PM**—pump motor; **TBC**—thermostatic bin control; **TXV**—thermostatic expansion valve; **WRV**—water regulating valve; **WV**—inlet water valve

## 2. "G" Control Board with Harvest Pump Timer Diagnosis

- 3) **Power On:** Turn on the power supply, then move the control switch to the "ICE" position. A 5-sec. delay occurs. CB red "POWER OK" LED and green "BC CLOSED" LED turn on. If yellow "BC OPEN" LED is on (indicating a full bin), check MBC. Move ice away from MBC actuator paddle. If yellow "BC OPEN" LED stays on, see "II.D.2. Mechanical Bin Control (MBC) Check."

Note: • CB red "POWER OK" LED remains on unless the 10.5VAC power supply is interrupted (K2 connector).

- Check CB using the steps in "II.C. Control Board Check."
  - Confirm CB green "BC CLOSED" LED is on. If CB yellow "BC OPEN" LED is on, remove ice from BC. If no ice is around BC and yellow "BC OPEN" LED is on, see "II.D.2. Mechanical Bin Control (MBC) Check."
- a) **Power On Diagnosis:** If CB red "POWER OK" LED is off, confirm 10A fuse is good. Check for 115VAC at control switch #1 (BR) to neutral (W) then at control switch #2 (P) to neutral (W). If 115VAC is present on #1 (BR) and not on #2 (P), replace control switch. If 115VAC is present on control switch #2 (P), check for 115VAC at HPS (P) to neutral (W) then HPS (BK) to neutral (W). If 115VAC is present at HPS (P) and not at HPS (BK), HPS is open. See HPS Diagnosis below. If 115VAC is present at HPS (BK), check for 10.5VAC at CB K2 #1 red wire to CB K2 #2 red wire. If 10.5VAC is not present, check that the cleaning valve is closed and the interlock switch is closed. Next, check CT continuity. If open, replace CT.
- b) **HPS Diagnosis:** Check that the condenser coil is not clogged or restricted. Let refrigeration circuit pressures equalize. If HPS does not reset and pressures are equalized, replace HPS. If pressures are not equalized, reclaim refrigerant and diagnose refrigeration circuit restriction. Check that there are no restrictions in the refrigeration circuit.  
Harvest Cycle: HGV, strainer, or check valve.  
Freeze Cycle: FM, FMR, TXV, WRV, HM, LLV, strainer, check valve, drier, and damaged line set or fitting.

Confirm that the location meets installation requirements:

- The appliance is not intended for outdoor use. Normal operating ambient temperature should be within 45°F to 100°F (7°C to 38°C).
- Allow 6" (15 cm) clearance at rear, sides, and top for proper air circulation and ease of maintenance and/or service should they be required.
- The appliance should not be located in a corrosive environment.

- 4) **1-Min. Fill Cycle – LED 4 is on.** WV and X11 relay energize. After 1 min., CB checks for a closed FS. If FS is closed, the harvest cycle begins. If harvest cycle begins (Comp, HGV, FMR energized), continue to step 5a. If FS is open, WV remains energized through additional 1-min. fill cycles until water enters the water tank and FS closes (low water safety protection during initial start up and at the end of each harvest).  
**Diagnosis:** Check that water enters the water tank. If not, check that the water supply line shut-off valve is open and screens or external filters are clear. Check for 115VAC at CB K1 #6 (O) to neutral (W). If 115VAC is not present, replace CB. If 115VAC is present, and WV does not energize, check for 115VAC at WV. If 115VAC is present, check coil continuity. If open, replace WV. If the water tank fills, but the appliance fails to start harvest (Comp energized), check for open FS. See "II.E. Float Switch Check and Cleaning." If FS is closed and CB fails to start the harvest cycle after 1 min., replace CB.
- 5a) **Initial Harvest Cycle – LEDs 1, 4, and 2 are on.** WV and X11 relay continue. Comp, FMR, HGV, and X10 relay energize. CB monitors the warming of the evaporator via the thermistor located on the suction line. When the thermistor reaches 48°F (9°C), CB reads 3.9 kΩ from the thermistor and turns harvest termination over to the harvest timer (S4 dip switch 1 & 2). The harvest timer has settings of 60, 90, 120, and 180 sec. The pump-out timer (S4 dip switch 3 & 4) acts in place of the harvest timer during cycles with a pump-out (S4 dip switch 5 & 6). WV and X11 relay are energized during harvest for a maximum of 6 min. or the length of harvest minus 50 sec., whichever is shorter. 50 sec. before harvest terminates, PM energizes. See step 5b below.
- a) **Comp Diagnosis:** Check that evaporator is warming. If not, confirm that Comp energizes. If not, check for 115VAC at CB K1 #1 or #9 (V) to neutral (W). If 115VAC is not present, check for 115VAC at CB K1 #7 or #10 (BR) to neutral (W). If 115VAC is present at #7 or #10 (BR) and not at #1 or #9 (V), replace CB. If 115VAC is present, check for 115VAC at CR or MC solenoid. If 115VAC is present, confirm contacts are closed. If not, replace CR or MC. If CR or MC contacts are closed, check Comp external overload, Comp start and run capacitors, Comp start relay, and Comp motor winding. If Comp is energized and evaporator is not warming, check that HGV energizes and opens. Check for 115VAC at CB K1 #2 (P) to a neutral (W). If 115VAC is not present and LED 2 is on, replace CB. If 115VAC is present, check coil voltage and continuity. Replace as needed. Confirm that LLV is de-energized and closed (not bypassing). If energized, replace CB. If de-energized and bypassing, replace LLV. Confirm WRV is not leaking by. If evaporator is warming, PM energizes for the last 50 sec. of harvest.
- b) **HGV Diagnosis:** If Comp is energized and evaporator is not warming, check that HGV energizes and opens. Check for 115VAC at CB K1 #2 (P) to neutral (W). If 115VAC is not present, replace CB. If 115VAC is present, check for 115VAC at HGV coil and check HGV coil continuity. Replace as needed.
- c) **LLV Diagnosis:** Confirm that LLV is de-energized and closed (not bypassing). If energized, replace CB. If de-energized and bypassing, replace LLV.
- d) **WRV Diagnosis:** Confirm WRV is not leaking by.

5b) **Harvest Pump Timer – LEDs 1, 3, and 2 are on.** When the thermistor reaches 48°F (9°C), CB reads 3.9 kΩ from the thermistor and turns harvest termination over to the harvest timer (S4 dip switch 1 & 2). 50 sec. before the harvest timer terminates, LED 3 turns on and PM energizes. Comp, FMR, HGV, and X10 relay continue. LED 4 turns off, WV and X11 relay de-energize.

**Diagnosis:** Place a thermometer on the suction line next to the thermistor. Has it warmed to 48°F (9°C) or warmer? Confirm thermistor status. See "II.F. Thermistor Check." If the thermistor reading is in proper range, dip switch 7 is on, and PM does not energize 50 sec. before harvest terminates, replace CB. If WV continues, check for 115VAC at CB K1 #6 (O). If 115VAC is present, and LED 4 is off, replace CB. If LED 3 is on and PM is not energized, check for 115VAC at CB K1 #5 (DBU). If 115VAC is not present, replace CB. If 115VAC is present and PM is not energized, check for 115VAC at X10 relay terminal #7 (Y) to neutral (W). If 115VAC is not present, check for 115VAC at X10 relay terminal #3 (P) to neutral (W) and X10 relay terminal #5 (Y) to neutral (W). If 115VAC is present on terminal #3 (P) and not on terminal #5 (Y), replace X10 relay. If 115VAC is present on X10 relay terminal #7 (Y) and PM is not energized, check for 115VAC at X10 relay terminal #4 (R) to neutral (W) and terminal #6 (DBU) to neutral (W). If 115VAC is present on terminal #6 (DBU) and not on terminal #4 (R), replace X10 relay. If 115VAC is present on X10 relay terminal #4 (R), check control switch contact continuity between terminals #4 (R) and #5 (R). If contacts are open, replace control switch. If contacts are closed and 115VAC is present between control switch terminal #5 (R) and neutral (W), check PM capacitor and motor winding continuity.

5c) **Initial Harvest Cycle Termination Diagnosis:** When the thermistor reaches 48°F (9°C), CB reads 3.9 kΩ from the thermistor and turns harvest termination over to the harvest timer (S4 dip switch 1 & 2). Check discharge line temperature. For a thermistor check, see "II.F. Thermistor Check." If 1-min. fill cycle starts after harvest timer terminates, check that FS is clean and operating properly, see "II.E. Float Switch Check and Cleaning." If FS is closed, CB proceeds to the next cycle. If not, replace CB.

Note: The minimum total time allowed by CB for a complete harvest cycle is 2 min.

Maximum harvest time allowed is 20 min.

**NOTICE! S4 dip switch 7 must remain on. Otherwise, PM will not energize during the last 50 sec. of harvest.**

- 6) **Freeze Cycle – LED 1 is on.** Comp, FMR, and PM continue. FM and LLV energize. HGV and X10 relay de-energize. Appliance is held in freeze by a 5-min. short cycle protection timer. After 5-min. timer terminates and FS opens, freeze cycle terminates. Note: PM power supply switches from CB K1 #5 (DBU) in harvest to K1 #4 (R) in freeze.
- a) **Freeze Cycle Diagnosis:** Confirm Comp, FMR, and PM continue. Confirm that FM and LLV energize. Confirm WRV opens. Next, confirm HGV and X10 relay de-energize. During the first 5 min. of freeze, confirm evaporator is cooling. If not, confirm WV de-energized (not leaking by), HGV de-energized (not bypassing), LLV and FM energize, TXV and HM operate correctly, WRV opens, Comp is efficient, and refrigerant charge is correct. See "VIII.A. Specification Sheet" and "VIII.B. Performance Data."
- b) **Comp and FMR Diagnosis:** If Comp and FMR de-energize once freeze begins, check that appliance has not shut off on HPS ("POWER OK" LED off). If so, check "3)b) HPS Diagnosis" above. If "POWER OK" LED is on, check for 115VAC at CB K1 #1 (V) or #9 (V) to neutral (W). If 115VAC is not present and LED 1 is on, replace CB. If 115VAC is present, check for 115VAC at CR or MC coil. If 115VAC is present, check CR or MC coil and contact continuity. Replace as needed. If CR or MC is okay, check Comp start relay and start and run capacitors. Next, check Comp motor winding continuity. If Comp is energized but evaporator is not cooling, check for an inefficient Comp. See "VIII.B. Performance Data." If Comp is energized but FMR is not, check for 115VAC at the FMR junction box. If 115VAC is not present, check icemaker wiring connections. If 115VAC is present, check for voltage at condenser unit. If 115VAC is not present, check field wiring connections. If 115VAC is present, check FMR capacitor, motor winding, and fan blade for binding.
- c) **WV and HGV Diagnosis:** If WV is energized, check for 115VAC at CB K1 #6 (O) to neutral (W). If 115VAC is present after PM energizes in harvest cycle, replace CB. If 115VAC is not present, replace WV (bypassing). If HGV did not de-energize at the end of harvest, check for 115VAC at CB K1 #2 (P) to neutral (W). If 115VAC is present 50 sec. after PM energizes, replace CB. If 115VAC is not present, replace HGV (bypassing).
- d) **PM Diagnosis:** Confirm water is flowing over evaporator from PM and not WV. If PM de-energizes once freeze begins, check for 115VAC at CB K1 #4 (R) to neutral (W). If 115VAC is not present, replace CB. If 115VAC is present and PM is de-energized, check for 115VAC at control switch #5 (R) to neutral (W). If 115VAC is present at CB K1 #4 (R) and not at control switch #5 (R), check control switch continuity between #5 (R) and #4 (R). Replace as needed. If 115VAC is present at control switch #5 (R) to neutral (W), check PM capacitor and motor winding continuity.
- e) **FM and LLV Diagnosis:** If FM or LLV does not energize, check for 115VAC at CB K1 #3 (BK) to neutral (W). If 115VAC is not present, replace CB. If 115VAC is present: For FM, check capacitor, motor winding, and blade for binding. For LLV, check coil voltage and continuity.

- f) **Refrigerant Pressures, HM, and TXV Diagnosis:** If evaporator is still not cooling, check refrigerant pressures. See "VIII.B. Performance Data."  
 Next, check HM operation. If refrigeration pressures are above HM setpoint and HM is bypassing, replace HM. Check TXV for proper operation. Remove TXV bulb and hold it in your hand, refrigerant low-side pressure should rise, place TXV bulb in ice water, refrigerant low-side pressure should drop. A 10 to 15 pound pressure swing between warm and cold conditions indicate a good TXV. If a 10 to 15 pound swing is not present, replace TXV.
- g) **WRV Diagnosis:** WRV is factory set and generally no adjustment is required. If WRV fails to open in freeze, check for proper refrigerant pressures. See "VIII.B. Performance Data." If refrigerant pressures are correct and WRV does not open, adjust or replace as needed. See "IV.C. Water Regulating Valve Adjustment (water-cooled models)."
- h) **Freeze Termination Diagnosis:** After 5 min. in freeze, disconnect CB K5 FS connector. 15 sec. later appliance should switch out of the freeze cycle (15 second delay after FS opens before terminating the freeze cycle). If appliance remains in freeze longer than 15 sec. after FS removed, replace CB. If appliance switches with FS removed but would previously not switch out of freeze with FS connected (long freeze - 3 beep alarm), see "II.E. Float Switch Check and Cleaning."

Note: Normal freeze cycle will last 20 to 40 min. depending on model and conditions. Cycle times and pressures should follow performance data provided in this manual. See "VIII.B. Performance Data."

- i) **Short Freeze Cycle Diagnosis:** Confirm water tank fills and overflows during 1 min. fill and harvest cycles. If not, check water supply filters, shut-off valve, WV screen. If water tank empties before 5 min. timer terminates and freeze cycle is short, check that CV is not leaking by (water flowing down the potable drain). If CV is leaking by, remove and clean CV, replace rubber seat and spring if necessary. If water tank is full, see "II.E. Float Switch Check and Cleaning." for erratic operating FS.

7) **Pump-Out Cycle – LEDs 1, 3, and 2 are on (10/20 second pump-out).** Timing of the first pump-out is determined by S4 dip switch 5 & 6. See the table below.

"G" Control Board Settings			
S4 Dip Switch Setting		Pump-Out Frequency	"G" Control Board
No. 5	No. 6		
OFF	OFF	Every cycle	After 2nd freeze cycle
ON	OFF	Every 2 cycles	After 3rd freeze cycle
OFF	ON	Every 5 cycles	After 6th freeze cycle
ON	ON	Every 10 cycles	After 11th freeze cycle

Comp and FMR continue, HGV energizes. If S4 dip switch 3 & 4 are set to 3 off and 4 on, LED 4 turns on and WV and X11 relay energize, energizing X10 relay. **NOTICE! S4 dip switch 3 & 4 must not be set to 3 off and 4 on. Otherwise, PM will rotate in freeze cycle direction instead of pump-out direction.** FM and LLV de-energize. PM stops for 2 sec., then reverses for 10/20 sec. depending on pump-out timer (S4 dip switch 3 & 4) setting. When the pump-out timer terminates, pump-out

is complete. The pump-out frequency control (S4 dip switch 5 & 6) is factory set, and generally no adjustment is required. However, the pump-out frequency control can be set to have a pump-out occur every cycle, or every 2, 5, or 10 cycles. For details, see "III.C.4. Pump-Out Frequency Control (S4 dip switch 5 & 6)."

**Pump-Out Diagnosis:** In the freeze cycle before pump-out (see table above), after 5 min. of freeze disconnect CB black K5 connector (FS connector). Check that PM stops and re-starts and that PM rotation is correct (water flowing down the drain through CV). If PM does not stop and re-start, check that CB LEDs 1, 3, and 2 are on. If not, replace CB. If LEDs 1, 3, and 2 are on and PM does not energize, check for 115VAC at CB K1 #5 (DBU) to neutral (W). If 115VAC is not present, replace CB. If 115VAC is present, check that X10 relay is de-energized. If not, check X11 relay status. If X11 relay is energized, replace CB. If X11 relay is de-energized and X10 relay is energized, replace X11 relay (contacts sticking). If X10 relay is de-energized, check for 115VAC at terminal #6 (DBU) to neutral (W) and terminal #2 (DBU) to neutral (W). If 115VAC is present on terminal #6 (DBU) and not on terminal #2 (DBU), replace X10 relay. If PM is energized and rotating in pump-out rotation, make sure the drain line is not clogged and that CV is clean and operating properly.

Confirm FM and LLV de-energize. If FM or LLV are energized with LEDs 1, 3, and 2 on, replace CB.

8) **Normal Harvest Cycle** – Same as the initial harvest cycle. Return to step 5a) above.

Note: Appliance continues to cycle until MBC is satisfied or power is switched off. The appliance always restarts at the 1-min. fill cycle.

9) **Shutdown**

**Mechanical Bin Control:**

See "II.D.2. Mechanical Bin Control Check."

Legend: **BC**–bin control; **CB**–control board; **Comp**–compressor; **CV**–check valve; **FM**–fan motor; **FMR**–fan motor remote; **FS**–float switch; **HGV**–hot gas valve; **HM**–headmaster (C.P.R.); **HPS**–high-pressure switch; **LLV**–liquid line valve; **MBC**–mechanical bin control; **PM**–pump motor; **TXV**–thermostatic expansion valve; **WRV**–water regulating Valve; **WV**–inlet water valve

## C. Control Board Check

Before replacing CB that does not show a visible defect and that you suspect is bad, always conduct the following check procedure. This procedure will help you verify your diagnosis.

Alarm Reset: If CB is in alarm (beeping), press the "ALARM RESET" button on CB while CB is beeping. **WARNING! Risk of electric shock. Care should be taken not to touch live terminals.** Once reset, the icemaker starts at the 1-minute fill cycle. For audible alarm information, see "III.B. LED Lights and Audible Alarm Safeties."

- 1) Check the dip switch settings to assure that S4 dip switch 3, 4, 7, 8, 9, 10 and S5 dip switch 1 through 5 ("G" CB) are in the factory default position. S4 dip switch 1, 2, 5, 6 are cleaning adjustments and the settings are flexible. For factory default settings, see "III.C.1. Default Dip Switch Settings."
- 2) Move the control switch to the "ICE" position. If the red "POWER OK" LED is on, control voltage is good, continue to step 3. If the "POWER OK" LED is off, check CT secondary circuit. CT output is 10.5VAC at 115VAC primary input. If the secondary circuit has proper voltage and the red LED is off, replace CB.

If the secondary circuit does not have proper voltage, check CT primary circuit. Check for 115VAC at CB K1 connector pin #10 (BR) to neutral (W) for 115VAC. Always choose a white (W) neutral wire to establish a good neutral connection when checking voltages. For additional checks, see "II.G.1. No Ice Production."

- 3) The "OUTPUT TEST" button provides a relay sequence test. Make sure the control switch is in the "ICE" position, then press the "OUTPUT TEST" button. For the correct lighting sequence, see the table below. Note that the order of the LEDs from the outer edge of the control board is 1, 4, 3, 2. Components (e.g., compressor) cycle during the test.

Control Board	Correct LED Lighting Sequence
"E"	2, 3, 4, 1
"G"	1, 4, 3, 2

Following the test, the icemaker begins operation at the 1-minute fill cycle for both "E" and "G" control boards. If the LEDs do not light as described above, replace CB.

- 4) To verify voltage output from CB to the components, slide the CB K1 connector out far enough to allow multimeter lead contact. With the icemaker in the cycle to be tested, check output voltage from the corresponding pin on CB K1 connector to a neutral (W wire). If output voltage is not found and the appropriate LED is on, replace CB.

Legend: **CB**—control board; **CT**—control transformer

## D. Bin Control Check

### 1. Thermostatic Bin Control Check

TBC shuts down the icemaker within 10 sec. when ice contacts the thermostatic bulb, regardless of the cycle at activation.

#### **NOTICE**

When the ambient temperature is below 45°F (7°C), TBC opens and shuts down the appliance even if the ice storage bin is empty. When BC is set in the prohibited range, the appliance operates continuously even if the ice storage bin is filled with ice. Setting in the prohibited range may result in severe damage to the appliance.

TBC is factory set, and generally no adjustment is required. However, adjustment may be needed in some conditions, particularly at higher altitude locations.

Note: On "G" control boards, a jumper (4A4883G01) must be placed on CB red K4 connector. Otherwise, CB yellow "BC OPEN" LED is on and appliance will not start.

To check TBC, follow the steps below.

- 1) Turn off the power supply.
- 2) Remove the front panel, then move the control switch to the "OFF" position.
- 3) Remove the control box cover, then clear any ice away from TBC bulb.
- 4) Disconnect TBC wires from TBC switch.
- 5) Hold your hand around the bulb to warm it up.
- 6) Check for continuity across TBC switch. If closed, continue to step 6. If open, adjust or replace TBC.
- 7) With the multimeter test leads still in place, hold ice on TBC bulb to lower the temperature. Within 10 sec., TBC switch should open. If it remains closed, adjust or replace TBC.

Legend: **TBC**—thermostatic bin control

## 2. Mechanical Bin Control Check and Cleaning

### a) Mechanical Bin Control Check

This appliance uses a lever-actuated proximity switch to control the ice level in the storage bin. No adjustment is required.

To check MBC, follow the steps below.

- 1) Turn off the power supply.
- 2) Remove the front panel, then move the control switch to the "OFF" position.
- 3) Remove the control box cover, then clear any ice away from MBC.
- 4) Check MBC wire harness connections. See Fig. 1.
- 5) Disconnect MBC connector from CB K4 connector.
- 6) Check for continuity across the wires of MBC connector. When the actuator paddle is not engaged, MBC switch is closed. If open, check that the wire harness connector is properly connected and that the actuator paddle is not sticking. Clean if necessary. See "II.D.2.b) Mechanical Bin Control Cleaning." If MBC switch still reads open, replace MBC.
- 7) Press and hold the actuator paddle; check for continuity across the wires of MBC connector. When the actuator paddle is engaged, MBC switch is open. If closed, check that the actuator paddle is not restricted. Clean if necessary. See "II.D.2.b) Mechanical Bin Control Cleaning." If MBC switch still reads closed, replace MBC.
- 8) Reconnect MBC connector to CB K4 connector, then move the control switch to the "ICE" position. Turn on the power supply.
- 9) Check that CB green "BC CLOSED" LED is on.
- 10) Allow the icemaker to cycle on. Press and hold the actuator paddle. CB yellow "BC OPEN" LED should turn on and the icemaker should shut down according to the chart below. If it does not, replace CB.

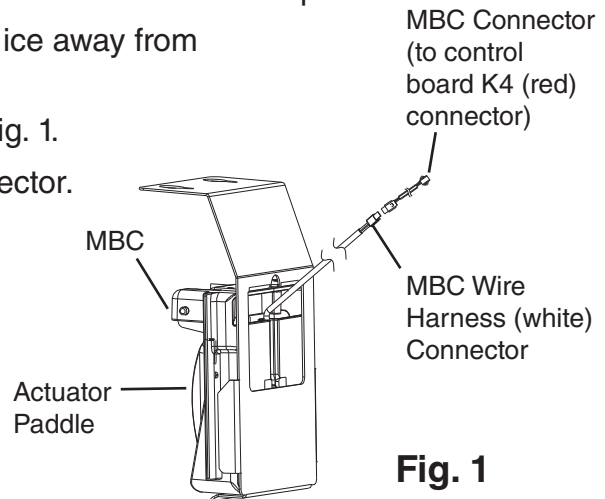

**Fig. 1**

**Model Shown: KM-901M\_H/3**

Cycle at Mechanical Bin Control Activation	Shutdown
Fill Cycle	15 sec. after activation.
Harvest Cycle	At the end of the harvest cycle, or up to 15 sec. into the freeze cycle if activated at the end of the harvest cycle.
Freeze Cycle	15 sec. after activation if activated at least 15 sec. before the 5-min. short cycle protection timer terminates. Otherwise, at the end of the next harvest cycle.

Legend: **MBC**—mechanical bin control; **CB**—control board

### b) Mechanical Bin Control Cleaning

Scale may build up on MBC. Scale can cause the actuator paddle and magnet to stick. In this case, MBC should be cleaned.

#### **⚠ WARNING**

**CHOKING HAZARD:** Ensure all components, fasteners, and thumbscrews are securely in place after the icemaker is serviced. Make sure that none have fallen into the dispense unit/ice storage bin.

- 1) Turn off the power supply.
- 2) Remove the front panel, then move the control switch to the "OFF" position.
- 3) Clear any ice away from MBC.
- 4) Disconnect MBC connector from CB K4 connector, then remove MBC from the icemaker.
- 5) Remove the actuator paddle from the switch mount. See Fig. 2.
- 6) Wipe down MBC with a mixture of 1 part of Hoshizaki "Scale Away" and 25 parts of warm water. Rinse the parts thoroughly with clean water.
- 7) Reassemble MBC and replace it in its correct position.  
Note: If the magnet was removed for cleaning, be sure to replace it in its correct position.
- 8) Reconnect MBC connector to CB K4 connector, then move the control switch to the "ICE" position.
- 9) Replace the control box cover in its correct position.
- 10) Turn on the power supply to start the automatic icemaking process.
- 11) Replace the front panel in its correct position.

Legend: **MBC**—mechanical bin control

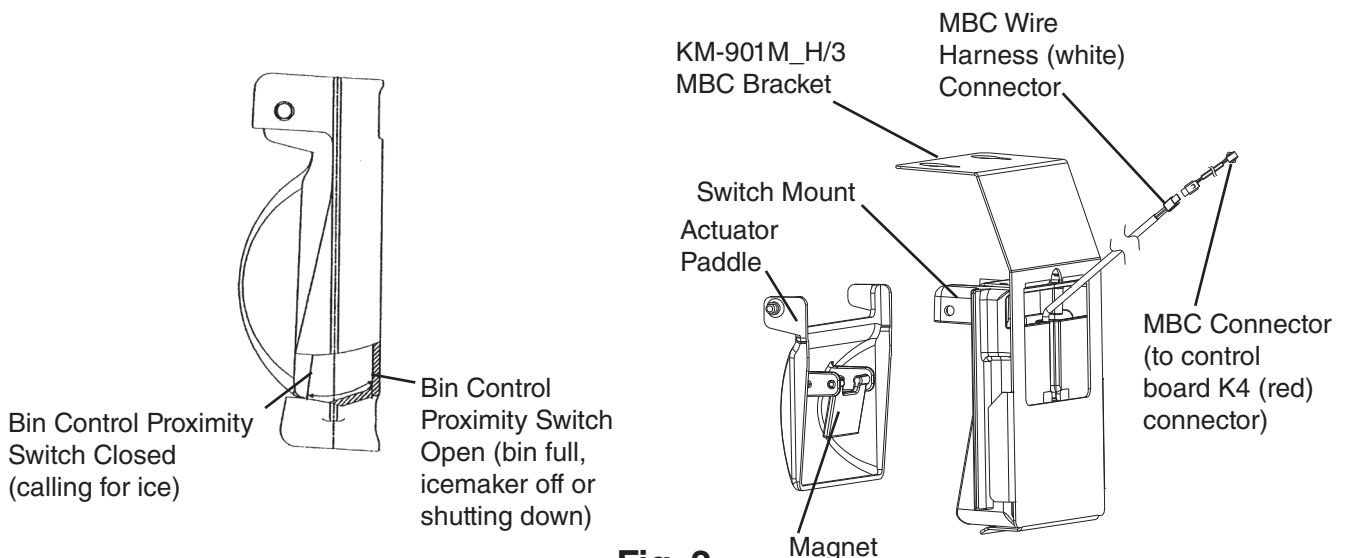

**Fig. 2**

Model Shown: KM-901M\_H/3

## E. Float Switch Check and Cleaning

FS is used to determine that there is sufficient water in the water tank after the 1-min. fill cycle and after each harvest cycle. FS is also used to determine that the appropriate volume of water has been converted into ice before switching out of the freeze cycle. No adjustment is required.

### 1. Float Switch Check

To check FS, follow the steps below.

- 1) Turn off the power supply.
- 2) Remove the front panel, then move the control switch to the "OFF" position.
- 3) Drain the water tank.
  - a) On KM-320M\_H, KM-515M\_H, KM-600M\_H, KM-650M\_H, and KM-901M\_H, remove the base cover, then disconnect one end of the pump tubing to drain the water tank. See Fig. 3. After the water tank has drained, reconnect the pump tubing.
  - b) On KM-1340M\_H and KM-1601M\_H, remove the rubber cap covering the overflow pipe in the water tank. Remove the overflow pipe by turning it counterclockwise. After the water tank has drained, replace the overflow pipe and the rubber cap in their correct positions. Note: Be sure the overflow pipe o-ring is in its correct position on the overflow pipe.
- 4) Remove the control box cover.
- 5) Disconnect FS connector from CB K5 connector.
- 6) Check for continuity across FS leads. With the water tank empty, FS should be open. If open, continue to step 7. If closed, follow the steps in "II.E.2. Float Switch Cleaning." After cleaning FS, check it again. Replace if necessary.
- 7) Reconnect FS connector to CB K5 connector, then replace the control box cover in its correct position.
- 8) Move the control switch to the "ICE" position. Replace the front panel in its correct position, then turn on the power supply. After 1 min., the 1-min. fill cycle should end and the initial harvest cycle should begin. If the initial harvest cycle begins, FS is good and the check is complete. If the initial harvest cycle does not begin, continue to step 9.
- 9) Turn off the power supply.
- 10) Remove the front panel. Move the control switch to the "OFF" position.
- 11) Remove the control box cover.
- 12) Disconnect FS connector from CB K5 connector.

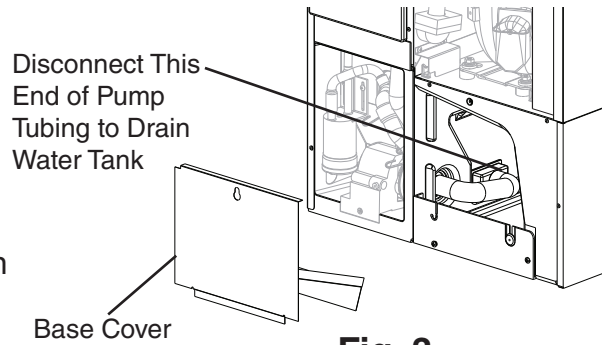

**Fig. 3**

- 13) Check for continuity across FS leads. With the water tank full, FS should be closed. If FS is closed and the icemaker will not switch from the 1-min. fill cycle to the initial harvest cycle, replace CB.

If FS is open, confirm that the water tank is full. If the water tank is not full, check the water supply, water filters, and inlet water valve. If the water tank is full, follow the steps in "II.E.2. Float Switch Cleaning." After cleaning FS, check it again. Replace if necessary.

Legend: **CB**—control board; **FS**—float switch

## 2. Float Switch Cleaning

Depending on local water conditions, scale may build up on FS. Scale on the switch can cause the float to stick. In this case, FS should be cleaned.

- 1) Turn off the power supply.
- 2) Remove the front panel, then move the control switch to the "OFF" position.
- 3) Drain the water tank.
  - a) On KM-320M\_H, KM-515M\_H, KM-600M\_H, KM-650M\_H, and KM-901M\_H, remove the base cover, then disconnect one end of the pump tubing to drain the water tank. See Fig. 3. After the water tank has drained, reconnect the pump tubing.
  - b) On KM-1340M\_H and KM-1601M\_H, remove the rubber cap covering the overflow pipe in the water tank. Remove the overflow pipe by turning it counterclockwise. After the water tank has drained, replace the overflow pipe and the rubber cap in their correct positions. Note: Be sure the overflow pipe o-ring is in its correct position on the overflow pipe.
- 4) Disconnect the vent tube and the flush tube from the top of FS, then remove FS assembly and remove the rubber boot from the bottom of FS assembly. See Fig. 4.
- 5) Remove the retainer rod from the bottom of FS housing, then remove the float. Be careful not to bend the retainer rod excessively when removing it.
- 6) Wipe down FS housing, shaft, float, and retainer rod with a mixture of 1 part Hoshizaki "Scale Away" and 25 parts warm water. Clean the inside of the rubber boot and hose with cleaning solution. Rinse the parts thoroughly with clean water.
- 7) Reassemble FS assembly and replace it and the rubber boot in their correct positions. Reconnect the vent tube and the flush tube.
- 8) Move the control switch to the "ICE" position.
- 9) Replace the base cover (if applicable) and front panel in their correct positions.
- 10) Turn on the power supply to start the automatic icemaking process.

Legend: **CB**—control board; **FS**—float switch

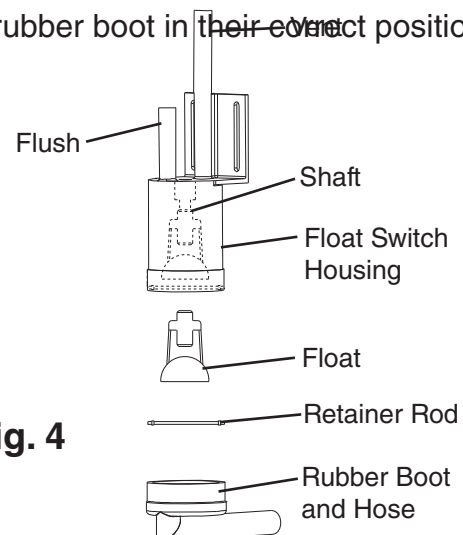

**Fig. 4**

## F. Thermistor Check

To check thermistor resistance, follow the steps below.

- 1) Turn off the power supply.
- 2) Remove the front panel. Move the control switch to the "OFF" position.
- 3) Remove the control box cover.
- 4) Remove the thermistor from the refrigerant tubing.
- 5) Immerse the thermistor sensor portion in a glass containing ice and water for 2 or 3 min.
- 6) Disconnect the thermistor connector from CB K3 connector and check the resistance between thermistor leads. Normal range is 4.7 to 6.2 k $\Omega$ . If outside the normal range, replace the thermistor. See "IV.B. Component Service Information." If within the normal range, continue to the next step.
- 7) Replace the thermistor in its correct position. See "IV.B. Component Service Information."
- 8) Reconnect the thermistor connector to CB K3 connector.
- 9) Replace the control box cover in its correct position.
- 10) Move the control switch to the "ICE" position.
- 11) Replace the front panel in its correct position.
- 12) Turn on the power supply.
- 13) Once the harvest cycle starts (Comp energizes), begin timing the harvest cycle.
- 14) The harvest timer and harvest cycle should terminate within 2 to 5 min. If the harvest cycle does not terminate within 2 to 5 min., replace CB.

Legend: **CB**—control board; **Comp**—compressor

## G. Diagnostic Tables

### 1. No Ice Production

No Ice Production - Possible Cause	
1. Power Supply	a) Off, blown fuse, or tripped breaker.
	b) Not within specifications.
2. Main Transformer (208-230/60/1 Models with main transformer and all 208-230/60/3 Models)	a) Voltage tap switch not set to proper voltage.
	b) Coil winding open or shorted.
3. Fuse (Control Box)	a) Blown.
4. Thermostatic Bin Control See "II.D. Bin Control Check"	a) Tripped with bin filled with ice.
	b) Ambient temperature too cool.
	c) Set too warm.
	d) Bulb out of position.
	e) Open contacts, defective.
5. Control Switch	a) In "OFF" or "WASH" position.
	b) Bad contacts.
6. High-Pressure Switch	a) Dirty condenser.
	b) Fan motor not operating.
	c) Refrigerant overcharged.
	d) Bad contacts.
	e) Refrigerant lines or components plugged.
7. Control Transformer (115VAC/10.5VAC)	a) Coil winding open or shorted.
8. Control Board See "II.C. Control Board Check"	a) In alarm.
	b) Yellow "BC OPEN" LED on (bin full) ("G" control board).
	c) Defective.
9. Mechanical Bin Control See "II.D. Bin Control Check"	a) Tripped with bin filled with ice.
	b) Actuator does not move freely.
	c) Defective.
10. Water Supply	a) Water supply off or improper water pressure.
	b) External water filters clogged.
11. Inlet Water Valve	a) Screen or orifice clogged.
	b) Coil winding open.
	c) Water valve open in freeze cycle.
12. Float Switch See "II.E. Float Switch Check and Cleaning"	a) Float does not move freely.
	b) Defective.
13. Compressor	a) Compressor relay/magnetic contactor contacts bad or coil winding open.
	b) Start capacitor or run capacitor defective (single phase).
	c) Internal protector open.
	d) Start relay contacts bad or coil winding open (single phase).
	e) Compressor defective.

<b>No Ice Production - Possible Cause</b>	
14. Hot Gas Valve	a) Closed in harvest cycle.
	b) Open in freeze cycle.
15. Thermistor See "II.F. Thermistor Check"	a) Loose, disconnected, or defective.
16. Pump Motor	a) Motor winding open.
	b) Bearing worn out or locked rotor.
	c) Defective capacitor.
	d) Mechanical seal worn out.
17. Thermostatic Expansion Valve	a) Bulb loose.
	b) Operating erratically.
18. Liquid Line Valve	a) Closed in freeze cycle.
	b) Open in harvest cycle.
19. Fan Motor	a) Motor winding open.
	b) Bearing worn out or locked rotor.
	c) Defective capacitor.
20. Water System	a) Water leaks causing short freeze time.

## 2. Freeze-Up

Defrost and clean the icemaker prior to diagnosing freeze-up. Fill out a freeze-up checklist. See the Hoshizaki America Technician's Pocket Guide or contact your local distributor for a copy of the freeze-up checklist.

<b>Freeze-Up - Possible Cause</b>	
<b>Harvest Cycle</b>	
1. Evaporator	a) Scaled up.
	b) Damaged.
2. Cube Guides	a) Out of position.
	b) Damaged.
3. Spray Tubes and/or Spray Guides	a) Dirty.
	b) Out of position.
4. Water Supply	a) Low water pressure.
	b) External water filters clogged.
	c) Insufficient water line size. Minimum 1/4" Nominal ID (6 mm Nominal OD in the EU) copper water tubing or equivalent.
5. Inlet Water Valve	a) Screen or orifice clogged.
	b) Defective.
6. Float Switch See "II.E. Float Switch Check and Cleaning"	a) Dirty, sticking.
	b) Defective.
7. Refrigerant Charge	a) Low.
8. Control Board See "III.C. Settings and Adjustments" and "II.C. Control Board Check"	a) Harvest timer (S4 dip switch 1 & 2) set too short.
	b) Harvest pump timer (S4 dip switch 7) not in factory default position ("G" control board).
	c) Defective.

<b>Freeze-Up - Possible Cause</b>	
9. Bin Control See "II.D. Bin Control Check"	a) Actuator does not move freely.
10. Thermistor See "II.F. Thermistor Check"	a) Loose, disconnected, or defective.
11. Thermostatic Expansion Valve	a) Defective.
12. Hot Gas Valve	a) Closed or restricted.
13. Liquid Line Valve	a) Open.
<b>Freeze Cycle</b>	
1. Evaporator	a) Scaled up.
	b) Damaged.
2. Spray Tubes and/or Spray Guides	a) Dirty.
	b) Out of position.
3. Refrigerant Charge	a) Low.
4. Control Board See "II.C. Control Board Check"	a) Freeze timer (S4 dip switch 9 & 10) set incorrectly.
	b) Defective.
5. Inlet Water Valve	a) Leaking by.
6. Float Switch See "II.E. Float Switch Check and Cleaning"	a) Float does not move freely.
	b) Defective.
7. Pump Motor	a) RPM too slow.
	b) Impeller damaged.
8. Thermostatic Expansion Valve	a) Bulb loose or defective.
9. Liquid Line Valve	a) Restricted.
10. Headmaster (C.P.R.) (remote models)	a) Not bypassing.

### 3. Low Ice Production

<b>Low Ice Production - Possible Cause</b>	
<b>Long Harvest Cycle</b>	
1. Evaporator	a) Scaled up.
2. Spray Tubes and/or Spray Guides	a) Dirty.
	b) Out of position.
3. Refrigerant Charge	a) Low.
4. Water Supply	a) Low water pressure.
	b) External water filters clogged.
	c) Insufficient water line size. Minimum 1/4" Nominal ID (6 mm Nominal OD in the EU) water tubing or equivalent.
	d) Too cold.
5. Control Board See "II.C. Control Board Check"	a) Thermistor connection loose (K3).
	b) Defective.
6. Thermistor See "II.F. Thermistor Check"	a) Loose, disconnected, or defective.
7. Hot Gas Valve	a) Erratic or closed.

<b>Low Ice Production - Possible Cause</b>	
8. Inlet Water Valve	a) Screen or orifice clogged.
9. Compressor	a) Inefficient or off.
10. Liquid Line Valve	a) Erratic or open.
11. Thermostatic Expansion Valve	a) Defective.
<b>Long Freeze Cycle</b>	
1. Evaporator	a) Scaled up, dirty.
2. Float Switch See "II.E. Float Switch Check and Cleaning"	a) Scaled up, dirty.
	b) Float sticking.
	c) Defective switch.
3. Inlet Water Valve	a) Leaking by.
4. Hot Gas Valve	a) Erratic or open.
5. Condenser	a) Clogged.
6. Control Board See "II.C. Control Board Check"	a) Float switch connection loose (K5).
	b) Defective.
7. Refrigerant Charge	a) Low.
8. Thermostatic Expansion Valve	a) Bulb loose.
	b) Defective.
9. Compressor	a) Inefficient or off.
10. Pump Motor	a) RPM too slow.
11. Liquid Line Valve	a) Erratic or restricted.
12. Headmaster (C.P.R.) (remote models)	a) Not bypassing.

---

### III. Controls and Adjustments

- A Hoshizaki exclusive control board is employed in KM series appliances.
- All models are pretested and factory adjusted.
- For a control board check procedure, see "II.C. Control Board Check."

<b><i>NOTICE</i></b>
<ul style="list-style-type: none"><li>• Fragile, handle very carefully.</li><li>• The control board contains integrated circuits, which are susceptible to failure due to static discharge. It is especially important to touch the metal part of the icemaker when handling or replacing the control board.</li><li>• Do not touch the electronic devices on the control board or the back of the control board.</li><li>• Do not change wiring and connections. Do not misconnect K3 WHITE, K4 RED, and K5 BLACK, because the same connector is used for the thermistor, mechanical bin control, and float switch. K4 RED is not used on "E" control board models.</li><li>• Do not short out power supply to test for voltage.</li><li>• Always replace the whole control board assembly if it goes bad.</li></ul>

# A. Control Board Layout

## 1. "E" Control Board

### "E" Control Board

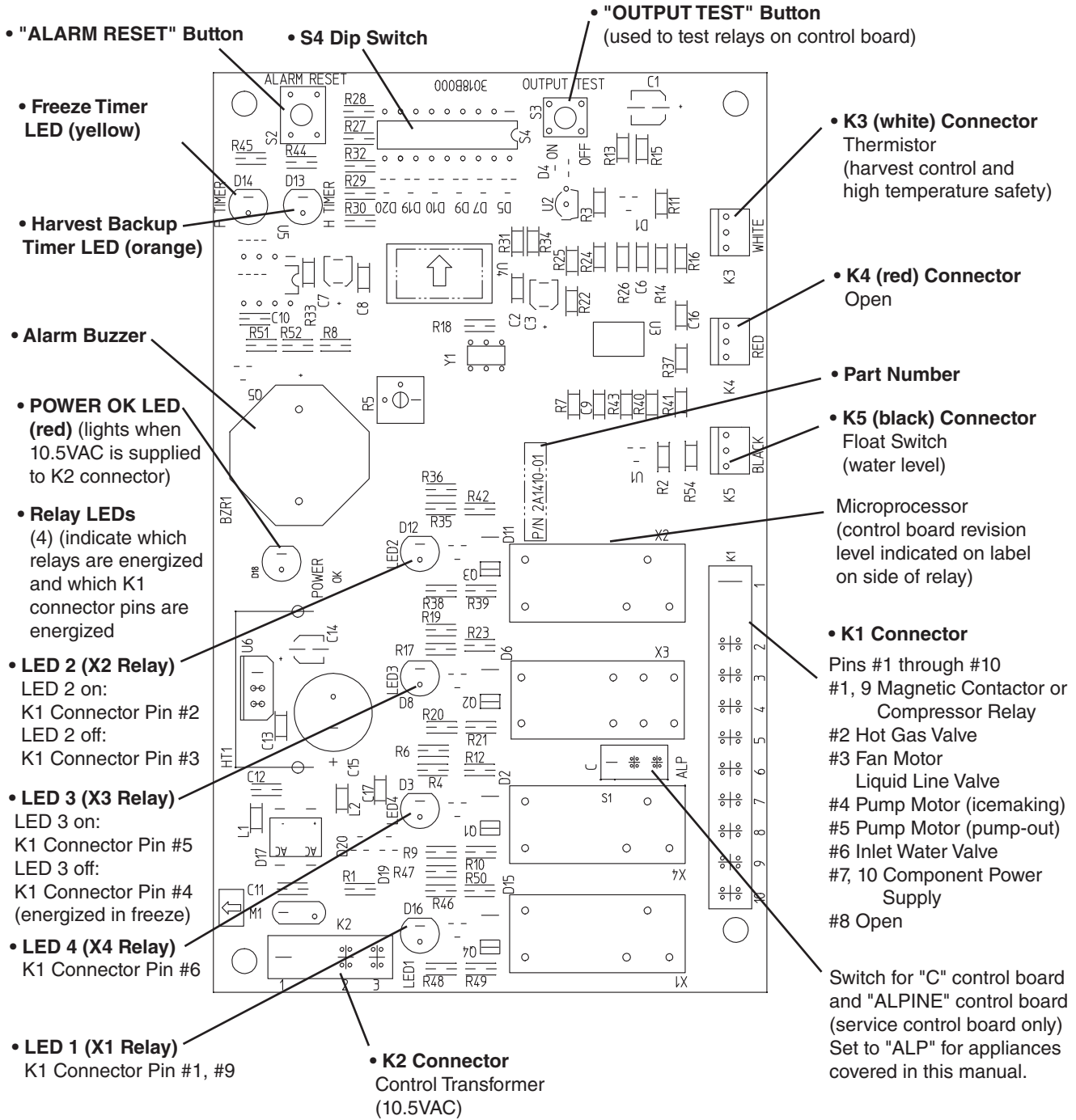

<b>"E" Control Board</b>	
Part Number	<b>2A1410-02</b>

## 2. "G" Control Board

### "G" Control Board

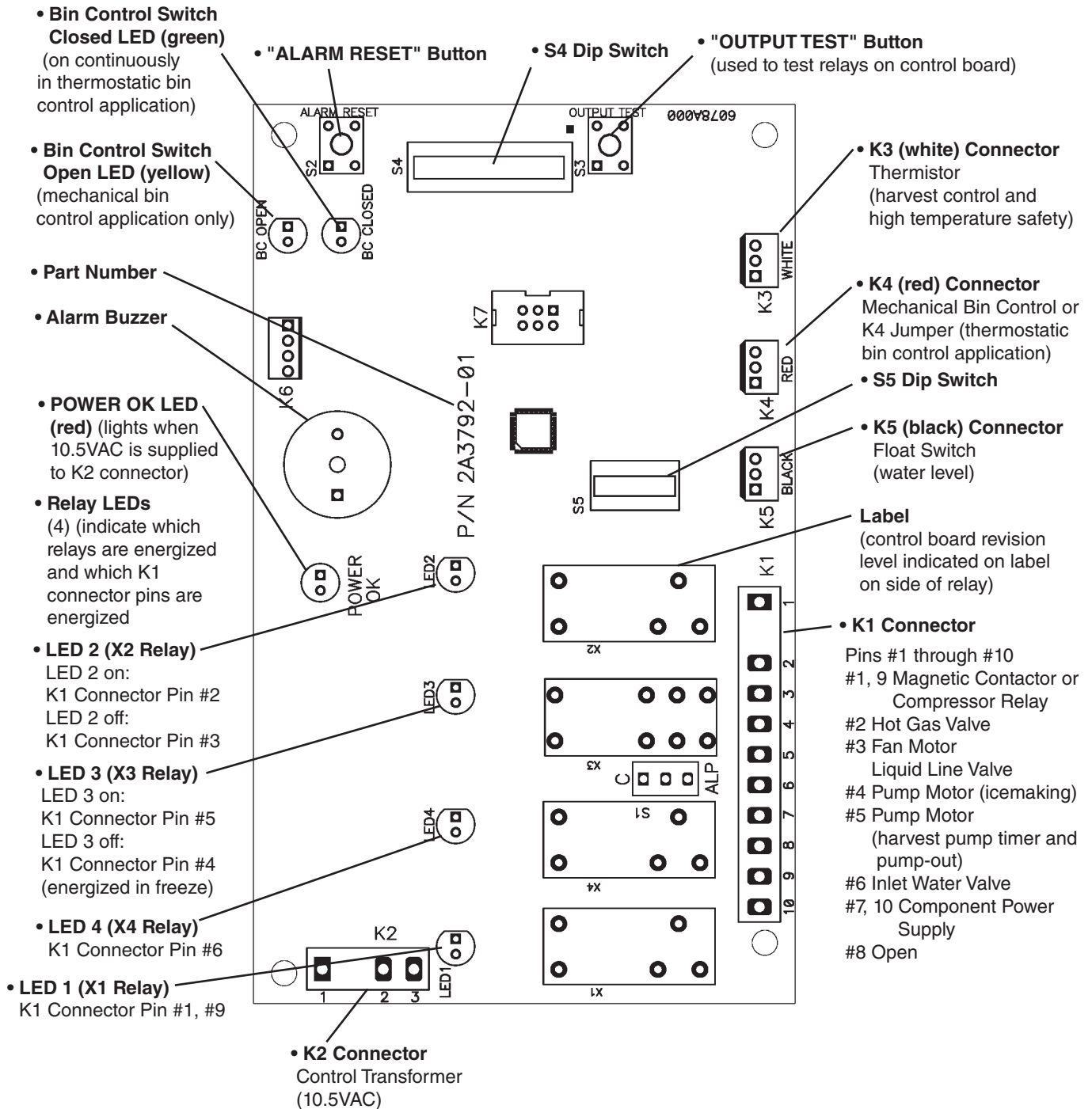

"G" Control Board	
Part Number	2A3792-01

## B. LED Lights and Audible Alarm Safeties

### 1. "E" Control Board

At startup, a 5-second delay occurs while the control board conducts an internal timer check. A beep occurs when power is turned off. The red "POWER OK" LED indicates proper control voltage and remains on unless a control voltage problem occurs. The green LEDs 1 through 4 energize and sequence from initial startup as listed in the table below. Note that the order of the LEDs from the outer edge of the control board is 1, 4, 3, 2.

Sequence Step	LED	Energized Components	Time LEDs are On		
			Min.	Max.	Avg.
1-Minute Fill Cycle	4	WV			1 minute
Harvest Cycle	1, 4, 2	Comp, FMR, HGV, WV	2 minutes	20 minutes	3 to 5 minutes
Freeze Cycle	1	Comp, FM/FMR, PM, LLV	5 minutes	freeze timer setting	30 to 35 minutes
Pump-Out Cycle	1, 4*, 3, 2	Comp, FMR, HGV, PM, WV*	10 seconds	20 seconds	*pump-out timer setting

The built in safeties shut down the icemaker and have alarms as listed below.

No. of Beeps (every 3 sec.)	Type of Alarm	Notes
1	High Evaporator Temp. (temperature > 127°F) (53°C)	Check for harvest problem (stuck HGV or relay), hot water entering icemaker, or shorted thermistor.
2	Harvest Backup Timer (harvest > 20 min. for two cycles in a row)	Orange "H TIMER" LED on. Check for open thermistor, HGV not opening, TXV or LLV leaking by, low charge, or inefficient Comp, or WRV leaking by.
3	Freeze Timer (freeze > specified setting for two cycles in a row)	Yellow "F TIMER" LED on. Check for FS stuck closed (up), WV leaking by, HGV leaking by, PM not pumping, TXV not feeding properly, LLV not opening, low charge, HM not bypassing, or inefficient Comp.
To reset the above safeties, press the "ALARM RESET" button with the power supply on.		
6	Low Voltage (92Vac±5% or less)	Red LED turns off if voltage protection operates. The control voltage safeties automatically reset when voltage is corrected.
7	High Voltage (147Vac±5% or more)	

Legend: **Comp**—compressor; **FM**—fan motor; **FMR**—fan motor remote; **FS**—float switch; **HGV**—hot gas valve; **HM**—headmaster (C.P.R.); **LLV**—liquid line valve; **PM**—pump motor; **TXV**—thermostatic expansion valve; **WRV**—water regulating valve; **WV**—inlet water valve

## 2. "G" Control Board

At startup, a 5-second delay occurs while the control board conducts an internal timer check. A beep occurs when the control switch is moved to the "ICE" position. The red "POWER OK" LED indicates proper control voltage and remains on unless a control voltage problem occurs. The green LEDs 1 through 4 energize and sequence from initial startup as listed in the table below. Note that the order of the LEDs from the outer edge of the control board is 1, 4, 3, 2.

Sequence Step	LED	Energized Components	Time LEDs are On		
			Min.	Max.	Avg.
1-Minute Fill Cycle	4	WV			1 minute
Harvest Cycle	1, 4, 2	Comp, FMR, HGV, WV	2 minutes	20 minutes	3 to 5 minutes
Harvest Pump Timer	1, 3, 2	Comp, FMR, HGV, PM	0 seconds	50 seconds	harvest pump timer setting
Freeze Cycle	1	Comp, FM/FMR, PM, LLV	5 minutes	freeze timer setting	30 to 35 minutes
Pump-Out Cycle	1, 4*, 3, 2	Comp, FMR, HGV, PM, WV*	10 seconds	20 seconds	*pump-out timer setting

The built-in safeties shut down the icemaker and have alarms as listed below.

No. of Beeps (every 3 sec.)	Type of Alarm	Notes
1	High Evaporator Temp. (temperature > 127°F) (53°C)	Check for harvest problem (stuck HGV or relay), hot water entering icemaker, or shorted thermistor.
2	Harvest Backup Timer (harvest > 20 min. for two cycles in a row)	Check for open thermistor, HGV not opening, TXV or LLV leaking by, low charge, or inefficient Comp, or WRV leaking by.
3	Freeze Timer (freeze > freeze timer setting for two cycles in a row)	Check for FS stuck closed (up), WV leaking by, HGV leaking by, PM not pumping, TXV not feeding properly, LLV not opening, low charge, HM not bypassing, or inefficient Comp.
To reset the above safeties, press the "ALARM RESET" button with the power supply on.		
6	Low Voltage (92Vac±5% or less)	Red LED turns off if voltage protection operates. The control voltage safeties automatically reset when voltage is corrected.
7	High Voltage (147Vac±5% or more)	

Legend: **Comp**—compressor; **FM**—fan motor; **FMR**—fan motor remote; **FS**—float switch; **HGV**—hot gas valve; **HM**—headmaster (C.P.R.); **LLV**—liquid line valve; **PM**—pump motor; **TXV**—thermostatic expansion valve; **WRV**—water regulating valve; **WV**—inlet water valve

## C. Settings and Adjustments

### NOTICE

Dip switches are factory set. Failure to maintain factory settings may adversely affect performance and warranty coverage. For more information, contact your Hoshizaki Service Center.

#### 1. Default Dip Switch Settings

The dip switches are factory-adjusted to the following positions for both the "E" and "G" control boards:

##### a) "E" and "G" Control Board without Harvest Pump Timer Operation

"E" Control Board S4 Dip Switch No.	1	2	3	4	5	6	7	8	9	10
KM-320MAH, KM-320MWH	OFF	OFF	OFF	ON	ON	ON	OFF	OFF	OFF	OFF
KM-515MAH, KM-515MWH, KM-515MRH	OFF	OFF	OFF	OFF	OFF	OFF	OFF	OFF	ON	OFF
KM-600MAH, KM-650MAH, KM-650MWH	OFF	OFF	OFF	OFF	ON	ON	OFF	OFF	OFF	OFF
KM-650MRH	OFF	OFF	OFF	OFF	ON	ON	OFF	OFF	ON	OFF
KM-901MAH, KM-901MWH, KM-901MRH/3	ON	OFF	ON	OFF	ON	ON	OFF	OFF	OFF	ON
KM-1100MAH, KM-1100MWH, KM-1100MRH	OFF	OFF	OFF	OFF	ON	ON	ON	OFF	OFF	OFF
KM-1340MAH	OFF	OFF	ON	ON	ON	ON	OFF	OFF	OFF	OFF
KM-1340MWH, KM-1601MRH/3	OFF	OFF	ON	OFF	ON	ON	OFF	OFF	OFF	ON
KM-1340MRH, KM-1340MRH3	OFF	OFF	ON	OFF	ON	ON	OFF	OFF	OFF	OFF

##### b) "G" Control Board with Harvest Pump Timer Operation

S4 Dip Switch No.	1	2	3	4	5	6	7	8	9	10
KM-340MAH, KM-340MWH	OFF	OFF	ON	OFF	ON	ON	ON	OFF	ON	OFF
KM-515MAH	OFF	OFF	OFF	OFF	ON	ON	ON	OFF	ON	OFF
KM-650MAH, KM-650MRH	ON	OFF	OFF	OFF	ON	ON	ON	OFF	OFF	OFF
KM-650MWH	OFF	OFF	OFF	OFF	ON	ON	ON	OFF	OFF	OFF
KM-901MAH	OFF	OFF	ON	OFF	ON	ON	ON	OFF	OFF	ON

S5 Dip Switch (Do Not Adjust) "G" Control Board					
Dip Switch No.	1	2	3	4	5
All Models	OFF	OFF	OFF	OFF	OFF

#### 2. Harvest Timer (S4 dip switch 1 & 2) S4 Dip Switch

##### "E" and "G" Control Boards

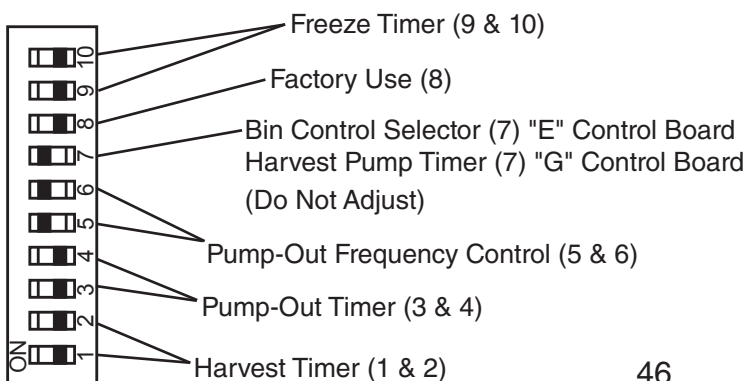

##### S5 Dip Switch "G" Control Board Only Do Not Adjust

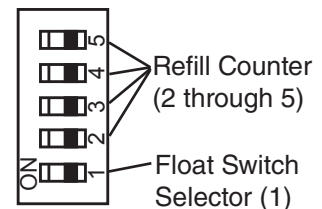

The harvest timer starts counting when the thermistor reaches 48°F (9°C) at the evaporator outlet and the control board reads 3.9 kΩ from the thermistor. The harvest timer is factory set, and generally no adjustment is required. However, a setting longer than the factory setting may be advised in cases where the drain provided at harvest needs to be prolonged for extra cleaning. Before changing this setting, contact Hoshizaki Technical Support at 1-800-233-1940 for recommendations. Keep in mind that setting the harvest timer to a longer setting decreases 24-hour production.

Note that the pump-out timer (S4 dip switch 3 & 4) acts in place of the harvest timer during cycles with a pump out. For details, see "III.C.3. Pump-Out Timer (S4 dip switch 3 & 4)."

Note: On models with a pump-out every cycle, the harvest timer is only relevant during the initial harvest cycle since a pump out occurs every cycle thereafter.

S4 Dip Switch Setting		Time (sec.)
No. 1	No. 2	
OFF	OFF	60
ON	OFF	90
OFF	ON	120
ON	ON	180

### 3. Pump-Out Timer (S4 dip switch 3 & 4)

<b>NOTICE</b>	
<ul style="list-style-type: none"> <li>• On KM-515M_H models without harvest pump timer operation, never adjust the pump-out timer's harvest timer (T2) for a time less than 150 sec. Otherwise, the icemaker will not perform properly.</li> <li>• On models with harvest pump timer, do not adjust 3 off and 4 on. Pump does not run in pump-out rotation in this setting.</li> </ul>	

When a pump-out is called for, the pump motor stops for 2 sec., then energizes in the reverse direction, taking water from the bottom of the water tank and forcing pressure against the check valve seat allowing water to go through the check valve and down the drain. At the same time, water flows through the small tube to power flush the float switch. The pump motor drains the water tank for the time determined by the pump-out timer. The pump-out timer also acts in place of the harvest timer during cycles with a pump-out. The pump-out timer is factory set, and generally no adjustment is required. However, where water quality is bad and the icemaker needs a longer pump-out time, the pump-out timer can be adjusted. The pump-out timer control can be set to pump-out for 10 or 20 sec.

S4 Dip Switch Setting		Time (sec.)		Inlet Water Valve
No. 3	No. 4	T1	T2	
OFF	OFF	10	150	Closed
ON	OFF	10	180	Closed
OFF	ON	10	120	Open
ON	ON	20	180	Closed

T1: Time to drain the water tank

T2: Harvest timer at pump out

#### 4. Pump-Out Frequency Control (S4 dip switch 5 & 6)

**NOTICE**

Do not adjust on KM-515M\_H without harvest pump timer. Adjustments to this setting on KM-515M\_H without harvest pump timer may adversely affect performance and warranty coverage.

The pump-out frequency control is factory set to drain the water tank every 10 cycles on all KM-320M\_H, KM-600MAH, KM-650M\_H, KM-901M\_H/3 and on KM-515MAH with harvest pump timer, and every cycle on KM-515M\_H without harvest pump timer. Generally no adjustment is required. However, where water quality is bad and the icemaker needs a pump-out more often, the pump-out frequency can be adjusted. The pump-out frequency control can be set to have a pump-out occur every cycle, or every 2, 5, or 10 cycles.

Timing of the first pump-out is dependent on the control board. On "E" control boards, the first pump-out is after the first freeze cycle. On "G" control boards, the first pump-out is dependent on S4 dip switch 5 & 6. See the table below.

"E" & "G" Control Board			1st Pump-Out	
S4 Dip Switch Setting		Pump-Out Frequency	"E" Control Board	"G" Control Board
No. 5	No. 6			
OFF	OFF	Every cycle	After 1st freeze cycle	After 2nd freeze cycle
ON	OFF	Every 2 cycles		After 3rd freeze cycle
OFF	ON	Every 5 cycles		After 6th freeze cycle
ON	ON	Every 10 cycles		After 11th freeze cycle

#### 5. Bin Control Selector or Harvest Pump Timer Operation (S4 dip switch 7)

Depending on the control board, S4 dip switch 7 is used for either bin control selection or harvest pump timer operation.

##### (1) Bin Control Selector, "E" Control Board

**NOTICE**

Do not adjust. This dip switch must be left in the factory default position or the icemaker will not operate correctly.

When set to on position on an icemaker with a thermostatic bin control, a 5-beep alarm sounds (open circuit) and the icemaker does not operate.

"E" Control Board	
S4 Dip Switch Setting	Bin Control
No. 7	
ON	Mechanical (requires resistor wire harness)
OFF	Thermostatic

(2) Harvest Pump Timer, "G" Control Board

<b>NOTICE</b>	
Factory set for proper operation. Do not adjust. Adjustment outside of the factory default setting may result in damage to the appliance.	

Depending on the harvest pump timer setting, the pump motor either stays off or is energized the last 50 seconds of harvest. When the pump motor is energized, water circulates over the evaporator. The harvest water valve is open during harvest for a maximum of 6 minutes or the length of harvest minus 0 or 50 seconds (determined by the harvest pump timer setting), whichever is shorter.

When S4 dip switch 7 is in the on position and harvest begins, X11 and X10 relays energize. A latching circuit is created through the X11 and X10 relays. For further details, see "VIII.C. Wiring Diagrams."

50 sec. before harvest termination, LED 4 turns off, inlet water valve and X11 relay de-energize. X10 relay remains energized through the latching circuit. Next, LED 3 turns on and control board K1 connector pin #5 (DBU wire) energizes, energizing the pump motor for the last 50 sec. of harvest.

<b>"G" Control Board</b>	
<b>S4 Dip Switch Setting</b>	<b>Pump Motor Time (sec.)</b>
<b>No. 7</b>	
ON	50
OFF	0

**6. Factory Use (S4 dip switch 8)**

Factory set for proper operation. Do not adjust. This must be left in the factory default position.

**7. Freeze Timer (S4 dip switch 9 & 10)**

<b>NOTICE</b>	
Adjust to proper specification, or the icemaker may not operate correctly.	

The freeze timer setting determines the maximum allowed freeze time to prevent possible freeze-up issues. Upon termination of the freeze timer, the control board initiates the harvest cycle or pump-out cycle. After 2 consecutive freeze timer terminations, the control board shuts down the icemaker. In this case, see "II.G.3. Low Ice Production" for possible solutions. The freeze timer is factory set and no adjustment is required. Before changing this setting, contact Hoshizaki Technical Support at 1-800-233-1940 for recommendations.

<b>S4 Dip Switch Setting</b>		<b>Time (min.)</b>
<b>No. 9</b>	<b>No. 10</b>	
OFF	OFF	60
OFF	ON	50
ON	OFF	70
ON	ON	75

### 8. Float Switch Selector (S5 dip switch 1): "G" Control Board

<b><i>NOTICE</i></b>
----------------------

Do not adjust. This must be left in the factory default position or the icemaker will not operate correctly.
--

### 9. Refill Counter (S5 dip switch 2 through 5): "G" Control Board

<b><i>NOTICE</i></b>
----------------------

Do not adjust. These must be left in the factory default position or the icemaker will not operate correctly.
---

### D. Control Switch

The control switch has three positions: "OFF" for power off, "ICE" for icemaking, and "WASH" to energize the pump motor when cleaning and sanitizing.

## IV. Refrigeration Circuit and Component Service Information

### WARNING

- This appliance should be diagnosed and repaired only by qualified service personnel to reduce the risk of death, electric shock, serious injury, or fire.
- Move the control switch to the "OFF" position and turn off the power supply. Place the disconnect in the "OFF" position. Lockout/Tagout to prevent the power supply from being turned back on inadvertently.
- **CHOKING HAZARD:** Ensure all components, fasteners, and thumbscrews are securely in place after the icemaker is serviced. Make sure that none have fallen into the dispenser unit/ice storage bin.
- Make sure all food zones in the icemaker and dispenser unit/ice storage bin are clean after service.

### A. Refrigeration Circuit Service Information

#### WARNING

- Repairs requiring the refrigeration circuit to be opened must be performed by properly trained and EPA-certified service personnel.
- Use an electronic leak detector or soap bubbles to check for leaks. Add a trace of refrigerant to the system (if using an electronic leak detector), and then raise the pressure using nitrogen gas (140 PSIG). Do not use R-404A as a mixture with pressurized air for leak testing.

#### NOTICE

- Always recover the refrigerant and store it in an approved container. Do not discharge the refrigerant into the atmosphere.
- Do not leave the system open for longer than 15 min. when replacing or servicing parts. The Polyol Ester (POE) oils used in R-404A applications can absorb moisture quickly. Therefore it is important to prevent moisture from entering the system when replacing or servicing parts.
- Always install a new drier every time the sealed refrigeration system is opened. Do not replace the drier until after all other repair or replacement has been made. Install the new drier with the arrow on the drier in the direction of the refrigerant flow.
- When brazing, protect the drier by using a wet cloth to prevent the drier from overheating. Do not allow the drier to exceed 250°F (121°C).

#### 1. Refrigerant Recovery

The icemaker is provided with refrigerant access valves. Using proper refrigerant practices, recover the refrigerant. Store the refrigerant in an approved container. Do not discharge the refrigerant into the atmosphere.

## 2. Brazing

### **⚠ WARNING**

- R-404A itself is not flammable at atmospheric pressure and temperatures up to 176°F (80°C).
- R-404A itself is not explosive or poisonous. However, when exposed to high temperatures (open flames), R-404A can be decomposed to form hydrofluoric acid and carbonyl fluoride both of which are hazardous.
- Do not use silver alloy or copper alloy containing arsenic.

- 1) Braze all fittings while purging with nitrogen gas flowing at a pressure of 3 to 4 PSIG.  
Note: Because the pipes in the evaporator case are specially coated to resist corrosion, it is important to make connections outside the evaporator case when possible. If it is necessary to braze inside the evaporator case, use sandpaper to remove the coating from the brazing connections before unbrazing the components.

### **NOTICE**

- Always install a new drier every time the sealed refrigeration system is opened.
- Do not replace the drier until after all other repair or replacement has been made. Install the new drier with the arrow on the drier in the direction of the refrigerant flow.
- When brazing, protect the drier by using a wet cloth to prevent the drier from overheating. Do not allow the drier to exceed 250°F (121°C).

- 2) Use an electronic leak detector or soap bubbles to check for leaks. Add a trace of refrigerant to the system (if using an electronic leak detector), and then raise the pressure using nitrogen gas (140 PSIG). Do not use R-404A as a mixture with pressurized air for leak testing.

## 3. Evacuation and Recharge (R-404A)

- 1) Attach a vacuum pump to the system. Be sure to connect the charging hoses to both high and low-side refrigerant access valves.

### **IMPORTANT**

The vacuum level and vacuum pump may be the same as those for current refrigerants. However, the rubber hose and gauge manifold to be used for evacuation and refrigerant charge should be exclusively for POE oils.

- 2) Turn on the vacuum pump. Open the gauge manifold valves. Never allow the oil in the vacuum pump to flow backwards.
- 3) Allow the vacuum pump to pull down to a 29.9" Hg vacuum. Evacuating period depends on pump capacity.
- 4) Close the low-side valve and high-side valve on the gauge manifold.

- 5) Disconnect the gauge manifold hose from the vacuum pump and attach it to a refrigerant service cylinder. Remember to loosen the connection and purge the air from the hose. For the required refrigerant charge, see the rating label inside the icemaker. Hoshizaki recommends only virgin refrigerant or reclaimed refrigerant which meets ARI Standard 700 (latest edition) be used.
- 6) A liquid charge is required when charging an R-404A system (to prevent fractionation). Place the service cylinder on the scales; if the service cylinder is not equipped with a dip tube, invert the service cylinder, then place it on the scales. Open the high-side valve on the gauge manifold.
- 7) Allow the system to charge with liquid until the proper charge weight is met.
- 8) If necessary, add any remaining charge to the system through the low-side.  
**NOTICE! To prevent compressor damage, use a throttling valve or liquid dispensing device to add the remaining liquid charge through the low-side refrigerant access valve with the icemaker running.**
- 9) Close the high and low-side gauge manifold valves, then disconnect the gauge manifold hoses.
- 10) Cap the refrigerant access valves to prevent a possible leak.

## B. Component Service Information

### NOTICE

When replacing a component listed below, see the notes to help ensure proper operation.

Component	Notes
Compressor	1 phase: Install a new start capacitor, run capacitor, and start relay. 3 phase: Install a new magnetic contactor.
Thermostatic Expansion Valves	<ul style="list-style-type: none"> <li>• Attach the thermostatic expansion valve bulb to the suction line in the same location as the previous bulb.</li> <li>• The bulb should be between the 10 and 2 o'clock positions on the tube.</li> <li>• Secure the bulb with the clamp and holder, then insulate it.</li> </ul>
Hot Gas Valves Liquid Line Valves	<ul style="list-style-type: none"> <li>• Replace the strainer if applicable.</li> <li>• Use copper tube of the same diameter and length when replacing valve lines.</li> </ul>
Fan Motors	Install a new capacitor.
Pump Motor	Install a new capacitor.
Thermistor	<ul style="list-style-type: none"> <li>• Attach the new thermistor to the suction line in the same location as the previous thermistor.</li> <li>• The thermistor should be at the 12 o'clock position on the tube.</li> <li>• Smoothly fill the recessed area of the thermistor holder with high thermal conductive type sealant. Hoshizaki America part number <a href="#">4A0683-01</a> (Silicone Heat Sink Compound 10-8108 manufactured by GC Electronics), KE-4560 RTV (manufactured by ShinEtsu Silicones), or equivalent are recommended.</li> <li>• Secure the thermistor with the holder, then insulate it.</li> <li>• Be very careful to prevent damage to the leads.</li> </ul>

## C. Water Regulating Valve Adjustment (water-cooled model)

The water regulating valve is factory set, and generally no adjustment is required. However, when necessary, adjust the water regulator using the following procedure.

- 1) Prepare a thermometer to check the condenser drain temperature. Attach a pressure gauge to the high-side line of the system.
- 2) 5 min. after a freeze cycle starts, confirm that the thermometer reads 104°F to 115°F (40°C to 46°C). If it does not, rotate the adjustment screw by using a flat blade screwdriver until the temperature is in the proper range. See Fig. 5. Next, check that the reference pressure is in the range indicated in the Head Pressure table in the Performance Data section. If it is not in the proper range, verify the refrigerant charge.
- 3) Check that the condenser drain temperature is stable.

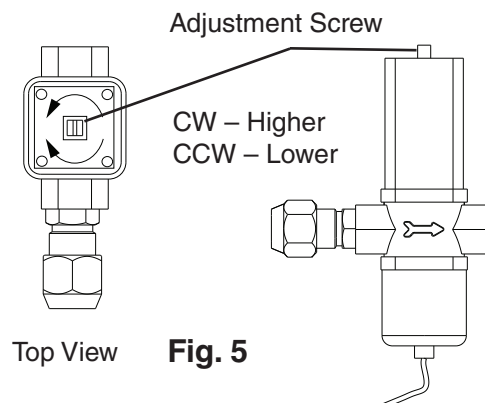

## V. Maintenance

The maintenance schedule below is a guideline. More frequent maintenance may be required depending on water quality, the appliance's environment, and local sanitation regulations

<b>⚠ WARNING</b>	
<ul style="list-style-type: none"> <li>• Only qualified service technicians should service the appliance.</li> <li>• To reduce the risk of electric shock, do not touch the control switch or service switch with damp hands</li> <li>• Before servicing: Move the control switch to the "OFF" position and turn off the power supply. Place the disconnect in the "OFF" position. Lockout/Tagout to prevent the power supply from being turned back on inadvertently.</li> <li>• <b>CHOKING HAZARD:</b> Ensure all components, fasteners, and thumbscrews are securely in place after any maintenance is done to the icemaker. Make sure that none have fallen into the dispenser unit/ice storage bin.</li> </ul>	

<b>Maintenance Schedule</b>		
<b>Frequency</b>	<b>Area</b>	<b>Task</b>
Daily	Scoop	Clean the ice scoop using a neutral cleaner. Rinse thoroughly after cleaning.
Bi-Weekly	Air Filters	Inspect. Wash with warm water and neutral cleaner if dirty.
Monthly	External Water Filters	Check for proper pressure and change if necessary.
	Icemaker Exterior	Wipe down with a clean, soft cloth. Use a damp cloth containing a neutral cleaner to wipe off oil or dirt build up. Clean any chlorine staining (rust colored spots) using a non-abrasive cleanser.
	Underside of Icemaker and Top Kits; Bin Door and Snout	Wipe down with a clean cloth and warm water.
Yearly	Icemaker and Dispenser Unit/Ice Storage Bin Liner	Clean and sanitize per the cleaning and sanitizing instructions provided in the instruction manual or maintenance label on the icemaker.
	Water Supply Inlet	Close the icemaker water supply line shut-off valve and drain the water system. Clean the water supply inlet screen.
	Condenser	Inspect. Clean if necessary by using a brush or vacuum cleaner. More frequent cleaning may be required depending on location.
	Water Hoses	Inspect the water hoses and clean/replace if necessary.

## VI. Preparing the Appliance for Periods of Non-Use

### NOTICE

- When storing the appliance for an extended time or in sub-freezing temperatures, follow the instructions below to prevent damage.
- To prevent damage to the water pump, do not operate the appliance with the control switch in the "WASH" position when the water tank is empty.

When the appliance is not used for two or three days under normal conditions, it is sufficient to move the control switch to the "OFF" position. When storing the appliance for an extended time or in sub-freezing temperatures, follow the instructions below.

#### 1. Remove the water from the icemaker water line:

- 1) Turn off the power supply, then remove the front panel.
- 2) Close the icemaker water supply line shut-off valve and open the icemaker water supply line drain valve.
- 3) Allow the line to drain by gravity.
- 4) Attach a compressed air or carbon dioxide supply to the icemaker water supply line drain valve.
- 5) Make sure at least 3 min. have elapsed since you turned off the power supply. Make sure the control switch is in the "ICE" position. Replace the front panel in its correct position, then turn on the power supply.
- 6) Blow the icemaker water supply line out using the compressed air or carbon dioxide supply.
- 7) Close the icemaker water supply line drain valve.

#### 2. Remove the water from the water tank:

- 1) Turn off the power supply, then remove the front panel.
- 2) Move the control switch to the "OFF" position.
- 3) Drain the water tank.

a) On KM-320M\_H, KM-515M\_H, KM-600M\_H, KM-650M\_H, and KM-901M\_H, remove the base cover, then disconnect one end of the pump tubing to drain the water tank. See Fig. 6. After the water tank has drained, reconnect the pump tubing.

b) On KM-1340M\_H and KM-1601M\_H, remove the rubber cap covering the overflow pipe in the water tank. Remove the overflow pipe by turning it counterclockwise. After the water tank has drained, replace the overflow pipe and the rubber cap in their correct positions. Note: Be sure the overflow pipe o-ring is in its correct position on the overflow pipe.

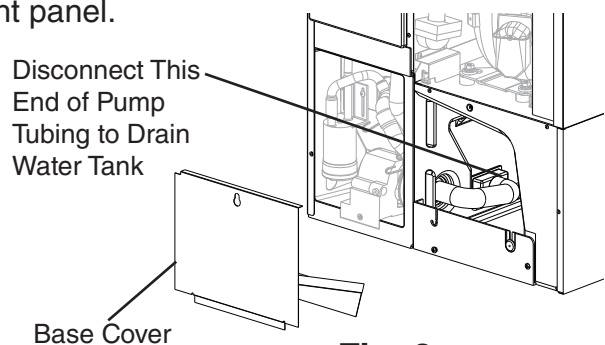

**Fig. 6**

- 4) Replace the base cover (if applicable) and front panel in their correct positions.
- 5) Remove all ice from the dispensing unit/ice storage bin. Clean the storage bin liner using a neutral cleaner. Rinse thoroughly after cleaning.

**3. On water-cooled model, remove the water from the water-cooled condenser:**

- 1) Make sure the power supply is off, then remove the front panel and right side panel.
- 2) Close the condenser water supply line shut-off valve. If connected to a closed loop system, also close the condenser return line shut-off valve.
- 3) Open the condenser water supply line drain valve. If connected to a closed loop system, also open the condenser return line drain valve.
- 4) Attach a compressed air or carbon dioxide supply to the condenser water supply line drain valve.
- 5) Open the water regulating valve by using a screwdriver to pry up on the spring retainer underneath the spring. While holding the valve open, blow out the condenser using the compressed air or carbon dioxide supply until water stops coming out.
- 6) Close the drain valve(s).
- 7) Replace the right side panel and front panel in their correct positions.

---

## **VII. Disposal**

The appliance contains refrigerant and must be disposed of in accordance with applicable national, state, and local codes and regulations. Refrigerant must be recovered by properly certified service personnel.

## VIII. Technical Information

We reserve the right to make changes in specifications and design without prior notice.

### A. Specification and Performance Data Sheets

Pressure data is recorded at 5 min. into freezing cycle. The data not in bold should be used for reference only.

#### 1. KM-320MAH

##### Specifications

AC SUPPLY VOLTAGE	115/60/1	
AMPERAGE	9.7 A (5 Min. Freeze AT 104°F/WT 80°F)	
MINIMUM CIRCUIT AMPACITY	20 A	
MAXIMUM FUSE SIZE	20 A	
ELECTRIC & WATER CONSUMPTION	90/70°F	70/50°F
ELECTRIC W (kWH/100 lbs.)	770(7.5)	730(5.6)
WATER gal./24HR (gal./100 lbs.)	77(31.2)	117(35.9)
ICE PRODUCTION PER CYCLE	7.2 lbs. (3.3 kg) 360 pcs.	
BIN CONTROL SYSTEM	Thermostat or Mechanical Bin Control	
REFRIGERANT CHARGE	R-404A, 1 lb. 4.3 oz. (575g)	

##### Performance Data

APPROXIMATE ICE PRODUCTION PER 24 HR.	AMBIENT TEMP. (°F/°C)	WATER TEMP. (°F/°C)					
		50/10		70/21		90/32	
	70/21	<b>310</b>	<u>141</u>	291	<u>132</u>	265	<u>120</u>
	80/27	296	<u>134</u>	267	<u>121</u>	239	<u>109</u>
	90/32	291	<u>132</u>	<b>246</b>	<u>112</u>	218	<u>99</u>
lbs./day kg./day	100/38	286	<u>130</u>	240	<u>109</u>	193	<u>88</u>
APPROXIMATE ELECTRIC CONSUMPTION	70/21	<b>730</b>		742		761	
	80/27	739		757		778	
	90/32	742		<b>770</b>		791	
watts	100/38	747		775		810	
APPROXIMATE WATER CONSUMPTION PER 24 HR.	70/21	<b>173</b>	<u>0.65</u>	145	<u>0.55</u>	126	<u>0.48</u>
	80/27	151	<u>0.57</u>	108	<u>0.41</u>	100	<u>0.38</u>
	90/32	145	<u>0.55</u>	<b>77</b>	<u>0.29</u>	64	<u>0.24</u>
gal./day m <sup>3</sup> /day	100/38	111	<u>0.42</u>	74	<u>0.28</u>	53	<u>0.20</u>
FREEZING CYCLE TIME	70/21	<b>33</b>		35		39	
	80/27	35		38		43	
	90/32	35		<b>41</b>		46	
min.	100/38	36		42		50	
HARVEST CYCLE TIME	70/21	<b>5.2</b>		4.4		4.0	
	80/27	4.6		3.3		3.4	
	90/32	4.4		<b>2.4</b>		2.3	
min.	100/38	3.5		2.3		2.2	
HEAD PRESSURE	70/21	<b>237</b>	<u>16.7</u>	256	<u>18.0</u>	279	<u>19.6</u>
	80/27	251	<u>17.7</u>	280	<u>19.7</u>	302	<u>21.2</u>
	90/32	256	<u>18.0</u>	<b>301</b>	<u>21.2</u>	323	<u>22.7</u>
PSIG kg/cm <sup>2</sup> G	100/38	259	<u>18.2</u>	306	<u>21.5</u>	344	<u>24.2</u>
SUCTION PRESSURE	70/21	<b>59</b>	<u>4.1</u>	60	<u>4.2</u>	62	<u>4.3</u>
	80/27	60	<u>4.2</u>	61	<u>4.3</u>	63	<u>4.4</u>
	90/32	60	<u>4.2</u>	<b>62</b>	<u>4.4</u>	64	<u>4.5</u>
PSIG kg/cm <sup>2</sup> G	100/38	60	<u>4.3</u>	62	<u>4.4</u>	66	<u>4.6</u>

TOTAL HEAT OF REJECTION FROM CONDENSER 6,700 BTU/h [AT 90°F (32°C) / WT 70°F (21°C)]

## 2. KM-320MWH

### Specification Sheet

AC SUPPLY VOLTAGE	115/60/1	
AMPERAGE	8.2 A (5 Min. Freeze AT 104°F / WT 80°F)	
MINIMUM CIRCUIT AMPACITY	20 A	
MAXIMUM FUSE SIZE	20 A	
ELECTRIC & WATER CONSUMPTION	90/70°F	70/50°F
ELECTRIC W (kWH/100 lbs.)	690(5.2)	710(4.9)
WATER gal./24HR (gal./100 lbs.)	70(21.9)	146(41.5)
WATER COOLED CONDENSER gal./24HR (gal./100 lbs.)	384(121)	193(55)
ICE PRODUCTION PER CYCLE	8.6 lbs. (3.9 kg) 360 pcs.	
BIN CONTROL SYSTEM	Thermostat or Mechanical Bin Control	
REFRIGERANT CHARGE	R-404A, 1 lb. 0.8 oz. (475g)	

### Performance Data

APPROXIMATE ICE PRODUCTION PER 24 HR.	AMBIENT TEMP (°F/°C)	WATER TEMP. (°F/°C)					
		50/10		70/21		90/32	
	70/21	<b>351</b>	<u>159</u>	341	<u>155</u>	320	<u>145</u>
	80/27	344	<u>156</u>	329	<u>149</u>	302	<u>137</u>
	90/32	341	<u>155</u>	<b>318</b>	<u>144</u>	293	<u>133</u>
lbs./day kg./day	100/38	334	<u>152</u>	312	<u>142</u>	270	<u>122</u>
APPROXIMATE ELECTRIC CONSUMPTION	70/21	<b>710</b>		704	714		
	80/27	706		696	716		
	90/32	704		<b>690</b>	706		
watts	100/38	712		694	720		
APPROXIMATE WATER CONSUMPTION PER 24 HR.	70/21	<b>339</b>	<u>1.28</u>	372	<u>1.41</u>	589	<u>2.23</u>
	80/27	364	<u>1.38</u>	417	<u>1.58</u>	727	<u>2.75</u>
	90/32	372	<u>1.41</u>	<b>453</b>	<u>1.72</u>	729	<u>2.76</u>
gal./day m <sup>3</sup> /day	100/38	495	<u>1.88</u>	518	<u>1.96</u>	982	<u>3.72</u>
FREEZING CYCLE TIME	70/21	<b>32</b>		33	35		
	80/27	33		35	37		
	90/32	33		<b>36</b>	39		
min.	100/38	34		37	41		
HARVEST CYCLE TIME	70/21	<b>4.3</b>		3.7	3.5		
	80/27	3.9		3.0	3.0		
	90/32	3.7		<b>2.3</b>	2.2		
min.	100/38	3.1		2.3	2.2		
HEAD PRESSURE	70/21	<b>269</b>	<u>18.9</u>	270	<u>19.0</u>	273	<u>19.2</u>
	80/27	270	<u>19.0</u>	272	<u>19.1</u>	276	<u>19.4</u>
	90/32	270	<u>19.0</u>	<b>273</b>	<u>19.2</u>	277	<u>19.5</u>
PSIG kg/cm <sup>2</sup> G	100/38	271	<u>19.1</u>	274	<u>19.3</u>	280	<u>19.7</u>
SUCTION PRESSURE	70/21	<b>56</b>	<u>3.9</u>	57	<u>4.0</u>	58	<u>4.1</u>
	80/27	57	<u>4.0</u>	59	<u>4.1</u>	59	<u>4.2</u>
	90/32	57	<u>4.0</u>	<b>61</b>	<u>4.3</u>	61	<u>4.3</u>
PSIG kg/cm <sup>2</sup> G	100/38	57	<u>4.0</u>	61	<u>4.3</u>	62	<u>4.3</u>

TOTAL HEAT OF REJECTION FROM CONDENSER	5,800 BTU/h [AT 90°F (32°C) / WT 70°F (21°C)]
TOTAL HEAT OF REJECTION FROM COMPRESSOR	1,000 BTU/h [AT 90°F (32°C) / WT 70°F (21°C)]
WATER FLOW FOR CONDENSER	38.5 gal./h [AT 100°F (38°C) / WT 90°F (32°C)]
PRESSURE DROP OF COOLING WATER LINE	less than 10 PSIG

### 3. KM-340MAH

#### Specification Sheet

AC SUPPLY VOLTAGE	115/60/1	
AMPERAGE	9.7 A ( 5 Min. Freeze AT 104°F / WT 80°F)	
MINIMUM CIRCUIT AMPACITY	20 A	
MAXIMUM FUSE SIZE	20 A	
ELECTRIC & WATER CONSUMPTION	90/70°F	70/50°F
ELECTRIC W (kWH/100 lbs.)	810(5.99)	750(4.68)
WATER gal./24HR (gal./100 lbs.)	65(20.0)	153(39.5)
ICE PRODUCTION PER CYCLE	11.3 lbs. (5.1 kg) 480pcs.	
BIN CONTROL SYSTEM	Mechanical Bin Control	
REFRIGERANT CHARGE	R404A, 1 lb. 8 oz. (680g)	

#### Performance Data

APPROXIMATE ICE PRODUCTION PER 24 HR.	AMBIENT TEMP. (°F/°C)	WATER TEMP. (°F/°C)					
		50/10		70/21		90/32	
	70/21	<b>387</b>	<u>176</u>	369	<u>167</u>	331	<u>150</u>
	80/27	373	<u>169</u>	345	<u>156</u>	301	<u>136</u>
	90/32	369	<u>167</u>	<b>325</b>	<u>147</u>	283	<u>128</u>
lbs./day <u>kg./day</u>	100/38	357	<u>162</u>	315	<u>143</u>	244	<u>111</u>
APPROXIMATE ELECTRIC CONSUMPTION	70/21	<b>750</b>		768		785	
	80/27	763		791		804	
	90/32	768		<b>810</b>		826	
watts	100/38	769		814		840	
APPROXIMATE WATER CONSUMPTION PER 24 HR.	70/21	<b>153</b>	<u>0.58</u>	127	<u>0.48</u>	105	<u>0.40</u>
	80/27	133	<u>0.50</u>	93	<u>0.35</u>	78	<u>0.30</u>
	90/32	127	<u>0.48</u>	<b>65</b>	<u>0.25</u>	46	<u>0.18</u>
gal./day <u>m<sup>3</sup>/day</u>	100/38	94	<u>0.36</u>	61	<u>0.23</u>	29	<u>0.11</u>
FREEZING CYCLE TIME	70/21	<b>39</b>		42		46	
	80/27	41		46		50	
	90/32	42		<b>49</b>		53	
min.	100/38	43		50		57	
HARVEST CYCLE TIME	70/21	<b>4.2</b>		3.7		3.4	
	80/27	3.8		3.0		2.9	
	90/32	3.7		<b>2.5</b>		2.3	
min.	100/38	3.1		2.5		2.1	
HEAD PRESSURE	70/21	<b>220</b>	<u>15.5</u>	241	<u>16.9</u>	259	<u>18.2</u>
	80/27	236	<u>16.6</u>	268	<u>18.8</u>	280	<u>19.7</u>
	90/32	241	<u>16.9</u>	<b>290</b>	<u>20.4</u>	306	<u>21.5</u>
PSIG <u>kg/cm<sup>2</sup>G</u>	100/38	241	<u>16.9</u>	294	<u>20.6</u>	320	<u>22.5</u>
SUCTION PRESSURE	70/21	<b>50</b>	<u>3.5</u>	53	<u>3.7</u>	56	<u>3.9</u>
	80/27	52	<u>3.7</u>	57	<u>4.0</u>	59	<u>4.2</u>
	90/32	53	<u>3.7</u>	<b>60</b>	<u>4.2</u>	63	<u>4.4</u>
PSIG <u>kg/cm<sup>2</sup>G</u>	100/38	53	<u>3.7</u>	61	<u>4.3</u>	65	<u>4.6</u>

TOTAL HEAT OF REJECTION FROM CONDENSER 6,700 BTU/h [AT 90°F (32°C) / WT 70°F (21°C)]

## 4. KM-340MWH

### Specification Sheet

AC SUPPLY VOLTAGE	115/60/1	
AMPERAGE	7.4A ( 5 Min. Freeze AT 104°F / WT 80°F)	
MINIMUM CIRCUIT AMPACITY	20 A	
MAXIMUM FUSE SIZE	20 A	
ELECTRIC & WATER CONSUMPTION	90/70°F	70/50°F
ELECTRIC W (kWH/100 lbs.)	730(4.85)	730(4.52)
WATER gal./24HR (gal./100 lbs.)	74(20.5)	152(39.3)
WATER COOLED CONDENSER gal./24HR (gal./100 lbs.)	414(115)	181(47)
ICE PRODUCTION PER CYCLE	11.3 lbs. (5.1 kg) 480pcs.	
BIN CONTROL SYSTEM	Mechanical Bin Control	
REFRIGERANT CHARGE	R404A, 1 lb. 0.8 oz. (475g)	

### Performance Data

APPROXIMATE ICE PRODUCTION PER 24 HR.	AMBIENT TEMP. (°F/°C)	WATER TEMP. (°F/°C)					
		50/10		70/21		90/32	
	70/21	<b>386</b>	<u>175</u>	378	<u>172</u>	360	<u>163</u>
	80/27	380	<u>172</u>	368	<u>167</u>	346	<u>157</u>
	90/32	378	<u>172</u>	<b>360</b>	<u>163</u>	339	<u>154</u>
lbs./day kg./day	100/38	372	<u>169</u>	355	<u>161</u>	320	<u>145</u>
APPROXIMATE ELECTRIC CONSUMPTION	70/21	<b>730</b>		730		734	
	80/27	730		730		736	
	90/32	730		<b>730</b>		735	
watts	100/38	732		731		740	
APPROXIMATE WATER CONSUMPTION PER 24 HR.	70/21	<b>332</b>	<u>1.26</u>	378	<u>1.43</u>	769	<u>2.91</u>
	80/27	367	<u>1.39</u>	438	<u>1.66</u>	1012	<u>3.83</u>
	90/32	378	<u>1.43</u>	<b>488</b>	<u>1.85</u>	993	<u>3.76</u>
gal./day m3/day	100/38	587	<u>2.22</u>	606	<u>2.29</u>	1457	<u>5.51</u>
FREEZING CYCLE TIME	70/21	<b>38</b>		39		42	
	80/27	39		41		44	
	90/32	39		<b>42</b>		45	
min.	100/38	40		43		48	
HARVEST CYCLE TIME	70/21	<b>4.9</b>		4.3		3.9	
	80/27	4.5		3.5		3.4	
	90/32	4.3		<b>2.9</b>		2.6	
min.	100/38	3.6		2.8		2.3	
HEAD PRESSURE	70/21	<b>264</b>	<u>18.6</u>	264	<u>18.6</u>	267	<u>18.8</u>
	80/27	264	<u>18.6</u>	265	<u>18.6</u>	268	<u>18.9</u>
	90/32	264	<u>18.6</u>	<b>265</b>	<u>18.6</u>	268	<u>18.9</u>
PSIG kg/cm2G	100/38	265	<u>18.7</u>	266	<u>18.7</u>	271	<u>19.1</u>
SUCTION PRESSURE	70/21	<b>57</b>	<u>4.0</u>	58	<u>4.0</u>	61	<u>4.3</u>
	80/27	57	<u>4.0</u>	58	<u>4.1</u>	63	<u>4.4</u>
	90/32	58	<u>4.0</u>	<b>59</b>	<u>4.1</u>	63	<u>4.4</u>
PSIG kg/cm2G	100/38	59	<u>4.2</u>	60	<u>4.2</u>	67	<u>4.7</u>

TOTAL HEAT OF REJECTION FROM CONDENSER	7,500 BTU/h [AT 90°F (32°C) / WT 70°F (21°C)]
TOTAL HEAT OF REJECTION FROM COMPRESSOR	1,000 BTU/h [AT 90°F (32°C) / WT 70°F (21°C)]
WATER FLOW FOR CONDENSER	57 gal./h [AT 100°F (38°C) / WT 90°F (32°C)]
PRESSURE DROP OF COOLING WATER LINE	less than 10 PSIG

## 5. KM-515MAH

### Specification Sheet

AC SUPPLY VOLTAGE	115/60/1	
AMPERAGE	11.7 A (5 Min. Freeze AT 104°F/WT 80°F)	
MINIMUM CIRCUIT AMPACITY	20 A	
MAXIMUM FUSE SIZE	20 A	
ELECTRIC & WATER CONSUMPTION	90/70°F	70/50°F
ELECTRIC W (kWH/100 lbs.)	1110(5.9)	1010(4.6)
WATER gal./24HR (gal./100 lbs.)	83(18.5)	231(43.9)
ICE PRODUCTION PER CYCLE	10.2 lbs. (4.6 kg) 480pcs.	
BIN CONTROL SYSTEM	Thermostat or Mechanical Bin Control	
REFRIGERANT CHARGE	R404A, 1 lb. 7.3 oz. (660g)	

### Performance Data

APPROXIMATE ICE PRODUCTION PER 24 HR.	AMBIENT TEMP. (°F/°C)	WATER TEMP. (°F/°C)					
		50/10		70/21		90/32	
	70/21	<b>527</b>	<u>239</u>	504	<u>229</u>	474	<u>215</u>
	80/27	510	<u>231</u>	475	<u>215</u>	444	<u>201</u>
	90/32	504	<u>229</u>	<b>450</b>	<u>204</u>	419	<u>190</u>
lbs./day kg./day	100/38	498	<u>226</u>	443	<u>201</u>	390	<u>177</u>
APPROXIMATE ELECTRIC CONSUMPTION	70/21	<b>1010</b>		1039		1053	
	80/27	1032		1078		1076	
	90/32	1039		<b>1110</b>		1115	
watts	100/38	1033		1111		1120	
APPROXIMATE WATER CONSUMPTION PER 24 HR.	70/21	<b>231</b>	<u>0.88</u>	188	<u>0.71</u>	168	<u>0.64</u>
	80/27	198	<u>0.75</u>	131	<u>0.50</u>	133	<u>0.51</u>
	90/32	188	<u>0.71</u>	<b>83</b>	<u>0.32</u>	76	<u>0.29</u>
gal./day m <sup>3</sup> /day	100/38	140	<u>0.53</u>	82	<u>0.31</u>	69	<u>0.26</u>
FREEZING CYCLE TIME	70/21	<b>24</b>		26		28	
	80/27	25		28		31	
	90/32	26		<b>29</b>		32	
min.	100/38	26		30		35	
HARVEST CYCLE TIME	70/21	<b>3.9</b>		3.4		3.2	
	80/27	3.5		2.7		2.8	
	90/32	3.4		<b>2.1</b>		2.1	
min.	100/38	2.8		2.1		2.1	
HEAD PRESSURE	70/21	<b>234</b>	<u>16.5</u>	257	<u>18.1</u>	285	<u>20.0</u>
	80/27	252	<u>17.7</u>	288	<u>20.2</u>	313	<u>22.0</u>
	90/32	257	<u>18.1</u>	<b>313</b>	<u>22.0</u>	340	<u>23.9</u>
PSIG kg/cm <sup>2</sup> G	100/38	261	<u>18.4</u>	319	<u>22.4</u>	364	<u>25.6</u>
SUCTION PRESSURE	70/21	<b>47</b>	<u>3.3</u>	50	<u>3.5</u>	56	<u>3.9</u>
	80/27	49	<u>3.5</u>	54	<u>3.8</u>	61	<u>4.3</u>
	90/32	50	<u>3.5</u>	<b>58</b>	<u>4.1</u>	64	<u>4.5</u>
PSIG kg/cm <sup>2</sup> G	100/38	52	<u>3.6</u>	59	<u>4.2</u>	70	<u>4.9</u>

TOTAL HEAT OF REJECTION FROM CONDENSER

9,500 BTU/h [AT 90°F (32°C) / WT 70°F (21°C)]

## 6. KM-515MWH

### Specification Sheet

AC SUPPLY VOLTAGE	115/60/1	
AMPERAGE	9.6 A (5 Min. Freeze AT 104°F/WT 80°F)	
MINIMUM CIRCUIT AMPACITY	20 A	
MAXIMUM FUSE SIZE	20 A	
ELECTRIC & WATER CONSUMPTION	90/70°F	70/50°F
ELECTRIC W (kWH/100 lbs.)	960(5.14)	920(4.8)
WATER gal./24HR (gal./100 lbs.)	103(23.0)	180(39.0)
WATER COOLED CONDENSER gal./24HR (gal./100 lbs.)	473(106)	263(57)
ICE PRODUCTION PER CYCLE	10. lbs. (4.5 kg) 480pcs.	
BIN CONTROL SYSTEM	Thermostat or Mechanical Bin Control	
REFRIGERANT CHARGE	R404A, 0 lb. 14.8 oz. (420g)	

### Performance Data

APPROXIMATE ICE PRODUCTION PER 24 HR.	AMBIENT TEMP. (°F/°C)	WATER TEMP. (°F/°C)					
		50/10		70/21		90/32	
	70/21	<b>462</b>	<u>210</u>	457	<u>207</u>	427	<u>194</u>
	80/27	458	<u>208</u>	451	<u>205</u>	407	<u>185</u>
	90/32	457	<u>207</u>	<b>446</b>	<u>202</u>	407	<u>185</u>
lbs./day kg./day	100/38	443	<u>201</u>	437	<u>198</u>	371	<u>168</u>
APPROXIMATE ELECTRIC CONSUMPTION	70/21	<b>920</b>		932		932	
	80/27	929		947		938	
	90/32	932		<b>960</b>		955	
watts	100/38	926		959		950	
APPROXIMATE WATER CONSUMPTION PER 24 HR.	70/21	<b>444</b>	<u>1.68</u>	482	<u>1.83</u>	727	<u>2.75</u>
	80/27	473	<u>1.79</u>	533	<u>2.02</u>	884	<u>3.35</u>
	90/32	482	<u>1.83</u>	<b>575</b>	<u>2.18</u>	887	<u>3.36</u>
gal./day m3/day	100/38	622	<u>2.35</u>	648	<u>2.45</u>	1173	<u>4.44</u>
FREEZING CYCLE TIME	70/21	<b>28</b>		29		31	
	80/27	28		30		32	
	90/32	29		<b>31</b>		33	
min.	100/38	29		31		35	
HARVEST CYCLE TIME	70/21	<b>4.6</b>		4.0		3.9	
	80/27	4.2		3.4		3.5	
	90/32	4.0		<b>2.8</b>		2.8	
min.	100/38	3.5		2.8		2.8	
HEAD PRESSURE	70/21	<b>266</b>	<u>18.7</u>	267	<u>18.8</u>	270	<u>19.0</u>
	80/27	267	<u>18.7</u>	268	<u>18.8</u>	272	<u>19.1</u>
	90/32	267	<u>18.8</u>	<b>269</b>	<u>18.9</u>	273	<u>19.2</u>
PSIG kg/cm2G	100/38	268	<u>18.8</u>	270	<u>19.0</u>	276	<u>19.4</u>
SUCTION PRESSURE	70/21	<b>48</b>	<u>3.4</u>	50	<u>3.5</u>	55	<u>3.9</u>
	80/27	49	<u>3.5</u>	52	<u>3.7</u>	59	<u>4.1</u>
	90/32	50	<u>3.5</u>	<b>54</b>	<u>3.8</u>	60	<u>4.2</u>
PSIG kg/cm2G	100/38	52	<u>3.6</u>	55	<u>3.9</u>	66	<u>4.6</u>
TOTAL HEAT OF REJECTION FROM CONDENSER	8,200 BTU/h [AT 90°F (32°C) / WT 70°F (21°C)]						
TOTAL HEAT OF REJECTION FROM COMPRESSOR	1,300 BTU/h [AT 90°F (32°C) / WT 70°F (21°C)]						
WATER FLOW FOR CONDENSER	45 gal./h [AT 100°F (38°C) / WT 90°F (32°C)]						
PRESSURE DROP OF COOLING WATER LINE	less than 10 PSIG						

## 7. KM-515MRH with URC-5F

### Specification Sheet

AC SUPPLY VOLTAGE	115/60/1	
AMPERAGE	11.3A (5 Min. Freeze AT 104°F/WT 80°F)	
MINIMUM CIRCUIT AMPACITY	20 A	
MAXIMUM FUSE SIZE	20 A	
ELECTRIC & WATER CONSUMPTION	90/70°F	70/50°F
ELECTRIC W (kWH/100 lbs.)	1090(5.8)	1000(4.9)
WATER gal./24HR (gal./100 lbs.)	94(20.8)	198(40.4)
ICE PRODUCTION PER CYCLE	10.3 lbs. (4.7 kg) 480pcs.	
BIN CONTROL SYSTEM	Thermostat or Mechanical Bin Control	
TOTAL REFRIGERANT CHARGE	R404A, 4 lbs. 4.8 oz. (1950g)	
REFRIGERANT CHARGE BY UNIT	Icemaker 2 lbs. 6.8 oz. Cond. Unit 1 lbs. 14 oz.	

### Performance Data

APPROXIMATE ICE PRODUCTION PER 24 HR.	AMBIENT TEMP. (°F/°C)	WATER TEMP. (°F/°C)					
		50/10		70/21		90/32	
	70/21	<b>491</b>	<u>223</u>	480	<u>218</u>	443	<u>201</u>
	80/27	482	<u>219</u>	465	<u>211</u>	417	<u>189</u>
	90/32	480	<u>218</u>	<b>452</b>	<u>205</u>	408	<u>185</u>
lbs./day kg./day	100/38	465	<u>211</u>	442	<u>200</u>	368	<u>167</u>
APPROXIMATE ELECTRIC CONSUMPTION	70/21	<b>1000</b>		1026		1058	
	80/27	1020		1061		1091	
	90/32	1026		<b>1090</b>		1121	
watts	100/38	1031		1097		1150	
APPROXIMATE WATER CONSUMPTION PER 24 HR.	70/21	<b>198</b>	<u>0.75</u>	168	<u>0.64</u>	153	<u>0.58</u>
	80/27	175	<u>0.66</u>	128	<u>0.48</u>	128	<u>0.49</u>
	90/32	168	<u>0.64</u>	<b>94</b>	<u>0.36</u>	88	<u>0.33</u>
gal./day m3/day	100/38	133	<u>0.50</u>	93	<u>0.35</u>	82	<u>0.31</u>
FREEZING CYCLE TIME	70/21	<b>26</b>		27		30	
	80/27	27		29		32	
	90/32	27		<b>31</b>		34	
min.	100/38	28		31		36	
HARVEST CYCLE TIME	70/21	<b>5.0</b>		4.3		4.1	
	80/27	4.5		3.4		3.6	
	90/32	4.3		<b>2.7</b>		2.7	
min.	100/38	3.6		2.7		2.7	
HEAD PRESSURE	70/21	<b>216</b>	<u>15.2</u>	234	<u>16.4</u>	252	<u>17.7</u>
	80/27	230	<u>16.1</u>	257	<u>18.1</u>	272	<u>19.1</u>
	90/32	234	<u>16.4</u>	<b>277</b>	<u>19.5</u>	294	<u>20.6</u>
PSIG kg/cm2G	100/38	235	<u>16.6</u>	281	<u>19.8</u>	309	<u>21.7</u>
SUCTION PRESSURE	70/21	<b>47</b>	<u>3.3</u>	50	<u>3.5</u>	52	<u>3.6</u>
	80/27	49	<u>3.5</u>	54	<u>3.8</u>	54	<u>3.8</u>
	90/32	50	<u>3.5</u>	<b>57</b>	<u>4.0</u>	58	<u>4.1</u>
PSIG kg/cm2G	100/38	50	<u>3.5</u>	57	<u>4.0</u>	59	<u>4.1</u>

TOTAL HEAT OF REJECTION FROM CONDENSER	8,500 BTU/h [AT 90°F (32°C) / WT 70°F (21°C)]
TOTAL HEAT OF REJECTION FROM COMPRESSOR	1,400 BTU/h [AT 90°F (32°C) / WT 70°F (21°C)]
CONDENSER VOLUME	43 CU. IN (URC-5F)

## 8. KM-600MAH

### Specification Sheet

AC SUPPLY VOLTAGE	115-120/60/1	
AMPERAGE	12.0 A (5 Min. Freeze AT 104°F/WT 80°F)	
MINIMUM CIRCUIT AMPACITY	15 A	
MAXIMUM FUSE SIZE	15 A	
ELECTRIC & WATER CONSUMPTION	90/70°F	70/50°F
ELECTRIC W (kWH/100 lbs.)	1190(5.7)	1040(4.2)
WATER gal./24HR (gal./100 lbs.)	99(19.7)	259(43.7)
ICE PRODUCTION PER CYCLE	14.3 lbs. (6.5 kg) 720 pcs.	
BIN CONTROL SYSTEM	Thermostat or Mechanical Bin Control	
REFRIGERANT CHARGE	R-404A, 1 lb. 11 oz. (765g)	

### Performance Data

APPROXIMATE ICE PRODUCTION PER 24 HR.	AMBIENT TEMP. (°F/°C)	WATER TEMP. (°F/°C)					
		50/10		70/21		90/32	
	70/21	<b>592</b>	<u>269</u>	566	<u>257</u>	516	<u>234</u>
	80/27	572	<u>260</u>	532	<u>241</u>	474	<u>215</u>
	90/32	566	<u>257</u>	<b>503</b>	<u>228</u>	447	<u>203</u>
lbs./day kg./day	100/38	551	<u>250</u>	490	<u>222</u>	396	<u>180</u>
APPROXIMATE ELECTRIC CONSUMPTION	70/21	<b>1040</b>		1084		1102	
	80/27	1073		1142		1137	
	90/32	1084		<b>1190</b>		1195	
watts	100/38	1073		1191		1200	
APPROXIMATE WATER CONSUMPTION PER 24 HR.	70/21	<b>259</b>	<u>0.98</u>	212	<u>0.80</u>	191	<u>0.72</u>
	80/27	223	<u>0.84</u>	150	<u>0.57</u>	154	<u>0.58</u>
	90/32	212	<u>0.80</u>	<b>99</b>	<u>0.38</u>	92	<u>0.35</u>
gal./day m3/day	100/38	160	<u>0.61</u>	97	<u>0.37</u>	85	<u>0.32</u>
FREEZING CYCLE TIME	70/21	<b>33</b>		35		38	
	80/27	34		38		42	
	90/32	35		<b>40</b>		44	
min.	100/38	36		41		48	
HARVEST CYCLE TIME	70/21	<b>4.2</b>		3.6		3.4	
	80/27	3.7		2.7		2.9	
	90/32	3.6		<b>2.0</b>		2.0	
min.	100/38	2.9		2.0		2.0	
HEAD PRESSURE	70/21	<b>238</b>	<u>16.7</u>	259	<u>18.2</u>	290	<u>20.4</u>
	80/27	254	<u>17.9</u>	287	<u>20.2</u>	319	<u>22.4</u>
	90/32	259	<u>18.2</u>	<b>310</b>	<u>21.8</u>	342	<u>24.1</u>
PSIG kg/cm2G	100/38	266	<u>18.7</u>	318	<u>22.3</u>	372	<u>26.2</u>
SUCTION PRESSURE	70/21	<b>55</b>	<u>3.9</u>	56	<u>4.0</u>	58	<u>4.1</u>
	80/27	56	<u>3.9</u>	58	<u>4.0</u>	60	<u>4.2</u>
	90/32	56	<u>4.0</u>	<b>59</b>	<u>4.1</u>	61	<u>4.3</u>
PSIG kg/cm2G	100/38	57	<u>4.0</u>	59	<u>4.2</u>	62	<u>4.4</u>

TOTAL HEAT OF REJECTION FROM CONDENSER 9,500 BTU/h [AT 90°F (32°C) / WT 70°F (21°C)]

## 9. KM-650MAH

### Specification Sheet

AC SUPPLY VOLTAGE	208-230/60/1 (3 wire with neutral) or 208-230/60/1	
AMPERAGE	7.2 A (5 Min. Freeze AT 104°F/WT 80°F)	
MINIMUM CIRCUIT AMPACITY	15 A	
MAXIMUM FUSE SIZE	15 A	
ELECTRIC & WATER CONSUMPTION	90/70°F	70/50°F
ELECTRIC W (kWH/100 lbs.)	1290(5.51)	1180(4.30)
WATER gal./24HR (gal./100 lbs.)	101(18.0)	232(35.1)
ICE PRODUCTION PER CYCLE	14.6 lbs. (6.6 kg) 720 pcs.	
BIN CONTROL SYSTEM	Thermostat or Mechanical Bin Control	
REFRIGERANT CHARGE	R-404A, 1 lb. 8 oz. (680g)	

### Performance Data

APPROXIMATE ICE PRODUCTION PER 24 HR.	AMBIENT TEMP. (°F/°C)	WATER TEMP. (°F/°C)					
		50/10		70/21		90/32	
	70/21	<b>661</b>	<u>300</u>	632	<u>287</u>	591	<u>268</u>
	80/27	639	<u>290</u>	594	<u>269</u>	553	<u>251</u>
	90/32	632	<u>287</u>	<b>562</b>	<u>255</u>	520	<u>236</u>
lbs./day kg./day	100/38	624	<u>283</u>	552	<u>250</u>	482	<u>219</u>
APPROXIMATE ELECTRIC CONSUMPTION	70/21	<b>1180</b>		1212		1250	
	80/27	1205		1255		1289	
	90/32	1212		<b>1290</b>		1326	
watts	100/38	1218		1299		1360	
APPROXIMATE WATER CONSUMPTION PER 24 HR.	70/21	<b>232</b>	<u>0.88</u>	194	<u>0.73</u>	172	<u>0.65</u>
	80/27	203	<u>0.77</u>	143	<u>0.54</u>	139	<u>0.53</u>
	90/32	194	<u>0.73</u>	<b>101</b>	<u>0.38</u>	89	<u>0.34</u>
gal./day m3/day	100/38	149	<u>0.56</u>	98	<u>0.37</u>	78	<u>0.30</u>
FREEZING CYCLE TIME	70/21	<b>29</b>		31		34	
	80/27	30		34		36	
	90/32	31		<b>36</b>		38	
min.	100/38	32		36		41	
HARVEST CYCLE TIME	70/21	<b>3.5</b>		3.1		2.9	
	80/27	3.2		2.5		2.6	
	90/32	3.1		<b>2.0</b>		2.0	
min.	100/38	2.6		2.0		2.0	
HEAD PRESSURE	70/21	<b>232</b>	<u>16.3</u>	252	<u>17.8</u>	280	<u>19.7</u>
	80/27	248	<u>17.4</u>	280	<u>19.7</u>	307	<u>21.6</u>
	90/32	252	<u>17.8</u>	<b>302</b>	<u>21.3</u>	331	<u>23.2</u>
PSIG kg/cm2G	100/38	258	<u>18.1</u>	309	<u>21.7</u>	357	<u>25.1</u>
SUCTION PRESSURE	70/21	<b>50</b>	<u>3.5</u>	52	<u>3.7</u>	55	<u>3.9</u>
	80/27	52	<u>3.6</u>	56	<u>3.9</u>	58	<u>4.1</u>
	90/32	52	<u>3.7</u>	<b>58</b>	<u>4.1</u>	61	<u>4.3</u>
PSIG kg/cm2G	100/38	53	<u>3.7</u>	59	<u>4.1</u>	64	<u>4.5</u>

TOTAL HEAT OF REJECTION FROM CONDENSER 11,100 BTU/h [AT 90°F (32°C) / WT 70°F (21°C)]

## 10. KM-650MWH

### Specification Sheet

AC SUPPLY VOLTAGE	208-230/60/1 (3 wire with neutral) or 208-230/60/1	
AMPERAGE	5.4 A (5 Min. Freeze AT 104°F/WT 80°F)	
MINIMUM CIRCUIT AMPACITY	15 A	
MAXIMUM FUSE SIZE	15 A	
ELECTRIC & WATER CONSUMPTION	90/70°F	70/50°F
ELECTRIC W (kWH/100 lbs.)	1130(4.16)	1120(4.03)
WATER gal./24HR (gal./100 lbs.)	145(22.3)	286(42.7)
WATER COOLED CONDENSER	982(151)	503(75)
gal./24HR (gal./100 lbs.)		
ICE PRODUCTION PER CYCLE	14.3 lbs. (6.5 kg) 720 pcs.	
BIN CONTROL SYSTEM	Thermostat or Mechanical Bin Control	
REFRIGERANT CHARGE	R-404A, 1 lb. 5.2 oz. (600g)	

### Performance Data

APPROXIMATE ICE PRODUCTION PER 24 HR.	AMBIENT TEMP. (°F/°C)	WATER TEMP. (°F/°C)					
		50/10		70/21		90/32	
	70/21	<b>669</b>	<u>303</u>	663	<u>301</u>	626	<u>284</u>
	80/27	665	<u>302</u>	656	<u>298</u>	602	<u>273</u>
	90/32	663	<u>301</u>	<b>650</b>	<u>295</u>	602	<u>273</u>
lbs./day kg./day	100/38	646	<u>293</u>	639	<u>290</u>	557	<u>253</u>
APPROXIMATE ELECTRIC CONSUMPTION	70/21	<b>1120</b>		1123		1139	
	80/27	1122		1127		1150	
	90/32	1123		<b>1130</b>		1151	
watts	100/38	1130		1135		1170	
APPROXIMATE WATER CONSUMPTION PER 24 HR.	70/21	<b>789</b>	<u>2.99</u>	888	<u>3.36</u>	1449	<u>5.49</u>
	80/27	864	<u>3.27</u>	1018	<u>3.85</u>	1816	<u>6.88</u>
	90/32	888	<u>3.36</u>	<b>1126</b>	<u>4.26</u>	1836	<u>6.95</u>
gal./day m3/day	100/38	1218	<u>4.61</u>	1293	<u>4.89</u>	2489	<u>9.42</u>
FREEZING CYCLE TIME	70/21	<b>28</b>		28		30	
	80/27	28		29		31	
	90/32	28		<b>30</b>		32	
min.	100/38	29		30		34	
HARVEST CYCLE TIME	70/21	<b>4.1</b>		3.6		3.3	
	80/27	3.7		3.0		2.9	
	90/32	3.6		<b>2.5</b>		2.3	
min.	100/38	3.1		2.4		2.1	
HEAD PRESSURE	70/21	<b>239</b>	<u>16.8</u>	240	<u>16.8</u>	248	<u>17.5</u>
	80/27	239	<u>16.8</u>	240	<u>16.9</u>	254	<u>17.8</u>
	90/32	240	<u>16.8</u>	<b>241</b>	<u>16.9</u>	252	<u>17.8</u>
PSIG kg/cm2G	100/38	244	<u>17.2</u>	244	<u>17.1</u>	263	<u>18.5</u>
SUCTION PRESSURE	70/21	<b>50</b>		50		53	
	80/27	50		51		54	
	90/32	50		<b>51</b>		54	
PSIG kg/cm2G	100/38	51		52		57	

TOTAL HEAT OF REJECTION FROM CONDENSER 9,200 BTU/h [AT 90°F (32°C) / WT 70°F (21°C)]

TOTAL HEAT OF REJECTION FROM COMPRESSOR 1,400 BTU/h [AT 90°F (32°C) / WT 70°F (21°C)]

WATER FLOW FOR CONDENSER 99.6 gal./h [AT 100°F (38°C) / WT 90°F (32°C)]

PRESSURE DROP OF COOLING WATER LINE less than 10 PSIG

## 11. KM-650MRH with URC-5F

### Specification Sheet

AC SUPPLY VOLTAGE	208-230/60/1 (3 wire with neutral) or 208-230/60/1	
AMPERAGE	7.4 A (5 Min. Freeze AT 104°F/WT 80°F)	
MINIMUM CIRCUIT AMPACITY	15 A	
MAXIMUM FUSE SIZE	15 A	
ELECTRIC & WATER CONSUMPTION	90/70°F	70/50°F
ELECTRIC W (kWH/100 lbs.)	1320(5.6)	1220(4.6)
WATER gal./24HR (gal./100 lbs.)	93(16.5)	267(42.2)
ICE PRODUCTION PER CYCLE	14.4 lbs. (6.5 kg) 720 pcs.	
BIN CONTROL SYSTEM	Thermostat or Mechanical Bin Control	
TOTAL REFRIGERANT CHARGE	R-404A, 5 lbs. 14.9 oz. (2690 g)	
REFRIGERANT CHARGE BY UNIT	Icemaker 4 lbs. 0.9 oz. Cond. Unit 1 lb. 14 oz.	

### Performance Data

APPROXIMATE ICE PRODUCTION PER 24 HR.	AMBIENT TEMP. (°F/°C)	WATER TEMP. (°F/°C)					
		50/10		70/21		90/32	
	70/21	<b>632</b>	<u>287</u>	612	<u>278</u>	574	<u>260</u>
	80/27	617	<u>280</u>	586	<u>266</u>	541	<u>246</u>
	90/32	612	<u>278</u>	<b>564</b>	<u>256</u>	521	<u>236</u>
lbs./day kg./day	100/38	601	<u>272</u>	554	<u>251</u>	482	<u>219</u>
APPROXIMATE ELECTRIC CONSUMPTION	70/21	<b>1220</b>		1249		1278	
	80/27	1242		1288		1311	
	90/32	1249		<b>1320</b>		1346	
watts	100/38	1251		1326		1370	
APPROXIMATE WATER CONSUMPTION PER 24 HR.	70/21	<b>267</b>	<u>1.01</u>	216	<u>0.82</u>	195	<u>0.74</u>
	80/27	228	<u>0.86</u>	149	<u>0.56</u>	155	<u>0.59</u>
	90/32	216	<u>0.82</u>	<b>93</b>	<u>0.35</u>	88	<u>0.33</u>
gal./day m3/day	100/38	160	<u>0.61</u>	92	<u>0.35</u>	82	<u>0.31</u>
FREEZING CYCLE TIME	70/21	<b>30</b>		32		34	
	80/27	31		33		36	
	90/32	32		<b>35</b>		37	
min.	100/38	32		35		39	
HARVEST CYCLE TIME	70/21	<b>4.1</b>		3.5		3.3	
	80/27	3.7		2.7		2.9	
	90/32	3.5		<b>2.1</b>		2.1	
min.	100/38	3.0		2.1		2.1	
HEAD PRESSURE	70/21	<b>211</b>	<u>14.9</u>	231	<u>16.3</u>	253	<u>17.8</u>
	80/27	227	<u>15.9</u>	258	<u>18.1</u>	277	<u>19.5</u>
	90/32	231	<u>16.3</u>	<b>280</b>	<u>19.7</u>	301	<u>21.1</u>
PSIG kg/cm2G	100/38	234	<u>16.5</u>	285	<u>20.0</u>	320	<u>22.5</u>
SUCTION PRESSURE	70/21	<b>51</b>	<u>3.6</u>	53	<u>3.7</u>	56	<u>3.9</u>
	80/27	52	<u>3.7</u>	55	<u>3.8</u>	58	<u>4.1</u>
	90/32	53	<u>3.7</u>	<b>56</b>	<u>3.9</u>	59	<u>4.2</u>
PSIG kg/cm2G	100/38	54	<u>3.8</u>	57	<u>4.0</u>	<b>62</b>	<u>4.4</u>

TOTAL HEAT OF REJECTION FROM CONDENSER	9600 BTU/h [AT 90°F (32°C) / WT 70°F (21°C)]
TOTAL HEAT OF REJECTION FROM COMPRESSOR	1500 BTU/h [AT 90°F (32°C) / WT 70°F (21°C)]
CONDENSER VOLUME	40 CU. IN (URC-5F)

## 12. KM-901MAH

### Specification Sheet

AC SUPPLY VOLTAGE	208-230/60/1 (3 wire with neutral) or 208-230/60/1	
AMPERAGE	11.4 A (5 Min. Freeze AT 104°F/WT 80°F)	
MINIMUM CIRCUIT AMPACITY	20 A	
MAXIMUM FUSE SIZE	20 A	
ELECTRIC & WATER CONSUMPTION	90/70°F	70/50°F
ELECTRIC W (kWH/100 lbs.)	1740(5.1)	1670(4.4)
WATER gal./24HR (gal./100 lbs.)	130(16.0)	292(31.7)
ICE PRODUCTION PER CYCLE	14.2 lbs. (6.5 kg) 720pcs.	
BIN CONTROL SYSTEM	Thermostat or Mechanical Bin Control	
REFRIGERANT CHARGE	R404A, 2 lb. 15 oz. (1323g)	

### Performance Data

APPROXIMATE ICE PRODUCTION PER 24 HR.	AMBIENT TEMP. (°F/°C)	WATER TEMP. (°F/°C)					
		50/10		70/21		90/32	
	70/21	<b>920</b>	<u>417</u>	889	<u>403</u>	841	<u>381</u>
	80/27	896	<u>406</u>	847	<u>384</u>	797	<u>361</u>
	90/32	889	<u>403</u>	<b>813</b>	<u>369</u>	762	<u>346</u>
lbs./day kg./day	100/38	877	<u>398</u>	801	<u>363</u>	716	<u>325</u>
APPROXIMATE ELECTRIC CONSUMPTION	70/21	<b>1670</b>		1691		1732	
	80/27	1686		1718		1767	
	90/32	1691		<b>1740</b>		1787	
watts	100/38	1703		1751		1830	
APPROXIMATE WATER CONSUMPTION PER 24 HR.	70/21	<b>292</b>	<u>1.10</u>	244	<u>0.92</u>	215	<u>0.81</u>
	80/27	256	<u>0.97</u>	182	<u>0.69</u>	172	<u>0.65</u>
	90/32	244	<u>0.92</u>	<b>130</b>	<u>0.49</u>	111	<u>0.42</u>
gal./day m3/day	100/38	188	<u>0.71</u>	126	<u>0.48</u>	94	<u>0.36</u>
FREEZING CYCLE TIME	70/21	<b>19</b>		20		21	
	80/27	20		21		23	
	90/32	20		<b>23</b>		24	
min.	100/38	20		23		25	
HARVEST CYCLE TIME	70/21	<b>4.0</b>		3.5		3.2	
	80/27	3.6		2.9		2.8	
	90/32	3.5		<b>2.4</b>		2.2	
min.	100/38	3.0		2.4		2.1	
HEAD PRESSURE	70/21	<b>217</b>	<u>15.3</u>	235	<u>16.6</u>	261	<u>18.4</u>
	80/27	231	<u>16.2</u>	260	<u>18.3</u>	286	<u>20.1</u>
	90/32	235	<u>16.6</u>	<b>280</b>	<u>19.7</u>	307	<u>21.6</u>
PSIG kg/cm2G	100/38	241	<u>16.9</u>	286	<u>20.1</u>	331	<u>23.3</u>
SUCTION PRESSURE	70/21	<b>36</b>	<u>2.5</u>	38	<u>2.7</u>	42	<u>2.9</u>
	80/27	37	<u>2.6</u>	40	<u>2.8</u>	45	<u>3.2</u>
	90/32	38	<u>2.7</u>	<b>42</b>	<u>3.0</u>	47	<u>3.3</u>
PSIG kg/cm2G	100/38	39	<u>2.8</u>	43	<u>3.0</u>	51	<u>3.6</u>

TOTAL HEAT OF REJECTION FROM CONDENSER 15,600 BTU/h [AT 90°F (32°C) / WT 70°F (21°C)]

### 13. KM-901MWH

#### Specification Sheet

AC SUPPLY VOLTAGE	208-230/60/1 (3 wire with neutral) or 208-230/60/1	
AMPERAGE	8.7A (5 Min. Freeze AT 104°F/WT 80°F)	
MINIMUM CIRCUIT AMPACITY	15 A	
MAXIMUM FUSE SIZE	15 A	
ELECTRIC & WATER CONSUMPTION	90/70°F	70/50°F
ELECTRIC W (kWH/100 lbs.)	1610(4.5)	1610(4.2)
WATER gal./24HR (gal./100 lbs.)	180(20.8)	239(25.8)
WATER COOLED CONDENSER gal./24HR (gal./100 lbs.)	1106(128)	610(66)
ICE PRODUCTION PER CYCLE	13.4 lbs. (6.1 kg) 720pcs.	
BIN CONTROL SYSTEM	Thermostat or Mechanical Bin Control	
REFRIGERANT CHARGE	R404A, 1 lb. 10.5 oz. (750g)	

#### Performance Data

APPROXIMATE ICE PRODUCTION PER 24 HR.	AMBIENT TEMP. (°F/°C)	WATER TEMP. (°F/°C)					
		50/10		70/21		90/32	
	70/21	<b>928</b>	<u>421</u>	909	<u>412</u>	857	<u>389</u>
	80/27	914	<u>414</u>	885	<u>401</u>	817	<u>371</u>
	90/32	909	<u>412</u>	<b>864</b>	<u>392</u>	802	<u>364</u>
lbs./day kg./day	100/38	890	<u>404</u>	849	<u>385</u>	745	<u>338</u>
APPROXIMATE ELECTRIC CONSUMPTION  watts	70/21	<b>1610</b>		1610		1626	
	80/27	1610		1610		1634	
	90/32	1610		<b>1610</b>		1631	
	100/38	1618		1615		1650	
APPROXIMATE WATER CONSUMPTION PER 24 HR.  gal./day m3/day	70/21	<b>849</b>	<u>3.21</u>	977	<u>3.70</u>	1453	<u>5.50</u>
	80/27	947	<u>3.58</u>	1145	<u>4.34</u>	1788	<u>6.77</u>
	90/32	977	<u>3.70</u>	<b>1286</b>	<u>4.87</u>	1868	<u>7.07</u>
	100/38	1298	<u>4.91</u>	1422	<u>5.38</u>	2403	<u>9.09</u>
FREEZING CYCLE TIME  min.	70/21	<b>19</b>		19		20	
	80/27	19		20		21	
	90/32	19		<b>21</b>		22	
	100/38	20		21		23	
HARVEST CYCLE TIME  min.	70/21	<b>4.1</b>		3.8		3.6	
	80/27	3.9		3.4		3.3	
	90/32	3.8		<b>3.1</b>		3.0	
	100/38	3.5		3.1		2.8	
HEAD PRESSURE  PSIG kg/cm2G	70/21	<b>239</b>	<u>16.8</u>	240	<u>16.9</u>	248	<u>17.5</u>
	80/27	240	<u>16.9</u>	242	<u>17.0</u>	254	<u>17.8</u>
	90/32	240	<u>16.9</u>	<b>243</b>	<u>17.1</u>	253	<u>17.8</u>
	100/38	244	<u>17.2</u>	245	<u>17.3</u>	263	<u>18.5</u>
SUCTION PRESSURE  PSIG kg/cm2G	70/21	<b>34</b>	<u>2.4</u>	35	<u>2.5</u>	37	<u>2.6</u>
	80/27	35	<u>2.4</u>	36	<u>2.5</u>	38	<u>2.7</u>
	90/32	35	<u>2.5</u>	<b>37</b>	<u>2.6</u>	39	<u>2.7</u>
	100/38	35	<u>2.5</u>	37	<u>2.6</u>	41	<u>2.9</u>

TOTAL HEAT OF REJECTION FROM CONDENSER	10,100 BTU/h [AT 90°F (32°C) / WT 70°F (21°C)]
TOTAL HEAT OF REJECTION FROM COMPRESSOR	1,700 BTU/h [AT 90°F (32°C) / WT 70°F (21°C)]
WATER FLOW FOR CONDENSER	94 gal./h [AT 100°F (38°C) / WT 90°F (32°C)]
PRESSURE DROP OF COOLING WATER LINE	less than 10 PSIG

## 14. KM-901MRH with URC-9F

### Specification Sheet

AC SUPPLY VOLTAGE	208-230/60/1 (3 wire with neutral) or 208-230/60/1	
AMPERAGE	11.6A (5 Min. Freeze AT 104°F/WT 80°F)	
MINIMUM CIRCUIT AMPACITY	20 A	
MAXIMUM FUSE SIZE	20 A	
ELECTRIC & WATER CONSUMPTION	90/70°F	70/50°F
ELECTRIC W (kWH/100 lbs.)	1770(5.4)	70/21(0.0)
WATER gal./24HR (gal./100 lbs.)	152(19.3)	10(0.0)
ICE PRODUCTION PER CYCLE	13.5 lbs. (6.1 kg) 720pcs.	
BIN CONTROL SYSTEM	Thermostat or Mechanical Bin Control	
TOTAL REFRIGERANT CHARGE	R404A, 9 lbs. 4 oz. (4200g)	
REFRIGERANT CHARGE BY UNIT	Icemaker 5 lbs. 5 oz. Cond. Unit 3 lbs. 15 oz.	

### Performance Data

APPROXIMATE ICE PRODUCTION PER 24 HR.	AMBIENT TEMP. (°F/°C)	WATER TEMP. (°F/°C)					
		50/10		70/21		90/32	
	70/21	<b>889</b>	<u>403</u>	859	<u>389</u>	803	<u>364</u>
	80/27	866	<u>393</u>	818	<u>371</u>	755	<u>343</u>
	90/32	859	<u>389</u>	<b>785</b>	<u>356</u>	724	<u>328</u>
lbs./day kg./day	100/38	843	<u>382</u>	771	<u>350</u>	668	<u>303</u>
APPROXIMATE ELECTRIC CONSUMPTION	70/21	<b>1590</b>		1643		1664	
	80/27	1630		1712		1705	
	90/32	1643		<b>1770</b>		1775	
watts	100/38	1630		1771		1780	
APPROXIMATE WATER CONSUMPTION PER 24 HR.	70/21	<b>246</b>	<u>0.93</u>	219	<u>0.83</u>	194	<u>0.74</u>
	80/27	225	<u>0.85</u>	182	<u>0.69</u>	165	<u>0.63</u>
	90/32	219	<u>0.83</u>	<b>152</b>	<u>0.57</u>	131	<u>0.50</u>
gal./day m3/day	100/38	182	<u>0.69</u>	147	<u>0.56</u>	112	<u>0.42</u>
FREEZING CYCLE TIME	70/21	<b>18</b>		20		21	
	80/27	19		21		23	
	90/32	20		<b>22</b>		24	
min.	100/38	20		23		26	
HARVEST CYCLE TIME	70/21	<b>4.3</b>		3.9		3.6	
	80/27	4.0		3.4		3.2	
	90/32	3.9		<b>2.9</b>		2.7	
min.	100/38	3.4		2.8		2.4	
HEAD PRESSURE	70/21	<b>208</b>	<u>14.6</u>	229	<u>16.1</u>	252	<u>17.7</u>
	80/27	224	<u>15.7</u>	256	<u>18.0</u>	277	<u>19.5</u>
	90/32	229	<u>16.1</u>	<b>279</b>	<u>19.6</u>	301	<u>21.2</u>
PSIG kg/cm2G	100/38	232	<u>16.3</u>	284	<u>20.0</u>	322	<u>22.6</u>
SUCTION PRESSURE	70/21	<b>35</b>	<u>2.5</u>	37	<u>2.6</u>	41	<u>2.9</u>
	80/27	37	<u>2.6</u>	40	<u>2.8</u>	45	<u>3.1</u>
	90/32	37	<u>2.6</u>	<b>43</b>	<u>3.0</u>	47	<u>3.3</u>
PSIG kg/cm2G	100/38	38	<u>2.7</u>	44	<u>3.1</u>	51	<u>3.6</u>
TOTAL HEAT OF REJECTION FROM CONDENSER	14,000 BTU/h [AT 90°F (32°C) / WT 70°F (21°C)]						
TOTAL HEAT OF REJECTION FROM COMPRESSOR	2,200 BTU/h [AT 90°F (32°C) / WT 70°F (21°C)]						
CONDENSER VOLUME	121 CU. IN (URC-9F)						

## 15. KM-901MRH3 with URC-9F

### Specification Sheet

AC SUPPLY VOLTAGE	208-230/60/3	
AMPERAGE	7.0A (5 Min. Freeze AT 104°F/WT 80°F)	
MINIMUM CIRCUIT AMPACITY	20 A	
MAXIMUM FUSE SIZE	20 A	
ELECTRIC & WATER CONSUMPTION	90/70°F	70/50°F
ELECTRIC W (kWH/100 lbs.)	1830(5.4)	1670(4.5)
WATER gal./24HR (gal./100 lbs.)	147(18.0)	254(28.2)
ICE PRODUCTION PER CYCLE	14.2 lbs. (6.4 kg) 720pcs.	
BIN CONTROL SYSTEM	Thermostat or Mechanical Bin Control	
TOTAL REFRIGERANT CHARGE	R404A, 9 lbs. 4 oz. (4200g)	
REFRIGERANT CHARGE BY UNIT	Icemaker 5 lbs. 5 oz. Cond. Unit 3 lbs. 15 oz.	

### Performance Data

APPROXIMATE ICE PRODUCTION PER 24 HR.	AMBIENT TEMP. (°F/°C)	WATER TEMP. (°F/°C)					
		50/10		70/21		90/32	
	70/21	<b>899</b>	<u>408</u>	874	<u>397</u>	817	<u>371</u>
	80/27	880	<u>399</u>	842	<u>382</u>	772	<u>350</u>
	90/32	874	<u>397</u>	<b>815</b>	<u>370</u>	749	<u>340</u>
lbs./day kg./day	100/38	855	<u>388</u>	800	<u>363</u>	689	<u>313</u>
APPROXIMATE ELECTRIC CONSUMPTION	70/21	<b>1670</b>		1717		1755	
	80/27	1706		1779		1803	
	90/32	1717		<b>1830</b>		1861	
watts	100/38	1716		1837		1890	
APPROXIMATE WATER CONSUMPTION PER 24 HR.	70/21	<b>254</b>	<u>0.96</u>	222	<u>0.84</u>	203	<u>0.77</u>
	80/27	230	<u>0.87</u>	181	<u>0.69</u>	174	<u>0.66</u>
	90/32	222	<u>0.84</u>	<b>147</b>	<u>0.56</u>	134	<u>0.51</u>
gal./day m3/day	100/38	185	<u>0.70</u>	144	<u>0.54</u>	123	<u>0.46</u>
FREEZING CYCLE TIME	70/21	<b>19</b>		20		21	
	80/27	20		21		23	
	90/32	20		<b>22</b>		24	
min.	100/38	20		23		26	
HARVEST CYCLE TIME	70/21	<b>4.4</b>		3.9		3.6	
	80/27	4.0		3.3		3.2	
	90/32	3.9		<b>2.8</b>		2.6	
min.	100/38	3.4		2.7		2.4	
HEAD PRESSURE	70/21	<b>206</b>	<u>14.5</u>	225	<u>15.8</u>	248	<u>17.5</u>
	80/27	220	<u>15.5</u>	249	<u>17.5</u>	272	<u>19.1</u>
	90/32	225	<u>15.8</u>	<b>270</b>	<u>19.0</u>	293	<u>20.6</u>
PSIG kg/cm2G	100/38	229	<u>16.1</u>	275	<u>19.4</u>	315	<u>22.1</u>
SUCTION PRESSURE	70/21	<b>36</b>	<u>2.5</u>	38	<u>2.7</u>	41	<u>2.9</u>
	80/27	37	<u>2.6</u>	40	<u>2.8</u>	44	<u>3.1</u>
	90/32	38	<u>2.7</u>	<b>42</b>	<u>3.0</u>	46	<u>3.2</u>
PSIG kg/cm2G	100/38	39	<u>2.7</u>	43	<u>3.0</u>	49	<u>3.4</u>

TOTAL HEAT OF REJECTION FROM CONDENSER	14,100 BTU/h [AT 90°F (32°C) / WT 70°F (21°C)]
TOTAL HEAT OF REJECTION FROM COMPRESSOR	2,200 BTU/h [AT 90°F (32°C) / WT 70°F (21°C)]
CONDENSER VOLUME	121 CU. IN (URC-9F)

## 16. KM-1100MAH

### Specification Sheet

AC SUPPLY VOLTAGE	208-230/60/1	
AMPERAGE	0A ( 5 Min. Freeze AT 104°F / WT 80°F)	
MINIMUM CIRCUIT AMPACITY	20 A	
MAXIMUM FUSE SIZE	20 A	
ELECTRIC & WATER CONSUMPTION	90/70°F	70/50°F
ELECTRIC W (kWH/100 lbs.)	2110(5.02)	1970(4.00)
WATER gal./24HR (gal./100 lbs.)	175(17.3)	391(33.0)
ICE PRODUCTION PER CYCLE	20.1 lbs. (9.1 kg) 960pcs.	
BIN CONTROL SYSTEM	Thermostat	
REFRIGERANT CHARGE	R404A, 3 lb. 15.5 oz. (1800g)	

### Performance Data

APPROXIMATE ICE PRODUCTION PER 24 HR.	AMBIENT TEMP. (°F/°C)	WATER TEMP. (°F/°C)					
		50/10		70/21		90/32	
	70/21	<b>1184</b>	<u>537</u>	1133	<u>514</u>	1058	<u>480</u>
	80/27	1145	<u>519</u>	1066	<u>484</u>	988	<u>448</u>
	90/32	1133	<u>514</u>	<b>1010</b>	<u>458</u>	931	<u>422</u>
lbs./day kg./day	100/38	1116	<u>506</u>	992	<u>450</u>	859	<u>390</u>
APPROXIMATE ELECTRIC CONSUMPTION	70/21	<b>1970</b>		2011		2048	
	80/27	2001		2065		2091	
	90/32	2011		<b>2110</b>		2141	
watts	100/38	2012		2117		2170	
APPROXIMATE WATER CONSUMPTION PER 24 HR.	70/21	<b>391</b>	<u>1.48</u>	327	<u>1.24</u>	290	<u>1.10</u>
	80/27	342	<u>1.30</u>	244	<u>0.92</u>	235	<u>0.89</u>
	90/32	327	<u>1.24</u>	<b>175</b>	<u>0.66</u>	153	<u>0.58</u>
gal./day m <sup>3</sup> /day	100/38	253	<u>0.96</u>	170	<u>0.64</u>	132	<u>0.50</u>
FREEZING CYCLE TIME	70/21	<b>21</b>		22		25	
	80/27	22		24		27	
	90/32	22		<b>25</b>		28	
min.	100/38	23		26		30	
HARVEST CYCLE TIME	70/21	<b>3.4</b>		3.0		2.9	
	80/27	3.1		2.4		2.6	
	90/32	3.0		<b>2.0</b>		2.0	
min.	100/38	2.6		2.0		2.0	
HEAD PRESSURE	70/21	<b>255</b>	<u>17.9</u>	274	<u>19.2</u>	300	<u>21.1</u>
	80/27	269	<u>18.9</u>	298	<u>21.0</u>	325	<u>22.9</u>
	90/32	274	<u>19.2</u>	<b>319</b>	<u>22.4</u>	346	<u>24.3</u>
PSIG kg/cm <sup>2</sup> G	100/38	279	<u>19.6</u>	325	<u>22.9</u>	371	<u>26.1</u>
SUCTION PRESSURE	70/21	<b>50</b>	<u>3.5</u>	52	<u>3.6</u>	55	<u>3.8</u>
	80/27	51	<u>3.6</u>	54	<u>3.8</u>	57	<u>4.0</u>
	90/32	52	<u>3.6</u>	<b>56</b>	<u>3.9</u>	59	<u>4.2</u>
PSIG kg/cm <sup>2</sup> G	100/38	53	<u>3.7</u>	57	<u>4.0</u>	62	<u>4.4</u>

TOTAL HEAT OF REJECTION FROM CONDENSER

0 BTU/h [AT 90°F (32°C) / WT 70°F (21°C)]

# 17. KM-1100MWH

## Specification Sheet

AC SUPPLY VOLTAGE	208-230/60/1	
AMPERAGE	9.6A (5 Min. Freeze AT 104°F / WT 80°F)	
MINIMUM CIRCUIT AMPACITY	20 A	
MAXIMUM FUSE SIZE	20 A	
ELECTRIC & WATER CONSUMPTION	90/70°F	70/50°F
ELECTRIC W (kWH/100 lbs.)	1710(3.81)	1620(3.50)
WATER gal./24HR (gal./100 lbs.)	182(16.9)	303(27.3)
CONDENSER WATER gal./24HR (gal./100 lbs.)	1362(126.6)	678(61.0)
ICE PRODUCTION PER CYCLE	19.7 lbs. (8.9 kg) 960pcs.	
BIN CONTROL SYSTEM	Thermostat	
REFRIGERANT CHARGE	R404A, 1 lb. 10.5 oz. (750g)	

## Performance Data

APPROXIMATE ICE PRODUCTION PER 24 HR.	AMBIENT TEMP. (°F/°C)	WATER TEMP. (°F/°C)					
		50/10		70/21		90/32	
	70/21	<b>1111</b>	<u>504</u>	1101	<u>499</u>	1038	<u>471</u>
	80/27	1103	<u>500</u>	1087	<u>493</u>	997	<u>452</u>
	90/32	1101	<u>499</u>	<b>1076</b>	<u>488</u>	996	<u>452</u>
lbs./day <u>kg./day</u>	100/38	1072	<u>486</u>	1057	<u>480</u>	923	<u>419</u>
APPROXIMATE ELECTRIC CONSUMPTION	70/21	<b>1620</b>		1646		1671	
	80/27	1640		1681		1699	
	90/32	1646		<b>1710</b>		1731	
watts	100/38	1647		1715		1750	
APPROXIMATE WATER CONSUMPTION PER 24 HR.	70/21	<b>981</b>	<u>3.71</u>	1146	<u>4.34</u>	1556	<u>5.89</u>
	80/27	1107	<u>4.19</u>	1363	<u>5.16</u>	1876	<u>7.10</u>
	90/32	1146	<u>4.34</u>	<b>1544</b>	<u>5.84</u>	2022	<u>7.66</u>
gal./day <u>m<sup>3</sup>/day</u>	100/38	1473	<u>5.58</u>	1656	<u>6.27</u>	2462	<u>9.32</u>
FREEZING CYCLE TIME	70/21	<b>23</b>		23		24	
	80/27	23		23		25	
	90/32	23		<b>24</b>		25	
min.	100/38	23		24		26	
HARVEST CYCLE TIME	70/21	<b>3.0</b>		2.7		2.7	
	80/27	2.8		2.4		2.5	
	90/32	2.7		<b>2.1</b>		2.1	
min.	100/38	2.5		2.1		2.1	
HEAD PRESSURE	70/21	<b>234</b>	<u>16.5</u>	236	<u>16.6</u>	246	<u>17.3</u>
	80/27	236	<u>16.6</u>	239	<u>16.8</u>	253	<u>17.8</u>
	90/32	236	<u>16.6</u>	<b>241</b>	<u>16.9</u>	254	<u>17.9</u>
PSIG <u>kg/cm<sup>2</sup>G</u>	100/38	241	<u>16.9</u>	244	<u>17.2</u>	266	<u>18.7</u>
SUCTION PRESSURE	70/21	<b>51</b>	<u>3.6</u>	51	<u>3.6</u>	54	<u>3.8</u>
	80/27	51	<u>3.6</u>	51	<u>3.6</u>	55	<u>3.9</u>
	90/32	51	<u>3.6</u>	<b>51</b>	<u>3.6</u>	55	<u>3.8</u>
PSIG <u>kg/cm<sup>2</sup>G</u>	100/38	52	<u>3.7</u>	52	<u>3.6</u>	58	<u>4.1</u>

TOTAL HEAT OF REJECTION FROM CONDENSER 17900 BTU/h [AT 90°F (32°C) / WT 70°F (21°C)]

TOTAL HEAT OF REJECTION FROM COMPRESSOR 2100 BTU/h [AT 90°F (32°C) / WT 70°F (21°C)]

WATER FLOW FOR CONDENSER 96.14583333 gal./h [AT 100°F (38°C) / WT 90°F (32°C)]

PRESSURE DROP OF COOLING WATER Less than 10 PSIG

## 18. KM-1100MRH

### Specification Sheet

AC SUPPLY VOLTAGE	208-230/60/1	
AMPERAGE	12.5A ( 5 Min. Freeze AT 104°F / WT 80°F)	
MINIMUM CIRCUIT AMPACITY	20 A	
MAXIMUM FUSE SIZE	20 A	
ELECTRIC & WATER CONSUMPTION	90/70°F	70/50°F
ELECTRIC W (kWH/100 lbs.)	1990(4.66)	1830(3.71)
WATER gal./24HR (gal./100 lbs.)	168(16.4)	355(30.0)
ICE PRODUCTION PER CYCLE	20.1 lbs. (9.1 kg) 960pcs.	
BIN CONTROL SYSTEM	Thermostat	
TOTAL REFRIGERANT CHARGE	R404A, 9 lb. 11.2 oz. (4400g) Icemaker, 5 lb. 4.7 oz. (2400g), Condenser, 4 lb. 6.5 oz. (2000g)	

### Performance Sheet

APPROXIMATE ICE PRODUCTION PER 24 HR.	AMBIENT TEMP. (°F/°C)	WATER TEMP. (°F/°C)					
		50/10		70/21		90/32	
	70/21	<b>1183</b>	<u>537</u>	1137	<u>516</u>	1062	<u>482</u>
	80/27	1148	<u>521</u>	1077	<u>489</u>	995	<u>451</u>
	90/32	1137	<u>516</u>	<b>1027</b>	<u>466</u>	946	<u>429</u>
lbs./day <u>kg./day</u>	100/38	1118	<u>507</u>	1008	<u>457</u>	872	<u>396</u>
APPROXIMATE ELECTRIC CONSUMPTION	70/21	<b>1830</b>		1877		1904	
	80/27	1866		1939		1945	
	90/32	1877		<b>1990</b>		2006	
watts	100/38	1870		1994		2020	
APPROXIMATE WATER CONSUMPTION PER 24 HR.	70/21	<b>355</b>	<u>1.34</u>	300	<u>1.14</u>	269	<u>1.02</u>
	80/27	313	<u>1.19</u>	228	<u>0.86</u>	221	<u>0.84</u>
	90/32	300	<u>1.14</u>	<b>168</b>	<u>0.64</u>	150	<u>0.57</u>
gal./day <u>m<sup>3</sup>/day</u>	100/38	236	<u>0.89</u>	164	<u>0.62</u>	133	<u>0.50</u>
FREEZING CYCLE TIME	70/21	<b>21</b>		22		24	
	80/27	22		24		26	
	90/32	22		<b>25</b>		27	
min.	100/38	23		26		30	
HARVEST CYCLE TIME	70/21	<b>3.4</b>		3.0		2.9	
	80/27	3.1		2.4		2.6	
	90/32	3.0		<b>2.0</b>		2.0	
min.	100/38	2.6		2.0		2.0	
HEAD PRESSURE	70/21	<b>208</b>	<u>14.6</u>	224	<u>15.8</u>	244	<u>17.2</u>
	80/27	221	<u>15.5</u>	246	<u>17.3</u>	264	<u>18.6</u>
	90/32	224	<u>15.8</u>	<b>264</b>	<u>18.6</u>	283	<u>19.9</u>
PSIG <u>kg/cm<sup>2</sup>G</u>	100/38	227	<u>16.0</u>	269	<u>18.9</u>	301	<u>21.2</u>
SUCTION PRESSURE	70/21	<b>49</b>	<u>3.4</u>	51	<u>3.6</u>	55	<u>3.9</u>
	80/27	51	<u>3.6</u>	54	<u>3.8</u>	58	<u>4.1</u>
	90/32	51	<u>3.6</u>	<b>56</b>	<u>3.9</u>	60	<u>4.2</u>
PSIG <u>kg/cm<sup>2</sup>G</u>	100/38	52	<u>3.7</u>	57	<u>4.0</u>	64	<u>4.5</u>
TOTAL HEAT OF REJECTION FROM CONDENSER	19,200 BTU/h [AT 90°F (32°C) / WT 70°F (21°C)]						
TOTAL HEAT OF REJECTION FROM COMPRESSOR	2,200 BTU/h [AT 90°F (32°C) / WT 70°F (21°C)]						
CONDENSER VOLUME	133 IN3 (URC-14F)						

## 19. KM-1340MAH

### Specification Sheet

AC SUPPLY VOLTAGE	208-230/60/1 (3 Wire with neutral)	
AMPERAGE	13.2 A ( 5 Min. Freeze AT 104°F / WT 80°F)	
MINIMUM CIRCUIT AMPACITY	20 A	
MAXIMUM FUSE SIZE	20 A	
ELECTRIC & WATER CONSUMPTION	90/70°F	70/50°F
ELECTRIC W (kWH/100 lbs.)	2280(4.7)	2100(3.8)
WATER gal./24HR (gal./100 lbs.)	214(18.3)	413(31.2)
ICE PRODUCTION PER CYCLE	28.1 lbs. (12.7 kg) 1440 pcs.	
BIN CONTROL SYSTEM	Thermostat	
REFRIGERANT CHARGE	R-404A, 4 lb. 11.4 oz. (2140g)	

### Performance Data

APPROXIMATE ICE PRODUCTION PER 24 HR.	AMBIENT TEMP. (°F/°C)	WATER TEMP. (°F/°C)					
		50/10		70/21		90/32	
	70/21	<b>1325</b>	<u>601</u>	1278	<u>580</u>	1200	<u>544</u>
	80/27	1289	<u>585</u>	1218	<u>552</u>	1130	<u>513</u>
	90/32	1278	<u>580</u>	<b>1167</b>	<u>529</u>	1081	<u>491</u>
lbs./day kg./day	100/38	1257	<u>570</u>	1147	<u>520</u>	1003	<u>455</u>
APPROXIMATE ELECTRIC CONSUMPTION	70/21	<b>2100</b>		2153		2197	
	80/27	2140		2222		2251	
	90/32	2153		<b>2280</b>		2316	
watts	100/38	2152		2289		2350	
APPROXIMATE WATER CONSUMPTION PER 24 HR.	70/21	<b>413</b>	<u>1.56</u>	355	<u>1.34</u>	306	<u>1.16</u>
	80/27	369	<u>1.40</u>	278	<u>1.05</u>	246	<u>0.93</u>
	90/32	355	<u>1.34</u>	<b>214</b>	<u>0.81</u>	174	<u>0.66</u>
gal./day m3/day	100/38	280	<u>1.06</u>	204	<u>0.77</u>	137	<u>0.52</u>
FREEZING CYCLE TIME	70/21	<b>27</b>		29		31	
	80/27	28		31		34	
	90/32	29		<b>33</b>		36	
min.	100/38	29		33		38	
HARVEST CYCLE TIME	70/21	<b>4.9</b>		4.3		3.8	
	80/27	4.4		3.4		3.2	
	90/32	4.3		<b>2.7</b>		2.3	
min.	100/38	3.4		2.6		2.0	
HEAD PRESSURE	70/21	<b>251</b>	<u>17.6</u>	272	<u>19.1</u>	293	<u>20.6</u>
	80/27	267	<u>18.8</u>	299	<u>21.0</u>	316	<u>22.2</u>
	90/32	272	<u>19.1</u>	<b>322</b>	<u>22.6</u>	341	<u>24.0</u>
PSIG kg/cm2G	100/38	274	<u>19.2</u>	327	<u>23.0</u>	359	<u>25.2</u>
SUCTION PRESSURE	70/21	<b>45</b>	<u>3.2</u>	48	<u>3.4</u>	50	<u>3.5</u>
	80/27	48	<u>3.4</u>	52	<u>3.7</u>	53	<u>3.7</u>
	90/32	48	<u>3.4</u>	<b>56</b>	<u>3.9</u>	57	<u>4.0</u>
PSIG kg/cm2G	100/38	48	<u>3.4</u>	56	<u>3.9</u>	58	<u>4.1</u>

TOTAL HEAT OF REJECTION FROM CONDENSER

22,600 BTU/h [AT 90°F (32°C) / WT 70°F (21°C)]

## 20. KM-1340MWH

### Specification Sheet

AC SUPPLY VOLTAGE	208-230/60/1 (3 Wire with neutral)	
AMPERAGE	10.7A ( 5 Min. Freeze AT 104°F / WT 80°F)	
MINIMUM CIRCUIT AMPACITY	20 A	
MAXIMUM FUSE SIZE	20 A	
ELECTRIC & WATER CONSUMPTION	90/70°F	70/50°F
ELECTRIC W (kWH/100 lbs.)	2140(3.90)	2040(3.68)
WATER gal./24HR (gal./100 lbs.)	259(19.7)	417(31.4)
WATER COOLED CONDENSER	1748(133)	880(66)
	gal./24HR (gal./100 lbs.)	
ICE PRODUCTION PER CYCLE	28.1 lbs. (12.7 kg) 1440 pcs.	
BIN CONTROL SYSTEM	Thermostat	
REFRIGERANT CHARGE	R-404A, 2 lb. 1.5 oz. (950g)	

### Performance Data

APPROXIMATE ICE PRODUCTION PER 24 HR.	AMBIENT TEMP. (°F/°C)	WATER TEMP. (°F/°C)					
		50/10		70/21		90/32	
	70/21	<b>1329</b>	<u>603</u>	1325	<u>601</u>	1247	<u>566</u>
	80/27	1326	<u>602</u>	1320	<u>599</u>	1201	<u>545</u>
	90/32	1325	<u>601</u>	<b>1316</b>	<u>597</u>	1213	<u>550</u>
lbs./day kg./day	100/38	1285	<u>583</u>	1292	<u>586</u>	1118	<u>507</u>
APPROXIMATE ELECTRIC CONSUMPTION	70/21	<b>2040</b>		2069		2079	
	80/27	2062		2108		2100	
	90/32	2069		<b>2140</b>		2140	
watts	100/38	2061		2140		2140	
APPROXIMATE WATER CONSUMPTION PER 24 HR.	70/21	<b>1297</b>	<u>4.91</u>	1505	<u>5.70</u>	1951	<u>7.38</u>
	80/27	1456	<u>5.51</u>	1779	<u>6.73</u>	2314	<u>8.76</u>
	90/32	1505	<u>5.70</u>	<b>2007</b>	<u>7.60</u>	2514	<u>9.52</u>
gal./day m3/day	100/38	1887	<u>7.14</u>	2126	<u>8.05</u>	2979	<u>11.28</u>
FREEZING CYCLE TIME	70/21	<b>26</b>		27		29	
	80/27	27		28		30	
	90/32	27		<b>29</b>		31	
min.	100/38	27		29		33	
HARVEST CYCLE TIME	70/21	<b>4.9</b>		4.4		4.0	
	80/27	4.5		3.7		3.5	
	90/32	4.4		<b>3.1</b>		2.8	
min.	100/38	3.7		3.0		2.5	
HEAD PRESSURE	70/21	<b>234</b>	<u>16.5</u>	237	<u>16.6</u>	251	<u>17.6</u>
	80/27	236	<u>16.6</u>	240	<u>16.9</u>	260	<u>18.3</u>
	90/32	237	<u>16.6</u>	<b>243</b>	<u>17.1</u>	261	<u>18.4</u>
PSIG kg/cm2G	100/38	243	<u>17.1</u>	247	<u>17.4</u>	278	<u>19.5</u>
SUCTION PRESSURE	70/21	<b>42</b>	<u>3.0</u>	43	<u>3.0</u>	45	<u>3.1</u>
	80/27	43	<u>3.0</u>	44	<u>3.1</u>	46	<u>3.3</u>
	90/32	43	<u>3.0</u>	<b>45</b>	<u>3.1</u>	47	<u>3.3</u>
PSIG kg/cm2G	100/38	44	<u>3.1</u>	45	<u>3.2</u>	49	<u>3.5</u>

TOTAL HEAT OF REJECTION FROM CONDENSER 18,800 BTU/h [AT 90°F (32°C) / WT 70°F (21°C)]

TOTAL HEAT OF REJECTION FROM COMPRESSOR 2,700 BTU/h [AT 90°F (32°C) / WT 70°F (21°C)]

WATER FLOW FOR CONDENSER 116 gal./h [AT 100°F (38°C) / WT 90°F (32°C)]

PRESSURE DROP OF COOLING WATER LINE less than 10 PSIG

## 21. KM-1340MRH with URC-14F

### Specification Sheet

AC SUPPLY VOLTAGE	208-230/60/1 (3 wire with neutral)	
AMPERAGE	13.4 A ( 5 Min. Freeze AT 104°F / WT 80°F)	
MINIMUM CIRCUIT AMPACITY	20 A	
MAXIMUM FUSE SIZE	20 A	
ELECTRIC & WATER CONSUMPTION	90/70°F	70/50°F
ELECTRIC W (kWH/100 lbs.)	2360(4.5)	2130(3.7)
WATER gal./24HR (gal./100 lbs.)	229(18.3)	451(32.2)
ICE PRODUCTION PER CYCLE	28.7 lbs. (13.0 kg) 1440 pcs.	
BIN CONTROL SYSTEM	Thermostat	
TOTAL REFRIGERANT CHARGE	R-404A, 9 lb. 14.7 oz. (4,500g)	
REFRIGERANT CHARGE by UNIT	Icemaker 5 lbs. 8.2 oz. Cond. Unit 4 lb. 6.5 oz.	

### Performance Data

APPROXIMATE ICE PRODUCTION PER 24 HR.	AMBIENT TEMP. (°F/°C)	WATER TEMP. (°F/°C)					
		50/10		70/21		90/32	
	70/21	<b>1401</b>	<u>635</u>	1357	<u>615</u>	1274	<u>578</u>
	80/27	1367	<u>620</u>	1299	<u>589</u>	1204	<u>546</u>
	90/32	1357	<u>615</u>	<b>1251</b>	<u>567</u>	1159	<u>526</u>
lbs./day kg./day	100/38	1333	<u>604</u>	1229	<u>558</u>	1075	<u>488</u>
APPROXIMATE ELECTRIC CONSUMPTION  watts	70/21	<b>2130</b>		2197		2231	
	80/27	2181		2286		2287	
	90/32	2197		<b>2360</b>		2376	
	100/38	2184		2364		2390	
APPROXIMATE WATER CONSUMPTION PER 24 HR.  gal./day m3/day	70/21	<b>451</b>	<u>1.71</u>	386	<u>1.46</u>	344	<u>1.30</u>
	80/27	401	<u>1.52</u>	300	<u>1.14</u>	284	<u>1.08</u>
	90/32	386	<u>1.46</u>	<b>229</b>	<u>0.87</u>	201	<u>0.76</u>
	100/38	308	<u>1.16</u>	222	<u>0.84</u>	175	<u>0.66</u>
FREEZING CYCLE TIME  min.	70/21	<b>25</b>		27		29	
	80/27	26		29		31	
	90/32	27		<b>31</b>		33	
	100/38	27		31		35	
HARVEST CYCLE TIME  min.	70/21	<b>5.5</b>		4.8		4.3	
	80/27	5.0		3.9		3.6	
	90/32	4.8		<b>3.2</b>		2.8	
	100/38	4.0		3.1		2.4	
HEAD PRESSURE  PSIG kg/cm2G	70/21	<b>208</b>	<u>14.6</u>	226	<u>15.9</u>	247	<u>17.4</u>
	80/27	221	<u>15.6</u>	250	<u>17.6</u>	269	<u>18.9</u>
	90/32	226	<u>15.9</u>	<b>270</b>	<u>19.0</u>	290	<u>20.4</u>
	100/38	229	<u>16.1</u>	275	<u>19.3</u>	309	<u>21.7</u>
SUCTION PRESSURE  PSIG kg/cm2G	70/21	<b>44</b>	<u>3.1</u>	47	<u>3.3</u>	49	<u>3.4</u>
	80/27	46	<u>3.2</u>	50	<u>3.5</u>	51	<u>3.6</u>
	90/32	47	<u>3.3</u>	<b>53</b>	<u>3.7</u>	54	<u>3.8</u>
	100/38	47	<u>3.3</u>	53	<u>3.7</u>	55	<u>3.9</u>

TOTAL HEAT OF REJECTION FROM CONDENSER	20,800 BTU/h [AT 90°F (32°C) / WT 70°F (21°C)]
TOTAL HEAT OF REJECTION FROM COMPRESSOR	3,000 BTU/h [AT 90°F (32°C) / WT 70°F (21°C)]
CONDENSER VOLUME	134 CU. IN (URC-14F)

## 22. KM-1340MRH3 with URC-14F

### Specification Sheet

AC SUPPLY VOLTAGE	208-230/60/3	
AMPERAGE	9 A ( 5 Min. Freeze AT 104°F / WT 80°F)	
MINIMUM CIRCUIT AMPACITY	20 A	
MAXIMUM FUSE SIZE	20 A	
ELECTRIC & WATER CONSUMPTION	90/70°F	70/50°F
ELECTRIC W (kWH/100 lbs.)	2350(4.75)	2170(3.82)
WATER gal./24HR (gal./100 lbs.)	255(21.5)	491(36.0)
ICE PRODUCTION PER CYCLE	28.7 lbs. (13.0 kg) 1440 pcs.	
BIN CONTROL SYSTEM	Thermostat	
REFRIGERANT CHARGE	R-404A, 9 lb. 14.7 oz. (4,500g)	
	(Icemaker 5 lbs. 8.2 oz. Cond. Unit 4 lb. 6.5 oz.)	

### Performance Data

APPROXIMATE ICE PRODUCTION PER 24 HR.	AMBIENT TEMP. (°F/°C)	WATER TEMP. (°F/°C)					
		50/10		70/21		90/32	
	70/21	<b>1364</b>	<u>619</u>	1312	<u>595</u>	1216	<u>551</u>
	80/27	1324	<u>601</u>	1243	<u>564</u>	1133	<u>514</u>
	90/32	1312	<u>595</u>	<b>1185</b>	<u>538</u>	1079	<u>490</u>
lbs./day kg./day	100/38	1284	<u>583</u>	1160	<u>526</u>	982	<u>445</u>
APPROXIMATE ELECTRIC CONSUMPTION	70/21	<b>2170</b>		2223		2275	
	80/27	2210		2292		2333	
	90/32	2223		<b>2350</b>		2397	
watts	100/38	2226		2361		2440	
APPROXIMATE WATER CONSUMPTION PER 24 HR.	70/21	<b>491</b>	<u>1.86</u>	422	<u>1.60</u>	371	<u>1.41</u>
	80/27	438	<u>1.66</u>	331	<u>1.25</u>	305	<u>1.15</u>
	90/32	422	<u>1.60</u>	<b>255</b>	<u>0.96</u>	217	<u>0.82</u>
gal./day m <sup>3</sup> /day	100/38	336	<u>1.27</u>	246	<u>0.93</u>	183	<u>0.69</u>
FREEZING CYCLE TIME	70/21	<b>24</b>		26		28	
	80/27	25		28		31	
	90/32	26		<b>30</b>		33	
min.	100/38	26		31		35	
HARVEST CYCLE TIME	70/21	<b>5.1</b>		4.5		4.1	
	80/27	4.7		3.7		3.5	
	90/32	4.5		<b>3.0</b>		2.7	
min.	100/38	3.8	#VALUE!	3.0	3.0	2.4	
HEAD PRESSURE	70/21	<b>208</b>	<u>14.6</u>	226	<u>15.9</u>	252	<u>17.7</u>
	80/27	222	<u>15.6</u>	248	<u>17.5</u>	276	<u>19.4</u>
	90/32	226	<u>15.9</u>	<b>267</b>	<u>18.8</u>	295	<u>20.7</u>
PSIG kg/cm <sup>2</sup> G	100/38	232	<u>16.3</u>	274	<u>19.2</u>	320	<u>22.5</u>
SUCTION PRESSURE	70/21	<b>45</b>	<u>3.2</u>	46	<u>3.2</u>	51	<u>3.6</u>
	80/27	46	<u>3.2</u>	47	<u>3.3</u>	54	<u>3.8</u>
	90/32	46	<u>3.2</u>	<b>48</b>	<u>3.4</u>	54	<u>3.8</u>
PSIG kg/cm <sup>2</sup> G	100/38	48	<u>3.4</u>	50	<u>3.5</u>	60	<u>4.2</u>

TOTAL HEAT OF REJECTION FROM CONDENSER 21,800 BTU/h [AT 90°F (32°C) / WT 70°F (21°C)]

TOTAL HEAT OF REJECTION FROM COMPRESSOR 3,000 BTU/h [AT 90°F (32°C) / WT 70°F (21°C)]

CONDENSER VOLUME 134 CU. IN (URC-14F)

### 23. KM-1601MRH with URC-21F

#### Specification Sheet

AC SUPPLY VOLTAGE	208-230/60/1 (3 wire with neutral)	
AMPERAGE	11.6 A ( 5 Min. Freeze AT 104°F / WT 80°F)	
MINIMUM CIRCUIT AMPACITY	20 A	
MAXIMUM FUSE SIZE	20 A	
ELECTRIC & WATER CONSUMPTION	90/70°F	70/50°F
ELECTRIC W (kWH/100 lbs.)	2670(4.5)	2450(3.9)
WATER gal./24HR (gal./100 lbs.)	263(18.5)	483(32.0)
ICE PRODUCTION PER CYCLE	29.8 lbs. (13.5 kg) 1440 pcs.	
BIN CONTROL SYSTEM	Thermostat	
TOTAL REFRIGERANT CHARGE	R-404A, 24 lb. 4.0 oz. (11,000g)	
REFRIGERANT CHARGE by UNIT	Icemaker 14 lbs. 8.8 oz. Cond. Unit 9 lb. 11.2 oz.	

#### Performance Data

APPROXIMATE ICE PRODUCTION PER 24 HR.	AMBIENT TEMP. (°F/°C)	WATER TEMP. (°F/°C)					
		50/10		70/21		90/32	
	70/21	<b>1508</b>	<u>684</u>	1483	<u>673</u>	1399	<u>634</u>
	80/27	1489	<u>675</u>	1450	<u>658</u>	1338	<u>607</u>
	90/32	1483	<u>673</u>	<b>1422</b>	<u>645</u>	1320	<u>599</u>
lbs./day kg./day	100/38	1449	<u>657</u>	1398	<u>634</u>	1227	<u>557</u>
APPROXIMATE ELECTRIC CONSUMPTION	70/21	<b>2450</b>		2514		2532	
	80/27	2499		2599		2577	
	90/32	2514		<b>2670</b>		2665	
watts	100/38	2494		2669		2660	
APPROXIMATE WATER CONSUMPTION PER 24 HR.	70/21	<b>483</b>	<u>1.83</u>	418	<u>1.58</u>	363	<u>1.37</u>
	80/27	434	<u>1.64</u>	334	<u>1.26</u>	296	<u>1.12</u>
	90/32	418	<u>1.58</u>	<b>263</b>	<u>1.00</u>	217	<u>0.82</u>
gal./day m3/day	100/38	335	<u>1.27</u>	252	<u>0.95</u>	174	<u>0.66</u>
FREEZING CYCLE TIME	70/21	<b>23</b>		24		26	
	80/27	24		25		27	
	90/32	24		<b>27</b>		28	
min.	100/38	24		27		30	
HARVEST CYCLE TIME	70/21	<b>5.3</b>		4.6		4.1	
	80/27	4.8		3.6		3.4	
	90/32	4.6		<b>2.8</b>		2.5	
min.	100/38	3.7		2.8		2.2	
HEAD PRESSURE	70/21	<b>200</b>	<u>14.1</u>	215	<u>15.1</u>	231	<u>16.3</u>
	80/27	211	<u>14.9</u>	234	<u>16.5</u>	249	<u>17.5</u>
	90/32	215	<u>15.1</u>	<b>251</b>	<u>17.6</u>	266	<u>18.7</u>
PSIG kg/cm2G	100/38	217	<u>15.3</u>	254	<u>17.9</u>	281	<u>19.8</u>
SUCTION PRESSURE	70/21	<b>35</b>	<u>2.5</u>	37	<u>2.6</u>	39	<u>2.7</u>
	80/27	36	<u>2.6</u>	39	<u>2.7</u>	41	<u>2.9</u>
	90/32	37	<u>2.6</u>	<b>41</b>	<u>2.9</u>	43	<u>3.0</u>
PSIG kg/cm2G	100/38	37	<u>2.6</u>	41	<u>2.9</u>	45	<u>3.2</u>

TOTAL HEAT OF REJECTION FROM CONDENSER 23,400 BTU/h [AT 90°F (32°C) / WT 70°F (21°C)]

TOTAL HEAT OF REJECTION FROM COMPRESSOR 3,200 BTU/h [AT 90°F (32°C) / WT 70°F (21°C)]

CONDENSER VOLUME 441 CU. IN (URC-21F)

## 24. KM-1601MRH with URC-22F

### Specification Sheet

AC SUPPLY VOLTAGE	208-230/60/1 (3 wire with neutral)	
AMPERAGE	11.6 A ( 5 Min. Freeze AT 104°F / WT 80°F)	
MINIMUM CIRCUIT AMPACITY	20 A	
MAXIMUM FUSE SIZE	20 A	
ELECTRIC & WATER CONSUMPTION	90/70°F	70/50°F
ELECTRIC W (kWH/100 lbs.)	2740(4.64)	2590(4.17)
WATER gal./24HR (gal./100 lbs.)	264(18.6)	521(34.9)
ICE PRODUCTION PER CYCLE	27.9 lbs. (12.7 kg) 1440 pcs.	
BIN CONTROL SYSTEM	Thermostat	
REFRIGERANT CHARGE (w/URC-22F)	R-404A, 22 lb. 4.3 oz. (10,100g) (Icemaker 14 lbs. 8.8 oz. Cond. Unit 9 lb. 11.2 oz.)	

### Performance Data

APPROXIMATE ICE PRODUCTION PER 24 HR.	AMBIENT TEMP. (°F/°C)	WATER TEMP. (°F/°C)					
		50/10		70/21		90/32	
	70/21	<b>1493</b>	<u>677</u>	1471	<u>667</u>	1410	<u>640</u>
	80/27	1476	<u>670</u>	1441	<u>654</u>	1364	<u>619</u>
	90/32	1471	<u>667</u>	<b>1417</b>	<u>643</u>	1346	<u>610</u>
lbs./day kg./day	100/38	1449	<u>657</u>	1400	<u>635</u>	1280	<u>581</u>
APPROXIMATE ELECTRIC CONSUMPTION	70/21	<b>2590</b>		2634		2687	
	80/27	2623		2692		2741	
	90/32	2634		<b>2740</b>		2792	
watts	100/38	2642		2752		2840	
APPROXIMATE WATER CONSUMPTION PER 24 HR.	70/21	<b>521</b>	<u>1.97</u>	446	<u>1.69</u>	396	<u>1.50</u>
	80/27	464	<u>1.75</u>	346	<u>1.31</u>	327	<u>1.24</u>
	90/32	446	<u>1.69</u>	<b>264</b>	<u>1.00</u>	230	<u>0.87</u>
gal./day m <sup>3</sup> /day	100/38	355	<u>1.34</u>	256	<u>0.97</u>	200	<u>0.76</u>
FREEZING CYCLE TIME	70/21	<b>22</b>		24		25	
	80/27	23		25		27	
	90/32	24		<b>26</b>		28	
min.	100/38	24		27		30	
HARVEST CYCLE TIME	70/21	<b>5.4</b>		4.7		4.2	
	80/27	4.8		3.8		3.5	
	90/32	4.7		<b>3.0</b>		2.6	
min.	100/38	3.8		2.9		2.2	
HEAD PRESSURE	70/21	<b>205</b>	<u>14.4</u>	218	<u>15.3</u>	233	<u>16.4</u>
	80/27	215	<u>15.1</u>	236	<u>16.6</u>	249	<u>17.5</u>
	90/32	218	<u>15.3</u>	<b>250</b>	<u>17.6</u>	265	<u>18.6</u>
PSIG kg/cm <sup>2</sup> G	100/38	220	<u>15.5</u>	254	<u>17.8</u>	279	<u>19.6</u>
SUCTION PRESSURE	70/21	<b>38</b>	<u>2.7</u>	40	<u>2.8</u>	42	<u>3.0</u>
	80/27	39	<u>2.8</u>	42	<u>2.9</u>	44	<u>3.1</u>
	90/32	40	<u>2.8</u>	<b>43</b>	<u>3.1</u>	46	<u>3.2</u>
PSIG kg/cm <sup>2</sup> G	100/38	40	<u>2.8</u>	44	<u>3.1</u>	48	<u>3.4</u>

TOTAL HEAT OF REJECTION FROM CONDENSER 27,400 BTU/h [AT 90°F (32°C) / WT 70°F (21°C)]

TOTAL HEAT OF REJECTION FROM COMPRESSOR 3,200 BTU/h [AT 90°F (32°C) / WT 70°F (21°C)]

CONDENSER VOLUME 214 CU. IN. (URC-22F)

## 25. KM-1601MRH3 with URC-21F

### Specification Sheet

AC SUPPLY VOLTAGE	208-230/60/3	
AMPERAGE	8.4 A ( 5 Min. Freeze AT 104°F / WT 80°F)	
MINIMUM CIRCUIT AMPACITY	20 A	
MAXIMUM FUSE SIZE	20 A	
ELECTRIC & WATER CONSUMPTION	90/70°F	70/50°F
ELECTRIC W (kWH/100 lbs.)	2640(4.6)	2410(3.9)
WATER gal./24HR (gal./100 lbs.)	267(19.2)	491(33.4)
ICE PRODUCTION PER CYCLE	28.0 lbs. (12.7 kg) 1440 pcs.	
BIN CONTROL SYSTEM	Thermostat	
TOTAL REFRIGERANT CHARGE	R-404A, 24 lb. 4.0 oz. (11,000g)	
REFRIGERANT CHARGE by UNIT	Icemaker 14 lbs. 8.8 oz. Cond. Unit 9 lb. 11.2 oz.	

### Performance Data

APPROXIMATE ICE PRODUCTION PER 24 HR.	AMBIENT TEMP. (°F/°C)	WATER TEMP. (°F/°C)					
		50/10		70/21		90/32	
	70/21	<b>1471</b>	<u>667</u>	1448	<u>657</u>	1354	<u>614</u>
	80/27	1453	<u>659</u>	1417	<u>643</u>	1290	<u>585</u>
	90/32	1448	<u>657</u>	<b>1392</b>	<u>631</u>	1277	<u>579</u>
lbs./day kg./day	100/38	1408	<u>639</u>	1365	<u>619</u>	1171	<u>531</u>
APPROXIMATE ELECTRIC CONSUMPTION	70/21	<b>2410</b>		2477		2503	
	80/27	2461		2566		2555	
	90/32	2477		<b>2640</b>		2645	
watts	100/38	2460		2641		2650	
APPROXIMATE WATER CONSUMPTION PER 24 HR.	70/21	<b>491</b>	<u>1.86</u>	426	<u>1.61</u>	368	<u>1.39</u>
	80/27	441	<u>1.67</u>	339	<u>1.28</u>	299	<u>1.13</u>
	90/32	426	<u>1.61</u>	<b>267</b>	<u>1.01</u>	218	<u>0.83</u>
gal./day m3/day	100/38	340	<u>1.29</u>	256	<u>0.97</u>	173	<u>0.66</u>
FREEZING CYCLE TIME	70/21	<b>23</b>		24		26	
	80/27	23		25		27	
	90/32	24		<b>27</b>		29	
min.	100/38	24		27		31	
HARVEST CYCLE TIME	70/21	<b>5.7</b>		4.9		4.4	
	80/27	5.1		3.9		3.6	
	90/32	4.9		<b>3.1</b>		2.7	
min.	100/38	4.0		3.0		2.3	
HEAD PRESSURE	70/21	<b>203</b>	<u>14.3</u>	218	<u>15.3</u>	242	<u>17.0</u>
	80/27	214	<u>15.1</u>	237	<u>16.7</u>	263	<u>18.5</u>
	90/32	218	<u>15.3</u>	<b>253</b>	<u>17.8</u>	279	<u>19.6</u>
PSIG kg/cm2G	100/38	224	<u>15.7</u>	259	<u>18.2</u>	303	<u>21.3</u>
SUCTION PRESSURE	70/21	<b>38</b>	<u>2.7</u>	40	<u>2.8</u>	42	<u>2.9</u>
	80/27	40	<u>2.8</u>	43	<u>3.0</u>	44	<u>3.1</u>
	90/32	40	<u>2.8</u>	<b>45</b>	<u>3.2</u>	47	<u>3.3</u>
PSIG kg/cm2G	100/38	40	<u>2.8</u>	45	<u>3.2</u>	48	<u>3.4</u>

TOTAL HEAT OF REJECTION FROM CONDENSER	24,900 BTU/h [AT 90°F (32°C) / WT 70°F (21°C)]
TOTAL HEAT OF REJECTION FROM COMPRESSOR	3,200 BTU/h [AT 90°F (32°C) / WT 70°F (21°C)]
CONDENSER VOLUME	441 CU. IN (URC-21F)

## 26. KM-1601MRH3 with URC-22F

### Specification Sheet

AC SUPPLY VOLTAGE	208-230/60/3	
AMPERAGE	8.4 A ( 5 Min. Freeze AT 104°F / WT 80°F)	
MINIMUM CIRCUIT AMPACITY	20 A	
MAXIMUM FUSE SIZE	20 A	
ELECTRIC & WATER CONSUMPTION	90/70°F	70/50°F
ELECTRIC W (kWH/100 lbs.)	2640(4.55)	2460(3.97)
WATER gal./24HR (gal./100 lbs.)	267(19.2)	498(33.5)
ICE PRODUCTION PER CYCLE	28.3 lbs. (12.8 kg) 1440 pcs.	
BIN CONTROL SYSTEM	Thermostat	
REFRIGERANT CHARGE	R-404A, 22 lb. 4.3 oz. (10,100g) (Icemaker 14 lbs. 8.8 oz. Cond. Unit 7 lb. 11.5 oz.)	

### Performance Data

APPROXIMATE ICE PRODUCTION PER 24 HR.	AMBIENT TEMP. (°F/°C)	WATER TEMP. (°F/°C)					
		50/10		70/21		90/32	
	70/21	<b>1486</b>	<u>674</u>	1458	<u>661</u>	1366	<u>620</u>
	80/27	1465	<u>664</u>	1422	<u>645</u>	1300	<u>590</u>
	90/32	1458	<u>661</u>	<b>1391</b>	<u>631</u>	1280	<u>581</u>
lbs./day kg./day	100/38	1422	<u>645</u>	1365	<u>619</u>	1178	<u>534</u>
APPROXIMATE ELECTRIC CONSUMPTION	70/21	<b>2460</b>		2513		2553	
	80/27	2500		2582		2605	
	90/32	2513		<b>2640</b>		2671	
watts	100/38	2510		2647		2700	
APPROXIMATE WATER CONSUMPTION PER 24 HR.	70/21	<b>498</b>	<u>1.88</u>	430	<u>1.63</u>	375	<u>1.42</u>
	80/27	446	<u>1.69</u>	341	<u>1.29</u>	307	<u>1.16</u>
	90/32	430	<u>1.63</u>	<b>267</b>	<u>1.01</u>	223	<u>0.84</u>
gal./day m <sup>3</sup> /day	100/38	344	<u>1.30</u>	257	<u>0.97</u>	183	<u>0.69</u>
FREEZING CYCLE TIME	70/21	<b>23</b>		25		26	
	80/27	24		26		28	
	90/32	25		<b>27</b>		29	
min.	100/38	25		28		31	
HARVEST CYCLE TIME	70/21	<b>4.7</b>		4.2		3.7	
	80/27	4.3		3.5		3.2	
	90/32	4.2		<b>2.9</b>		2.5	
min.	100/38	3.5		2.8		2.2	
HEAD PRESSURE	70/21	<b>210</b>	<u>14.8</u>	233	<u>16.4</u>	249	<u>17.5</u>
	80/27	228	<u>16.0</u>	264	<u>18.6</u>	270	<u>19.0</u>
	90/32	233	<u>16.4</u>	<b>290</b>	<u>20.4</u>	300	<u>21.1</u>
PSIG kg/cm <sup>2</sup> G	100/38	231	<u>16.2</u>	292	<u>20.6</u>	310	<u>21.8</u>
SUCTION PRESSURE	70/21	<b>37</b>	<u>2.6</u>	39	<u>2.7</u>	41	<u>2.9</u>
	80/27	39	<u>2.7</u>	41	<u>2.9</u>	44	<u>3.1</u>
	90/32	39	<u>2.7</u>	<b>43</b>	<u>3.1</u>	46	<u>3.2</u>
PSIG kg/cm <sup>2</sup> G	100/38	39	<u>2.8</u>	44	<u>3.1</u>	48	<u>3.4</u>

TOTAL HEAT OF REJECTION FROM CONDENSER	24,300 BTU/h [AT 90°F (32°C) / WT 70°F (21°C)]
TOTAL HEAT OF REJECTION FROM COMPRESSOR	3,200 BTU/h [AT 90°F (32°C) / WT 70°F (21°C)]
CONDENSER VOLUME	214 CU. IN. (URC-22F)

# C. Wiring Diagrams

## 1. Diagrams Without Harvest Pump Timer Relays

### a) KM-320M\_H, KM-515M\_H, KM-600MAH

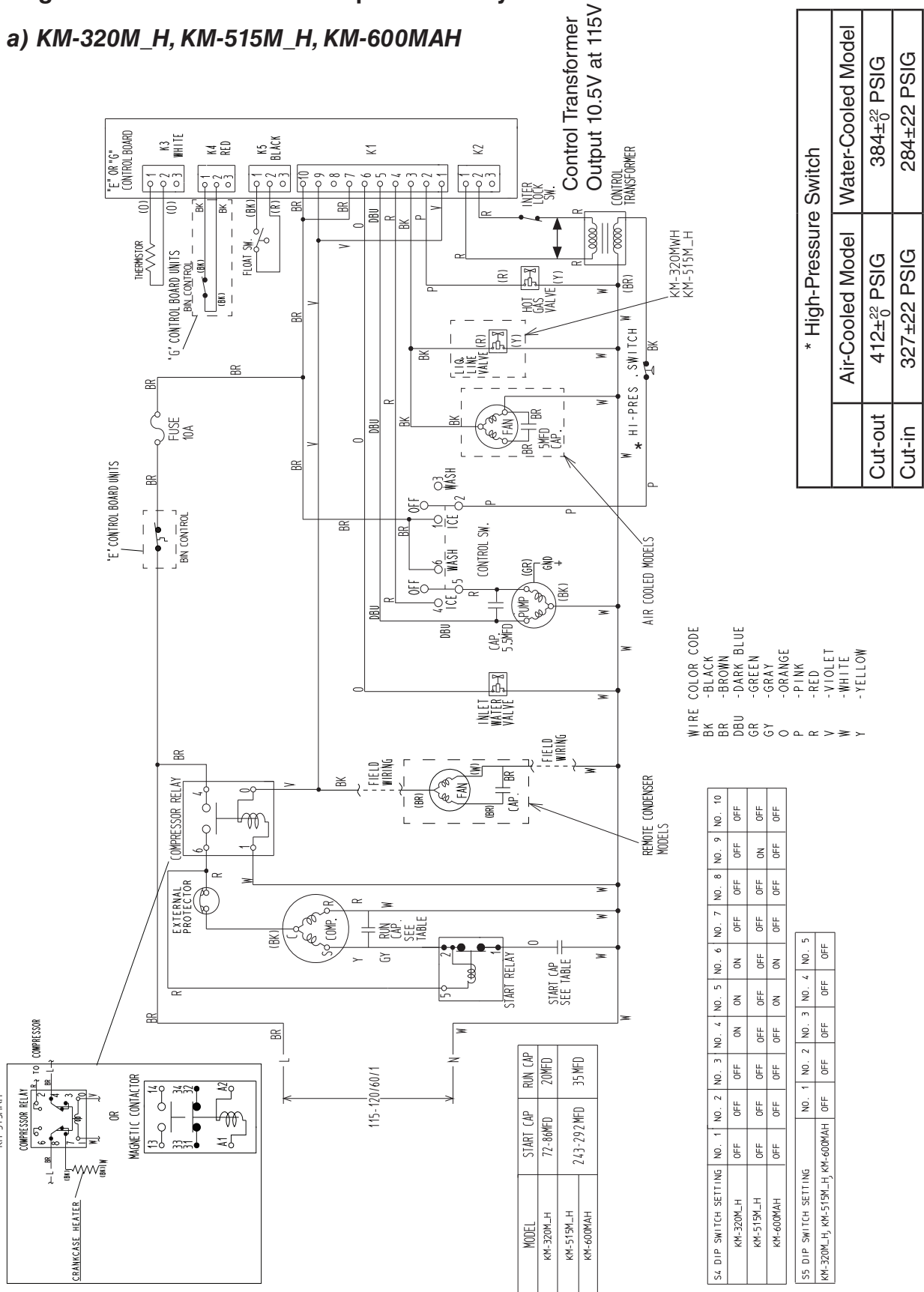

**b) KM-650MAH (V-1 and earlier), KM-650MWH (V-1 and earlier),  
KM-901MAH (B-0 and earlier), KM-901MWH (C-0 and earlier)**

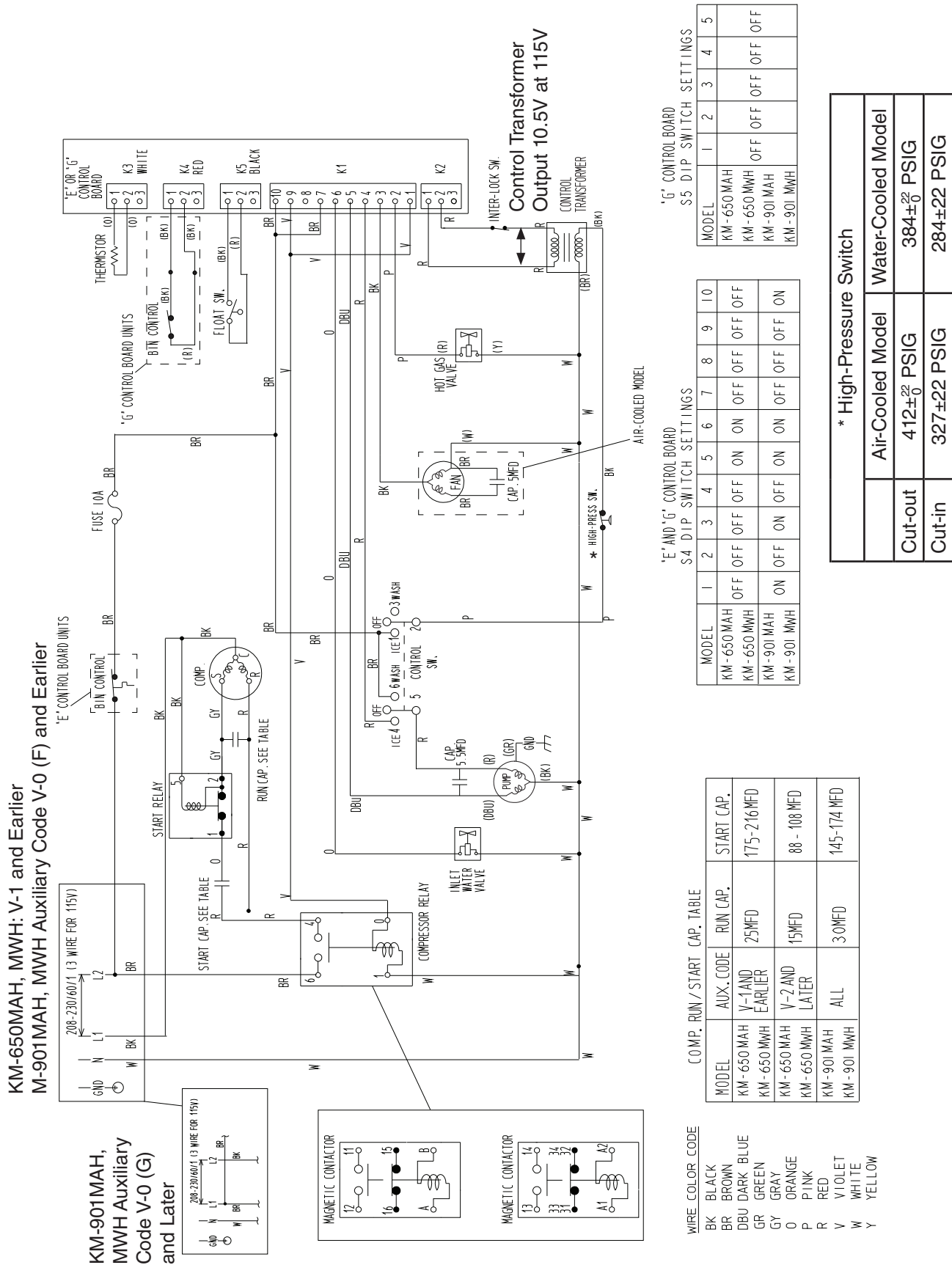

c) KM-650MRH (V-1 and earlier), KM-901MRH (C-0 and earlier)

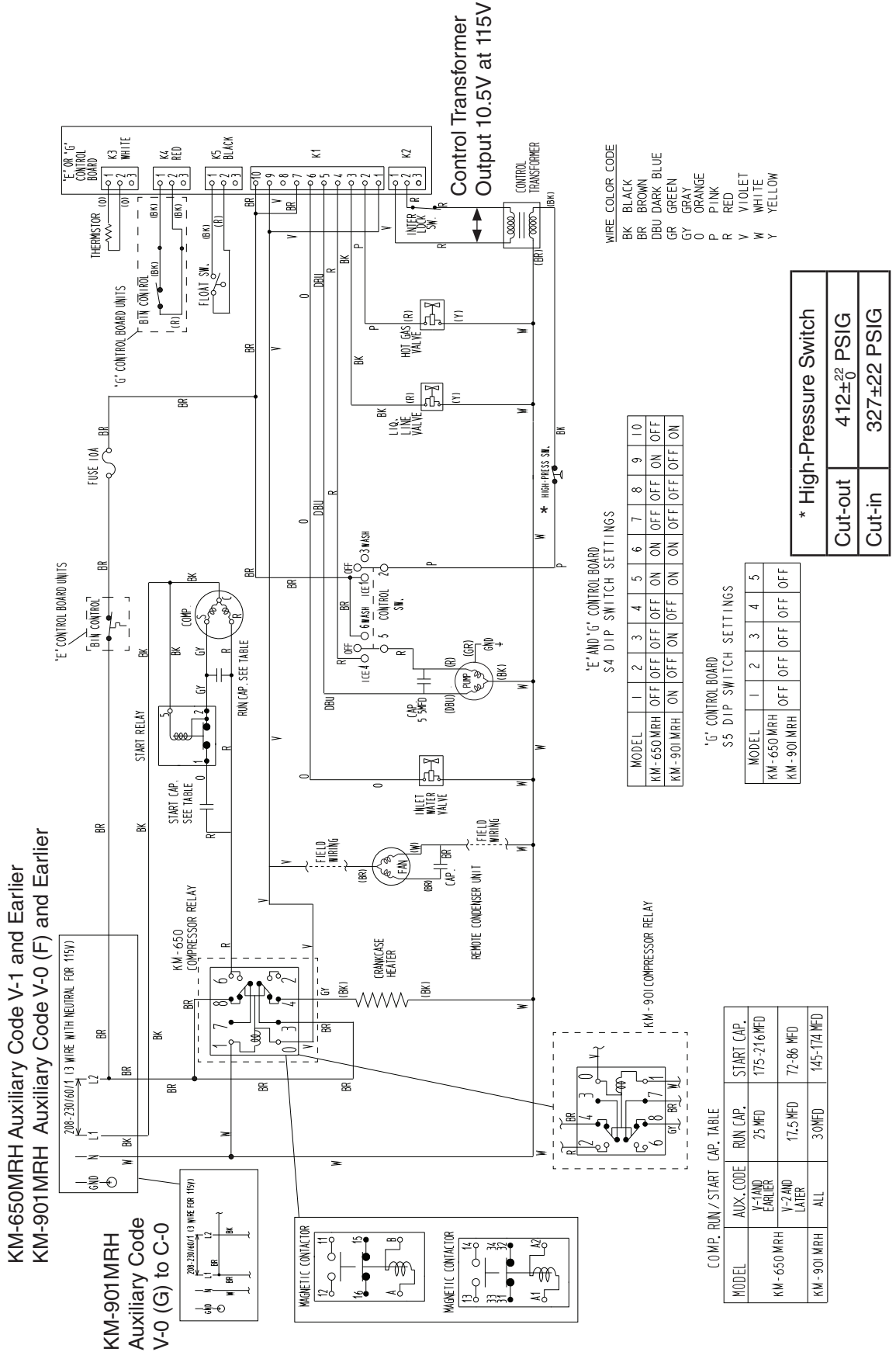

**d) KM-901MWH (D-1 and later), KM-901MRH (C-1 and later)**

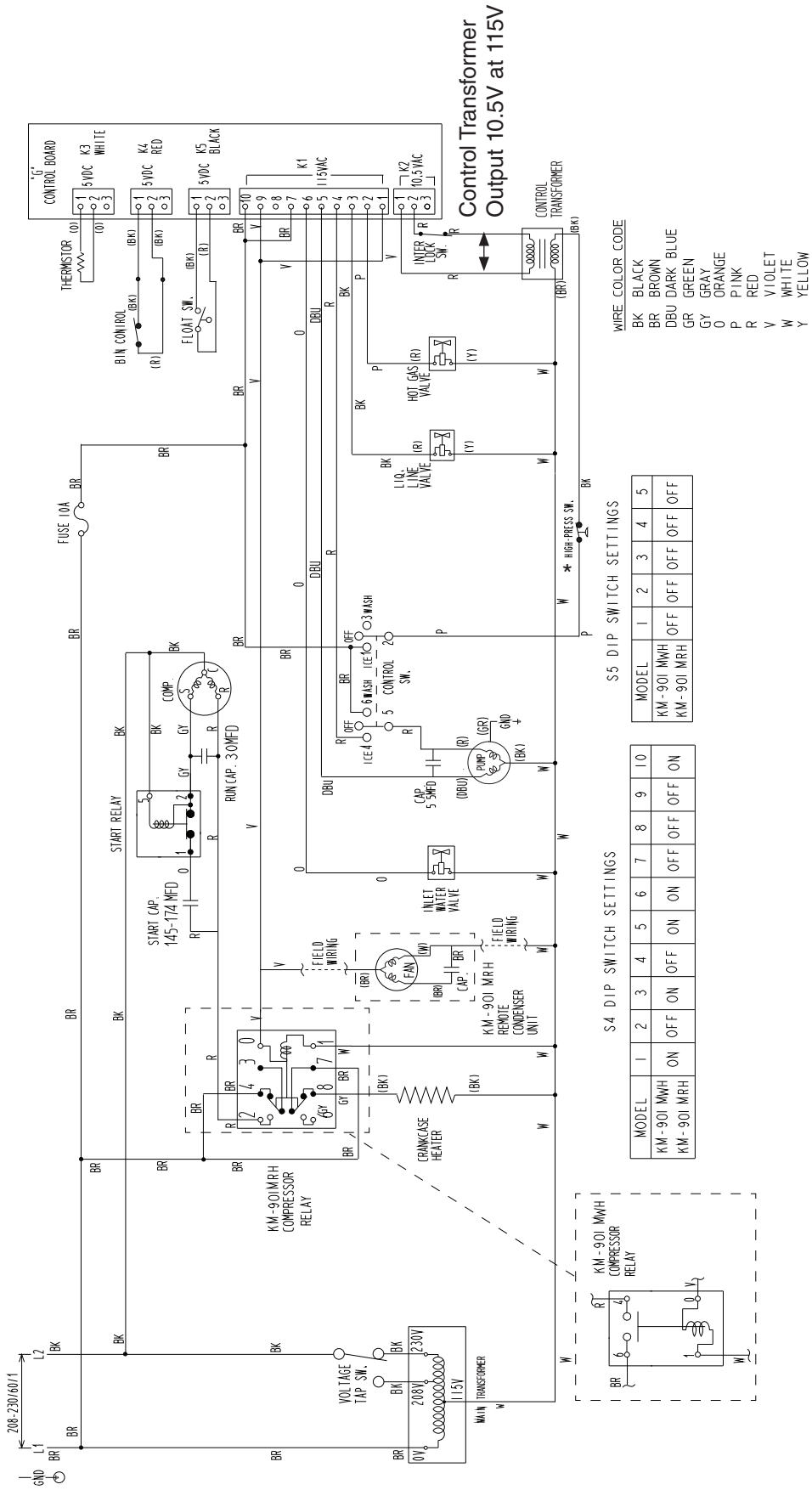

* High-Pressure Switch	
Water-Cooled Model	Remote Model
Cut-out 384± <sup>22</sup> / <sub>0</sub> PSIG	412± <sup>22</sup> / <sub>0</sub> PSIG
Cut-in 284±22 PSIG	327±22 PSIG

e) KM-1340MAH, KM-1340MWH

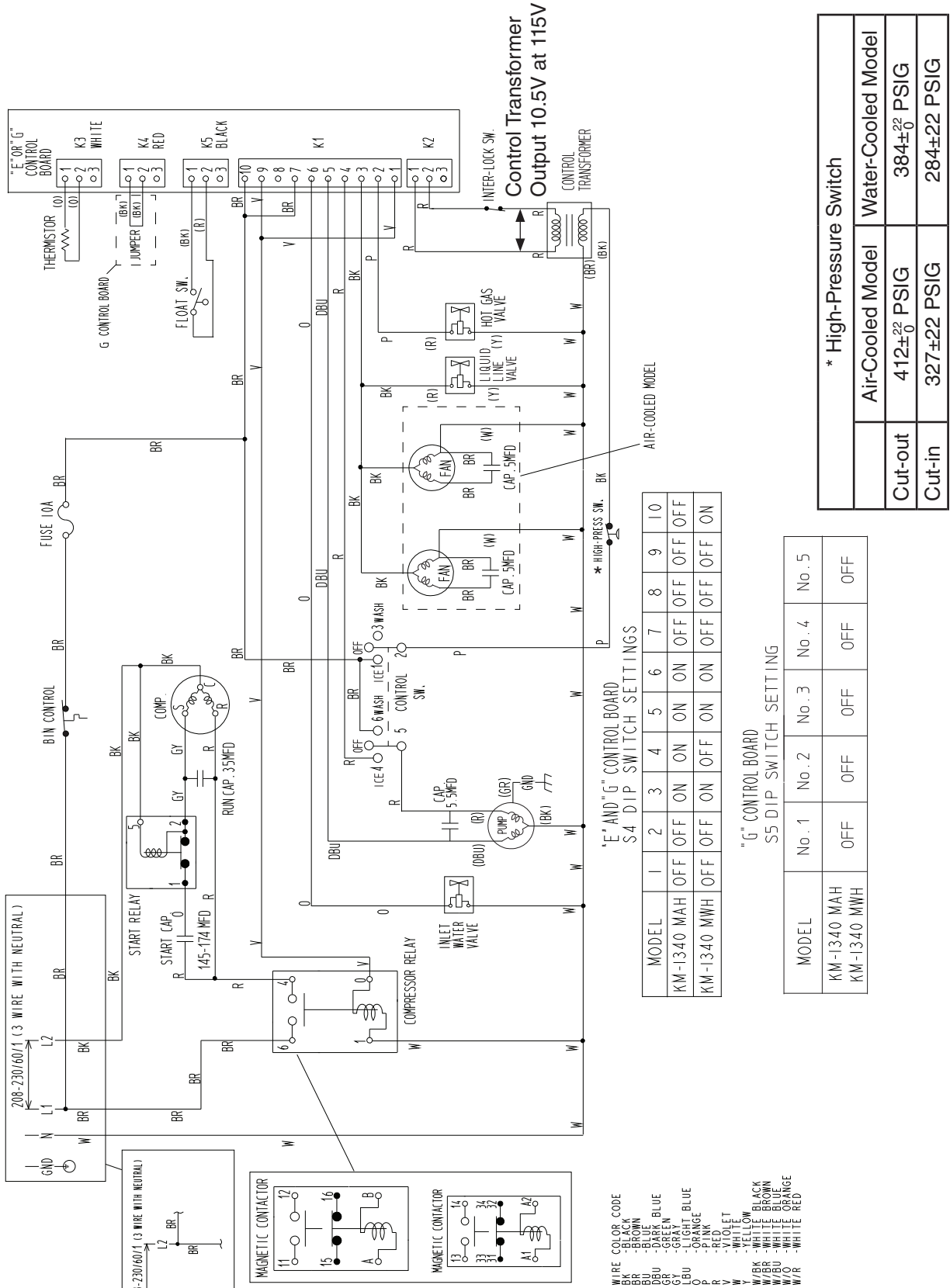

f) KM-1340MRH

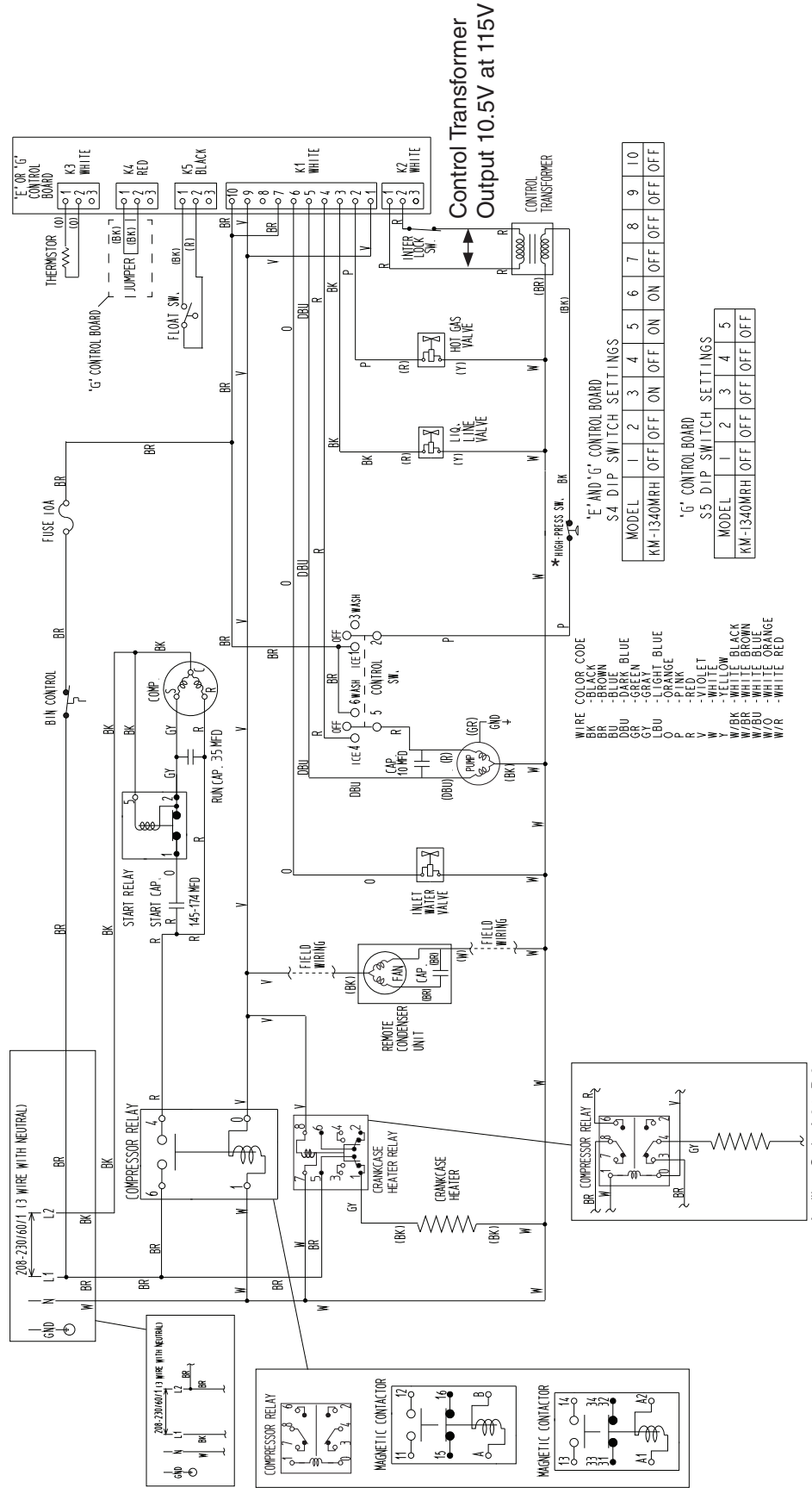

* High-Pressure Switch	
Cut-out	412±2 PSIG
Cut-in	327±22 PSIG

**g) KM-1601MRH**

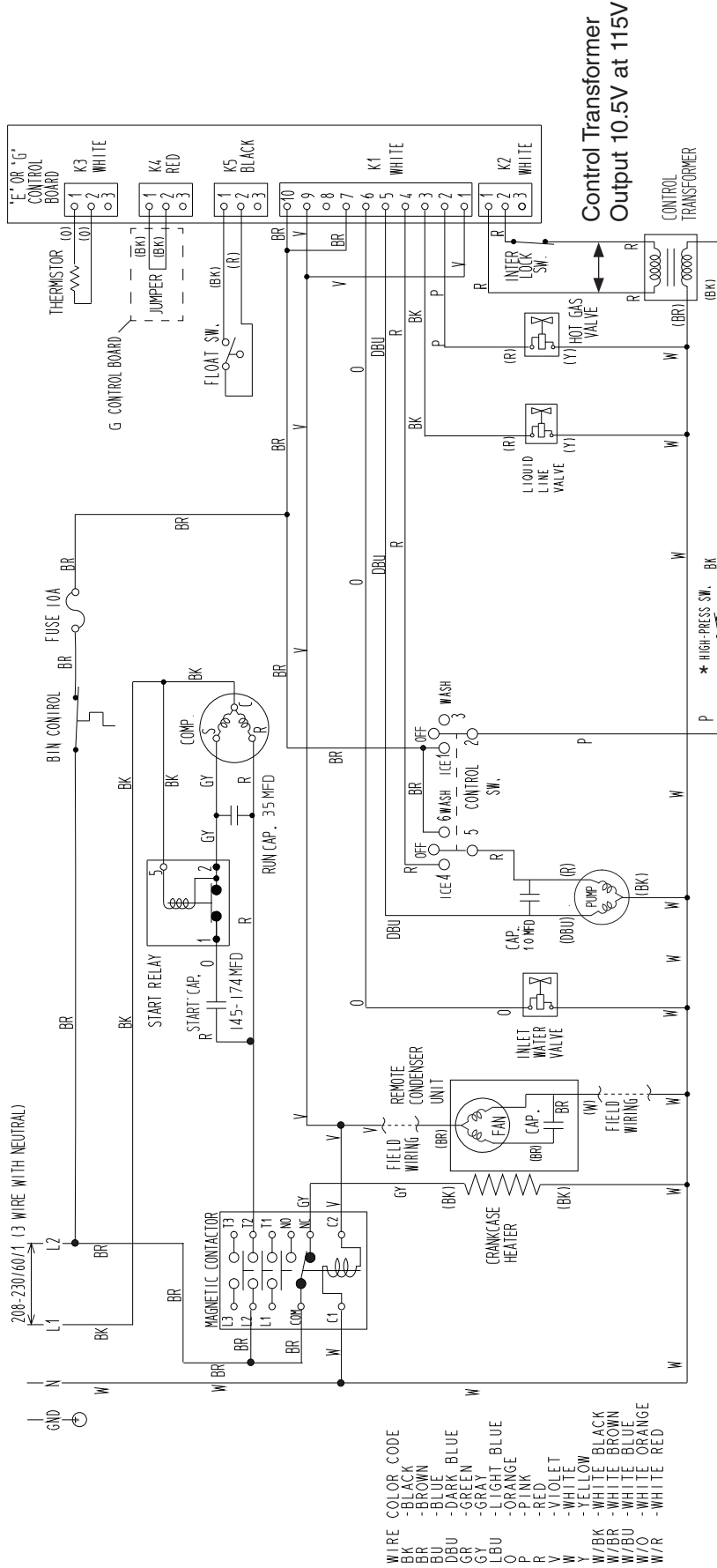

- WIRE COLOR CODE**
- BLACK
  - BROWN
  - BLUE
  - DARK BLUE
  - GREEN
  - GRAY
  - LIGHT BLUE
  - ORANGE
  - PINK
  - RED
  - VIOLET
  - WHITE
  - YELLOW
  - W/BK
  - W/BR
  - W/BU
  - W/O
  - W/R

**'E' AND 'G' CONTROL BOARD**

**S4 DIP SWITCH SETTINGS**

MODEL	1	2	3	4	5	6	7	8	9	10
KM-1601MRH	OFF	OFF	ON	OFF	ON	ON	OFF	OFF	OFF	ON

**'G' CONTROL BOARD**

**S5 DIP SWITCH SETTINGS**

MODEL	1	2	3	4	5
KM-1601MRH	OFF	OFF	OFF	OFF	OFF

* High-Pressure Switch	
Cut-out	412 ± <sup>22</sup> / <sub>0</sub> PSIG
Cut-in	327 ±22 PSIG

### h) KM-901MRH3, KM-1340MRH3, KM-1601MRH3

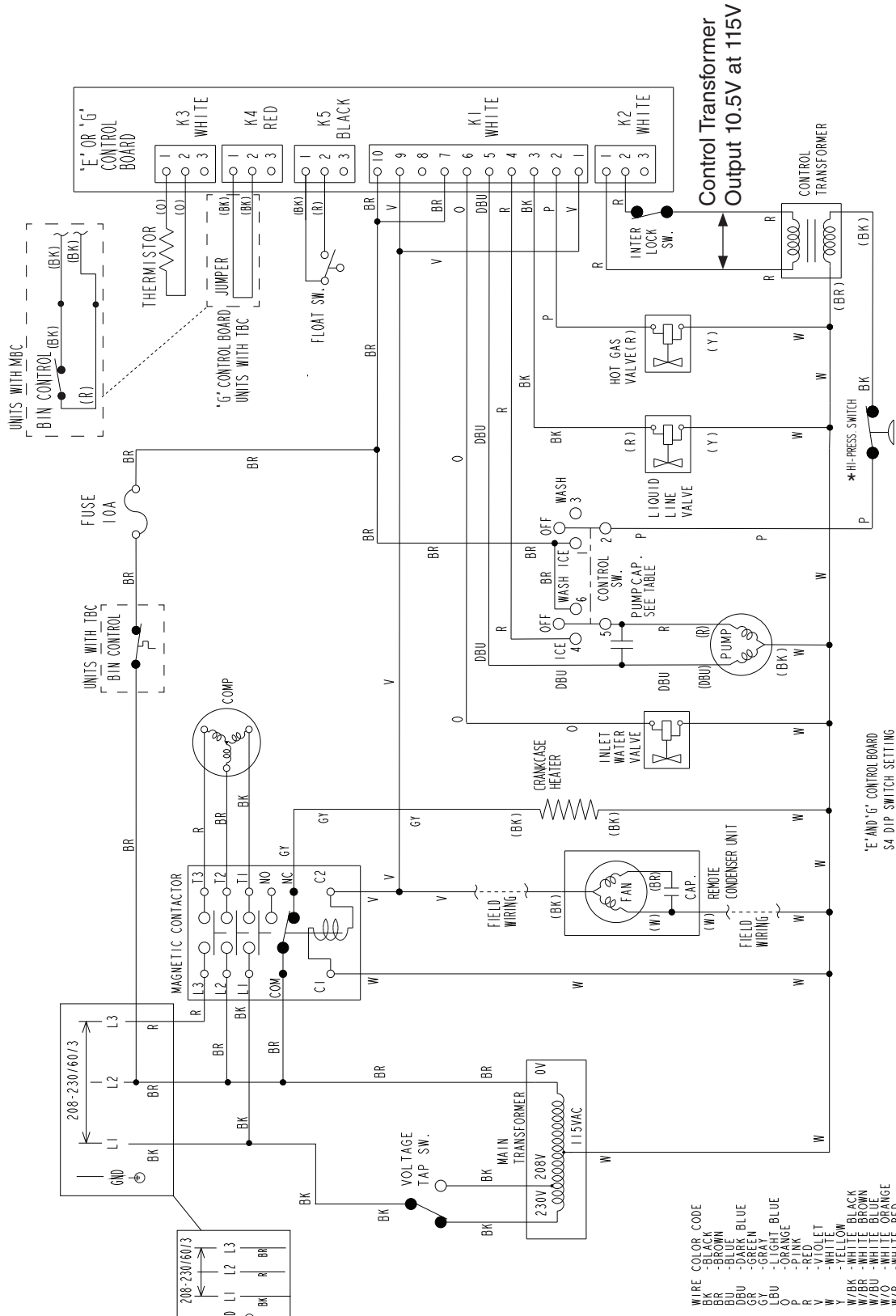

- WIRE COLOR CODE**
- BK - BLACK
  - BR - BROWN
  - BU - BLUE
  - DBU - DARK BLUE
  - GR - DARK GREEN
  - GY - GRAY
  - DBU - DUBU
  - O - OIL
  - P - PINK
  - R - RED
  - V - VIOLET
  - W - WHITE
  - Y - YELLOW
  - W/BK - WHITE/BLACK
  - W/BR - WHITE/BROWN
  - W/BU - WHITE/BLUE
  - W/O - WHITE/ORANGE
  - W/R - WHITE/RED

**PUMP CAP. TABLE**

MODEL	CAP.
KM-901MRH3	5.5MFD
KM-1340MRH3	10MFD
KM-1601MRH3	

**\*E\* AND \*G\* CONTROL BOARD**  
S4 DIP SWITCH SETTING

MODEL	NO. 1	NO. 2	NO. 3	NO. 4	NO. 5	NO. 6	NO. 7	NO. 8	NO. 9	NO. 10
KM-901MRH3	ON	OFF	ON	OFF	ON	ON	OFF	OFF	OFF	ON
KM-1340MRH3	OFF	OFF	ON	OFF	ON	ON	OFF	OFF	OFF	OFF
KM-1601MRH3	OFF	OFF	ON	OFF	ON	ON	OFF	OFF	OFF	ON

**\*G\* CONTROL BOARD**  
S5 DIP SWITCH SETTING

MODEL	NO. 1	NO. 2	NO. 3	NO. 4	NO. 5
ALL	OFF	OFF	OFF	OFF	OFF

**\* High-Pressure Switch**

Cut-out	412±22 PSIG
Cut-in	327±22 PSIG

## 2. Diagrams With Harvest Pump Timer Relays

### a) KM-340M\_H

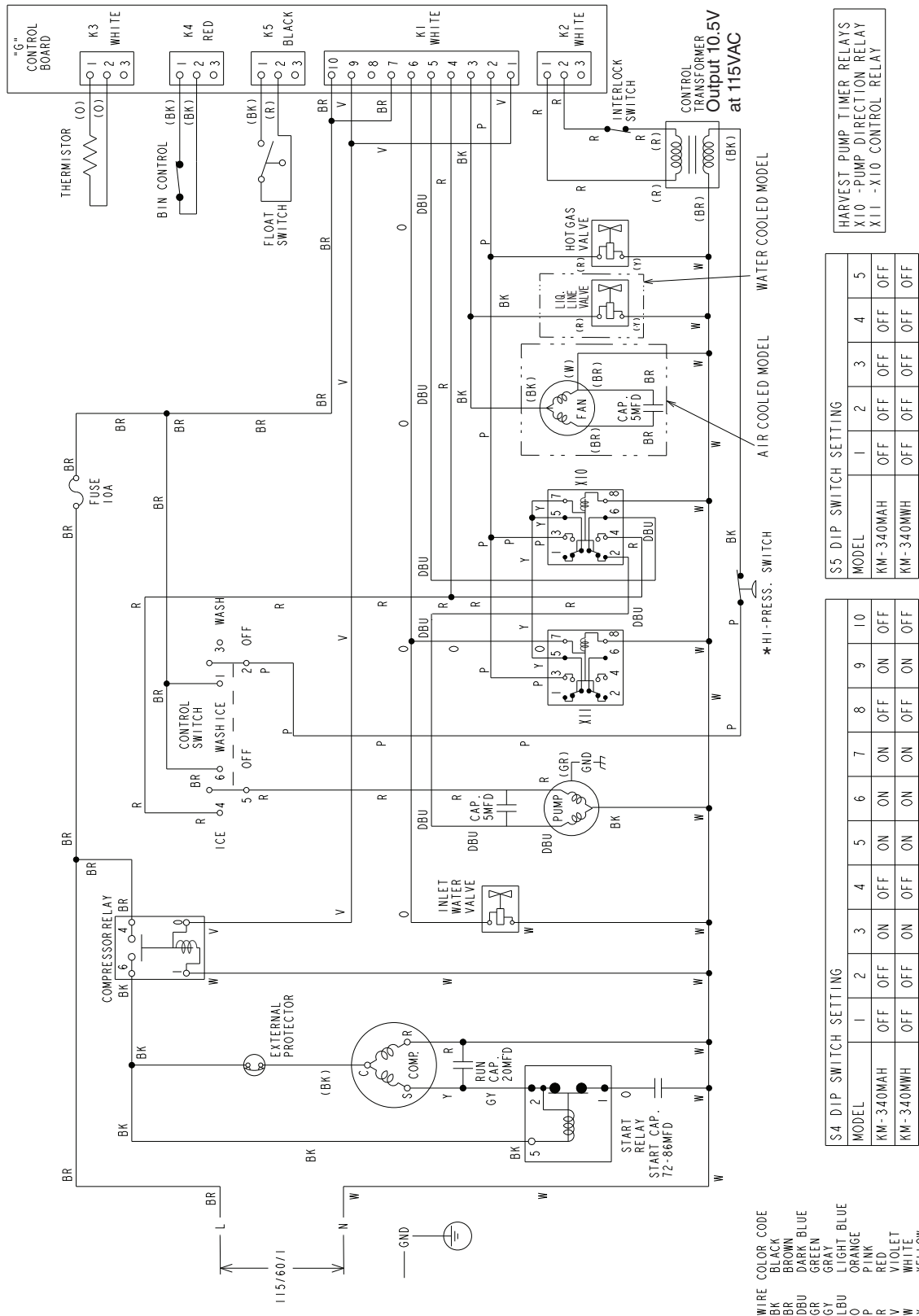

WIRE COLOR CODE

BK	BLACK
BR	BROWN
DBU	DARK BLUE
GR	GREEN
GY	GRAY
LBU	LIGHT BLUE
O	ORANGE
P	PINK
R	RED
V	VIOLET
W	WHITE
Y	YELLOW
W/BR	WHITE/BLACK
W/BR	WHITE/BROWN
W/BU	WHITE/BLUE
W/O	WHITE/ORANGE
W/R	WHITE/RED

S4 DIP SWITCH SETTING

MODEL	1	2	3	4	5	6	7	8	9	10
KM-340MAH	OFF	OFF	ON	OFF	ON	ON	ON	OFF	ON	OFF
KM-340MWH	OFF	OFF	ON	OFF	ON	ON	ON	OFF	ON	OFF

S5 DIP SWITCH SETTING

MODEL	1	2	3	4	5
KM-340MAH	OFF	OFF	OFF	OFF	OFF
KM-340MWH	OFF	OFF	OFF	OFF	OFF

HARVEST PUMP TIMER RELAYS  
 X10 - PUMP DIRECTION RELAY  
 X11 - X10 CONTROL RELAY

\* High-Pressure Switch

	Air-Cooled Model	Water-Cooled Model
Cut-out	412±22 PSIG	384±22 PSIG
Cut-in	327±22 PSIG	284±22 PSIG

b) KM-515MAH

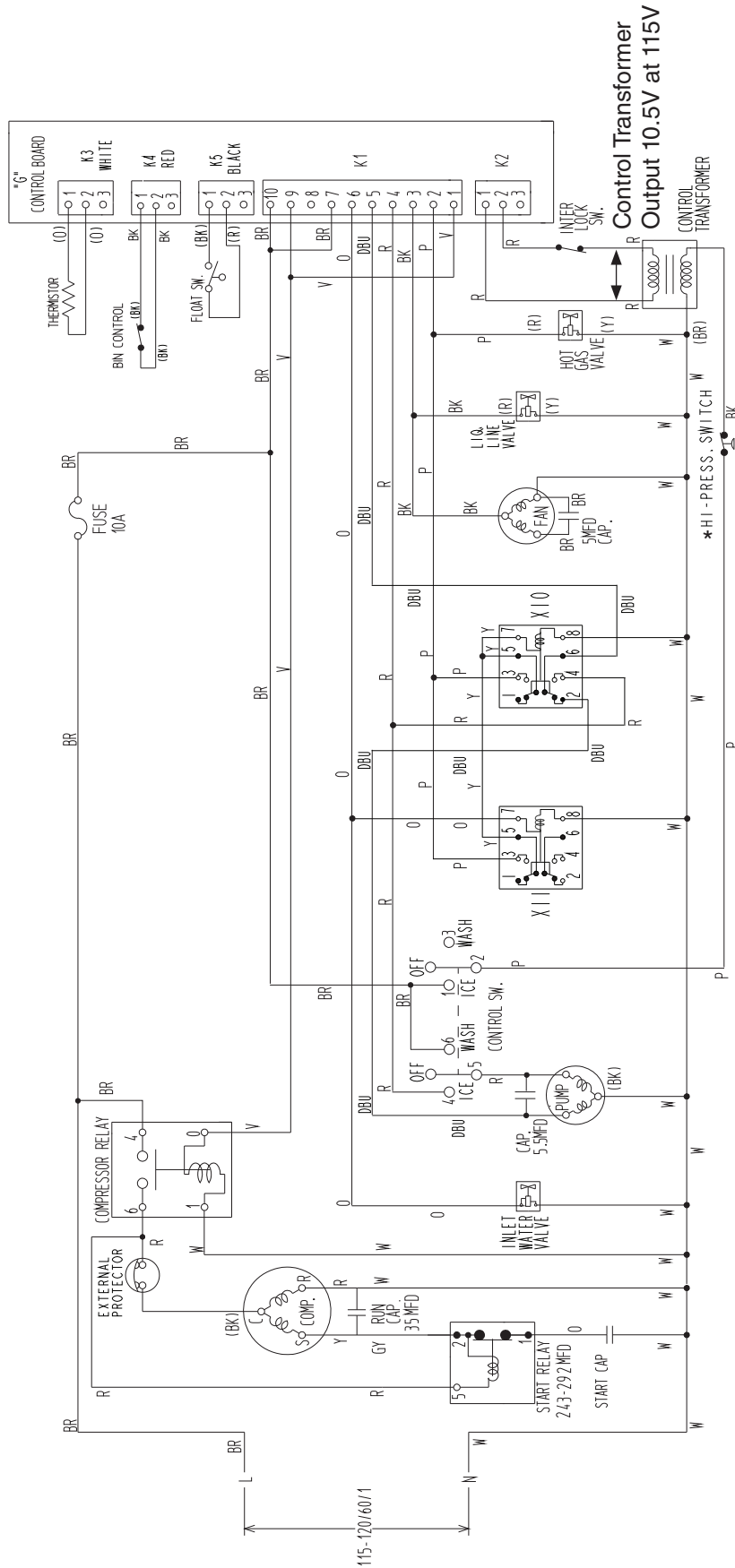

- WIRE COLOR CODE
- BK -BLACK
  - BR -BROWN
  - DBU -DARK BLUE
  - GR -GREEN
  - GY -GRAY
  - O -ORANGE
  - P -PINK
  - R -RED
  - V -VIOLET
  - W -WHITE
  - Y -YELLOW

S4 DIP SWITCH SETTINGS

MODEL	1	2	3	4	5	6	7	8	9	10
KM-515MAH	OFF	OFF	OFF	OFF	ON	ON	ON	OFF	ON	OFF

S5 DIP SWITCH SETTINGS

MODEL	1	2	3	4	5
KM-515MAH	OFF	OFF	OFF	OFF	OFF

\* High-Pressure Switch

Cut-out	412±2 PSIG
Cut-in	327±22 PSIG

c) KM-650MAH (V-2 to C-2), KM-650MWH (V-2 to C-2),  
 KM-901MAH (B-1 to C-2)

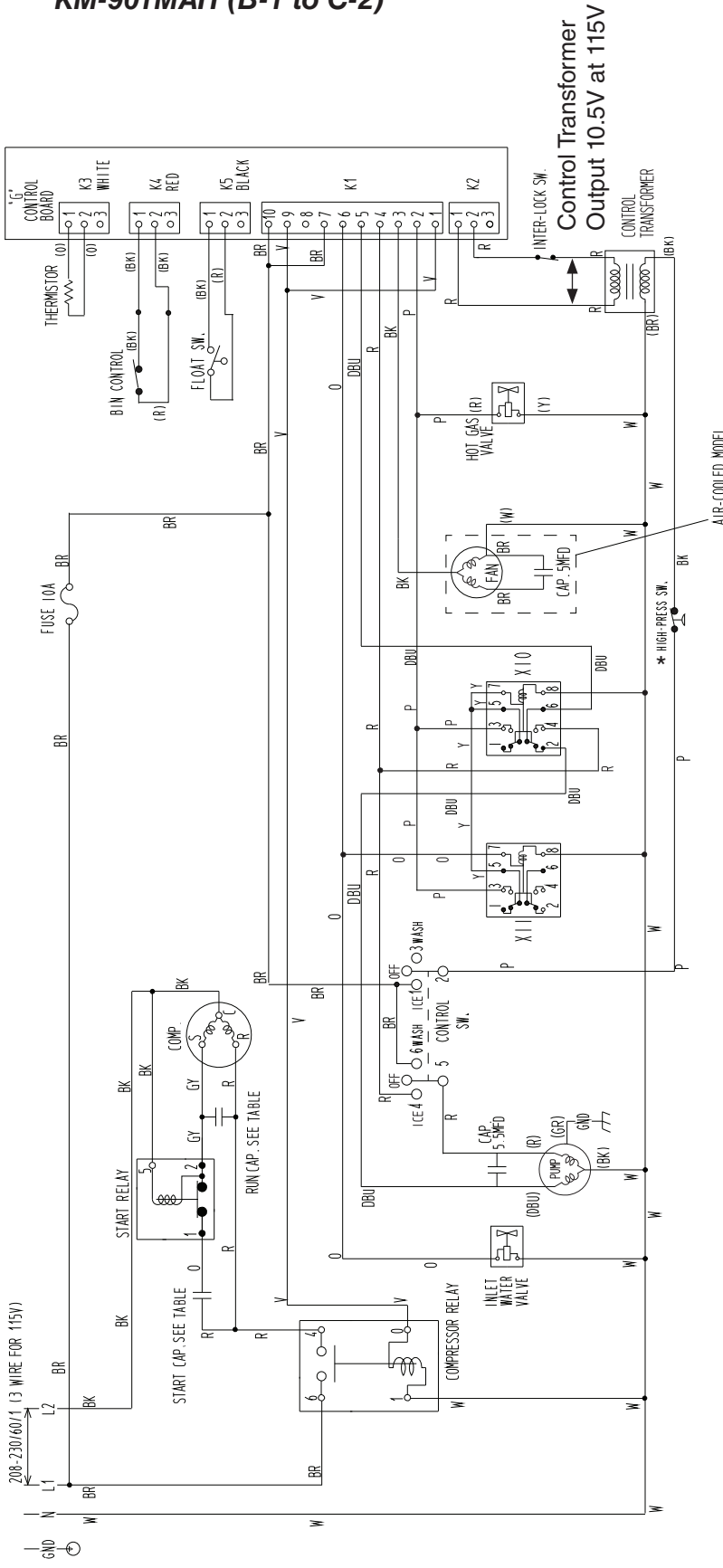

- WIRE COLOR CODE
- BK BLACK
  - BR BROWN
  - DBU DARK BLUE
  - GR GREEN
  - GY GRAY
  - O ORANGE
  - P PINK
  - R RED
  - V VIOLET
  - W WHITE
  - Y YELLOW

COMP. RUN / START CAP. TABLE

MODEL	RUN CAP.	START CAP.
KM-650 MAH	17.5 MFD	72-86 MFD
KM-650 MWH		
KM-901 MAH	30 MFD	145-174 MFD

S4 DIP SWITCH SETTINGS

MODEL	1	2	3	4	5	6	7	8	9	10
KM-650 MAH	ON	OFF	OFF	OFF	ON	ON	ON	OFF	OFF	OFF
KM-650 MWH	OFF	OFF	OFF	OFF	ON	ON	ON	OFF	OFF	OFF
KM-901 MAH	OFF	OFF	OFF	ON	OFF	ON	ON	OFF	OFF	ON

S5 DIP SWITCH SETTINGS

MODEL	1	2	3	4	5
KM-650 MAH	OFF	OFF	OFF	OFF	OFF
KM-650 MWH	OFF	OFF	OFF	OFF	OFF
KM-901 MAH	OFF	OFF	OFF	OFF	OFF

\* High-Pressure Switch

	Air-Cooled Model	Water-Cooled Model
Cut-out	412±22 PSIG	384±22 PSIG
Cut-in	327±22 PSIG	284±22 PSIG

**d) KM-650MAH (D-1 and later), KM-650MWH (D-1 and later),  
KM-901MAH (D-1 and later)**

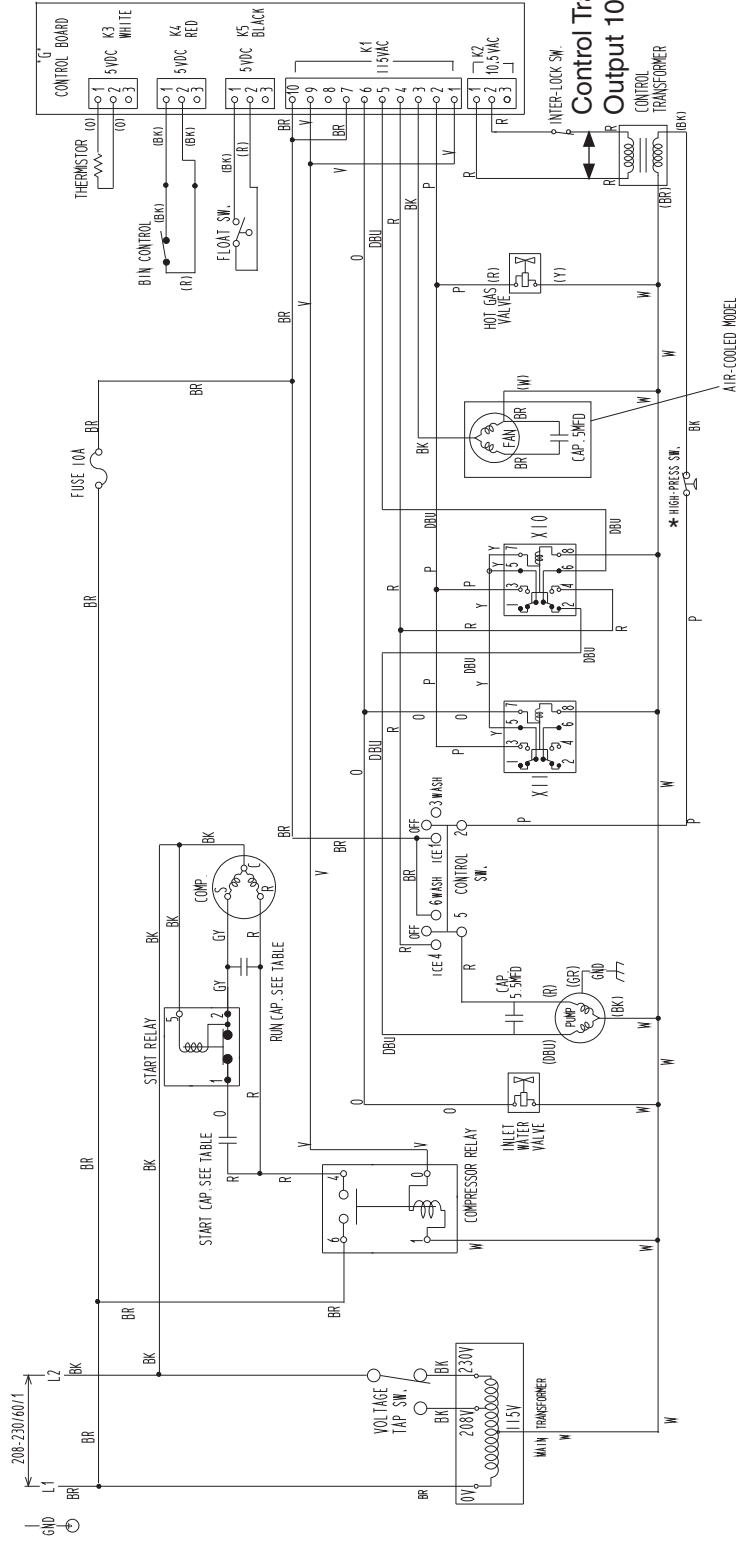

**WIRE COLOR CODE**  
 BK BLACK  
 BR BROWN  
 DBU DARK BLUE  
 GR GREEN  
 GY GRAY  
 O ORANGE  
 P PINK  
 R RED  
 V VIOLET  
 W WHITE  
 Y YELLOW

**COMP. RUN / START CAP. TABLE**

MODEL	RUN CAP.	START CAP.
KM-650MAH	17.5 MFD	72-86MFD
KM-650MWH	3.0MFD	145-174 MFD

**S4 DIP SWITCH SETTINGS**

MODEL	1	2	3	4	5	6	7	8	9	10
KM-650MAH	ON	OFF	OFF	OFF	ON	ON	ON	OFF	OFF	OFF
KM-650MWH	OFF	OFF	OFF	OFF	ON	ON	ON	OFF	OFF	OFF
KM-901MAH	OFF	OFF	ON	OFF	ON	ON	ON	OFF	OFF	ON

**S5 DIP SWITCH SETTINGS**

MODEL	1	2	3	4	5
KM-650MAH	OFF	OFF	OFF	OFF	OFF
KM-650MWH	OFF	OFF	OFF	OFF	OFF
KM-901MAH	OFF	OFF	OFF	OFF	OFF

**\* High-Pressure Switch**

Model	Water-Cooled Model
Cut-out	412±22 PSIG
Cut-in	384±22 PSIG
	284±22 PSIG

e) KM-650MRH (V-2 to C-1)

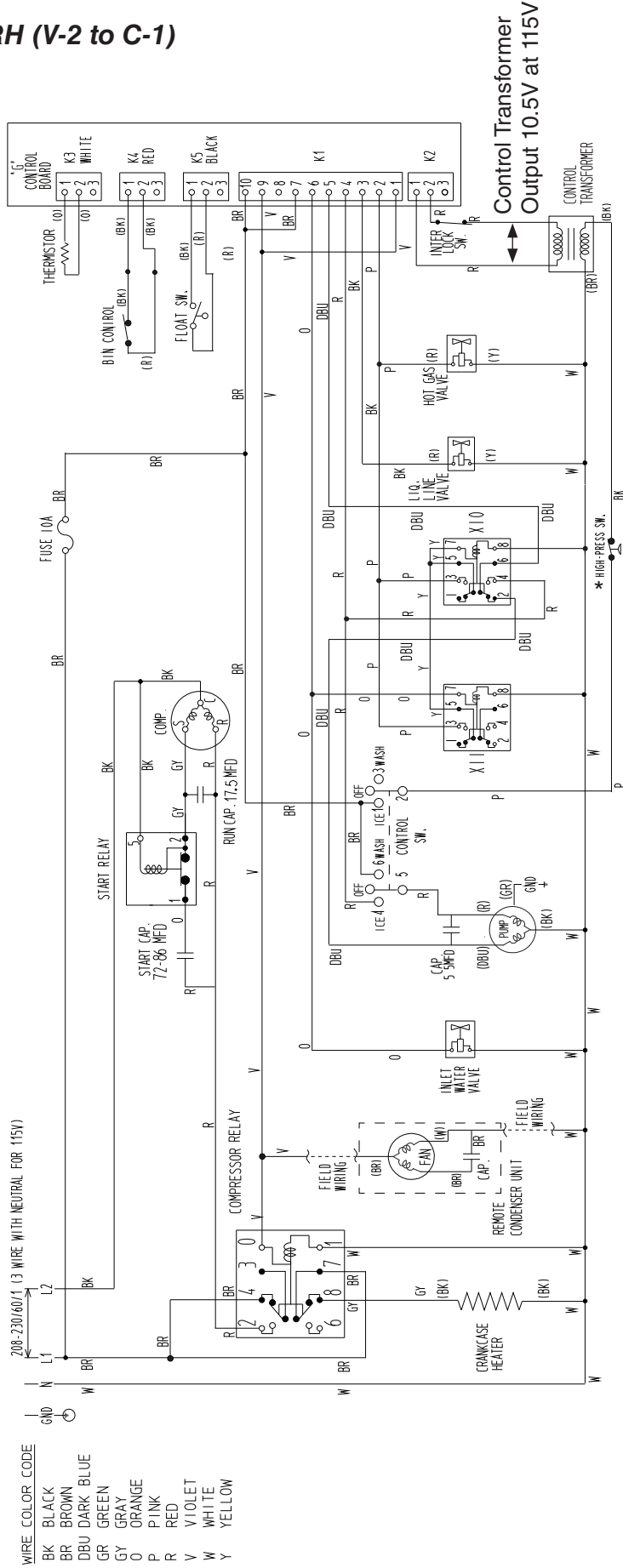

WIRE COLOR CODE

BK	BLACK
BR	BROWN
DBU	DARK BLUE
GR	GREEN
GY	GRAY
O	ORANGE
P	PINK
R	RED
V	VIOLET
W	WHITE
Y	YELLOW

Control Transformer  
Output 10.5V at 115V

S4 DIP SWITCH SETTINGS

MODEL	1	2	3	4	5	6	7	8	9	10
KM-650MRH	ON	OFF	OFF	OFF	ON	ON	ON	OFF	OFF	OFF

S5 DIP SWITCH SETTINGS

MODEL	1	2	3	4	5
KM-650MRH	OFF	OFF	OFF	OFF	OFF

* High-Pressure Switch	
Cut-out	412±2 <sub>0</sub> PSIG
Cut-in	327±22 PSIG

f) KM-650MRH (C-2 and later)

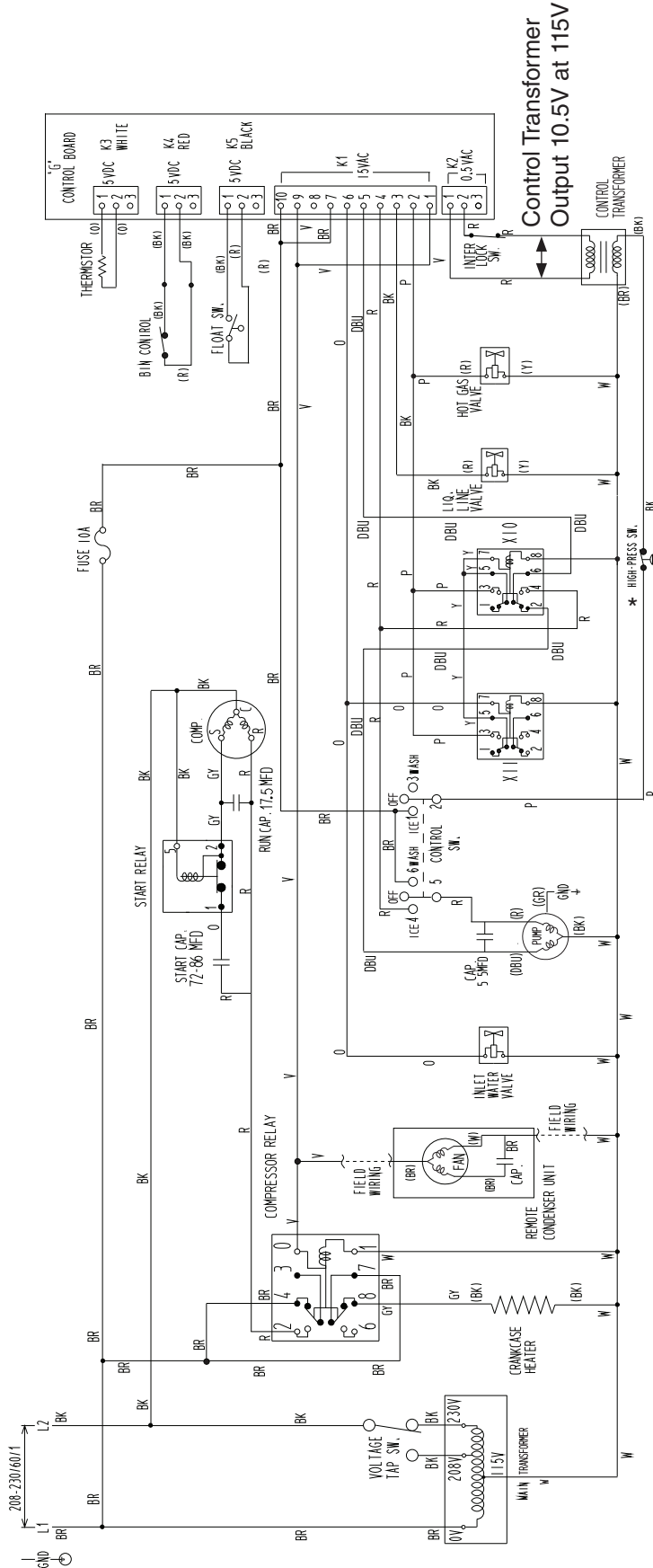

Control Transformer  
Output 10.5V at 115V

WIRE COLOR CODE

BK	BLACK
BR	BROWN
DBU	DARK BLUE
GR	GREEN
GY	GRAY
O	ORANGE
P	PINK
R	RED
V	VIOLET
W	WHITE
Y	YELLOW

S5 DIP SWITCH SETTINGS

MODEL	1	2	3	4	5
KM-650MRH	OFF	OFF	OFF	OFF	OFF

S4 DIP SWITCH SETTINGS

MODEL	1	2	3	4	5	6	7	8	9	10
KM-650MRH	ON	OFF	OFF	OFF	ON	ON	ON	OFF	OFF	OFF

\* High-Pressure Switch

Cut-out	412±22 PSIG
Cut-in	327±22 PSIG

# g) KM-1100M\_H

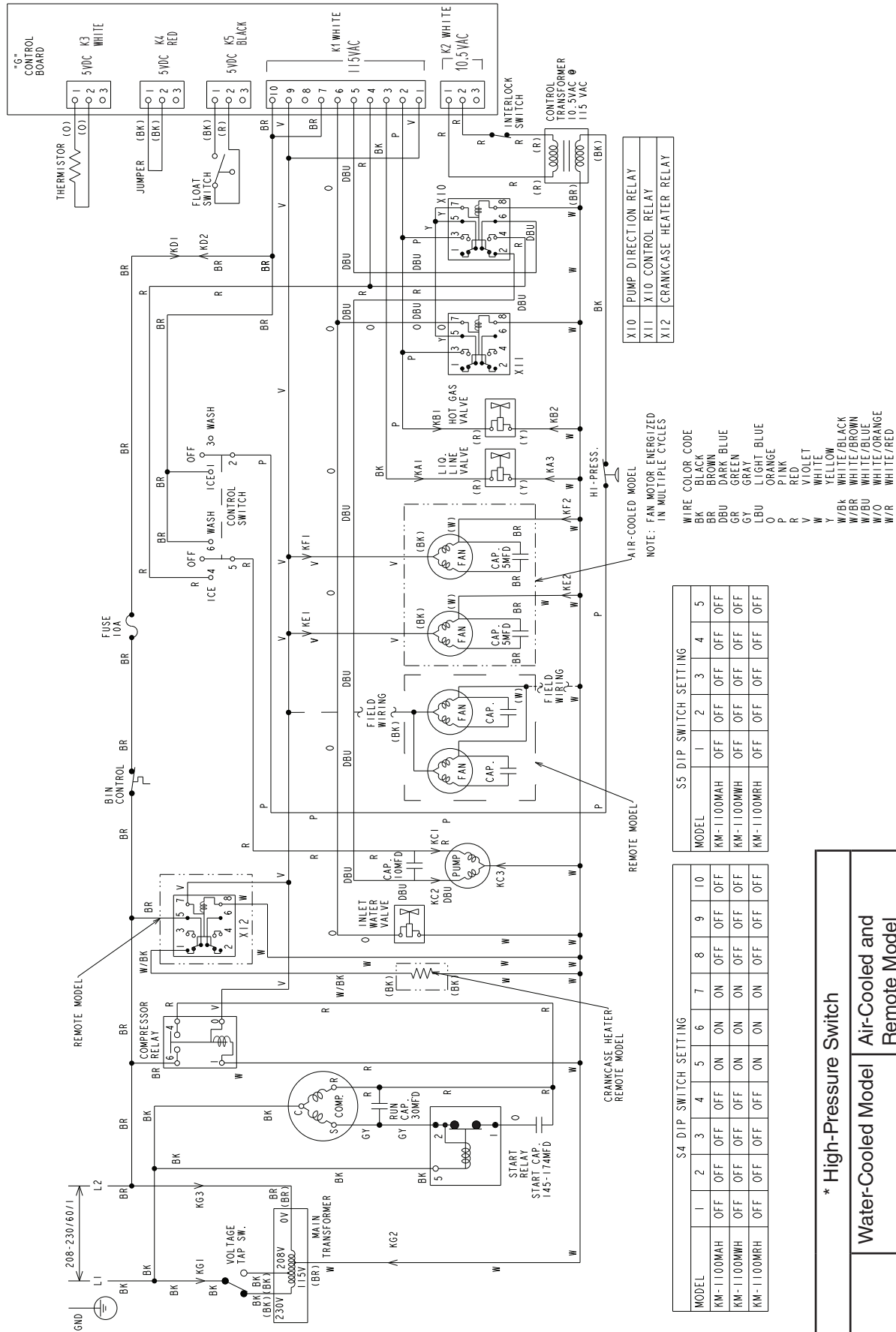

**\* High-Pressure Switch**

Water-Cooled Model	Air-Cooled and Remote Model
Cut-out	384±22 PSIG
Cut-in	284±22 PSIG