

Hoshizaki America, Inc.

Modular Crescent Cuber

Models

KMD-450MAH

KMD-450MWH



“A Superior Degree
of Reliability”

www.hoshizaki.com

SERVICE MANUAL



Number: 73161
Issued: 9-3-2009

IMPORTANT

Only qualified service technicians should install, service, and maintain the icemaker. No service or maintenance should be undertaken until the technician has thoroughly read this Service Manual. Failure to service and maintain the equipment in accordance with this manual may adversely affect safety, performance, component life, and warranty coverage.

Hoshizaki provides this manual primarily to assist qualified service technicians in the service and maintenance of the icemaker.

Should the reader have any questions or concerns which have not been satisfactorily addressed, please call, write, or send an e-mail message to the Hoshizaki Technical Support Department for assistance.

HOSHIZAKI AMERICA, INC.
618 Highway 74 South
Peachtree City, GA 30269

Attn: Hoshizaki Technical Support Department

Phone: 1-800-233-1940 Technical Support
(770) 487-2331

Fax: 1-800-843-1056
(770) 487-3360

E-mail: techsupport@hoshizaki.com

Web Site: www.hoshizaki.com

NOTE: To expedite assistance, all correspondence/communication MUST include the following information:

- Model Number _____
- Serial Number _____
- Complete and detailed explanation of the problem.

IMPORTANT

This manual should be read carefully before the icemaker is serviced or maintenance operations are performed. Only qualified service technicians should install, service, and maintain the icemaker. Read the warnings contained in this booklet carefully as they give important information regarding safety. Please retain this booklet for any further reference that may be necessary.

CONTENTS

Important Safety Information	6
I. Specifications.....	7
A. Icemaker	7
1. KMD-450MAH (air-cooled)	7
2. KMD-450MWH (water-cooled).....	8
II. General Information	9
A. Construction	9
1. KMD-450MAH (air-cooled)	9
2. KMD-450MWH (water-cooled).....	10
B. Sequence of Operation	11
1. Sequence Cycles and Shutdown	11
a) 1-Minute Fill Cycle	11
b) Initial Harvest Cycle	11
c) Freeze Cycle	11
d) Pump-Out Cycle	12
e) Normal Harvest Cycle	12
f) Shutdown.....	12
2. Sequence Flow Chart.....	14
C. Control Board	15
1. Control Board Layout	16
2. Features.....	17
a) Maximum Water Supply Period - 6 minutes	17
b) Harvest Backup Timer and Freeze Timer.....	17
c) High Temperature Safety.....	17
d) Low Water Safety	17
e) High Voltage and Low Voltage Cut-outs.....	17
f) LED Lights and Audible Alarm Safeties	18
3. Controls and Adjustments.....	19
a) Default Dip Switch Settings.....	19
b) Harvest Timer (S1 dip switch 1 & 2).....	20
c) Pump-Out Timer (S1 dip switch 3 & 4).....	20
d) Pump-Out Frequency Control (S1 dip switch 5 & 6)	21
e) Harvest Pump Timer (S1 dip switch 7 & 8)	21
f) Freeze Timer (S1 dip switch 9 & 10)	22
g) Pump-Out/Drain Selector (S2 dip switch 1)	22
h) Float Switch Selector (S2 dip switch 2).....	23
i) Refill Counter (S2 dip switch 3 & 4).....	23
j) Factory Use (S2 dip switch 5)	23
k) Anti-Slush Control (S2 dip switch 6).....	23

D. Bin Control	24
E. Float Switch.....	24
F. Thermistor	24
G. Switches	25
1. Control Switch	25
2. Service Switch.....	25
a) DRAIN.....	25
b) CIRCULATE	25
c) WASH.....	25
III. Technical Information	26
A. Water Circuit and Refrigeration Circuit	26
1. KMD-450MAH (air-cooled)	26
2. KMD-450MWH (water-cooled).....	27
B. Wiring Diagram and Multimeter Access Points	28
1. Wiring Diagram.....	28
2. Multimeter Access Points.....	29
a) Diagnostic Connector.....	29
b) Compressor Terminal Block	29
C. Performance Data	30
1. KMD-450MAH (air-cooled).....	30
2. KMD-450MWH (water-cooled).....	31
IV. Service Diagnosis	32
A. Diagnostic Procedure	32
B. Control Board Check	36
C. Bin Control Check and Cleaning	37
1. Bin Control Check	37
2. Bin Control Cleaning.....	37
D. Float Switch Check and Cleaning	38
1. Float Switch Check	38
2. Float Switch Cleaning.....	39
E. Thermistor Check	41
F. Diagnostic Charts	42
1. No Ice Production.....	42
2. Evaporator is Frozen Up	45
3. Low Ice Production	47
4. Abnormal Ice	48
5. Other.....	49
V. Removal and Replacement of Components	50
A. Service for Refrigerant Lines.....	50
1. Refrigerant Recovery	50
2. Brazing	51
3. Evacuation and Recharge (R-404A).....	51
B. Removal and Replacement of Compressor.....	52
C. Removal and Replacement of Expansion Valve.....	53
D. Removal and Replacement of Hot Gas Valve or Liquid Line Valve	54
E. Removal and Replacement of Evaporator.....	55
F. Removal and Replacement of Air-Cooled Condenser.....	56
G. Removal and Replacement of Water-Cooled Condenser.....	56

H. Removal and Replacement of Water Regulating Valve (water-cooled model).....	58
I. Adjustment of Water Regulating Valve (water-cooled model).....	59
J. Removal and Replacement of Thermistor.....	60
K. Removal and Replacement of Fan Motor (air-cooled and remote air-cooled models).....	61
L. Removal and Replacement of Water Valves.....	61
M. Removal and Replacement of Pump Motor.....	62
N. Removal and Replacement of Control Board.....	62
VI. Cleaning and Maintenance.....	63
A. Cleaning and Sanitizing Instructions.....	63
1. Cleaning Procedure.....	63
2. Sanitizing Procedure - Following Cleaning Procedure.....	65
B. Maintenance.....	66
C. Preparing the Icemaker for Long Storage.....	67

Important Safety Information

Throughout this manual, notices appear to bring your attention to situations which could result in death, serious injury, or damage to the unit.

⚠ WARNING Indicates a hazardous situation which could result in death or serious injury.

CAUTION Indicates a situation which could result in damage to the unit.

IMPORTANT Indicates important information about the use and care of the unit.

⚠ WARNING

This icemaker should be destined only to the use for which it has been expressly conceived. Any other use should be considered improper and therefore dangerous. The manufacturer cannot be held responsible for eventual damage caused by improper, incorrect, and unreasonable use.

To reduce the risk of death, electric shock, serious injury, or fire, follow basic precautions including the following:

- Electrical connection must be hard-wired and must meet national, state, and local electrical code requirements. Failure to meet these code requirements could result in death, electric shock, serious injury, fire, or severe damage to equipment.
- This unit requires an independent power supply. See the nameplate for proper voltage and breaker/fuse size. Failure to use a proper breaker or fuse can result in a tripped breaker, blown fuse, or damage to existing wiring. This could lead to heat generation or fire.
- **THIS UNIT MUST BE GROUNDED.** Failure to properly ground this unit could result in death or serious injury.
- This unit should be disassembled or repaired only by qualified service personnel to reduce the risk of electric shock, injury, or fire.
- Do not make any alterations to the unit. Alterations could result in electric shock, injury, fire, or damage to the unit.

I. Specifications

A. Ice maker

1. KMD-450MAH (air-cooled)

AC SUPPLY VOLTAGE	115-120/60/1 (3 wire with netrual for 115V)			
AMPERAGE	10.0 A (5 Min. Freeze AT 104°F / WT 80°F)			
MINIMUM CIRCUIT AMPACITY	15 A			
MAXIMUM FUSE SIZE	15 A			
APPROXIMATE ICE PRODUCTION PER 24 HR. lbs./day (kg/day) Reference without *marks	Ambient Temp.(°F)	WATER TEMP. (°F)		
		50	70	90
	70	*457 (207)	436 (198)	398 (180)
	80	441 (200)	409 (186)	365 (165)
	90	436 (198)	*387 (176)	344 (156)
	100	425 (193)	377 (171)	304 (138)
SHAPE OF ICE	Crescent Cube			
ICE PRODUCTION PER CYCLE	9.6 lbs. (4.3 kg) 432pcs.			
APPROXIMATE STORAGE CAPACITY	N/A			
ELECTRIC & WATER CONSUMPTION	90/70°F	70/50°F		
ELECTRIC W (kWH/100 lbs.)	880(5.48)	810(4.28)		
WATER gal./24HR (gal./100 lbs.)	73(18.9)	192(42.1)		
CEC/CEE TIER LEVEL	3			
ENERGY STAR	YES			
EXTERIOR DIMENSIONS (WxDxH)	30" x 24-1/4" x 22-1/8" (762 x 617 x 562 mm)			
EXTERIOR FINISH	Stainless Steel, Galvanized Steel (Rear)			
WEIGHT	Net 130 lbs. (59 kg), Shipping 170 lbs. (77 kg)			
CONNECTIONS - ELECTRIC	Permanent - Connection			
- WATER SUPPLY	Inlet	1/2" FPT		
- DRAIN	Outlet	3/4" FPT		
		5/8" OD Tube		
CUBE CONTROL SYSTEM	Float Switch			
HARVESTING CONTROL SYSTEM	Hot Gas and Water, Thermistor and Timer			
ICE MAKING WATER CONTROL	Timer Controlled. Overflow Pipe			
COOLING WATER CONTROL	N/A			
BIN CONTROL SYSTEM	Mechanical Lever Switch and Timer			
COMPRESSOR	Hermetic, Model RST45C1E-CAA-202			
CONDENSER	Air-Cooled , Fin and tube type			
EVAPORATOR	Vertical type, Stainless Steel and Copper			
REFRIGERANT CONTROL	Thermostatic Expansion Valve			
REFRIGERANT CHARGE	R404A, 1 lb. 5.2 oz. (600g)			
DESIGN PRESSURE	High 467PSIG, Low 230PSIG			
P.C. BOARD CIRCUIT PROTECTION	High Voltage Cut-out (Internal)			
COMPRESSOR PROTECTION	Auto-reset Overload Protector (Internal)			
REFRIGERANT CIRCUIT PROTECTION	Auto-reset High Pressure Control Switch			
LOW WATER PROTECTION	Float Switch			
ACCESSORIES -SUPPLIED	N/A			
-REQUIRED	Ice Dispenser or Ice Storage Bin			
OPERATING CONDITIONS	VOLTAGE RANGE	104 - 127 V		
	AMBIENT TEMP.	45 -100° F		
	WATER SUPPLY TEMP.	45 - 90° F		
	WATER SUPPLY PRESSURE	10 - 113 PSIG		

Note: We reserve the right to make changes in specifications and design without prior notice.

2. KMD-450MWH (water-cooled)

AC SUPPLY VOLTAGE	115-120/60/1 (3 wire with netrual for 115V)			
AMPERAGE	8.5A (5 Min. Freeze AT 104°F / WT 80°F)			
MINIMUM CIRCUIT AMPACITY	15 A			
MAXIMUM FUSE SIZE	15 A			
APPROXIMATE ICE PRODUCTION PER 24 HR.	Ambient Temp.(°F)	WATER TEMP. (°F)		
lbs./day (kg/day)		50	70	90
Reference without *marks	70	*460 (209)	447 (203)	415 (188)
	80	450 (204)	429 (195)	389 (177)
	90	447 (203)	*415 (188)	377 (171)
	100	436 (198)	406 (184)	343 (156)
SHAPE OF ICE	Crescent Cube			
ICE PRODUCTION PER CYCLE	9.3 lbs. (4.2 kg) 432pcs.			
APPROXIMATE STORAGE CAPACITY	N/A			
ELECTRIC & WATER CONSUMPTION	90/70°F	70/50°F		
ELECTRIC W (kWH/100 lbs.)	790(4.55)	790(4.14)		
WATER gal./24HR (gal./100 lbs.)	74(17.8)	145(31.6)		
WATER COOLED CONDENSER gal./24HR (gal./100 lbs.)	523(126)	315(68)		
CEC/CEE TIER LEVEL	3			
ENERGY STAR	N/A			
EXTERIOR DIMENSIONS (WxDxH)	30" x 24-1/4" x 22-1/8" (762 x 617 x 562 mm)			
EXTERIOR FINISH	Stainless Steel, Galvanized Steel (Rear)			
WEIGHT	Net 130 lbs. (59 kg), Shipping 170 lbs. (77 kg)			
CONNECTIONS - ELECTRIC	Permanent - Connection			
- WATER SUPPLY	Inlet	1/2" FPT	Cond. Inlet	1/2" FPT
- DRAIN	Outlet	3/4" FPT	Cond. Outlet	3/8" FPT
		5/8" OD Tube		
CUBE CONTROL SYSTEM	Float Switch			
HARVESTING CONTROL SYSTEM	Hot Gas and Water, Thermistor and Timer			
ICE MAKING WATER CONTROL	Timer Controlled. Overflow Pipe			
COOLING WATER CONTROL	Pressure Regulator			
BIN CONTROL SYSTEM	Mechanical Lever Switch and Timer			
COMPRESSOR	Hermetic, Model RST45C1E-CAA-202			
CONDENSER	Water-cooled, Tube in tube type			
EVAPORATOR	Vertical type, Stainless Steel and Copper			
REFRIGERANT CONTROL	Thermostatic Expansion Valve			
REFRIGERANT CHARGE	R404A, 1 lb. 0.9 oz. (480g)			
DESIGN PRESSURE	High 427PSIG, Low 230PSIG			
P.C. BOARD CIRCUIT PROTECTION	High Voltage Cut-out (Internal)			
COMPRESSOR PROTECTION	Auto-reset Overload Protector (Internal)			
REFRIGERANT CIRCUIT PROTECTION	Auto-reset High Pressure Control Switch			
LOW WATER PROTECTION	Float Switch			
ACCESSORIES -SUPPLIED	N/A			
-REQUIRED	Ice Dispenser or Ice Storage Bin			
OPERATING CONDITIONS	VOLTAGE RANGE	104 - 127 V		
	AMBIENT TEMP.	45 -100° F		
	WATER SUPPLY TEMP.	45 - 90° F		
	WATER SUPPLY PRESSURE	10 - 113 PSIG		

Note: We reserve the right to make changes in specifications and design without prior notice.

II. General Information

A. Construction

1. KMD-450MAH (air-cooled)

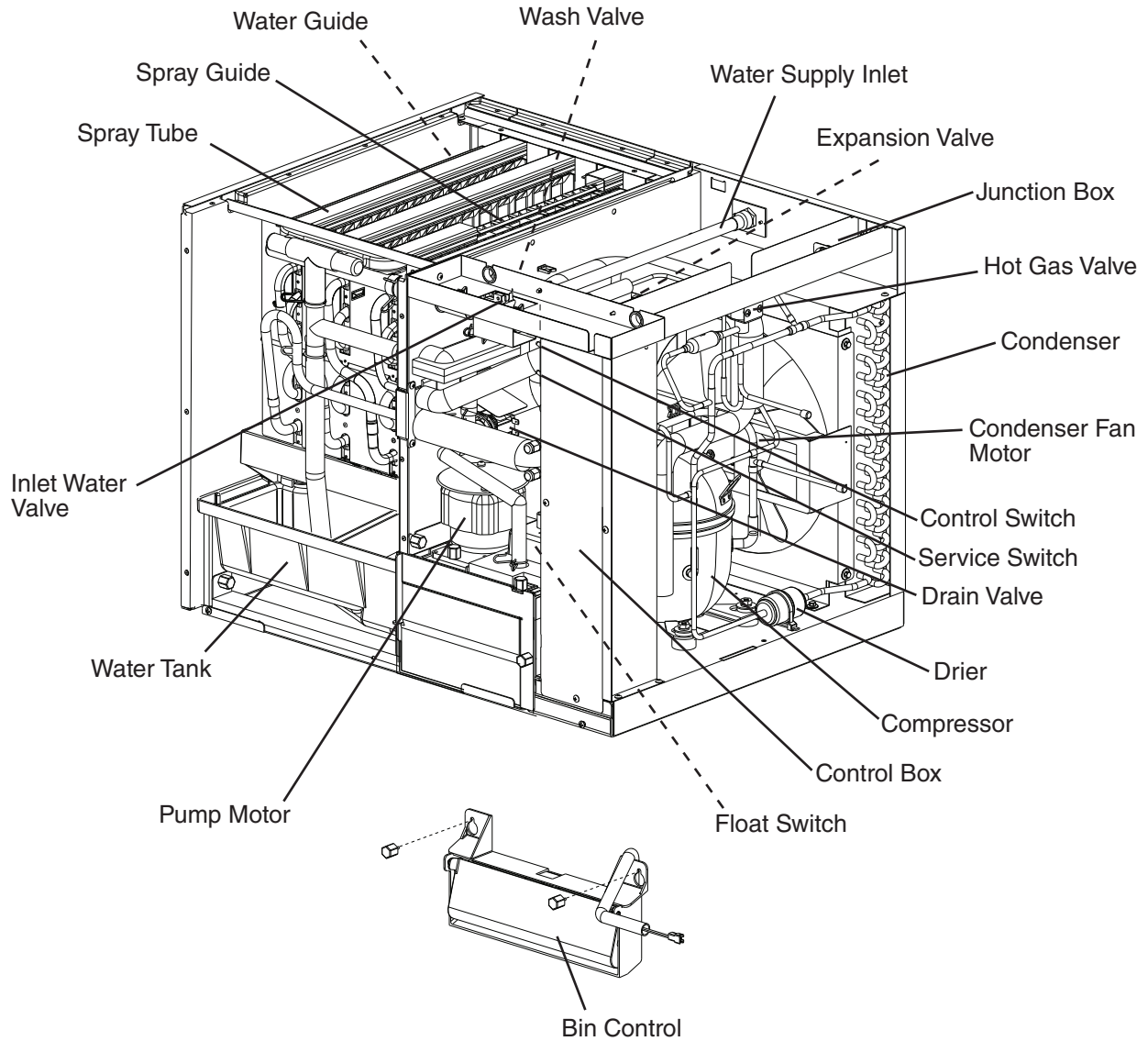

2. KMD-450MWH (water-cooled)

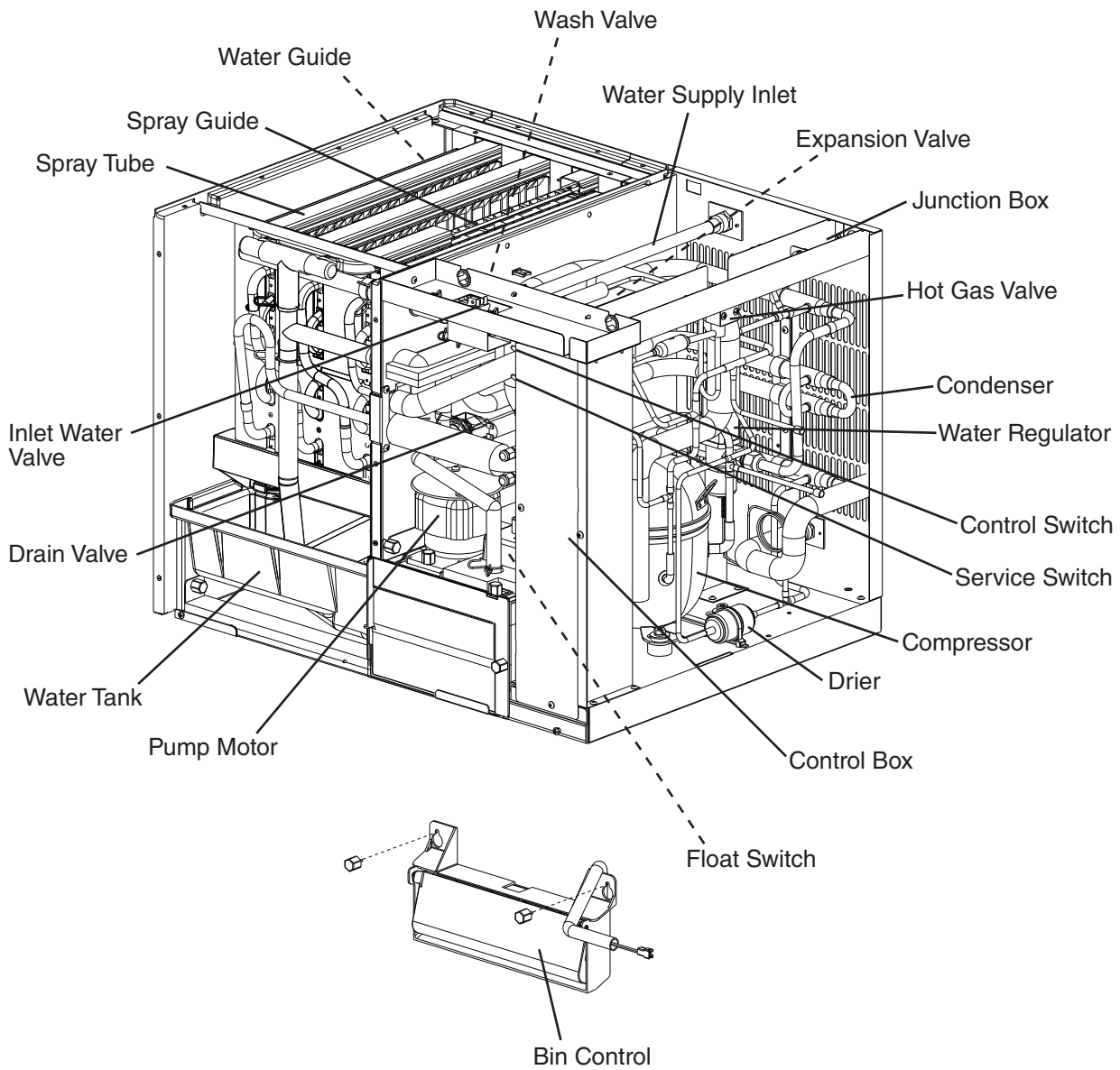

B. Sequence of Operation

1. Sequence Cycles and Shutdown

The steps in the sequence are as outlined below. When power is supplied, CB "POWER OK" LED comes on. There is a 5-second delay before startup. Note that the order of the component LEDs from the outer edge of CB is 5, 6, 8, 9, 4, 7.

a) 1-Minute Fill Cycle

LED 8 is on. WV energizes and the 1-minute fill cycle begins. After 1 minute, CB checks for a closed F/S. If F/S is closed, the harvest cycle begins. If not, WV remains energized through additional 1-minute fill cycles until water fills the tank and closes F/S. This serves as a low water safety to protect PM.

b) Initial Harvest Cycle

LEDs 5, 6, and 8 are on. WV remains energized, Comp, FMR, HGV energize. CB monitors the warming of the evaporator via the thermistor located on the suction line. When the thermistor reaches 48°F (9°C), CB reads a 3.9 kΩ signal from the thermistor and turns harvest termination over to the harvest timer (S1 dip switch 1 & 2). The harvest timer has settings of 60, 90, 120, and 180 seconds. For details, see "II.C.3.b) Harvest Timer (S1 dip switch 1 & 2)." WV is energized during harvest for a maximum of 6 minutes or the length of harvest minus 0, 10, 30, or 50 seconds (harvest pump timer (S1 dip switch 7 & 8)), whichever is shorter. For details, see "II.C.3.e) Harvest Pump Timer (S1 dip switch 7 & 8)." **LED 8 goes off** when WV de-energizes. **LED 7 comes on** and PM energizes and runs for the last 0, 10, 30, or 50 seconds of harvest depending on the harvest pump timer setting. This circulates water over the evaporator for the last 0, 10, 30, or 50 seconds of harvest. When the harvest timer expires, the harvest cycle is complete. CB checks the position of F/S and proceeds to the freeze cycle if it is closed or calls for a 1-minute fill cycle if it is open. The minimum total time allowed by CB for a complete harvest cycle is 2 minutes.

c) Freeze Cycle

LEDs 5 & 7 are on. Comp and FMR remain energized, PM energizes or remains energized depending on the harvest pump timer (S1 dip switch 7 & 8) setting. FM and LLV energize, HGV and WV (may de-energize during harvest cycle) de-energize. CB monitors the cooling of the evaporator via the thermistor located on the suction line. When the thermistor drops to 36°F (2°C), CB reads a 5.5 kΩ signal from the thermistor and starts a 5-minute short cycle protection timer. CB will not accept a signal from F/S until the 5-minute timer expires. After the 5-minute timer expires, F/S assumes control. As ice builds on the evaporator, the water level in the tank lowers. The freeze cycle continues until F/S opens and terminates the cycle.

The float switch selector (S2 dip switch 2) and the refill counter (S2 dip switch 3 & 4) allow certain models to use a double F/S to refill the water tank during the freeze cycle. The KMD-450MAH and KMD-450MWH use a single F/S and do not refill. For details, see "II.C.3.h) Float Switch Selector (S2 dip switch 2)" and "II.C.3.i) Refill Counter (S2 dip switch 3 & 4)." **CAUTION! Do not adjust S2 dip switch 2, 3, or 4 out of the factory default position on this model. These dip switches must be left in the factory default position or this unit will not operate correctly.**

The anti-slush control (S2 dip switch 6) helps prevent slushing during the freeze cycle on certain models. When activated, the control board monitors the cooling of the

evaporator via the thermistor located on the suction line. When the thermistor drops to 34°F (1°C), the control board reads a 5.8 kΩ signal from the thermistor and de-energizes PM for 10 seconds. The anti-slush control is deactivated on the KMD-450MAH and KMD-450MWH. **CAUTION! Do not adjust S2 dip switch 6 out of the factory default position on this model. This dip switch must be left in the factory default position or this unit will not operate correctly.**

d) Pump-Out Cycle

LEDs 5, 6, 4, and 7 are on. Comp and FMR remain energized, HGV energizes, LLV and FM de-energize. DV energizes after a 2-second delay. PM de-energizes for 2 seconds and then re-energizes, or de-energizes and stays off depending on the pump-out/drain selector (S2 dip switch 1) setting. For details, see "II.C.3.g) Pump-Out/Drain Selector (S2 dip switch 1)." When the pump-out/drain selector is set to pump-out, PM takes water from the tank and forces it through DV and down the drain. When the pump-out/drain selector is set to drain, water drains by gravity through DV. **CAUTION! Do not adjust S2 dip switch 1 out of the factory default position on this model. This dip switch must be left in the factory default position or this unit will not operate correctly.** Pump-out lasts 10 or 20 seconds depending on the pump-out timer (S1 dip switch 3 & 4) setting. When the pump-out timer expires, the pump-out is complete. For details, see "II.C.3.c) Pump-Out Timer (S1 dip switch 3 & 4)."

The first pump-out occurs after the 1st freeze cycle, then every 10th cycle thereafter. The pump-out frequency is factory set, and generally no adjustment is required. However, if the icemaker needs a pump-out more often due to local water conditions, the pump-out frequency can be adjusted. The pump-out frequency control (S1 dip switch 5 & 6) can be set to have a pump-out occur every cycle, or every 2, 5, or 10 cycles. For details, see "II.C.3.d) Pump-Out Frequency Control (S1 dip switch 5 & 6)."

e) Normal Harvest Cycle

Same as the initial harvest cycle. See "II.B.1.b) Initial Harvest Cycle."

Note: Unit continues to cycle until BC is satisfied or power is turned off. The unit always restarts at the 1-minute fill cycle.

f) Shutdown

When BC is activated (BC open), the "POWER OK" LED flashes. There is a delay before the shutdown sequence begins. The delay varies depending on the cycle the icemaker is in at the time of activation. For details, see the table below.

Cycle at Bin Control Activation	Delay Before Shutdown Sequence Begins
Fill Cycle	15 seconds
Harvest Cycle	15 seconds after the next freeze cycle starts
Freeze Cycle	15 seconds if BC is activated between the beginning of freeze and termination of the 5-minute short cycle protection timer (timer starts when the thermistor temperature drops to 36°F (2°C) (5.5 kΩ or more)). After this time, the unit will not shut down until the next harvest cycle is complete.

After the delay, all components de-energize. DV energizes after 2 seconds. PM energizes after 2 seconds or stays off depending on the pump-out/drain selector (S2 dip switch 1) setting. For details, see "II.C.3.g) Pump-Out/Drain Selector (S2 dip

switch 1)." When the pump-out/drain selector is set to pump-out, PM takes water from the tank and forces it through DV and down the drain. When the pump-out/drain selector is set to drain, water drains by gravity through DV. **CAUTION! Do not adjust S2 dip switch 1 out of the factory default position on this model. This dip switch must be left in the factory default position or this unit will not operate correctly.** The water tank drains for a maximum of 5 minutes or until F/S opens. DV and PM (if applicable) then de-energize. When BC closes again calling for ice, the unit starts at the 1-minute fill cycle. There is a 90-second minimum off time before the icemaker can restart.

Legend: **BC**—bin control; **CB**—control board; **Comp**—compressor; **DV**—drain valve; **FM**—fan motor; **FMR**—fan motor-remote; **F/S**—float switch; **HGV**—hot gas valve; **LLV**—liquid line valve; **PM**—pump motor; **WV**—inlet water valve

2. Sequence Flow Chart

"H" Control Board Sequence Flow Chart KMD-450MAH, KMD-450MWH

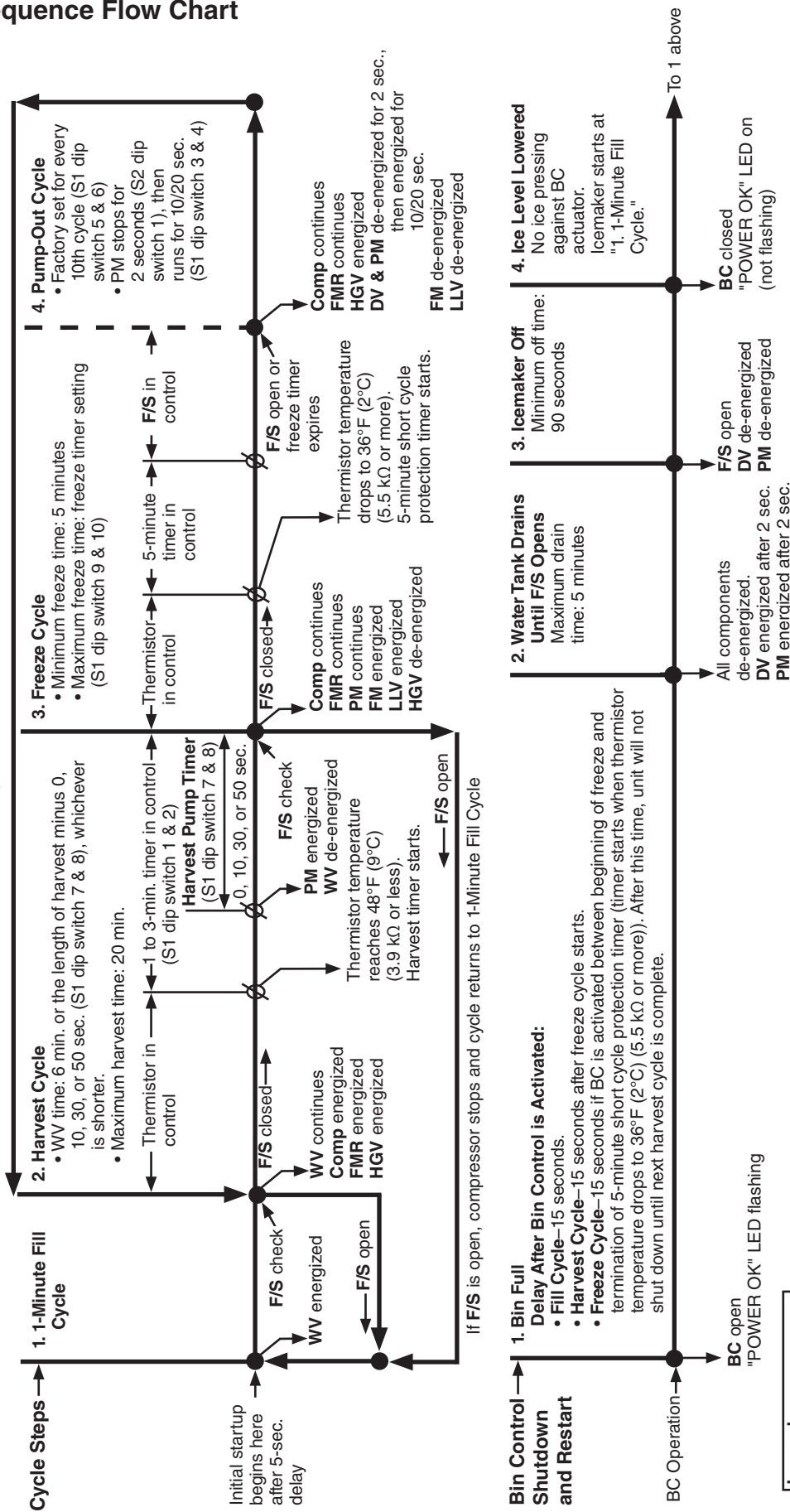

Components Energized when the Control Switch is in the "SERVICE" Position
 When in the "SERVICE" position, the control switch supplies power to the service switch and the icemaker is in service mode. The service switch has three positions: "DRAIN," "CIRCULATE," and "WASH." See the information below for details of each function.

DRAIN	Power is supplied to the pump motor and drain valve. This drains the water tank.
CIRCULATE	Power is supplied to the pump motor only. This can be used to circulate cleaner over the outside surface of the evaporator for extended periods of time.
WASH	Power is supplied to the pump motor and wash valve. This is used to circulate cleaner and sanitizer over both the inside and outside surfaces of the evaporator.

Legend:

- BC—bin control
- Comp—compressor
- DV—drain valve
- FM—fan motor
- FMR—fan motor-remote
- F/S—float switch
- HGV—hot gas valve
- LLV—liquid line valve
- PM—pump motor
- WV—inlet water valve

C. Control Board

- A Hoshizaki exclusive solid-state control board is employed in KMD-450MAH and KMD-450MWH Modular Crescent Cubers.
- All models are pretested and factory set.
- For a control board check procedure, see "IV.B. Control Board Check."

CAUTION

1. The control board is fragile; handle very carefully.
2. The control board contains integrated circuits, which are susceptible to failure due to static discharge. It is especially important to touch the metal part of the unit before handling or replacing the control board.
3. Do not touch the electronic devices on the control board or the back of the control board.
4. Do not change wiring and connections.
5. Always replace the whole control board assembly if it goes bad.
6. Do not short out power supply to test for voltage.

1. Control Board Layout

"H" Control Board

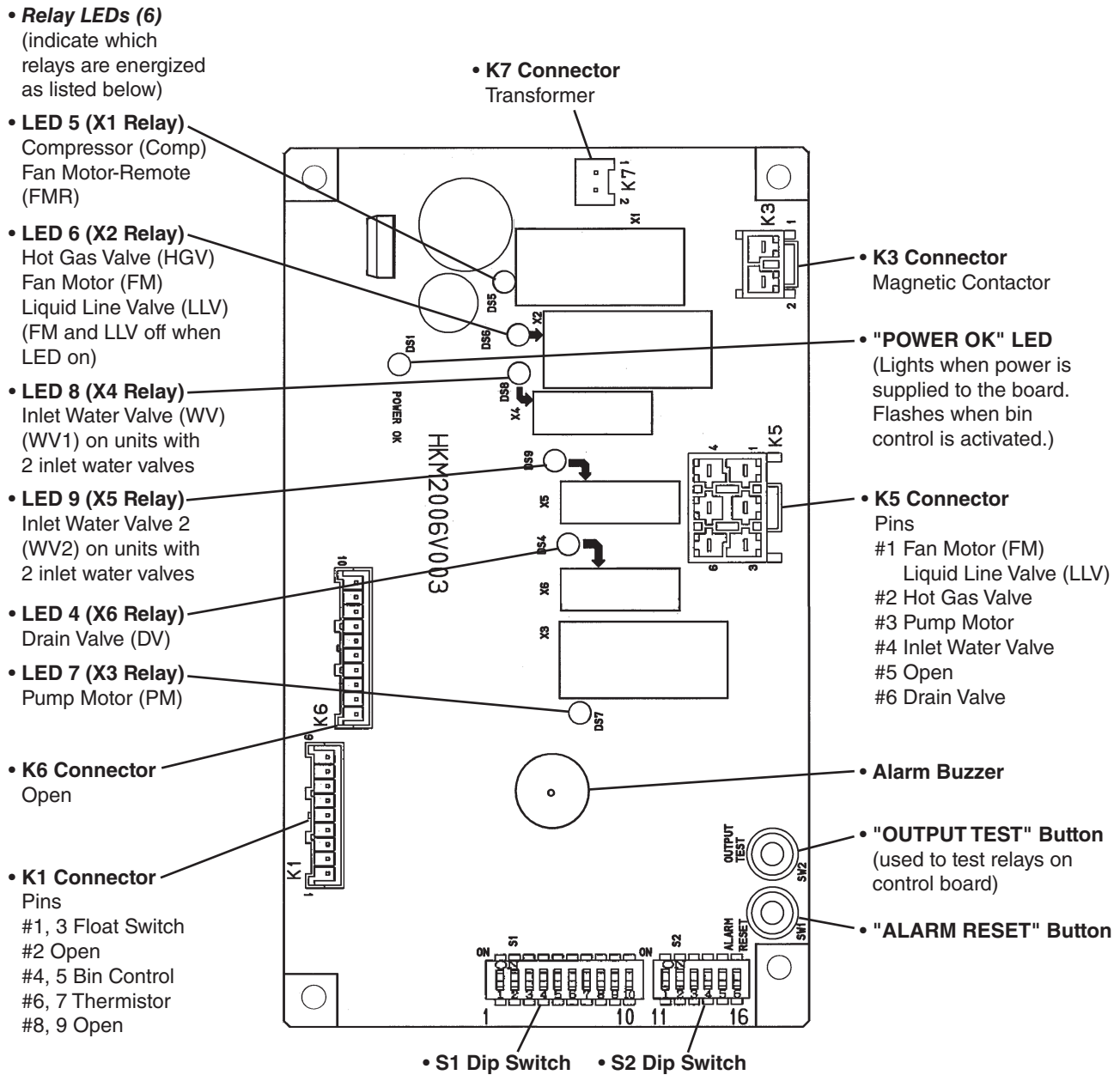

"H" Control Board	
Part Number	P00013-02

2. Features

a) Maximum Water Supply Period - 6 minutes

The inlet water valve is open during harvest for 6 minutes or the length of harvest minus 0, 10, 30, or 50 seconds (harvest pump timer (S1 dip switch 7 & 8)), whichever is shorter. For details, see "II.C.3.e) Harvest Pump Timer (S1 dip switch 7 & 8)."

b) Harvest Backup Timer and Freeze Timer

The harvest backup timer shuts down the icemaker if, for two cycles in a row, the harvest cycle takes more than 20 minutes to complete. The control board signals this problem using 2 beeps every 3 seconds.

The freeze timer shuts down the icemaker if, for two cycles in a row, the freeze cycle takes longer than the time specified to complete. The control board signals this problem using 3 beeps every 3 seconds. The time is factory set using S1 dip switch 9 & 10. For details, see "II.C.3.f) Freeze Timer (S1 dip switch 9 & 10)."

The "ALARM RESET" button on the control board must be pressed with power on to reset either of these safeties.

c) High Temperature Safety

The temperature of the suction line in the refrigeration circuit is limited by the high temperature safety. This protects the unit from excessively high temperatures. If the evaporator temperature reaches $127^{\circ}\text{F}\pm 7^{\circ}\text{F}$ ($53^{\circ}\text{C}\pm 4^{\circ}\text{C}$), the control board reads a .8 k Ω signal from the thermistor and shuts down the icemaker.

The control board will signal this problem using 1 beep every 3 seconds. The "ALARM RESET" button on the control board must be pressed with power on to reset the safety.

d) Low Water Safety

The control board checks the position of the float switch at the end of the initial 1-minute fill cycle and at the end of each harvest cycle. If the float switch is in the up position (electrical circuit closed), the control board changes to the next cycle. If the float switch is in the down position (electrical circuit open), the control board changes to additional 1-minute fill cycles until water fills the tank and closes the float switch. When the float switch closes, the control board changes to the next cycle. The unit will not start without adequate water in the tank. This serves as a low water safety to protect the water pump. For water-cooled model, if the condenser water supply is shut off, the unit is protected by the high-pressure switch.

e) High Voltage and Low Voltage Cut-outs

The maximum and minimum allowable supply voltages of this icemaker are limited by the high voltage and low voltage cut-outs. If miswiring (especially on single phase 3 wire models) causes excessive voltage ($147\text{Vac}\pm 5\%$ or more), the high voltage cut-out shuts down the circuit in 3 seconds and the icemaker automatically stops. The control board will signal this problem using 7 beeps every 3 seconds.

The icemaker also automatically stops in cases of insufficient voltage ($92\text{Vac}\pm 5\%$ or less). The control board signals this problem using 6 beeps every 3 seconds.

When the proper supply voltage is resumed, the icemaker automatically starts running again.

f) LED Lights and Audible Alarm Safeties

At startup, a 5-second delay occurs to stabilize the circuit. The "POWER OK" LED indicates proper control voltage and remains on unless a control voltage problem occurs. The "POWER OK" LED flashes continuously when the bin is full and PM and DV energize for a maximum of 5 minutes to drain the water tank. LEDs 4 through 9 energize and sequence from initial startup as listed in the table below. Note that the order of the LEDs from the outer edge of the control board is 5, 6, 8, 9, 4, 7. For details, see "II.B. Sequence of Operation."

Sequence Step	LED	Energized Components	Time LEDs are On		
			Min.	Max.	Avg.
1-Minute Fill Cycle	8	WV			1 minute
Harvest Cycle	5, 6, 8	Comp, FMR, HGV, WV	2 minutes	20 minutes	3 to 5 minutes
Harvest Pump Timer	5, 6, 7	Comp, FMR, HGV, PM	0 seconds	50 seconds	harvest pump timer setting
Freeze Cycle	5, 7	Comp, FM/FMR, PM, LLV	5 minutes	freeze timer setting	30 to 35 minutes
Pump-Out Cycle	5, 6, 4, 7*	Comp, FMR, HGV, DV, PM*	10 seconds	20 seconds	*pump-out/drain selector setting

The built-in safeties shut down the unit and have alarms as listed below.

No. of Beeps (every 3 sec.)	Type of Alarm	Notes
1	High Evaporator Temp. (temperature > 127°F) (53°C)	Check for harvest problem (stuck HGV or relay), hot water entering unit, stuck HM, or shorted thermistor.
2	Harvest Backup Timer (harvest > 20 min. for two cycles in a row)	Check for open thermistor, HGV not opening, TXV or LLV leaking by, low charge, inefficient Comp, or WRV leaking by.
3	Freeze Timer (freeze > freeze timer setting for two cycles in a row)	Check for F/S stuck closed (up), WV leaking by, HGV leaking by, PM not pumping, TXV not feeding properly, LLV not opening, low charge, HM not bypassing, or inefficient Comp.
To reset the above safeties, press the "ALARM RESET" button with the power supply on.		
6	Low Voltage (92Vac±5% or less)	"POWER OK" LED turns off if voltage protection operates.
7	High Voltage (147Vac±5% or more)	The control voltage safeties automatically reset when voltage is corrected.

Legend: **Comp**—compressor; **DV**—drain valve; **FM**—fan motor; **FMR**—fan motor-remote; **F/S**—float switch; **HGV**—hot gas valve; **HM**—headmaster (C.P.R.); **LLV**—liquid line valve; **PM**—pump motor; **TXV**—thermostatic expansion valve; **WRV**—water regulating valve; **WV**—inlet water valve

3. Controls and Adjustments

CAUTION

Dip switches are factory set. Failure to maintain factory settings may adversely affect performance and warranty coverage. For more information, contact Hoshizaki Technical Support at 1-800-233-1940.

a) **Default Dip Switch Settings**

The dip switches are factory set to the following positions:

S1 Dip Switch										
Dip Switch No.	1	2	3	4	5	6	7	8	9	10
KMD-450MAH	OFF	OFF	ON	ON	ON	ON	ON	ON	OFF	ON
KMD-450MWH	OFF	OFF	ON	ON	ON	ON	ON	ON	OFF	OFF

S2 Dip Switch (Do Not Adjust)						
Dip Switch No.	1	2	3	4	5	6
KMD-450MAH	ON	OFF	OFF	OFF	OFF	ON
KMD-450MWH	ON	OFF	OFF	OFF	OFF	ON

S1 Dip Switch

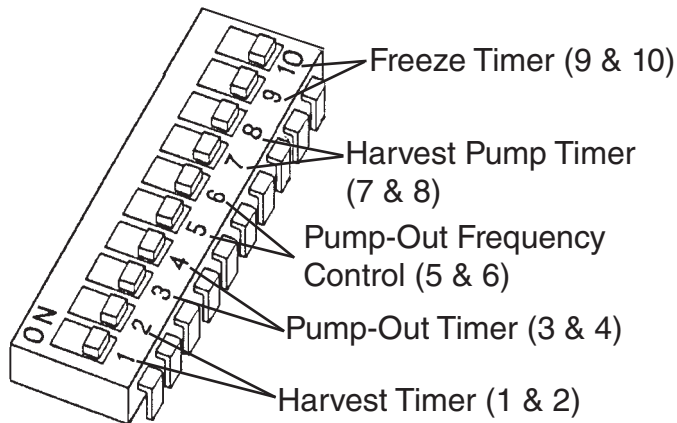

S2 Dip Switch

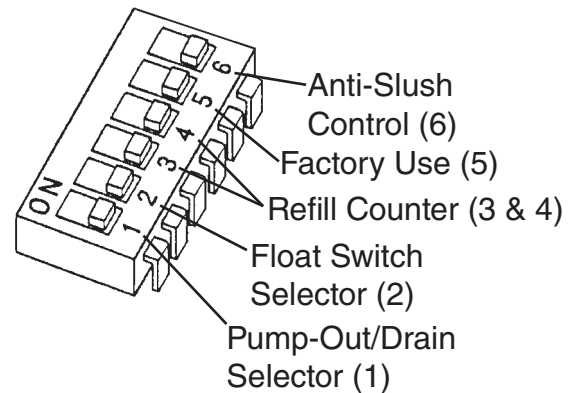

b) Harvest Timer (S1 dip switch 1 & 2)

The harvest timer starts when the thermistor reaches 48°F (9°C) at the evaporator outlet and the control board reads the thermistor's 3.9 kΩ signal. The harvest timer is factory set, and generally no adjustment is required. However, a setting longer than the factory setting may be advised in cases where the flush provided at harvest needs to be prolonged for extra cleaning. Before changing this setting, contact Hoshizaki Technical Support at 1-800-233-1940 for recommendations. Keep in mind that setting the harvest timer to a longer setting decreases 24-hour production.

Note that the pump-out timer (S1 dip switch 3 & 4) acts in place of the harvest timer during cycles with a pump-out. For details, see "II.C.3.c) Pump-Out Timer (S1 dip switch 3 & 4)."

S1 Dip Switch Setting		Time (seconds)
No. 1	No. 2	
OFF	OFF	60
ON	OFF	90
OFF	ON	120
ON	ON	180

c) Pump-Out Timer (S1 dip switch 3 & 4)

When a pump-out is called for, the pump motor de-energizes after the preceding freeze cycle. 2 seconds later, the pump motor and drain valve energize. The pump motor takes water from the tank and forces it through the drain valve and down the drain. The pump motor drains the water tank for the time determined by the pump-out timer. The pump-out timer also acts in place of the harvest timer during cycles with a pump-out. The pump-out timer is factory set, and generally no adjustment is required. However, if the default is 10 seconds and the icemaker needs a longer pump-out due to local water conditions, the pump-out timer can be adjusted to 20 seconds.

S1 Dip Switch Setting		Time (seconds)	
No. 3	No. 4	T1	T2
OFF	OFF	10	120
ON	OFF	10	180
OFF	ON	20	120
ON	ON	20	180

T1: Time to drain the water tank

T2: Harvest timer at pump-out

d) Pump-Out Frequency Control (S1 dip switch 5 & 6)

The pump-out frequency control is factory set to drain the water tank every 10 cycles, and generally no adjustment is required. However, if the icemaker needs a pump-out more often due to local water conditions, the pump-out frequency can be adjusted. The pump-out frequency control can be set to have a pump-out occur every cycle, or every 2, 5, or 10 cycles. After startup, the first pump-out occurs after the 1st freeze cycle.

S1 Dip Switch Setting		Frequency
No. 5	No. 6	
OFF	OFF	Every cycle
ON	OFF	Every 2 cycles
OFF	ON	Every 5 cycles
ON	ON	Every 10 cycles

e) Harvest Pump Timer (S1 dip switch 7 & 8)

CAUTION

Factory set for proper operation. Do not adjust. Adjustment outside of the factory default setting may result in damage to the icemaker.

Depending on the harvest pump timer setting, the pump motor energizes and runs for the last 0, 10, 30, or 50 seconds of harvest. When the pump motor is on, water circulates over the evaporator. The water valve is energized during harvest for a maximum of 6 minutes or the length of harvest minus 0, 10, 30, or 50 seconds (determined by the harvest pump timer setting), whichever is shorter.

S1 Dip Switch Setting		Time (seconds)
No. 7	No. 8	
OFF	OFF	0
ON	OFF	10
OFF	ON	30
ON	ON	50

f) Freeze Timer (S1 dip switch 9 & 10)

CAUTION

Adjust to proper specification, or the unit may not operate correctly.

The freeze timer setting determines the maximum allowed freeze time to prevent possible freeze-up issues. Upon termination of the freeze timer, the control board initiates the harvest cycle. After 2 consecutive freeze timer terminations, the control board shuts down the icemaker. In this case, see "IV.F.3. Low Ice Production" for possible solutions. The freeze timer is factory set, and generally no adjustment is required. Before changing this setting, contact Hoshizaki Technical Support at 1-800-233-1940 for recommendations.

S1 Dip Switch Setting		Time (minutes)
No. 9	No. 10	
ON	OFF	50
OFF	OFF	60
OFF	ON	70
ON	ON	100

g) Pump-Out/Drain Selector (S2 dip switch 1)

CAUTION

Factory set for proper operation. Do not adjust. Adjustment outside of the factory default setting may result in damage to the icemaker.

The pump-out/drain selector setting determines whether the pump motor energizes (pump-out) or stays off (drain) after a 2-second delay at the beginning of the pump-out cycle or at shutdown. Regardless of the pump-out/drain selector setting, the drain valve energizes after a 2-second delay at the beginning of the pump-out cycle or at shutdown. When the pump-out/drain selector is set to pump-out, the pump motor takes water from the tank and forces it through the drain valve and down the drain. When the pump-out/drain selector is set to drain, water drains by gravity through the drain valve.

S2 Dip Switch Setting	Pump-Out/ Drain
No. 1	
ON	Pump-Out
OFF	Drain

h) Float Switch Selector (S2 dip switch 2)

CAUTION

Do not adjust. This must be left in the factory default position or the unit will not operate correctly.

The float switch selector allows for single or double float switch applications. In double float switch applications, the float switch selector setting determines whether the lower or upper switch is used to initiate refills during the freeze cycle. The KMD-450MAH and KMD-450MWH use a single float switch and do not refill.

S2 Dip Switch Setting	Float Switch Type	Refill Initiation with Double Float Switch
No. 2		
OFF	Single or Double	Lower Switch
ON	Double	Upper Switch

i) Refill Counter (S2 dip switch 3 & 4)

CAUTION

Do not adjust. These must be left in the factory default position or the unit will not operate correctly.

Factory set. The refill counter determines the number of refills during the freeze cycle. The KMD-450MAH and KMD-450MWH do not refill.

j) Factory Use (S2 dip switch 5)

Must remain off.

k) Anti-Slush Control (S2 dip switch 6)

CAUTION

Do not adjust. This must be left in the factory default position or the unit will not operate correctly.

The anti-slush control helps prevent slushing during the freeze cycle on some models. It is deactivated on the KMD-450MAH and KMD-450MWH.

When activated, the control board monitors the cooling of the evaporator via the thermistor located on the suction line. When the thermistor drops to 34°F (1°C), the control board reads a 5.8 kΩ signal from the thermistor and de-energizes the pump motor for 10 seconds.

S2 Dip Switch Setting	Anti-Slush Control
No. 6	
OFF	Activated
ON	Deactivated

D. Bin Control

The mechanical bin control is a lever-actuated proximity switch used to control the level of ice in the dispenser unit/storage bin. There are 2 sets of mounting holes on the rear interior wall. For dispenser unit applications, the lower set of holes is recommended. When installed on a standard Hoshizaki storage bin, either set of holes is acceptable. See Fig. 1. The bin control should be mounted flush with the dispenser unit/storage bin wall.

The bin control is connected to the K1 nine-pin connector (pins 4 & 5) on the control board. When the actuator paddle is not engaged (bin control switch closed; "POWER OK" LED on), the unit produces ice. When the actuator paddle is engaged (bin control switch open; "POWER OK" LED flashing), the control board drains the water tank and then shuts down the unit. Note that there is a delay before the shutdown sequence begins. The delay varies depending on the cycle the icemaker is in at the time of activation. For details, see the table below.

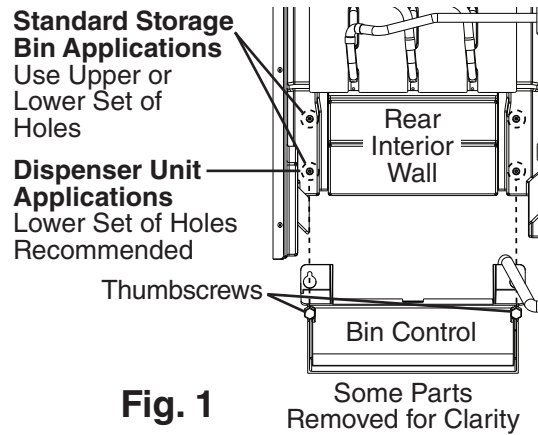

Fig. 1

Cycle at Bin Control Activation	Delay Before Shutdown Sequence Begins
Fill Cycle	15 seconds
Harvest Cycle	15 seconds after the next freeze cycle starts
Freeze Cycle	15 seconds if BC is activated between the beginning of freeze and termination of the 5-minute short cycle protection timer (timer starts when the thermistor temperature drops to 36°F (2°C) (5.5 kΩ or more)). After this time, the unit will not shut down until the next harvest cycle is complete.

For a bin control check procedure, see "IV.C.1. Bin Control Check."

E. Float Switch

The float switch is used to determine that there is sufficient water in the tank after the 1-minute fill cycle and after each harvest cycle. The float switch is also used to determine that the appropriate volume of water has been converted into ice before switching out of the freeze cycle. Finally, the float switch is used to determine that the water tank is empty during the drain that occurs as part of a bin-control activated shutdown. No adjustment is required.

For a float switch check procedure, see "IV.D.1. Float Switch Check."

F. Thermistor

The thermistor is used as a harvest control sensor, freeze cycle 5-minute short cycle protection timer sensor, and anti-slush sensor. The thermistor's resistance varies depending on the suction line temperature. The control board monitors the resistance to start the harvest timer, start the freeze cycle 5-minute short cycle protection timer, and momentarily stop the pump motor during the freeze cycle if the anti-slush control is activated. No adjustment is required.

For a thermistor check procedure, see "IV.E. Thermistor Check."

G. Switches

The "control switch" and the "service switch" are used to control operation and are located on the control box.

1. Control Switch

The control switch has three positions: "OFF" for power off, "ICE" for icemaking, and "SERVICE" to activate the service switch.

2. Service Switch

When the control switch is in the "SERVICE" position, the control switch supplies power to the service switch and the icemaker is in service mode. The service switch has three positions: "DRAIN," "CIRCULATE," and "WASH." See the information below for details of each function.

Note:

1. When the service switch is activated, power is supplied to the pump motor in all three positions.
2. When the control switch is in the "OFF" position or in the "ICE" position, the service switch has no power and can be left in any position.

a) DRAIN

When the service switch is active and in the "DRAIN" position, power is supplied to the pump motor and drain valve.

b) CIRCULATE

When the service switch is active and in the "CIRCULATE" position, power is supplied to the pump motor only. This operation can be used to circulate cleaner for extended periods of time over the outside surface of the evaporator.

c) WASH

When the service switch is active and in the "WASH" position, power is supplied to the pump motor and wash valve. This operation is used to circulate cleaner and sanitizer over both the inside and outside of the evaporator.

III. Technical Information

A. Water Circuit and Refrigeration Circuit

1. KMD-450MAH (air-cooled)

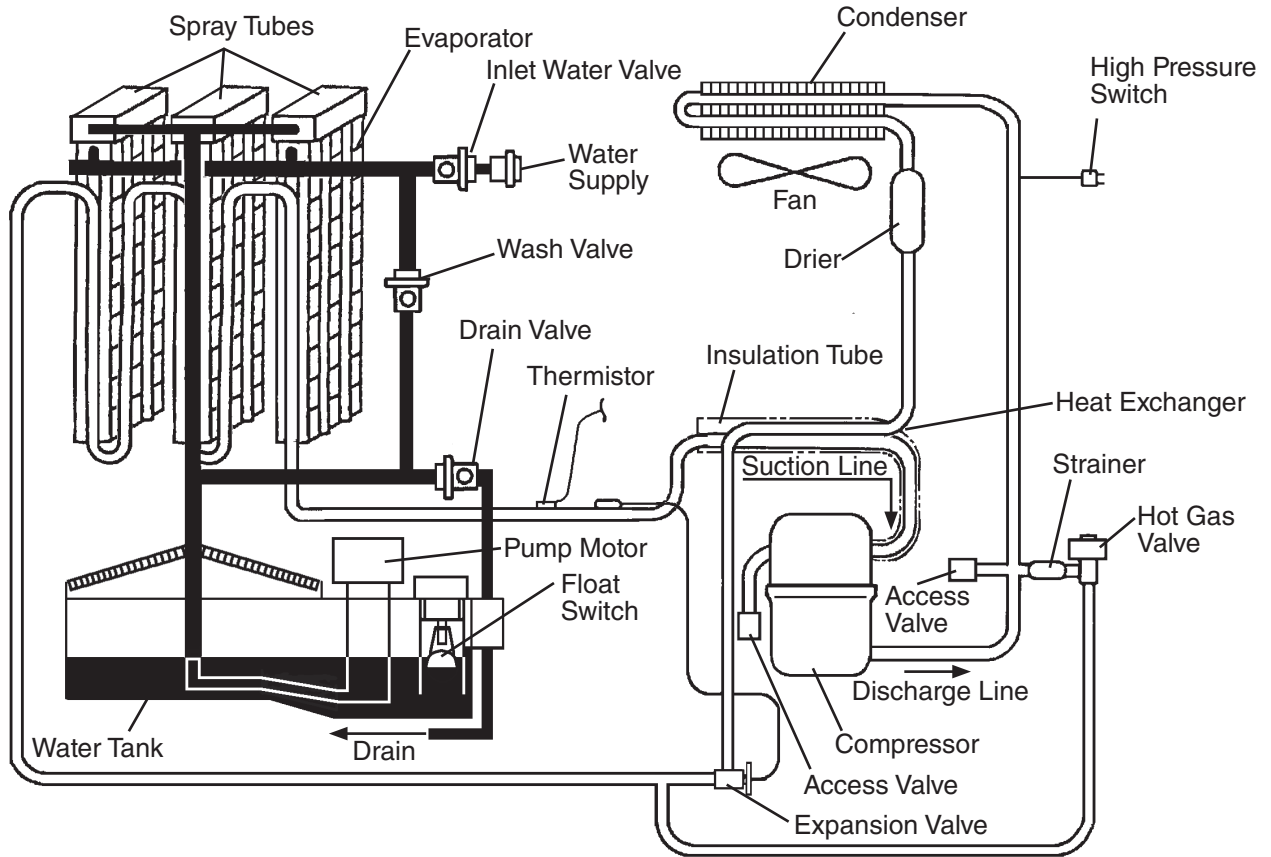

— Refrigeration Circuit
— Water Circuit

2. KMD-450MWH (water-cooled)

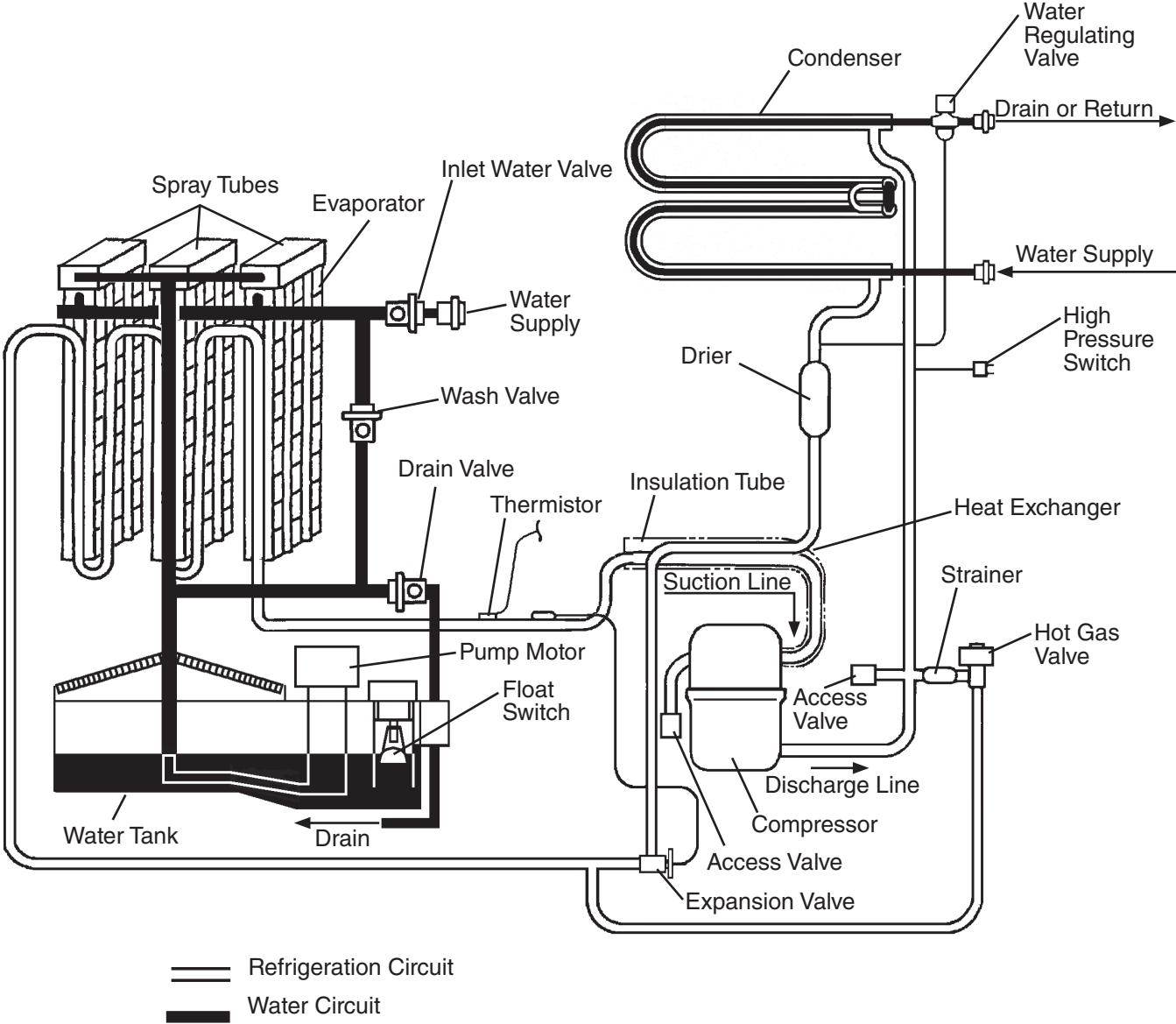

B. Wiring Diagram and Multimeter Access Points

1. Wiring Diagram

a) KMD-450MAH (air-cooled) and KMD-450MWH (water-cooled)

Note: A diagnostic connector and a compressor terminal block are included in the control box to allow easier access for a multimeter. For details see, "III.B.2. Multimeter Access Points."

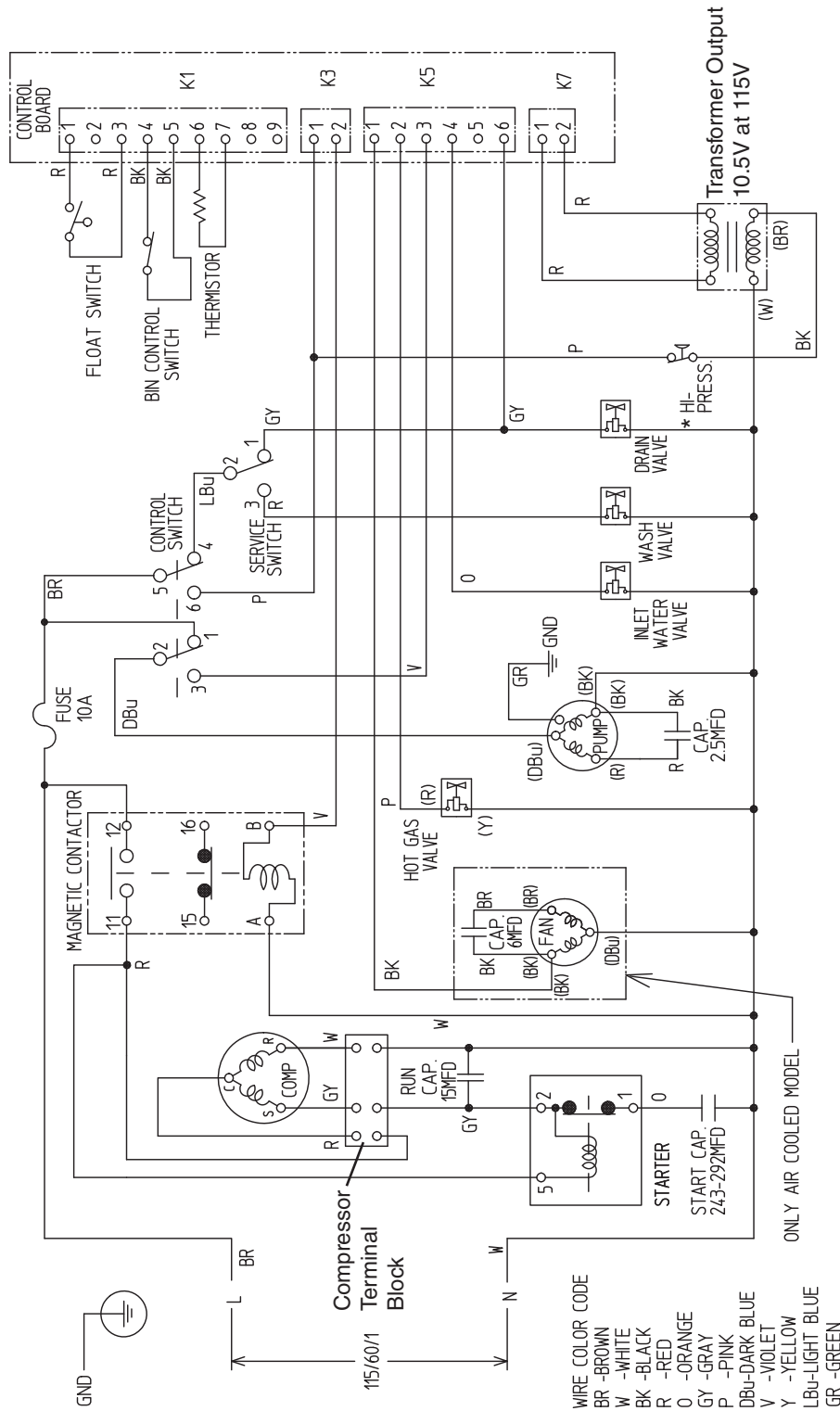

* High Pressure Switch		
Air-Cooled Model	Water-Cooled Model	
Cut-out	412 \pm 0 PSIG	384 \pm 0 PSIG
Cut-in	327 \pm 1.8 PSIG	284 \pm 1.8 PSIG

2. Multimeter Access Points

a) Diagnostic Connector

A diagnostic connector is included in the control box to allow easier access for a multimeter. The diagnostic connector terminals correspond to components as outlined in Fig. 2.

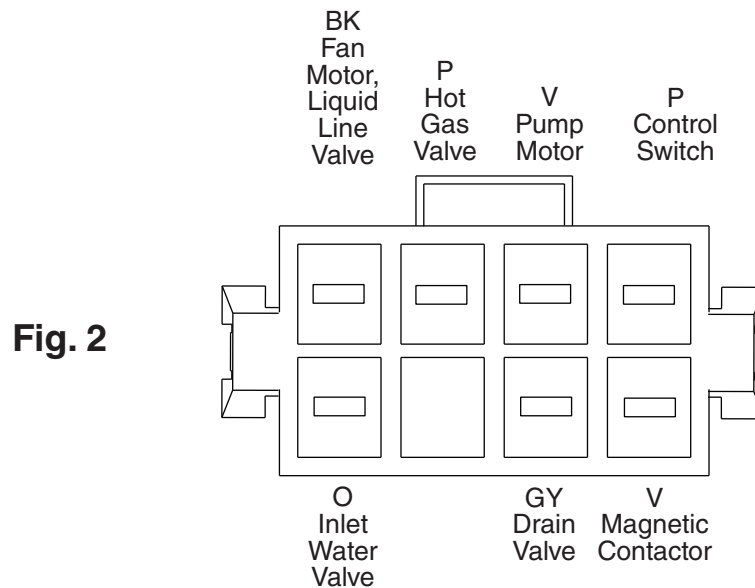

b) Compressor Terminal Block

A compressor terminal block is included in the control box to allow easier access for a multimeter. The terminal block terminals correspond to components as outlined in Fig. 3.

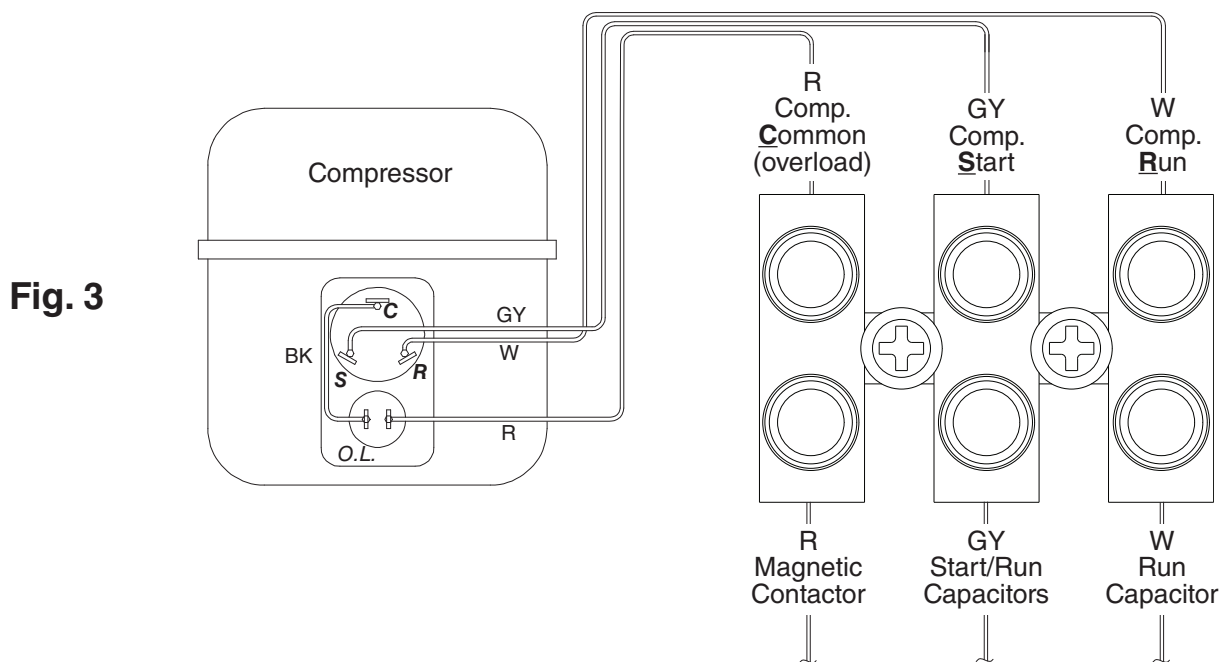

Wire Color Code: **BK**–black; **DBu**–dark blue; **GY**–gray; **O**–orange; **P**–pink; **R**–red;
V–violet; **W**–white

C. Performance Data

1. KMD-450MAH (air-cooled)

APPROXIMATE ICE PRODUCTION PER 24 HR.	AMBIENT TEMP. (°F/°C)	WATER TEMP. (°F/°C)					
		50/10		70/21		90/32	
	70/21	457	<u>207</u>	436	<u>198</u>	398	<u>180</u>
	80/27	441	<u>200</u>	409	<u>186</u>	365	<u>165</u>
	90/32	436	<u>198</u>	387	<u>176</u>	344	<u>156</u>
lbs./day <u>kg./day</u>	100/38	425	<u>193</u>	377	<u>171</u>	304	<u>138</u>
APPROXIMATE ELECTRIC CONSUMPTION	70/21	810		831		853	
	80/27	826		858		876	
	90/32	831		880		901	
watts	100/38	833		885		920	
APPROXIMATE WATER CONSUMPTION PER 24 HR.	70/21	192	<u>0.73</u>	157	<u>0.60</u>	139	<u>0.53</u>
	80/27	166	<u>0.63</u>	111	<u>0.42</u>	109	<u>0.41</u>
	90/32	157	<u>0.60</u>	73	<u>0.28</u>	64	<u>0.24</u>
gal./day <u>m³/day</u>	100/38	117	<u>0.44</u>	71	<u>0.27</u>	55	<u>0.21</u>
FREEZING CYCLE TIME	70/21	26		29		33	
	80/27	28		32		36	
	90/32	29		34		39	
min.	100/38	30		35		43	
HARVEST CYCLE TIME	70/21	3.6		3.1		3.0	
	80/27	3.2		2.5		2.6	
	90/32	3.1		2.0		2.0	
min.	100/38	2.6		2.0		2.0	
HEAD PRESSURE	70/21	245	<u>17.2</u>	264	<u>18.6</u>	288	<u>20.2</u>
	80/27	260	<u>18.2</u>	289	<u>20.3</u>	311	<u>21.9</u>
	90/32	264	<u>18.6</u>	310	<u>21.8</u>	333	<u>23.4</u>
PSIG <u>kg/cm²G</u>	100/38	268	<u>18.8</u>	315	<u>22.2</u>	355	<u>25.0</u>
SUCTION PRESSURE	70/21	53	<u>3.7</u>	55	<u>3.8</u>	56	<u>3.9</u>
	80/27	54	<u>3.8</u>	57	<u>4.0</u>	58	<u>4.1</u>
	90/32	55	<u>3.8</u>	59	<u>4.1</u>	60	<u>4.2</u>
PSIG <u>kg/cm²G</u>	100/38	55	<u>3.8</u>	59	<u>4.2</u>	61	<u>4.3</u>

TOTAL HEAT OF REJECTION FROM CONDENSER

7,700 BTU/h [AT 90°F (32°C) / WT 70°F (21°C)]

Note:

1. Pressure data is recorded at 5 minutes into freeze cycle. The data not in **bold** should be used for reference only.
2. We reserve the right to make changes in specifications and design without prior notice.

2. KMD-450MWH (water-cooled)

APPROXIMATE ICE PRODUCTION PER 24 HR.	AMBIENT TEMP. (°F/°C)	WATER TEMP. (°F/°C)					
		50/10		70/21		90/32	
	70/21	460	<u>209</u>	447	<u>203</u>	415	<u>188</u>
	80/27	450	<u>204</u>	429	<u>195</u>	389	<u>177</u>
	90/32	447	<u>203</u>	415	<u>188</u>	377	<u>171</u>
lbs./day <u>kg./day</u>	100/38	436	<u>198</u>	406	<u>184</u>	343	<u>156</u>
APPROXIMATE ELECTRIC CONSUMPTION	70/21	790		790		802	
	80/27	790		790		808	
	90/32	790		790		806	
watts	100/38	796		794		820	
APPROXIMATE WATER CONSUMPTION PER 24 HR.	70/21	460	<u>1.74</u>	500	<u>1.89</u>	683	<u>2.58</u>
	80/27	491	<u>1.86</u>	553	<u>2.09</u>	807	<u>3.05</u>
	90/32	500	<u>1.89</u>	597	<u>2.26</u>	824	<u>3.12</u>
gal./day <u>m³/day</u>	100/38	615	<u>2.33</u>	650	<u>2.46</u>	1033	<u>3.91</u>
FREEZING CYCLE TIME	70/21	28		28		30	
	80/27	28		29		32	
	90/32	28		30		33	
min.	100/38	29		31		35	
HARVEST CYCLE TIME	70/21	2.7		2.5		2.4	
	80/27	2.5		2.2		2.3	
	90/32	2.5		2.0		2.0	
min.	100/38	2.3		2.0		2.0	
HEAD PRESSURE	70/21	274	<u>19.3</u>	273	<u>19.2</u>	279	<u>19.6</u>
	80/27	274	<u>19.2</u>	273	<u>19.2</u>	281	<u>19.8</u>
	90/32	273	<u>19.2</u>	272	<u>19.1</u>	279	<u>19.6</u>
PSIG <u>kg/cm²G</u>	100/38	277	<u>19.4</u>	274	<u>19.2</u>	286	<u>20.1</u>
SUCTION PRESSURE	70/21	55	<u>3.9</u>	56	<u>3.9</u>	57	<u>4.0</u>
	80/27	55	<u>3.9</u>	56	<u>4.0</u>	57	<u>4.0</u>
	90/32	56	<u>3.9</u>	57	<u>4.0</u>	58	<u>4.1</u>
PSIG <u>kg/cm²G</u>	100/38	56	<u>3.9</u>	57	<u>4.0</u>	59	<u>4.1</u>

TOTAL HEAT OF REJECTION FROM CONDENSER	6,800 BTU/h [AT 90°F (32°C) / WT 70°F (21°C)]
TOTAL HEAT OF REJECTION FROM COMPRESSOR	1,100 BTU/h [AT 90°F (32°C) / WT 70°F (21°C)]
WATER FLOW FOR CONDENSER	40 gal./h [AT 100°F (38°C) / WT 90°F (32°C)]
PRESSURE DROP OF COOLING WATER LINE	less than 10 PSIG

Note:

1. Pressure data is recorded at 5 minutes into freeze cycle. The data not in **bold** should be used for reference only.
2. We reserve the right to make changes in specifications and design without prior notice.

IV. Service Diagnosis

⚠ WARNING

1. This unit should be diagnosed and repaired only by qualified service personnel to reduce the risk of death, electric shock, serious injury, or fire.
2. Risk of electric shock. Use extreme caution and exercise safe electrical practices.
3. Moving parts (e.g., fan blade) can crush and cut. Keep hands clear.
4. **CHOKING HAZARD:** Ensure all components, fasteners, and thumbscrews are securely in place after the unit is serviced. Make sure that none have fallen into the dispenser unit/storage bin.
5. Make sure all food zones in the icemaker and dispenser unit/storage bin are clean after the unit is serviced. For cleaning procedures, see "VI. Cleaning and Maintenance."

A. Diagnostic Procedure

The diagnostic procedure is basically a sequence check which can be used at unit startup or for system diagnosis. This procedure allows you to diagnose electrical system and component failures. Before conducting the diagnostic procedure, check for correct installation, proper voltage per unit nameplate, and adequate water supply. Check CB using the steps in "IV.B. Control Board Check." Check the dip switch settings to assure that S1 dip switch 3, 4, 7, 8, 9, & 10 and S2 dip switch 1 through 6 are in the factory default position. S1 dip switch 1, 2, 5, & 6 are cleaning adjustments and the settings are flexible. For factory default settings, see "II.C.3.a) Default Dip Switch Settings." As you go through the procedure, check to assure the components energize and de-energize correctly. If not, those components and controls are suspect. To check voltages coming from the board, a diagnostic connector is provided. For details, see "III.B.2. Diagnostic Connector." To check voltages going to the compressor, a compressor terminal block is provided. For details, see "III.B.3. Compressor Terminal Block."

- 1) Turn off the power supply, then access the control box. Clear any ice from BC.
- 2) Turn on the power supply, then move the control switch to the "ICE" position. A 5-second delay occurs. The "POWER OK" LED on CB comes on. If the "POWER OK" LED is flashing (indicating a full bin), check BC. See "IV.C.1. Bin Control Check."

⚠ WARNING

1. Risk of electric shock. Use extreme caution and exercise safe electrical practices.
2. Moving parts (e.g., fan blade) can crush and cut. Keep hands clear.

- 3) **1-Minute Fill Cycle – LED 8 is on.** WV energizes. After 1 minute, CB checks for a closed F/S. If F/S is closed, the harvest cycle begins. If closed, continue to step 4. If open, WV remains energized through additional 1-minute fill cycles until water fills the tank and closes F/S (low water safety). **Diagnosis:** If WV does not open, check the supply voltage at WV terminals, check continuity on the coil, confirm the screen or external filter is not plugged (no water flow). If unit fails to start harvest, check for open

F/S or bad 1-minute timer in CB. See "IV.D. Float Switch Check and Cleaning" and "IV. B. Control Board Check."

4) **Initial Harvest Cycle – LEDs 5, 6, and 8 are on.** WV remains energized, the contactor coil energizes to energize Comp and FMR, and HGV energizes. CB monitors the warming of the evaporator via the thermistor located on the suction line. When the thermistor reaches 48°F (9°C), CB reads a 3.9 kΩ signal from the thermistor and turns harvest termination over to the harvest timer (S1 dip switch 1 & 2). The harvest timer has settings of 60, 90, 120, and 180 seconds. For details, see "II.C.3.b) Harvest Timer (S1 dip switch 1 & 2)." WV is energized during harvest for a maximum of 6 minutes or the length of harvest minus 0, 10, 30, or 50 seconds (harvest pump timer (S1 dip switch 7 & 8)), whichever is shorter. For details, see "II.C.3.e) Harvest Pump Timer (S1 dip switch 7 & 8)." **LED 8 goes off** when WV de-energizes. **LED 7 comes on** and PM energizes and runs for the last 0, 10, 30, or 50 seconds of harvest depending on the harvest pump timer setting. This circulates water over the evaporator for the last 0, 10, 30, or 50 seconds of harvest. When the harvest timer expires, the harvest cycle is complete. CB checks the position of F/S and proceeds to the freeze cycle if it is closed or calls for a 1-minute fill cycle if it is open. The minimum total time allowed by CB for a complete harvest cycle is 2 minutes. **Diagnosis:** Check if Comp is running, HGV and WV still energized. Average harvest cycle at factory setting is 2 to 3 minutes. How long does initial harvest last? 1.5 minutes after initial harvest begins, touch Comp discharge line. Is it hot? If not, check refrigerant pressures and Comp operation. If it is hot, touch the inlet line to the evaporator. Is it hot? If it is hot and PM does not run per the harvest timer setting and/or the freeze cycle does not start, check the harvest timer, the thermistor for open circuit, the discharge line temperature, PM circuit and capacitor, PM terminal on the diagnostic connector (violet wire) for voltage, Comp efficiency, and if HGV is fully open. For a thermistor check (including harvest timer check), see "IV.E. Thermistor Check." For diagnostic connector details, see "III.B.2. Diagnostic Connector."

5) **Freeze Cycle – LEDs 5 and 7 are on.** Comp and FMR remain energized, PM, LLV, and FM energize. WV and HGV de-energize. CB monitors the cooling of the evaporator via the thermistor located on the suction line. When the thermistor drops to 36°F (2°C), CB reads a 5.5 kΩ signal from the thermistor and starts a 5-minute short cycle protection timer. After the 5-minute short cycle protection timer expires, CB turns freeze termination over to F/S.

The float switch selector (S2 dip switch 2) and the refill counter (S2 dip switch 3 & 4) allow certain models to use a double F/S to refill the water tank during the freeze cycle. The KMD-450MAH and KMD-450MWH use a single F/S and do not refill. For details, see "II.C.3.h) Float Switch Selector (S2 dip switch 2)" and "II.C.3.i) Refill Counter (S2 dip switch 3 & 4)." **CAUTION! Do not adjust S2 dip switch 2, 3, or 4 out of the factory default position on this model. These dip switches must be left in the factory default position or this unit will not operate correctly.**

The anti-slush control (S2 dip switch 6) helps prevent slushing during the freeze cycle on certain models. When activated, the control board monitors the cooling of the evaporator via the thermistor located on the suction line. When the thermistor drops to 34°F (1°C), the control board reads a 5.8 kΩ signal from the thermistor

and de-energizes PM for 10 seconds. The anti-slush control is deactivated on the KMD-450MAH and KMD-450MWH. **CAUTION! Do not adjust S2 dip switch 6 out of the factory default position on this model. This dip switch must be left in the factory default position or this unit will not operate correctly.**

Diagnosis: During the first 5 minutes of freeze, confirm that the evaporator temperature drops. If the evaporator is not cold, check to see if HGV is still open or if TXV is not opening properly, if WV is continuing to fill the reservoir, if there are improper unit pressures, an inoperative Comp, or an inoperative HM. Place a thermometer on the suction line next to the thermistor. When the temperature drops to 36°F (2°C), disconnect F/S (black and red wires) at the 3-pin connector on the control box. See Fig. 4. After approximately 5 minutes, the short cycle protection timer expires and the unit should switch out of the freeze cycle. If the unit switches out of freeze with F/S removed, but would previously not switch out of freeze with F/S connected (long freeze - 3 beep alarm), F/S may be sticking. To check and clean F/S, see "IV.D. Float Switch Check and Cleaning." If the unit remains in freeze with F/S removed, check the thermistor for loose attachment or out of spec. For a thermistor check, see "IV.E. Thermistor Check." If the unit remains in freeze with F/S removed and the thermistor is properly attached and within spec, replace CB. See "V.N. Removal and Replacement of Control Board."

Note: Normal freeze cycle will last 20 to 40 minutes depending on model and conditions. Cycle times and pressures should follow performance data provided in this manual. See "III.C. Performance Data."

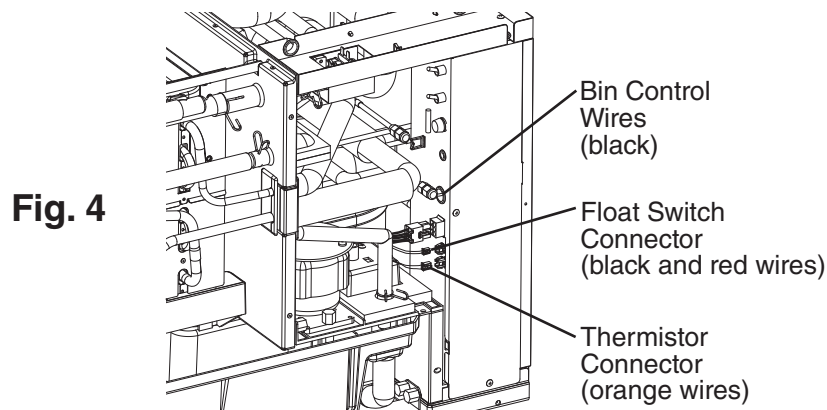

6) **Pump-Out Cycle – (10/20 second pump-out) – LEDs 5, 6, 4, and 7 are on.** Comp and FMR remain energized, HGV energizes, LLV and FM de-energize. DV energizes after a 2-second delay. PM de-energizes for 2 seconds and then re-energizes, or de-energizes and stays off depending on the pump-out/drain selector (S2 dip switch 1) setting. For details, see "II.C.3.g) Pump-Out/Drain Selector (S2 dip switch 1)." When the pump-out/drain selector is set to pump-out, PM takes water from the tank and forces it through DV and down the drain. When the pump-out/drain selector is set to drain, water drains by gravity through DV. **CAUTION! Do not adjust S2 dip switch 1 out of the factory default position on this model. This dip switch must be left in the factory default position or this unit will not operate correctly.** Pump-out lasts 10 or 20 seconds depending on the pump-out timer (S1 dip switch 3 & 4) setting. When the pump-out timer expires, the pump-out is complete. For details, see "II.C.3.c) Pump-Out Timer (S1 dip switch 3 & 4)."

The first pump-out occurs after the 1st freeze cycle, then every 10th cycle thereafter. The pump-out frequency is factory set, and generally no adjustment is required. However, if the icemaker needs a pump-out more often due to local water conditions, the pump-out frequency can be adjusted. The pump-out frequency control (S1 dip switch 5 & 6) can be set to have a pump-out occur every cycle, or every 2, 5, or 10 cycles. For details, see "II.C.3.d) Pump-Out Frequency Control (S1 dip switch 5 & 6)." **Diagnosis:** If PM does not run, check to see if pump-out/drain selector (S2 dip switch 1) setting is in the factory default position. Check PM circuit and capacitor, and PM terminal on the diagnostic connector (violet wire) for voltage. For diagnostic connector details, see "III.B.2. Diagnostic Connector." If DV does not open, check the supply voltage at DV terminals, and check continuity on the coil. If water does not pump-out, check and clean the tubing at DV, then check and clean DV assembly.

- 7) **Normal Harvest Cycle** – same as the initial harvest cycle – See "IV.A.4) Initial Harvest Cycle."
- 8) **Shutdown** – See "IV.C.1. Bin Control Check." Note that after a bin-control initiated shutdown, there is a 90 second minimum off time.

Legend: **BC**–bin control; **CB**–control board; **Comp**–compressor; **DV**–drain valve; **FM**–fan motor; **FMR**–fan motor-remote; **F/S**–float switch; **HGV**–hot gas valve; **HM**–headmaster (C.P.R.); **LLV**–liquid line valve; **PM**–pump motor; **TXV**–thermostatic expansion valve; **WV**–inlet water valve

B. Control Board Check

Before replacing a control board that does not show a visible defect and that you suspect is bad, always conduct the following check procedure. This procedure will help you verify your diagnosis.

Alarm Reset: If the control board is in alarm (beeping), press the "ALARM RESET" button on the control board with power on. Once reset, the unit starts at the 1-minute fill cycle. For audible alarm information, see "II.C.2.f) LED Lights and Audible Alarm Safeties."

- 1) Check the dip switch settings to assure that S1 dip switch 3, 4, 7, 8, 9, & 10 and S2 dip switch 1 through 6 are in the factory default position. S1 dip switch 1, 2, 5, & 6 are cleaning adjustments and the settings are flexible. For factory default settings, see "II.C.3.a) Default Dip Switch Settings."
- 2) Move the control switch to the "ICE" position. If the "POWER OK" LED is on (or flashing if the bin is full), the control voltage is good. If the "POWER OK" LED is off, check the control transformer secondary circuit. Transformer output is 10.5V at 115V primary input. If the secondary circuit has proper voltage and the "POWER OK" LED is off, the control board is bad and should be replaced. See "V.N. Removal and Replacement of Control Board."

If the secondary circuit does not have proper voltage, check the control transformer primary circuit. Check the control switch wire (pink) on the diagnostic connector to a white neutral wire for 115V. For location of the control switch wire, see "III.B.2. Diagnostic Connector." Always choose a white neutral wire to establish a good neutral connection when checking voltages. For additional checks, see "IV.F.1.[1] The icemaker will not start."

- 3) The "OUTPUT TEST" button provides a relay sequence test. Move the control switch to the "OFF" position. While pressing the "OUTPUT TEST" button, move the control switch back to the "ICE" position. The correct LED lighting sequence is 5, 6, 7, 8, 9, 4. Note that the order of the LEDs from the outer edge of the board is 5, 6, 8, 9, 4, 7. Components (e.g., compressor) cycle during the test. Each LED stays on for 5 seconds. LED 5 stays on while LED 6 is on. The "POWER OK" LED flashes once when the first relay LED turns on, twice when the second relay LED turns on, and adds one flash for each LED thereafter. A beep also sounds as each LED turns on. Following the test, the icemaker resumes operation. If the LEDs do not light as described above, the control board is bad and should be replaced. See "V.N. Removal and Replacement of Control Board."
- 4) Utilize the diagnostic connector to verify voltage output from the control board to the components. For diagnostic connector details, see "III.B.2. Diagnostic Connector." With the unit in the cycle to be tested, check output voltage from the corresponding terminal on the diagnostic connector to ground. If output voltage is not found and the appropriate LED is on, the control board is bad and should be replaced. See "V.N. Removal and Replacement of Control Board."

C. Bin Control Check and Cleaning

1. Bin Control Check

To check the bin control, follow the steps below.

- 1) Turn off the power supply.
- 2) Remove the front panel, then move the control switch to the "OFF" position.
- 3) Remove the control box cover, then clear any ice away from the bin control.
- 4) Disconnect the wire connector from the control board K1 nine-pin connector. See "II. C.1. Control Board Layout."
- 5) Check for continuity across the black wires (4 & 5) of the wire connector. When the actuator paddle is not engaged, the lever-actuated bin control switch is closed. If the lever-actuated bin control switch reads open, check that the harness connector is secured to the bin control switch connector and that the actuator paddle is not sticking. See Fig. 5. Clean if necessary. See "IV.C.2.b) Bin Control Cleaning." If the bin control switch still reads open, replace the bin control.
- 6) Press the actuator paddle, check for continuity across the black wires (4 & 5) of the wire connector. When the actuator paddle is engaged, the lever-actuated bin control switch is open. If closed, check that the actuator paddle is not restricted. Clean if necessary. See "IV.C.2.b) Mechanical Bin Control Cleaning." If the bin control switch still reads closed, replace the bin control.
- 7) Reconnect the wire connector to the control board K1 nine-pin connector, then move the control switch to the "ICE" position. Turn on the power supply.
- 8) Check that the "POWER OK" LED on the control board is on (not flashing).
- 9) During the 1-minute fill cycle, press the actuator in and hold it in for 15 seconds. Check that the "POWER OK" LED flashes and, after the actuator is held in for 15 seconds, the water tank drains. After the water tank drains and the float switch opens, the unit should shut down. If the unit does not shut down after the water tank drains, check the float switch. See "IV.D. Float Switch Check and Cleaning." If the float switch checks out and the unit will not shut down after the water tank drains, replace the control board. See "V.N. Removal and Replacement of Control Board."

2. Bin Control Cleaning

Scale may build up on the bin control. Scale can cause the actuator paddle to stick. In this case, the bin control should be cleaned.

WARNING

CHOKING HAZARD: Ensure all components, fasteners, and thumbscrews are securely in place after the unit is serviced. Make sure that none have fallen into the storage bin.

- 1) Turn off the power supply.
- 2) Remove the front panel, then move the control switch to the "OFF" position.
- 3) Clear any ice away from the bin control.

- 4) Disconnect the harness connector from the bin control switch connector, then remove the bin control from the unit.
- 5) Remove the actuator paddle from the switch mount. See Fig. 5.
- 6) Wipe down the bin control with a mixture of 1 part recommended cleaner Hoshizaki "Scale Away" and 25 parts warm water. Rinse the parts thoroughly with clean water.
- 7) Reassemble the bin control and replace it in its correct position.
- 8) Reconnect the harness connector.
- 9) Move the control switch to the "ICE" position.
- 10) Replace the front panel in its correct position.
- 11) Turn on the power supply to start the automatic icemaking process.

D. Float Switch Check and Cleaning

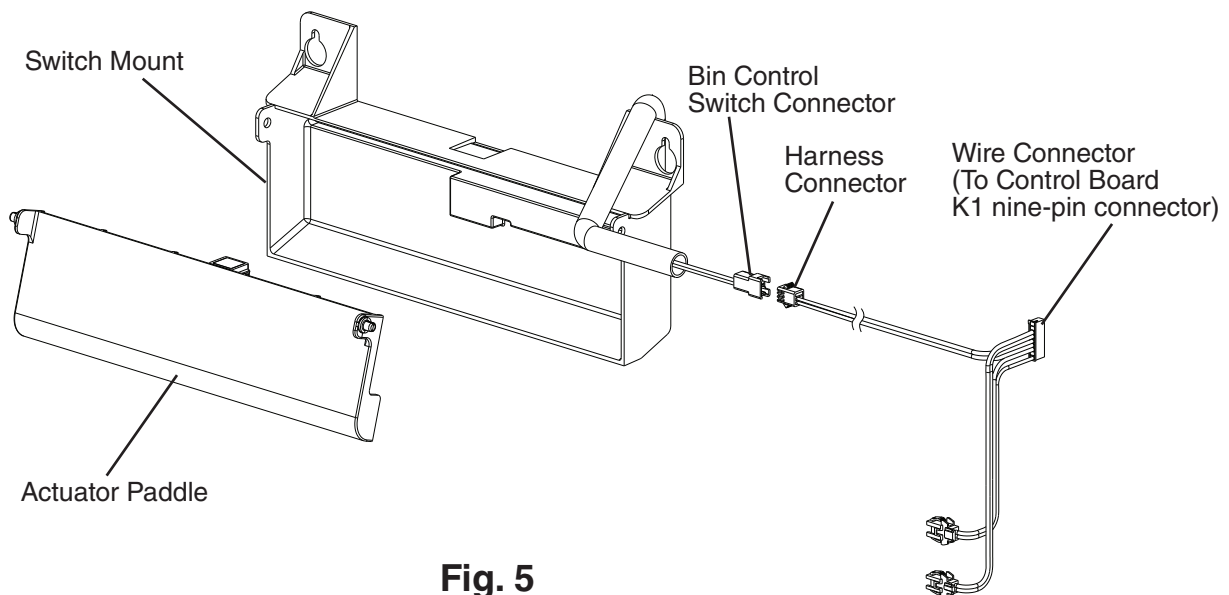

Fig. 5

1. Float Switch Check

To check the float switch, follow the steps below.

- 1) Remove the front panel and move the control switch to the "SERVICE" position. Move the service switch to the "DRAIN" position.
- 2) Allow the water to drain from the tank, then move the control switch to the "OFF" position.
- 3) Turn off the power supply.
- 4) Disconnect the wire connector from the control board K1 nine-pin connector. See "II. C.1. Control Board Layout."
- 5) Check for continuity across the red wires (1 & 3) of the wire connector. With the water tank empty, the float switch is open. If open, continue to step 6. If closed, follow the steps in "IV.D.2. Float Switch Cleaning." After cleaning the float switch, check it again. Replace if necessary.

- 6) Reconnect the wire connector to the control board K1 nine-pin connector, then replace the control box cover in its correct position.
- 7) Move the control switch to the "ICE" position. Replace the front panel in its correct position, then turn on the power supply. After 1 minute, the 1-minute fill cycle should end and the initial harvest cycle should begin. If the initial harvest cycle begins, the float switch is good and the check is complete. If the initial harvest cycle does not begin, continue to step 8.
- 8) Turn off the power supply.
- 9) Remove the front panel.
- 10) Move the control switch to the "OFF" position.
- 11) Remove the control box cover.
- 12) Disconnect the wire connector from the control board K1 nine-pin connector.
- 13) Check for continuity across the red wires (1 & 3) of the wire connector. With the water tank full, the float switch is closed. If the float switch is closed and the icemaker will not switch from the 1-minute fill cycle to the initial harvest cycle, replace the control board. See "V.N. Removal and Replacement of Control Board."

If the float switch is open, confirm that the float switch connection on the side of the control box is secure and that the water tank is full. If the tank is not full, check the water supply, water filters, and inlet water valve. If the tank is full, follow the steps in "IV.D.2. Float Switch Cleaning." After cleaning the float switch, check it again. Replace if necessary.

2. Float Switch Cleaning

Depending on local water conditions, scale may build up on the float switch. Scale on the switch can cause the float to stick. In this case, the float switch should be cleaned.

- 1) If you have not already done so, remove the front panel and move the control switch to the "SERVICE" position. Move the service switch to the "DRAIN" position. Allow the water to drain from the tank, then move the control switch to the "OFF" position.
- 2) Turn off the power supply.
- 3) Remove insulation panel (A) (the large insulation panel in front of the evaporator) by lifting up the panel slightly and pulling it towards you.
- 4) Remove the 2 thumbscrews securing insulation panel (B), then remove insulation panel (B). See Fig. 6.
- 5) Disconnect the discharge hose, the drain valve drain hose, and the overflow drain hose.
- 6) Disconnect the pump motor connector and the float switch connector from the side of the control box.

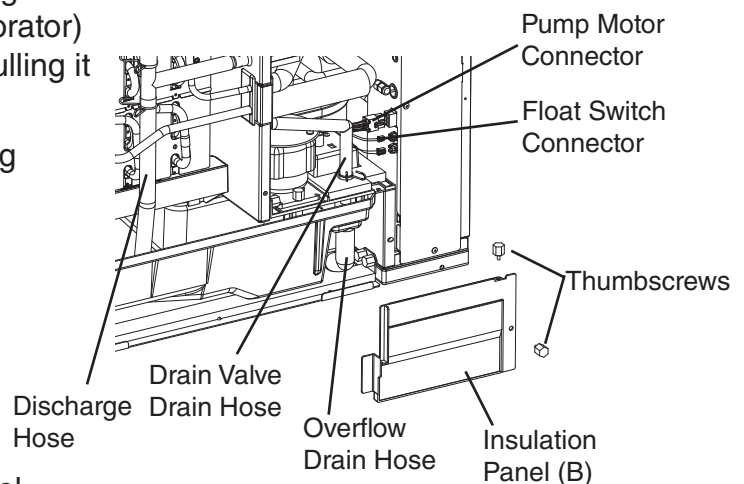

Fig. 6

- 7) Remove the 2 thumbscrews securing the pump motor and float switch assembly. See Fig. 7.
- 8) Pull out the water tank, cube guide, and pump motor and float switch assembly together.
- 9) Remove the screw securing the float switch to the top of the assembly. Remove the float switch from the assembly.
- 10) Remove the retainer rod from the bottom of the float switch, then remove the float. Be careful not to bend the retainer rod excessively when removing it. See Fig. 8.
- 11) Wipe down the float switch housing, shaft, float, and retainer rod with a mixture of 1 part Hoshizaki "Scale Away" and 25 parts warm water. Rinse the parts thoroughly with clean water.
- 12) Reassemble the float switch. Replace the float switch in its correct position, then secure with the screw.
- 13) Move the control switch to the "ICE" position, then replace the removed parts in the reverse order of which they were removed.

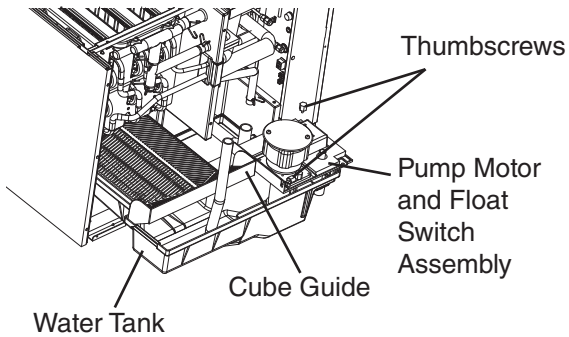

Fig. 7

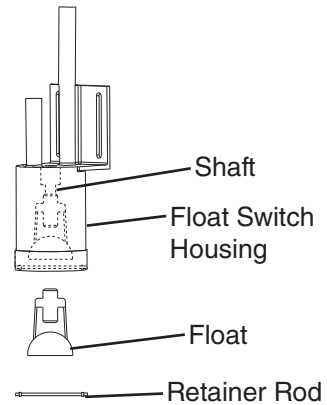
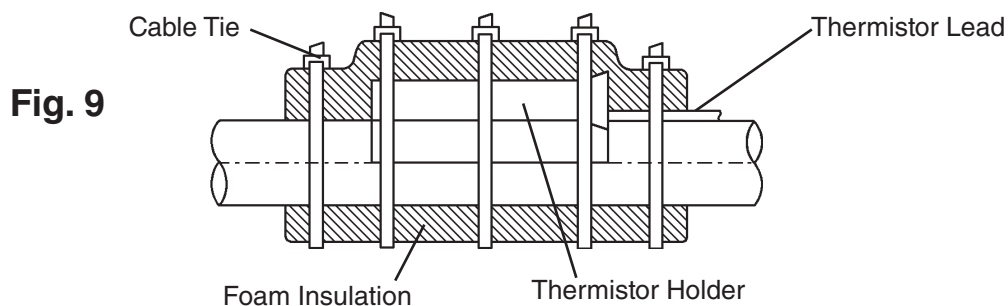

Fig. 8

E. Thermistor Check

To check thermistor resistance, follow the steps below.

- 1) Turn off the power supply.
- 2) Remove the front panel, then move the control switch to the "OFF" position.
- 3) Remove the control box cover.
- 4) Disconnect the wire connector from the control board K1 nine-pin connector. See "II. C.1. Control Board Layout." Make sure the thermistor connection on the side of the control box is secure.
- 5) Remove the plastic cable ties, foam insulation, thermistor holder, and thermistor. See Fig. 9.
- 6) Immerse the thermistor sensor portion in a glass containing ice and water for 2 or 3 minutes.
- 7) Check the resistance between the orange wires (6 & 7) of the wire connector. Normal reading is within 4.7 to 6.2 k Ω . If outside the normal reading, replace the thermistor. See "V.J. Removal and Replacement of Thermistor." If inside the normal reading, continue to the next step.
- 8) Scrape away the old sealant on the thermistor holder and the suction pipe.
- 9) Wipe off any moisture on the suction pipe.
- 10) Smoothly apply recommended sealant (KE4560RTV, Part Code 60Y000-11 or 4A0683-01) to the thermistor holder concave.
- 11) Attach the thermistor to the suction pipe in the same position as previous. Be very careful to prevent damage to the leads. Secure it using the thermistor holder and foam insulation.
- 12) Secure the insulation using plastic cable ties.
- 13) Reconnect the wire connector to the control board K1 nine-pin connector, then replace the control box cover in its correct position.
- 14) Move the control switch to the "ICE" position.
- 15) Replace the front panel in its correct position, then turn on the power supply.
- 16) Once the harvest cycle starts, begin timing the harvest cycle.
- 17) The harvest timer should expire and terminate the harvest cycle within 2 to 3 minutes. If the harvest timer does not expire and terminate the harvest cycle, the harvest timer is bad and the control board should be replaced. See "V.N. Removal and Replacement of Control Board."



F. Diagnostic Charts

1. No Ice Production

Problem	Possible Cause	Remedy	
[1] The icemaker will not start.	a) Power Supply	1. Off, blown fuse, or tripped breaker.	1. Turn on, replace, or reset.
		2. Loose connection.	2. Tighten.
		3. Bad contacts.	3. Check for continuity and replace.
		4. Not within specifications.	4. Refer to nameplate and correct.
	b) Water Supply	1. Water supply off or pressure too low.	1. Check and get recommended pressure.
	c) Bin Control	1. Tripped with bin filled with ice.	1. Remove ice.
		2. Defective.	2. See "IV.C. Bin Control Check."
	d) Fuse (Control Box)	1. Blown.	1. Check for short circuit and replace.
	e) Control Switch	1. "OFF" or "SERVICE" position.	1. Move to "ICE" position.
		2. Bad contacts.	2. Check for continuity and replace.
	f) High Pressure Control	1. Bad contacts.	1. Check for continuity and replace.
		2. Dirty air filter or condenser.	2. Clean.
		3. Ambient or condenser water temperature too warm.	3. Reduce temperature.
		4. Refrigerant overcharged.	4. Recover, evacuate, and recharge.
		5. Fan not operating (except water-cooled model).	5. See chart 1.[7].
		6. Refrigerant lines or components restricted.	6. Recover, repair, replace drier, evacuate, and recharge.
		7. Condenser water pressure too low or off (water-cooled model).	7. Check and get recommended pressure.
	g) Transformer	1. Coil winding open or shorted.	1. Replace.
	h) Wiring to Control Board	1. Loose connections or open.	1. Check for continuity and replace.
	i) Thermistor	1. Leads shorted or open and high temperature or harvest backup timer safety operates (1 beep or 2 beep alarm).	1. See "IV.E. Thermistor Check."

Problem	Possible Cause		Remedy
[1] The icemaker will not start. (continued)	j) Hot Gas Valve	1. Continues to open in freeze cycle and freeze timer safety operates (3 beep alarm).	1. Check for hot gas valve stuck open and replace.
	k) Inlet Water Valve	1. Mesh filter or orifice gets clogged and water supply cycle does not finish.	1. Clean.
		2. Coil winding open.	2. Replace.
		3. Wiring to inlet water valve.	3. Check for loose connection or open, and replace.
	l) Float Switch	1. Bad contacts.	1. Check for continuity and replace.
		2. Float does not move freely or switch defective.	2. Clean or replace. See "IV. D. Float Switch Check and Cleaning."
m) Control Board	1. Defective or in alarm.	1. See "IV.B. Control Board Check."	
[2] Fill cycle will not terminate.	a) Water Supply	1. Water supply off or pressure too low.	1. Check and get recommended pressure.
	b) Float Switch	1. Connector disconnected.	1. Reconnect.
		2. Float does not move freely or switch defective.	2. Clean or replace. See "IV. D. Float Switch Check and Cleaning."
	c) Control Board	1. Defective.	1. See "IV.B. Control Board Check."
[3] Compressor will not start or stops operating.	a) Magnetic Contactor	1. Bad contacts.	1. Check for continuity and replace.
		2. Coil winding open.	2. Replace.
	b) Start Capacitor or Run Capacitor	1. Defective.	1. Replace.
	c) Internal Overload Protector Open (check 1 through 3 to the right and d through f below)	1. Loose terminal.	1. Tighten or replace.
		2. Voltage.	2. Check and correct.
		3. Dirty condenser.	3. Clean.
	d) Starter	1. Bad contacts.	1. Check and replace.
		2. Coil winding open.	2. Replace.
	e) Compressor	1. Power supply not within specifications.	1. Refer to nameplate and correct.
		2. Wiring to compressor.	2. Check for loose connection or open, and replace.
		3. Defective.	3. Replace.
		4. Protector tripped.	4. Reduce temperature.
	f) Control Board	1. No power to contactor.	1. See "IV.B. Control Board Check."

Problem	Possible Cause		Remedy
[4] Water continues to be supplied in freeze cycle.	a) Water Pressure	1. Too high.	1. Reduce.
	b) Inlet Water Valve	1. Diaphragm does not close.	1. Check for water leaks with icemaker off.
	c) Control Board	1. Defective.	1. See "IV.B. Control Board Check."
[5] Pump motor will not start.	a) Pump Motor	1. Motor winding open.	1. Replace.
		2. Bearing worn out.	2. Replace.
		3. Wiring to pump motor.	3. Check for loose connection or open, and replace.
		4. Defective capacitor.	4. Replace.
		5. Defective or bound impeller.	5. Replace and clean.
	b) Control Board	1. Defective.	1. See "IV.B. Control Board Check."
c) Control Switch	1. Bad contacts.	1. Replace.	
[6] Freeze cycle time is too short.	a) Drain Valve	1. Leaking by.	1. Clean or replace.
	b) Float Switch	1. Dirty or erratic operation.	1. See "IV.D. Float Switch Check and Cleaning."
	c) Control Board	1. Defective.	1. See "IV.B. Control Board Check."
	d) Water System	1. Water leaks.	1. Check connections for water leaks and repair.
[7] Fan motor will not start, or is not operating (except water-cooled model).	a) Fan Motor	1. Motor winding open.	1. Replace.
		2. Bearing worn out.	2. Replace.
		3. Wiring to fan motor.	3. Check for loose connection or open, and replace.
		4. Defective capacitor.	4. Replace.
		5. Fan blade bound.	5. Check and replace.
	b) Control Board	1. Defective.	1. See "IV.B. Control Board Check."
[8] All components run, but no ice is produced.	a) Refrigerant	1. Low charge.	1. Check for leaks. Recover, repair, evacuate, and recharge.
		2. Air or moisture trapped.	2. Recover, replace drier, evacuate, and recharge.
	b) Compressor	1. Defective.	1. Replace.
	c) Hot Gas Valve	1. Continues to open in freeze cycle.	1. Check and replace.
	d) Liquid Line Valve (if applicable)	1. Continues to close in freeze cycle.	1. Check and replace.
	e) Inlet Water Valve	1. Inlet water valve is wide open during freeze.	1. Check for water leaks with icemaker off.
	f) Expansion Valve	1. Bulb loose.	1. Secure bulb.
		2. Operating erratically.	2. Check and replace.

Problem	Possible Cause	Remedy	
[8] All components run, but no ice is produced. (continued)	g) Headmaster (C.P.R.) (remote condenser unit)	1. Not operating properly and liquid line temperature too warm.	1. Replace headmaster.
	h) Water Supply Line (water-cooled model)	1. Condenser water pressure too low or off and high pressure control opens and closes frequently.	1. Check and get recommended pressure.
	i) Water Regulating Valve (water-cooled model)	1. Set too high.	1. Adjust or replace. See "V.I. Adjustment of Water Regulating Valve (water-cooled model)."

2. Evaporator is Frozen Up

Problem	Possible Cause	Remedy	
[1] Freeze cycle time is too long.	a) Inlet Water Valve	1. Diaphragm does not close.	1. Check for water leaks with icemaker off.
	b) Float Switch	1. Float does not move freely or switch defective.	1. Clean or replace. See "IV. D. Float Switch Check and Cleaning."
	c) Evaporator	1. Scaled up.	1. Clean.
		2. Damaged.	2. Replace.
	d) Spray Tubes	1. Dirty.	1. Clean.
		2. Out of position.	2. Place in position.
	e) Pump Motor	1. RPM too slow.	1. See chart 1.[5].
	f) Thermistor	1. Disconnected, loose, or defective.	1. Connect, secure, check. See "V.J. Removal and Replacement of Thermistor" and "IV.E. Thermistor Check."
	g) Refrigerant	1. Low charge.	1. Check for leaks. Recover, repair, evacuate, and recharge.
h) Expansion Valve	1. Bulb loose.	1. Secure bulb.	
	2. Operating erratically.	2. Check and replace.	
i) Control Board	1. Defective.	1. See "IV.B. Control Board Check."	
[2] All ice formed on evaporator does not fall into bin in harvest cycle.	a) Evaporator	1. Scaled up.	1. Clean.
		2. Damaged.	2. Replace.
	b) Ambient and/or Water Temperature	1. Too cool.	1. Increase temperature.
	c) Water Supply Line	1. Water pressure too low.	1. Check and get recommended pressure.
d) Water System	1. Water supply line too small; requires 3/8" OD line dedicated per machine.	1. Increase water line size.	
	2. Water filter clogged or flow rate too small.	2. Replace filter or install a higher flow rate filter.	

Problem	Possible Cause		Remedy
[2] All ice formed on evaporator does not fall into bin in harvest cycle. (continued)	e) Inlet Water Valve	1. Dirty mesh filter or orifice.	1. Clean.
		2. Diaphragm does not close.	2. Check for water leaks with icemaker off.
	f) Spray Tubes	1. Dirty.	1. Clean.
		2. Out of position.	2. Place in position.
	g) Thermistor	1. Disconnected, loose, or defective.	1. Connect, secure, check. See "V.J. Removal and Replacement of Thermistor" and "IV.E. Thermistor Check."
	h) Hot Gas Valve	1. Coil winding open.	1. Replace.
		2. Plunger does not move.	2. Replace.
		3. Wiring to hot gas valve.	3. Check for loose or open connection. Reconnect or replace.
	i) Expansion Valve	1. Open.	1. Check and replace.
		2. Bulb loose.	2. Secure bulb.
	j) Liquid Line Valve (if applicable)	1. Continues to open in harvest cycle.	1. Check operation in harvest cycle and replace.
	k) Control Board	1. Harvest timer is set too short.	1. Adjust longer, referring to "II.C.3.b) Harvest Timer (S1 dip switch 1 & 2)."
		2. Defective.	2. See "IV.B. Control Board Check."
l) Refrigerant	1. Low charge.	1. Check for leaks. Recover, repair, evacuate, and recharge.	
m) Water Regulating Valve (water-cooled model)	1. Leaking by in harvest.	1. Check and replace.	

Problem	Possible Cause	Remedy
[3] Other.	a) Ice Cube Guide	1. Out of position. 1. Place in position.
	b) Bin Control	1. Movement restricted. 1. Check and free.
		2. Defective. 2. See "IV.C. Bin Control Check and Cleaning."

3. Low Ice Production

Problem	Possible Cause	Remedy
[1] Freeze cycle time is long.	a) Inlet Water Valve	1. Diaphragm does not close. 1. Check for water leaks with icemaker off.
	b) Float Switch	1. Float does not move freely or switch defective. 1. Clean or replace. See "IV. D. Float Switch Check and Cleaning."
	c) Thermistor	1. Disconnected, loose, or defective. 1. Connect, secure, check. See "V.J. Removal and Replacement of Thermistor" and "IV.E. Thermistor Check."
	d) Evaporator	1. Scaled up. 1. Clean.
		2. Damaged. 2. Replace.
	e) Spray Tubes	1. Dirty. 1. Clean.
		2. Out of position. 2. Place in position.
	f) Pump Motor	1. RPM too slow. 1. See chart 1.[5].
	g) Condenser (except water-cooled model)	1. Air filter or condenser clogged. 1. Clean.
	h) Refrigerant Charge	1. Low charge. 1. Check for leaks. Recover, repair, evacuate, and recharge.
	i) Hot Gas Valve	1. Open. 1. Check and replace.
	j) Expansion Valve	1. Bulb loose. 1. Secure bulb.
		2. Operating erratically. 2. Check and replace.
	k) Compressor	1. Erratic or off. 1. See chart 1.[3].
	l) Condenser Water (water-cooled model)	1. Water regulating valve set too high. 1. Adjust or replace. See "V.I. Adjustment of Water Regulating Valve (water-cooled model)."
2. Condenser water pressure too low. 2. Check and get recommended pressure.		
3. Water temperature out of specification. 3. Correct to specification.		
m) Liquid Line Valve	1. Erratic, sticking. 1. Check and replace.	
n) Headmaster (C.P.R.) (remote condenser unit)	1. Bypassing. 1. Replace.	

Problem	Possible Cause		Remedy
[1] Freeze cycle time is long. (continued)	o) Control Board	1. Refill counter (S2 dip switch 3 & 4) not in the factory default position.	1. Set to factory default position. See "II.C.3.a) Default Dip Switch Settings."
		2. Float switch connection loose.	2. Check and reconnect.
		3. Defective.	3. See "IV.B. Control Board Check."
[2] Harvest cycle time is long.	a) Water Supply	1. Water temperature too cold.	1. Increase temperature.
	b) Thermistor	1. Disconnected, loose, or defective.	1. Connect, secure, check. See "V.J. Removal and Replacement of Thermistor" and "IV.E. Thermistor Check."
	c) Control Board	1. Not reading thermistor.	1. Check and replace.
		2. Sending voltage to liquid line valve (if applicable) in harvest.	2. Check and replace. See "IV.B. Control Board Check."
	d) Inlet Water Valve	1. Clogged.	1. Clean or replace.
	e) Evaporator	1. Scaled up.	1. Clean.
		2. Damaged.	2. Replace.
	f) Hot Gas Valve	1. Does not open, or opens partially.	1. Check and replace.
	g) Expansion Valve	1. Wide open in harvest.	1. Check and replace.
		2. Bulb loose.	2. Secure bulb.
h) Water Regulating Valve (water-cooled model)	1. Open during harvest.	1. Adjust or replace. See "V.I. Adjustment of Water Regulating Valve (water-cooled model)."	
i) Liquid Line Valve	1. Open during harvest cycle.	1. Check and replace.	

4. Abnormal Ice

Problem	Possible Cause		Remedy
[1] Small cubes.	a) Drain Valve	1. Dirty and leaking by.	1. Clean or replace.
	b) Ice Cube Guide	1. Out of position. Circulated water falls into bin.	1. Place in position.
	c) Water System	1. Water supply line too small; requires 3/8" OD line dedicated per machine.	1. Increase water line size.
		2. Water filter clogged or flow rate too small.	2. Replace filter or install a higher flow rate filter.
	d) Inlet Water Valve	1. Dirty mesh filter or orifice.	1. Clean.
	e) Pump Motor	1. RPM too slow.	1. See chart 1.[5].

Problem	Possible Cause		Remedy
[1] Small cubes. (continued)	f) Control Board	1. Defective.	1. See "IV.B. Control Board Check."
[2] Cloudy or irregular cubes.	a) Evaporator	1. Frozen up.	1. See chart 2.
		2. Scaled up.	2. Clean
		3. Damaged.	3. Replace.
	b) Water System	1. Water supply line too small; requires 3/8" OD line dedicated per machine.	1. Increase water line size.
		2. Water filter clogged or flow rate too small.	2. Replace filter or install a higher flow rate filter.
		3. High hardness or contains impurities.	3. Install a water softener or filter.
c) Spray Guide	1. Dirty.	1. Clean.	

5. Other

Problem	Possible Cause		Remedy
[1] Icemaker will not stop when bin is filled with ice.	a) Bin Control	1. Movement restricted.	1. Check and free.
		2. Loose connection.	2. Check and reconnect.
		3. Defective.	3. See "IV.C. Bin Control Check and Cleaning."
[2] Abnormal noise.	a) Pump Motor	1. Bearings worn out.	1. Replace.
	b) Fan Motor (except water-cooled model)	1. Bearings worn out.	1. Replace.
		2. Fan blade deformed.	2. Replace.
		3. Fan blade does not move freely.	3. Replace.
	c) Compressor	1. Bearings worn out or cylinder valve broken.	1. Replace.
		2. Mounting pad out of position.	2. Reinstall.
d) Refrigerant Lines	1. Rub or touch other lines or surfaces.	1. Reposition.	
[3] Ice in dispenser unit/storage bin often melts.	a) Drain Line(s)	1. Plugged.	1. Clean.
	b) Icemaker and Dispenser Unit/Storage Bin	1. Drains not run separately.	1. Separate the drain lines.
	c) Ice Cube Guide	1. Out of position. Circulated water falls into bin.	1. Place in position.
[4] Pump motor de-energizes for 10 seconds during freeze cycle.	a) Control Board	1. Anti-slush control (S2 dip switch 6) activated.	1. Default setting on certain models. Set to factory default position. See "II. C.3.a) Default Dip Switch Settings."

V. Removal and Replacement of Components

⚠ WARNING

1. This unit should be diagnosed and repaired only by qualified service personnel to reduce the risk of death, electric shock, serious injury, or fire.
2. Move the control switch to the "OFF" position and turn off the power supply before servicing.
3. **CHOKING HAZARD:** Ensure all components, fasteners, and thumbscrews are securely in place after the unit is serviced. Make sure that none have fallen into the dispenser unit/storage bin.
4. Make sure all food zones in the icemaker and dispenser unit/storage bin are clean after the unit is serviced. For cleaning procedures, see "VI. Cleaning and Maintenance."

A. Service for Refrigerant Lines

⚠ WARNING

1. Repairs requiring the refrigeration circuit to be opened must be performed by properly trained and EPA-certified service personnel.
2. Always recover the refrigerant and store it in an approved container. Do not discharge the refrigerant into the atmosphere.
3. Use an electronic leak detector or soap bubbles to check for leaks. Add a trace of refrigerant to the system (if using an electronic leak detector), and then raise the pressure using nitrogen gas (140 PSIG). DO NOT use R-404A as a mixture with pressurized air for leak testing.

CAUTION

1. Do not leave the system open for longer than 15 minutes when replacing or servicing parts. The Polyol Ester (POE) oils used in R-404A units can absorb moisture quickly. Therefore it is important to prevent moisture from entering the system when replacing or servicing parts.
2. Always install a new drier every time the sealed refrigeration system is opened.
3. Do not replace the drier until after all other repair or replacement has been made. Install the new drier with the arrow on the drier in the direction of the refrigerant flow.
4. When brazing, protect the drier by using a wet cloth to prevent the drier from overheating. Do not allow the drier to exceed 250°F (121°C).

1. Refrigerant Recovery

The icemaker unit is provided with refrigerant access valves. Using proper refrigerant practices, recover the refrigerant from the access valves and store it in an approved container. Do not discharge the refrigerant into the atmosphere.

2. Brazing

⚠ WARNING

1. R-404A itself is not flammable at atmospheric pressure and temperatures up to 176°F (80°C).
2. R-404A itself is not explosive or poisonous. However, when exposed to high temperatures (open flames), R-404A can be decomposed to form hydrofluoric acid and carbonyl fluoride both of which are hazardous.
3. Do not use silver alloy or copper alloy containing arsenic.
4. Use an electronic leak detector or soap bubbles to check for leaks. Add a trace of refrigerant to the system (if using an electronic leak detector), and then raise the pressure using nitrogen gas (140 PSIG). DO NOT use R-404A as a mixture with pressurized air for leak testing.

- 1) Braze all fittings while purging with nitrogen gas flowing at a pressure of 3 to 4 PSIG.

Note: Because the pipes in the evaporator case are specially coated to resist corrosion, it is important to make connections outside the evaporator case when possible. If it is necessary to braze inside the evaporator case, use sandpaper to remove the coating from the brazing connections before unbrazing the components.

CAUTION

1. Always install a new drier every time the sealed refrigeration system is opened.
2. Do not replace the drier until after all other repair or replacement has been made. Install the new drier with the arrow on the drier in the direction of the refrigerant flow.
3. When brazing, protect the drier by using a wet cloth to prevent the drier from overheating. Do not allow the drier to exceed 250°F (121°C).

- 2) Use an electronic leak detector or soap bubbles to check for leaks. Add a trace of refrigerant to the system (if using an electronic leak detector), and then raise the pressure using nitrogen gas (140 PSIG). DO NOT use R-404A as a mixture with pressurized air for leak testing.

3. Evacuation and Recharge (R-404A)

- 1) Attach a vacuum pump to the system. Be sure to connect the charging hoses to both high and low-side access valves.

IMPORTANT

The vacuum level and vacuum pump may be the same as those for current refrigerants. However, the rubber hose and gauge manifold to be used for evacuation and refrigerant charge should be exclusively for POE oils.

- 2) Turn on the vacuum pump. Open the gauge manifold valves. Never allow the oil in the vacuum pump to flow backwards.
- 3) Allow the vacuum pump to pull down to a 29.9" Hg vacuum. Evacuating period depends on pump capacity.

- 4) Close the low-side valve and high-side valve on the gauge manifold.
- 5) Disconnect the gauge manifold hose from the vacuum pump and attach it to a refrigerant service cylinder. Remember to loosen the connection and purge the air from the hose. For air-cooled and water-cooled models, see the nameplate for the required refrigerant charge. For remote air-cooled model, see the rating label inside the icemaker. Hoshizaki recommends only virgin refrigerant or reclaimed refrigerant which meets ARI Standard 700 (latest edition) be used.
- 6) A liquid charge is recommended for charging an R-404A system. Invert the service cylinder and place it on scales. Open the high-side valve on the gauge manifold.
- 7) Allow the system to charge with liquid until the proper charge weight is met.
- 8) If necessary, add any remaining charge to the system through the low-side. Use a throttling valve or liquid dispensing device to add the remaining liquid charge through the low-side access valve with the unit running.
- 9) Close the gauge manifold valves and disconnect the gauge manifold hoses.
- 10) Cap the access valves to prevent a possible leak.

B. Removal and Replacement of Compressor

CAUTION

1. Always install a new drier every time the sealed refrigeration system is opened.
2. Do not replace the drier until after all other repair or replacement has been made. Install the new drier with the arrow on the drier in the direction of the refrigerant flow.
3. When brazing, protect the drier by using a wet cloth to prevent the drier from overheating. Do not allow the drier to exceed 250°F (121°C).

Note: When replacing a compressor with a defective winding, be sure to install the new start capacitor and start relay supplied with the replacement compressor. Due to the ability of the POE oil in the compressor to absorb moisture quickly, the compressor must not be opened more than 15 minutes for replacement or service. Do not mix lubricants of different compressors even if both are charged with R-404A, except when they use the same lubricant.

- 1) Turn off the power supply.
- 2) Remove the panels.
- 3) Recover the refrigerant and store it in an approved container.
- 4) Remove the terminal cover on the compressor and disconnect the compressor wiring. On remote air-cooled model, disconnect the crankcase heater.
- 5) Remove the drier and the discharge, suction, and process pipes.
- 6) Remove the hold-down bolts, washers, and rubber grommets.
- 7) Remove the compressor. Unpack the new compressor package.
- 8) Attach the rubber grommets of the prior compressor to the new compressor.

- 9) Place the compressor in position and secure it using the bolts and washers.
- 10) Place the new drier in position.
- 11) Remove the plugs from the suction, discharge, and process pipes.
- 12) Braze all fittings while purging with nitrogen gas flowing at a pressure of 3 to 4 PSIG.
- 13) Use an electronic leak detector or soap bubbles to check for leaks. Add a trace of refrigerant to the system (if using an electronic leak detector), and then raise the pressure using nitrogen gas (140 PSIG). DO NOT use R-404A as a mixture with pressurized air for leak testing.
- 14) Evacuate the system and charge it with refrigerant. For air-cooled and water-cooled models, see the nameplate for the required refrigerant charge. For remote air-cooled model, see the rating label inside the icemaker.
- 15) Connect the terminals and replace the terminal cover in its correct position. On remote air-cooled model, connect the crankcase heater.
- 16) Replace the panels in their correct positions.
- 17) Turn on the power supply.

C. Removal and Replacement of Expansion Valve

Moisture in the refrigeration circuit may exceed drier capacity and freeze up at the expansion valve.

CAUTION

1. Always install a new drier every time the sealed refrigeration system is opened.
2. Do not replace the drier until after all other repair or replacement has been made. Install the new drier with the arrow on the drier in the direction of the refrigerant flow.
3. When brazing, protect the valve body and drier by using wet cloths to prevent the valve body and drier from overheating. Do not allow the valve body or drier to exceed 250°F (121°C).

- 1) Turn off the power supply.
- 2) Remove the panels.
- 3) Recover the refrigerant and store it in an approved container.
- 4) Remove the insulation and the expansion valve bulb on the suction line.
- 5) Remove the expansion valve cover and disconnect the expansion valve. Place the new expansion valve in position.
- 6) Remove the drier, then place the new drier in position.
- 7) Braze all fittings while purging with nitrogen gas flowing at a pressure of 3 to 4 PSIG.
- 8) Use an electronic leak detector or soap bubbles to check for leaks. Add a trace of refrigerant to the system (if using an electronic leak detector), and then raise the pressure using nitrogen gas (140 PSIG). DO NOT use R-404A as a mixture with pressurized air for leak testing.

- 9) Evacuate the system, and charge it with refrigerant. For air-cooled and water-cooled models, see the nameplate for the required refrigerant charge. For remote air-cooled model, see the rating label inside the icemaker.
- 10) Attach the expansion valve bulb to the suction line in the same location as the previous bulb. The bulb should be between the 10 and 2 o'clock position on the tube. Be sure to secure the bulb with the clamp and holder and to insulate it.
- 11) Place the expansion valve cover in position.
- 12) Replace the panels in their correct positions.
- 13) Turn on the power supply.

D. Removal and Replacement of Hot Gas Valve or Liquid Line Valve

CAUTION

1. Always use a copper tube of the same diameter and length when replacing the valve lines; otherwise, performance may be affected.
2. Always replace the strainer when replacing the hot gas valve.
3. Always install a new drier every time the sealed refrigeration system is opened.
4. Do not replace the drier until after all other repair or replacement has been made. Install the new drier with the arrow on the drier in the direction of the refrigerant flow.
5. When brazing, protect the valve body and drier by using wet cloths to prevent the valve body and drier from overheating. Do not allow the valve body or drier to exceed 250°F (121°C).

- 1) Turn off the power supply.
- 2) Remove the panels.
- 3) Recover the refrigerant and store it in an approved container.
- 4) Remove the solenoid.
- 5) Disconnect the valve. If replacing the hot gas valve, also remove the strainer.
- 6) Place the new valve and strainer (if applicable) in position.
- 7) Remove the drier, then place the new drier in position.
- 8) Braze all fittings while purging with nitrogen gas flowing at a pressure of 3 to 4 PSIG.
- 9) Use an electronic leak detector or soap bubbles to check for leaks. Add a trace of refrigerant to the system (if using an electronic leak detector), and then raise the pressure using nitrogen gas (140 PSIG). DO NOT use R-404A as a mixture with pressurized air for leak testing.
- 10) Evacuate the system, and charge it with refrigerant. For air-cooled and water-cooled models, see the nameplate for the required refrigerant charge. For remote air-cooled model, see the rating label inside the icemaker.
- 11) Replace the solenoid in its correct position.

- 12) Replace the panels in their correct positions.
- 13) Turn on the power supply.

E. Removal and Replacement of Evaporator

CAUTION

1. Always install a new drier every time the sealed refrigeration system is opened.
2. Do not replace the drier until after all other repair or replacement has been made. Install the new drier with the arrow on the drier in the direction of the refrigerant flow.
3. When brazing, protect the drier by using a wet cloth to prevent the drier from overheating. Do not allow the drier to exceed 250°F (121°C).

- 1) Turn off the power supply.
- 2) Remove the panels and the front and top insulation.
- 3) Recover the refrigerant and store it in an approved container.
- 4) Remove the spray tubes, spray guides, and water guides. Remove the insulation at the notch where the refrigeration tubing passes through the molded chassis.
- 5) Disconnect the evaporator tubing.
Note: The pipes in the evaporator case are specially coated to resist corrosion. Use sandpaper to remove the coating from the brazing connections before unbrazing.
- 6) Remove the screws securing the evaporator brackets, then lift out the evaporator.
- 7) Remove the pop rivets securing the evaporator brackets. Attach the evaporator brackets to the new evaporator.
- 8) Install the new evaporator.
- 9) Remove the drier, then place the new drier in position.
- 10) Braze all fittings while purging with nitrogen gas flowing at a pressure of 3 to 4 PSIG.
- 11) Use an electronic leak detector or soap bubbles to check for leaks. Add a trace of refrigerant to the system (if using an electronic leak detector), and then raise the pressure using nitrogen gas (140 PSIG). DO NOT use R-404A as a mixture with pressurized air for leak testing.
- 12) Evacuate the system, and charge it with refrigerant. For air-cooled and water-cooled models, see the nameplate for the required refrigerant charge. For remote air-cooled model, see the rating label inside the icemaker.
- 13) Replace the removed parts in the reverse order of which they were removed.
- 14) Replace the insulation and the panels in their correct positions.
- 15) Turn on the power supply.

F. Removal and Replacement of Air-Cooled Condenser

CAUTION

1. Always install a new drier every time the sealed refrigeration system is opened.
2. Do not replace the drier until after all other repair or replacement has been made. Install the new drier with the arrow on the drier in the direction of the refrigerant flow.
3. When brazing, protect the drier by using a wet cloth to prevent the drier from overheating. Do not allow the drier to exceed 250°F (121°C).

- 1) Turn off the power supply.
- 2) Remove the panels.
- 3) Recover the refrigerant and store it in an approved container.
- 4) Disconnect the condenser inlet and outlet piping.
- 5) Remove the corner barrier from the condenser.
- 6) Remove the screws securing the condenser assembly, then remove the assembly.
- 7) Install the new condenser, then attach the corner barrier.
- 8) Remove the drier, then place the new drier in position.
- 9) Braze all fittings while purging with nitrogen gas flowing at a pressure of 3 to 4 PSIG.
- 10) Use an electronic leak detector or soap bubbles to check for leaks. Add a trace of refrigerant to the system (if using an electronic leak detector), and then raise the pressure using nitrogen gas (140 PSIG). DO NOT use R-404A as a mixture with pressurized air for leak testing.
- 11) Evacuate the system, and charge it with refrigerant. See the nameplate for the required refrigerant charge.
- 12) Replace the panels in their correct positions.
- 13) Turn on the power supply.

G. Removal and Replacement of Water-Cooled Condenser

CAUTION

1. Always install a new drier every time the sealed refrigeration system is opened.
2. Do not replace the drier until after all other repair or replacement has been made. Install the new drier with the arrow on the drier in the direction of the refrigerant flow.
3. When brazing, protect the drier by using a wet cloth to prevent the drier from overheating. Do not allow the drier to exceed 250°F (121°C).

- 1) Turn off the power supply.
- 2) Remove the panels.

- 3) Close the condenser water supply line shut-off valve. If connected to a closed loop water supply, also close the condenser return outlet shut-off valve.
- 4) Open the condenser water supply line drain valve. If connected to a closed loop water supply, also open the condenser return outlet drain valve.
- 5) Attach a compressed air or carbon dioxide supply to the condenser water supply line drain valve.
- 6) Open the water regulating valve by using a screwdriver to pry up on the spring retainer underneath the spring. While holding the valve open, blow out the condenser using the compressed air or carbon dioxide supply until water stops coming out.
- 7) Recover the refrigerant and store it in an approved container.
- 8) Disconnect the condenser water inlet and outlet piping and the refrigeration inlet and outlet piping at the condenser.
- 9) Remove the old condenser and install the new condenser.
- 10) Remove the drier, then place the new drier in position.
- 11) Braze all fittings while purging with nitrogen gas flowing at a pressure of 3 to 4 PSIG.
- 12) Use an electronic leak detector or soap bubbles to check for leaks. Add a trace of refrigerant to the system (if using an electronic leak detector), and then raise the pressure using nitrogen gas (140 PSIG). DO NOT use R-404A as a mixture with pressurized air for leak testing.
- 13) Evacuate the system, and charge it with refrigerant. See the nameplate for the required refrigerant charge.
- 14) Close the drain valve(s). Open the condenser water supply line shut-off valve. If connected to a closed loop water supply, also open the condenser return outlet shut-off valve.
- 15) Check for water leaks.
- 16) Replace the panels in their correct positions.
- 17) Turn on the power supply.

H. Removal and Replacement of Water Regulating Valve (water-cooled model)

CAUTION

1. Always install a new drier every time the sealed refrigeration system is opened.
2. Do not replace the drier until after all other repair or replacement has been made. Install the new drier with the arrow on the drier in the direction of the refrigerant flow.
3. When brazing, protect the drier by using a wet cloth to prevent the drier from overheating. Do not allow the drier to exceed 250°F (121°C).

- 1) Turn off the power supply.
- 2) Remove the panels.
- 3) Close the condenser water supply line shut-off valve. If connected to a closed loop water supply, also close the condenser return outlet shut-off valve.
- 4) Open the condenser water supply line drain valve. If connected to a closed loop water supply, also open the condenser return outlet drain valve.
- 5) Attach a compressed air or carbon dioxide supply to the condenser water supply line drain valve.
- 6) Open the water regulating valve by using a screwdriver to pry up on the spring retainer underneath the spring. While holding the valve open, blow out the condenser using the compressed air or carbon dioxide supply until water stops coming out.
- 7) Recover the refrigerant and store it in an approved container.
- 8) Disconnect the capillary tube at the condenser outlet.
- 9) Disconnect the flare-connections of the valve.
- 10) Remove the screws and the valve from the bracket.
- 11) Install the new valve.
- 12) Remove the drier, then place the new drier in position.
- 13) Braze all fittings while purging with nitrogen gas flowing at a pressure of 3 to 4 PSIG.
- 14) Use an electronic leak detector or soap bubbles to check for leaks. Add a trace of refrigerant to the system (if using an electronic leak detector), and then raise the pressure using nitrogen gas (140 PSIG). DO NOT use R-404A as a mixture with pressurized air for leak testing.
- 15) Evacuate the system, and charge it with refrigerant. See the nameplate for the required refrigerant charge.
- 16) Connect the flare-connections.
- 17) Close the drain valve(s). Open the condenser water supply line shut-off valve. If connected to a closed loop water supply, also open the condenser return outlet shut-off valve.
- 18) Check for water leaks.

- 19) Replace the panels in their correct positions.
- 20) Turn on the power supply.

I. Adjustment of Water Regulating Valve (water-cooled model)

The water regulating valve (also called "water regulator") is factory-adjusted. No adjustment is required under normal use. Adjust the water regulator, if necessary, using the following procedures.

- 1) Prepare a thermometer to check the condenser drain temperature. Attach a pressure gauge to the high-side line of the system.
- 2) Five minutes after a freeze cycle starts, confirm that the thermometer reads 104°F to 115°F (40°C to 46°C). If it does not, rotate the adjustment screw by using a flat blade screwdriver until the temperature is in the proper range. See Fig. 10. Next, check that the reference pressure is in the range indicated in the Head Pressure table. See "III.C. Performance Data." If it is not in the proper range, verify the refrigerant charge.
- 3) Check that the condenser drain temperature is stable.

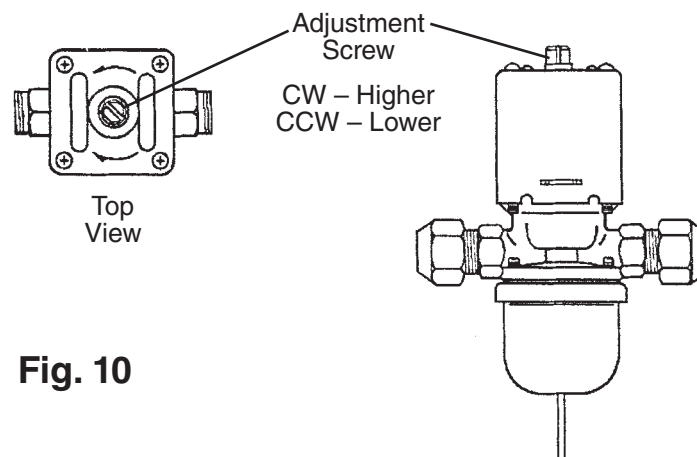

Fig. 10

J. Removal and Replacement of Thermistor

This section covers removal and replacement of the thermistor. For a thermistor check procedure, see "IV.E. Thermistor Check."

CAUTION

1. The thermistor is fragile; handle very carefully.
2. Always use the recommended sealant (high thermal conductive type), Model KE4560RTV manufactured by SHINETSU SILICONE, Part Code 60Y000-11, or Part Code [4A0683-01](#) or equivalent.
3. Always use the recommended foam insulation (non-absorbent type) or equivalent.
4. Do not shorten or cut the thermistor leads.

- 1) Turn off the power supply.
- 2) Remove the panels.
- 3) Remove the control box cover.
- 4) Disconnect the thermistor (orange wires) at the 2-pin connector on the control box. See Fig. 11.
- 5) Remove the plastic cable ties, foam insulation, thermistor holder, and thermistor. See Fig. 12.
- 6) Scrape away the old sealant on the thermistor holder and the suction pipe.
- 7) Wipe off any moisture on the suction pipe.
- 8) Smoothly apply recommended sealant (KE4560RTV, Part Code 60Y000-11 or [4A0683-01](#)) to the thermistor holder concave.
- 9) Attach the new thermistor to the suction pipe in the same position as the previous thermistor. Be very careful to prevent damage to the leads. Secure it using the thermistor holder and recommended foam insulation.
- 10) Secure the insulation using the plastic cable ties.
- 11) Connect the thermistor (orange wires) at the 2-pin connector on the control box.
Note: Do not shorten or cut the thermistor leads.
- 12) Replace the control box cover and the panels in their correct positions.
- 13) Turn on the power supply.

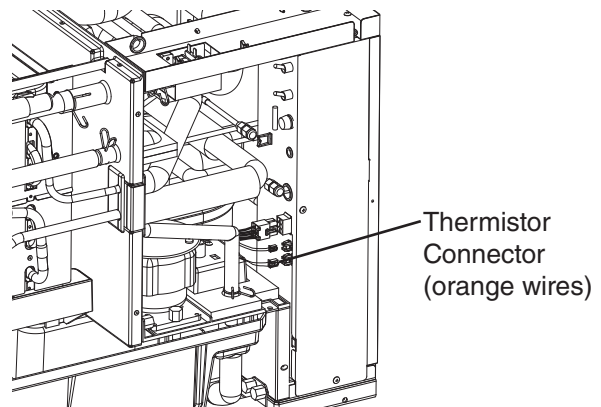

Fig. 11

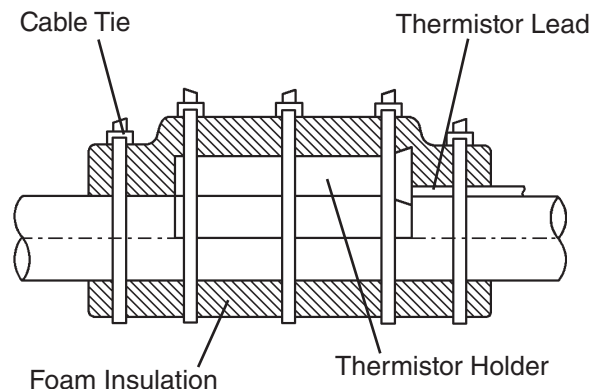

Fig. 12

K. Removal and Replacement of Fan Motor (air-cooled and remote air-cooled models)

Note: When replacing a fan motor with defective winding, it is recommended that a new capacitor be installed.

- 1) Turn off the power supply.
- 2) Remove the panels.
- 3) Remove the junction box cover from the remote condenser unit (remote air-cooled model).
- 4) Disconnect the fan motor wires and the capacitor wires.
- 5) Remove the fan motor bracket, fan motor, and capacitor.
- 6) Install the new fan motor and capacitor onto the fan motor bracket. Install the assembly into the icemaker and connect the fan motor and capacitor wires. Make sure the wires are properly routed in the wire saddles and do not interfere with the fan blade.
- 7) Replace the panels in their correct positions.
- 8) Replace the junction box cover in its correct position (remote air-cooled model).
- 9) Turn on the power supply.

L. Removal and Replacement of Water Valves

- 1) Turn off the power supply.
- 2) If replacing the inlet water valve, close the icemaker water supply line shut-off valve. Open the icemaker water supply line drain valve.
- 3) Remove the panels.
- 4) Disconnect the tubing attached to the valve. If replacing the inlet water valve, loosen the fitting nut. Be careful not to lose the washer.
- 5) Disconnect the terminals from the valve.
- 6) Remove the bracket (if applicable) and valve from the unit.
- 7) Install the new valve. Replace the removed parts in the reverse order of which they were removed. If replacing the inlet water valve, make sure the washer is in place in the fitting nut.
- 8) If replacing the inlet water valve, close the icemaker water supply line drain valve. Open the icemaker water supply line shut-off valve.
- 9) Turn on the power supply.
- 10) Check for leaks.
- 11) Replace the panels in their correct positions.

M. Removal and Replacement of Pump Motor

- 1) Turn off the power supply.
- 2) Remove the front panel
- 3) Disconnect the discharge hose and the drain valve drain hose. See Fig. 13.
- 4) Disconnect the pump motor connector from the side of the control box.
- 5) Remove the thumbscrew securing the pump motor to the top of the assembly. Remove the pump motor from the assembly.
- 6) Wire and install the new pump motor and replace the removed parts in the reverse order of which they were removed. Be sure to connect the ground wire.
- 7) Turn on the power supply.
- 8) Check for leaks.
- 9) Replace the front panel in its correct position.

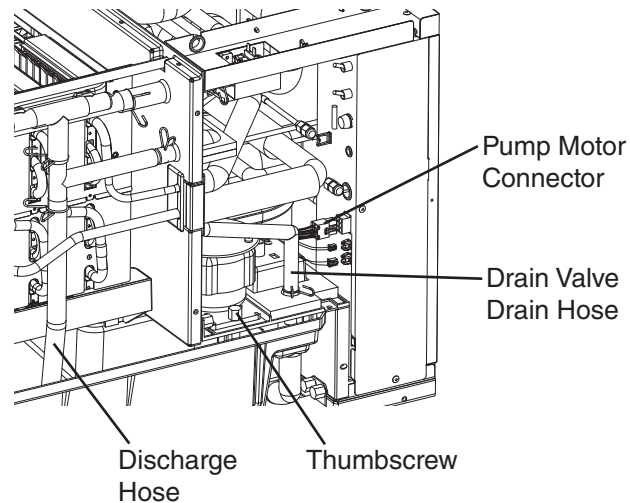

Fig. 13

N. Removal and Replacement of Control Board

- 1) Turn off the power supply.
- 2) Remove the front panel and the control box cover.
- 3) Disconnect the control board connectors from the control board.
- 4) Remove the control board.
- 5) Adjust the dip switches on the new control board to the factory default settings. See "II. C.3.a) Default Dip Switch Settings." S2 dip switch 5 must remain off.
- 6) Install the new control board taking care not to damage it.
- 7) Connect the control board connectors to the new control board.
- 8) Replace the control box cover and front panel in their correct positions.
- 9) Turn on the power supply.

VI. Cleaning and Maintenance

WARNING

CHOKING HAZARD: Ensure all components, fasteners, and thumbscrews are securely in place after any cleaning or maintenance is done to the unit. Make sure that none have fallen into the dispenser unit/storage bin.

A. Cleaning and Sanitizing Instructions

Hoshizaki recommends cleaning and sanitizing this unit at least once a year. More frequent cleaning and sanitizing, however, may be required in some existing water conditions.

WARNING

1. To prevent injury to individuals and damage to the icemaker, do not use ammonia type cleaners.
2. Carefully follow any instructions provided with the bottles of cleaning and sanitizing solution.
3. Always wear liquid-proof gloves and goggles to prevent the cleaning and sanitizing solutions from coming into contact with skin or eyes.
4. To prevent damage to the water pump, do not leave the control switch in the "SERVICE" position for extended periods of time when the water tank is empty.

1. Cleaning Procedure

- 1) Dilute 9.5 fl. oz. (281 ml) of Hoshizaki "Scale Away" with 1.8 gal. (6.8 l) of warm water.
- 2) Remove all ice from the evaporator and the dispenser unit/storage bin.
Note: To remove cubes on the evaporator, turn off the power supply and turn it on after 3 minutes. The harvest cycle starts and the cubes will be removed from the evaporator.
- 3) Turn off the power supply.
- 4) Remove the front panel, then move the service switch to the "DRAIN" position. Move the control switch to the "SERVICE" position.
- 5) Replace the front panel in its correct position, then turn on the power supply for 2 minutes.
- 6) Turn off the power supply.
- 7) Remove the front panel, then remove insulation panel (A) (the large insulation panel in front of the evaporator) by lifting up the panel slightly and pulling it towards you.

- 8) In bad or severe water conditions, clean the float switch as described below. Otherwise, continue to step 9.
 - a. Remove the 2 thumbscrews securing insulation panel (B), then remove insulation panel (B). See Fig. 14.
 - b. Disconnect the discharge hose, the drain valve drain hose, and the overflow drain hose.
 - c. Disconnect the pump motor connector and the float switch connector from the side of the control box.
 - d. Remove the 2 thumbscrews securing the pump motor and float switch assembly. See Fig. 15.
 - e. Pull out the water tank, cube guide, and pump motor and float switch assembly together.
 - f. Remove the screw securing the float switch to the top of the assembly. Remove the float switch from the assembly.
 - g. Remove the retainer rod from the bottom of the float switch, then remove the float. Be careful not to bend the retainer rod excessively when removing it.
 - h. Wipe down the float switch housing, shaft, float, and retainer rod with cleaning solution. Rinse the parts thoroughly with clean water.
 - i. Reassemble the float switch. Replace the float switch in its correct position, then secure with the screw.
 - j. Replace the removed parts in the reverse order of which they were removed.
- 9) Pour the cleaning solution into the water tank.
- 10) Move the service switch to the "WASH" position.
- 11) Replace insulation panel (A) and the front panel in their correct positions.
- 12) Turn on the power supply to start the washing process.
- 13) Turn off the power supply after 30 minutes.
- 14) Remove the front panel.
- 15) Move the service switch to the "DRAIN" position.
- 16) Replace the front panel in its correct position, then turn on the power supply for 2 minutes.

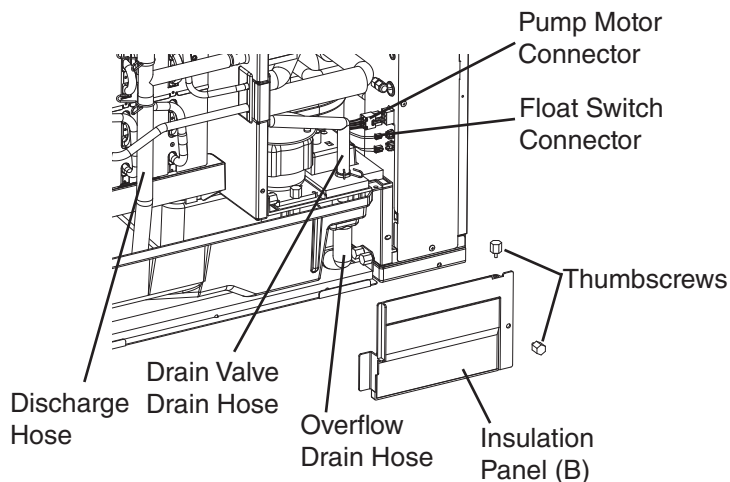

Fig. 14

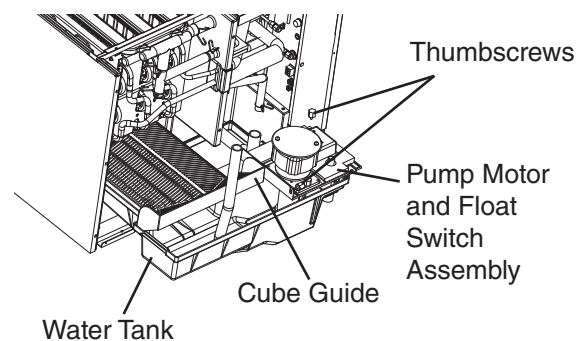

Fig. 15

- 17) Turn off the power supply, then remove the front panel.
- 18) Move the control switch to the "ICE" position.
- 19) Replace the front panel in its correct position.
- 20) Turn on the power supply to fill the water tank with water.
- 21) Turn off the power supply after 3 minutes.
- 22) Remove the front panel.
- 23) Move the service switch to the "WASH" position, then move the control switch to the "SERVICE" position.
- 24) Replace the front panel in its correct position.
- 25) Turn on the power supply to rinse off the cleaning solution.
- 26) Turn off the power supply after 5 minutes.
- 27) Remove the front panel.
- 28) Move the service switch to the "DRAIN" position.
- 29) Replace the front panel in its correct position, then turn on the power supply for 2 minutes.
- 30) Turn off the power supply.
- 31) Remove the front panel.
- 32) Repeat steps 18 through 31 three more times to rinse thoroughly.
Note: If you do not sanitize the icemaker, go to step 14 in "2. Sanitizing Procedure."

2. Sanitizing Procedure - Following Cleaning Procedure

- 1) Dilute 0.9 fl. oz. (27 ml) of a 5.25% sodium hypochlorite solution (chlorine bleach) with 1.8 gal. (6.8 l) of warm water.
- 2) Remove insulation panel (A).
- 3) Pour the sanitizing solution into the water tank.
- 4) Move the service switch to the "WASH" position.
- 5) Replace insulation panel (A) and the front panel in their correct positions.
- 6) Turn on the power supply to start the sanitizing process.
- 7) Turn off the power supply after 15 minutes.
- 8) Remove the front panel.
- 9) Move the service switch to the "DRAIN" position.
- 10) Replace the front panel in its correct position, then turn on the power supply for 2 minutes.
- 11) Turn off the power supply.
- 12) Remove the front panel.
- 13) Repeat steps 18 through 31 in "1. Cleaning Procedure" two times to rinse thoroughly.
- 14) Move the control switch to the "ICE" position.

- 15) Replace the front panel in its correct position.
- 16) Clean the dispenser unit/storage bin liner using a neutral cleaner. Rinse thoroughly after cleaning.
- 17) Turn on the power supply to start the automatic icemaking process.

B. Maintenance

This icemaker must be maintained individually, referring to the instruction manual and labels provided with the icemaker.

⚠ WARNING

1. Only qualified service technicians should attempt to service or maintain this icemaker.
2. Disconnect power before performing service or maintenance.

1. Stainless Steel Exterior

To prevent corrosion, wipe the exterior occasionally with a clean, soft cloth. Use a damp cloth containing a neutral cleaner to wipe off oil or dirt buildup.

2. Dispenser Unit/Storage Bin and Scoop

- Wash your hands before removing ice. Use the plastic scoop provided (bin accessory).
- The dispenser unit/storage bin is for ice use only. Do not store anything else in the dispenser unit/storage bin.
- Clean the scoop and the dispenser unit/storage bin liner using a neutral cleaner. Rinse thoroughly after cleaning.

3. Air Filters (air-cooled model)

Plastic mesh air filters remove dirt and dust from the air, and keep the condenser from getting clogged. As the filters get clogged, the icemaker's performance will be reduced. Check the filters at least twice a month. When clogged, use warm water and a neutral cleaner to wash the filters.

4. Condenser (air-cooled model)

Check the condenser once a year, and clean the coil if required by using a brush or vacuum cleaner. More frequent cleaning may be required depending on location.

C. Preparing the Icemaker for Long Storage

CAUTION

1. When storing the icemaker for an extended time or in sub-freezing temperatures, follow the instructions below to prevent damage.
2. To prevent damage to the water pump, do not leave the control switch in the "SERVICE" position for extended periods of time when the water tank is empty.

When the icemaker is not used for two or three days under normal conditions, it is sufficient to move the control switch to the "OFF" position. When storing the icemaker for an extended time or in sub-freezing temperatures, follow the instructions below.

1. Remove the water from the icemaker water supply line:

- 1) Turn off the power supply, then remove the front panel.
- 2) Move the control switch on the control box to the "OFF" position.
- 3) Close the icemaker water supply line shut-off valve, then open the icemaker water supply line drain valve.
- 4) Allow the line to drain by gravity.
- 5) Attach compressed air or carbon dioxide supply to the icemaker water supply line drain valve.
- 6) Move the control switch to the "ICE" position.
- 7) Replace the front panel in its correct position, then turn on the power supply.
- 8) Blow the icemaker water supply line out using compressed air or carbon dioxide.

2. Drain the water tank:

- 1) Turn off the power supply, then remove the front panel.
- 2) Move the service switch to the "DRAIN" position, then move the control switch to the "SERVICE" position.
- 3) Replace the front panel in its correct position, then turn on the power supply for 2 minutes.
- 4) Turn off the power supply, then remove the front panel.
- 5) Move the control switch to the "OFF" position.
- 6) Replace the front panel in its correct position.
- 7) Remove all ice from the dispenser unit/storage bin. Clean the dispenser unit/storage bin using a neutral cleaner. Rinse thoroughly after cleaning.
- 8) Close the icemaker water supply line drain valve.

3. On water-cooled model, remove the water from the water-cooled condenser:

- 1) Make sure the power supply is off, then remove the front panel and right side panel.
- 2) Close the condenser water supply line shut-off valve. If connected to a closed loop system, also close the condenser return line shut-off valve.

- 3) Open the condenser water supply line drain valve. If connected to a closed loop system, also open the condenser return line drain valve.
- 4) Attach a compressed air or carbon dioxide supply to the condenser water supply line drain valve.
- 5) Open the water regulating valve by using a screwdriver to pry up on the spring retainer underneath the spring. While holding the valve open, blow out the condenser using the compressed air or carbon dioxide supply until water stops coming out.
- 6) Close the drain valve(s).
- 7) Replace the right side panel and front panel in their correct positions.