

# d) KML-631MRH - D-1 and Later (Crankcase Heater Relay)

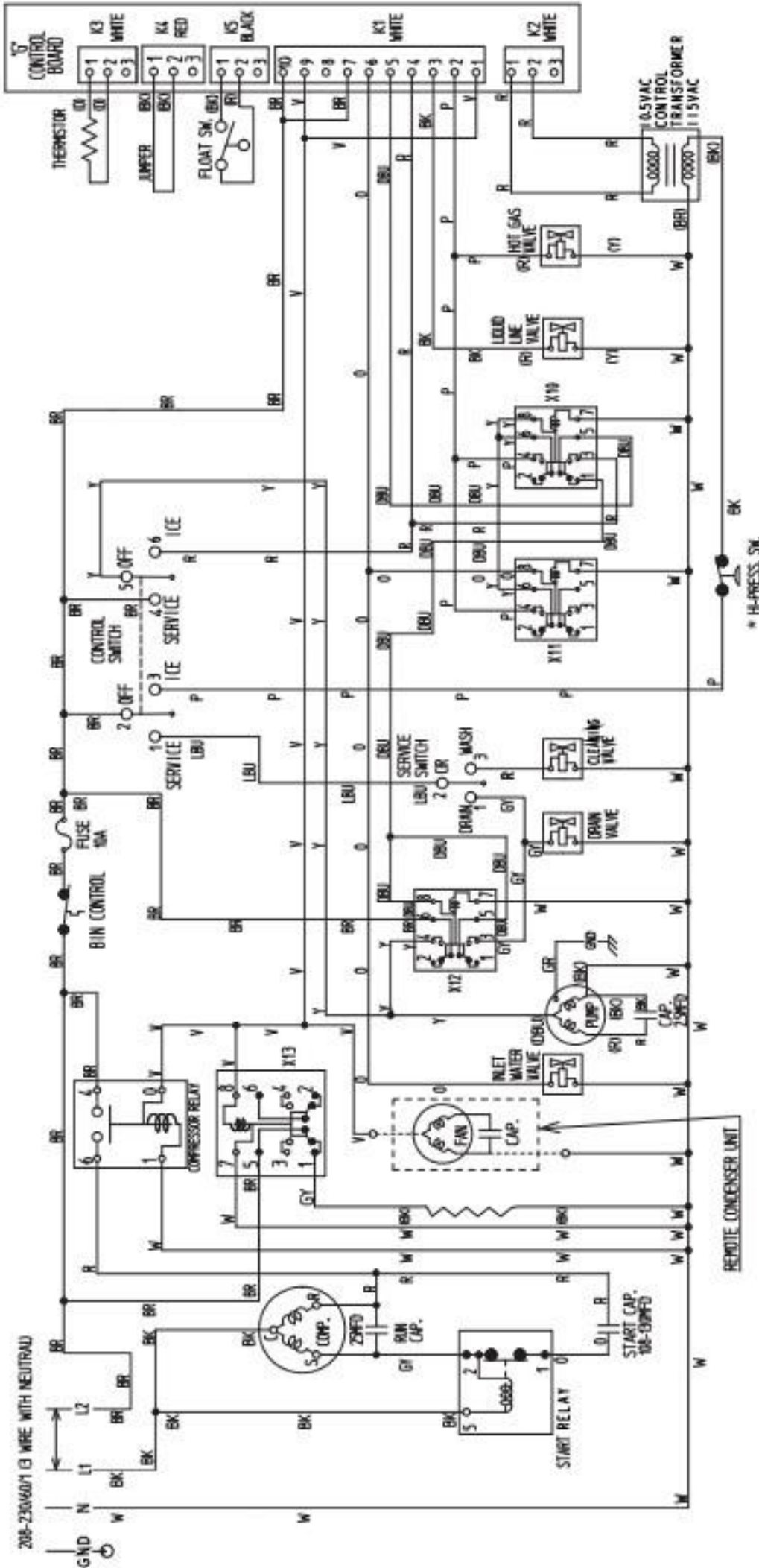

### WIRE COLOR CODE

BK	BLACK	R	RED
BR	BROWN	V	VIOLET
DBU	DARK BLUE	W	WHITE
GR	GREEN	Y	YELLOW
GY	GRAY	W/BK	WHITE/BLACK
LBU	LIGHT BLUE	W/BR	WHITE/BROWN
O	ORANGE	W/BU	WHITE/BLUE
P	PINK	W/O	WHITE/ORANGE
		W/R	WHITE/RED

X10	PUMP MOTOR RELAY
X11	INLET WATER VALVE RELAY
X12	SERVICE RELAY
X13	CRANKCASE HEATER RELAY

MODEL	S5 DP SWITCH SETTINGS				
	1	2	3	4	5
KML-631MRH	OFF	OFF	OFF	OFF	OFF

MODEL	S4 DP SWITCH SETTINGS									
	1	2	3	4	5	6	7	8	9	10
KML-631MRH	OFF	OFF	OFF	OFF	ON	ON	ON	OFF	OFF	ON

* High-Pressure Switch	
Remote Air-Cooled Model	
Cut-out	412 $\pm$ 21.3 PSIG
Cut-in	327 $\pm$ 21.3 PSIG

c) KML-631MRH - C-1 to D-0 (No Crankcase Heater Relay)

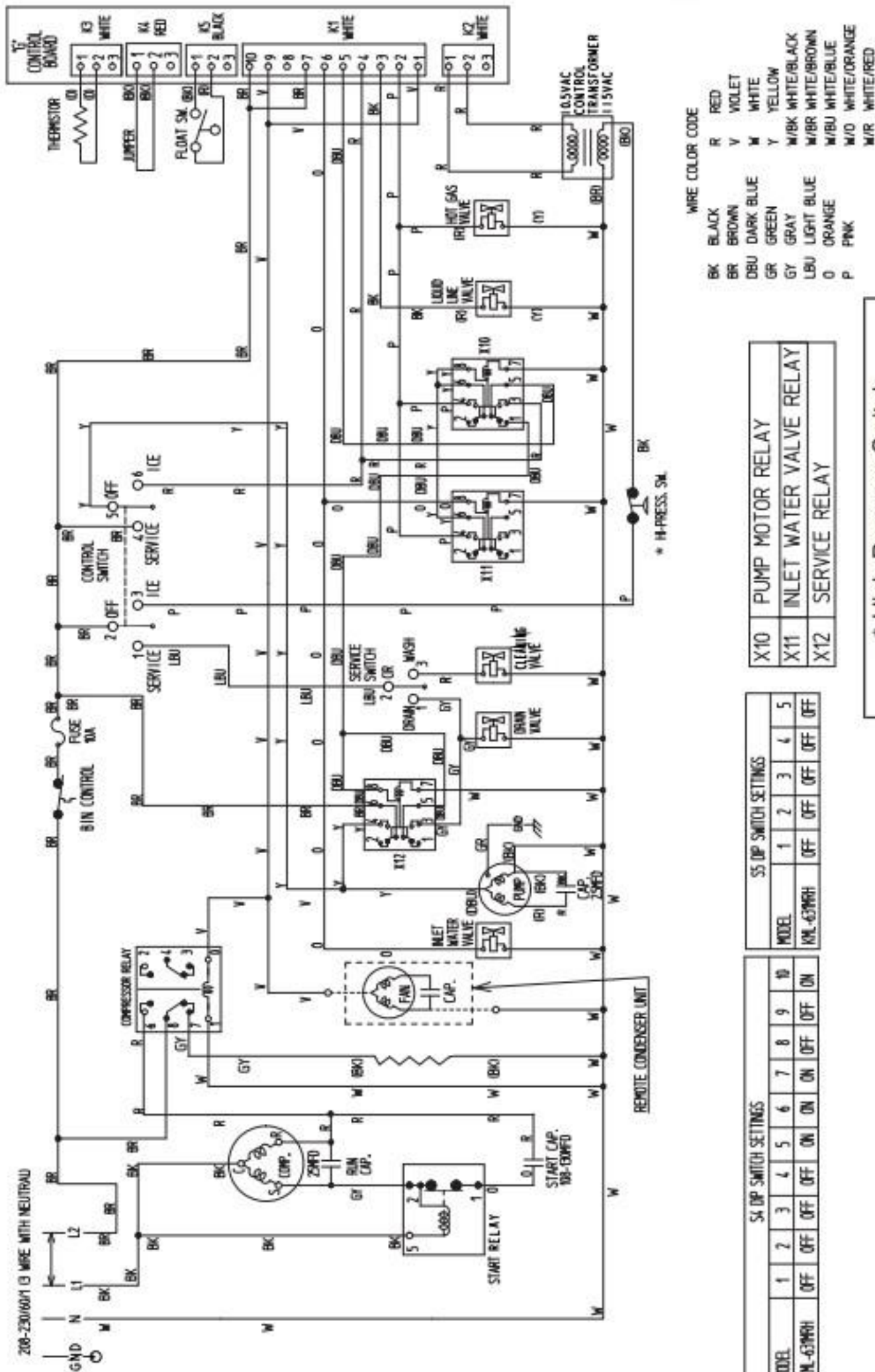

X10	PUMP MOTOR RELAY
X11	INLET WATER VALVE RELAY
X12	SERVICE RELAY

S5 DP SWITCH SETTINGS					
MODEL	1	2	3	4	5
KML-631MRH	OFF	OFF	OFF	OFF	OFF

S4 DP SWITCH SETTINGS										
MODEL	1	2	3	4	5	6	7	8	9	10
KML-631MRH	OFF	OFF	OFF	OFF	ON	ON	ON	OFF	OFF	ON

* High-Pressure Switch	
Remote Air-Cooled Model	
Cut-out	412±21.3 PSIG
Cut-in	327±21.3 PSIG

208-230/60V 13 WIRE WITH NEUTRAL

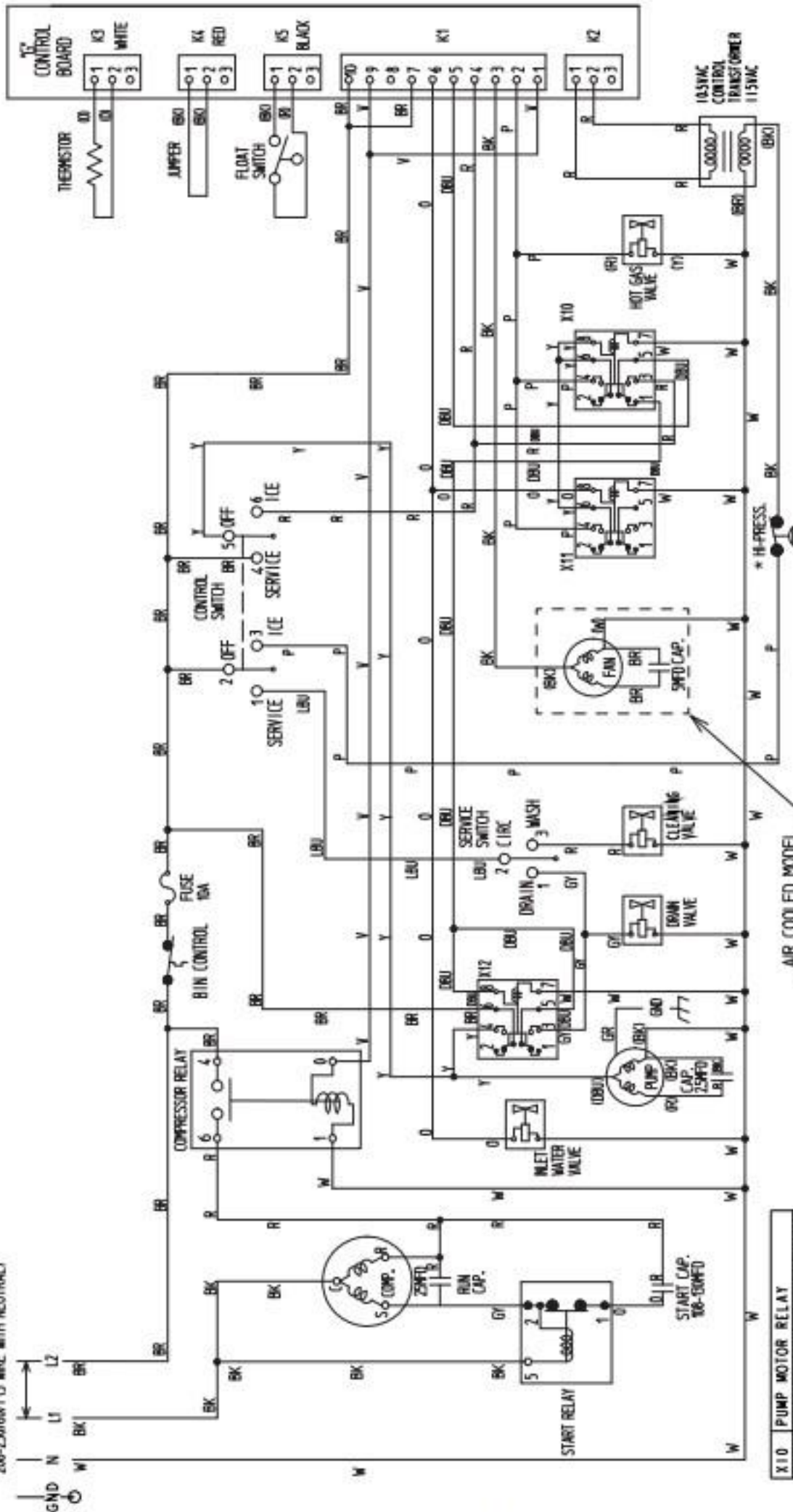

X10	PUMP MOTOR RELAY
X11	INLET WATER VALVE RELAY
X12	SERVICE RELAY

S4 DP SWITCH SETTING										
MODEL	1	2	3	4	5	6	7	8	9	10
KML-63PMH	OFF	OFF	OFF	ON	ON	ON	ON	OFF	OFF	ON
KML-63PMH	OFF	OFF	OFF	ON	ON	ON	ON	OFF	OFF	ON

S5 DP SWITCH SETTING					
MODEL	1	2	3	4	5
KML-63PMH	OFF	OFF	OFF	OFF	OFF
KML-63PMH	OFF	OFF	OFF	OFF	OFF

\* High-Pressure Switch

	Air-Cooled Model	Water-Cooled Model
Cut-out	412±21.3 PSIG	384±21.3 PSIG
Cut-in	327±21.3 PSIG	284±21.3 PSIG

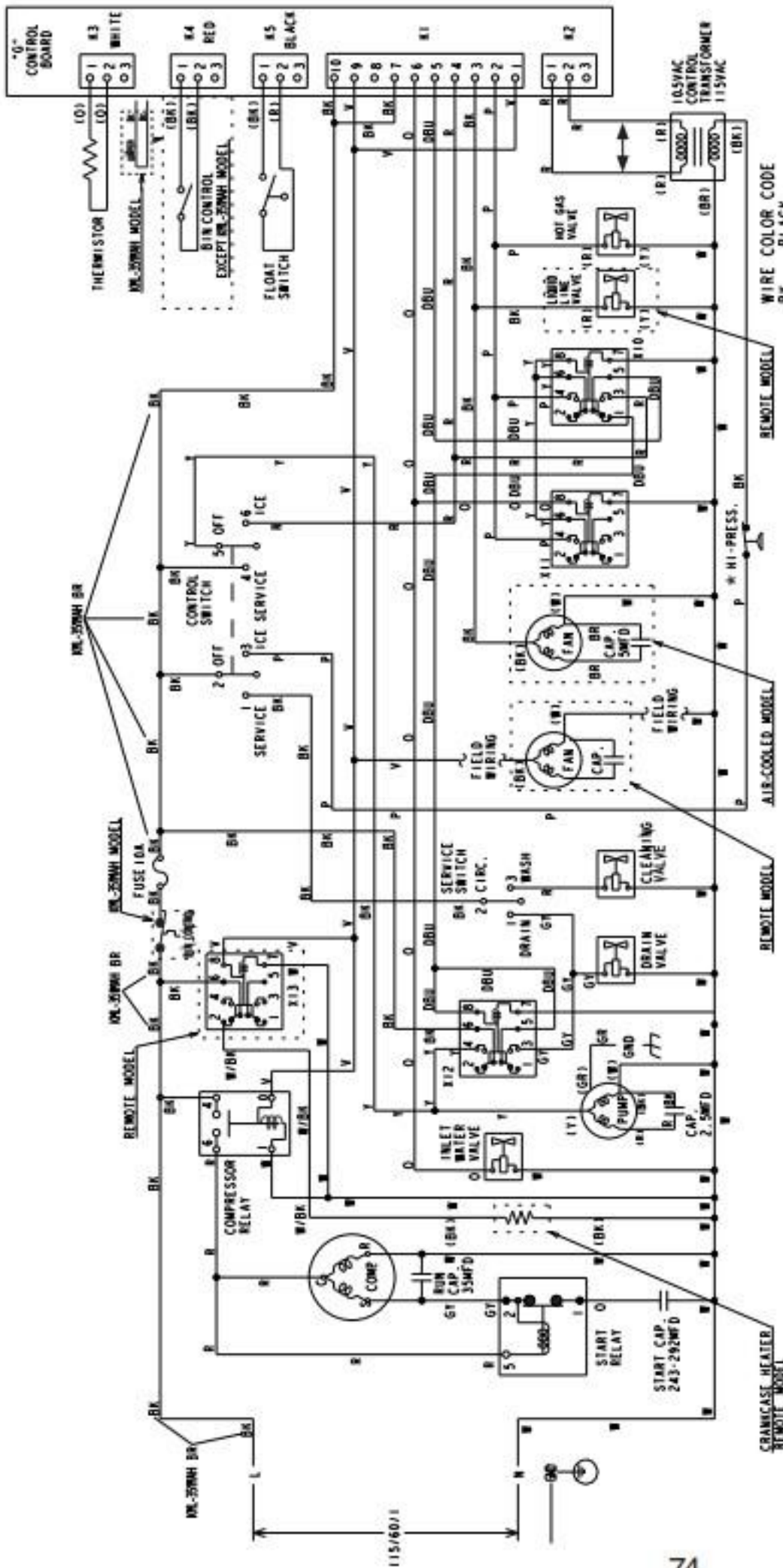

**WIRE COLOR CODE**  
 BK BLACK  
 BR BROWN  
 DBU DARK BLUE  
 GR GREEN  
 GY GRAY  
 LBU LIGHT BLUE  
 O ORANGE  
 P PINK  
 R RED  
 V VIOLET  
 W WHITE  
 Y YELLOW

**55 DIP SWITCH SETTING**

MODEL	1	2	3	4	5
ALL	OFF	OFF	OFF	OFF	OFF

**S4 DIP SWITCH SETTING**

MODEL	1	2	3	4	5	6	7	8	9	10
KML-350MAH	OFF	OFF	OFF	OFF	OFF	ON	ON	OFF	OFF	ON
RMD-460MAH	OFF	OFF	OFF	OFF	ON	ON	ON	OFF	OFF	OFF
RMD-460MRH	OFF	OFF	OFF	OFF	ON	ON	ON	OFF	OFF	OFF
RMD-530MAH	OFF	OFF	OFF	OFF	ON	ON	ON	OFF	OFF	OFF
RMD-530MRH	OFF	OFF	OFF	OFF	ON	ON	ON	OFF	OFF	OFF
RMD-530MRH	OFF	OFF	OFF	OFF	ON	ON	ON	OFF	OFF	OFF

**S4 DIP SWITCH SETTING**

MODEL	1	2	3	4	5	6	7	8	9	10
KML-350MAH	OFF	OFF	OFF	OFF	OFF	ON	ON	OFF	OFF	ON
RMD-460MAH	OFF	OFF	OFF	OFF	ON	ON	ON	OFF	OFF	OFF
RMD-460MRH	OFF	OFF	OFF	OFF	ON	ON	ON	OFF	OFF	OFF
RMD-530MAH	OFF	OFF	OFF	OFF	ON	ON	ON	OFF	OFF	OFF
RMD-530MRH	OFF	OFF	OFF	OFF	ON	ON	ON	OFF	OFF	OFF
RMD-530MRH	OFF	OFF	OFF	OFF	ON	ON	ON	OFF	OFF	OFF

**\* High-Pressure Switch**

	Air-Cooled and Remote Air-Cooled Models	Water-Cooled Model
Cut-out	412±21.3 PSIG	384±21.3 PSIG
Cut-in	327±21.3 PSIG	284±21.3 PSIG

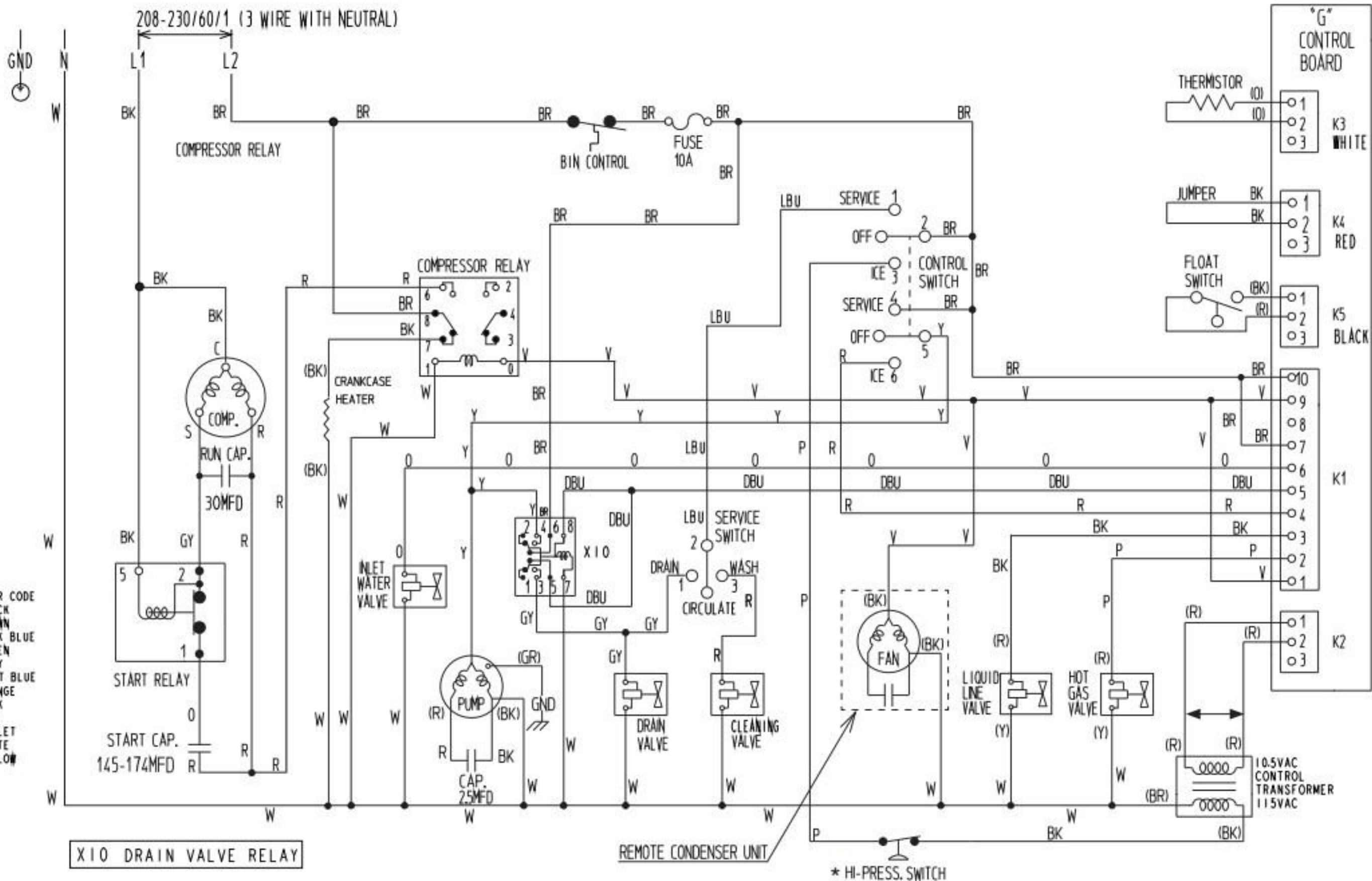

S4 DIP SWITCH SETTING										
MODEL	1	2	3	4	5	6	7	8	9	10
KML-631MRH	ON	OFF	OFF	OFF	ON	ON	OFF	OFF	OFF	ON

S5 DIP SWITCH SETTING				
1	2	3	4	5
OFF	OFF	OFF	OFF	OFF

* High-Pressure Switch	
Remote Air-Cooled Model	
Cut-out	412 $\pm$ <sub>0</sub> <sup>21.3</sup> PSIG
Cut-in	327 $\pm$ 21.3 PSIG

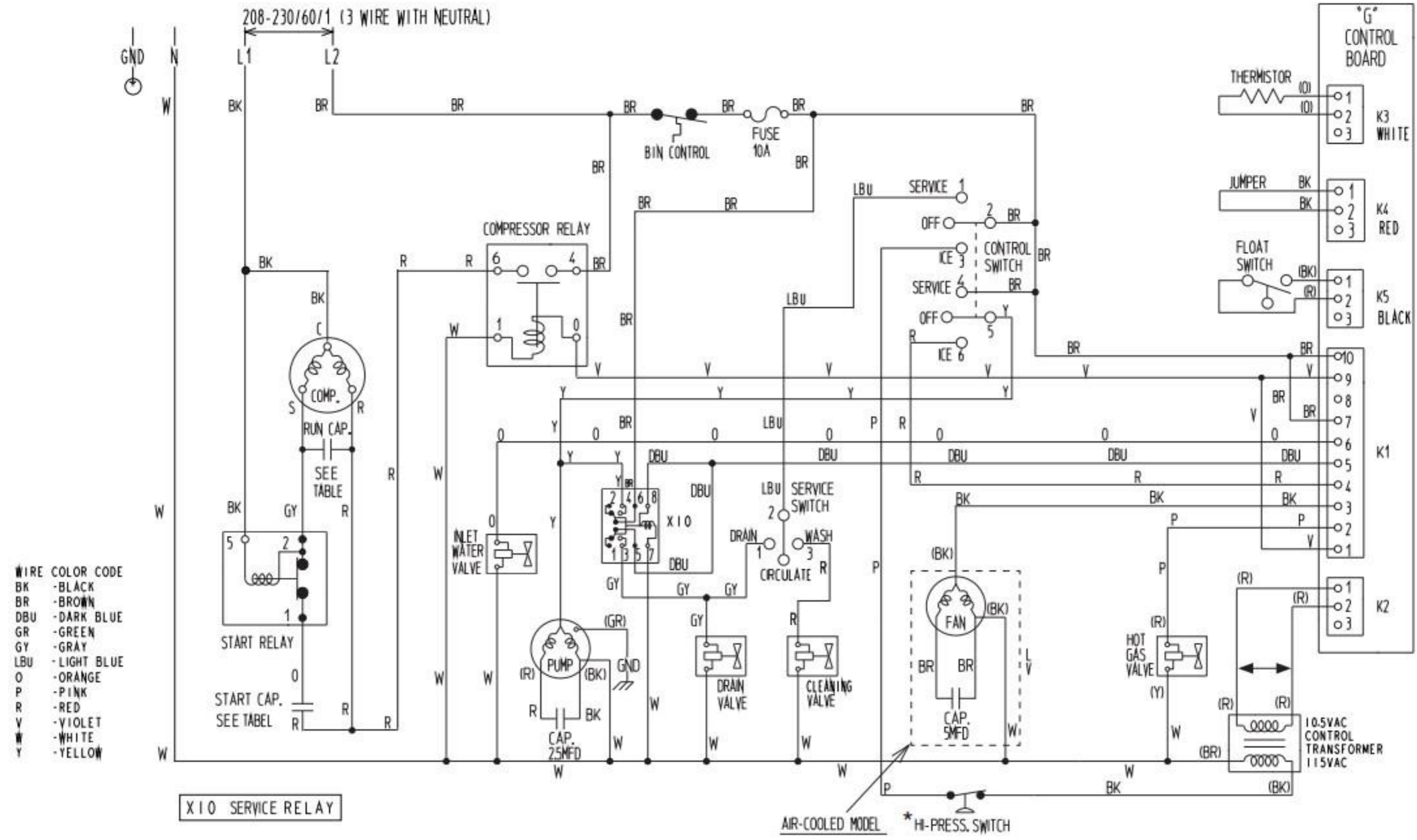

COMP. RUN/START CAP. TABLE

MODEL	AUX. CODE	RUN CAP.	START CAP.
KML-631MAH	ALL	30MFD	145-174MFD
KML-631MWH			

S4 DIP SWITCH SETTING

MODEL	1	2	3	4	5	6	7	8	9	10
ALL	ON	OFF	OFF	OFF	ON	ON	OFF	OFF	OFF	ON

S5 DIP SWITCH SETTING

MODEL	1	2	3	4	5
ALL	OFF	OFF	OFF	OFF	OFF

\* High-Pressure Switch

	Air-Cooled Model	Water-Cooled Model
Cut-out	412± <sup>21.3</sup> <sub>0</sub> PSIG	384± <sup>21.3</sup> <sub>0</sub> PSIG
Cut-in	327±21.3 PSIG	284±21.3 PSIG

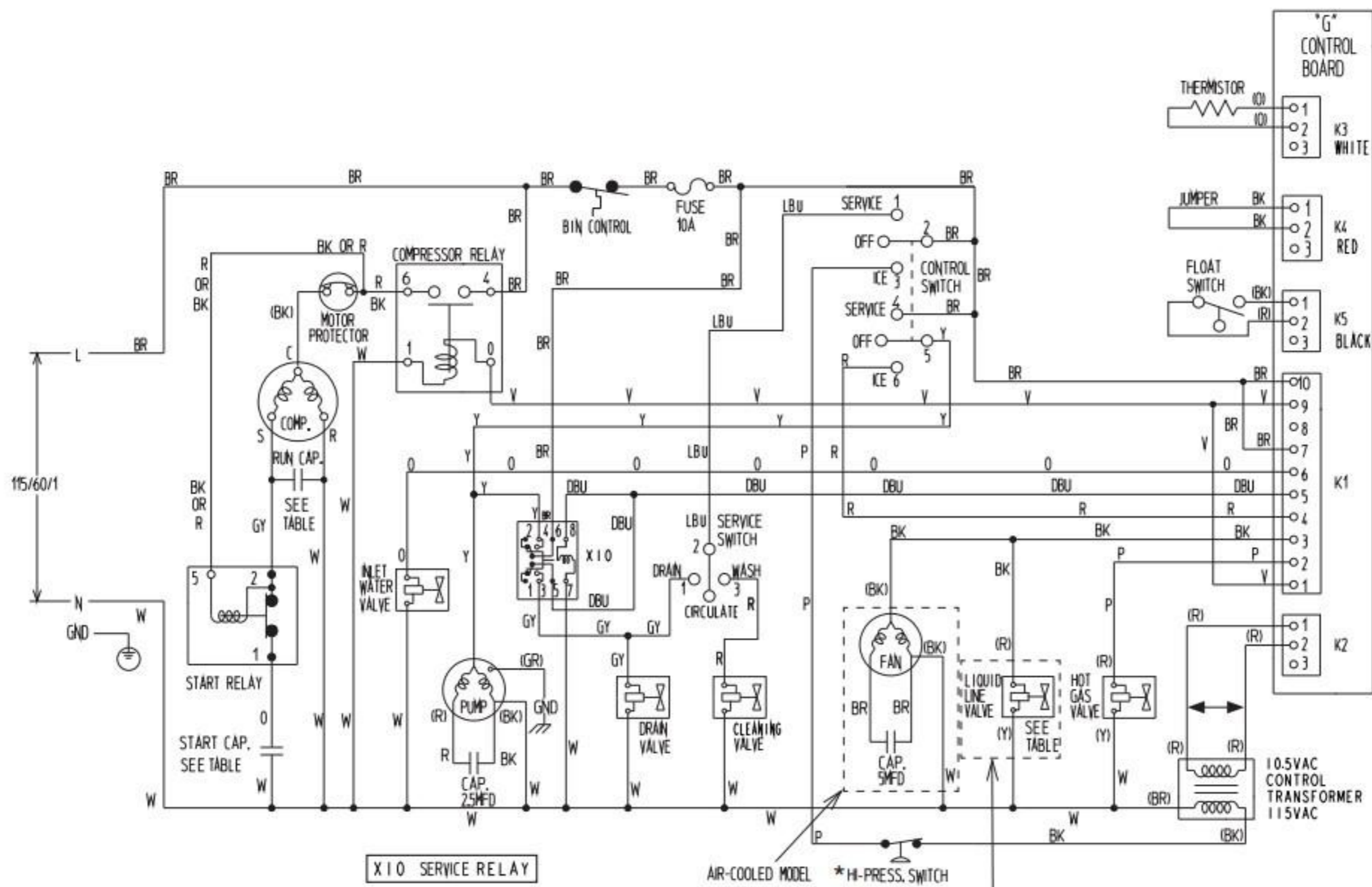

- WIRE COLOR CODE
- BK -BLACK
  - BR -BROWN
  - DBU -DARK BLUE
  - GR -GREEN
  - GY -GRAY
  - LBU -LIGHT BLUE
  - O -ORANGE
  - P -PINK
  - R -RED
  - V -VIOLET
  - W -WHITE
  - Y -YELLOW

S4 DIP SWITCH SETTING											
MODEL	AUX.CODE	1	2	3	4	5	6	7	8	9	10
KML-250MAH	B-1 and Later	OFF	OFF	OFF	ON	ON	ON	OFF	OFF	ON	OFF
KML-250MWH	B-1 and Later	OFF	OFF	OFF	ON	ON	ON	OFF	OFF	OFF	ON
KML-351MWH	C-1 and Later	ON	OFF	ON	ON	OFF	OFF	OFF	OFF	OFF	ON
KML-451MAH	B-1 and Later	OFF	OFF	OFF	OFF	OFF	OFF	OFF	OFF	OFF	ON
KML-451MWH	B-1 and Later	ON	OFF	OFF	OFF	ON	ON	OFF	OFF	OFF	ON

S5 DIP SWITCH SETTING					
MODEL	1	2	3	4	5
ALL	OFF	OFF	OFF	OFF	OFF

LIQUID LINE VALVE	
MODEL	AUX.CODE
KML-250M_H	ALL
KML-351MWH	

COMP. RUN / START CAP. TABLE			
MODEL	AUX.CODE	RUN CAP.	START CAP.
KML-250MAH	ALL	20MFD	72-86MFD
KML-250MWH			
KML-351MWH			
KML-351MAH	SEE PARTS LIST		
KML-451MAH	R-0,T-0, T-2,U-0	15MFD, 370VAC	243-292MFD, 115VAC
KML-451MWH	T-1, U-1 AND LATER	35MFD, 440 VAC	243-292MFD, 165VAC

*High-Pressure Switch		
	Air-Cooled Model	Water-Cooled Model
Cut-out	412± <sup>21.3</sup> <sub>0</sub> PSIG	384± <sup>21.3</sup> <sub>0</sub> PSIG
Cut-in	327±21.3 PSIG	284±21.3 PSIG