

| S4 DIP SWITCH SETTINGS | | | | | | | | | | |
|------------------------|-----|---|---|---|----|-----|----|---|-----|----|
| MODEL | 1 | 2 | 3 | 4 | 5 | 6 | 7 | 8 | 9 | 10 |
| KM-2200S_J3 | | | | | | | | | | |
| KM-2600S_J3 | OFF | | | | ON | OFF | ON | | OFF | |
| KM-1900S_J3 | | | | | | | | | | |

| S5 DIP SWITCH SETTINGS | | | | | |
|------------------------|-----|---|---|---|----|
| MODEL | 1 | 2 | 3 | 4 | 5 |
| KM-2200S_J3 | | | | | |
| KM-2600S_J3 | OFF | | | | ON |
| KM-1900S_J3 | | | | | |

| | |
|-----|----------------------|
| X10 | PUMP DIRECTION RELAY |
| X11 | X10 CONTROL RELAY |
| X12 | SLUSH CONTROL RELAY |

- WIRE COLOR CODE
- BK BLACK
 - BR BROWN
 - DBU DARK BLUE
 - GR GREEN
 - GY GRAY
 - LBU LIGHT BLUE
 - O ORANGE
 - P PINK
 - R RED
 - V VIOLET
 - W WHITE
 - Y YELLOW
 - W/BK WHITE/BLACK
 - W/BR WHITE/BROWN
 - W/BU WHITE/BLUE
 - W/O WHITE/ORANGE
 - W/R WHITE/RED

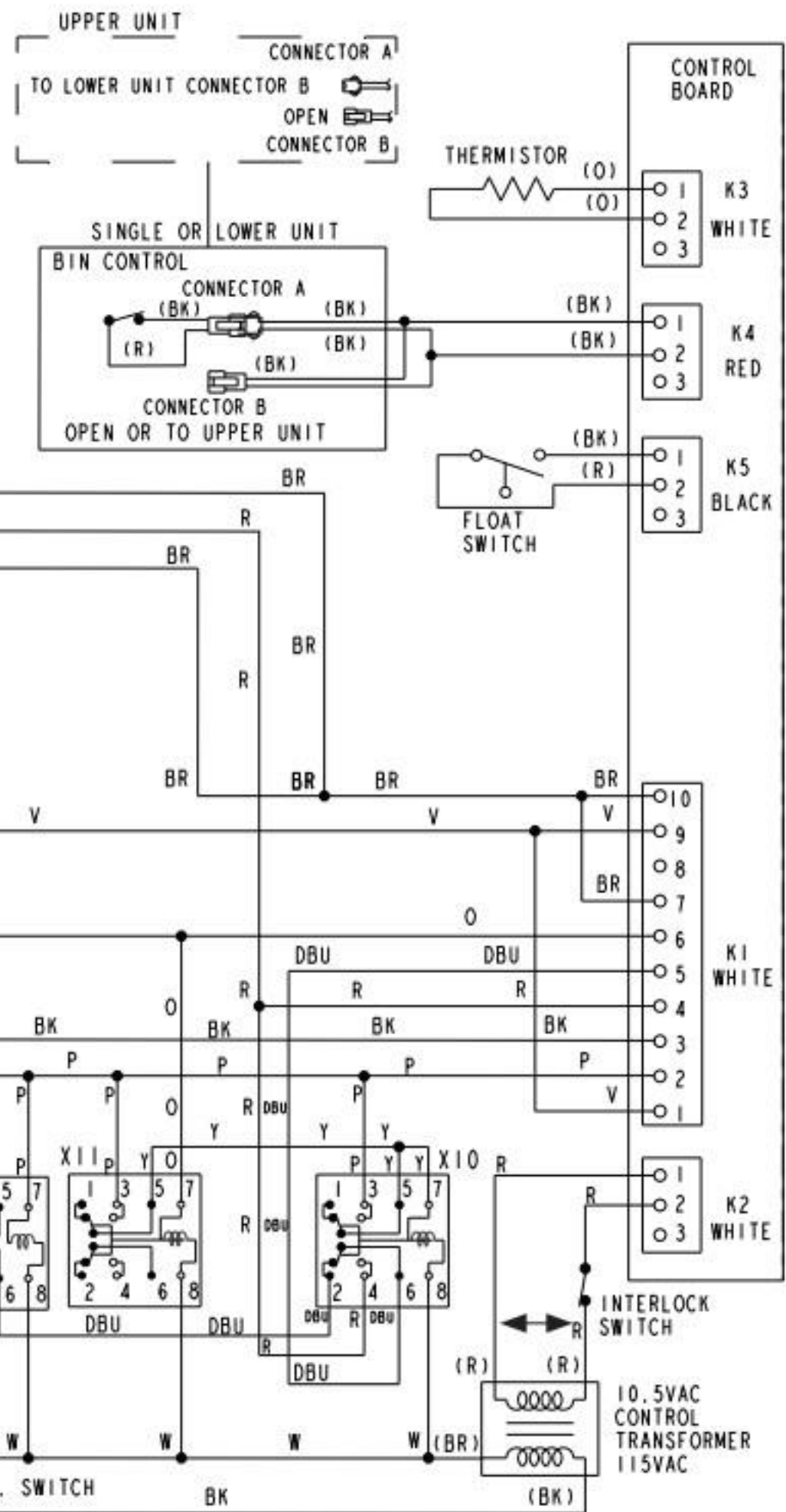
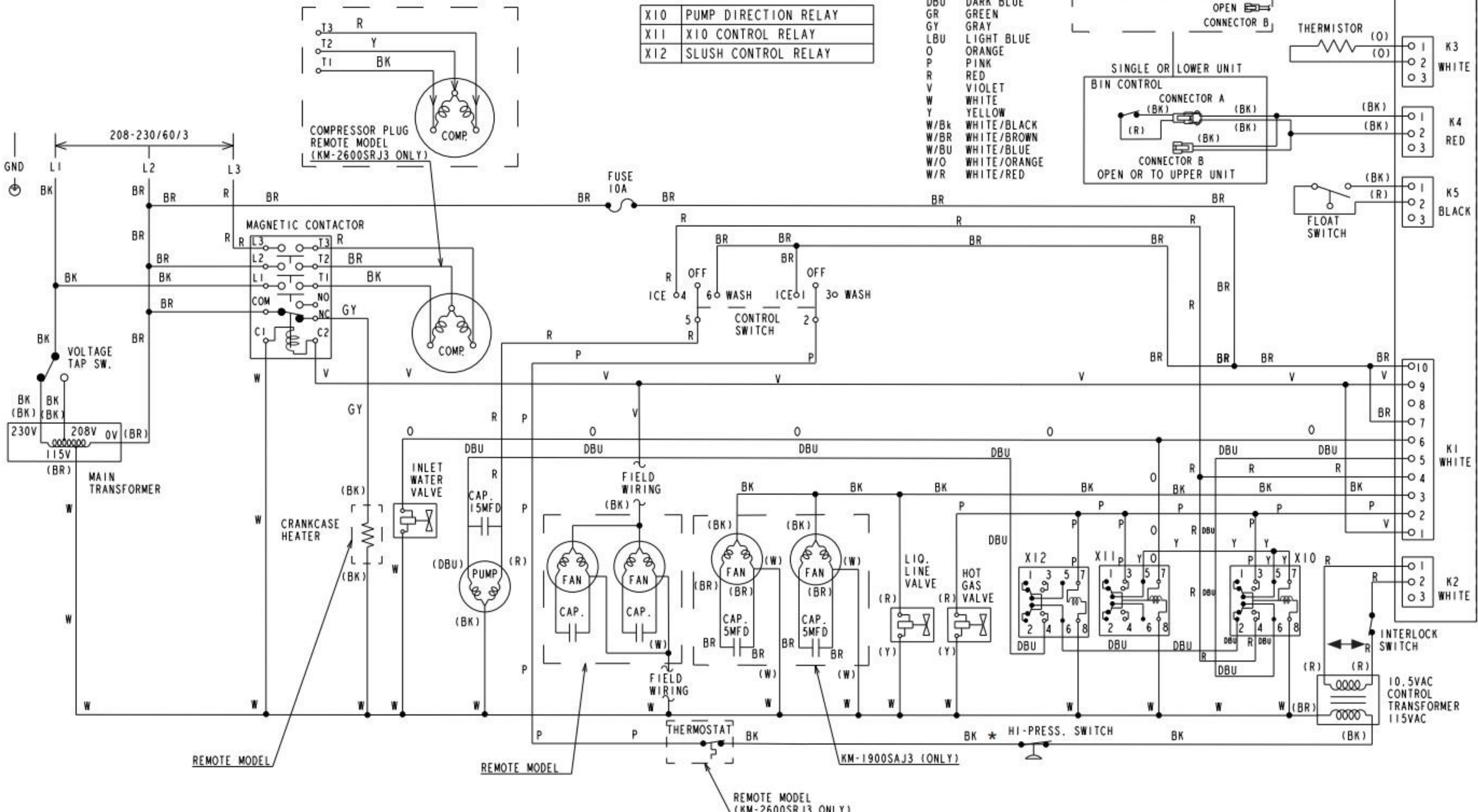

| S4 DIP SWITCH SETTINGS | | | | | | | | | | |
|------------------------|----|---|---|-----|---|---|---|----|---|-----|
| MODEL | 1 | 2 | 3 | 4 | 5 | 6 | 7 | 8 | 9 | 10 |
| KM-1601SAJ3 | | | | | | | | | | |
| KM-1601SWJ3 | ON | | | OFF | | | | ON | | OFF |
| KM-1601SRJ3 | | | | | | | | | | |

| S5 DIP SWITCH SETTINGS | | | | | |
|------------------------|---|---|-----|---|----|
| MODEL | 1 | 2 | 3 | 4 | 5 |
| KM-1601SAJ3 | | | | | |
| KM-1601SWJ3 | | | OFF | | ON |
| KM-1601SRJ3 | | | | | |

| | |
|-----|----------------------|
| X10 | PUMP DIRECTION RELAY |
| X11 | X10 CONTROL RELAY |
| X12 | SLUSH CONTROL RELAY |

WIRE COLOR CODE
 BK BLACK
 BR BROWN
 DBU DARK BLUE
 GR GREEN
 GY GRAY
 LBU LIGHT BLUE
 O ORANGE
 P PINK
 R RED
 V VIOLET
 W WHITE
 Y YELLOW
 W/BK WHITE/BLACK
 W/BR WHITE/BROWN
 W/BU WHITE/BLUE
 W/O WHITE/ORANGE
 W/R WHITE/RED

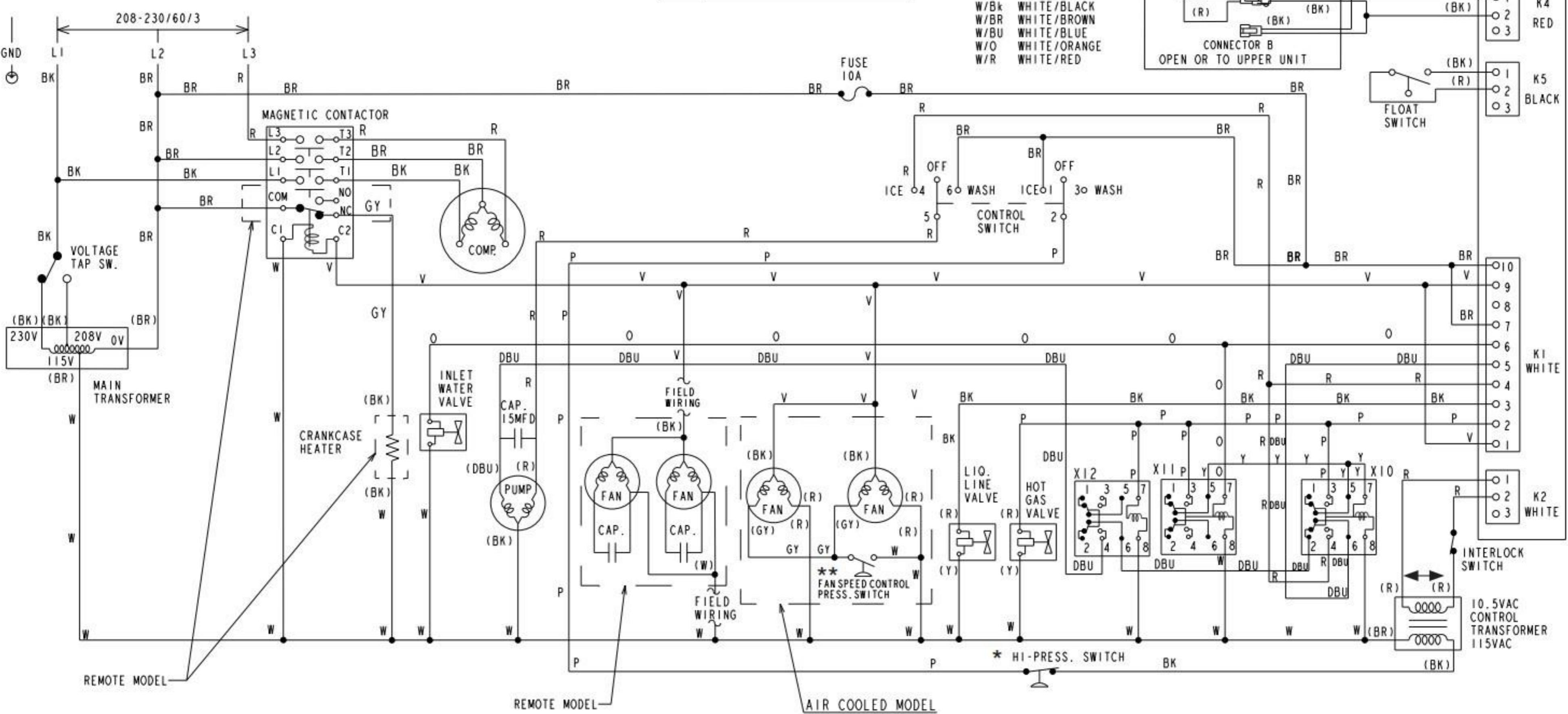
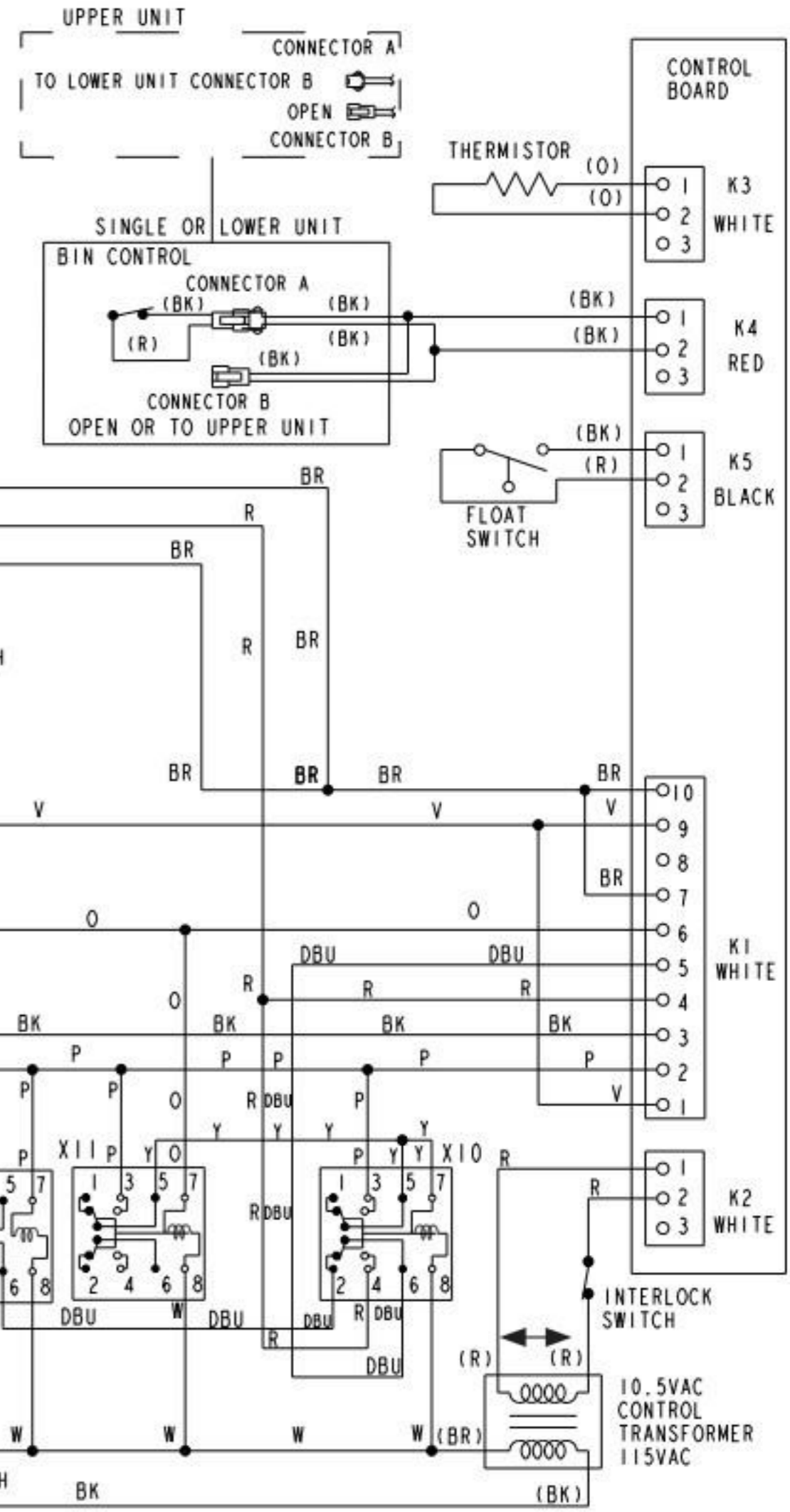

| S4 DIP SWITCH SETTINGS | | | | | | | | | | |
|------------------------|---|-----|---|---|---|---|----|---|-----|----|
| MODEL | 1 | 2 | 3 | 4 | 5 | 6 | 7 | 8 | 9 | 10 |
| KM-1301SAJ3 | | | | | | | | | | |
| KM-1301SWJ3 | | OFF | | | | | ON | | OFF | |
| KM-1301SRJ3 | | | | | | | | | | |

| S5 DIP SWITCH SETTINGS | | | | | |
|------------------------|---|-----|---|---|----|
| MODEL | 1 | 2 | 3 | 4 | 5 |
| KM-1301SAJ3 | | | | | |
| KM-1301SWJ3 | | OFF | | | ON |
| KM-1301SRJ3 | | | | | |

| | |
|-----|----------------------|
| X10 | PUMP DIRECTION RELAY |
| X11 | X10 CONTROL RELAY |
| X12 | SLUSH CONTROL RELAY |

WIRE COLOR CODE
 BK BLACK
 BR BROWN
 DBU DARK BLUE
 GR GREEN
 GY GRAY
 LBU LIGHT BLUE
 O ORANGE
 P PINK
 R RED
 V VIOLET
 W WHITE
 Y YELLOW
 W/BK WHITE/BLACK
 W/BR WHITE/BROWN
 W/BU WHITE/BLUE
 W/O WHITE/ORANGE
 W/R WHITE/RED

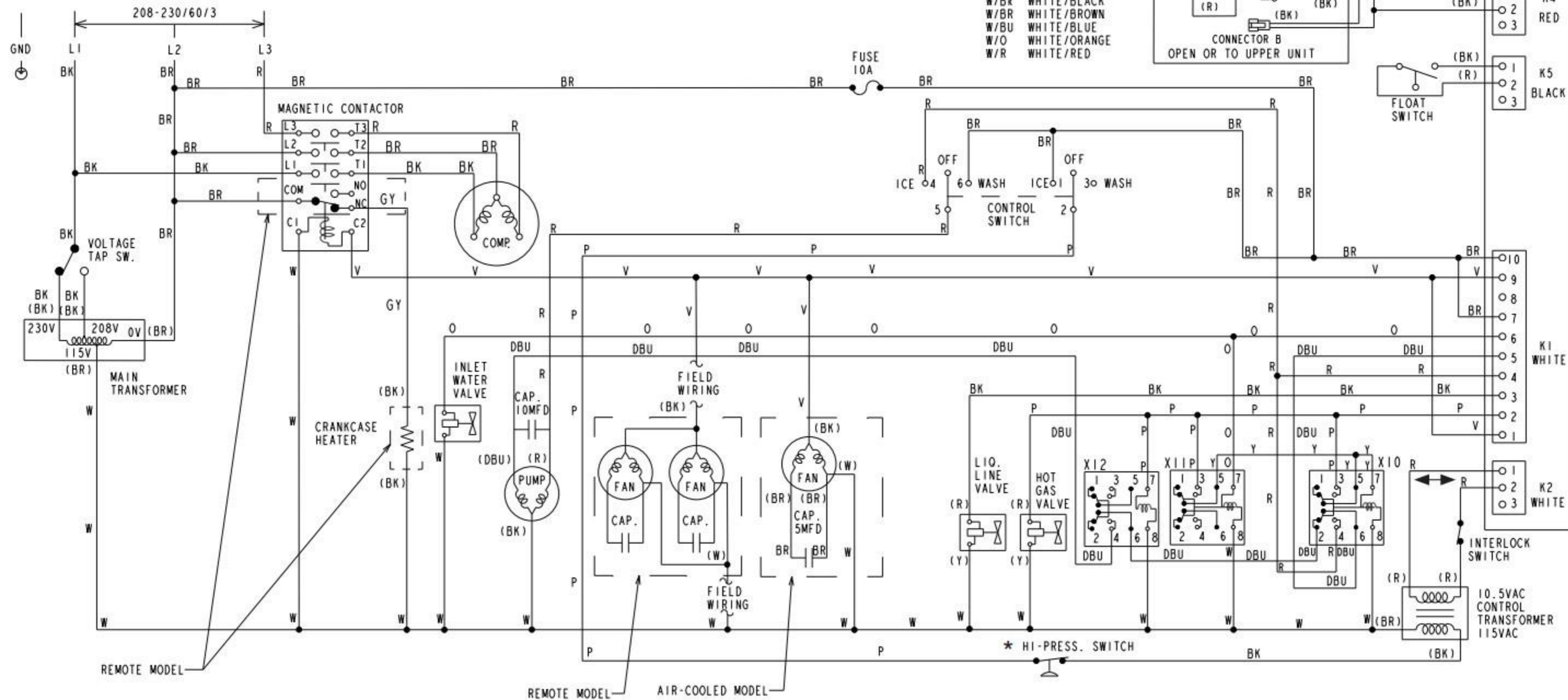
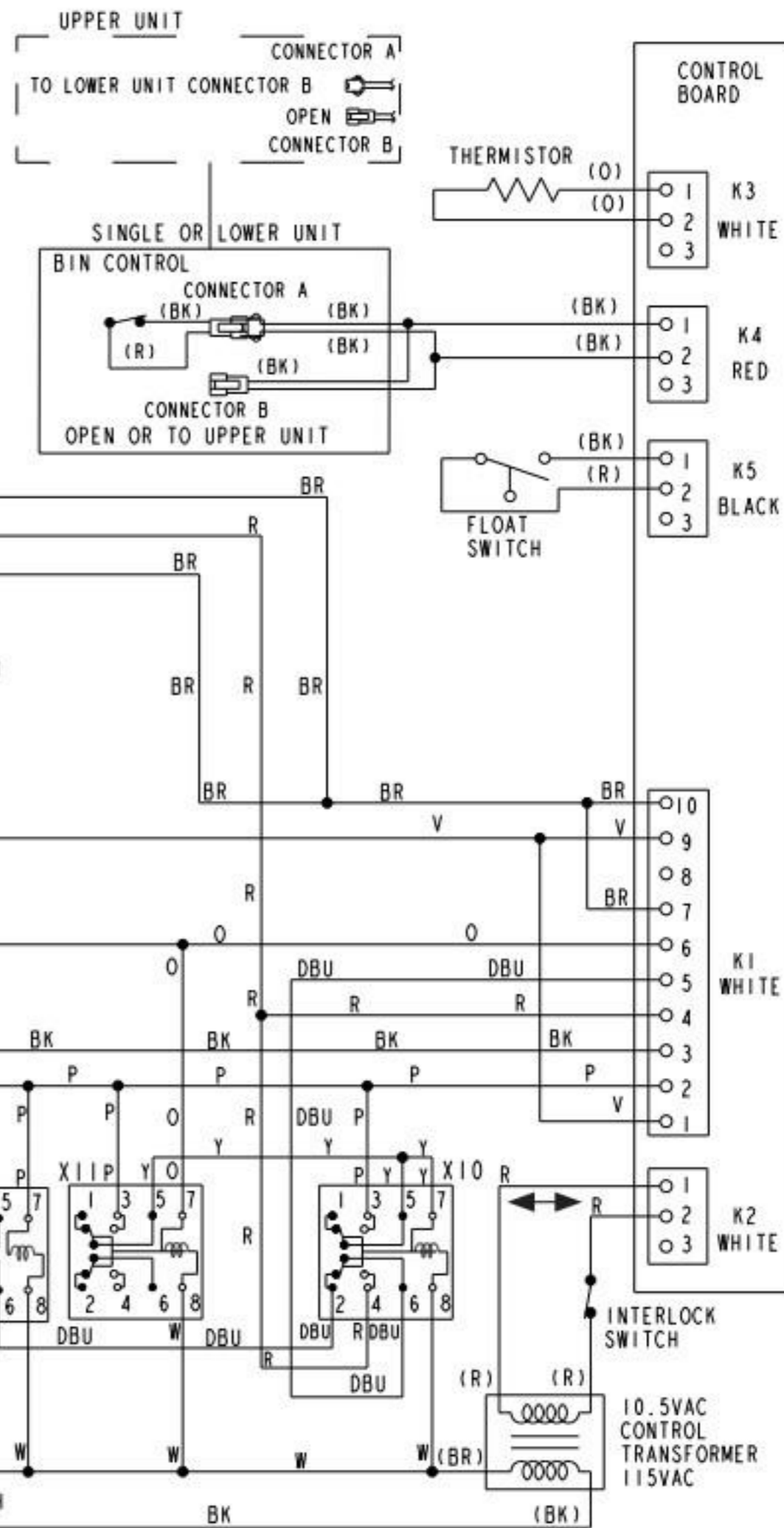

| S4 DIP SWITCH SETTINGS | | | | | | | | | | |
|------------------------|-----|---|---|---|----|-----|----|---|-----|----|
| MODEL | 1 | 2 | 3 | 4 | 5 | 6 | 7 | 8 | 9 | 10 |
| KM-1900SAJ | | | | | | | | | | |
| KM-1900SWJ | OFF | | | | ON | OFF | ON | | OFF | |
| KM-1900SRJ | OFF | | | | ON | OFF | ON | | OFF | |

| S5 DIP SWITCH SETTINGS | | | | | |
|------------------------|-----|---|---|---|----|
| MODEL | 1 | 2 | 3 | 4 | 5 |
| KM-1900SAJ | | | | | |
| KM-1900SWJ | OFF | | | | ON |
| KM-1900SRJ | OFF | | | | ON |

| | |
|-----|------------------------|
| X10 | PUMP DIRECTION RELAY |
| X11 | X10 CONTROL RELAY |
| X12 | SLUSH CONTROL RELAY |
| X13 | CRANKCASE HEATER RELAY |

WIRE COLOR CODE
 BK BLACK
 BR BROWN
 DBU DARK BLUE
 GR GREEN
 GY GRAY
 LBU LIGHT BLUE
 O ORANGE
 P PINK
 R RED
 V VIOLET
 W WHITE
 Y YELLOW
 W/BK WHITE/BLACK
 W/BR WHITE/BROWN
 W/BU WHITE/BLUE
 W/O WHITE/ORANGE
 W/R WHITE/RED

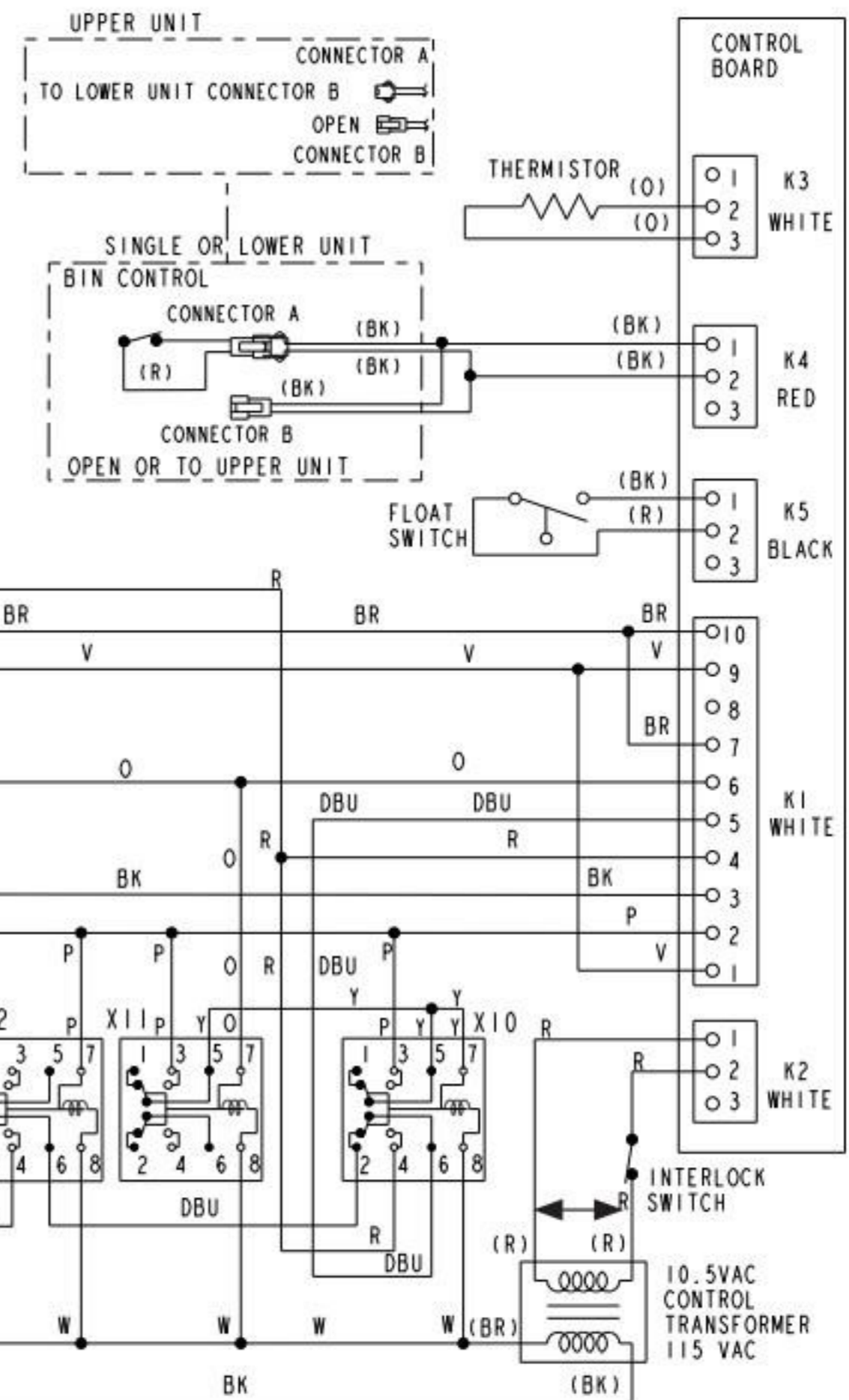
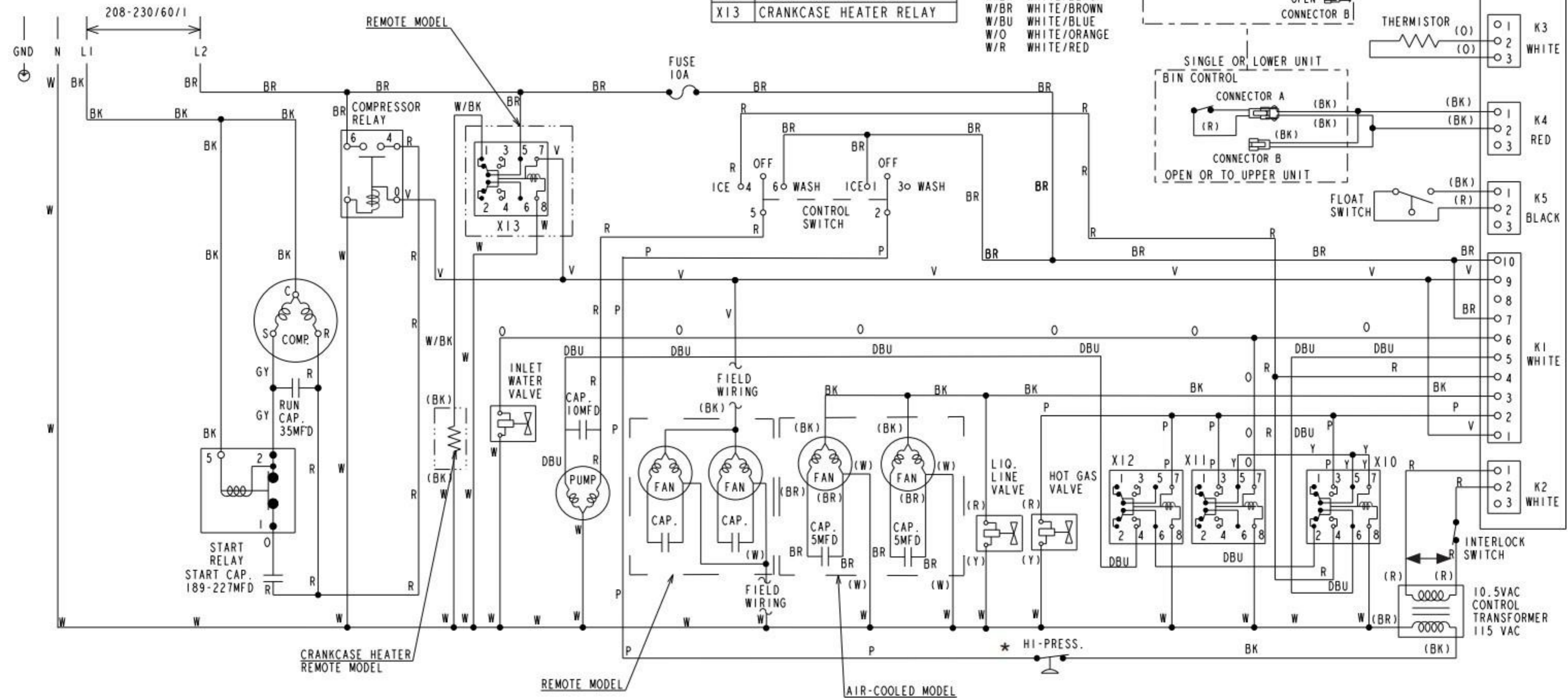

| S4 DIP SWITCH SETTINGS | | | | | | | | | | |
|------------------------|----|---|-----|---|---|---|----|---|-----|----|
| MODEL | 1 | 2 | 3 | 4 | 5 | 6 | 7 | 8 | 9 | 10 |
| KM-1601SAJ | | | | | | | | | | |
| KM-1601SWJ | ON | | OFF | | | | ON | | OFF | |
| KM-1601SRJ | | | | | | | | | | |

| S5 DIP SWITCH SETTINGS | | | | | |
|------------------------|---|---|-----|---|----|
| MODEL | 1 | 2 | 3 | 4 | 5 |
| KM-1601SAJ | | | | | |
| KM-1601SWJ | | | OFF | | |
| KM-1601SRJ | | | | | ON |

| | |
|-----|------------------------|
| X10 | PUMP DIRECTION RELAY |
| X11 | X10 CONTROL RELAY |
| X12 | SLUSH CONTROL RELAY |
| X13 | CRANKCASE HEATER RELAY |

| WIRE | COLOR CODE |
|------|--------------|
| BK | BLACK |
| BR | BROWN |
| DBU | DARK BLUE |
| GR | GREEN |
| GY | GRAY |
| LBU | LIGHT BLUE |
| O | ORANGE |
| P | PINK |
| R | RED |
| V | VIOLET |
| W | WHITE |
| Y | YELLOW |
| W/Bk | WHITE/BLACK |
| W/BR | WHITE/BROWN |
| W/BU | WHITE/BLUE |
| W/O | WHITE/ORANGE |
| W/R | WHITE/RED |

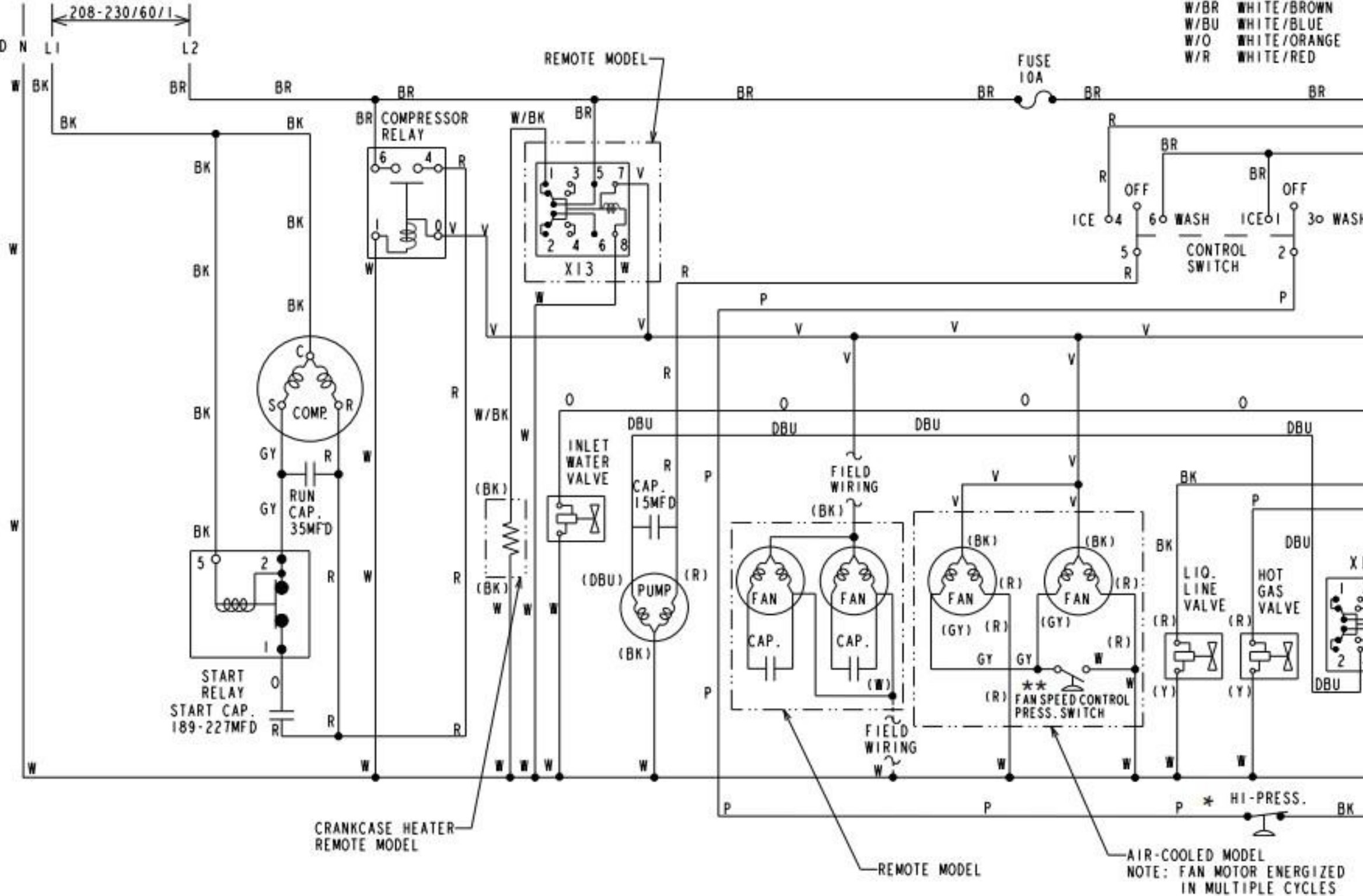
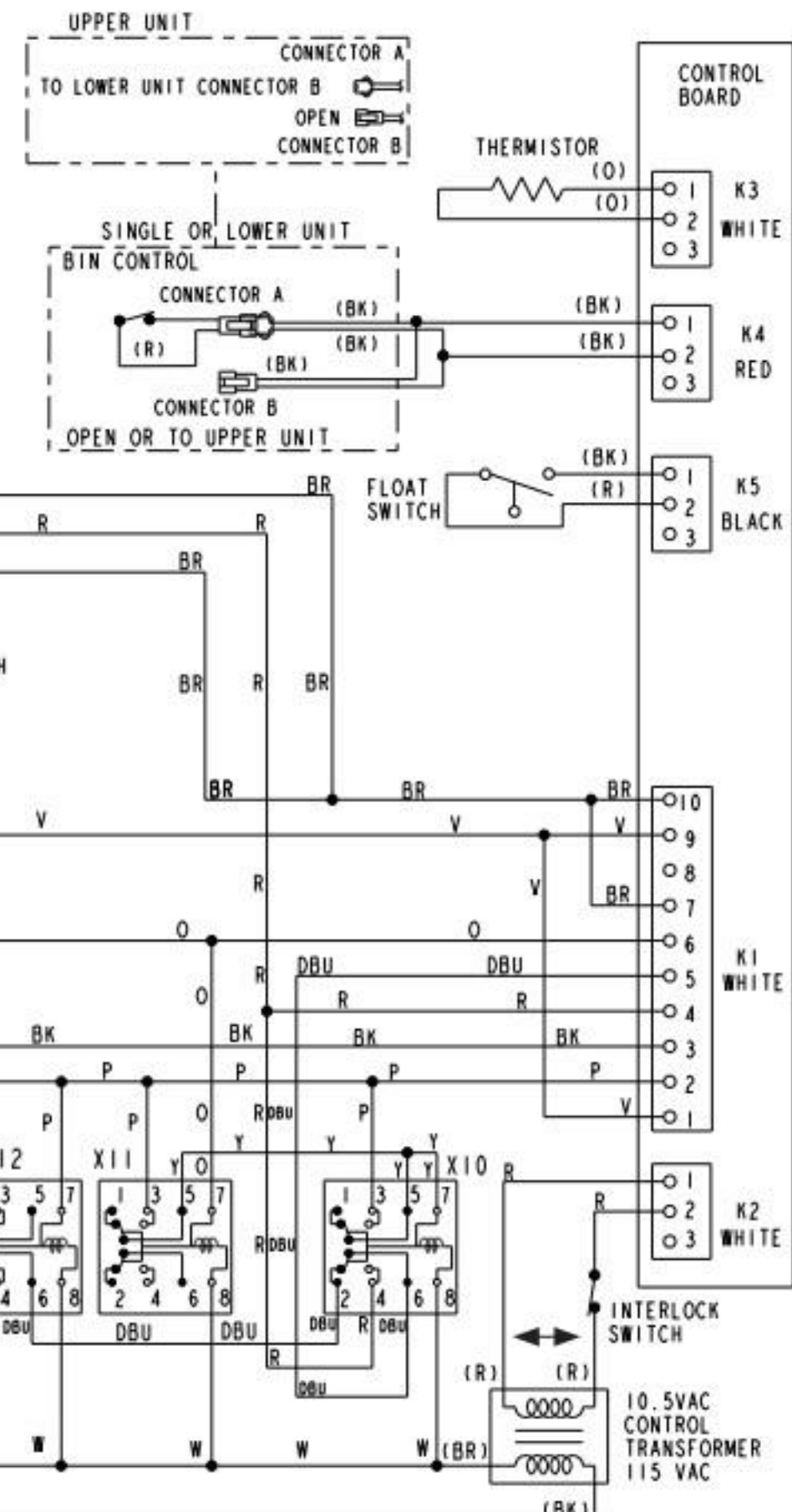

**** Fan Speed Control Pressure Switch**

| | High Pressure | RPMs |
|---------|---------------|------|
| Cut-out | 190±10 PSIG | 700 |
| Cut-in | 250±10 PSIG | 1600 |

*** High-Pressure Switch**

| | Water-Cooled Model | Remote Model |
|---------|--------------------------------------|--------------------------------------|
| Cut-out | 384± ²² ₀ PSIG | 412± ²² ₀ PSIG |
| Cut-in | 284±22 PSIG | 327±22 PSIG |

| S4 DIP SWITCH SETTINGS | | | | | | | | | | |
|------------------------|----|-----|-----|-----|-----|-----|----|-----|-----|-----|
| MODEL | 1 | 2 | 3 | 4 | 5 | 6 | 7 | 8 | 9 | 10 |
| KM-1301SAJ | ON | OFF | OFF | OFF | OFF | OFF | ON | OFF | OFF | OFF |
| KM-1301SWJ | ON | OFF | OFF | OFF | OFF | OFF | ON | OFF | OFF | OFF |
| KM-1301SRJ | ON | OFF | OFF | OFF | OFF | OFF | ON | OFF | OFF | OFF |

| S5 DIP SWITCH SETTINGS | | | | | |
|------------------------|-----|-----|-----|-----|----|
| MODEL | 1 | 2 | 3 | 4 | 5 |
| KM-1301SAJ | OFF | OFF | OFF | OFF | ON |
| KM-1301SWJ | OFF | OFF | OFF | OFF | ON |
| KM-1301SRJ | OFF | OFF | OFF | OFF | ON |

| WIRE | COLOR CODE |
|------|--------------|
| BK | BLACK |
| BR | BROWN |
| DBU | DARK BLUE |
| GR | GREEN |
| GY | GRAY |
| LBU | LIGHT BLUE |
| O | ORANGE |
| P | PINK |
| R | RED |
| V | VIOLET |
| W | WHITE |
| Y | YELLOW |
| W/BK | WHITE/BLACK |
| W/BR | WHITE/BROWN |
| W/BU | WHITE/BLUE |
| W/O | WHITE/ORANGE |
| W/R | WHITE/RED |

| | |
|-----|------------------------|
| X10 | PUMP DIRECTION RELAY |
| X11 | X10 CONTROL RELAY |
| X12 | SLUSH CONTROL RELAY |
| X13 | CRANKCASE HEATER RELAY |

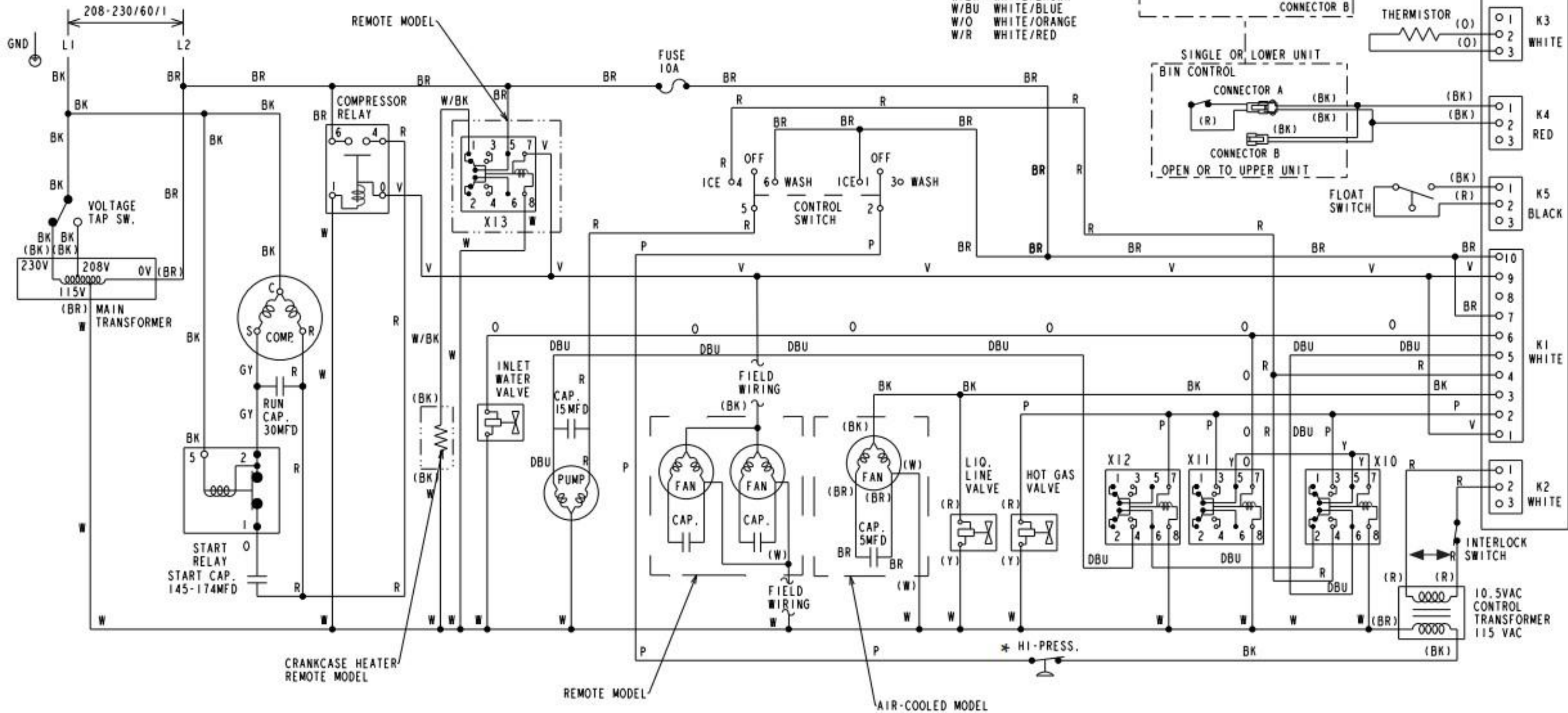

| * High-Pressure Switch | | |
|------------------------|--------------------|----------------------|
| | Water-Cooled Model | Air and Remote Model |
| Cut-out | 384±22 PSIG | 412±22 PSIG |
| Cut-in | 284±22 PSIG | 327±22 PSIG |