

hatcocorp.com

Register Online!
(see page 2)



FLAV-R-SAVOR®

Portable Holding Cabinet

Culver's FSHC-5W Series

Installation and Operating Manual

P/N 07.04.627.00

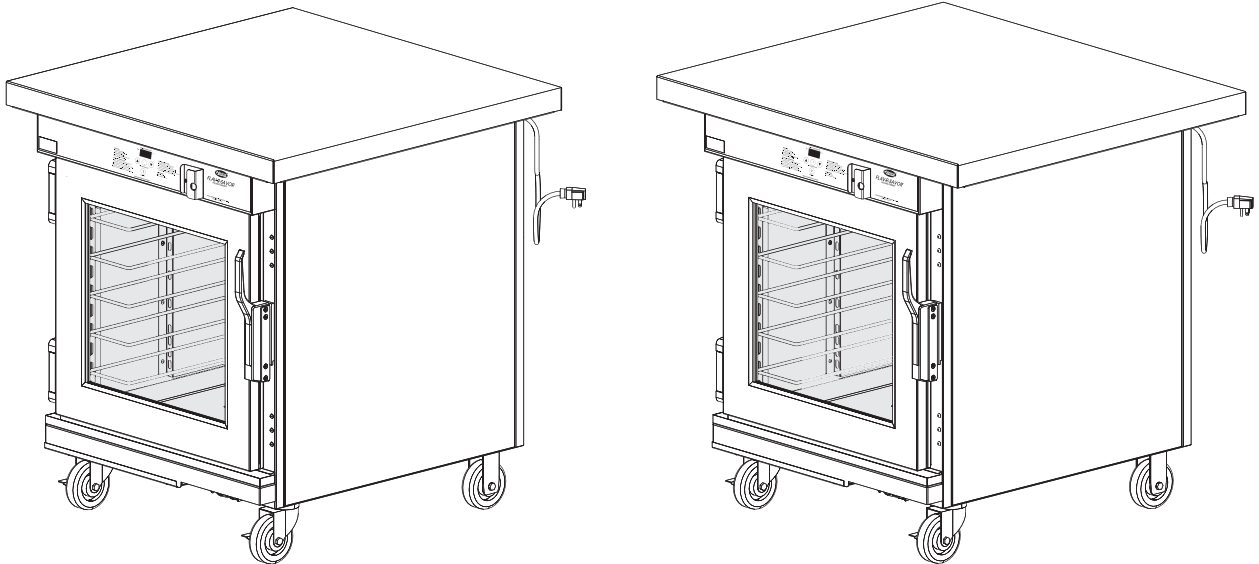

⚠ WARNING

Do not operate this equipment unless you have read and understood the contents of this manual! Failure to follow the instructions contained in this manual may result in serious injury or death. This manual contains important safety information concerning the maintenance, use, and operation of this product. If you're unable to understand the contents of this manual, please bring it to the attention of your supervisor. Keep this manual in a safe location for future reference.

⚠ ADVERTENCIA

No opere este equipo al menos que haya leído y comprendido el contenido de este manual! Cualquier falla en el seguimiento de las instrucciones contenidas en este manual puede resultar en un serio lesión o muerte. Este manual contiene importante información sobre seguridad concerniente al mantenimiento, uso y operación de este producto. Si usted no puede entender el contenido de este manual por favor pregunte a su supervisor. Almacenar este manual en una localización segura para la referencia futura.

⚠ AVERTISSEMENT

Ne pas utiliser cet équipement sans avoir lu et compris le contenu de ce manuel ! Le non-respect des instructions contenues dans ce manuel peut entraîner de graves blessures ou la mort. Ce manuel contient des informations importantes concernant l'entretien, l'utilisation et le fonctionnement de ce produit. Si vous ne comprenez pas le contenu de ce manuel, veuillez le signaler à votre supérieur. Conservez ce manuel dans un endroit sûr pour pouvoir vous y référer plus tard.

CONTENTS

Important Owner Information	2	Operation	8
Introduction	2	General	8
Important Safety Information	3	Setting the Air Temperature	9
Model Description	4	Setting the Humidity Level	9
Model Designation	4	Food Holding Guide	9
Specifications	5	Maintenance	10
Plug Configuration	5	General	10
Electrical Rating Chart	5	Daily Cleaning	10
Dimensions	5	Removing Lime and Mineral Deposits	11
Installation	6	Troubleshooting Guide	12
General	6	Error Codes	12
Adjusting the Top Shelf	7	Limited Warranty	13
Reversing the Access Door	7	Replacement Parts List	14
		Authorized Parts Distributors	Back Cover

IMPORTANT OWNER INFORMATION

Record the model number, serial number, voltage, and purchase date of the unit in the spaces below (specification label located on the back of the unit). Please have this information available when calling Hatco for service assistance.

Model No. _____

Serial No. _____

Voltage _____

Date of Purchase _____

Register your unit!

Completing online warranty registration will prevent delay in obtaining warranty coverage. Access the Hatco website at www.hatcocorp.com, select the *Parts & Service* pull-down menu, and click on "Warranty Registration".

Business Hours: 7:00 AM to 5:00 PM Central Standard Time (CST)

(Summer Hours: June to September—
7:00 AM to 5:00 PM CST Monday–Thursday
7:00 AM to 4:00 PM CST Friday)

Telephone: 800-558-0607; 414-671-6350

E-mail: partsandservice@hatcocorp.com

Fax: 800-690-2966 (Parts and Service)
414-671-3976 (International)



24 Hour 7 Day Parts and Service Assistance available in the United States and Canada by calling 800-558-0607.

Additional information can be found by visiting our web site at www.hatcocorp.com.

INTRODUCTION

Hatco Flav-R-Savor® Portable Holding Cabinets are designed to hold prepared foods for prolonged periods of time while maintaining that "just-made" quality. They provide the best environment for food products by regulating the air temperature while at the same time balancing the humidity level. The use of controlled, moisturized heat maintains serving temperature and food texture longer than conventional dry holding equipment.

The Flav-R-Savor air flow pattern is designed to maintain consistent cabinet temperature without drying out foods. The precise combination of heat and humidity creates a "blanket" effect around the food. The air flow rate enables the cabinet to rapidly recover temperature after opening and closing the door.

Flav-R-Savor Portable Holding Cabinets are products of extensive research and field testing. The materials used were selected for maximum durability, attractive appearance, and optimum performance. Every unit is inspected and tested thoroughly prior to shipment.

This manual provides the installation, safety, and operating instructions for a Flav-R-Savor Portable Holding Cabinet. Hatco recommends all installation, operating, and safety instructions appearing in this manual be read prior to installation or operation of the unit.

Safety information that appears in this manual is identified by the following signal word panels:



WARNING indicates a hazardous situation which, if not avoided, could result in death or serious injury.



CAUTION indicates a hazardous situation which, if not avoided, could result in minor or moderate injury.

NOTICE

NOTICE is used to address practices not related to personal injury.

IMPORTANT SAFETY INFORMATION



Read the following important safety information before using this equipment to avoid serious injury or death and to avoid damage to equipment or property.

⚠ WARNING

ELECTRIC SHOCK HAZARD:

- Plug unit into a properly grounded electrical receptacle of the correct voltage, size, and plug configuration. If plug and receptacle do not match, contact a qualified electrician to determine and install proper voltage and size electrical receptacle.
- Turn OFF power switch, unplug power cord, and allow unit to cool before performing any cleaning, adjustments, or maintenance.
- DO NOT submerge or saturate with water. Unit is not waterproof. Do not operate if unit has been submerged or saturated with water.
- Unit is not weatherproof. Locate unit indoors where ambient air temperature is a minimum of 70°F (21°C).
- This unit is not “jet-proof” construction. Do not use jet-clean spray to clean this unit.
- Do not steam clean or use excessive water on unit.
- Turn power switch OFF and allow unit to cool before draining water reservoir.
- Do not pull unit by power cord.
- Discontinue use if power cord is frayed or worn.
- Do not attempt to repair or replace a damaged power cord. Cord must be replaced by Hatco, an Authorized Hatco Service Agent, or a person with similar qualifications.
- This unit must be serviced by qualified personnel only. Service by unqualified personnel may lead to electric shock or burn.
- Use only Genuine Hatco Replacement Parts when service is required. Failure to use Genuine Hatco Replacement Parts will void all warranties and may subject operators of the equipment to hazardous electrical voltage, resulting in electrical shock or burn. Genuine Hatco Replacement Parts are specified to operate safely in the environments in which they are used. Some aftermarket or generic replacement parts do not have the characteristics that will allow them to operate safely in Hatco equipment.

FIRE HAZARD: Locate unit a minimum of 1” (25 mm) from combustible walls and materials. If safe distances are not maintained, combustion or discoloration could occur.

Make sure food product has been heated to the proper food-safe temperature before placing in unit. Failure to heat food product properly may result in serious health risks. This unit is for holding pre-heated food product only.

Hatco Corporation is not responsible for actual food product serving temperature. It is the responsibility of the user to ensure that food product is held and served at a safe temperature.

⚠ WARNING

Make sure all operators have been instructed on the safe and proper use of the unit.

This unit is not intended for use by children or persons with reduced physical, sensory, or mental capabilities. Ensure proper supervision of children and keep them away from the unit.

This unit has no “user-serviceable” parts. If service is required on this unit, contact an Authorized Hatco Service Agent or contact the Hatco Service Department at 800-558-0607 or 414-671-6350; fax 800-690-2966; or International fax 414-671-3976.

⚠ CAUTION

BURN HAZARD:

- Some exterior surfaces on unit will get hot. Use caution when touching these areas.
- Turn off unit and allow it to cool before draining water from water reservoir.

Locate unit in an area that is convenient for use. The location should be level to prevent unit or its contents from falling accidentally and strong enough to support the weight of the unit and contents.

Do not overfill water reservoir. Overfilling can cause water to leak onto floor and create a slipping hazard.

Transport unit in upright position only. Make sure all water is drained prior to transport.

NOTICE

Do not lay unit on side with control panel or damage to unit could occur. Make sure all water is drained prior to laying unit on its side.

Use non-abrasive cleaners and cloths only. Abrasive cleaners and cloths could scratch finish of unit, marring its appearance and making it susceptible to soil accumulation.

Use of distilled water in water reservoir of humidified units is recommended. If non-distilled water is used, reservoir will require periodic cleaning and deliming (refer to MAINTENANCE section for cleaning procedure). Product failure caused by liming or sediment buildup is not covered under warranty.

Clean unit daily to avoid malfunctions and maintain sanitary operation.

MODEL DESCRIPTION

The Flav-R-Savor® Portable Holding Cabinet is constructed of sturdy stainless steel. It features electronically-controlled heat, low velocity convected air, a humidity system, and a heavy-duty, insulated, glass access door. The access door can be hinged left or right, depending on the application. The digital temperature controller is easily accessible. The POWER ON/OFF (I/O) switch features a safety cover. The unit is made portable by using 4" (102 mm) casters—the front two being swivel casters with wheel locks. Units come standard in *Designer* black, are available in optional stainless steel. An attached 6' (1829 mm) power cord and plug is standard.

The interior of the cabinet is equipped with five pairs of adjustable, stainless steel pan slides. These pan slides are designed to hold full size sheet pans, several steam table pan sizes (full, half, and third), and Gastronorm pans.

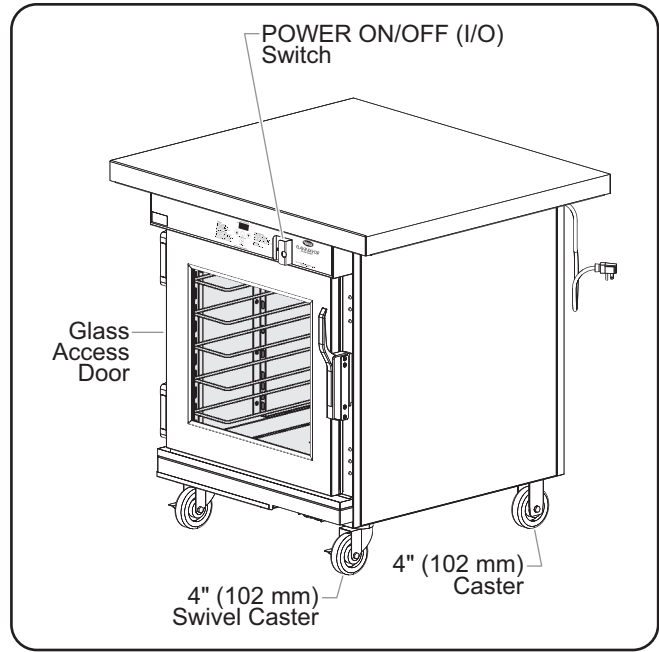

Flav-R-Savor Portable Holding Cabinet (36" [914 mm] Top)

MODEL DESIGNATION

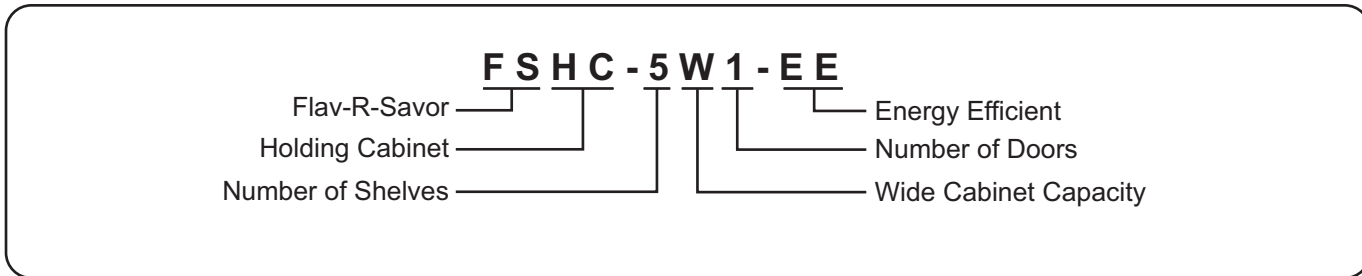

SPECIFICATIONS

Plug Configuration

Units are supplied from the factory with an electrical cord and plug installed.



ELECTRIC SHOCK HAZARD: Plug unit into a properly grounded electrical receptacle of the correct voltage, size, and plug configuration. If the plug and receptacle do not match, contact a qualified electrician to determine and install the proper voltage and size electrical receptacle.

NOTE: The specification label is located on the back of the unit. See label for serial number and verification of unit electrical information.

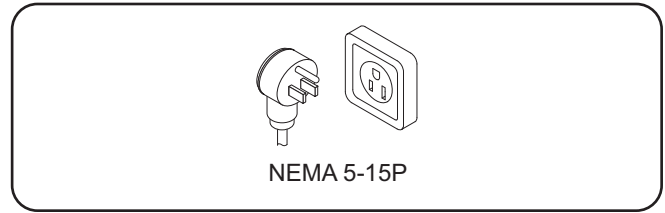

NEMA 5-15P

Plug Configuration

NOTE: Receptacle not supplied by Hatco.

Electrical Rating Chart

Model	Humidified	Voltage	Watts	Amps	Hertz	Plug Configuration	Shipping Weight
FSHC-5W1-EE	Yes	120	1118	9.3	60	NEMA 5-15P	250 lbs. (113 kg)

Dimensions

Model	Width (A)*	Depth (B)	Height (C)
FSHC-5W1-EE	36" (914 mm)	32-3/8" (821 mm)	36" (914 mm)
Interior Capacity: 20-15/16" W x 26-5/8" D x 18-3/16" H (532 x 676 x 462 mm)			

* Also available in 26" (661 mm) and 32" (813 mm) width.

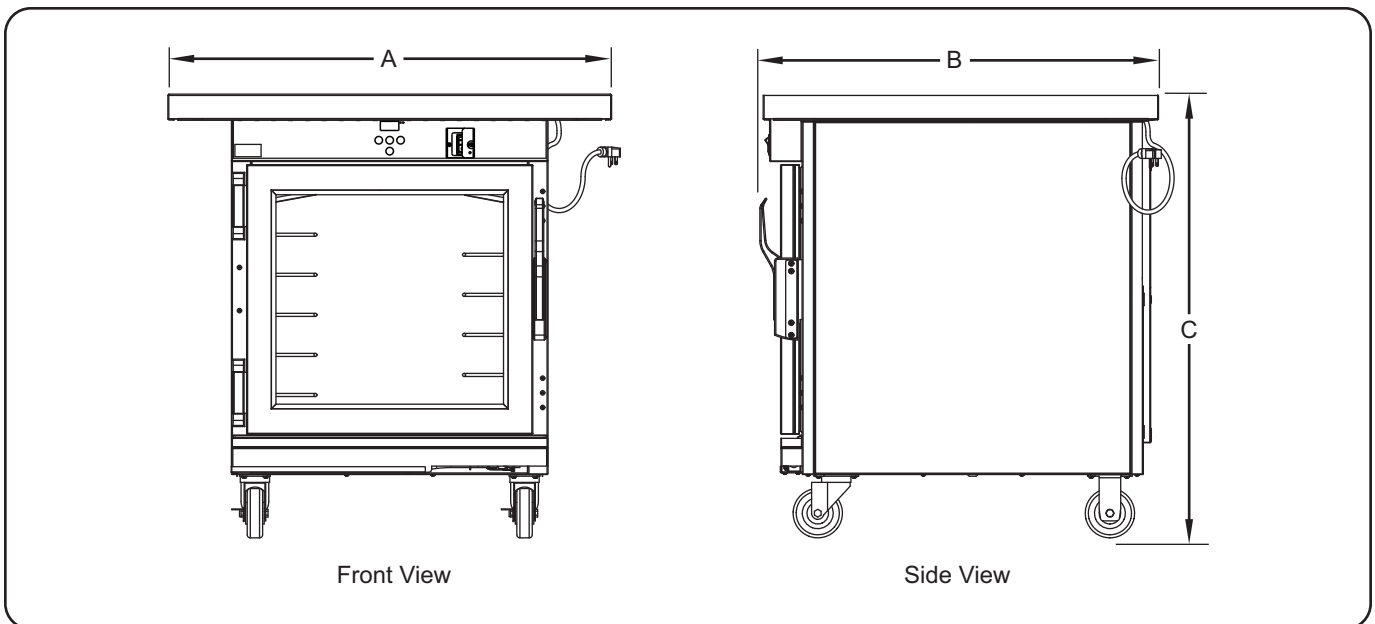

INSTALLATION

General

The Flav-R-Savor Portable Holding Cabinet is shipped with most components installed and ready for operation. The following installation instructions must be performed before plugging in and operating the cabinet.

⚠ WARNING

ELECTRIC SHOCK HAZARD: Unit is not weatherproof. Locate the unit indoors where the ambient air temperature is a minimum of 70°F (21°C).

FIRE HAZARD: Locate unit a minimum of 1" (25 mm) from combustible walls and materials. If safe distances are not maintained, combustion or discoloration could occur.

⚠ CAUTION

Locate unit in an area that is convenient for use. The location should be level to prevent unit or its contents from falling accidentally and strong enough to support the weight of the unit and contents.

1. Remove the unit from the carton.
2. Remove all loose items shipped inside the cabinet such as the box containing the adjustable pan slides, the casters, etc...

NOTE: To prevent delay in obtaining warranty coverage, complete online warranty registration. See the IMPORTANT OWNER INFORMATION section for details.

3. Remove tape and protective packaging from all surfaces of the unit.

4. Install the 4" (102 mm) casters onto the bottom of the cabinet.

NOTICE

Do not lay unit on side with control panel or damage to unit could occur. Make sure all water is drained prior to laying unit on its side.

- a. Carefully lay the unit on its back side. This step requires two people.

NOTE: Place a piece of cardboard between the cabinet and the floor to prevent marring the cabinet finish.

- b. Install the two swivel casters to the front of the unit using mounting screws (provided). Tighten securely.
- c. Install the two stationary casters to the back of the unit using mounting screws (provided). Tighten securely.
- d. Return the unit to its upright position. This step requires two people.

5. Unpack the adjustable pan slides from the box and install them inside the cabinet. There are ten adjustable pan slides—five on each side of the cabinet. Four shelf supports, two on each side of the cabinet, support the pan slides.

To install each pan slide:

- a. Align the hooks at each end of the pan slide with the desired slots on the front and rear shelf supports.
- b. Angle the pan slide hooks into the slots and let the pan slide rotate down into position.

6. Place the reservoir cover over the built-in water reservoir.

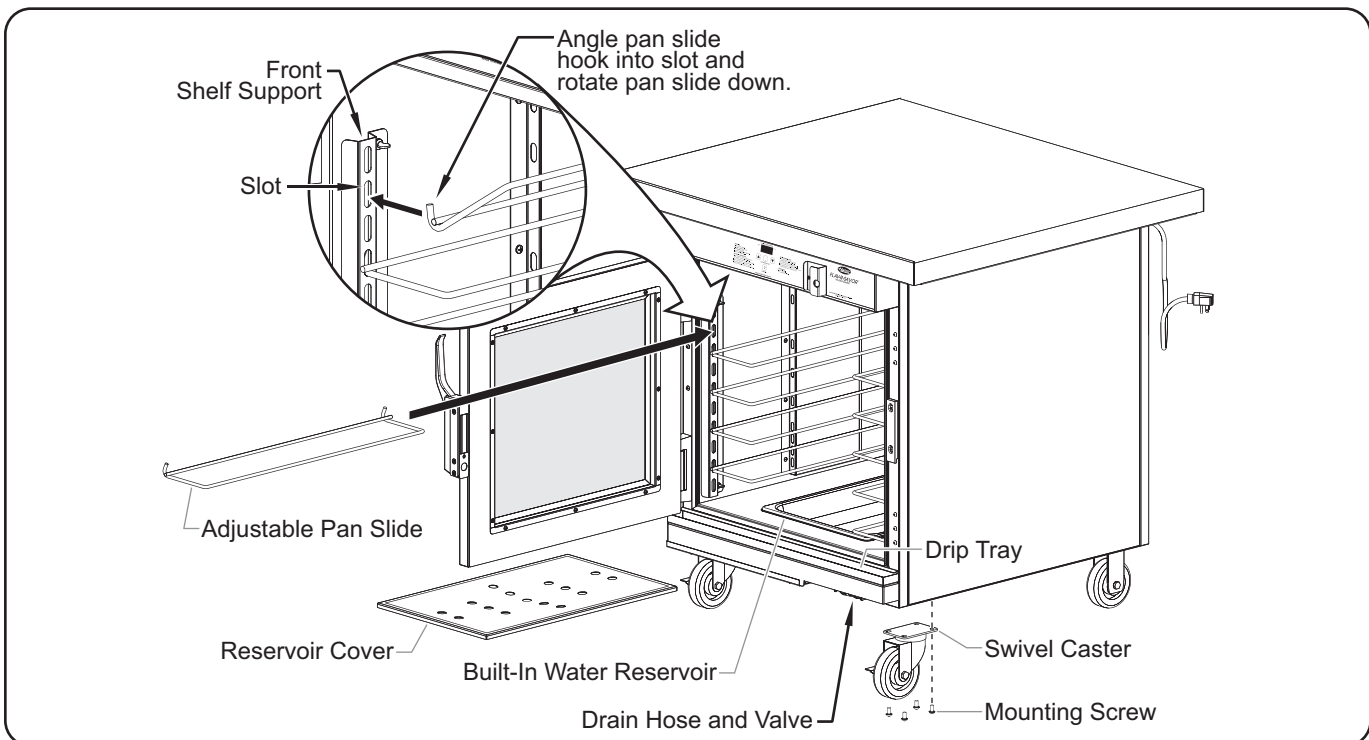

Installing the Components

7. Place the unit in the desired location.
 - Locate the unit in an area where the ambient air temperature is constant and a minimum of 70°F (21°C). Avoid areas that may be subject to active air movements or currents (i.e., near exhaust fans/hoods and air conditioning ducts).
 - Make sure the unit is located on solid, level flooring.
 - Make sure the unit is at the proper height in an area convenient for use.

Adjusting the Top Shelf (Side to Side)

The top shelf of the unit can be adjusted from side to side in 1" (25 mm) increments. Use the following procedure to adjust the top shelf.

1. Remove the two screws holding the top shelf in place.
2. Move the top shelf to either side until it is in the desired location.
3. Make sure the screw holes on the top shelf align with the screw holes on the unit. Install the screws into place. Tighten securely.

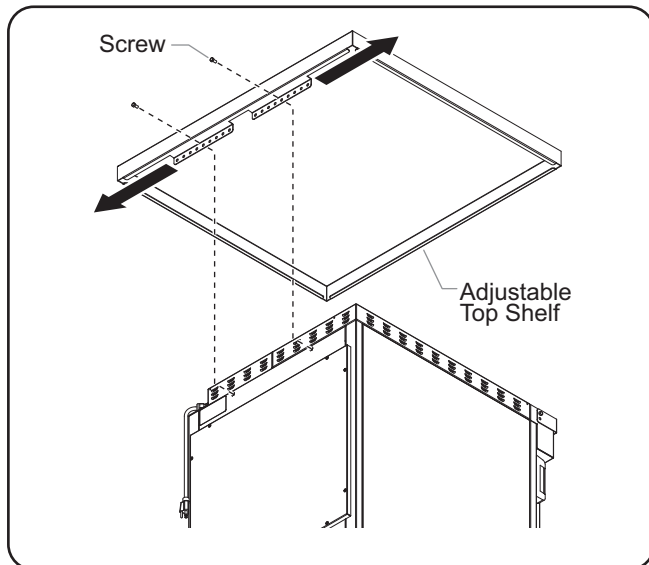

Adjusting the Top Shelf

Reversing the Access Door

The access door is field reversible to allow it to be hinged on either the right or left side. Use the following procedure to reverse the door.

1. Remove the four handle screws securing the handle to the door. Remove the handle.
2. Slide the hinge covers off of the door hinges.
3. At each door hinge, remove the three hinge screws that secure the hinges to the cabinet frame. Remove the access door.

NOTE: The hinges remain mounted to the access door.

4. Transfer the screw plugs from the hinge screw holes on the opposite side of the cabinet to the open holes where the hinges were just removed.

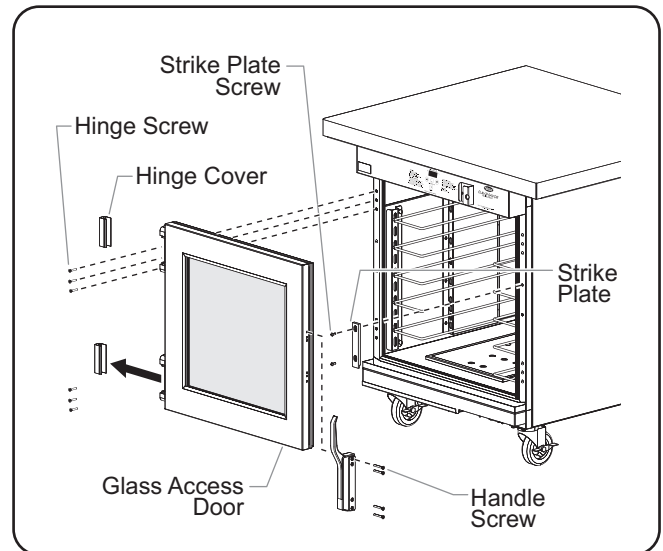

Removing the Access Door

5. Remove the two strike plate screws that secure the strike plate to the cabinet.
6. Transfer the screw plugs from the strike plate holes on the opposite side of the cabinet to the open holes where the strike plate was just removed.
7. Install the strike plate on the opposite side of the cabinet using the original hardware.
8. Rotate the door 180° and install on the opposite side of cabinet using the original hardware.
9. Install the handle to the door in the upright position using the original hardware.
10. Slide the hinge covers back into place on the door hinges.

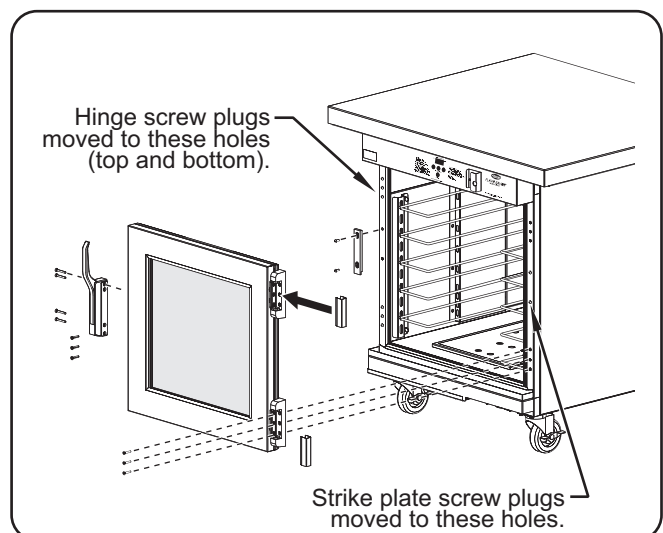

Reversing and Installing the Access Door

OPERATION

General

Use the following procedures to operate a Flav-R-Savor® Portable Holding Cabinet.



WARNING

Read all safety messages in the **IMPORTANT SAFETY INFORMATION** section before operating this equipment.

Startup

1. Plug the unit into a properly grounded electrical receptacle of the correct voltage, size, and plug configuration. See the SPECIFICATIONS section for details.



NOTICE

Use of distilled water in water reservoir of humidified units is recommended. If non-distilled water is used, reservoir will require periodic cleaning and deliming (refer to MAINTENANCE section for cleaning procedure). Product failure caused by liming or sediment buildup is not covered under warranty.

2. Fill the built-in water reservoir with distilled water. To fill the water reservoir:
 - a. Open the access door.
 - b. Remove the reservoir cover.
 - c. Slowly pour water into the water reservoir until the water level reaches the fill line on the back of the reservoir. Do not fill water above this line.
 - d. Replace the reservoir cover.
 - e. Close the access door.

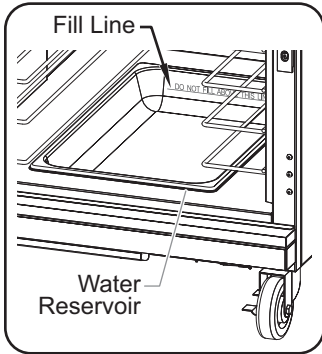

NOTE: Clean the water reservoir daily to extend the life of the electrical and mechanical components and to keep cleaning easy. If “hard” water is used, the reservoir will require periodic cleaning and de-liming. Refer to the MAINTENANCE section for de-liming instructions.



CAUTION

Do not overfill water pan. Overfilling can cause water to leak onto floor and create a slipping hazard.

NOTE: The capacity of the water reservoir is approximately four (4) quarts (3.8 liters).

3. Move the POWER ON/OFF (I/O) switch to the ON (I) position.
 - The heating system will start up.
 - The CABINET TEMPERATURE display will show the current temperature of the cabinet or “LO”. “LO” indicates the cabinet temperature is below 70°F (21°C).



CAUTION

BURN HAZARD: Some exterior surfaces on the unit will get hot. Use caution when touching these areas.

4. Set the air temperature to 180°F (82°C). Refer to the “Setting the Air Temperature” procedure in this section for more information.

5. Set the humidity to level 1. Refer to the “Setting the Humidity Level” procedure in this section for more information.

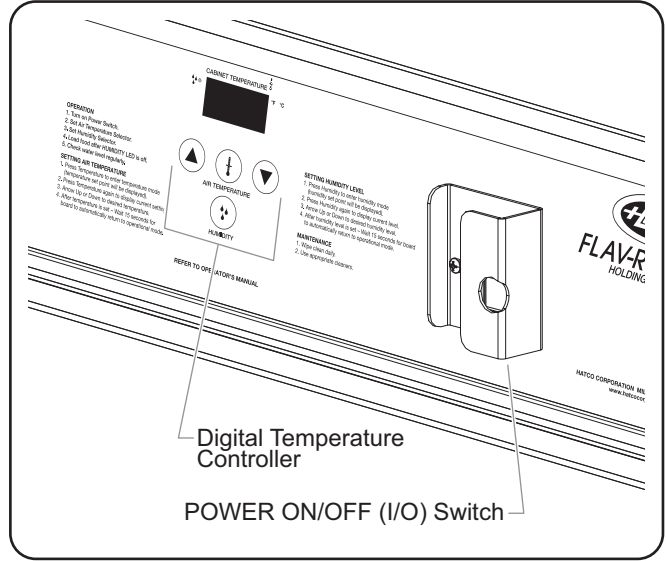

Controls

6. Allow 30 minutes to preheat the cabinet with a full pan of water before loading preheated food product. The unit is ready when the CABINET TEMPERATURE display shows 180°F (82°C) as the temperature.
7. Place a sheet pan and wire rack OR a full size 2" deep stainless steel pan with a wire rack on the center shelf.
 - Place additional pans and racks on the racks starting from the top and moving to the bottom. No more than three pans should be used in the cabinet at a time.
8. Place cooked and drained chicken on the wire rack bone side down.
 - Chicken may be held for up to 3 hours and must maintain an internal temperature of 165°F (74°C).
9. If chicken is not sold within 3 hours, place chicken in an individual container with label and date (do not cover until cool). Store in refrigerator.
 - Do not store warm chicken with cooled chicken.
 - Use chicken within 48 hours or discard.
10. If refrigerated chicken is unused within 48 hours, place chicken in freezer until needed. This requires a 24 hour thaw time.



WARNING





Make sure food product has been heated to the proper food-safe temperature before placing in unit. Failure to heat food product properly may result in serious health risks. This unit is for holding pre-heated food product only.

Shutdown

1. Move the POWER ON/OFF (I/O) Switch to the OFF (O) position and allow the unit to cool.
2. Perform the “Daily Cleaning” procedure in the MAINTENANCE section of this manual.

Setting the Air Temperature

Use the following procedure to set or change the air temperature.

1. Press the  key to enter temperature mode ("tSP" will appear on the CABINET TEMPERATURE display).
2. Press the  key again to show the current temperature setting.
3. Press the  key or  key to reach the desired temperature. The temperature range is 80°–200°F (27°–93°C) in single degree increments. Culver's recommends 180°F (82°C) for this unit.
4. After the desired temperature is set, wait 15 seconds without pushing any keys for the cabinet temperature display to return automatically to operational mode.

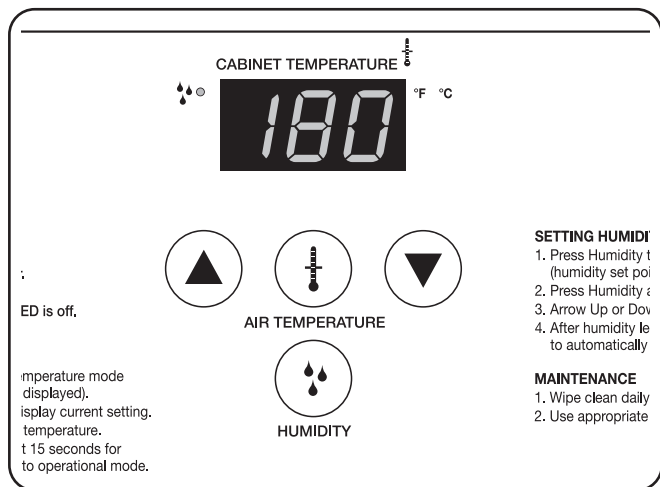

Setting the Air Temperature

NOTE: Temperature and humidity settings may vary depending upon product make-up and consistency. The CABINET TEMPERATURE display shows the lowest temperature point inside the cabinet, not the product temperature.





Food Holding Guide

Type of Food	Maximum Holding Time	Humidity Setting	Air Temperature Setting	
			°F	°C
Biscuits	4 Hours	3	140	60
Chicken Pieces (Fried)	4 Hours	1	170	77
Croissants	4 Hours	1	140	60
Fruit Pies	3-1/2 Hours	3	140	60
Onion Rings	1/2 to 2 Hours	1	180	82
Pizza — Thick Crust	1 Hour	1	185	85
Thin Crust	1 Hour	2	180	82
Pretzels	3 Hours	3	140	60
Wrapped Sandwiches	2 Hours	3	170	77

NOTE: All times and settings are recommendations only and may vary depending on product preparation, cooking time, and internal food temperature.

Setting the Humidity Level

Use the following procedure to set the humidity level on humidified units.

1. Press the  key to enter humidity mode ("hSP" will appear on the CABINET TEMPERATURE display).
2. Press the  key again to show the current humidity level.
3. Press the  key or  key to reach the desired humidity level. Humidity range is 0 through 5 (0 is the lowest amount of humidity and 5 is the highest). Culver's recommends humidity level 1 for this unit.

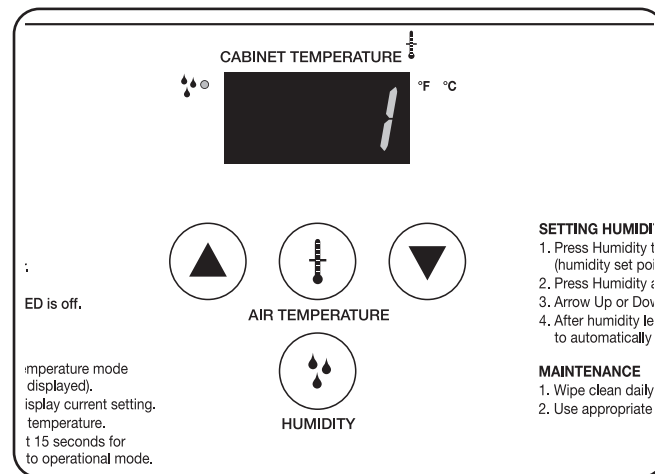

Setting the Humidity Level

4. After the desired humidity level is set, wait 15 seconds without pushing any keys for the cabinet temperature display to return automatically to operational mode.

The capacity of the water reservoir permits uninterrupted operation for approximately 7–9 hours, depending on the settings and how frequently the door is opened. Check the water level in the reservoir regularly, and re-fill when necessary. The water reservoir refill capacity is approximately four (4) quarts (3.8 liters). **WARNING! Electric Shock Hazard — Do not overfill water reservoir.**

MAINTENANCE

General

The Flav-R-Savor Portable Holding Cabinet is designed for maximum durability and performance with minimum maintenance.

⚠ WARNING

ELECTRIC SHOCK HAZARD:

- Turn OFF power switch, unplug power cord, and allow unit to cool before performing any cleaning, adjustments, or maintenance.
- DO NOT submerge or saturate with water. Unit is not waterproof. Do not operate if unit has been submerged or saturated with water.
- Unit is not weatherproof. Locate unit indoors where ambient air temperature is a minimum of 70°F (21°C).
- This unit is not “jet-proof” construction. Do not use jet-clean spray to clean this unit.
- Do not steam clean or use excessive water on unit.
- Do not clean unit when it is energized or hot.
- This unit must be serviced by qualified personnel only. Service by unqualified personnel may lead to electric shock or burn.

This unit has no “user-serviceable” parts. If service is required on this unit, contact an Authorized Hatco Service Agent or contact the Hatco Service Department at 800-558-0607 or 414-671-6350; fax 800-690-2966; or International fax 414-671-3976.

NOTE: The internal blower motor is permanently lubricated and requires no maintenance.

Daily Cleaning

To preserve the finish of the unit as well as maintain performance, it is recommended that the unit be cleaned daily.

⚠ WARNING

ELECTRIC SHOCK HAZARD: Turn OFF power switch, unplug power cord, and allow unit to cool before performing any cleaning, adjustments, or maintenance.

NOTICE

Use non-abrasive cleaners and cloths only. Abrasive cleaners and cloths could scratch finish of unit, marring its appearance and making it susceptible to soil accumulation.

Clean unit daily to avoid malfunctions and maintain sanitary operation.

1. Move the POWER ON/OFF (I/O) switch to the OFF (O) position, unplug power cord, and allow the unit to cool.
2. Remove and wash all food pans.
3. Locate the drain hose with hose valve near the bottom, right side of the cabinet underneath the drip tray.
CAUTION! Burn Hazard—Water in reservoir is hot during operation. Allow to cool before draining.
4. Position a 2-1/2" (64 mm) deep, full size food pan under the drain stopper to catch draining water.
5. Unlatch the hose valve to open the drain hose and empty the reservoir.

6. Flush the water reservoir with fresh water.
7. Wipe the interior of the water reservoir until it is dry with a clean, non-abrasive cloth.
8. Squeeze the hose valve to close the drain hose.

NOTE: If the water used has an excessive amount of lime or mineral content, follow the “Removing Lime and Mineral Deposits” procedure for periodic cleaning and deliming of the water reservoir. Unit failure caused by liming or sediment buildup is not covered under warranty.

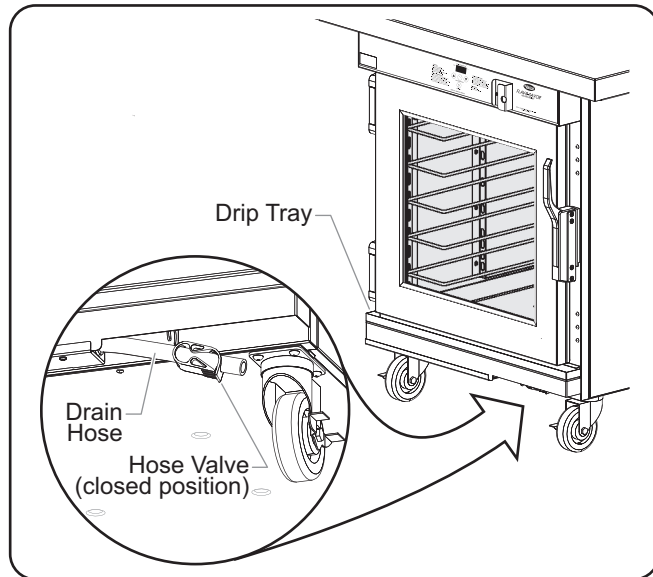

Draining the Water Reservoir

9. Wipe down all the interior and the exterior surfaces using a clean, damp cloth. Stubborn stains may be removed with a good non-abrasive cleaner. Hard to reach areas should be cleaned with a small brush and mild soap.
10. Wipe dry with a clean, non-abrasive cloth.

Removing Lime and Mineral Deposits

Use the following procedure for periodic cleaning and deliming of the water reservoir on humidified models.

NOTICE

Use of distilled water in water reservoir of humidified units is recommended. If non-distilled water is used, reservoir will require periodic cleaning and deliming. Product failure caused by liming or sediment buildup is not covered under warranty.

NOTE: The lime and mineral content of the water used for daily operation will determine how often the deliming procedure must be performed.

NOTE: Perform this procedure when the unit will not be used for a period of time, such as the end of the day. (Recommended monthly)

1. Move the POWER ON/OFF (I/O) switch to the OFF (O) position. Allow the unit to cool.
2. Remove and wash all food pans.
3. Remove the reservoir cover.
4. Fill the water reservoir with a mixture of 75% water and 25% white vinegar. Do not use flavored vinegar.
5. Replace the reservoir cover.
6. Turn on the unit.
7. Set both the air temperature and humidity level to their highest settings and allow the unit to run for 30 minutes.
8. Move the POWER ON/OFF (I/O) switch to the OFF (O) position, unplug power cord, and allow the unit to cool.
9. Drain the vinegar mixture and rinse reservoir thoroughly.
10. Continue to fill and drain the water reservoir with clean water until the deliming solution is rinsed through and the reservoir is clean.
11. After the unit has cooled down, perform the "Daily Cleaning" procedure in this section.
12. Plug the unit into its power source and fill the reservoir as usual for daily operation. Refer to the procedure in the OPERATION section of this manual.

TROUBLESHOOTING GUIDE



This unit must be serviced by trained and qualified personnel only. Service by unqualified personnel may lead to electric shock or burn.



ELECTRIC SHOCK HAZARD: Turn OFF power switch, unplug power cord, and allow unit to cool before performing any cleaning, adjustments, or maintenance.

Symptom	Probable Cause	Corrective Action
Unit is plugged in, but nothing works.	Unit not turned on.	Move POWER ON/OFF (I/O) switch to the ON (I) position.
	No power to unit.	Check electrical receptacle and verify that power supply matches specifications on unit. If receptacle is not working, check circuit breaker and reset, or plug unit into a different known working receptacle.
	Power cord connections are loose or disconnected.	Contact Authorized Service Agent or Hatco for assistance.
	Power cord is damaged.	Contact Authorized Service Agent or Hatco for assistance.
	Defective POWER ON/OFF (I/O) switch.	Contact Authorized Service Agent or Hatco for assistance.
	Defective digital temperature controller.	Contact Authorized Service Agent or Hatco for assistance.
Unit operates, but is not circulating air inside cabinet.	Blower motor defective.	Contact Authorized Service Agent or Hatco for assistance.
	Incorrect voltage supplied to blower motor.	Contact Authorized Service Agent or Hatco for assistance.
Unit is leaking.	The hose valve is not tight enough.	Tighten drain hose by squeezing the hose valve.
Unit is not producing any "hot air" inside cabinet.	Safety high-limit is tripped or open.	Contact Authorized Service Agent or Hatco for assistance.
	Incorrect voltage supplied to heating element.	Contact Authorized Service Agent or Hatco for assistance.
	Blower motor not working.	Contact Authorized Service Agent or Hatco for assistance.
	Air heating element(s) defective.	Contact Authorized Service Agent or Hatco for assistance.
Unit is heating, but is not producing humidity inside cabinet.	Water reservoir is empty.	Fill water reservoir with clean water.
	Humidity is set too low.	Increase humidity level. Refer to "Setting the Humidity Level" in the OPERATION section.
	Incorrect voltage supplied to water heating element or heating element defective.	Contact Authorized Service Agent or Hatco for assistance.

Error Codes

The following error codes may appear on the CABINET TEMPERATURE display to indicate an error in the operating condition of the unit.

E1 = Air temperature sensor malfunctioning. Contact Authorized Service Agent or Hatco for assistance.

E2 = Humidity sensor malfunctioning. Contact Authorized Service Agent or Hatco for assistance.

Troubleshooting Questions?

If you continue to have problems resolving an issue, please contact the nearest Authorized Hatco Service Agency or Hatco for assistance. To locate the nearest Service Agency, log onto the Hatco website at www.hatcocorp.com and click on *Find Service Agent*, or contact the **Hatco Parts and Service Team** at:

Telephone: 800-558-0607 or 414-671-6350

e-mail: partsandservice@hatcocorp.com

Fax: 800-690-2966 or 414-671-3976



1. PRODUCT WARRANTY

Hatco warrants the products that it manufactures (the "Products") to be free from defects in materials and workmanship, under normal use and service, for a period of one (1) year from the date of purchase when installed and maintained in accordance with Hatco's written instructions or 18 months from the date of shipment from Hatco. Buyer must establish the Product's purchase date by registering the Product with Hatco or by other means satisfactory to Hatco in its sole discretion.

Hatco warrants the following Product components to be free from defects in materials and workmanship from the date of purchase (subject to the foregoing conditions) for the period(s) of time and on the conditions listed below:

- a) **One (1) Year Parts and Labor PLUS One (1) Additional Year Parts-Only Warranty:**
 - Conveyor Toaster Elements (metal sheathed)
 - Drawer Warmer Elements (metal sheathed)
 - Drawer Warmer Drawer Rollers and Slides
 - Strip Heater Elements (metal sheathed)
 - Display Warmer Elements (metal sheathed air heating)
 - Holding Cabinet Elements (metal sheathed air heating)
 - Heated Well Elements — HW and HWB Series (metal sheathed)

- b) **One (1) Year Parts and Labor PLUS Four (4) Years Parts-Only Warranty:**
 - 3CS and FR Tanks

- c) **One (1) Year Parts and Labor PLUS Nine (9) Years Parts-Only Warranty on:**
 - Electric Booster Heater Tanks
 - Gas Booster Heater Tanks

- d) **Ninety (90) Day Parts-Only Warranty:**
 - Replacement Parts

THE FOREGOING WARRANTIES ARE EXCLUSIVE AND IN LIEU OF ANY OTHER WARRANTY, EXPRESSED OR IMPLIED, INCLUDING BUT NOT LIMITED TO ANY IMPLIED WARRANTY OF MERCHANTABILITY OR FITNESS FOR A PARTICULAR PURPOSE OR PATENT OR OTHER INTELLECTUAL PROPERTY RIGHT INFRINGEMENT. Without limiting the generality of the foregoing, SUCH WARRANTIES DO NOT COVER: Coated incandescent light bulbs, fluorescent lights, heat lamp bulbs, coated halogen light bulbs, halogen heat lamp bulbs, xenon light bulbs, LED light tubes, glass components, and fuses; Product failure in booster tank, fin tube heat exchanger, or other water heating equipment caused by liming, sediment buildup, chemical attack, or freezing; or Product misuse, tampering or misapplication, improper installation, or application of improper voltage.

2. LIMITATION OF REMEDIES AND DAMAGES

Hatco's liability and Buyer's exclusive remedy hereunder will be limited solely, at Hatco's option, to repair or replacement using new or refurbished parts or Product by Hatco or a Hatco-authorized service agency (other than where Buyer is located outside of the United States, Canada, United Kingdom, or Australia, in which case Hatco's liability and Buyer's exclusive remedy hereunder will be limited solely to replacement of part under warranty) with respect to any claim made within the applicable warranty period referred to above. Hatco reserves the right to accept or reject any such claim in whole or in part. In the context of this Limited Warranty, "refurbished" means a part or Product that has been returned to its original specifications by Hatco or a Hatco-authorized service agency. Hatco will not accept the return of any Product without prior written approval from Hatco, and all such approved returns shall be made at Buyer's sole expense. HATCO WILL NOT BE LIABLE, UNDER ANY CIRCUMSTANCES, FOR CONSEQUENTIAL OR INCIDENTAL DAMAGES, INCLUDING BUT NOT LIMITED TO LABOR COSTS OR LOST PROFITS RESULTING FROM THE USE OF OR INABILITY TO USE THE PRODUCTS OR FROM THE PRODUCTS BEING INCORPORATED IN OR BECOMING A COMPONENT OF ANY OTHER PRODUCT OR GOODS.

REPLACEMENT PARTS LIST

Hatco Flav-R-Savor® Portable Holding Cabinet FSHC-5W Series

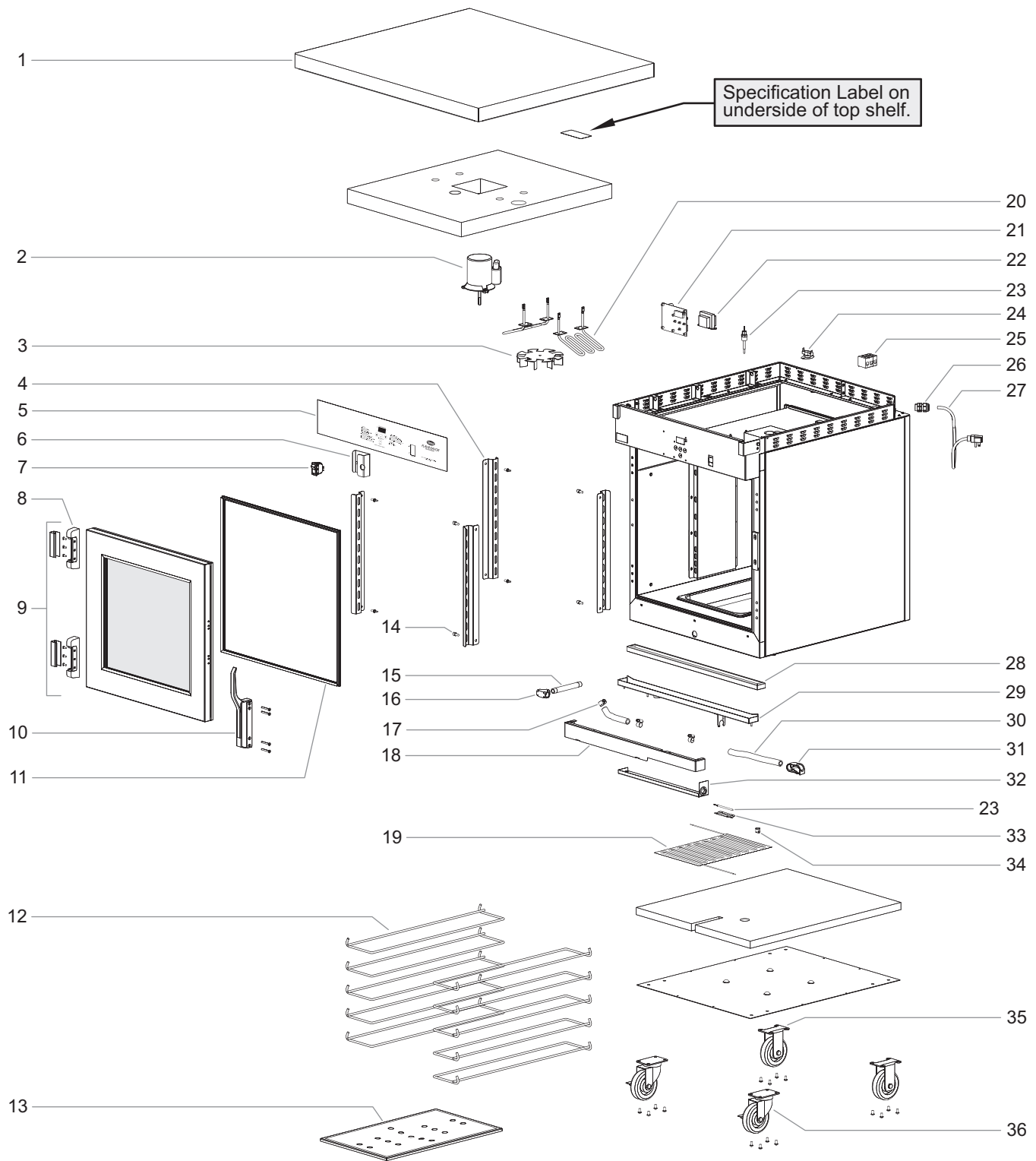

REPLACEMENT PARTS LIST

Item	Description	Part No.	Qty.
1	Top		
	36" Countertop	04.48.782.00	1
	32" Countertop	04.48.785.00	1
	25-3/4" Top	04.48.876.01	1
2	Blower Motor and Blower Blade	R02.12.117.00	1
3	Blower Blade	02.12.065.00	1
4	Shelf Support Frame	04.48.772.00	4
5	Control Panel Label	07.01.370.00	1
6	Switch Guard, Rocker	04.48.975.00	1
7	Switch, Rocker	02.19.015.00	1
8	Hinge	04.26.002.00	2
9	Door Assembly †	R00.01.0141.00	1
10	Handle	05.30.113.00	1
11	Door Gasket	05.06.147.00	1
12	Pan Slide	04.48.364.00	10
13	Cover, Reservoir	04.48.919.00	1
14	Thumbscrew	05.04.708.00	8
15	Pipe Nipple, 3/8"	03.11.003.00	1
16	Tee, 3/8"	03.05.122.00	1
17	Hose Clamp, 1/2"	05.04.550.00	3
18	Drip Tray Skirt	04.48.748.00	1

Item	Description	Part No.	Qty.
19	Blanket Element, 300 W, 120 V	02.05.738.00	1
20	Air Element, 400 W, 120 V	02.08.647.01	2
21	Thermostat, Electronic	R02.01.273.00	1
22	Transformer, 120-24 V	02.17.022.00	1
23	Thermistor Probe	02.01.203.00	2
24	Surface High Limit, Upper	R02.16.118.00	1
25	Terminal Block	R02.15.046.00	1
26	Cord Grip, Straight	R02.20.259.00	1
27	Power Cord, Right Angle	R02.18.130.00	1
28	Splash Guard	04.48.974.00	1
29	Drip Tray Assembly	04.48.562.00	1
30	Tubing *	03.40.146.00	1'
31	Drain Clamp	03.02.085.00	1
32	Drip Tray Skirt Cover	04.48.750.00	1
33	Bracket, Probe	04.48.728.00	1
34	Surface High Limit, Lower	R02.16.036.00	1
35	Caster, 4", Rigid	04.26.003.00	2
36	Caster, 4", Swivel	04.26.004.00	2
	Wiring Diagram	10-01-1008	

† Includes Items 8, 10, and 11.

* Sold by the foot.

NOTE: The last four digits in a ten digit numerical serial number are the manufacturing date code.

Example: Serial number 9625060951 has a date code of "0951" which indicates the following: 0951

└─ Week Fifty-One
└─ Year 2009



Use of replacement parts other than those supplied by Hatco Corporation may result in damage to the unit or injury to personnel and will void all warranties.



24 Hour 7 Day Parts and Service Assistance available in the United States and Canada by calling 800-558-0607.

AUTHORIZED PARTS DISTRIBUTORS • AUTORISÉS DISTRIBUTEURS DE PIÈCES

ALABAMA

Jones McLeod Appl. Svc.
Birmingham 205-251-0159

ARIZONA

Service Solutions Group
Phoenix 602-234-2443

Byassee Equipment Co.
Phoenix 602-252-0402

CALIFORNIA

Industrial Electric
Commercial Parts & Service, Inc.
Huntington Beach 714-379-7100

Chapman Appl. Service
San Diego 619-298-7106

P & D Appliance
Commercial Parts & Service, Inc.
S. San Francisco 650-635-1900

COLORADO

Hawkins Commercial Appliance
Englewood 303-781-5548

FLORIDA

Whaley Foodservice Repair
Jacksonville 904-725-7800

3Wire Nass Service Co., Inc.
Orlando 407-425-2681

B.G.S.I.
Pompano Beach 954-971-0456

Comm. Appliance Service
Tampa 813-663-0313

GEORGIA

TWC Services
Mableton 770-438-9797

Heritage Service Group
Norcross 866-388-9837

Southeastern Rest. Svc.
Norcross 770-446-6177

HAWAII

Burney's Comm. Service, Inc.
Honolulu 808-848-1466

Food Equip Parts & Service
Honolulu 808-847-4871

ILLINOIS

Parts Town
Lombard 708-865-7278

Eichenauer Elec. Service
Decatur 217-429-4229

Midwest Elec. Appl. Service
Elmhurst 630-279-8000

Cone's Repair Service
Moline 309-797-5323

INDIANA

GCS Service
Indianapolis 800-727-8710

IOWA

Goodwin Tucker Group
Des Moines 515-262-9308

KENTUCKY

Service Solutions Group
Lexington 859-254-8854

Service Solutions Group
Louisville 502-451-5411

LOUISIANA

Chandlers Parts & Service
Baton Rouge 225-272-6620

MARYLAND

Electric Motor Service
Baltimore 410-467-8080

GCS Service
Silver Spring 301-585-7550

MASSACHUSETTS

Ace Service Co., Inc.
Needham 781-449-4220

MICHIGAN

Bildons Appliance Service
Detroit 248-478-3320

Commercial Kitchen Service
Bay City 989-893-4561

Midwest Food Equip. Service
Grandville 616-261-2000

MINNESOTA

GCS Service
Minnetonka 800-822-2303
x20365

MISSOURI

General Parts
Kansas City 816-421-5400

Commercial Kitchen Services
St. Louis 314-890-0700

Kaemmerlen Parts & Service
St. Louis 314-535-2222

NEBRASKA

Anderson Electric
Omaha 402-341-1414

NEVADA

Burney's Commercial
Las Vegas 702-736-0006

Hi. Tech Commercial Service
N. Las Vegas 702-649-4616

NEW JERSEY

Jay Hill Repair
Fairfield 973-575-9145

Service Plus
Flanders 973-691-6300

NEW YORK

Acme American Repairs, Inc.
Brooklyn 718-456-6544

Alpro Service Co.
Brooklyn 718-386-2515

Appliance Installation
Buffalo 716-884-7425

Duffy's Equipment Services, Inc.
Buffalo 800-836-1014

3Wire Northern
Plattsburgh 800-634-5005

Duffy's Equipment Services, Inc.
Sauquoit 800-836-1014

J.B. Brady, Inc.
Syracuse 315-422-9271

NORTH CAROLINA

Authorized Appliance
Charlotte 704-377-4501

OHIO

Akron/Canton Comm. Svc. Inc.
Akron 330-753-6634

Service Solutions Group
Cincinnati 513-772-6600

Commercial Parts and Service
Columbus 614-221-0057

Electrical Appl. Repair Service
Brooklyn Heights 216-459-8700

E. A. Wichman Co.
Toledo 419-385-9121

OKLAHOMA

Hagar Rest. Service, Inc.
Oklahoma City 405-235-2184

Krueger, Inc.
Oklahoma City 405-528-8883

OREGON

Ron's Service, Inc.
Portland 503-624-0890

PENNSYLVANIA

Elmer Schultz Services
Philadelphia 215-627-5401

FAST Comm. Appl. Service
Philadelphia 215-288-4800

Appliance Installation & Service
Pittsburgh 412-809-0244

K & D Service Co.
Harrisburg 717-236-9039

Electric Repair Co.
Reading 610-376-5444

RHODE ISLAND

Marshall Electric Co.
Providence 401-331-1163

SOUTH CAROLINA

Whaley Foodservice Repair
Lexington 803-996-9900

TENNESSEE

Camp Electric
Memphis 901-527-7543

TEXAS

GCS Service
Fort Worth 800-433-1804

Armstrong Repair Service
Houston 713-666-7100

Cooking Equipment Specialist
Mesquite 972-686-6666

Commercial Kitchen Repair Co.
San Antonio 210-735-2811

UTAH

La Monica's Rest. Equip. Service
Murray 801-263-3221

VIRGINIA

Daubers
Norfolk 757-855-4097

Daubers
Springfield 703-866-3600

WASHINGTON

3Wire Restaurant Appliance
Seattle 800-207-3146

WISCONSIN

A.S.C., Inc.
Madison 608-246-3160

A.S.C., Inc.
Milwaukee 414-543-6460

CANADA

ALBERTA

Key Food Equipment Service
Edmonton 780-438-1690

BRITISH COLUMBIA

Key Food Equipment Service
Vancouver 604-433-4484

Key Food Equipment Service
Victoria 250-920-4888

MANITOBA

Air Rite, Inc.
Winnipeg 204-895-2300

NEW BRUNSWICK

EMR Services, Ltd.
Moncton 506-855-4228

ONTARIO

R.G. Henderson Ltd.
Toronto 416-422-5580

Choquette - CKS, Inc.
Ottawa 613-739-8458

QUÉBEC

Choquette - CKS, Inc.
Montreal 514-722-2000

Choquette - CKS, Inc.
Québec City 418-681-3944

UNITED KINGDOM

Marren Group
Northants +44(0)1933 665313

HATCO CORPORATION

P.O. Box 340500

Milwaukee, WI 53234-0500 U.S.A.

800-558-0607 414-671-6350

Parts and Service Fax 800-690-2966

International Fax 414-671-3976

partsandservice@hatcocorp.com

www.hatcocorp.com

Register your unit online!

See IMPORTANT OWNER INFORMATION
section for details.