



**IMPORTANT NOTE:**

Locate the Specification Label on unit to determine exact Model Name and electrical specifications. This information is needed to identify the correct replacement parts. See exploded view illustration(s) for Specification Label location.



Use of replacement parts other than those supplied by Hatco Corporation may result in damage to unit or injury to personnel and will void all warranties.

# Flav-R-Savor®

## Portable Humidified Holding Cabinets

### FSHC-6W Series

<u>Model Name</u>	<u>Page</u>
FSHC-6W1 .....	2
FSHC-6W2 .....	2

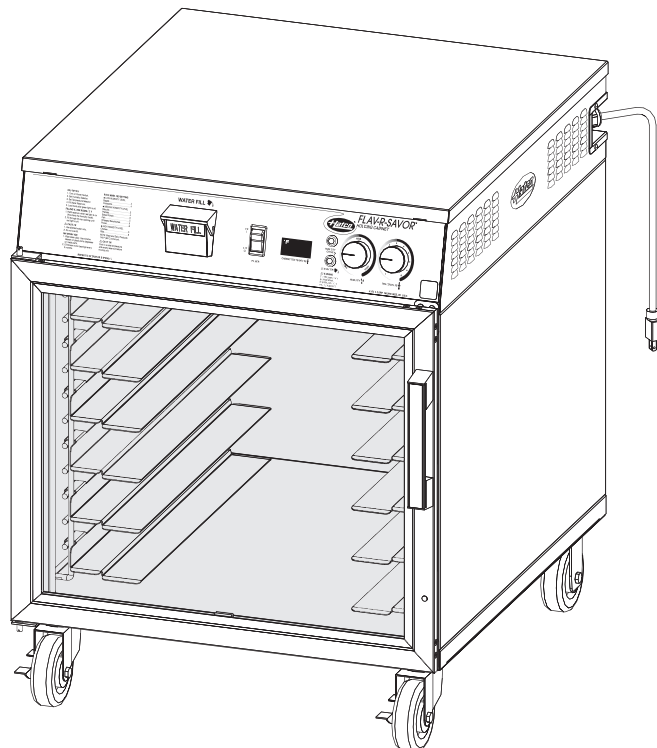

# Replacement Parts List

# Flav-R-Savor® Portable Humidified Holding Cabinets

## FSHC-6W Series

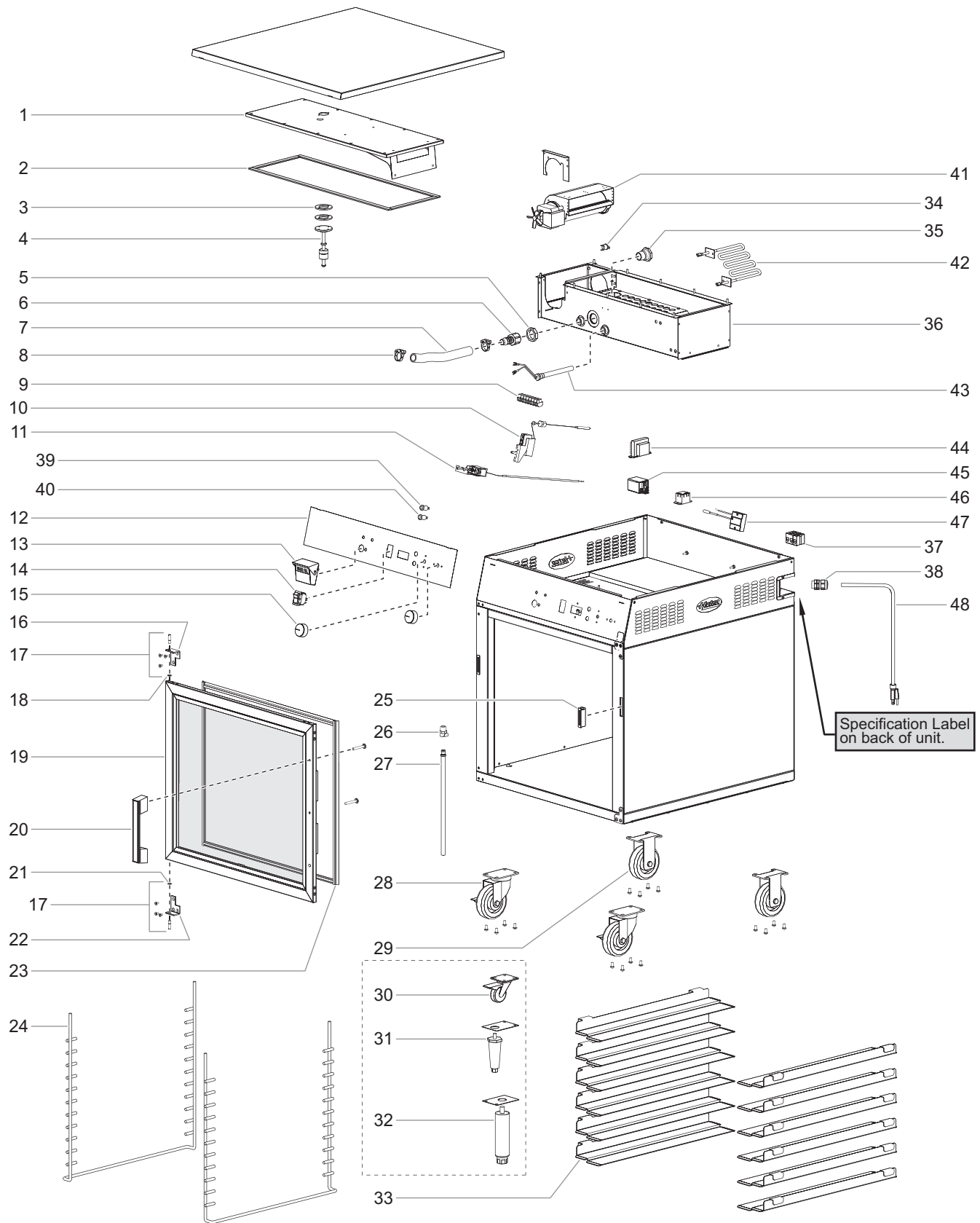

## Parts Common To All Models

Item	Description	Part No.	Qty.
1	Cover Assembly, Heat Chamber	04.17.819.00	1
2	Gasket, Heat Chamber *	05.06.028.00	6'
3	Gasket, Float Switch	05.06.080.00	2
4	Float Switch w/Gaskets	R02.01.029.00	1
5	Jam Nut, Hose Fitting, 3/4"	03.40.023.00	1
6	Hose Fitting Assembly, 3/4" (includes items 5, 34)	R03.40.058.00	1
7	Hose, 1"	03.40.051.00	1
8	Hose Clamp	05.04.354.00	2
9	Terminal Block, 8 Pole	R02.15.049.00	1
10	Thermostat Control, Humidity	02.16.021.00	1
11	Thermostat Control, Temperature	02.16.002.00	1
12	Decal, Control Panel	07.01.308.00	1
13	Fill Cup Assembly	R05.30.050.00	1
14	Rocker Switch, On/Off	02.19.015.00	1
15	Knob, Thermostat	05.30.019.00	2
16	Hinge, Glass Door, Top	04.17.810.00	1-2
17	Hinge Kit, (includes items 16, 18, 21, 22)	R00.01.0133.00	1-2
18	Nylon Washer, Thin	05.11.006.00	1-2
19	Door Kit, Glass (standard, includes items 16, 18, 20, 21, 22, 25)	R00.01.0126.00	1-2
	Door Kit, Stainless Steel (optional, includes items 16, 18, 20, 21, 22, 25) †	R00.01.0128.00	1-2

Item	Description	Part No.	Qty.
20	Door Handle (includes screws)	R05.30.012.00	1-2
21	Nylon Washer, Thick	05.11.007.00	1-2
22	Hinge, Glass Door, Bottom	04.17.811.00	1-2
23	Gasket Kit, Door	R00.01.0127.00	1-2
24	Wire Rack	04.48.527.00	2
25	Magnet, Door	05.30.005.00	4
26	Drain Shutoff Coupling	R03.40.055.00	1
27	Drain Hose Assembly	R03.40.054.00	1
28	Caster, 4", Swivel (standard)	04.26.004.00	2
29	Caster, 4", Rigid (standard)	04.26.003.00	2
30	Caster, 2", Swivel (optional)	04.17.733.00	4
31	Leg, 4" (optional)	05.30.007.00	4
32	Leg, 6" Stainless Steel (optional)	04.16.488.00	4
33	Shelf, Adjustable	04.17.1380.00	12
34	High-Limit Thermostat	02.16.120.00	1
35	Bulkhead Fitting, 3/4"	03.40.022.00	1
36	Heat Chamber Assembly	04.17.735.01	1
37	Terminal Block, 3 Pole	R02.15.046.00	1
38	Cord Grip	R02.20.259.00	1

\* Item sold in one foot increments.

† Not shown.

NOTE: Quantities shown as a range (example = "1-2") are dependent upon the number of doors on a unit.

## Voltage-Specific Parts For All Models

Item	Description	120 V	220 V	240 V	220-230 V (CE)	230-240 V (CE)
39	Indicator Light, Green	02.19.155.00	02.19.150.00	02.19.150.00	02.19.150.00	02.19.150.00
40	Indicator Light, Red	02.19.154.00	02.19.151.00	02.19.151.00	02.19.151.00	02.19.151.00
41	Blower Motor	R02.12.066.00	R02.12.066.01	R02.12.066.01	R02.12.066.01	R02.12.066.01
42	Air Element, 1050 W	R02.08.570.01	R02.08.570E.02	R02.08.570E.03	R02.08.570E.03	R02.08.570E.03
43	Water Element, 600 W	R02.05.002.00	R02.05.018.00	R02.05.003.00	R02.05.018.00	R02.05.003.00
44	Transformer, 24 V	02.17.022.00	02.17.040.00	02.17.040.00	02.17.035.00	02.17.035.00
45	Control Relay					
	Quantity = 1	02.01.028.00	02.01.043.00	02.01.043.00		
	Quantity = 2				02.01.147.00	02.01.147.00
46	Relay, Mini	02.01.088.00	02.01.180.00	02.01.105.00	02.01.180.00	02.01.105.00
47	Temperature Display w/Probe	R02.16.057.00	R02.16.058.00	R02.16.058.00	R02.16.058.00	R02.16.058.00
48	Power Cord w/Plug	02.18.084.00	02.18.109.00	02.18.120.00	02.18.109.00	02.18.120.00
	NEMA 5-15P	R02.18.154.00				
	CEE 7/7 Schuko		02.18.077.00		02.18.077.00	
	BS-1363			02.18.068.00		02.18.068.00
	AS 3112 (Australia)			02.18.104.00		
	Wiring Diagram	10-01-065	10-01-203	10-01-203	10-01-203	10-01-203

NOTE: The last four digits in a ten digit numerical serial number are the manufacturing date code.

Example: Serial number 9625061931 has a date code of "1931" which indicates the following: 1931

└─ Week Thirty-One  
└─ Year 2019

# AUTHORIZED PARTS DISTRIBUTORS • AUTORISÉS DISTRIBUTEURS DE PIÈCES

## ALABAMA

Jones McLeod Appl. Svc.  
Birmingham 205-251-0159

## ARIZONA

Tech 24  
Phoenix 602-234-2443

Byassee Equipment Co.  
Phoenix 602-252-0402

## CALIFORNIA

Industrial Electric  
Commercial Parts & Service, Inc.  
Huntington Beach 714-379-7100

Chapman Appl. Service  
San Diego 619-298-7106

P & D Appliance  
Commercial Parts & Service, Inc.  
S. San Francisco 650-635-1900

## COLORADO

Hawkins Commercial Appliance  
Englewood 303-781-5548

## FLORIDA

Whaley Foodservice Repair  
Jacksonville 904-725-7800

Whaley Foodservice Repair  
Orlando 407-757-0851

B.G.S.I./Heritage  
Pompano Beach 954-971-0456

Comm. Appliance Service  
Tampa 813-663-0313

## GEORGIA

Heritage Service Group  
Norcross 866-388-9837

## HAWAII

Burney's Comm. Service, Inc.  
Honolulu 808-848-1466

Food Equip Parts & Service  
Honolulu 808-847-4871

## ILLINOIS

Parts Town  
Addison 708-865-7278

Eichenauer Elec. Service  
Decatur 217-429-4229

Midwest Elec. Appl. Service  
Elmhurst 630-279-8000

Cone's Repair Service  
Moline 309-797-5323

## IOWA

Goodwin Tucker Group  
Des Moines 515-262-9308

## KENTUCKY

Tech 24  
Lexington 859-254-8854

Tech 24  
Louisville 502-451-5411

## LOUISIANA

Chandlers Parts & Service  
Baton Rouge 225-272-6620

## MARYLAND

Electric Motor Service  
Baltimore 410-467-8080

## MASSACHUSETTS

Ace Service Co., Inc.  
Needham 781-449-4220

## MICHIGAN

Bildons Appliance Service  
Detroit 248-478-3320

Commercial Kitchen Service  
Bay City 989-893-4561

Midwest Food Equip. Service  
Grandville 616-261-2000

## MISSOURI

General Parts  
Kansas City 816-421-5400

Commercial Kitchen Services  
St. Louis 314-890-0700

Kaemmerlen Parts & Service  
St. Louis 314-535-2222

## NEBRASKA

Anderson Electric  
Omaha 402-341-1414

## NEVADA

Burney's Commercial  
Las Vegas 702-736-0006

Hi. Tech Commercial Service  
N. Las Vegas 702-649-4616

## NEW JERSEY

Jay Hill Repair  
Fairfield 973-575-9145

Service Plus  
Flanders 973-691-6300

## NEW YORK

Alpro Service Co.  
Maspeth 718-386-2515

Duffy's - AIS  
Buffalo 716-884-7425

3Wire  
Plattsburgh 800-634-5005

Duffy's - AIS  
Sauquoit 800-836-1014

J.B. Brady, Inc.  
Syracuse 315-422-9271

## NORTH CAROLINA

Authorized Appliance  
Charlotte 704-377-4501

## OHIO

Akron/Canton Comm. Svc. Inc.  
Akron 330-753-6634

Tech 24  
Cincinnati 513-772-6600

Commercial Parts and Service  
Columbus 614-221-0057

Electrical Appl. Repair Service  
Brooklyn Heights 216-459-8700

E. A. Wichman Co.  
Toledo 419-385-9121

## OKLAHOMA

Hagar Rest. Service, Inc.  
Oklahoma City 405-235-2184

## OREGON

General Parts Group  
Portland 503-624-0890

## PENNSYLVANIA

Elmer Schultz Services  
Philadelphia 215-627-5401

FAST Comm. Appl. Service  
Philadelphia 215-288-4800

AIS Commercial Parts and Service  
Pittsburgh 412-809-0244

K & D Service Co.  
Harrisburg 717-236-9039

Electric Repair Co.  
Reading 610-376-5444

## RHODE ISLAND

Marshall Electric Co.  
Providence 401-331-1163

## SOUTH CAROLINA

Whaley Foodservice Repair  
Lexington 803-996-9900

## TENNESSEE

Camp Electric  
Memphis 901-527-7543

## TEXAS

Armstrong Repair Service  
Houston 713-666-7100

Cooking Equipment Specialist  
Mesquite 972-686-6666

Commercial Kitchen Repair Co.  
San Antonio 210-735-2811

## UTAH

La Monica's Rest. Equip. Service  
Murray 801-263-3221

## VIRGINIA

Daubers  
Norfolk 757-855-4097

Daubers  
Springfield 703-866-3600

## WASHINGTON

3Wire  
Seattle 800-207-3146

## WISCONSIN

A.S.C., Inc.  
Madison 608-246-3160

A.S.C., Inc.  
Milwaukee 414-543-6460

## CANADA

### ALBERTA

Key Food Equipment Service  
Edmonton 780-438-1690

### BRITISH COLUMBIA

Key Food Equipment Service  
Vancouver 604-433-4484

Key Food Equipment Service  
Victoria 250-920-4888

### MANITOBA

Air Rite, Inc.  
Winnipeg 204-895-2300

### NEW BRUNSWICK

EMR Services, Ltd.  
Moncton 506-855-4228

### ONTARIO

R.G. Henderson Ltd.  
Toronto 416-422-5580

Choquette - CKS, Inc.  
Ottawa 613-739-8458

### QUÉBEC

Choquette - CKS, Inc.  
Montreal 514-722-2000

Choquette - CKS, Inc.  
Québec City 418-681-3944

## UNITED KINGDOM

Marren Group  
Northants +44(0)1933 665313

### HATCO CORPORATION

P.O. Box 340500

Milwaukee, WI 53234-0500 U.S.A.

800-558-0607 414-671-6350

partsandservice@hatcocorp.com

www.hatcocorp.com



24 Hour 7 Day Parts and Service  
Assistance available in the United States  
and Canada by calling 800-558-0607.