



# MACHO NACHO™ Chip Warmer

*FST - MN Series*

---

*FST-1-MN*

---

**REPLACEMENT  
PARTS LIST**

---

# HATCO FLAVOR-SAVOR FST-MN SERIES DISPLAY CABINETS

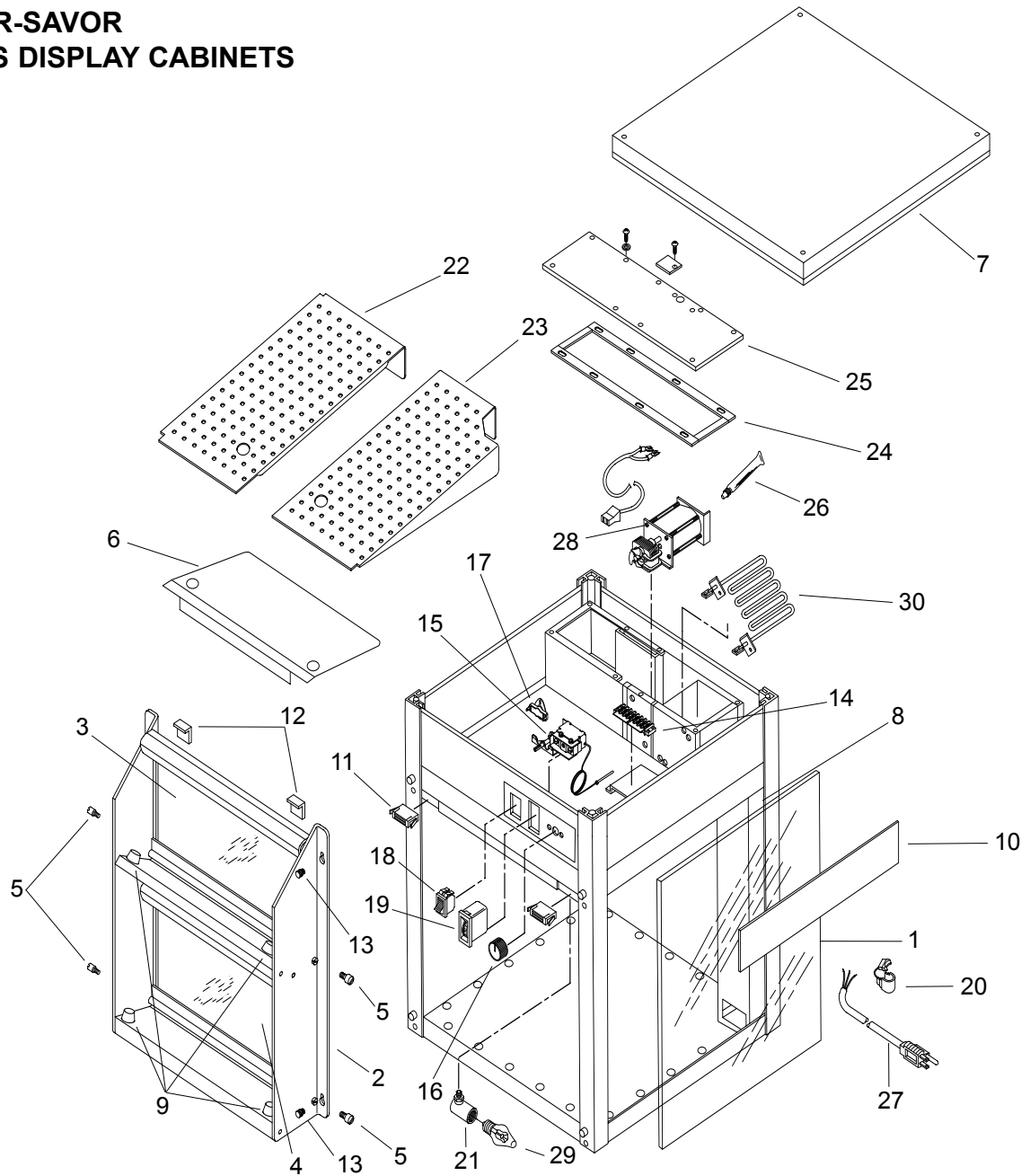

**Model Designation**

**FST-1-MN**

- F = Flav-R
- S = Savor
- T = Tall
- 1 = Number of sides with doors
- M = Macho
- N = Nacho

**CAUTION** - Use of replacement parts other than those supplied by Hatco Corporation may result in damage to the unit or injury to personnel.

### PARTS COMMON TO FST-MN MODELS

ITEM	DESCRIPTION	PART NO.	QTY.	ITEM	DESCRIPTION	PART NO.	QTY.
1	Side Panels, Glass	04.40.008.00	3	11	Door Magnet, Glass Door	05.30.026.00	4
2	Front Face Assembly	04.17.325.00	1		Door Magnet, Upper Door		
3	Upper Door Assembly, Glass	R00.01.0111.00	1		S.S. (not shown)	05.30.026A.00	2
	Upper Door Assembly, S.S. (optional) (not shown)	R04.17.328.00	1		Door Magnet, Lower Door		
4	Lower Door Assembly, Glass	R00.01.0112.00	1	12	Striker Plate	05.30.027.00	4
	Lower Door Assembly, S.S. (optional) (not shown)	R04.17.329.00	1	13	Thumb Screw	05.04.140.00	4
5	Door Hinge Pin, Glass Door	04.24.023.00	4	14	Terminal Block	02.15.012.00	1
	Door Hinge Pin, S.S. Door (optional) (not shown)	05.04.252.00	4	15	Air Thermostat	02.16.002.00	1
6	Chip Deflector	04.17.311.00	1	16	Knob	05.30.019.00	1
7	Top Hood, Painted	04.17.095.00	1	17	High Limit Disk	R02.16.118.00	1
8	Air Diffuser Assembly	04.17.318.00	1	18	On/Off Power Switch	02.19.015.00	1
9	Door Bumper Assembly	R05.30.029.00	4	19	Temperature Display	02.16.049.00	1
10	Display Decal	07.03.220.00	3	20	Cord Grip	02.20.206.00	1
				21	Light Socket with Leads	02.30.039.00	2
				22	Floor Panel, Left	04.17.314.00	1
				23	Floor Panel, Right	04.17.315.00	1
				24	Air Chamber Gasket	05.06.028.00	5' (152 cm)
				25	Air Chamber Cover	04.17.022A.00	1
				26	Lubricant, Blower Motor	05.01.019.00	1

**NOTE:** S.S. is an abbreviation for stainless steel.

### PARTS SPECIFIC TO MODEL **FST-1-MN**

ITEM	DESCRIPTION	120V	220V	240V	220-230V CE	230-240V CE
		60 Hz	50 Hz	50 Hz	50Hz	50 Hz
27	Power Cord and Plug	02.18.035.00	02.18.109.00	02.18.120.00	02.18.109.00	02.18.120.00
28	Blower Motor	R02.12.003.00	R02.12.012.00	R02.12.012.00	R02.12.012.00	R02.12.012.00
29	Light Bulb	02.30.043.00	02.30.058.00	02.30.058.00	02.30.058.00	02.30.058.00
30	Air Heating Element (1050 Watt)	R02.05.007.00	R02.05.017.00	R02.05.008.00	R02.05.017.00	R02.05.008.00
31	Terminal Block (not shown)	---	---	---	R02.15.030.00	R02.15.030.00
	Electrical Drawing	HS1-2613	HS1-3224	HS1-3225	HS1-4710	HS1-4711

Shaded area reflects **export models only**.

## HATCO AUTHORIZED PARTS DISTRIBUTORS

### ALABAMA

Jones McLeod Appl. Svc.  
Birmingham 205-251-0159

### ARIZONA

Auth. Comm. Food Equip.  
Phoenix 602-234-2443  
Byassee Equipment Co.  
Phoenix 602-252-0402

### CALIFORNIA

Industrial Electric  
Huntington Beach 714-379-7100  
Chapman Appl. Service  
San Diego 619-298-7106  
P & D Appliance  
S. San Francisco 650-635-1900

### COLORADO

Hawkins Commercial Appliance  
Englewood 303-781-5548

### DELAWARE

Food Equipment Service  
Wilmington 302-996-9363

### FLORIDA

Whaley Foodservice Repair  
Jacksonville 904-725-7800  
Nass Service Co., Inc.  
Orlando 407-425-2681  
B.G.S.I.  
Pompano Beach 954-971-0456  
Comm. Appliance Service  
Tampa 813-663-0313

### GEORGIA

Southeastern Rest. Svc.  
Norcross 770-446-6177

### HAWAII

Burney's Comm. Service, Inc.  
Honolulu 808-848-1466  
Food Equip Parts & Service  
Honolulu 808-847-4871

### ILLINOIS

Parts Town  
Lombard 708-865-7278  
Eichenauer Elec. Service  
Decatur 217-429-4229  
Midwest Elec. Appl. Service  
Elmhurst 630-279-8000  
Cone's Repair Service  
Moline 309-797-5323

### INDIANA

GCS Service  
Indianapolis 317-545-9655

### IOWA

Electric Motor Service Co.  
Davenport 319-323-1823

### KENTUCKY

GCS Service  
Louisville 502-367-1788

### LOUISIANA

Chandlers Parts & Service  
Baton Rouge 225-272-6620  
Bana Comm. Parts, Inc.  
Shreveport 318-631-6550

### MARYLAND

Electric Motor Service  
Baltimore 410-467-8080  
GCS Service  
Silver Spring 301-585-7550

### MASSACHUSETTS

Ace Service Co., Inc.  
Needham 781-449-4220

### MICHIGAN

Commercial Kitchen Service  
Bay City 517-893-4561  
Bildons Appliance Service  
Detroit 248-478-3320  
Midwest Food Equip. Service  
Grandville 616-261-2000

### MINNESOTA

GCS Service  
Minneapolis 612-546-4221

### MISSOURI

GCS Service  
Kansas City 816-920-5999  
Commercial Kitchen Services  
St. Louis 314-890-0700  
Kaemmerlen Parts & Service  
St. Louis 314-535-2222

### NEBRASKA

Anderson Electric  
Omaha 402-341-1414

### NEVADA

Burney's Commercial  
Las Vegas 702-736-0006  
Hi. Tech Commercial Service  
N. Las Vegas 702-649-4616

### NEW JERSEY

Jay Hill Repair  
Fairfield 973-575-9145  
Service Plus  
Flanders 973-691-6300

### NEW YORK

Acme American Repairs, Inc.  
Brooklyn 718-456-6544  
Alpro Service Co.  
Brooklyn 718-386-2515  
Appliance Installation  
Buffalo 716-884-7425  
Northern Parts Dist.  
Plattsburgh 518-563-3200  
J. B. Brady, Inc.  
Syracuse 315-422-9271

### NORTH CAROLINA

Authorized Appliance  
Charlotte 704-377-4501

### OHIO

Akron/Canton Comm. Svc. Inc.  
Akron 330-753-6635  
Certified Service Center  
Cincinnati 513-772-6600  
GCS Service  
Columbus 614-476-3225  
Electrical Appl. Repair Service  
Independence 216-459-8700  
E. A. Wichman Co.  
Toledo 419-385-9121

### OKLAHOMA

Hagar Rest. Service, Inc.  
Oklahoma City 405-235-2184  
Krueger, Inc.  
Oklahoma City 405-528-8883

### OREGON

Bressie Electric Co.  
Portland 503-231-7171  
Ron's Service, Inc.  
Portland 503-624-0890

### PENNSYLVANIA

Authorized Factory Service  
Coraopolis 412-262-2330  
FAST Comm. Appl. Service  
Philadelphia 215-288-4800  
GCS Service  
Pittsburgh 412-787-1970  
K & D Service Co.  
Harrisburg 717-236-9039  
Elmer Schultz Services  
Philadelphia 215-627-5401  
Electric Repair Co.  
Reading 610-376-5444

### RHODE ISLAND

Marshall Electric Co.  
Providence 401-331-1163

### SOUTH CAROLINA

Whaley Foodservice Repair  
W. Columbia 803-791-4420

### TENNESSEE

Camp Electric  
Memphis 901-527-7543

### TEXAS

Stove Parts Supply  
Fort Worth 817-831-0381  
Armstrong Repair Service  
Houston 713-666-7100  
Commercial Kitchen Repair Co.  
San Antonio 210-735-2811  
San Antonio Rest. Equip.  
San Antonio 210-532-1660

### UTAH

GCS Service  
Salt Lake City 801-487-3653

### VIRGINIA

Daubers  
Norfolk 757-855-4097  
Daubers  
Springfield 703-866-3600

### WASHINGTON

Restaurant Appl. Service  
Seattle 206-524-8200

### WISCONSIN

A.S.C., Inc.  
Madison 608-246-3160  
A.S.C., Inc.  
Milwaukee 414-543-6460

## CANADA

### BRITISH COLUMBIA

Key Food Equipment Service  
Vancouver 604-433-4484

### ONTARIO

R.G. Henderson Ltd.  
Toronto 416-422-5580

## HATCO CORPORATION

P.O. Box 340500, Milwaukee, WI 53234-0500 U.S.A.

(800) 558-0607 (414) 671-6350

Parts & Service Fax (800) 690-2966 Int'l. Fax (414) 671-3976

www.hatcocorp.com