

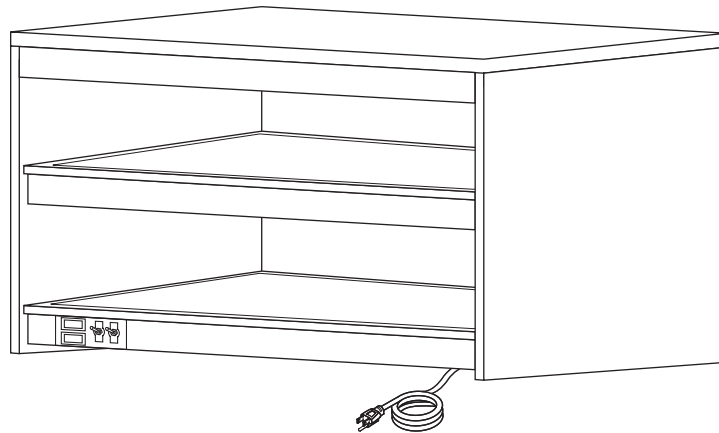

Burger King™ Glo-Ray® Sandwich Display Warmer GRSDS Series

Installation & Operating Manual & Replacement Parts List

I&W #07.05.180.00



This manual contains important safety information concerning the maintenance, use and operation of this product. Failure to follow the instructions contained in this manual may result in serious injury. If you're unable to understand the contents of this manual, please bring it to the attention of your supervisor. Do not operate this equipment unless you have read and understood the contents of this manual.

Este manual contiene importante información sobre seguridad concerniente al mantenimiento, uso y operación de este producto. Cualquier falla en el seguimiento de las instrucciones contenidas en este manual puede resultar en un serio daño. Si usted no puede entender el contenido de este manual por favor pregunte a su supervisor. No opere este equipo al menos que haya leído y comprendido el contenido de este manual.

CONTENTS

Important Owner Information.....	i	Operation	5
Introduction	i	General.....	5
Important Safety Information	1	Maintenance	6
Model Description	2	Cleaning	6
Specifications	2	Display Light Bulb Replacement.....	6
Plug Configurations.....	2	Accessories	7
Dimensions.....	2	Replacement Parts List	8
Electrical Rating Chart	3	Hatco Limited Warranty	11
Installation	4	Authorized Parts Distributors	Back Cover
Unpacking	4		
Location.....	4		

IMPORTANT OWNER INFORMATION

Record the model number, serial number (identification plate located on the rear of the unit), voltage and purchase date of your Glo-Ray® Sandwich Display Warmer in the spaces below. Please have this information available when calling Hatco for service assistance.

Model No. _____

Serial No. _____

Voltage _____

Date of Purchase _____

Business Hours: 8:00 a.m. to 5:00 p.m.
Central Standard Time

(Summer Hours: June to September –
8:00 a.m. to 5:00 p.m. C.D.T.
Monday through Thursday
8:00 a.m. to 2:30 p.m. C.D.T. Friday)

Telephone: (800) 558-0607; (414) 671-6350

Fax: (800) 690-2966 (Parts & Service)
(414) 671-3976 (International)





24 Hour 7 Day Parts & Service Assistance available in the United States and Canada by calling (800) 558-0607.

Additional information can be found by visiting our web site at www.hatcocorp.com.

INTRODUCTION

The Burger King Glo-Ray Sandwich Display Warmers, are perfect for holding wrapped sandwiches or boxed foods on a buffet line or at temporary serving areas. These warmers hold hot wrapped products and keep them at optimum serving temperatures without affecting quality. Prefocused infrared heat from above and thermostatically controlled heat extends the holding times of most wrapped food. The infrared heating elements are guaranteed against burnout and breakage for two years. These units also feature incandescent lights along with a cord and plug set.

This manual provides the installation, safety and operating instructions for the Glo-Ray Sandwich Display Warmers. We recommend all installation, operating and safety instructions appearing in this manual be read prior to installation or operation of

your Display Warmer. Safety instructions that appear in this manual after a warning symbol  and the words **WARNING** or **CAUTION** printed in bold face are very important.  **WARNING** means there is the possibility of serious injury or death to yourself or others.  **CAUTION** means there is the possibility of minor or moderate injury. **NOTICE** without the symbol signifies the possibility of equipment or property damage only.

The Burger King Glo-Ray Sandwich Display Warmer is a product of extensive research and field testing. The materials used were selected for maximum durability, attractive appearance and optimum performance. Every unit is thoroughly inspected and tested prior to shipment.

IMPORTANT SAFETY INFORMATION

IMPORTANT! Read the following important safety information to avoid personal injury or death, and to avoid damage to the equipment or property.

⚠ WARNINGS

- ⚠ To avoid any injury, turn the power switch OFF unplug the unit from the power source and allow to cool completely before performing any maintenance and cleaning.**
- ⚠ Plug unit into a properly grounded electrical outlet of the correct voltage, size and plug configuration. If the plug and receptacle do not match, contact a qualified electrician to determine the proper voltage and size and install the proper electrical outlet.**
- ⚠ To avoid electrical shock or personal injury, do not steam clean or use excessive water on the unit.**
- ⚠ To prevent any injury or damage to the unit do not pull unit by power cord.**
- ⚠ To prevent any injury, discontinue use if power cord is frayed or worn.**
- ⚠ Unit is not waterproof. DO NOT submerge in water. Do not operate if unit has been submerged in water.**
- ⚠ Some exterior surfaces on the unit will get hot. Use caution when touching these areas to avoid injury.**
- ⚠ For safe and proper operation, the unit must be located a minimum of 1" (25 mm) from combustible walls and materials. If safe distances are not maintained, discoloration or combustion could occur.**
- ⚠ Only light bulbs which meet or exceed NSF standards, specifically designed for food holding areas may be used. Breakage of light bulbs not specially coated could result in personal injury and/or food contamination.**
- ⚠ If service is required on this unit, contact your Authorized Hatco Service Agent, or contact the Hatco Service Department at 800-558-0607 or 414-671-6350; fax 800-690-2966 or International fax 414-671-3976.**
- ⚠ This product has no "user" serviceable parts. To avoid damage to the unit or injury to personnel, use only Authorized Hatco Service Agents and Genuine Hatco Parts when service is required.**

- ⚠ Genuine Hatco Replacement Parts are specified to operate safely in the environments in which they are used. Some aftermarket or generic replacement parts do not have the characteristics that will allow them to operate safely in Hatco equipment. It is essential to use Hatco Replacement Parts when repairing Hatco equipment. Failure to use Hatco Replacement Parts may subject operators of the equipment to hazardous electrical voltage, resulting in electrical shock or burn.**

⚠ CAUTIONS

- ⚠ Unit is not weatherproof. For safe and proper operation, locate the unit indoors where the ambient air temperature is constant and is a minimum of 70°F (21°C).**
- ⚠ To avoid any injury or damage, locate the unit at the proper counter height, in an area that is convenient for use. The location should be level to prevent the unit or its contents from accidentally falling, and strong enough to support the weight of the unit and food.**
- ⚠ Do not lay unit on the side with the control panel or damage to unit could occur.**

NOTICE

Use only non-abrasive cleaners. Abrasive cleaners could scratch the finish of your unit, marring its appearance and making it susceptible to dirt accumulation.

MODEL DESCRIPTION

ALL MODELS

The Burger King Glo-Ray® Sandwich Display Warmers are constructed of aluminum and features temperature controlled heated slanted shelves. The slanted shelves, incandescent lights, and product divider bars provide an ideal holding area for wrapped foods. The infrared heating elements provide optimum serving temperatures. All models are equipped with legs and a cord and plug set.

These models can be ordered in various widths, 36" (914 mm), 41" (1041 mm) and 52" (1321 mm). Optional 4" (102 mm) adjustable legs are available.

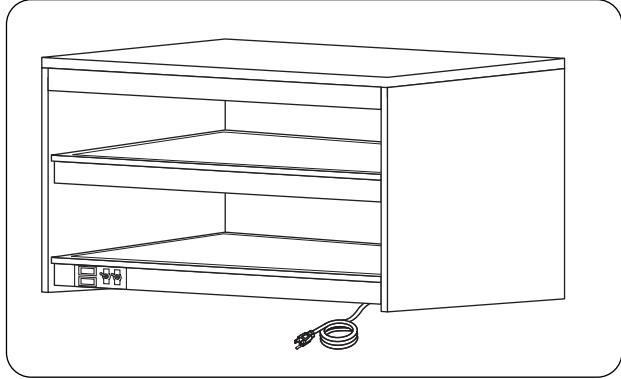

Figure 1. GRSDS-36DBK Model

SPECIFICATIONS

PLUG CONFIGURATIONS

Units are supplied from the factory with an electrical cord and plug installed. Plugs are supplied according to the applications. (See Figure 2.)

⚠ WARNING

Plug unit into a properly grounded electrical outlet of the correct voltage, size and plug configuration. If the plug and receptacle do not match, contact a qualified electrician to determine the proper voltage and size and install the proper electrical outlet.

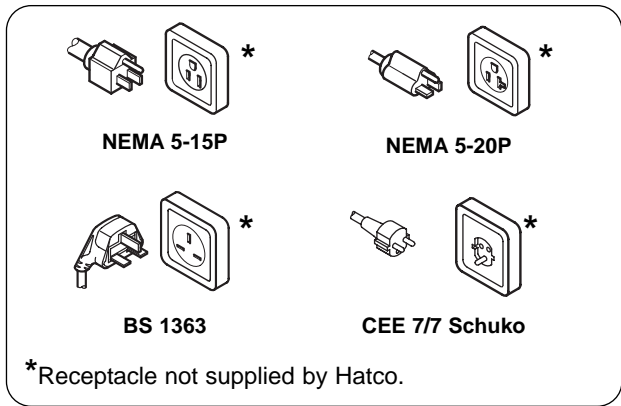

*Receptacle not supplied by Hatco.

Figure 2. Plug Configurations

DIMENSIONS

Model	Width (A)	Depth (B)	Height (C)
GRSDS-36DBK	36" (914 mm)	24" (610 mm)	29-3/8" (746 mm)
GRSDS-41DBK	41" (1041 mm)	24" (610 mm)	29-3/8" (746 mm)
GRSDS-52DBK	52" (1321 mm)	24" (610 mm)	29-3/8" (746 mm)

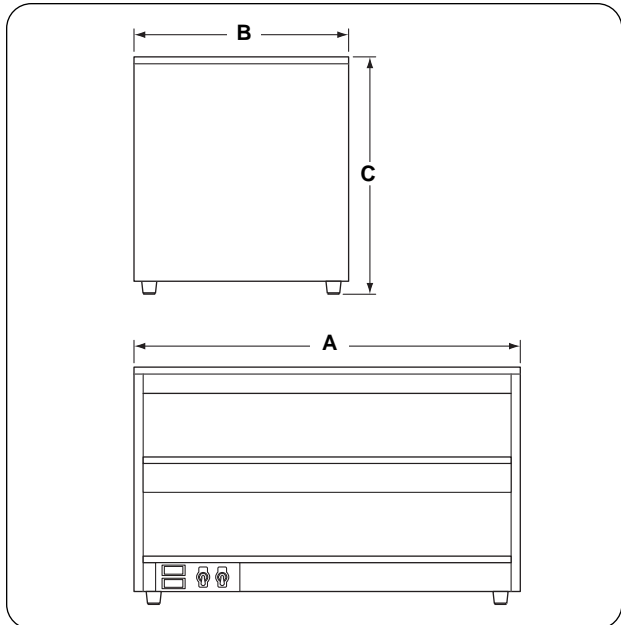

Figure 3. Dimensions - GRSDS Series

SPECIFICATIONS

ELECTRICAL RATING CHART

Model	Voltage	Watts	Amps	Plug Configuration	Shipping Weight
GRSDS-36DBK	120	1980	16.5	NEMA 5-20P	216 lbs. (98 kg)
	220	1920	8.7	CEE 7/7 Schuko	216 lbs. (98 kg)
	240	1980	8.3	BS 1363	216 lbs. (98 kg)
GRSDS-41DBK	120	1100	9.2	NEMA 5-15P	240 lbs. (109 kg)
		(Circuit 1) 1160	9.7	NEMA 5-15P	
	220	1070	4.9	CEE 7/7 Schuko	240 lbs. (109 kg)
		(Circuit 1) 1130	5.1	CEE 7/7 Schuko	
	240	1100	4.6	BS 1363	240 lbs. (109 kg)
		(Circuit 1) 1160	4.8	BS 1363	
GRSDS-52DBK	120	1405	11.7	NEMA 5-15P	275 lbs. (125 kg)
		(Circuit 1) 1480	12.3	NEMA 5-15P	
	220	1365	6.2	CEE 7/7 Schuko	275 lbs. (125 kg)
		(Circuit 1) 1440	6.5	CEE 7/7 Schuko	
	240	1405	5.9	BS 1363	275 lbs. (125 kg)
		(Circuit 1) 1480	6.2	BS 1363	
		(Circuit 2)			

The electrical information in the shaded areas pertains to **Export models only**.

NOTE: Shipping weight includes packaging.

NOTE: Units listed with two circuits, Circuit 1 & Circuit 2, have two power cords attached and require two separate receptacles.

INSTALLATION

UNPACKING

The Burger King Glo-Ray® Sandwich Display Warmer is shipped with all components pre-assembled. Care should be taken when unpacking shipping carton to avoid damage to unit and components enclosed.

⚠ WARNING

To prevent any injury or damage to the unit do not pull unit by power cord.

⚠ WARNING

To prevent any injury, discontinue use if power cord is frayed or worn.

1. Remove the unit from the carton.
2. Remove information packet. **To prevent delay in obtaining warranty coverage, fill out and mail in the warranty card.**
3. Remove tape and protective packaging from all surfaces of unit.

⚠ CAUTION

Do not lay unit on the side with the control panel or damage to the unit could occur.

4. Carefully lay unit on a side without the controls (requires two people). Install rubber feet to each leg, then install one leg in each corner of the cabinet bottom. Return unit to the upright position. (See Figure 4.)
5. This unit is supplied with product divider bars. To install them, simply place the bars in the channels provided. The bars can be readily adjusted to separate the holding areas as needed. (See Figure 5.)

LOCATION

For proper operation and maximum performance, locate the unit in an area where the ambient air temperature is constant and is a minimum of 70°F (21°C). Areas which are susceptible to active air movements or currents should be avoided, i.e., near exhaust fans or hoods and air conditioning ducts.

⚠ WARNING

For safe and proper operation, the unit must be located a minimum of 1" (25 mm) from combustible walls and materials. If safe distances are not maintained, discoloration or combustion could occur.

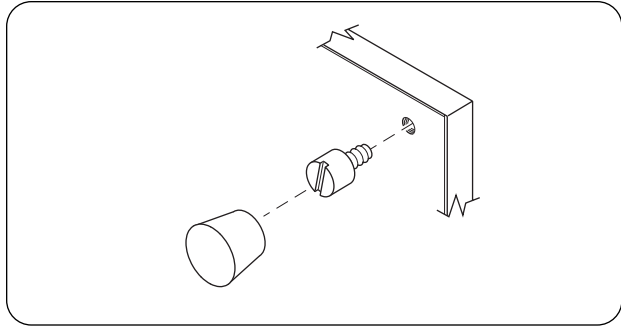

Figure 4. Leg Installation

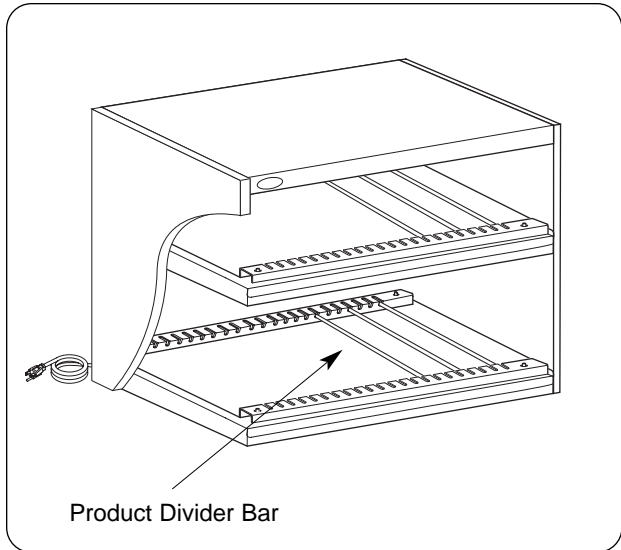

Figure 5. Installing Product Divider Bars

⚠ CAUTION

Unit is not weatherproof. For safe and proper operation, locate the unit **indoors** where the ambient air temperature is constant and is a minimum of 70°F (21°C).

⚠ CAUTION

To avoid any injury or damage, locate the unit at the proper counter height, in an area that is convenient for use. The location should be level to prevent the unit or its contents from accidentally falling, and strong enough to support the weight of the unit and food displayed.

OPERATION

GENERAL

⚠ WARNING

Unit is not waterproof. **DO NOT** submerge in water. Do not operate if it has been submerged in water.

⚠ WARNING

Some exterior surfaces on the unit will get hot. Use caution when touching these areas to avoid injury.

1. Plug unit into a properly grounded electrical outlet of the correct voltage, size and plug configuration. See *SPECIFICATIONS* for details.
2. Turn the two toggle switches on the control panel to the ON position. (See Figure 6.)

3. Adjust the Temperature Controllers as follows:

To set temperature, turn the red Mode Switch counterclockwise to the SP-1 position indicated on the controller.

Adjust the Setpoint Screw to the desired temperature and turn the red Mode Switch to the TEMP position. The surface temperature range is room temperature to 200°F (93.3°C). See *BURGER KING OPERATIONS MANUAL* for recommended setpoint.

4. Allow 15-20 minutes for unit to reach operating temperature.

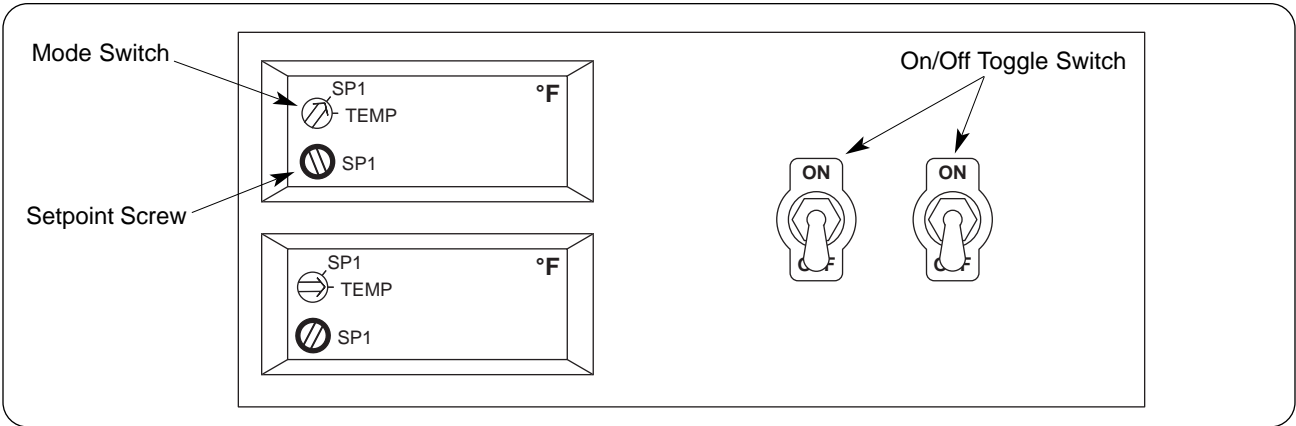

Figure 6. Control Panel

MAINTENANCE

CLEANING

The Sandwich Display Warmer is designed for maximum durability and performance, with minimum maintenance.

WARNING

To avoid any injury, turn the power switch OFF unplug the unit from the power source and allow to cool completely before performing any maintenance and cleaning.

WARNING

Units are not waterproof. DO NOT submerge in water. Do not operate if unit has been submerged in water.

To preserve the bright finish of the Display Warmer, it is recommended that the exterior and interior surfaces be wiped daily with a damp cloth. Stubborn stains may be removed with a good stainless steel cleaner or a non-abrasive cleaner. Hard-to-reach areas should be cleaned with a small brush and mild soap.

WARNING

To avoid electrical shock or personal injury, do not steam clean or use excessive water on the unit.

NOTICE

Use only non-abrasive cleaners. Abrasive cleaners could scratch the finish of your unit cabinet marring its appearance and making it susceptible to soil accumulation.

DISPLAY LIGHT BULB REPLACEMENT

The display light is an incandescent light bulb which illuminates the warming area. The bulb has a special coating to guard against injury and food contamination in the event of breakage.

1. To replace a light bulb, disconnect the power supply and wait until the unit has cooled.
2. Light bulbs have a threaded base. Unscrew the light bulb from the unit and replace it with a new specially-coated incandescent light bulb.

Note: Hatco shatter-resistant light bulbs meet NSF standards for food holding and display areas. For 120, 120/208 and 120/240 volt applications, use Hatco part number [02.30.043.00](#). For 220 or 240 volt applications, use Hatco part number [02.30.058.00](#).

WARNING

Only light bulbs which meet or exceed NSF standards, specifically designed for food holding areas may be used. Breakage of light bulbs not specially coated could result in personal injury and/or food contamination.

WARNING

If service is required on this unit, contact your Authorized Hatco Service Agent, or contact the Hatco Service Department at 800-558-0607 or 414-671-6350; fax 800-690-2966 or International fax 414-671-3976.

WARNING

This product has no "user" serviceable parts. To avoid damage to the unit or injury to personnel, use only Authorized Hatco Service Agents and Genuine Hatco Parts when service is required.

WARNING

Genuine Hatco Replacement Parts are specified to operate safely in the environments in which they are used. Some aftermarket or generic replacement parts do not have the characteristics that will allow them to operate safely in Hatco equipment. It is essential to use Hatco Replacement Parts when repairing Hatco equipment. Failure to use Hatco Replacement Parts may subject operators of the equipment to hazardous electrical voltage, resulting in electrical shock or burn.

4" (102 MM) ADJUSTABLE LEGS

⚠ CAUTION

Do not lay unit on the side with the control panel or damage to unit could occur.

Carefully lay unit on its side. Install legs to bottom of unit. (See Figure 7.) Hand tighten legs until snug. Do not overtighten. Return unit to the upright position.

NOTE: Legs are adjustable for leveling the unit. Use a 5/8" (16 mm) open-end wrench to make leveling adjustments once the unit is placed in final position.

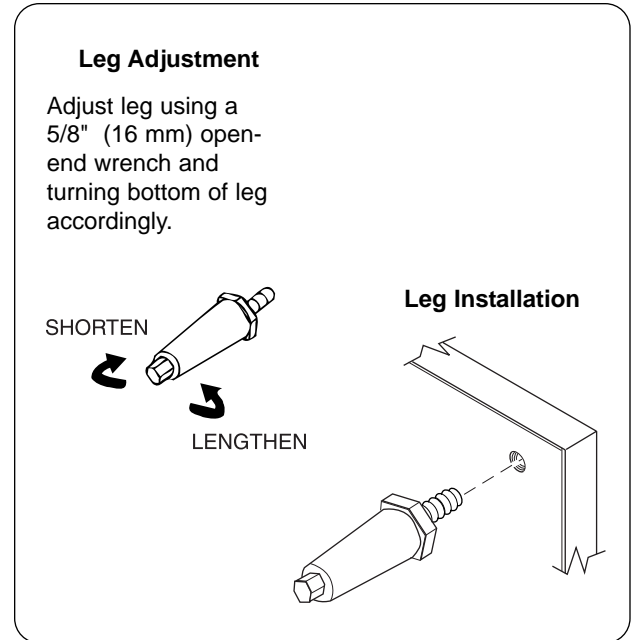

Figure 7. Adjustable Legs

REPLACEMENT PARTS LIST

Burger King Glo-Ray® Sandwich Display Warmer GRSDS Series

⚠ CAUTION - Use of replacement parts other than those supplied by Hatco Corporation may result in damage to the unit or injury to personnel.

Model Designation

GRSDS-XXDBK

- G = Glo
- R = Ray
- S = Sandwich
- D = Display
- S = Slanted Shelf
- X = Width in Inches
- D = Dual Shelf
- B = Burger
- K = King

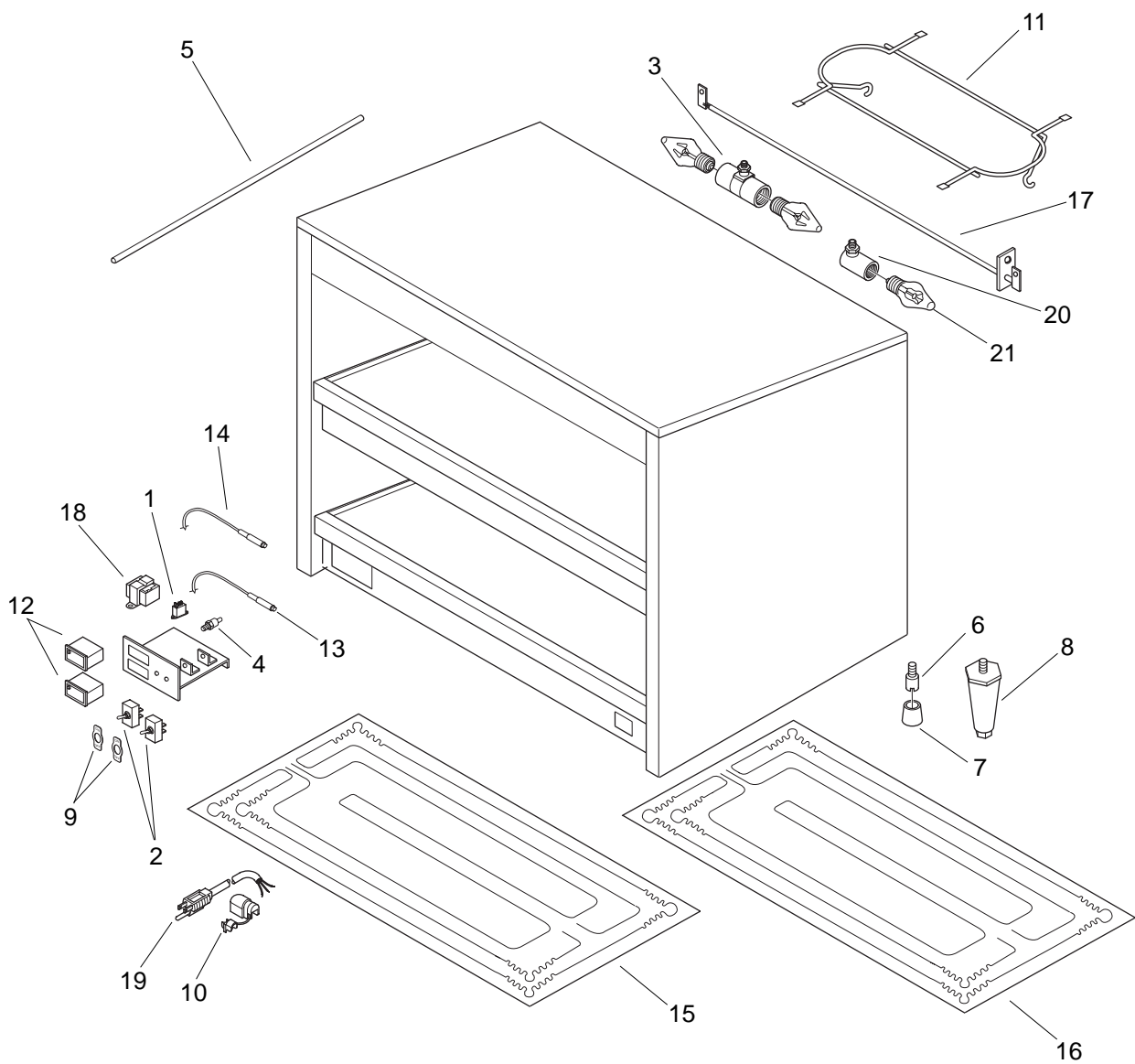

REPLACEMENT PARTS LIST

PARTS COMMON TO ALL GRSDS MODELS

ITEM	DESCRIPTION	PART NO.	QTY.
1	Relay, 10 Amp, SPDT, 24VDC	02.01.061.00	4
2	On/Off Toggle Switch	R02.19.016.00	2
3	Light Socket, Dual with Leads	02.30.045.00	2-4
4	Diode Assembly	R02.40.047.00	2
5	Divider Rod	04.15.873.00	14-20
6	Leg	05.04.087.00	4
7	Rubber Foot Cover	05.06.038.00	4
8	Appliance Leg, 4" (102 mm)	05.30.007.00	4
9	Indicator, Toggle Switch	07.01.058.00	2
10	Strain Relief for Cord	02.20.206.00	1-2
11	Wire Guard for Heating Element	04.37.100.00	8-16

PARTS SPECIFIC TO ALL GRSDS-36DBK MODELS

ITEM	DESCRIPTION	120V	220V	240V
12	Electronic Temperature Controller	02.01.049.00	R02.01.062.00	R02.01.062.00
13	Temperature Probe - Bottom Shelf	02.01.056.00	02.01.078.00	02.01.078.00
14	Temperature Probe - Top Shelf	02.01.057.00	02.01.079.00	02.01.079.00
15	Blanket Heating Element - Bottom Shelf	02.05.335.00	02.05.357.00	02.05.363.00
16	Blanket Heating Element - Center Shelf	02.05.336.00	02.05.358.00	02.05.364.00
17	Heating Element, Upper, Metal Sheath (Qty. 4)	R02.08.268.00	R02.08.278.00	R02.08.281.00
18	Transformer	02.17.022.00	02.17.023.00	02.17.023.00
19	Power Cord & Plug Assembly	02.18.089.00	02.18.077.00	02.18.068.00
20	Light Socket - Single with Leads (Qty. 2)	02.30.044.00	02.30.044.00	02.30.044.00
21	Light Bulb, Shatter Resistant Coating (Qty. 6) Electrical Drawing	02.30.043.00 HS2-3959	02.30.058.00 HS2-4228	02.30.058.00 HS2-4229

Shaded area reflects export models only.

PARTS SPECIFIC TO ALL GRSDS-41DBK MODELS

ITEM	DESCRIPTION	120V	220V	240V
12	Electronic Temperature Controller	02.01.049.00	R02.01.062.00	R02.01.062.00
13	Temperature Probe - Bottom Shelf	02.01.056.00	02.01.078.00	02.01.078.00
14	Temperature Probe - Top Shelf	02.01.057.00	02.01.079.00	02.01.079.00
15	Blanket Heating Element - Bottom Shelf	02.05.337.00	02.05.359.00	02.05.365.00
16	Blanket Heating Element - Center Shelf	02.05.338.00	02.05.360.00	02.05.366.00
17	Heating Element, Upper, Metal Sheath (Qty. 4)	R02.08.267.00	R02.08.277.00	R02.08.280.00
18	Transformer	02.17.022.00	02.17.023.00	02.17.023.00
19	Power Cord & Plug Assembly (Qty. 2)	R02.18.030.00	02.18.077.00	02.18.066.00
20	Light Socket - Single with Leads (Qty. 2)	02.30.044.00	02.30.044.00	02.30.044.00
21	Light Bulb, Shatter Resistant Coating (Qty. 6) Electrical Drawing	02.30.043.00 HS2-3960	02.30.058.00 HS2-4230	02.30.058.00 HS2-4231

Shaded area reflects export models only.

REPLACEMENT PARTS LIST

PARTS SPECIFIC TO ALL GRSDS-52DBK MODELS				
ITEM	DESCRIPTION	120V	220V	240V
12	Electronic Temperature Controller	02.01.049.00	R02.01.062.00	R02.01.062.00
13	Temperature Probe - Bottom Shelf	02.01.056.00	02.01.078.00	02.01.078.00
14	Temperature Probe - Top Shelf	02.01.057.00	02.01.079.00	02.01.079.00
15	Blanket Heating Element - Bottom Shelf	02.05.339.00	02.05.361.00	02.05.367.00
16	Blanket Heating Element - Center Shelf	02.05.340.00	02.05.362.00	02.05.368.00
17	Heating Element, Upper, Metal Sheath (Qty. 4)	R02.08.266.00	R02.08.276.00	R02.08.279.00
18	Transformer	02.17.022.00	02.17.023.00	02.17.023.00
19	Power Cord & Plug Assembly (Qty. 2)	R02.18.030.00	02.18.077.00	02.18.104.00
20	Light Socket - Single with Leads	---	---	---
21	Light Bulb, Shatter Resistant Coating (Qty. 8)	02.30.043.00	02.30.058.00	02.30.058.00
	Electrical Drawing	HS2-3961	HS2-4232	HS2-4233

Shaded area reflects export models only.

HATCO LIMITED WARRANTY

1. PRODUCT WARRANTY

Hatco warrants the products that it manufactures (the "Products") to be free from defects in materials and workmanship, under normal use and service, for a period of one (1) year from the date of purchase when installed and maintained in accordance with Hatco's written instructions or 18 months from the date of shipment from Hatco. Buyer must establish the product's purchase date by returning Hatco's Warranty Registration Card or by other means satisfactory to Hatco in its sole discretion.

Hatco warrants the following Product components to be free from defects in materials and workmanship from the date of purchase (subject to the foregoing conditions) for the period(s) of time and on the conditions listed below:

a) One (1) Year Parts and Labor PLUS One (1) Additional Year Parts-Only Warranty:

Toaster Elements (TQ, TRH,TK metal sheathed)
Drawer Warmer Elements (metal sheathed)
Drawer Warmer Drawer Rollers and Slides
Food Warmer Elements (metal sheathed)
Display Warmer Elements (metal sheathed air heating)
Holding Cabinet Elements (metal sheathed air heating)

b) One (1) Year Parts and Labor PLUS Four (4) Years Parts-Only Warranty on pro-rated terms that Hatco will explain at Buyer's request:

3CS and FR Tanks

c) One (1) Year Parts and Labor PLUS Nine (9) Years Parts-Only Warranty on:

Electric Booster Heater Tanks
Gas Booster Heater Tanks

THE FOREGOING WARRANTIES ARE EXCLUSIVE AND IN LIEU OF ANY OTHER WARRANTY, EXPRESSED OR IMPLIED, INCLUDING BUT NOT LIMITED TO ANY IMPLIED WARRANTY OF MERCHANTABILITY OR FITNESS FOR A PARTICULAR PURPOSE OR PATENT OR OTHER INTELLECTUAL PROPERTY RIGHT INFRINGEMENT. Without limiting the generality of the foregoing, SUCH WARRANTIES DO NOT COVER: Coated incandescent light bulbs, fluorescent lights, lamp warmer heat bulbs, glass components, Product failure in booster tank, fin tube heat exchanger, or other water heating equipment, caused by liming, sediment buildup, chemical attack or freezing, Product misuse, tampering or misapplication, improper installation or application of improper voltage.

2. LIMITATION OF REMEDIES AND DAMAGES

Hatco's liability and Buyer's exclusive remedy hereunder will be limited solely, at Hatco's option, to repair or replacement by a Hatco-authorized service agency (other than where Buyer is located outside of the United States, Canada, United Kingdom or Australia in which case Hatco's liability and Buyer's exclusive remedy hereunder will be limited solely to replacement of part under warranty) with respect to any claim made within the applicable warranty period referred to above. Hatco reserves the right to accept or reject any such claim in whole or in part. Hatco will not accept the return of any Product without prior written approval from Hatco, and all such approved returns shall be made at Buyer's sole expense. HATCO WILL NOT BE LIABLE, UNDER ANY CIRCUMSTANCES, FOR CONSEQUENTIAL OR INCIDENTAL DAMAGES, INCLUDING BUT NOT LIMITED TO LABOR COSTS OR LOST PROFITS RESULTING FROM THE USE OF OR INABILITY TO USE THE PRODUCTS OR FROM THE PRODUCTS BEING INCORPORATED IN OR BECOMING A COMPONENT OF ANY OTHER PRODUCT OR GOODS.

HATCO AUTHORIZED PARTS DISTRIBUTORS

ALABAMA

Jones McLeod Appl. Svc.
Birmingham 205-251-0159

ARIZONA

Auth. Comm. Food Equip.
Phoenix 602-234-2443
Byassee Equipment Co.
Phoenix 602-252-0402

CALIFORNIA

Industrial Electric
Commercial Parts & Service, Inc.
Huntington Beach 714-379-7100

Chapman Appl. Service
San Diego 619-298-7106

P & D Appliance
Commercial Parts & Service, Inc.
S. San Francisco 650-635-1900

COLORADO

Hawkins Commercial Appliance
Englewood 303-781-5548

FLORIDA

Whaley Foodservice Repair
Jacksonville 904-725-7800

Nass Service Co., Inc.
Orlando 407-425-2681

B.G.S.I.
Pompano Beach 954-971-0456

Comm. Appliance Service
Tampa 813-663-0313

GEORGIA

TWC Services
Smyrna 770-438-9797

Heritage Service Group
Norcross 866-388-9837

Southeastern Rest. Svc.
Norcross 770-446-6177

HAWAII

Burney's Comm. Service, Inc.
Honolulu 808-848-1466

Food Equip Parts & Service
Honolulu 808-847-4871

ILLINOIS

Parts Town
Lombard 708-865-7278

Eichenauer Elec. Service
Decatur 217-429-4229

Midwest Elec. Appl. Service
Elmhurst 630-279-8000

Cone's Repair Service
Moline 309-797-5323

INDIANA

GCS Service
Indianapolis 317-545-9655

IOWA

Electric Motor Service Co.
Davenport 319-323-1823

Goodwin Tucker Group
Des Moines 515-262-9308

KENTUCKY

Certified Service Center
Lexington 859-254-8854

Certified Service Center
Louisville 502-964-7007

LOUISIANA

Chandlers Parts & Service
Baton Rouge 225-272-6620

MARYLAND

Electric Motor Service
Baltimore 410-467-8080

GCS Service
Silver Spring 301-585-7550

MASSACHUSETTS

Ace Service Co., Inc.
Needham 781-449-4220

MICHIGAN

Commercial Kitchen Service
Bay City 517-893-4561

Bildons Appliance Service
Detroit 248-478-3320

Midwest Food Equip. Service
Grandville 616-261-2000

MINNESOTA

GCS Service
Minneapolis 612-546-4221

MISSOURI

General Parts
Kansas City 816-421-5400

Commercial Kitchen Services
St. Louis 314-890-0700

Kaemmerlen Parts & Service
St. Louis 314-535-2222

NEBRASKA

Anderson Electric
Omaha 402-341-1414

NEVADA

Burney's Commercial
Las Vegas 702-736-0006

Hi. Tech Commercial Service
N. Las Vegas 702-649-4616

NEW JERSEY

Jay Hill Repair
Fairfield 973-575-9145

Service Plus
Flanders 973-691-6300

NEW YORK

Acme American Repairs, Inc.
Brooklyn 718-456-6544

Alpro Service Co.
Brooklyn 718-386-2515

Appliance Installation
Buffalo 716-884-7425

Northern Parts Dist.
Plattsburgh 518-563-3200

J.B. Brady, Inc.
Syracuse 315-422-9271

NORTH CAROLINA

Authorized Appliance
Charlotte 704-377-4501

OHIO

Akron/Canton Comm. Svc. Inc.
Akron 330-753-6635

Certified Service Center
Cincinnati 513-772-6600

Commercial Parts and Service
Columbus 614-221-0057

Electrical Appl. Repair Service
Independence 216-459-8700

E. A. Wichman Co.
Toledo 419-385-9121

OKLAHOMA

Hagar Rest. Service, Inc.
Oklahoma City 405-235-2184

Krueger, Inc.
Oklahoma City 405-528-8883

OREGON

Ron's Service, Inc.
Portland 503-624-0890

PENNSYLVANIA

Elmer Schultz Services
Philadelphia 215-627-5401

FAST Comm. Appl. Service
Philadelphia 215-288-4800

Appliance Installation & Service
Pittsburgh 412-809-0244

K & D Service Co.
Harrisburg 717-236-9039

Electric Repair Co.
Reading 610-376-5444

RHODE ISLAND

Marshall Electric Co.
Providence 401-331-1163

SOUTH CAROLINA

Whaley Foodservice Repair
W. Columbia 803-791-4420

TENNESSEE

Camp Electric
Memphis 901-527-7543

TEXAS

GCS Service
Fort Worth 817-831-0381

Armstrong Repair Service
Houston 713-666-7100

Commercial Kitchen Repair Co.
San Antonio 210-735-2811

UTAH

La Monica's Rest. Equip. Service
Murray 801-263-3221

VIRGINIA

Daubers
Norfolk 757-855-4097

Daubers
Springfield 703-866-3600

WASHINGTON

Restaurant Appl. Service
Seattle 206-524-8200

WISCONSIN

A.S.C., Inc.
Madison 608-246-3160

A.S.C., Inc.
Milwaukee 414-543-6460

CANADA

ALBERTA

Key Food Equipment Service
Edmonton 780-438-1690

BRITISH COLUMBIA

Key Food Equipment Service
Vancouver 604-433-4484

MANITOBA

Air Rite, Inc.
Winnipeg 204-895-2300

NEW BRUNSWICK

EMR Services, Ltd.
Moncton 506-855-4228

ONTARIO

R.G. Henderson Ltd.
Toronto 416-422-5580

Choquette CKS
Ottawa 613-739-8458

QUÉBEC

Choquette CKS
Montreal 514-722-2000

Choquette CKS
Québec City 418-681-3944

HATCO CORPORATION

P.O. Box 340500, Milwaukee, WI 53234-0500 U.S.A.

(800) 558-0607 (414) 671-6350

Parts & Service Fax (800) 690-2966 Int'l. Fax (414) 671-3976

www.hatcocorp.com