

We reserve the right to change or revise specifications and product design in connection with any feature of our products. Such changes do not entitle the buyer to corresponding changes, improvements, additions or replacements for equipment previously sold or shipped.

Item	Part #	Description	Wiring Item #	Item	Part #	Description	Wiring Item #
FAN ASSEMBLIES				LAMPS AND BALLASTS			
8 Ft & 12 Ft				C.		Ballast, Electronic	(3)
A.	12W Energy Efficient	Fan Assembly	(1)	0480130		2 lamps (BA.4481676)	
	0477655	Fan Motor, Evaporator (MO.4410546)		0480131		3 lamps (BA.4481654)	
	0461805	Fan Blade (FB.4780446)		0480132		4 lamps (BA.4481677)	
6 Ft Only				D.		Fluorescent Lamp	(4)
A.	7W Energy Efficient	Fan Assembly	(1)			<i>Replace with like fixtures</i>	
	0477654	Fan Motor, Evaporator (MO.4410545)		LED FIXTURES AND POWER SUPPLY			
	0142780	Fan Blade (FB.0142780)		E.	0501213	Power Supply (EP.4481861)	(5)
THERMOSTATS				F.		LED Canopy Fixture	(6)
B.		Optional Adjustable Refrigeration Thermostat	(2)			<i>Replace with like fixtures</i>	
				G.		LED Shelf Fixture	(7)
						<i>Replace with like fixtures</i>	

Data sheet-Excel-B3XC-LEP

Note: Revision K: April 2017. Updated LED energy values. Other changes marked with a bar, circle or underline.

Engineering Plan Views

PHYSICAL DATA	
Merchandiser Drip Pipe (in.)	1 1/4
Merchandiser Liquid Line (in.)	3/8
Merchandiser Suction Line (in.)	7/8

Bulk Convertible
05-2006

Dimensions shown as inches and (mm).

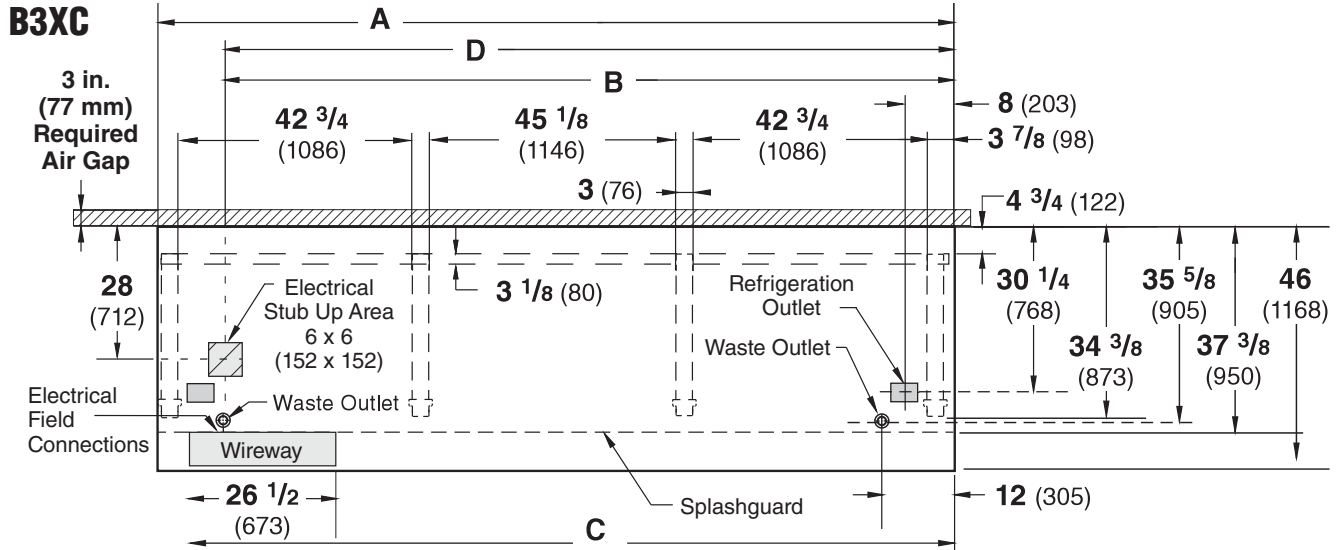

NOTE: Case-to-Case Electrical Connections are made IN FRONT OF SPLASHGUARD.

FRONT

	6 ft	8 ft	12 ft
General			
(A) Case Length (<i>without ends or partitions</i>) (Each end and insulated partition adds 1 1/2 in. (38 mm) to case line up.) Maximum O/S dimension of case back to front (includes bumper)	72 3/8 (1838)	96 3/8 (2448)	144 1/2 (3670)
Back of case to front of splashguard	46 (1168)	46 (1168)	46 (1168)
Back of case to O/S edge of front leg	37 3/8 (950)	37 3/8 (950)	37 3/8 (950)
Distance between edges of external legs and center legs	34 3/8 (873)	34 3/8 (873)	34 3/8 (873)
Distance between edges of center legs	29 1/2 (750)	42 3/4 (1085)	42 3/4 (1085)
Distance between front legs and splashguard	NA	NA	45 1/8 (1146)
	2 5/8 (66)	2 5/8 (66)	2 5/8 (66)
Electrical Service (<i>Electrical Field Wiring connection point</i>)			
(B) RH End of case to center of stub up area	60 1/4 (1530)	84 1/4 (2140)	132 3/8 (3363)
Back of case to center of stub up area	28 (712)	28 (712)	28 (712)
Length of electrical wireway	26 1/2 (673)	26 1/2 (673)	26 1/2 (673)
(C) RH End of case to LH end of wireway	66 1/8 (1680)	90 1/8 (2289)	138 1/4 (3511)
Waste Outlets (<i>One each end</i>)			
(D) RH End of case to the center of LH waste outlet	60 3/8 (1533)	84 3/8 (2143)	132 1/2 (3366)
RH End of case to the center of RH waste outlet	12 (305)	12 (305)	12 (305)
Back O/S of case to center of waste outlets	35 5/8 (905)	35 5/8 (905)	35 5/8 (905)
Schedule 40 PVC drip pipe	1 1/4 (32)	1 1/4 (32)	1 1/4 (32)
Refrigeration Outlet			
Back of case to center of refrigeration outlet	30 1/4 (768)	30 1/4 (768)	30 1/4 (768)
RH end of case to center of refrigeration outlet	8 (203)	8 (203)	8 (203)

Multi-deck, Wide Footprint, Extended Canopy Low Front,
3 Display Levels



Hussmann refrigerated merchandisers configured for sale for use in the United States meet or surpass the requirements of the DOE 2017 energy efficiency standards.

Impact *Excel* B3XC-LEP
Bulk Convertible

REFRIGERATION DATA

Note: This data is based on store temperature and humidity that does not exceed 75°F and 55% R.H.

B3XC-LEP	DAIRY/DELI/PRODUCE†§	
	UNLIT	LIT
Discharge Air °F	34	32
Evaporator °F	28	26
Unit Sizing °F	26	24

† For red meat application, lower evaporator temperature and unit sizing 3°F increase Btu 5%.

§ Average evaporator temperature shown. Use dew point for high glide refrigerants for unit sizing. Care should be taken to use the dew point in PT tables for measuring and adjusting superheat. Adjust evaporator pressure as needed to maintain discharge air temperature shown.

Btu/hr/ft — Unlit Shelves‡

B3XC-LEP	DAIRY/DELI/PRODUCE	
	Parallel	Conventional
UNLIT	1188	1268

‡ Add 10 Btu/hr/ft per shelf row for LED fixtures. Add 20 Btu/hr/ft per shelf row for fluorescent lamps.

DEFROST DATA

B3XC-LEP	
Frequency (hr)	8
Defrost Water (lb/ft/day)	7
(±15% based on case configuration and product loading.)	
OFFTIME	
Time (minutes)	30
ELECTRIC OR GAS	Not Recommended

CONVENTIONAL CONTROLS

Low Pressure Backup Control

CI/CO*

B3XC-LEP	DAIRY/DELI/PRODUCE†
Temp (°F)	19°F / 9°F

Indoor Unit Only,

Pressure Defrost Termination* 48°F

*Use a Temperature Pressure Chart to determine PSIG conversions.

† For red meat application, reduce low pressure backup control by 3°F.

Dimensions shown as inches and (mm).

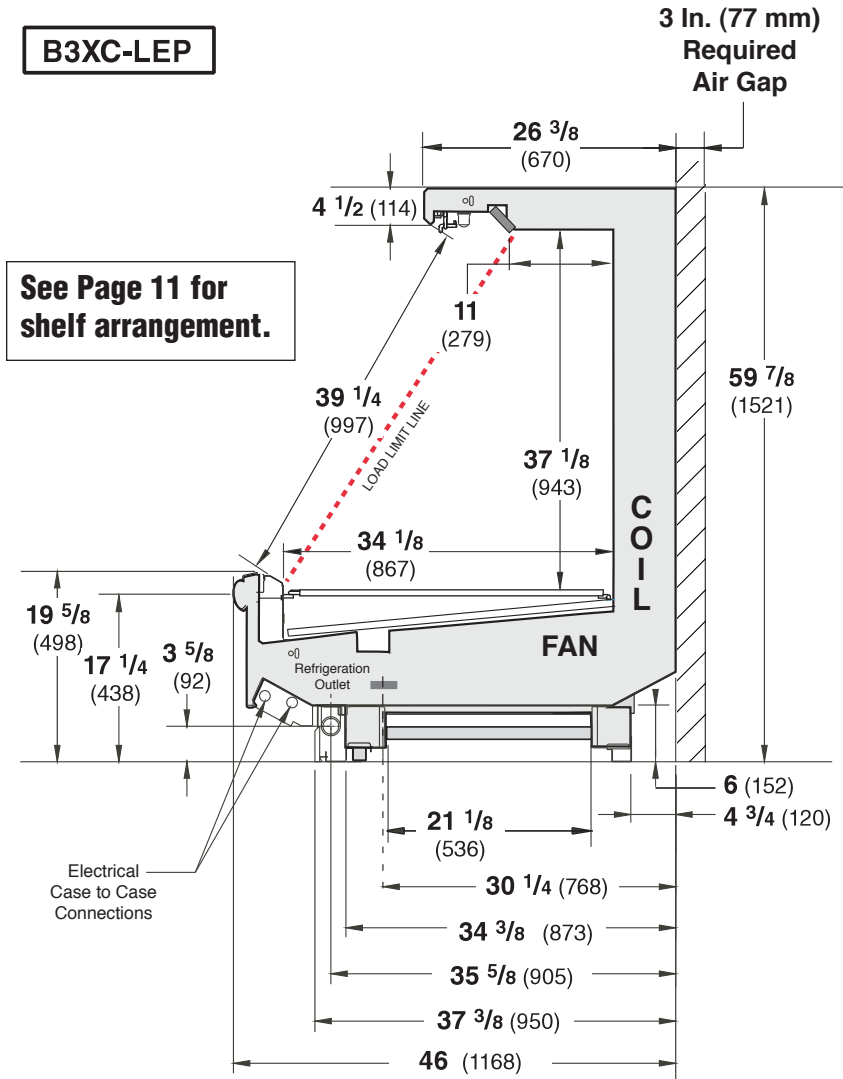

NSF Certification

This merchandiser model is manufactured to meet NSF/ANSI (National Sanitation Foundation) Standard #7 requirements for construction, materials & cleanability.

Estimated Charge**	B3XC-LEP	
6 ft	2.3 lb	37 oz 1.0 kg
8 ft	3.2 lb	51 oz 1.5 kg
12 ft	4.5 lb	72 oz 2.0 kg

**This is an average for all refrigerant types. Actual refrigerant charge may vary by approximately half a pound (8 oz/0.2 kg).

Excel B3XC-LEP

Bulk Convertible

Electrical Data

	6 ft	8 ft	12 ft		6 ft	8 ft	12 ft
Number of Fans—12W	—	2	3				
Number of Fans—7W	2	—	—				
	Amperes				Watts		
Evaporator Fan	6 ft	8 ft	12 ft		6 ft	8 ft	12 ft
120V 50/60Hz Standard Energy Efficient	0.38	0.60	0.90		28	36	54
230V 50/60Hz Standard Energy Efficient	0.20	0.30	0.45		28	36	54
230V 60Hz Export	0.50	0.66	0.99		78	100	150
230V 50Hz Export	0.56	0.76	1.14		84	114	171
Minimum Circuit Ampacity							
120V 50/60Hz Standard Energy Efficient	0.58	0.80	1.10				
230V 50/60Hz Standard Energy Efficient	0.40	0.50	0.65				
230V 60Hz Export	0.70	0.86	1.19				
230V 50Hz Export	0.76	0.96	1.34				
Maximum Over Current Protection 120V	20	20	20				
Maximum Over Current Protection 230V	15	15	15				

Standard Lighting (T-8 fluorescent)

1 Row Canopy	0.51	0.51	0.77	59	59	85
--------------	------	------	------	----	----	----

ONLY LIGHTING CONFIGURATIONS THAT ARE COMPLIANT WITH THE U.S. DEPT. OF ENERGY (DOE) 2017 REGULATION ARE AVAILABLE FOR SALE FOR USE IN THE U.S.A.

Optional Lighting (T-8 fluorescent)

1 Row Rail Light	0.51	0.51	0.77	59	59	85
1 Row of Shelves	0.51	0.51	0.77	59	59	85
2 Rows of Shelves	1.02	1.02	1.54	118	118	170
3 Rows of Shelves	1.53	1.53	2.31	177	177	255

EcoShine II Canopy

EcoShine II	0.26	0.32	0.48	31.6	38.6	58.0
EcoShine II HO	0.33	0.44	0.66	39.5	53.0	79.4

EcoShine II Rail Light — 1 Row

	0.12	0.16	0.25	14.1	19.8	29.7
--	------	------	------	------	------	------

EcoShine II Shelves

1 Row of Shelves	0.12	0.16	0.25	14.1	19.8	29.7
2 Rows of Shelves	0.23	0.33	0.49	28.2	39.5	59.3
3 Rows of Shelves	0.35	0.49	0.74	42.3	59.3	89.0

120V Lighting Circuit Total = Standard Lighting + Total Optional Lighting + Optional Shelf Lighting

120V LED Lighting Circuit Total = Canopy Lighting + Shelf Lighting + Optional Rail Lighting

230V Lighting Circuit Total = Multiply 120V Lighting Circuit Total by 0.52

Please note: some combinations of fluorescent lights on this case model may not be compliant with DOE 2017 and may not be available to order in the US and Canada. More lighting options are available with LED lights. The Hussmann Product Configurator will not allow lighting options that do not comply with the DOE 2017 standards.

Excel B3XC-LEP
Bulk Convertible

Product Data

<i>Recommended Usable Cube</i> ¹ (Cu Ft/Ft)	5.56 ft ³ /ft (0.52 m ³ /m)
<i>AHRI Total Display Area</i> ² (Sq Ft/Ft)	3.27 ft ² /ft (1.00 m ² /m)
<i>Shelf Area</i> ³ (Sq Ft/Ft)	5.70 ft ² /ft (1.74 m ² /m)

- ¹ AHRI Refrigerated Volume less shelving and other unusable space: Refrigerated Volume/Unit of Length, ft³/ft [m³/m]
- ² Computed using AHRI 1200 standard methodology: Total Display Area, ft² [m²]/Unit of Length, ft [m]
- ³ Shelf surface area is composed of bottom deck plus standard shelf complement, as shown in the Hussmann *Product Reference Guide*. The standard shelf complement for this model is (1) row of 16-inch shelf and (1) row of 18-inch shelf.

ESTIMATED SHIPPING WEIGHT⁴

Case				Solid End
	<i>6 ft</i>	<i>8 ft</i>	<i>12 ft</i>	<i>(each)</i>
lb (kg)	900 (408)	1100 (499)	1200 (544)	50 (23)

⁴ Actual weights will vary according to optional kits included.

Fan Wiring Offtime Defrost

2 & 3 Fans

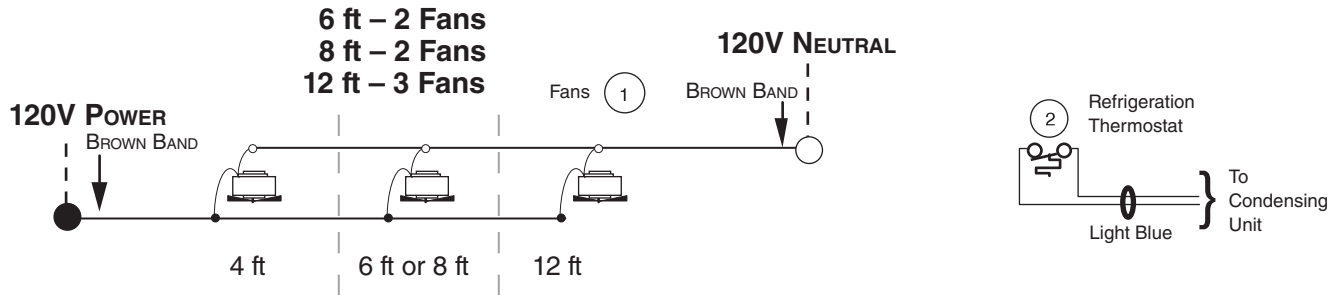

Light Circuits — Fluorescent Fixtures

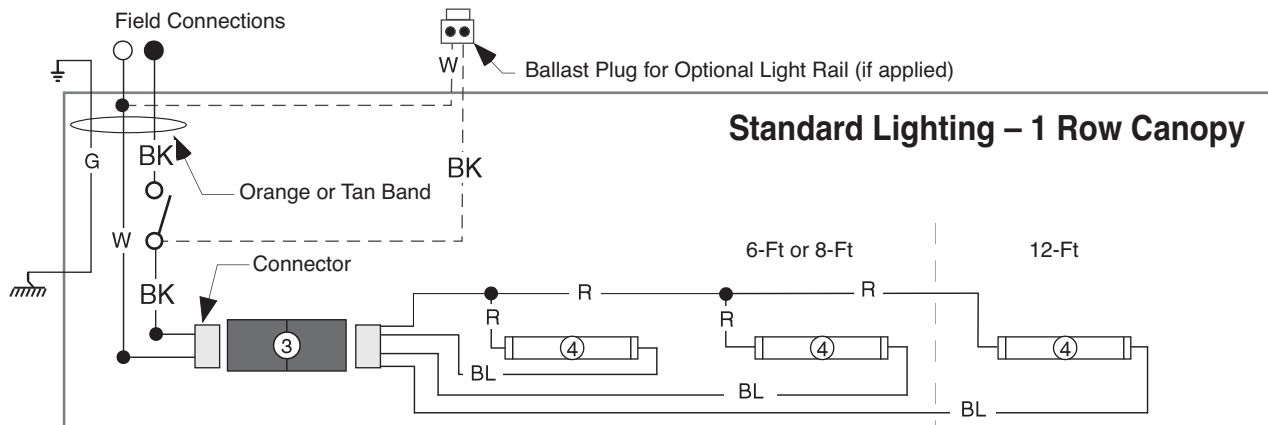

Optional Lighting – 1 Row Rail

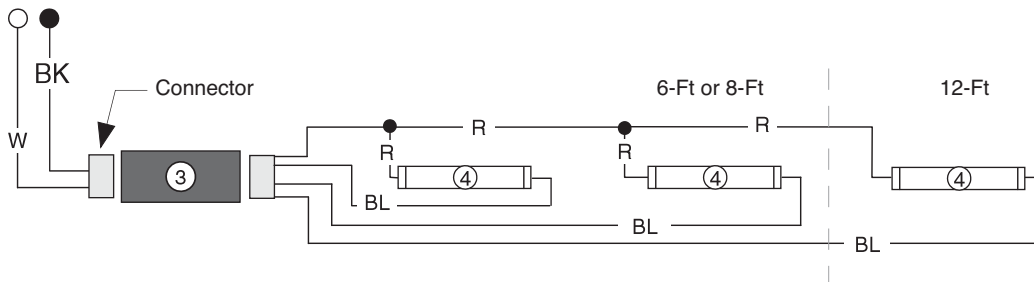

WARNING

All components must have mechanical ground, and the merchandiser must be grounded.

CIRCLED NUMBERS = PARTS LIST ITEM NUMBERS

R = Red Y = Yellow G = Green BL = Blue BK = Black W = White
 ● = 120V POWER ○ = 120V NEUTRAL ⊥ = FIELD GROUND ≡ = CASE GROUND

Optional Shelf Lighting Fluorescent Fixtures

Optional Shelf Harness and Light Circuits for Three Rows of Shelves

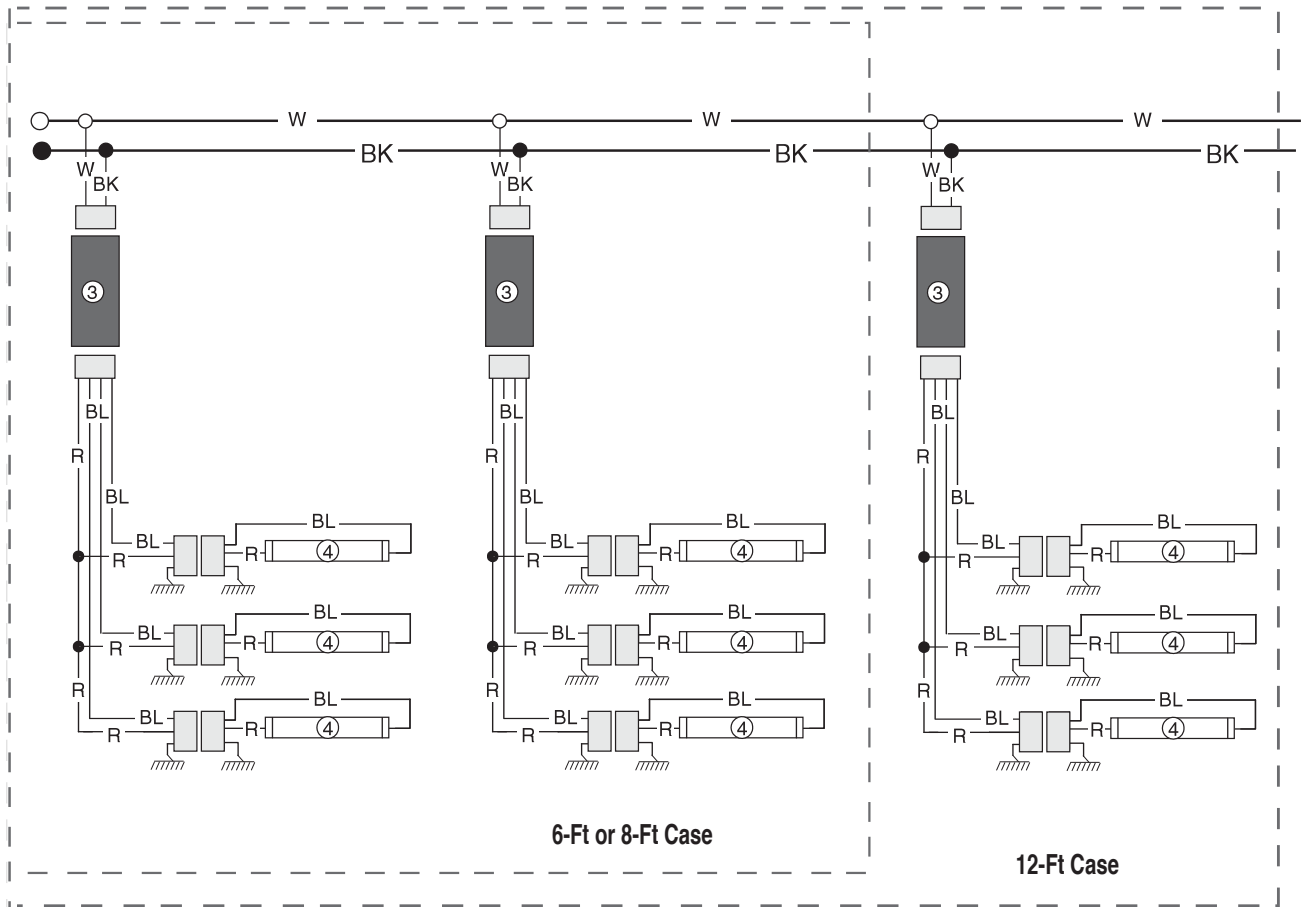

WARNING

All components must have mechanical ground, and the merchandiser must be grounded.

CIRCLED NUMBERS = PARTS LIST ITEM NUMBERS

R = Red Y = Yellow G = Green BL = Blue BK = Black W = White

● = 120V POWER ○ = 120V NEUTRAL ⚡ = FIELD GROUND ⚡ = CASE GROUND

Optional Canopy and Rail Light Circuits — LED Fixtures

EcoShine II LED Canopy Lighting – 1 Row

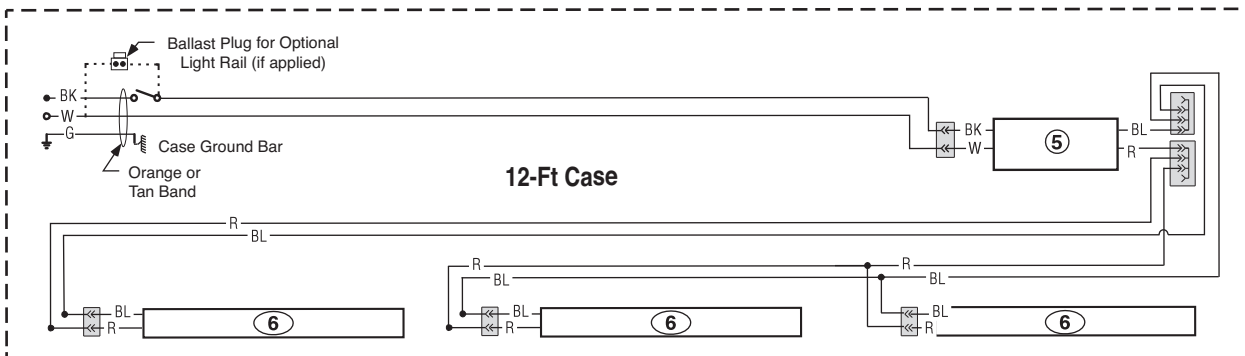
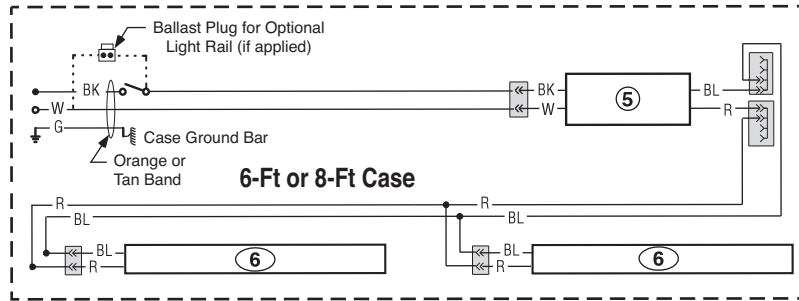

EcoShine II LED Rail Lighting – 1 Row

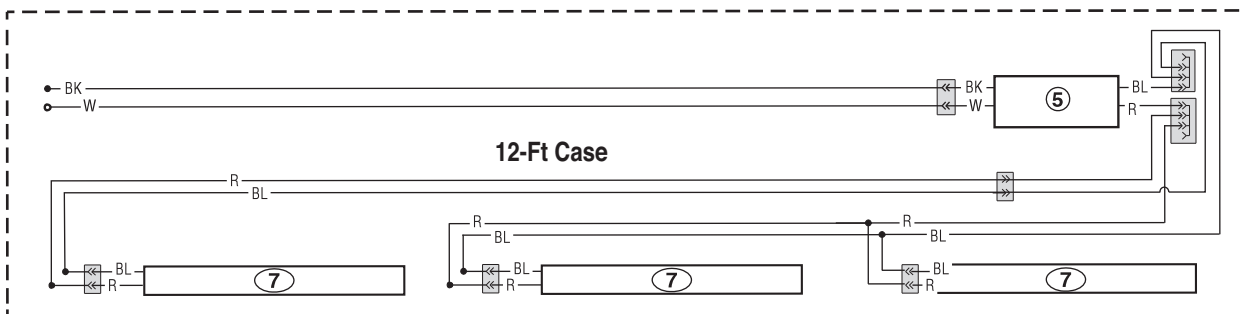
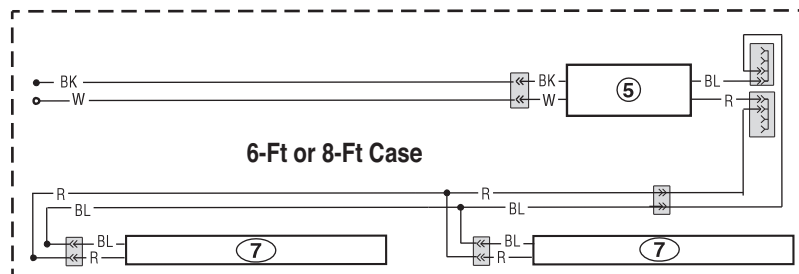

WARNING

All components must have mechanical ground, and the merchandiser must be grounded.

CIRCLED NUMBERS = PARTS LIST ITEM NUMBERS

R = Red Y = Yellow G = Green BL = Blue BK = Black W = White
 ● = 120V POWER ○ = 120V NEUTRAL ⚡ = FIELD GROUND $\overline{\text{m}}$ = CASE GROUND

Optional Shelf Lighting LED Fixtures

Optional Shelf Harness and LED Light Circuits for 2 or 3 Rows of Shelves

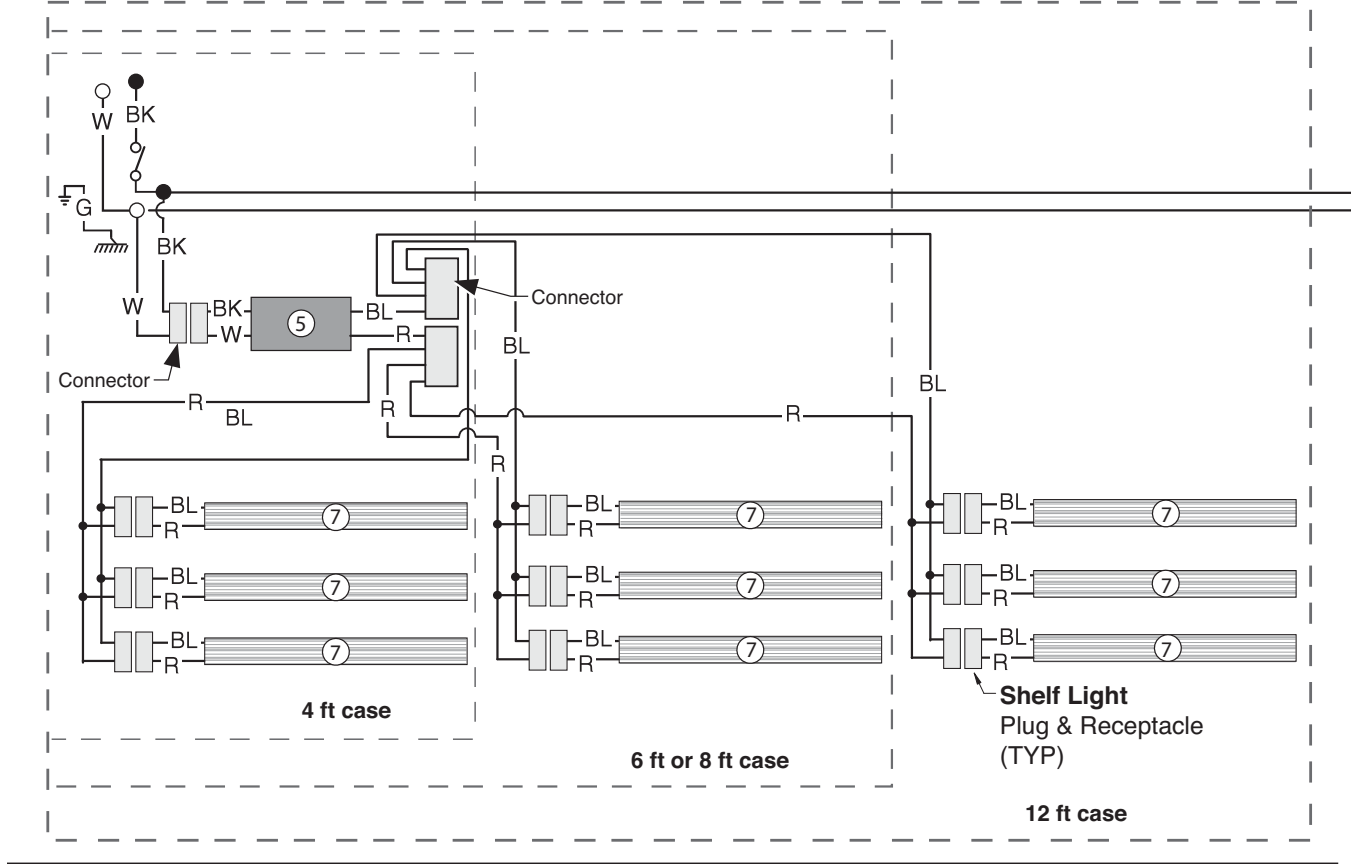

WARNING

All components must have mechanical ground, and the merchandiser must be grounded.

CIRCLED NUMBERS = PARTS LIST ITEM NUMBERS

R = Red G = Green BL = Blue BK = Black W = White
 ● = 120V POWER ○ = 120V NEUTRAL ⚡ = FIELD GROUND ≡ = CASE GROUND

Impact **Excel B3XC-LEP**
Bulk Convertible

SHELF CONFIGURATION

This case is designed for three (3) shelves.

The depth of each shelf is critical to case performance.

<p>Top Shelf Depth</p> <p>12 inches or 14 inches</p>
<p>Second Shelf Depth</p> <p>14 inches or 16 inches</p>
<p>Third Shelf Depth</p> <p>16 inches or 18 inches or 20 inches</p>

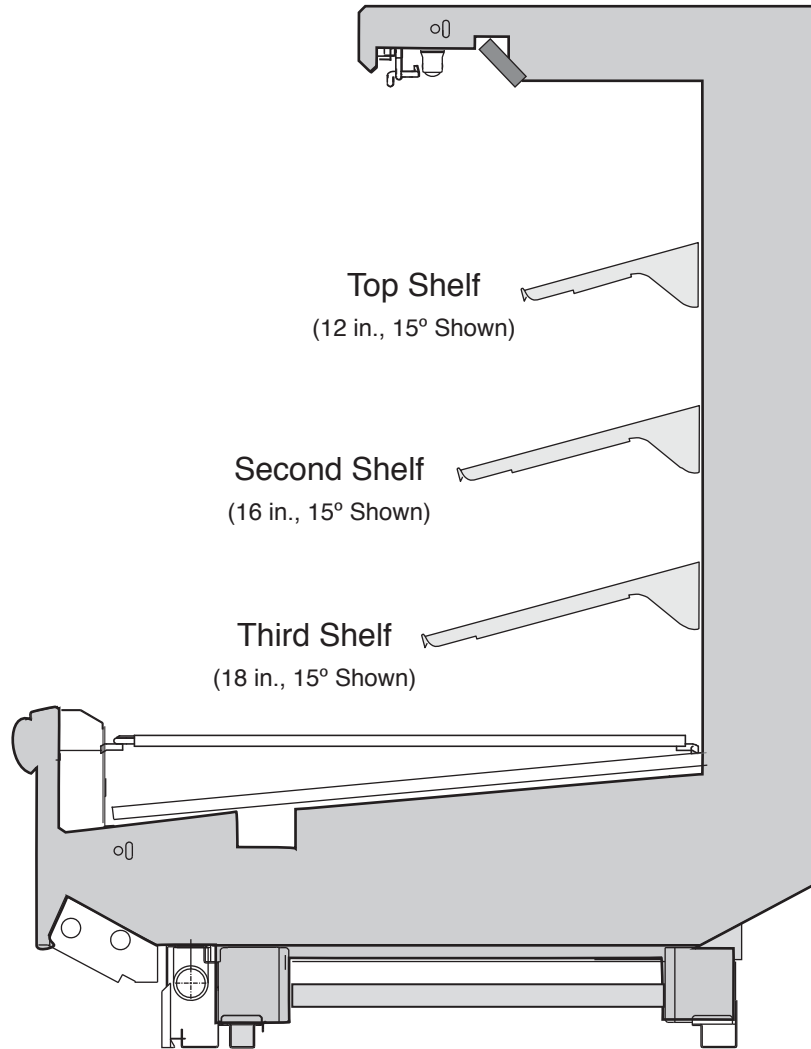

Impact *Excel* **B3XC-LEP**
Bulk Convertible

The ballast for the canopy and shelf lamps is located behind the canopy on the left-hand end (when facing case) of the merchandiser.

To access the ballast:

1. Remove screws at bottom edge of canopy and rear of light channel.
2. Lower light channel which will pivot on hinge.
3. Service or replace ballasts as required.
4. Reassemble items as they were originally installed.

NOTE: Rail lamp ballast is located in the electrical raceway.

