

**HUSSMANN**<sup>®</sup>/CHINO

**R3H, R3HTO, R3HA,**

**R3 COMBO, R3H-HF**

**HOT TOP W/SELF**

**SERVICE HEAT OR**

**REFRIGERATOR**

Installation  
& Operation  
Manual

REV. 1123

**HUSSMANN**<sup>®</sup>

R3H, R3HTO, R3HA, R3Combo, R3H-HF

**HOT SERVICE/SELF  
SERVICE/CASE WITH  
SELF SERVICE FRONT**



R3, R3H, R3P, R3HA, R3H-HF

---

INSTALLATION & OPERATION GUIDE

---

## 1. General Instructions

### **HUSSMANN®/CHINO**

A publication of HUSSMANN® Chino  
13770 Ramona Avenue • Chino, California 91710  
(909) 628-8942 FAX  
(909) 590-4910  
(800) 395-9229

[www.hussmann.com](http://www.hussmann.com)

This Booklet Contains Information on:

**R3H:** Hot Service/Refrigerated Self-Service Case

**R3HA/R3HATO:** Circulating Hot Air Case

**R3 Combo:** any combination of Hot and/or Cold Service with Self Service Refrigerated Front

#### **Shipping Damage**

All equipment should be thoroughly examined for shipping damage before and during unloading.

This equipment has been carefully inspected at our factory and the carrier has assumed responsibility for safe arrival. If damaged, either apparent or concealed, claim must be made to the carrier.

#### **Apparent Loss or Damage**

If there is an *obvious loss or damage*, it must be noted on the freight bill or express receipt and signed by the carrier's agent; otherwise, carrier may refuse claim. The carrier will supply necessary claim forms.

#### **Concealed Loss or Damage**

When loss or damage *is not apparent until after equipment is uncrated*, a claim for concealed damage is made. Make request in writing to carrier for inspection within 15 days, and retain all packaging. The carrier will supply inspection report and required claim forms.

#### **Shortages**

Check your shipment for any possible shortages of material. If a shortage should exist and is found to be the responsibility of Hussmann Chino, *notify Hussmann Chino*. If such a shortage involves the carrier, *notify the carrier immediately*, and request an inspection. Hussmann Chino will acknowledge shortages within ten days from receipt of equipment.

#### **Hussmann Chino Product Control**

The serial number and shipping date of all equipment has been recorded in Hussmann's files for warranty and replacement part purposes. All correspondence pertaining to warranty or parts ordering must include the serial number of each piece of equipment involved, in order to provide the customer with the correct parts.

**Keep this booklet with the case at all times for future reference.**

---

## 2. Table of Contents

<b>1. General Instructions.....</b>	<b>2</b>
<b>2. Table of Contents .....</b>	<b>3</b>
<b>3. Cut and Plan Views .....</b>	<b>4</b>
<b>4. Installation.....</b>	<b>5</b>
<b>5. Plumbing .....</b>	<b>10</b>
<b>6. Refrigeration .....</b>	<b>10</b>
<b>7. Electrical.....</b>	<b>12</b>
<b>8. User Information.....</b>	<b>14</b>
<b>9. Specification Sheets.....</b>	<b>22</b>
<b>10. Wiring Diagram Index.....</b>	<b>25</b>
<b>11. Wiring Diagrams .....</b>	<b>26</b>
<b>12. Troubleshooting Guide .....</b>	<b>78</b>
<b>13. Appendices .....</b>	<b>80</b>

### 3. Cut and Plan Views

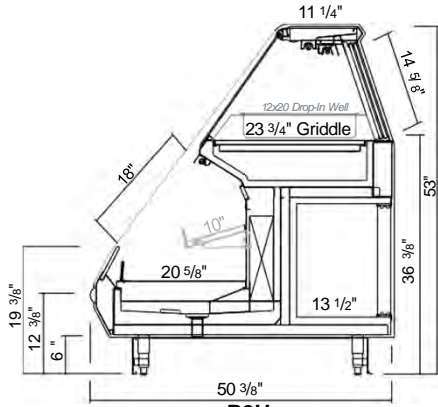

**R3H**  
Service Hot / Self Service Case  
Scale=1/2"

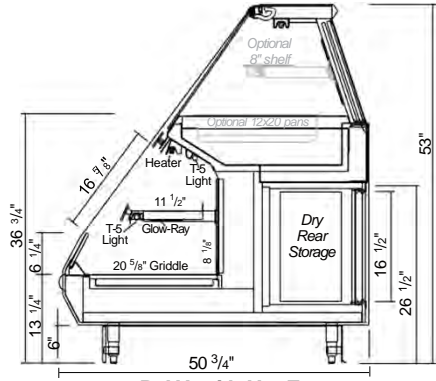

**R3HA with Hot Front**  
Hot Air Top with Hot Front Option  
and Dry Rear Storage  
Scale = 1/2"

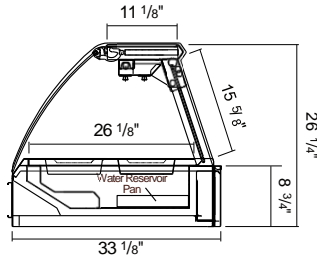

**R3HA**  
Circulated Hot Air Merchandiser

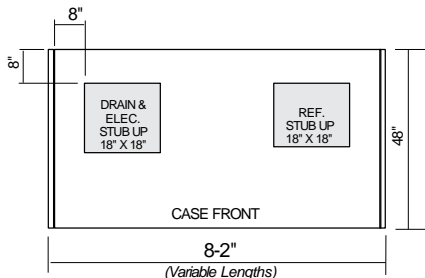

**R3**  
Plan View = 1/4"

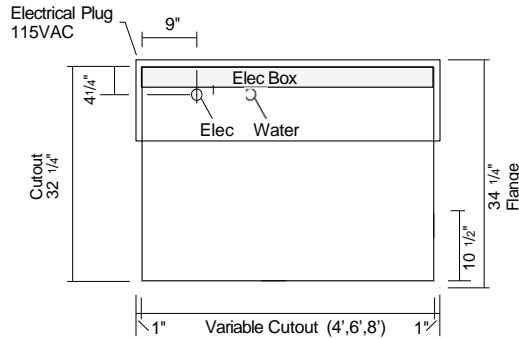

**R3TO**  
Plan view

## 4. Installation

### Location

The refrigerated merchandisers have been designed for use only in air conditioned stores where temperature and humidity are maintained at or below 75°F and 55% relative humidity. **DO NOT** allow air conditioning, electric fans, open doors, ovens, open doors or windows (etc.) to create air currents around the merchandiser, as this will impair its correct operation.

Product temperature should always be maintained at a constant and proper temperature. This means that from the time the product is received, through storage, preparation and display, the temperature of the product must be controlled to maximize life of the product.

### Uncrating the Stand

Place the fixture as close to its permanent position as possible. Remove the top of the crate. Detach the walls from each other and remove from the skid. Unbolt the case from the skid. The fixture can now be lifted off the crate skid. **Lift only at base of stand!**

### Exterior Loading

These models have **not** been structurally designed to support excessive external loading. **Do not walk on their tops;** This could cause serious personal injury and damage to the fixture.

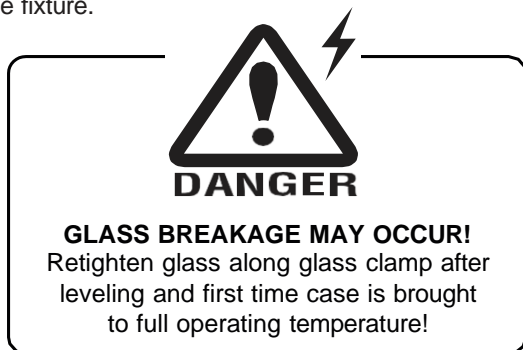

### Glass Adjustment

During shipment, the lubricant inside the cylinders may have settled. This settling may cause excessive or uneven tension on the glass - to the point of breakage. To avoid any damage, please follow these three easy steps:

1. Slowly raise and lower each glass section 6 times to a height of 6 inches.
2. Increase the height to 12 inches, and raise and lower the glass 6 more times.
3. Finally raise the glass to its full extension, and lower.

These steps should release any settled lubricant within the cylinders and prevent any stress on the front glass.

### Setting and Joining

The sectional construction of these models enable them to be joined in line to give the effect of one continuous display. A joint trim kit is supplied with each joint.

### Leveling

**IMPORTANT! IT IS IMPERATIVE THAT CASES BE LEVELED FROM FRONT TO BACK AND SIDE TO SIDE PRIOR TO JOINING. A LEVEL CASE IS NECESSARY TO INSURE PROPER OPERATION, WATER DRAINAGE, PLEXIGLASS ALIGNMENT.**

**NOTE:** A. To avoid removing concrete flooring, begin lineup leveling from the highest point of the store floor.

B. When wedges are involved in a lineup, set them first.

### Joining R3H, R3HA, R3 Combo's

All cases were leveled and joined prior to shipment to insure the closest possible fit when cases are joined in the field. When joining, use a carpenters level and shim legs accordingly. Case must be raised correctly, under legs where support is best, to prevent damage to case.

1. Check level of floor where cases are to be set. Determine the highest point of the floor; cases will be set off this point.
2. Set first case, and adjust legs over the highest part of the floor so that case is level. Prevent damage - case must be raised under leg or by use of 2x6 or 2x4 leg brace. Remove side and back leg braces after case is set.
3. Set second case as close as possible to the first case and level case **to the first** using the instructions in step one.
4. Apply masking tape 1/8" in from end of case on inside and outside rear mullion on both cases to be joined.
5. Apply liberal bead of case joint sealant (butyl) to (dotted area shown in figure) of first case. Apply heavy amount to cover entire shaded area.

**DO NOT USE PERMAGUM!**



6. Slide second case up to first case snugly. Then level second case to the first case so glass front, bumper and top are flush.
7. To compress silicone at joint, use two Jurgenson wood clamps. Make sure case is level from front to back and side to side on inside bulkheads at joint.

## Installation (Cont'd)

8. Attach sections together via a 2 bolts located in the base of the case. Secure the overhead structure by bolting the bracket, located inside behind lights.
9. Apply bead of silicone to top of bulkheads and slip on stainless steel bulkhead cap. Also apply silicone to seam between overhead light tubes.
10. Use finger to smooth silicone as thin as possible at masking tape on inside and outside of rear mullion (apply additional silicone if necessary). Remove tape applied on line #3.

### Corner Wedges

Corner wedges are attached via front and rear camlocks. Use a 7mm allen wrench to turn the locks. Do not overtighten! Join the top by using a joint bracket (included in joint kit) with 3/8" bolts.

### Scale Stand Installation Instructions



1.- Set Scale Stand to desire location



2.- Drill holes and screw in place  
(with screws provided – Hex Tek S/S  
10-16 X 1/2")



Note: Use hole pattern

### Joint Trim

After cases have been leveled and joined, and refrigeration, electrical, and wasted piping work completed, install the splashguards. Fasten along the top edge, or center, with #10 X 3/3" sheet metal screws.

**DO NOT SEAL JOINT TRIM TO FLOOR!**

### Installing R3HTO, R3HATO

All cases were tested at a level state before shipping. When joining, use a carpenters level and shim enclosing or supporting cabinet accordingly.

1. Make sure the cabinet you are installing the R3HATO on is level.
2. Wire unit according to local codes.

# Installation (Cont'd)

## Wrapping Boards Installation Instructions



Step 1: Measure 6 inches from wrapping board end.

**Note:** Line up 6 inch mark with 10 inch mark.



Step 2: Measure 10 inches from top of the case.



Step 3: Use bracket center hole to align with cross mark.

**Note:** Use pencil/marker to mark hole pattern.

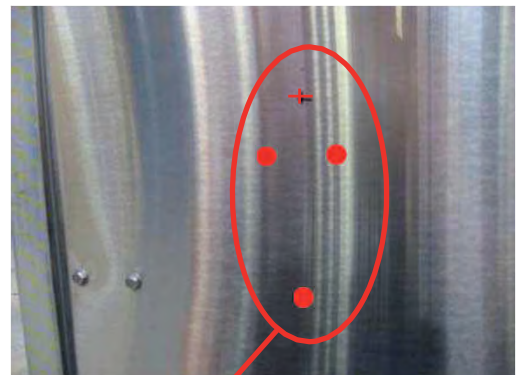

HOLE PATTERN

Step 4: Drill holes (7/32")

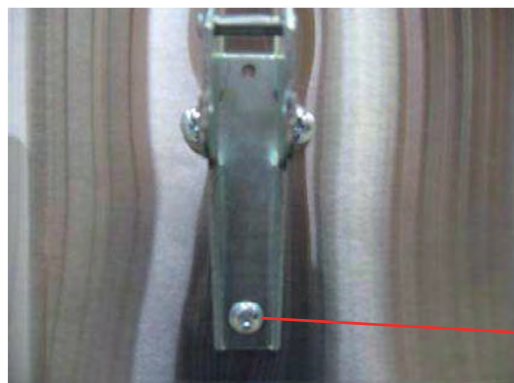

Step 5: Install bracket with screws (provided)

**Note:** Repeat Steps 1 Thru 5 for Second Bracket Installation.

# Installation (Cont'd)



Step 6: Install upper support bracket



Step 7: Mount wrap board on top of bracket using a 1/4" spacer to have a gap between rear wall and board.



Step 8: Screw bracket into wrap board (screws provided -#8 X 1 1/4")



Installation Complete

# Installation (Cont'd)

## Bumper Installation Instructions



Step 1: Make sure the aluminum channel and end caps are installed.



Step 2: Use silicone lubricant to help the bumper slide into the channel.



Step 3: Starting on one end: while inserting the bumper, push it up against the end cap to prevent the bumper from shrinking after installation (when it gets cold).



Step 4: As you insert the bumper into the channel with one hand, pull the bumper toward you with the other to open the inside lips. Slowly apply pressure by rolling the bumper into the track.

## 5. Plumbing

### Waste Outlet and P-TRAP

The waste outlet is located off the center of the case on one side allowing drip piping to be run lengthwise under the fixture. There are 2 drains in each fixture that can be easily located.

P-traps must be installed at the base of all refrigerated cases. The 1 1/2" P-TRAP and threaded adapter must be installed to prevent air leakage and insect entrance into the fixture.

### Installing Condensate Drain

Poorly or improperly installed condensate drains can seriously interfere with the operation of this refrigerator, and result in costly maintenance and product losses. Please follow the recommendations listed below when installing condensate drains to insure a proper installation:

1. Never use pipe for condensate drains smaller than the nominal diameter of the pipe or P-TRAP supplied with the case.
2. When connecting condensate drains, the P-TRAP must be used as part of the condensate drain to prevent air leakage or insect entrance. Store plumbing system floor drains should be at least 14" off the center of the case to allow use of the P-TRAP pipe section. Never use two water seals in series in any one line. Double P-TRAPS in series will cause a lock and prevent draining.
3. Always provide as much down hill slope ("fall") as possible; 1/8" per foot is the preferred minimum. PVC pipe, when used, must be supported to

maintain the 1/8" pitch and to prevent warping.

4. Avoid long runs of condensate drains. Long runs make it impossible to provide the "fall" necessary for good drainage.
5. Provide a suitable air break between the flood rim of the floor drain and outlet of condensate drain. 1" is ideal.
6. Prevent condensate drains from freezing:
  - a. Do not install condensate drains in contact with non-insulated suction lines. Suction lines should be insulated with a non absorbent insulation material such as Armstrong's Armaflex.
  - b. Where condensate drains are located in dead air spaces (between refrigerators or between a refrigerator and a wall), provide means to prevent freezing. The water seal should be insulated to prevent condensation.

### Water Supply

Tap water contains more minerals and will contribute to the mineral residue and buildup which may impair the case's performance and create undesirable cleaning issues. It is recommended that a 5 micro particle filter be used to filter the incoming water supply. Be sure to flush the water line before hooking it up to the filter to prevent blocking the filter.

## 6. Refrigeration

### Refrigerant Type

Check the serial plate on the case for information.

### Piping

The refrigerant line outlets are located under the case. Locate first the electrical box, the outlets are then on the same side of the case but at the opposite end. Insulate suction lines to prevent condensation drippage.

### Refrigeration Lines

<u>Liquid</u>	<u>Suction</u>
3/8" O.D.	5/8" O.D.

**NOTE:** The standard coil is piped at 5/8" (suction); however, the store tie-in may vary depending on the number of coils and the draw the case has. Depending on the case setup, the connecting point in the store may be 5/8", 7/8", or 1 1/8". Refer to the particular case you are hooking up.

Refrigerant lines should be sized as shown on the refrigeration legend furnished by the store.

Oil traps must be installed at the base of all suction line vertical risers on refrigerated cases.

**Pressure drop** can rob the system of capacity. To keep the pressure drop to a minimum, keep refrigerant line run as short as possible, using the minimum number of elbows. Where elbows are required, use long radius elbows only.

### Control Settings

See R3H, R3HA/R3HATO, R3 Combo technical data sheet for the appropriate settings for your merchandiser. Maintain these parameters to achieve near constant product temperatures. Product temperature should be measured first thing in the morning, after having been refrigerated overnight. Defrost times should be as follows: OFF CYCLE - Defrost times should be as directed in the R3H, R3HA/R3HATO, R3 Combo technical data sheet. The number of defrosts per day and the duration of the defrost cycle may be adjusted to meet conditions present at your location.

## Refrigeration (Cont'd)

### Access to TX Valves and Drain Lines

**Mechanical** - Remove product from end of case. Remove product racks. Remove refrigeration and drain access panels (labeled). TX valve (mechanical only) and drain are located under each access panel at end of the case.

**Electronic** - The Electronic Expansion valve master and slave cylinder(s) are located within the electrical access panel(s).

### Electronic Expansion Valve (Optional)

A wide variety of electronic expansion valves and case controllers can be utilized. Please refer to EEV and controller manufacturers information sheet. Sensors for electronic expansion valves will be installed on the coil inlet, coil outlet, and in the discharge air. (Some supermarkets require a 4th sensor in the return air). Case controllers will be located in the electrical raceway or under the case. The front Self Service Evaporator has an EPR valve installed to maintain a constant discharge temperature. It is located in the front at the right side of the case under the fan plenum near the TX valve.

### Thermostatic Expansion Valve Location

This device is located on the same side as the refrigeration stub. A Sporlan balanced port expansion valve model is furnished as standard equipment, unless otherwise specified by customer.

### Expansion Valve Adjustment

Expansion valves must be adjusted to fully feed the evaporator. Before attempting any adjustments, make

sure the evaporator is either clear or very lightly covered with frost, and that the fixture is within 10°F of its expected operating temperature.

### Measuring the Operating Superheat

1. Determine the suction pressure with an accurate pressure gauge at the evaporator outlet.
2. From a refrigerant pressure temperature chart, determine the saturation temperature at the observed suction pressure.
3. Measure the temperature of the suction gas at the thermostatic remote bulb location.
4. Subtract the saturation temperature obtained in step No. 2 from the temperature measured in step No. 3. The difference is superheat.
5. Set the superheat for 5°F - 7°F.

### Evaporator Pressure Regulator

An Evaporator Pressure Regulator is installed in the front of the self service section to maintain a constant discharge temperature. It is located at the front right side of the case, under the fan plenum near the TX Valve.

### Service Case Temperature Control

Temperature control in the upper section of the R3 with the Service Option is done by means of a thermostat and suction solenoid valve. This controls both temperature and humidity.

### T-STAT Location

T-STATS are located within the electrical raceway. Refer to diagram below.

**WARNING!**

**Do NOT apply thread sealer to ABS P-Trap.**



## 7. Electrical

R3H

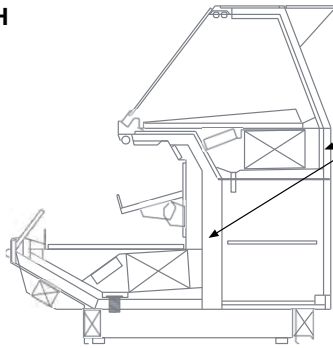

Rear Storage T-Stat and Solenoid inside Storage Area

T-Stat & Ballast (Located in the same place for hot and cold)

Front Coils controlled by EPR Valve under Deck Pan (Right side)

### Wiring Color Code

STANDARD CASE WIRE COLOR CODE CODIGO DE COLORES DE LOS ALAMBRES PARA LAS VITRINAS ESTANDAR CODE COULER POUR FILS DE BOITIER NORMALISE		
COLOR DESCRIPTION	DESCRIPCION	DESCRIPTION
GROUND	TIERRA MASA	MASSE
ANTI-SWEAT	ANTICONDENSACION	ANTI-SUINTEMENT
LIGHTS	LUCES	ECLAIRAGE
RECEPTACLES	ENCHUFES	PRISE DE COURANT
T-STAT/SOLENOID 230VAC	TERMOSTATO/SOLENOIDE (230VAC)	SOUPAPE A SOLENOID (230 VAC)
T-STAT/SOLENOID 115VAC	TERMOSTATO/SOLENOIDE (115VAC)	SOUPAPE A SOLENOID (115 VAC)
T-STAT/SOLENOID 24VAC	TERMOSTATO/SOLENOIDE (24VAC)	SOUPAPE A SOLENOID (24 VAC)
FAN MOTORS	VENTILADORES	VENTILATEUR
BLUE CONDENSING UNIT	UNIDAD DE CONDENSACION	UNITE DE CONDENSATION

**USE COPPER CONDUCTORS ONLY**  
**UTILISEZ LES CONDUCTEURS DE CUIVRE SEULEMENT**  
**UTILICE LOS CONDUCTORES DE COBRE SOLAMENTE**  
 430-01-0338 R101003

### Hot

L1	BLACK
L2	RED
L3	BLUE
NEUTRAL	WHITE

### CASE MUST BE GROUNDED

**NOTE:** Refer to label affixed to case to determine the actual configuration as checked in the "TYPE INSTALLED" boxes.

### Electrical Circuit Identification

Standard lighting for all models will be full length fluorescent lamps located within the case at the top.

The switch controlling the lights, the plug provided for digital scale, and the thermometer are located at the rear of the case mullion.

The receptacle that is provided on the exterior back of these models is intended for computerized scales with a five amp maximum load, not for large motors or other high wattage appliances. It should be wired to a dedicated circuit.

### Electrical Service Receptacles (When Applicable)

The receptacles located on the exterior of the merchandiser are intended for scales and lighted displays. They are not intended nor suitable for large motors or other external appliances.



**DANGER**

**BEFORE SERVICING  
ALWAYS DISCONNECT ELECTRICAL  
POWER AT THE MAIN DISCONNECT  
WHEN SERVICING OR REPLACING ANY  
ELECTRICAL COMPONENT.**

**This includes (but not limited to) Fans, Heaters  
Thermostats, and Lights.**

### Field Wiring and Serial Plate Amperage

Field Wiring must be sized for component amperes printed on the serial plate. Actual ampere draw may be less than specified. Field wiring from the refrigeration control panel to the merchandisers is required for refrigeration thermostats. Case amperes are listed on the wiring diagram, but always check the serial plate.

### Ballast Location

Ballasts are located within the access panel that runs the length of the rear of the case. Refer to diagram on page 14.

---

## Electrical (Cont'd)

 **CAUTION**

Fluorescent Lamps contain mercury vapor. Mercury exposure at high levels can harm the brain, heart, kidneys, lungs and immune system of people of all ages. Do not break or puncture fluorescent lamps. Dispose of, or store, all fluorescent lamps in accordance with Federal (40 CFR 273), State and local hazardous waste requirements. Refer to <http://www.epa.gov/mercury/about.htm>

**Fluorescent Lamp Disposal:** The United States Environmental Protection Agency has information regarding environmentally-safe fluorescent lamp waste management programs.

On the Net: EPA Website:

<http://www.epa.gov/osw/hazard/wastetypes/universal/lamps/recycle.htm>

## 8. User Information

### Stocking Refrigerated Sections

Improper temperature and lighting will cause serious product loss. Discoloration, dehydration and spoilage can be controlled with proper use of the equipment and handling of product. Product temperature should always be maintained at a constant and proper temperature. This means that from the time the product is received, through storage, preparation and display, the temperature of the product must be controlled to maximize life of the product. Hussmann cases were not designed to “heat up” or “cool down” product - but rather to maintain an item’s proper temperature for maximum shelf life. To achieve the protection required always:

1. Minimize processing time to avoid damaging temperature rise to the product. Product should be at proper temperature.
2. Keep the air in and around the case area free of foreign gasses and fumes or food will rapidly deteriorate.
3. Maintain the display merchandisers temperature controls as outlined in the refrigerator section of this manual.
4. Do not place any product into these refrigerators until all controls have been adjusted and they are operating at the proper temperature. Allow merchandiser to operate a minimum of 6 hours before stocking with any product.
5. When stocking, never allow the product to extend beyond the recommended load limit. **Air discharge and return air flow must be unobstructed at all times to provide proper refrigeration.**
6. Keep the service doors closed (when applicable). Refrigeration performance will be seriously affected if left open for a prolonged period of time.
7. Avoid the use of supplemental flood or spot lighting. Display light intensity has been designed for maximum visibility and product life at the factory. The use of higher output fluorescent lamps (H.O. and V.H.O.), will shorten the shelf life of the product.

### Food Handling and Hot Food Equipment

These hot tables are for short-term holding and display of precooked hot foods. They are not intended to cool or reheat food. The temperature of the food should be approximately 155°F per NSF when first put into the hot table. Pans need to be Pre-heated before placed in. These hot tables are best suited when used in a cafeteria type application where the food is held and served rapidly, within a few hours. Any attempt to use the hot table to display large amounts of food for long periods of time will result in dehydrated, overcooked and unsafe food. The quality of food will progressively worsen as the length of

time increases.

The deterioration of product quality is a function of time and temperature. All products are affected even though in a gravy or other liquid. They may appear to withstand the temperature better than “dry” foods such as fried chicken but this is not necessarily true. ALL foods will continue to be affected by prolonged exposure to elevated temperatures.

The following guidelines are provided only as a general guide for the use of this equipment. The local health agency for your area can provide specific temperature requirements.

Critical attention must be given to the heat controls for these hot tables. Both the upper and lower heat controls must be adjusted to achieve proper food temperatures. Hot foods should be held at a minimum product temperature of at least 135° F (57° C) according to 2009 FDA Food Code. However, increasing the temperature too high will also cause the food to overcook, dry out, lose its flavor, texture and color. Food held for prolonged periods at high temperatures will also lose some of their nutritional value. Different foods will require different control settings. The type of food, the quantities of food and length of time that it is to remain in the hot table must be considered when establishing control settings. Therefore, it must be the user’s responsibility to establish the correct control settings to maintain the food at the safest, tastiest and most saleable condition.

**Food temperatures can be accurately determined only through the use of food thermometers!**

#### Important Operation Tips:

- Preheat case 30 minutes before loading product using higher settings.
- Never place food directly into warmer. Always use an inset pan.
- Never pour water into a dry preheated warmer. This may damage the unit. Always pour water into warmer BEFORE preheating. Always use water in case wells, as it provides even heat and humidity.
- Too much water or too much heat will cause excessive condensation on the front glass, decreasing visibility.
- Make sure all pans are in the well units no matter the configuration.
- **Using thermometer**, check product before loading in case (150°-160°F).
- Always use warmer in wet operation when warming thick food items.
- Stir thick foods such as chili, fudge and chowders often to keep foods uniformly heated and prevent

## User Information (Cont'd)

- scorching.
- At start, set wells to "7". After loading, recheck temperature every 1/2 hour to see that unit is operating properly. Adjust the thermostat (a higher number for hotter and a lower number for cooler) to maintain product temperature of 135° F (57° C) minimum. The setting will depend on the type of product being displayed and how much there is in the well. Be sure to test product temperature with a thermometer frequently for good product maintenance.
- Food must always be placed into an inset pan over the well, never directly into the well. Using rock inserts may adversely impact product temperature.
- Food should not be stacked above the top of the pan. Food above the top of the pan will dry out rapidly.
- Food juice or gravy should be stirred frequently and any meats should be basted with the gravy. Stir and rotate foods as needed. Wipe up spills immediately for aesthetic appeal, and easier cleaning later.
- Food should be rotated periodically from the bottom to top.
- If practical, the food should be covered during slack sale periods to reduce dehydration.
- At end of the day, remove product and let case cool. Then clean with soap and water (use oven cleaner on the difficult spots). Polish and clean glass with a good glass cleaner.

### Cleaning Glass and Mirrors

Only use a soft cloth and mild glass for cleaning any glass or mirrored components. Be sure to rinse and/or dry completely.

**Never use hot water on cold glass surfaces! It may shatter and cause serious injury!** Allow glass surfaces to warm first.

### Replacing Fluorescent Lamps

Fluorescent lamps are furnished with a shatterproof protective coating. The same type of lamp with protective coating must be used if replaced.

**HUSSMANN**<sup>®</sup>

ENCAPSULITE  
SHATTERPROOF COATING - SA 10645

- Complies with FDA USDA  
& OSHA Regulations

for replacement call:  
**1-800-395-9229**

→ Turn switch off then on after replacing bulb ←

### Plexiglass and Acrylic Care

Improper cleaning not only accelerates the cleaning cycle but also degrades the quality of this surface. Normal daily buffing motions can generate static cling attracting dust to the surface. Incorrect cleaning agents or cleaning cloths can cause micro scratching of the surface, causing the plastic to haze over time.

### Cleaning

Hussmann recommends using a clean damp chamois, or a paper towel marketed as dust and abrasive free with **210<sup>®</sup> Plastic Cleaner and Polish** available by calling Sumner Labs at **1-800-542-8656**. Hard, rough cloths or paper towels will scratch the acrylic and should not be used.

### Antistatic Coatings

The **210<sup>®</sup>** has proven to be very effective in not only cleaning and polishing the Plexiglass surface, but also providing anti-static and anti-fog capabilities. This product also seals pores and provides a protective coating.

#### CAUTION

##### CLEANING PRECAUTIONS

**When cleaning:**

- Do not use high pressure water hoses
- Do not introduce water faster than waste outlet can drain
- NEVER INTRODUCE WATER ON SELF CONTAINED UNIT WITH AN EVAPORATOR PAN
- NEVER USE A CLEANING OR SANITIZING SOLUTION THAT HAS AN OIL BASE (these will dissolve the butyl sealants) or an AMMONIA BASE (this will corrode the copper components of the case)
- TO PRESERVE THE ATTRACTIVE FINISH:
- DO USE WATER AND A MILD DETERGENT FOR THE EXTERIOR ONLY
- DO NOT USE A CHLORANITED CLEANER ON ANY SURFACE
- DO NOT USE ABRASIVES OR STEEL WOOL SCOURING PADS (these will mar the finish)

### Evaporator Fans

The evaporator fans are located at the center front of these *merchandisers directly beneath the display pans*. Should fans or blades need servicing, always replace fan blades with the raised embossed side of the blade TOWARD THE MOTOR.

### Copper Coils

The copper coils used in Hussmann merchandisers may be repaired in the field. Materials are available from local refrigeration wholesalers.

Hussmann recommends using #15 Sil-Fos for repairs.

### Tips and Troubleshooting

**Before calling for service, check the following:**

1. Check electrical power supply to the equipment for connection.
2. Check fixture loading. Overstocking case will affect

## User Information (Cont'd)

its proper operation.

3. If frost is collecting on fixture and/or product, check that no outside doors or windows are open allowing moisture to enter store. These merchandisers were designed for use in stores where temperature & humidity does not exceed 75° F and 55% H.

### Controls

The controls are located at the rear of the case.

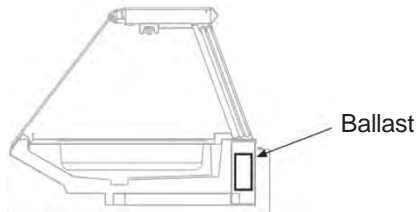

**R3HATO**  
Ballast Locations

### Stainless Steel Cleaning and Care

There are three basic things, which can break down your stainless steel's passivity layer and allow corrosion.

#### 1. Mechanical Abrasion

Mechanical Abrasion means those things that will scratch the steel's surface. Steel Pads, wire Brushes, and Scrapers are prime examples.

#### 2. Water

Water comes out of our tap in varying degrees of hardness. Depending on what part of the country you live in, you may have hard or soft water. Hard water may leave spots. Also, when heated, hard water leaves deposits behind that if left to sit, will break down the passive layer and rust your stainless steel. Other deposits from food preparation and service must be properly removed.

#### 3. Chlorides

Chlorides are found nearly everywhere. They are in water, food and table salt. One of the worst perpetrators of chlorides can come from household and industrial cleaners.

Don't Despair! Here are a few steps that can help prevent stainless steel rust.

#### 1. Use the Proper Tools

When cleaning your stainless steel products, take care to use non-abrasive tools. Soft Clothes and plastic scouring pads will NOT harm the steel's passive layer. Stainless steel pads can also be used but the scrubbing motion must be in the same direction of the manufacturer's polishing marks.

#### 2. Clean With the Polish Lines

Some stainless steels come with visible polishing lines or "grain". When visible lines are present, you should ALWAYS scrub in a motion that is parallel to them. When the grain cannot be seen, play it safe

and use a soft cloth or plastic scouring pad.

#### 3. Use Alkaline or Non-chloride Containing Cleaners

While many traditional cleaners are loaded with chlorides, the industry is providing an ever increasing choice of non-chloride cleaners. If you are not sure of your cleaner's chloride content contact your cleaner supplier. If they tell you that your present cleaner contains chlorides, ask for an alternative. Also, avoid cleaners containing quaternary salts as they also can attack stainless steel & cause pitting and rusting.

#### 4. Treat your Water

Though this is not always practical, softening hard water can do much to reduce deposits. There are certain filters that can be installed to remove distasteful and corrosive elements. If you are not sure of the proper water treatment, call a treatment specialist.

#### 5. Keep your Food Equipment Clean

Use alkaline or non-chlorinated cleaners at recommended strength. Clean frequently to avoid build-up of hard, stubborn stains. If you boil water in your stainless steel equipment, remember the single most likely cause of damage is chlorides in the water. Heating cleaners that contain chlorides has a similar effect.

#### 6. RINSE, RINSE, RINSE

If chlorinated cleaners are used you must rinse, rinse, rinse and wipe dry immediately. The sooner you wipe off standing water, especially when it contains cleaning agents, the better. After wiping the equipment down, allow it to air dry for the oxygen helps maintain the stainless steel's passivity film.

#### 7. Never Use Hydrochloric Acid (Muriatic Acid) on Stainless Steel.

#### 8. Regularly Restore/Passivate Stainless Steel.

## User Information (Cont'd)

### Hot Well/Soup Well Operating Instructions

Each hot unit has an individual heater with a separate control. These are thermostatically controlled with an indicator light showing when the heater has cycled on and is heating. The light above each control knob indicates when the well heater is heating.

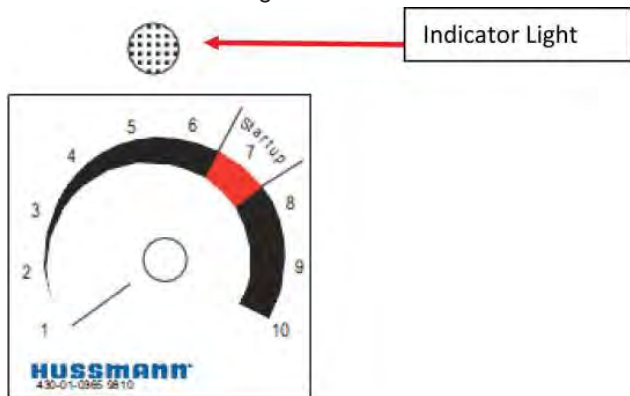

These units are for short-term holding and display of precooked hot foods. They are not intended to cool or reheat food. The temperature of the food entering the display should be approximately 155°F ± 5° when first inserted.

Any attempt to use the hot unit to display large amounts of food or soup for long periods of time will result in dehydrated, overcooked and unsafe food. The quality of the food will

progressively worsen as the length of time increases. The deterioration of product quality is a function of time and temperature. All products are affected even though in gravy or other liquid. They may appear to withstand the temperature better than “dry” foods such as fried chicken but this is not necessarily true. All foods will continue to be affected by prolonged exposure to elevated temperatures.

The following guidelines are provided only as a general guide for the use of this equipment. The local health agency for your area can provide specific temperature requirements.

Critical attention must be given to the heat controls for these hot tables/soup bars. Both the upper and lower heat controls (soup only require lower control) must be adjusted to achieve proper food temperatures. Hot foods should be held at a constant temperature of at least 140°F (60°C) (minimum FDA requirements to prevent spoiling). However, increasing the temperature too high will also cause the food to overcook, dry out, lose its flavor, texture and color. Food held for prolonged periods at high temperatures will also lose some of their nutritional value.

Different foods require different control settings. The type of food, the quantities of food and length of time that it is to remain in the hot table must be considered when establishing control settings. Therefore, it must be the user’s responsibility to establish the correct control settings to maintain the food at the safest, tastiest and saleable condition.

## User Information (Cont'd)

Startup:

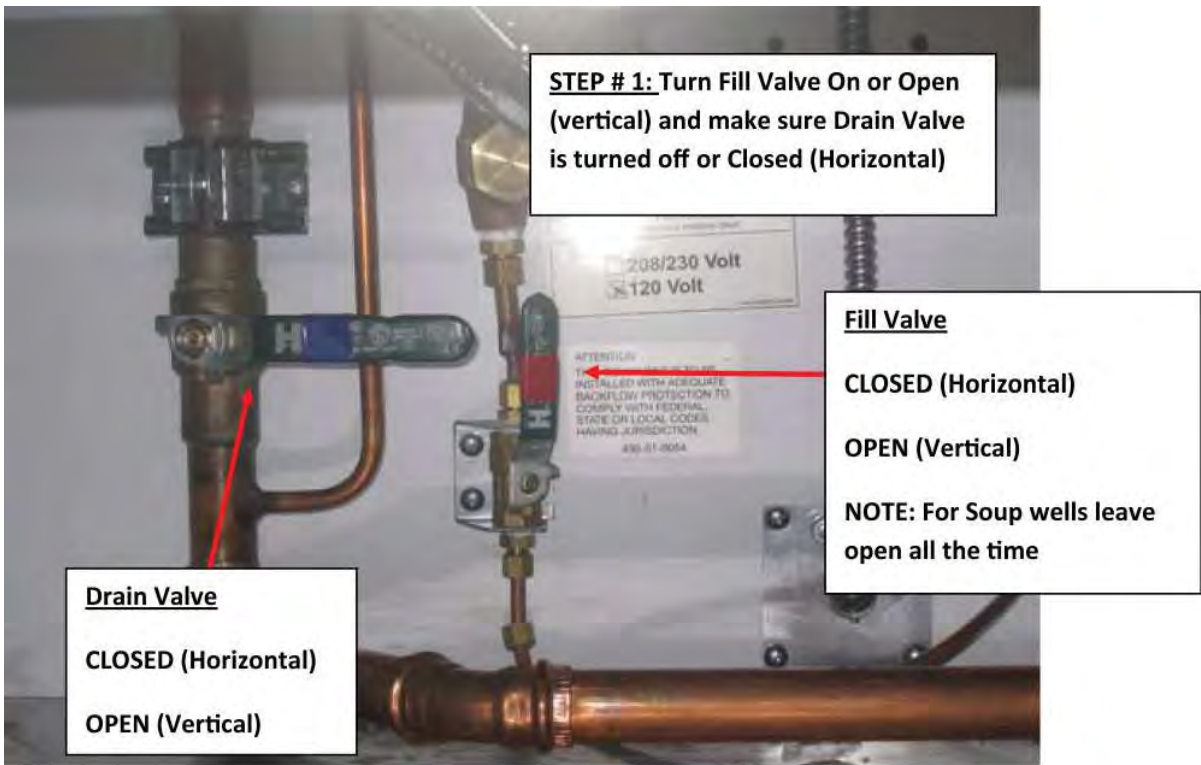

**To fill the well:**

- Turn the fill valve to open position.
- Close the drain valve.

**To drain the well:**

- Turn the fill valve to the closed position.
- Open the drain valve.

## User Information (Cont'd)

**STEP # 2:** Turn Water Fill Switch On and leave on during operation.

**STEP # 3:** After wells have filled and water has stopped, turn "ON" switch on so that red light appears on top portion of switch

**Overhead Heater**  
NOTE: Soup wells do not have overhead heaters

**Temperature Control**  
Suggested: "7"

**ON Switch**

**Water Fill Switch**  
Turn on for operation, must stay on  
NOTE: Soup wells do not have a switch there is an automatic fill

**Operation:**

- Turn the water fill switch on.
- After wells have filled turn "ON" switch on.
- Set temperature control to '7" setting. Adjust as necessary.
- Adjust overhead heater as necessary.

**Shutting down:**

- Turn "ON" switch off.
- Turn water fill switch off.
- Close fill valve.
- Open drain valve.
- Once the water is drained, close the drain valve.

---

## User Information (Cont'd)

### Overhead Heating System

Overhead heaters and fluorescent lights are located above each well to provide both top heat and illumination.

To obtain the proper food temperatures, the well heater and overhead heater must be adjusted. Maximum limits should be avoided to prevent overcooking or drying out of food.

**Note:** Soup Wells do not have overhead heaters.

### Food temperatures can be accurately determined only through the use of food thermometers!

Important Food Handling Tips:

1. Preheat case 30 minutes before loading product.
2. Never place food directly into the warmer. Always use an inset.
3. Food must be displayed in a single layer, in contact with the heat source at all times.
4. Using thermometer, check product before loading in case (150°-160°).
5. At start, set control to "7". After loading, recheck temperature every ½ hour to see that unit is operating properly. Adjust the temperature to maintain a product temperature of 140°F (60°C)

and above. The setting will depend on the type and quantity of product being displayed. Be sure to test product temperature with a thermometer frequently for good product maintenance.

6. Food should be rotated periodically.
7. At the end of the day, remove product and let case cool. Then clean with soap and water.



**CAUTION**

***Do not run hot wells without any water!***

## User Information (Cont'd)

### R3HA, R3HATO Hot Circulation Air Startup and Operation

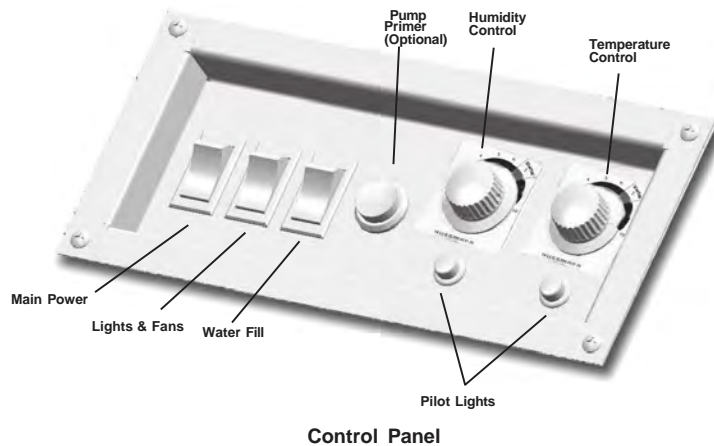

Control Panel

#### Startup:

1. Turn the **Main Power Switch ON**. (This will enable all other switches in the case).
2. Turn **Lights & Fans Switch ON**.
3. Turn **Water Fill System ON**. (For 100% DRY Heat leave water system OFF).
4. Press "**PUMP PRIME**" for **approximately 10 seconds** (optional) to self-prime the humidity system. The water reservoir (pan) **INSIDE** the case should **ALWAYS** be half full.
5. Turn **Humidity Control knob to # 7, "STARTUP"**, for maximum humidity conditions - over 7 may cause condensation on the glass. This control will continually pump water into the water reservoir (pan) **INSIDE** the case
7. Turn **Temperature Control knob to # 7, "STARTUP"**, for initial temperature settings. (This will guarantee over 140°F safe FDA temperatures).

#### Temperature Adjustment:

Adjust temperature up or down as required to maintain safe FDA Hot Food Temperatures. After adjustment, allow adequate time for change to take place. Allow 30 minutes for product to respond. Although a discharge air temperature of approximately 170°F will guarantee safe food temperatures throughout the case, use a thermometer to check food temperature periodically according to FDA guidelines.

#### Humidity Adjustment:

Adjust humidity up or down as desired for the appropriate food texture desired. More humidity for moist foods, less humidity or none for crispy foods.

Be patient, humidity adjustments to higher or lower levels are not immediate, as existing moisture (or water content) within the hot environment of the case rises or lowers at a slow pace.

# 9. Specification Sheets



**SERVICE / SELF-SERVICE**  
**HUSSMANN - R3H /CR3H (CHINA)**  
 DOE 2017 Energy Efficiency Compliant  
 Hussmann refrigerated merchandisers certified for sale for use in the United States meet or surpass the requirements of the DOE 2017 energy efficiency standards.

REVISION DATE 06/27/18

R3H Hot Service, Refrigerated Self-Service

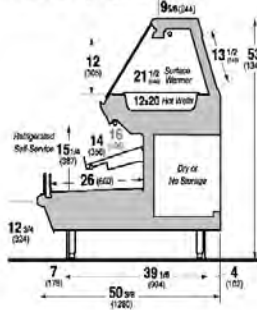

CR3H Hot Service, Refrigerated Self-Service

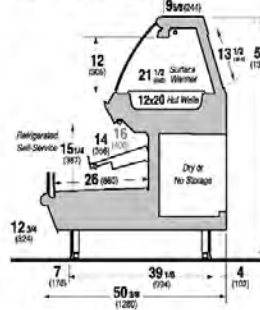

R3H / CR3H

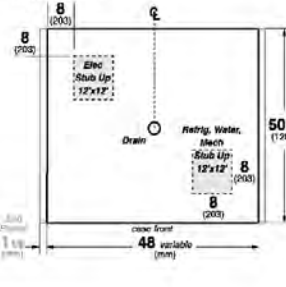

**REFRIGERATION DATA:**

CASE LENGTHS	CASE USAGE	CAPACITY FRONT (BTU/HR/FT)		TEMPERATURE (°F)			VELOCITY FRONT (FT/MIN)
		RATING CONDITION		EVAPORATOR		DISCHARGE AIR FRONT ** (°F)	
		NSF 7	AHRI 1200	NSF 7	AHRI 1200	NSF 7	
4' 5' 6' 8' 10' 12'	DELI	590	530	20	24	29-31	175-200
REAR STORAGE	DELI	110	90	20	26	28-32	600-700

CASE LENGTH S	EST. REFG. CHRG. (R404A) (LBS)	20°F GLYCOL 6" RISE			
		FRONT		REAR STORAGE	
		GPM	PSI	GPM	PSI
4'	0.5	0.9	2.1	0.2	0.0
5'	0.7	1.0	3.4	0.2	0.1
6'	0.7	1.2	4.8	0.2	0.2
8'	1.0	1.6	2.2	0.3	0.6
10'	1.4	2.0	3.9	0.4	0.7
12'	1.3	2.4	4.6	0.4	0.8

\*\*FRONT DISCHARGE AIR MEASURED INSIDE AIR CURTAIN HONEYCOMB

\*\*REFRIGERATION NOTES:

- 1) BTU'S INCLUDE CANOPY LIGHTS. ADD 10 BTU'S/SHELF/FT FOR EACH SHELF (LIGHT)
- 2) AHRI 1200 RATING POINT FOR ENERGY CONSUMPTION COMPARISON ONLY
- 3) USE DEW POINT FOR HIGH GLIDE REFRIGERANTS. CARE SHOULD BE TAKEN TO USE THE DEW POINT IN P/T TABLES FOR MEASURING AND ADJUSTING SUPERHEAT. ADJUST EVAPORATOR PRESSURE AS NEEDED TO MAINTAIN THE DISCHARGE AIR TEMPERATURE SHOWN
- 4) RATING CONDITION IS NSF TYPE I, 75°F/55% RH

**REFRIGERATION DATA CONTINUED:**

LOCATION	ELEC. THERMOSTAT		DEFROST TYPE	DEFROST TIME (MIN)	DEFROST FREQUENCY (#/DAY)	TERM. TEMP (°F) COIL ONLY	DRIP TIME	DEFROST WATER (LBS/DAY/FT)
	AIR SENSOR USAG	SETTINGS CUT IN (°F) / CUT OUT (°F)						
FRONT	DELI	31 / 28	OFF-TIME	40	3	48	N/A	2.8
REAR STORAGE	DELI	37 / 36	OFF-TIME	40	3	38	N/A	0.2

END PANEL WIDTH KEY		
# OF END PANELS	END PANEL WIDTH (IN.)	TOTAL ADDED LENGTH (IN.)
1	1.125	1.125
2	1.125	2.25

**ELECTRICAL DATA:**

**STANDARD FANS, HEATERS, LED LIGHTS (115 VOLT)**

CASE LENGTH	SELF-SERVICE SECTION EVAPORATOR FANS				REFRIGERATED REAR STORAGE EVAPORATOR FANS (OPTIONAL)		CANOPY LIGHTS LED		OPTIONAL LED SHELF LIGHTS		MAX. LED LOAD (W/ ALL OPTIONS)		ANTI-SWEAT HEATERS		CONVENIENCE OUTLETS (OPTIONAL)			
	# OF EVAP FANS	BLADE DIA. (IN.)	BLADE PITCH (")	AMPS	WATTS	AMPS	WATTS	AMPS	WATTS	AMPS	WATTS	AMPS	WATTS	AMPS	WATTS	# OUTLET S	VOLTS	AMPS
4'	2	6.75	15	0.2	16	0.3	8.8	0.1	10	0.1	10	0.2	21	0.84	97	1	115	15
5'	2	6.75	20	0.2	16	0.3	8.8	0.1	13	0.1	13	0.2	26	1.06	122	1	115	15
6'	3	6.75	15	0.4	24	0.3	8.8	0.1	15	0.1	15	0.3	31	1.28	147	1	115	15
8'	4	6.75	15	0.5	32	0.3	8.8	0.2	21	0.2	21	0.4	41	1.71	187	1	115	15
10'	4	6.75	20	0.5	32	0.3	8.8	0.2	26	0.2	26	0.5	52	2.16	247	1	115	15
12'	6	6.75	15	0.7	48	0.3	8.8	0.3	31	0.3	31	0.6	62	2.68	297	2	115	30

**HOT TOP SECTION, 60HZ 1 PHASE OR 3 PHASE AS NOTED INCLUDES LIGHTS AND FANS**

CASE LENGTH	SURFACE WARMER / HOT WELLS 208V				SURFACE WARMER / HOT WELLS 240V			
	L1	L2	L3	WATTS	L1	L2	L3	WATTS
4'	13.0	11.6	N/A	2711	15.1	13.4	N/A	3624
5'	TBD	TBD	TBD	TBD	TBD	TBD	TBD	TBD
6'	14.1	12.9	N/A	2933	16.3	14.9	N/A	3912
8'	23.8	20.9	9.4	6497	27.0	24.2	10.8	6591
10'	29.9	31.6	17.9	9535	34.5	36.5	20.7	12706
12'	25.8	27.8	25.7	8522	29.8	32.1	29.6	12678

**OPTIONAL HIGH OUTPUT LED LIGHTS (115 VOLT)**

CASE LENGTH	CANOPY LIGHTS H.O. LED		OPTIONAL SHELF		MAX. H.O. LED LOAD	
	AMPS	WATTS	AMPS	WATTS	AMPS	WATTS
4'	0.1	10	0.1	10	0.2	21
5'	N/A	N/A	N/A	N/A	N/A	N/A
6'	0.1	15	0.1	15	0.3	31
8'	0.2	21	0.2	21	0.4	41
10'	N/A	N/A	N/A	N/A	N/A	N/A
12'	0.3	31	0.3	31	0.5	62



# Specification Sheets (cont'd)



**SERVICE/ SELF-SERVICE**  
**HUSSMANN - R3HTO HOT TOP (CHINO)**

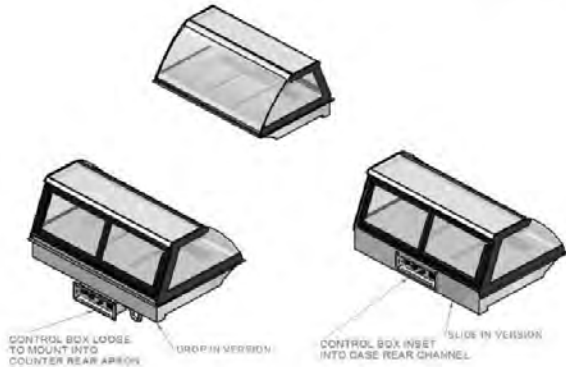
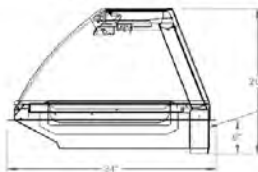
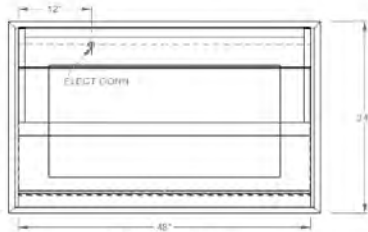

**HOT CASE DATA: 60HZ, 1-PHASE AND 3-PHASE**

CASE LENGTH	CIRCUIT#1				CIRCUIT#1				CIRCUIT#2				CIRCUIT#2			
	208V				240V				208V				240V			
	L1	L2	L3	WATTS	L1	L2	L3	WATTS	L1	L2	L3	WATTS	L1	L2	L3	WATTS
4'	12.5	11.6	N/A	2579	14.4	13.4	N/A	3432	N/A	N/A	N/A	N/A	N/A	N/A	N/A	N/A
6'	19.6	19.1	N/A	4077	22.5	22.1	N/A	5400	N/A	N/A	N/A	N/A	N/A	N/A	N/A	N/A
8'	21.4	20.9	9.4	6206	24.7	24.2	10.8	8272	N/A	N/A	N/A	N/A	N/A	N/A	N/A	N/A
12'	TBD	TBD	TBD	TBD	TBD	TBD	TBD	TBD	TBD	TBD	TBD	TBD	TBD	TBD	TBD	TBD

**END PANEL WIDTH KEY**

# OF END PANELS	END PANEL WIDTH (IN)	TOTAL ADDED LENGTH (IN)
1	1.125	1.125
2	1.125	2.25

**LEGEND**

N/A - NOT AVAILABLE  
 TBD - TO BE DETERMINED

**TOTAL WATTS**

CASE LENGTH	208/3 WATTS	240/3 WATTS
4'	2579	3432
6'	4077	5400
8'	6206	8272
12'	TBD	TBD

\*\*\* LOADS INCLUDE SINGLE ROW CANOPY LIGHTS FOR 1/3P

**LIGHTING DATA:**

T-8 LIGHTING (126 VOLT)

CASE LENGTH	# EVAP. FANS <sup>1)</sup>		TOTAL FANS		DRAIN PAN HEATERS		CANOPY LIGHTS T-8 FRONT		SHLF LIGHTS (OPTIONAL) T-8		CANOPY LIGHTS T-8 TOP (HOT SECTION)		LEDGE LIGHTS		TOTAL LIGHTS	
	1/2 AMP	3/4 AMP	AMPS	WATTS	AMPS	WATTS	AMPS	WATTS	# SHLF	AMPS	WATTS	AMPS	WATTS	AMPS	WATTS	
4'	N/A	N/A	N/A	N/A	N/A	N/A	N/A	N/A	N/A	N/A	0.26	28	N/A	N/A	0.26	28
6'	N/A	N/A	N/A	N/A	N/A	N/A	N/A	N/A	N/A	N/A	0.39	42	N/A	N/A	0.39	42
8'	N/A	N/A	N/A	N/A	N/A	N/A	N/A	N/A	N/A	N/A	0.52	56	N/A	N/A	0.52	56
12'	N/A	N/A	N/A	N/A	N/A	N/A	N/A	N/A	N/A	N/A	0.78	84	N/A	N/A	0.78	84

**ELECTRICAL DATA CONTINUED:**

CASE LENGTH	CONDENSING UNIT VOLTAGE / PHASE		H.P.	DRAIN EVAP PAN 120V		CONVENIENCE OUTLETS		
	208V	240V		AMPS	WATTS	# OUTLETS	VOLTS	AMPS
	4'	N/A	N/A	N/A	N/A	N/A	1	115
6'	N/A	N/A	N/A	N/A	N/A	1	115	15
8'	N/A	N/A	N/A	N/A	N/A	1	115	15
12'	N/A	N/A	N/A	N/A	N/A	1	115	15

**OPTIONS/NOTES:**

- GFCI receptacles are optional and furnished with case when ordered
- Metallic in-use cover shipped loose - installed in field

## 10. Electrical Wiring Diagrams

CR3H-HF-4	Top 4" dry well and 14" self front lower section	4'	W8700029
CR3H-HF-4	Top 4" dry well and 10" self front lower section	4'	W6600078
CR3H-HF-4	Top 4" dry well and 12" self front lower section	4'	W6600476
R3H-HF-5		5'	W6600024
CR3H-HF-6	4" dry upper well and 12" lower shelves	6'	W6600026
CR3H-HF-6	4" dry upper well and 10" lower shelves	6'	W8700016
CR3H-HF-8	W/14" SHELF	8'	W8700021
CR3H-HF-8	W/10" SHELF	8'	W8700022
CR3H-HF-8	W/12" SHELF	8'	W8700030
CR3H-HF-8	W/OUT SHELF	8'	W6600227
CR3-HF-12	W/10" SHELF	12'	W6600066

R3H-4-REM	HATCO SURFACE WARMER	4'	W6600152
CR3H-4-REM		4'	W8700011
R3H-6-REM		6'	W1800191
R3H-6-REM	With 4100K L.E.D. Lights	6'	W1800195
CR3H-6-REM	Upper Hot Well	6'	W8700015
R3H-8-REM	With Dry Wells	8'	W1800189
R3H-8-REM	2' Griddle 6' Hot Well Alternate	8'	W1800192
R3H-8-REM	Upper 6' Hot Well	8'	W1800196
R3-HD-8-SH-4SW-4HW-R	UPPER HOT PANS AND SOUP WELLS	8'	W6600117
CR3H-8-REM	4" WELL With 4100K L.E.D. Lights	8'	W8700020
R3H-10-REM	With L.E.D. Lights, 4" WELL	10'	W6600050
R3H-12-REM	WITH 4" DRY WELL T-5	12'	W1800199
R3H-12-REM	WITH GRIDDLE TOP LED'S	12'	W6600113
R3H-12-REM	WITH 4" DRY WELL LED'S	12'	W6600020

CIRCUIT #1

LOADING	208 V	240 V
L1	16.5	18.9
L2	15.2	17.5
L3	14.3	16.5

LIGHT CIRCUIT= 78A 84W

BOTTOM SECTION

TOP SECTION

BOTTOM SECTION

**NOTE: CASE MUST BE GROUNDED**  
**5524W @ 208VAC**  
**7330W @ 240VAC**

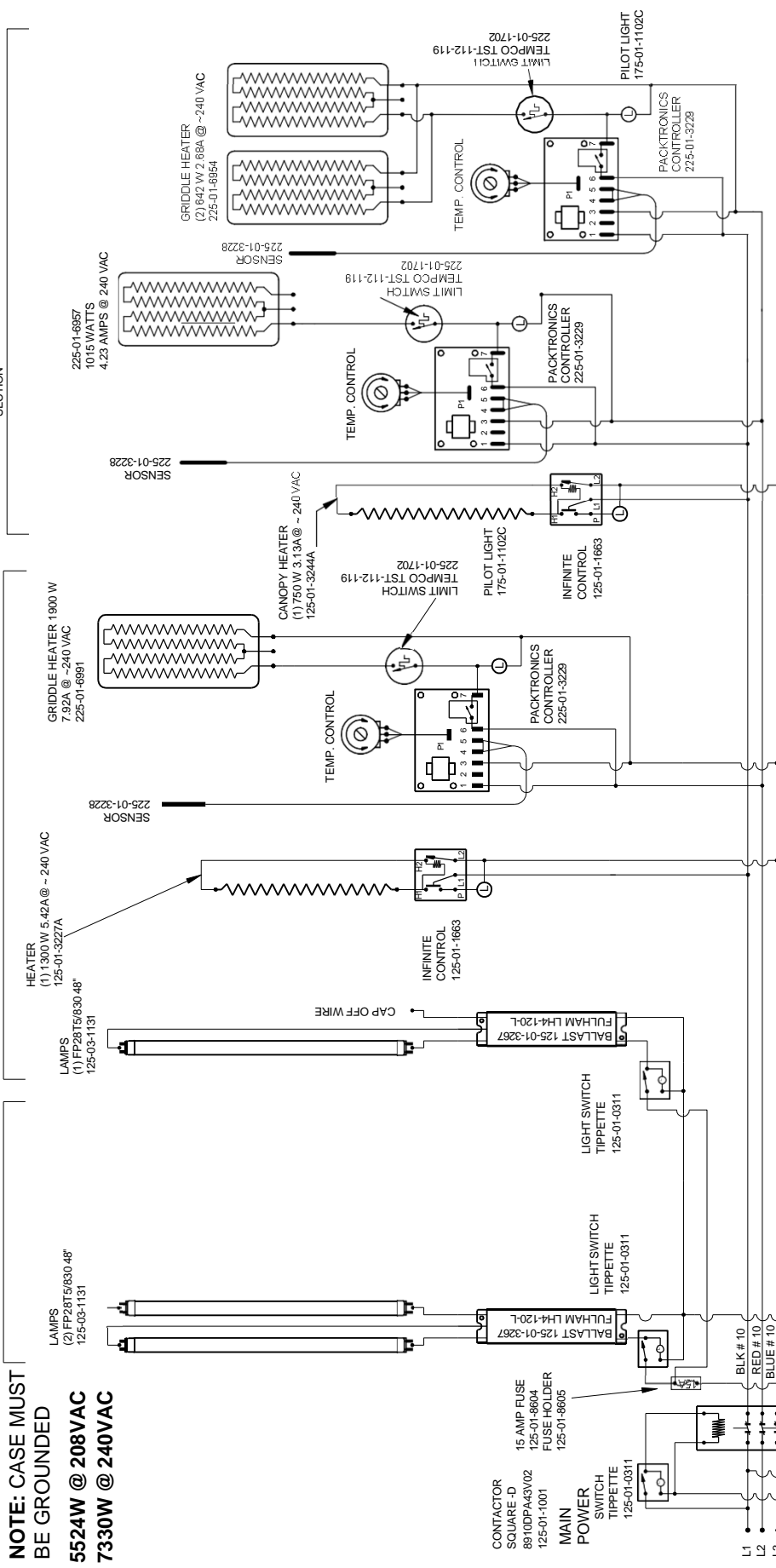

-208 / ~240 VAC - 60 HZ

**HUSSMANN**  
 Hussmann Corporation, Inc.  
 13770 Ramona Avenue  
 Chino, CA 91710 Lic.#: 644406  
 (909) 590-4910

REVISIONS:  
 # DESCRIPTION  
 A. Changed shelf control from 225-01-1700 to Packtronics  
 B. Changed shelf control from 225-01-1700 to Packtronics  
 C. ECN-CAP-001184 Added To Team Center

DATE: 11/29/11  
 BY: MG  
 1/19/18  
 CB

DRAWN BY: MATT GRAMATA  
 PROJECT TITLE: R3H  
 PRODUCTION ORDER #: 564446  
 FILE LOCATION:

DRAWING #: W8700029  
 CR3H-HF-4 with 4" dry well and lower 14" shelf  
 PAGE 1 OF 2

CIRCUIT #2

LOADING	
120 V	
L1	15.0

**NOTE: CASE MUST BE GROUNDED**

RJ-45 NETWORK JACK  
125-01-0202



NOTE FOR GFCI PROTECTION: IF MORE THAN ONE SINGLE RECEPTACLE IS USED IN CONJUNCTION WITH A GFCI DUPLEX RECEPTACLE "DOWNSTREAM" ON THE LOAD SIDE, THE SUM OF ALL RECEPTACLES SHOULD NOT BE MORE THAN 15A

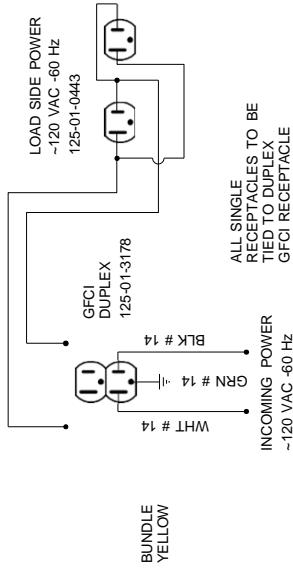

**HUSSMANN**  
Hussmann Corporation, Inc.  
13770 Ramona Avenue  
Chino, CA 91710  
(909) 590-4910 Lic.#: 644406

REVISIONS:  
# DESCRIPTION

B Changed shelf control from 225-01-1700 to Packtronics

DATE: 11/29/11  
BY: MG

CHECKED BY: MATT GRAMATA  
DATE: 4/4/11  
PRODUCTION ORDER #: 564446

PROJECT TITLE: R3H

DRAWING #: W8700029

FILE LOCATION:

CR3H-HF-4 with 4" dry well and lower 14" shelf

PAGE 2 OF 2

CIRCUIT #1

LOADING	208 V	240 V
L1	10.2	11.8
L2	18.3	21.1
L3	14.2	16.4

**NOTE: CASE MUST BE GROUNDED**  
**5128W @ 208VAC**  
**6831W @ 240VAC**

LIGHT CIRCUIT= 78A 84W

BOTTOM SECTION

TOP SECTION

BOTTOM SECTION

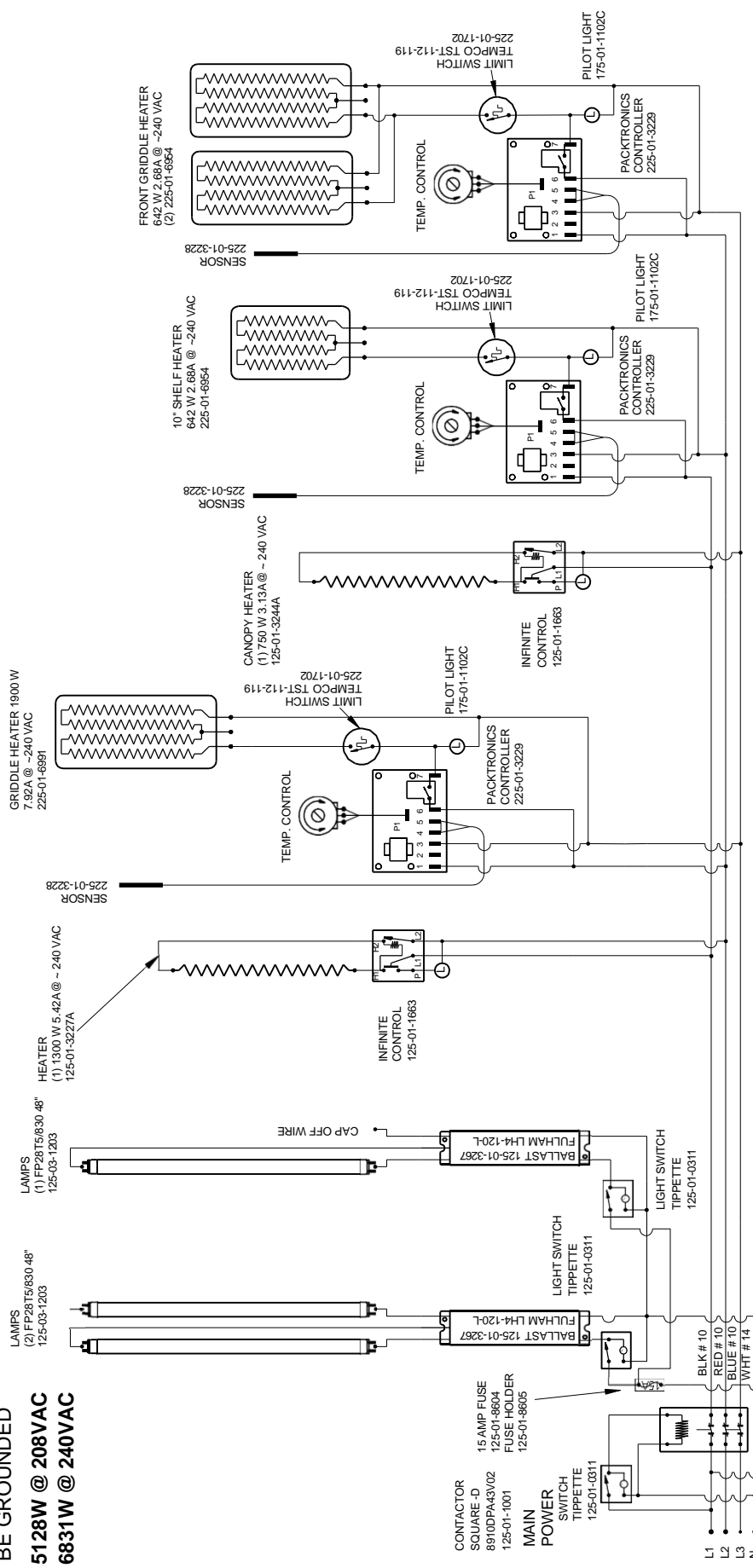

<b>HUSSMANN</b> Hussmann Corporation, Intl. 13770 Ramona Avenue Chico, CA 95710 Lic.#: 644406		DRAWING #: <b>W6600078</b>	
REVISIONS:		DRAWN BY: <b>CRAIG BOOREY</b> PROJECT TITLE: <b>R3H</b>	
#	DESCRIPTION:	DATE:	BY:
A	CN#696786	4/24/13	CB
B	CN#919095 REVISED BOTTOM SECTION HTR	8/19/14	CB
C	CN#1009293 REVISED FRONT HEATERS	10/23/15	CB
DRAWING TITLE: <b>R3H-HF-4 W/10" SHELF</b>		DRAWING ORDER #: 895502	
FILE LOCATION:		PAGE 1 OF 2	

CIRCUIT #2

LOADING	
120 V	
L1	15.0

**NOTE: CASE MUST BE GROUNDED**

RJ-45 NETWORK JACK  
125-01-0202



NOTE FOR GFCI PROTECTION: IF MORE THAN ONE SINGLE RECEPTACLE IS USED IN CONJUNCTION WITH A GFCI DUPLEX RECEPTACLE "DOWNSTREAM" ON THE LOAD SIDE, THE SUM OF ALL RECEPTACLES SHOULD NOT BE MORE THAN 15A

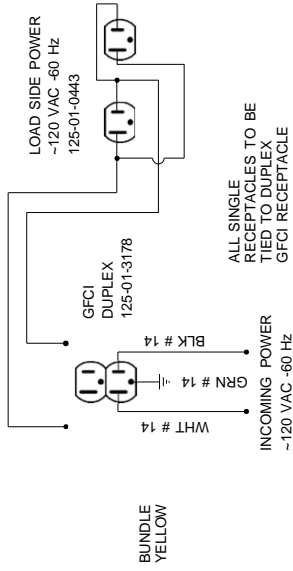

ALL SINGLE RECEPTACLES TO BE TIED TO DUPLEX GFCI RECEPTACLE

**HUSSMANN**  
Hussmann Corporation, Intl.  
13770 Ramona Avenue  
Chino, CA 91710 Lic.# 644406  
(909) 590-4910

REVISIONS:

#	DESCRIPTION
A	CN#696786
B	CN#919095 REVISED BOTTOM SECTION HTR
C	CN#1009296 REVISED FRONT HEATERS

DATE:	BY:
4/24/13	CB
8/19/14	CB
10/23/15	CB

DRAWN BY: CRAIG BOOREY  
CHECKED BY: \_\_\_\_\_  
DATE: 4/24/13  
PROJECT TITLE: R3H  
PRODUCTION ORDER #: 895502  
DRAWING TITLE:  
FILE LOCATION:  
R3H-HF-4 W/10" SHELF

DRAWING #: W6600078

REVISION HISTORY			
REV	EN	DATE	DESCRIPTION
1	A	2018/10/08	RELEASED TO PRODUCTION
REV BY	CHKD BY	APPR BY	CE
CB	CB	CB	CB

CIRCUIT #1

LOADING	
208 V	240 V
L1	11.4
L2	19.4
L3	14.2
	16.4

5404W @ 208VAC  
7191W @ 240VAC

LIGHT CIRCUIT = 7BA 84W

TOP SECTION

BOTTOM SECTION

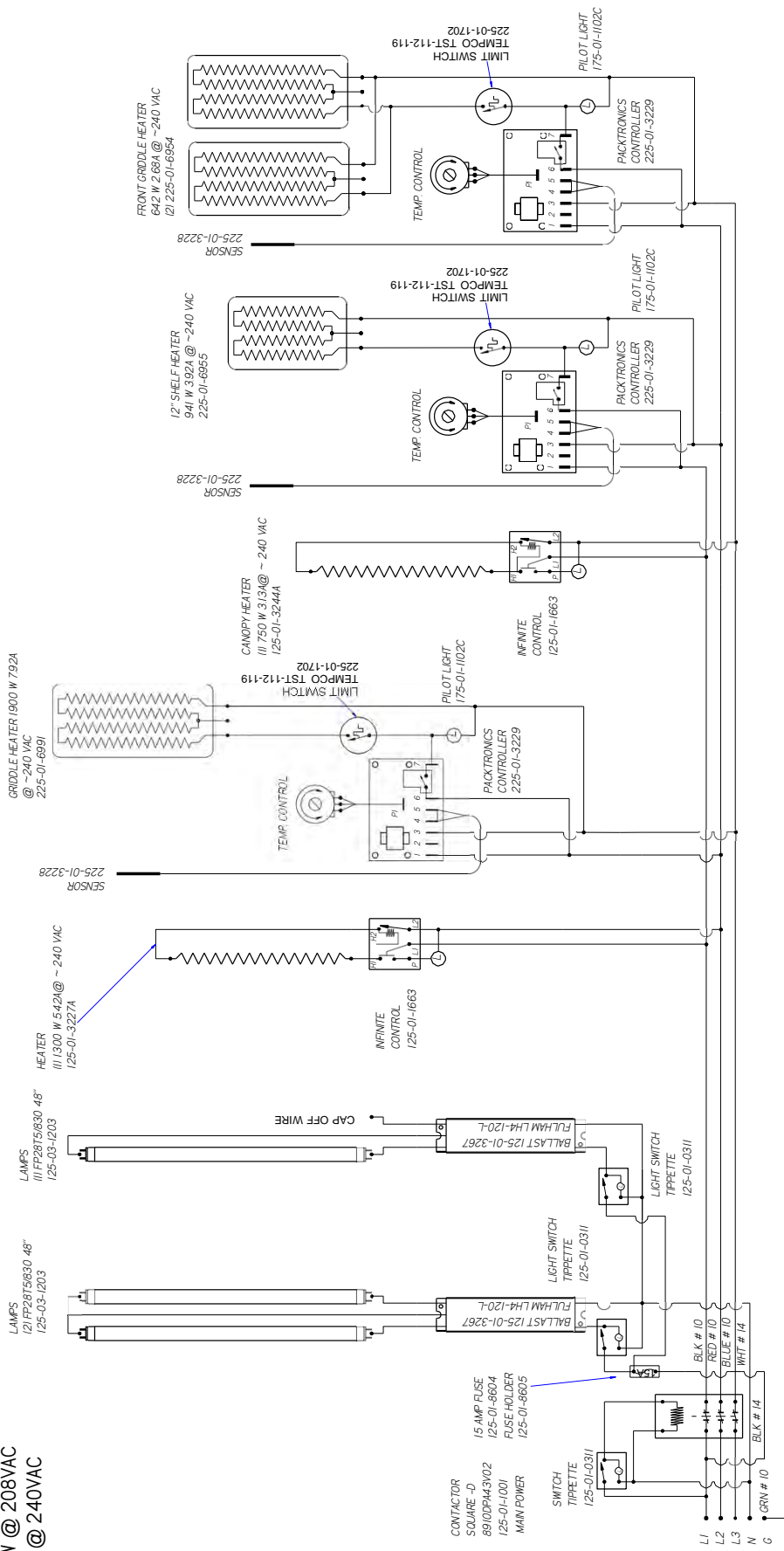

MATERIAL - N/A

DATE DRAWN - 11-6-18

DRAWN BY - CRAIG BOOREY

REVIEWED BY - CRAIG BOOREY

APPROVED BY - CRAIG BOOREY

UNLESS OTHERWISE SPECIFIED DIMENSIONS ARE IN INCHES

TOLERANCES ARE:

DECIMALS .XX +0.3, .XXX

±0.0

**HUSSMANN**  
DIAGRAM-R3H-HF-  
4 W/12" SHELF

ECON-CAP-0014945

REF -

SHEET 1 OF 2

THIRD

ANGLES ± 2°

PROJECTION

W6600476

A

NOTES:  
CASE MUST BE GROUNDED  
WHEN PASSING WIRES THROUGH METAL HOLES A GROMMET MUST BE USED

CIRCUIT #2

LOADING	
120V	
L1	150

RJ-45 NETWORK JACK  
125-01-0202



NOTE FOR GFCI PROTECTION IF MORE THAN ONE SINGLE RECEPTACLE IS USED IN CONJUNCTION WITH A GFCI DUPLEX RECEPTACLE "DOWNSTREAM" ON THE LOAD SIDE, THE SUM OF ALL RECEPTACLES SHOULD NOT BE MORE THAN 15A

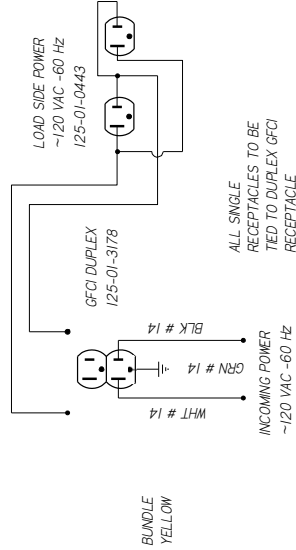

NOTES:  
CASE MUST BE GROUNDED  
WHEN PASSING WIRES THROUGH METAL HOLES A GROMMET MUST BE USED

REVISION HISTORY			
REV	EN	DATE	APP BY
1	ECN-CAP-006945	2018/10/08	CB
RELEASED TO PRODUCTION			
			CB
			CB

**HUSSMANN**  
DIAGRAM-R3H-HF--  
4 W/12" SHELF

MATERIAL - NA  
DATE DRAWN -11-6-18  
DRAWN BY - CRAIG BOOREY  
REVIEWED BY - CRAIG BOOREY  
UNLESS OTHERWISE SPECIFIED DIMENSIONS ARE IN INCHES  
TOLERANCES ARE:  
DECIMALS .XX +0.3 .XXX  
±0.0

ECN-CAP-0074945  
REF -  
SHEET 2 OF 2  
THIRD ANGL  
E PROJECTION

ANGLES ± 2°

W6600476 | A

CIRCUIT #1

LOADING	208 V	240 V
L1	13.7	15.8
L2	19.8	22.9
L3	19.9	23.0

**NOTE: CASE MUST BE GROUNDED**  
**6413W @ 208VAC**  
**8549W @ 240VAC**

LIGHT CIRCUIT= .91A 98W

BOTTOM SECTION

TOP SECTION

BOTTOM SECTION

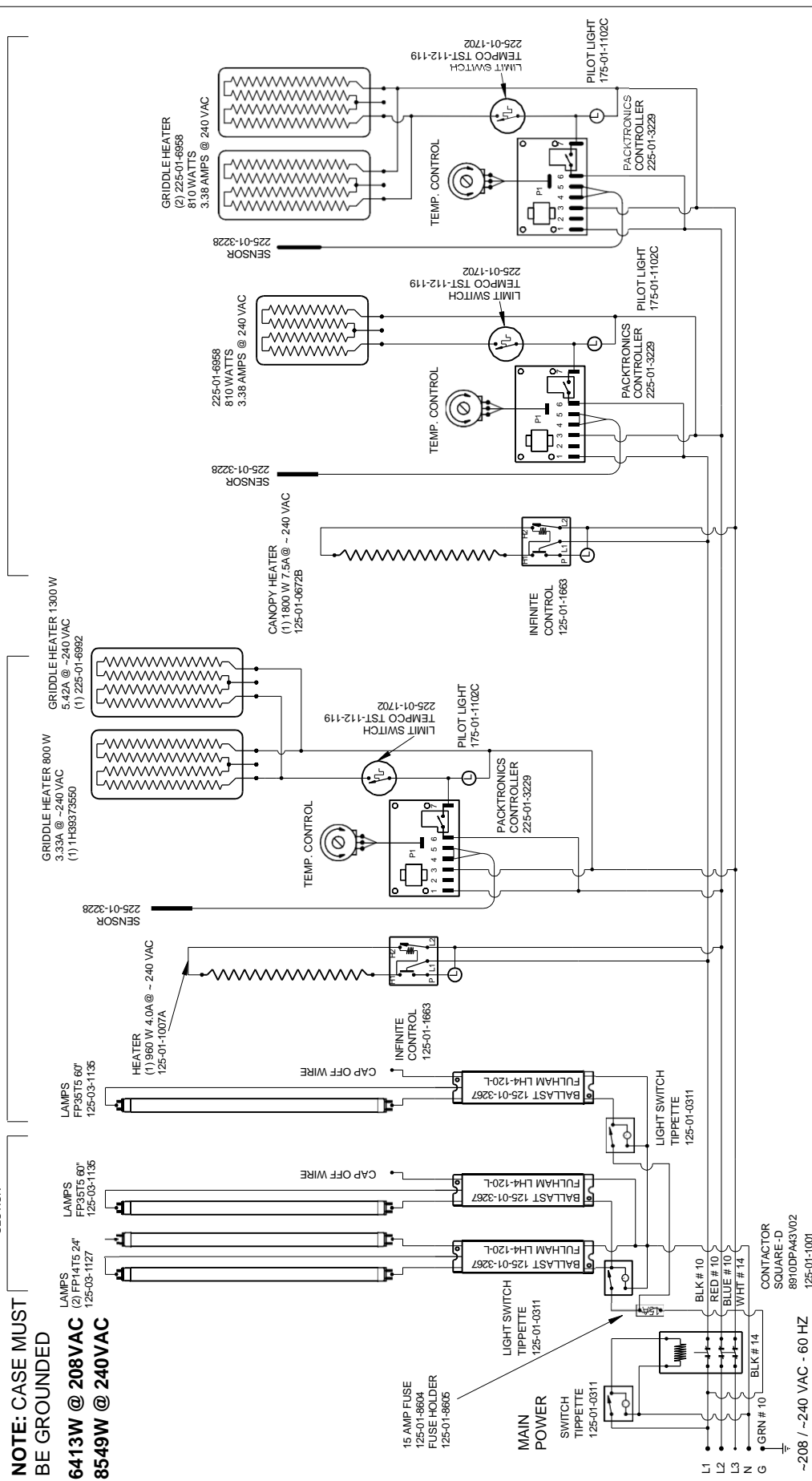

**HUSSELMANN**  
 Husseilmann Corporation, Intl.  
 13770 Ramona Avenue  
 Chino, CA 91710 Lic.# 644406

REVISIONS:  
 # DESCRIPTION: A CN#608549, NEW RELEASE C CN#634531, CHGD UPPER, LOWER GRIDDLE PADS

DRAWN BY: CRAIG BOOREY PROJECT TITLE: R3H  
 CHECKED BY: DATE: 3/23/12  
 BY: CB PRODUCTION ORDER #: 565094  
 DATE: 03/23/12  
 CB 04/24/12  
 CB FILE LOCATION: R3H-HF-5

DRAWING #: W6600024

PAGE 1 OF 2

CIRCUIT #2

LOADING
120 V
L1 15.0

**NOTE: CASE MUST BE GROUNDED**

RJ-45 NETWORK JACK  
125-01-0202



NOTE FOR GFCI PROTECTION: IF MORE THAN ONE SINGLE RECEPTACLE IS USED IN CONJUNCTION WITH A GFCI DUPLEX RECEPTACLE "DOWNSTREAM" ON THE LOAD SIDE, THE SUM OF ALL RECEPTACLES SHOULD NOT BE MORE THAN 15A

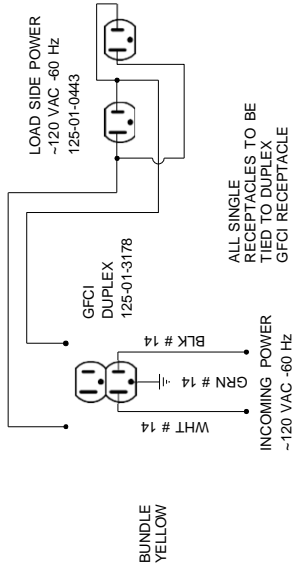

**HUSSMANN**  
Hussmann Corporation, Intl.  
13770 Ramona Avenue  
Chino, CA 91710  
(909) 590-4910 Lic.# 644406

REVISIONS:

#	DESCRIPTION
A	CN#608549, NEW RELEASE
C	CN#634531, CHGD UPPER, LOWER GRIDDLE PADS

DRAWN BY: CRAIG BOOREY	PROJECT TITLE: R3H
CHECKED BY: _____	DATE: 3/23/12
BY: CB	PRODUCTION ORDER #: 565094
DATE: 03/23/12	DRAWING TITLE: R3H-HF-5
04/24/12	FILE LOCATION: _____

DRAWING #: W6600024



CIRCUIT #1	
LOADING	
208 V	240 V
L1	23.2
L2	23.5
L3	22.4

**NOTE: CASE MUST BE GROUNDED**  
**8298W @ 208VAC**  
**11029W @ 240VAC**

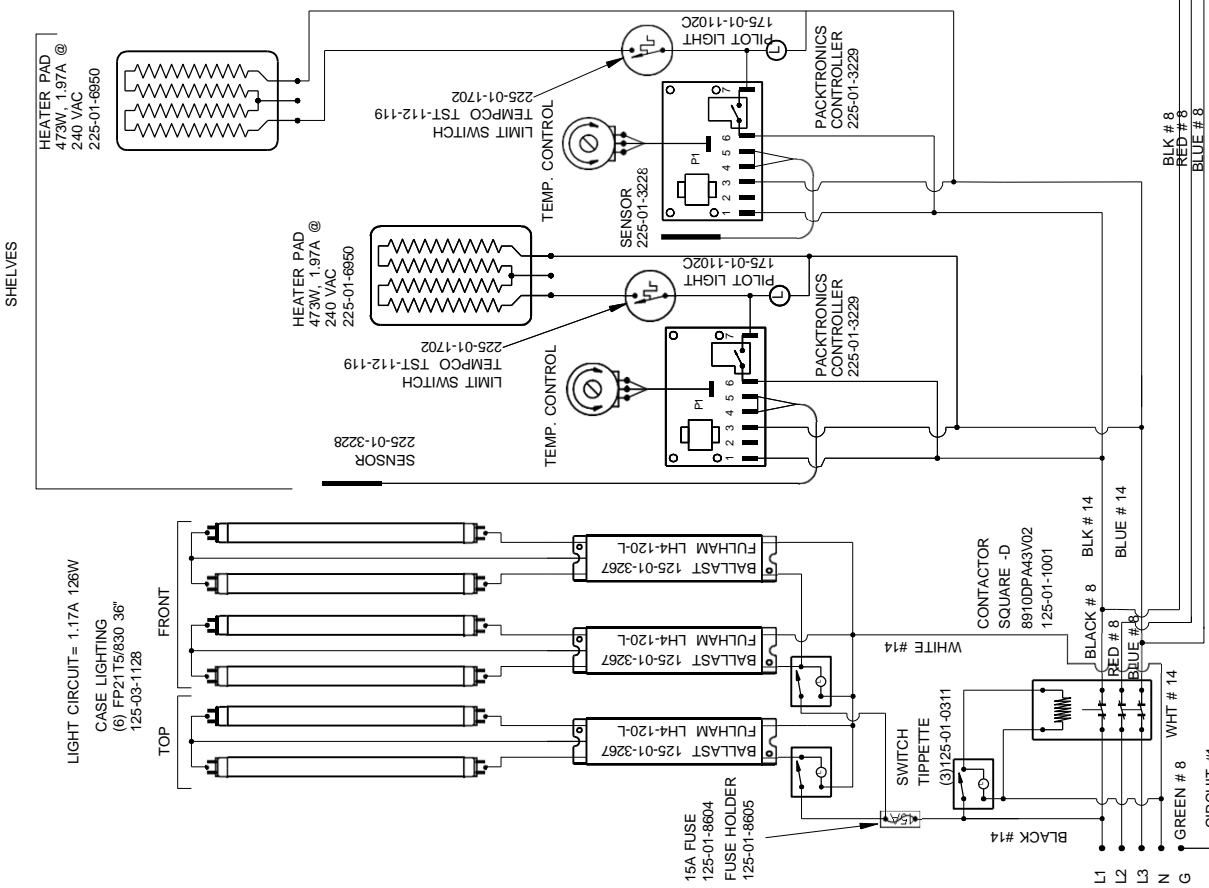
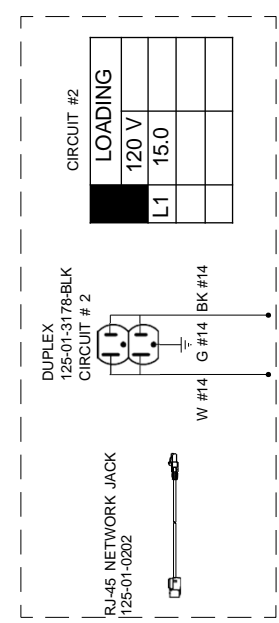

**REVISIONS:**

#	DESCRIPTION:	DATE:	BY:
F	Changes made to upper hot wells per lab	4/13/10	JR
G	ADDED SENSOR, T-STAT & PILOT LIGHT TO SHELF	7/18/11	CB
H	SEPERATED REV-G INTO (2) SETS OF CONTROLS	7/20/11	CB

**PROJECT TITLE:** CR3H-HF-6 WITH 10" FRONT SHELF

**DRAWING #:** W8700016

**DRAWN BY:** JESSE RIOS

**CHECKED BY:** [ ]

**DATE:** 8/29/07

**PRODUCTION ORDER #:** 964699

**FILE LOCATION:**

**DATE:** 4/13/10

**BY:** JR

**DATE:** 7/18/11

**BY:** CB

**DATE:** 7/20/11

**BY:** CB

**HUSSMANN**  
 Hussmann Corporation, Intl.  
 13770 Ramona Avenue  
 Chino, CA 91710  
 (909) 590-4910 Lic.# 644406

CIRCUIT #1

LOADING	208 V / 240 V
L1	15.1 / 17.4
L2	15.8 / 18.2
L3	14.8 / 17.0

**NOTE: CASE MUST BE GROUNDED**

**7288W @ 240VAC**  
**5487W @ 208VAC**

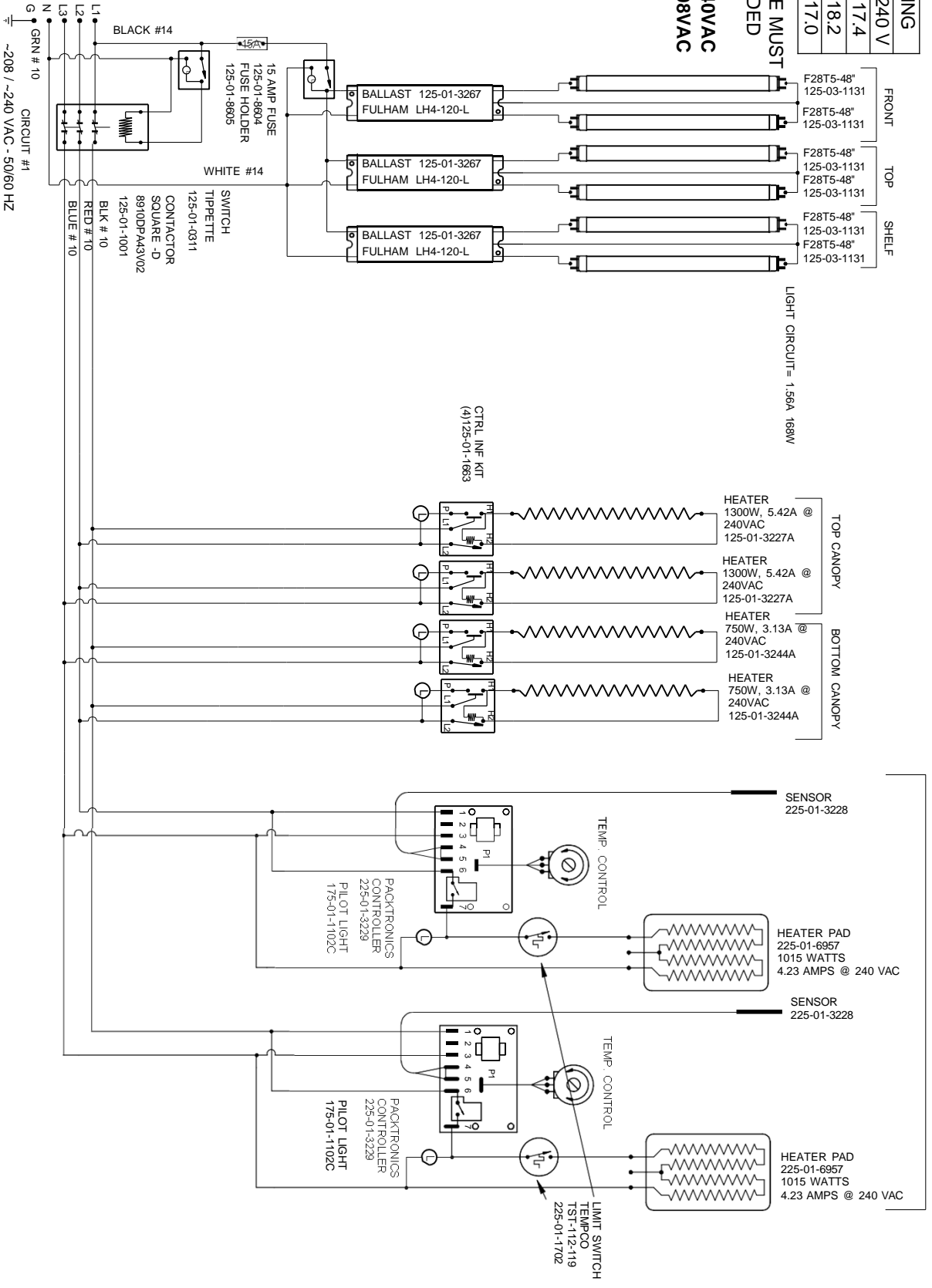

REVISIONS:		DRAWN BY: JESSE RIOS		PROJECT TITLE: CR3		DRAWING #: W8700021	
#:	DESCRIPTION:	DATE:	BY:	CHECKED BY:	DATE:		
E	Added Sensor, I-stat & Pilot Light to each shelf	8/11/11	CB	PRODUCTION ORDER #:	621533		
F	Changed the Heater Pads, Balanced Loads	1/26/12	CB	FILE LOCATION:			
G	ECN-CAI-0003963 Changed Relay	10/17/16	CB				

Hussmann Corporation, Intl.  
 13770 Ramona Avenue  
 Chino, CA 91710  
 (909) 590-4910 Lic.#: 644406

DRAWING TITLE: CR3H-HF-8 W/14" SHELF  
 PAGE 1 OF 3

CIRCUIT #2

LOADING	208 V	240 V
L1	20.8	24.1
L2	20.8	24.1
L3	9.3	10.7

**NOTE: CASE MUST BE GROUNDED**

**8161W @ 240VAC**  
**6112W @ 208VAC**

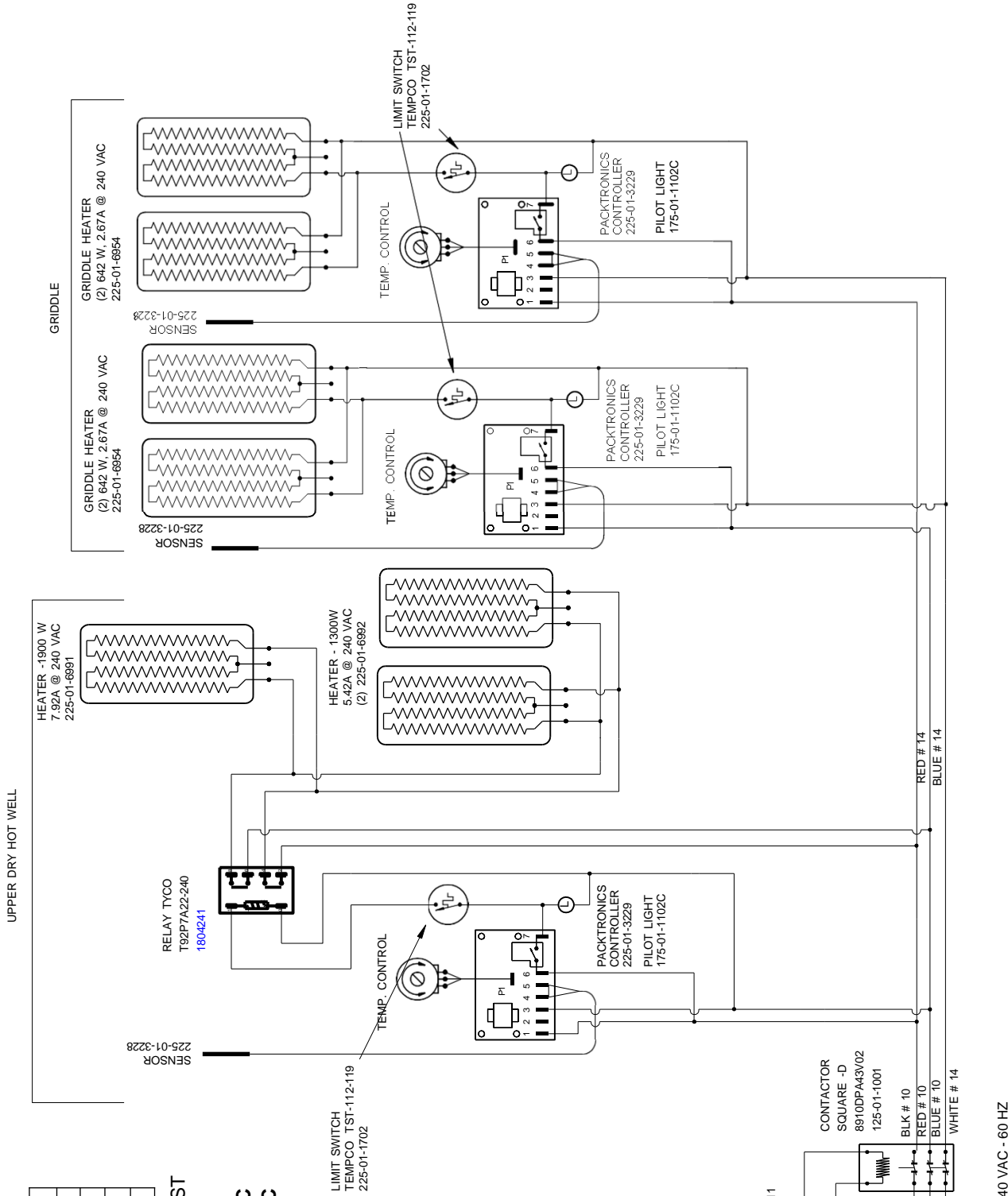

<b>HUSMANN</b> Husmann Corporation, Intl. 13770 Ramona Avenue Chino, CA 91710 (909) 590-4910 Lic.#: 644406		DRAWING BY: JESSE RIOS		PROJECT TITLE: CR3		DRAWING #: W8700021	
REVISIONS:		DATE:	BY:	DATE:	BY:	FILE LOCATION:	
E Added Sensor, T-stat & Pilot Light to each shelf		8/11/11	CB	6/17/08	CB	CR3H-HF-8 W/14" SHELF	
F Changed the Heater Pads, Balanced Loads		1/26/12	CB				
G ECN-CAP-0003963 Changed Relay		10/17/16	CB				

CIRCUIT #3

LOADING	
	120 V
L1	15.0

**NOTE: CASE MUST BE GROUNDED**

RJ-45 NETWORK JACK  
125-01-0202



NOTE FOR GFCI PROTECTION: IF MORE THAN ONE SINGLE RECEPTACLE IS USED IN CONJUNCTION WITH A GFCI DUPLEX RECEPTACLE "DOWNSTREAM" ON THE LOAD SIDE, THE SUM OF ALL RECEPTACLES SHOULD NOT BE MORE THAN 15A

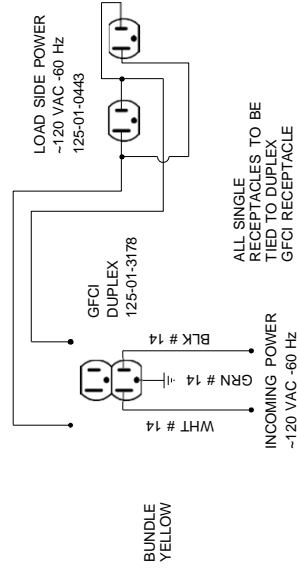

**HUSSMANN**  
Hussmann Corporation, Intl.  
13770 Ramona Avenue  
Chino, CA 91710  
(909) 590-4910 Lic.#: 644406

REVISIONS:

#	DESCRIPTION	DATE	BY
E	Added Sensor, T-stat & Pilot Light to each shelf	8/11/11	CB
F	Changed the Heater Pads; Balanced Loads	1/26/12	CB
G	ECN-CAP-0003963 - Changed Relay	10/11/16	CB

DRAWN BY: JESSE RIOS  
CHECKED BY: CB  
DATE: 6/17/08  
PRODUCTION ORDER #: 621533  
FILE LOCATION:  
PROJECT TITLE: CR3  
DRAWING TITLE:  
CR3H-HF-8 W/14" SHELF

DRAWING #: W8700021  
PAGE 3 OF 3

CIRCUIT #1

LOADING	208 V	240 V
L1	11.1	12.8
L2	14.4	16.6
L3	12.0	13.9

**NOTE: CASE MUST BE GROUNDED**

**6000W @ 240VAC**  
**4503W @ 208VAC**

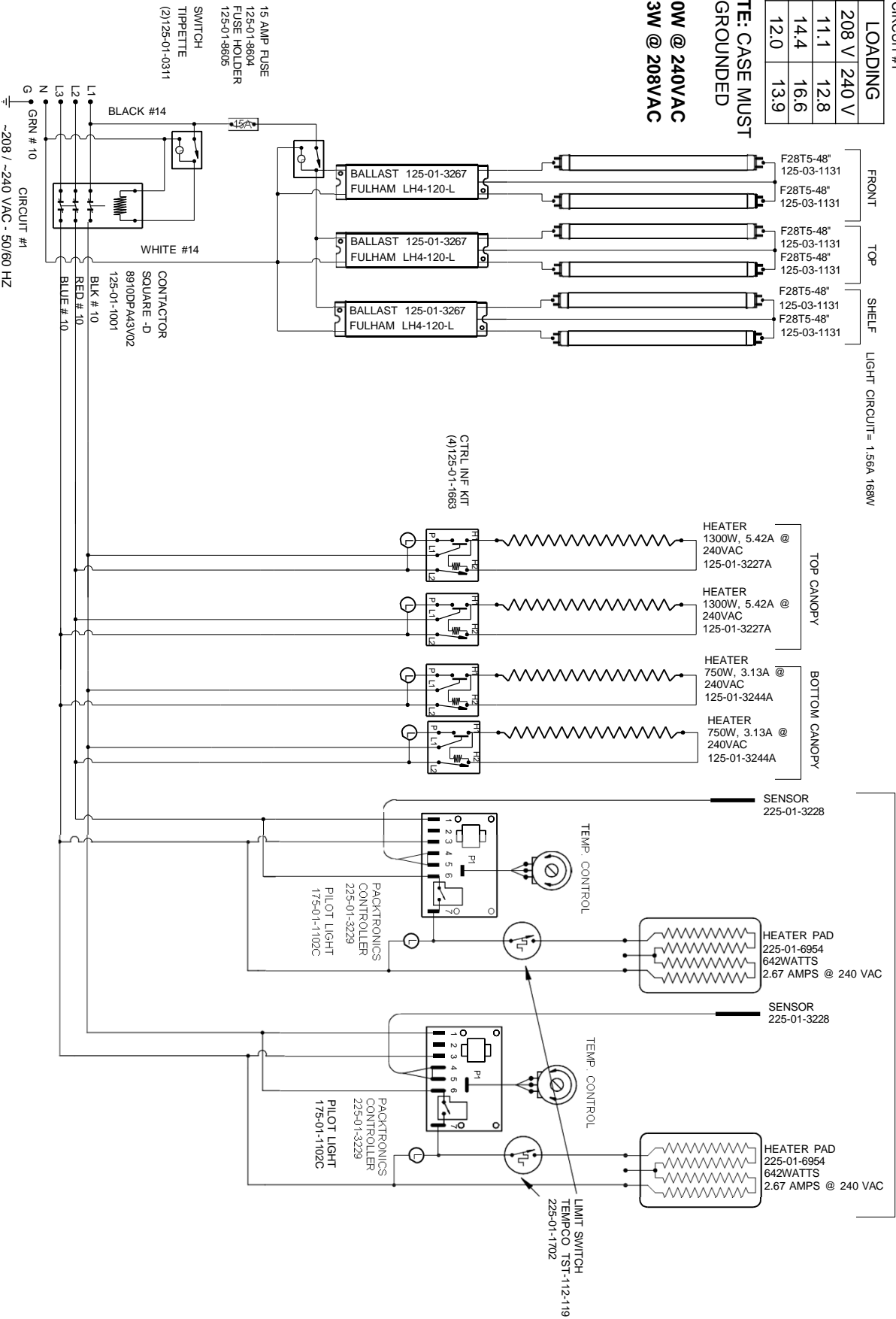

**HUSSMANN®**  
Hussmann Corporation, Intl.  
13770 Ramona Avenue  
Chino, CA 91710  
(909) 590-4910 Lic.#: 644406

REVISIONS:		DRAWN BY: JESSE RIOS		PROJECT TITLE: CR3		DRAWING #: W8700022	
#:	DESCRIPTION:	DATE:	BY:	CHECKED BY:	DATE:	DATE:	DATE:
D	Changed Gridde Heater Pads , Balanced Load	1/26/12	CB	PRODUCTION ORDER #:	621866		
E	Revised Relay and Controller Wiring on Sheet-2	6/6/12	CB	FILE LOCATION:			
F	CN#951945 Added Neutral To Relay	10/29/14	CB				

DRAWING TITLE: CR3H-HF-8 W/10" SHELF  
PAGE 1 OF 3

CIRCUIT #2

LOADING	208 V	240 V
L1	20.8	24.1
L2	20.8	24.1
L3	9.3	10.7

**NOTE: CASE MUST BE GROUNDED**

**8161W @ 240VAC**  
**6112W @ 208VAC**

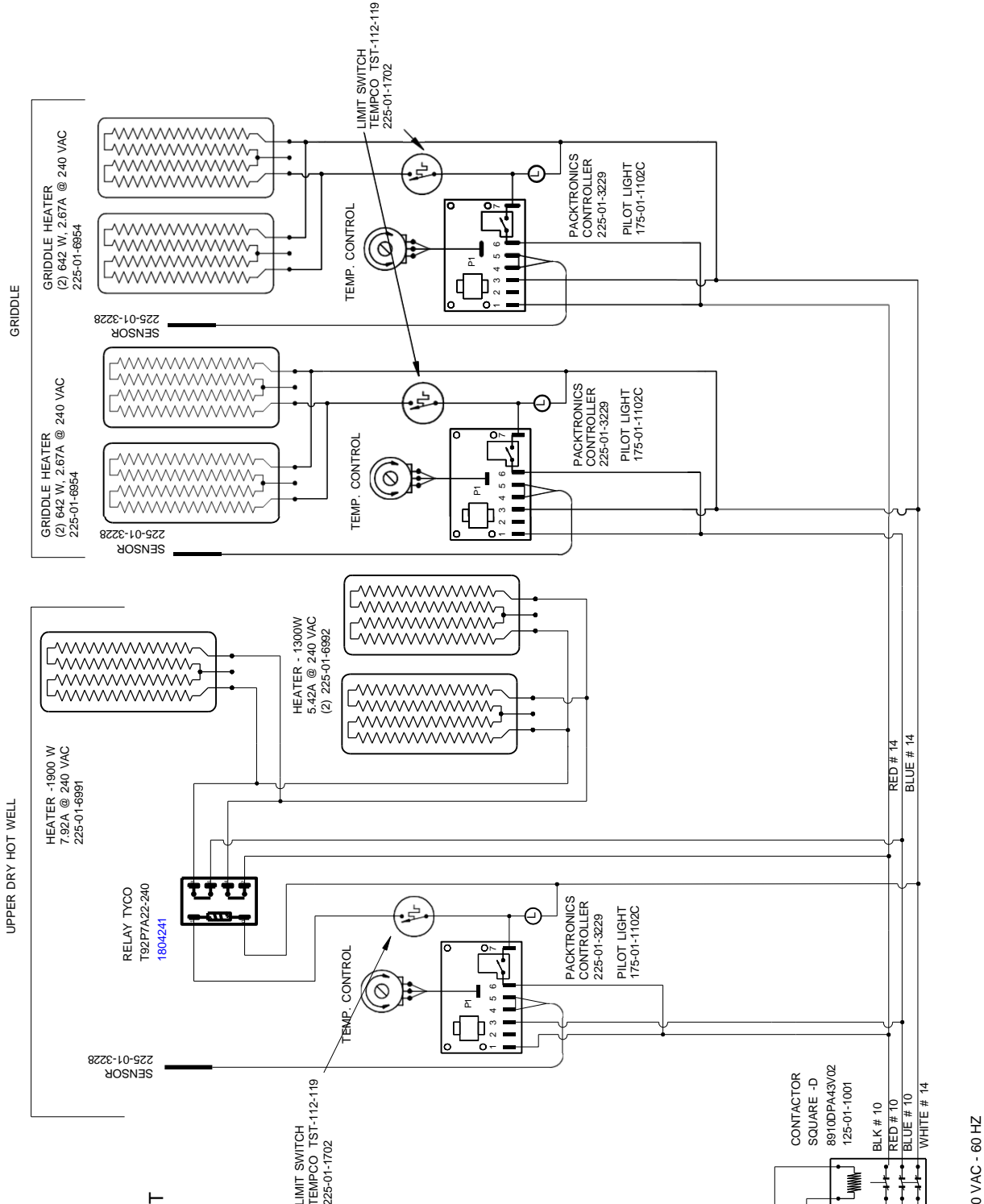

**HUSSMANN**  
Hussmann Corporation, Intl.  
13770 Ramona Avenue  
Chino, CA 91710 Lic.# 644406  
(909) 590-4910

REVISIONS:

#	DESCRIPTION	DATE	BY
D	Changed Griddle Heater Pads - Balanced Load	1/26/12	CB
E	Revised Relay and Controller Wiring on Sheet-2	6/6/12	CB
F	CN#F951945 Added Neutral To Relay	10/29/14	CB

DRAWN BY: JESSE RIOS  
CHECKED BY: CB  
DATE: 7/31/09  
PRODUCTION ORDER #: 621866  
FILE LOCATION:

PROJECT TITLE: CR3

DRAWING #: W8700022  
CR3H-HF-8 W/10" SHELF  
PAGE 2 OF 3

CIRCUIT #3

LOADING	
	120 V
L1	15.0

**NOTE: CASE MUST BE GROUNDED**

RJ-45 NETWORK JACK  
125-01-0202



NOTE FOR GFCI PROTECTION: IF MORE THAN ONE SINGLE RECEPTACLE IS USED IN CONJUNCTION WITH A GFCI DUPLEX RECEPTACLE "DOWNSTREAM" ON THE LOAD SIDE, THE SUM OF ALL RECEPTACLES SHOULD NOT BE MORE THAN 15A

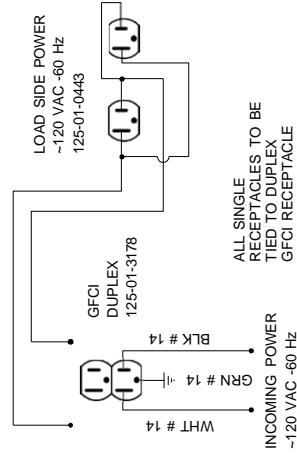

BUNDLE YELLOW

**HUSSMANN**  
Hussmann Corporation, Intl.  
13770 Ramona Avenue  
Chico, CA 95710 Lic.# 644406  
(909) 590-4910

REVISIONS:

#	DESCRIPTION	DATE	BY
D	Changed Griddle Heater Pads , Balanced Load	1/26/12	CB
E	Revised Relay and Controller Wiring on Sheet-2	6/6/12	CB
F	CN#951945 Added Neutral To Relay	10/29/14	CB

DRAWN BY: JESSE RIOS  
CHECKED BY: CB  
DATE: 7/31/09  
PROJECT TITLE: CR3  
PRODUCTION ORDER #: 621866  
DRAWING TITLE: CR3H-HF-8 W/10" SHELF  
FILE LOCATION:

DRAWING #: W8700022  
PAGE 3 OF 3

CIRCUIT #1	LOADING
	208 V / 240 V
L1	11.7 13.2
L2	17.8 20.5
L3	13.1 15.2

**NOTE: CASE MUST BE GROUNDED**  
**5116W @ 208VAC**  
**6776W @ 240VAC**

LIGHT CIRCUIT= 1.56A 168W

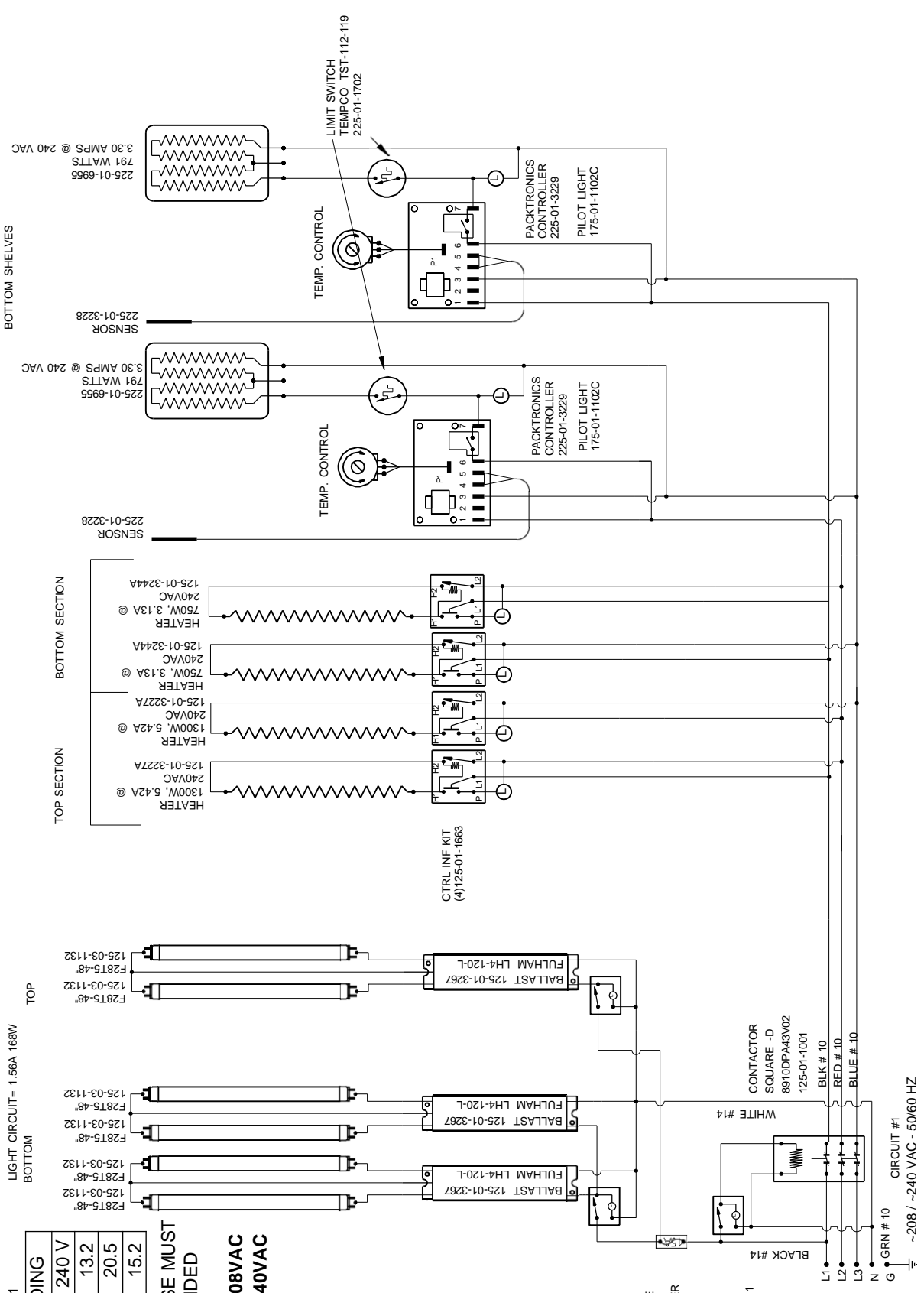

15 AMP FUSE 125-01-8604  
 FUSE HOLDER 125-01-8606  
 SWITCH TIPPETTE (3)125-01-0311  
 CONTACTOR SQUARE - D 8910DPA3/02  
 125-01-1001  
 BLK # 10  
 RED # 10  
 BLUE # 10  
 WHITE #14  
 BLACK #14  
 L1  
 L2  
 L3  
 N  
 G  
 CIRCUIT #1  
 CIRCUIT #2  
 CIRCUIT #3  
 ~208 / ~240 VAC - 50/60 HZ

**TOP SECTION**  
 HEATER 125-01-3227A 1300W, 5.42A @ 240VAC  
 HEATER 125-01-3227A 1300W, 5.42A @ 240VAC  
**BOTTOM SECTION**  
 HEATER 125-01-3244A 750W, 3.13A @ 240VAC  
 HEATER 125-01-3244A 750W, 3.13A @ 240VAC  
**TOP**  
 BALLAST 125-01-3267 FULHAM LH4-120-L  
 BALLAST 125-01-3267 FULHAM LH4-120-L  
 BALLAST 125-01-3267 FULHAM LH4-120-L  
 F28T5-48 125-03-1132  
 F28T5-48 125-03-1132  
 F28T5-48 125-03-1132  
**BOTTOM SHELVES**  
 SENSOR 225-01-3228  
 TEMP. CONTROL  
 TEMP. CONTROL  
 PACKTRONICS CONTROLLER 225-01-3229  
 PACKTRONICS CONTROLLER 225-01-3229  
 PILOT LIGHT 175-01-1102C  
 PILOT LIGHT 175-01-1102C  
 LIMIT SWITCH TEMPCO TST-112-119 225-01-1702  
 3.30 AMPS @ 240 VAC  
 791 WATTS  
 225-01-6955  
 3.30 AMPS @ 240 VAC  
 791 WATTS  
 225-01-6955

**REVISIONS:**  
 # DESCRIPTION  
 B ECN-CAP-0019900 CHANGED SHELF LAYOUT  
 C ECN-CAP-0020433 REWIRED CTRLR AT RELAY

DRAWN BY: MATT GRAMATA  
 CHECKED BY: DATE: 4/14/11  
 BY: CB  
 PRODUCTION ORDER #: 622648  
 FILE LOCATION:  
 PROJECT TITLE: CR3  
 DRAWING TITLE: CR3H-HF-8 with 12" lower shelves & 4" dry well  
 DRAWING #: W8700030  
 Lic.#: 644406

CIRCUIT #2

LOADING	208 V	240 V
L1	20.9	24.1
L2	20.9	24.1
L3	9.3	10.7

**NOTE: CASE MUST BE GROUNDED**

**6136W @ 208VAC**  
**8161W @ 240VAC**

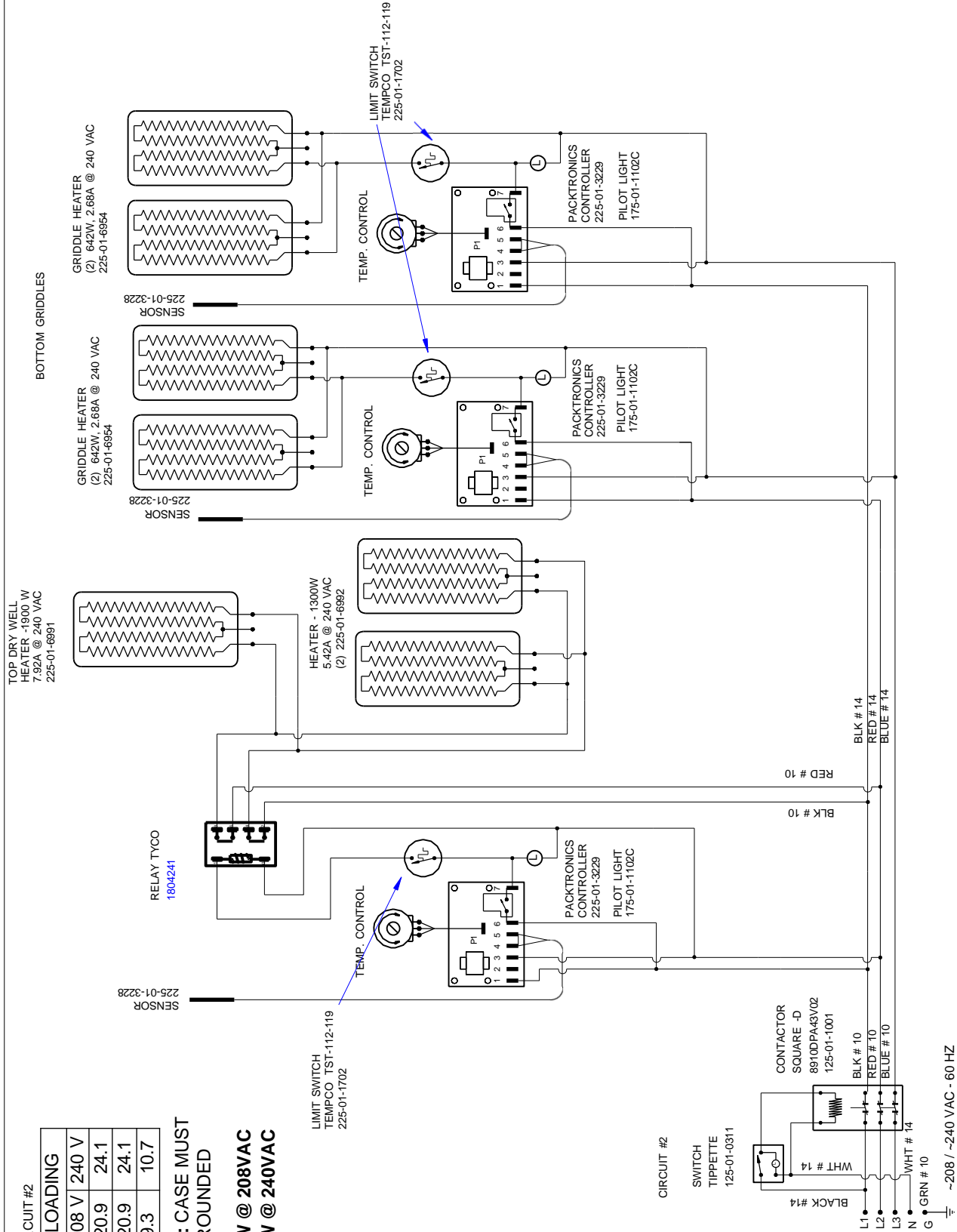

**HUSSMANN**  
Hussmann Corporation, Inc.  
13770 Ramona Avenue  
Chino, CA 91710 Lic.#: 644406  
(909) 590-4910

REVISIONS:

#	DESCRIPTION	DATE	BY
B	ECN-CAP-0019900 CHANGED SHELF LAYOUT	12-5-19	CB
C	ECN-CAP-0020433 REWIRED CTRL AT RELAY	1-21-20	CB

DRAWN BY: MATT GRAMATA  
CHECKED BY: DATE: 4/14/11  
PROJECT TITLE: CR3  
PRODUCTION ORDER #: 622648  
DRAWING TITLE: CR3H-HF-8 with 12" lower shelves & 4" dry well  
FILE LOCATION:

CIRCUIT #3

LOADING	
120 V	
L1	15.0

**NOTE: CASE MUST BE GROUNDED**

RJ-45 NETWORK JACK  
125-01-0202



NOTE FOR GFCI PROTECTION: IF MORE THAN ONE SINGLE RECEPTACLE IS USED IN CONJUNCTION WITH A GFCI DUPLEX RECEPTACLE "DOWNSTREAM" ON THE LOAD SIDE, THE SUM OF ALL RECEPTACLES SHOULD NOT BE MORE THAN 15A

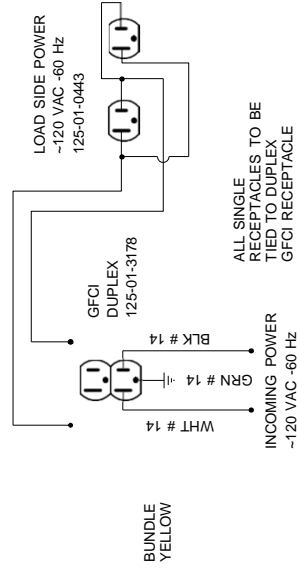

**HUSSMANN**  
Hussmann Corporation, Intl.  
13770 Ramona Avenue  
Chino, CA 91710 Lic.#: 644406  
(909) 590-4910

REVISIONS:

#	DESCRIPTION:	DATE:	BY:
B	ECN-CAP-0019900 CHANGED SHELF LAYOUT	12-5-19	CB
C	ECN-CAP-0020433 REWIRED CTRLR AT RELAY	1-21-20	CB

DRAWN BY: MATT GRAMATA  
CHECKED BY: DATE: 4/14/11  
PROJECT TITLE: CR3  
PRODUCTION ORDER #: 622648  
DRAWING TITLE:  
FILE LOCATION:

DRAWING #: W8700030  
CR3H-HF-8 with 12" lower shelves & 4" dry well  
PAGE 3 OF 3

CIRCUIT #1  
LOADING

208V	240V
110	127
121	140
137.5	166

3675W @ 208VAC  
4891W @ 240VAC

LIGHT CIRCUIT - 104A 112W

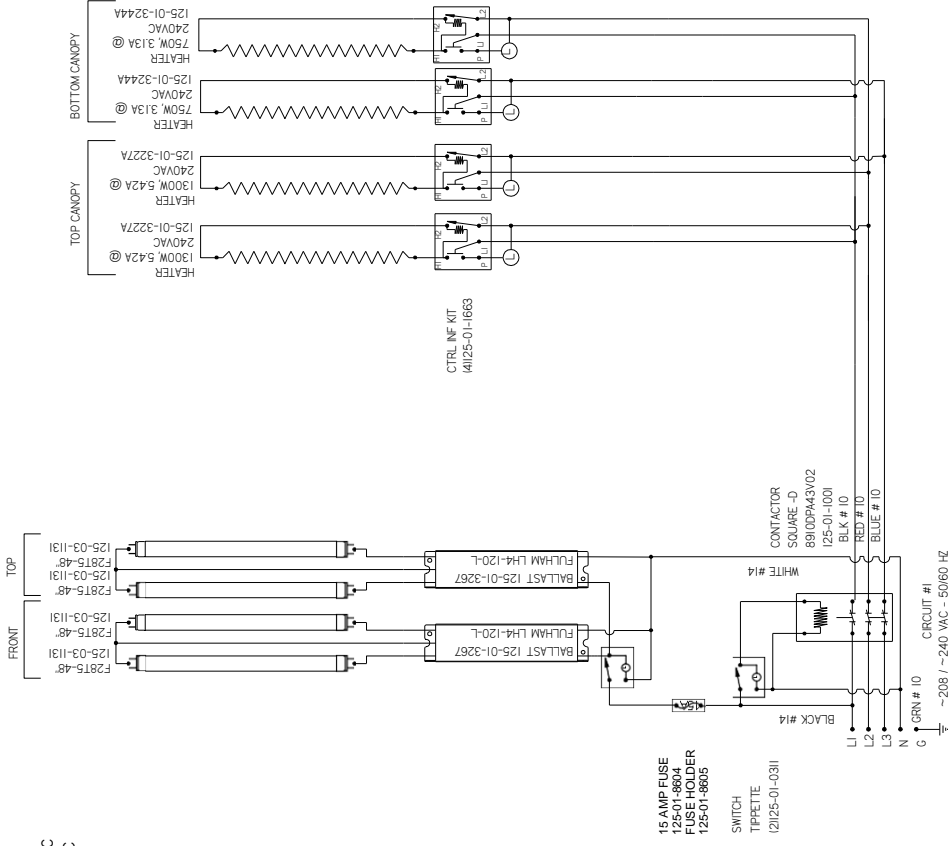

15 AMP FUSE  
125-01-18805

SWITCH  
TIPPETTE  
12125-01-0311

CONTACTOR  
SQUARE-D  
8910DP43V02  
125-01-1001  
BLK # 10  
RED # 10  
BLUE # 10

WHITE #14  
BLACK #14  
L1  
L2  
L3  
N  
G

CIRCUIT #1  
~208 / ~240 VAC - 50/60 HZ

NOTES:  
CASE MUST BE GROUNDED  
WHEN PASSING WIRES THROUGH METAL HOLES A GROMMET MUST BE USED

REV	EN	DATE	REVISION HISTORY	REV BY	CHKD BY	APPR BY
1	ENL-CP-0005867	2/10/06	RELEASED TO PRODUCTION	GB	GB	GB

MATERIAL - N/A  
DATE DRAWN - 10-5-16  
DRAWN BY - CRAIG BOOREY  
REVIEWED BY - CRAIG BOOREY  
APPROVED BY - CRAIG BOOREY  
UNLESS OTHERWISE SPECIFIED DIMENSIONS ARE IN INCHES  
TOLERANCES ARE:  
DECIMALS .XX ±0.3 .XXX ±0.10  
ANGLES ± Z  
PROJECTION

**HUSSMANN**  
DIAGRAM-CP3H-#-8  
W/OUT SHELF

ECN-CP-0003967  
SHEET 1 OF 3  
THIRD ANGLE  
PROJECTION

W6600227 | A

HUSSMAN.L02-CP-11 SHEET SIZE D

REV	EN	DATE	REVISION HISTORY	REV BY	CHKD BY	APPROV BY
1	ECN-CAP-0003967	2016/03/09	RELEASED TO PRODUCTION	GB	GB	GB

CIRCUIT #2  
LOADING

1	208V	240V
L1	208	241
L2	208	241
L3	93	107

6112W @ 208VAC  
8161W @ 240VAC

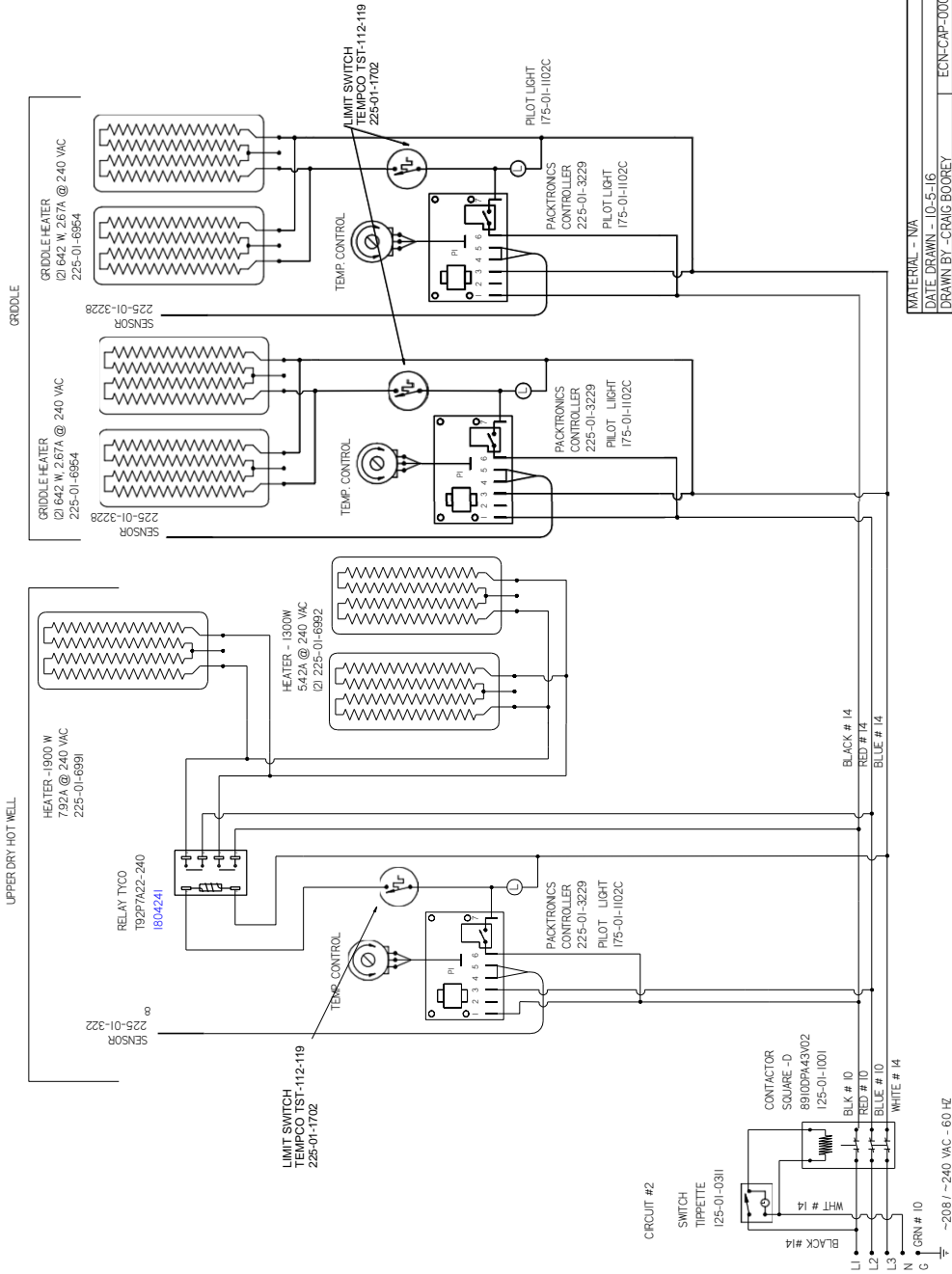

NOTES:  
CASE MUST BE GROUNDED  
WHEN PASSING WIRES THROUGH METAL HOLES A GROMMET MUST BE USED

MATERIAL - N/A  
DATE DRAWN - 10-5-16  
DRAWN BY - CRAIG BOOREY  
REVIEWED BY - CRAIG BOOREY  
APPROVED BY - CRAIG BOOREY  
UNLESS OTHERWISE SPECIFIED DIMENSIONS ARE IN INCHES.  
TOLERANCES ARE:  
DECIMALS .XX ±0.3 .XXX  
±0.0

ECN-CAP-0003967  
REF -  
SHEET 20F-3  
THIRD ANCL  
E  
PROJECTION

**HUSSMANN**  
**DIAGRAM-CR3H-F-8**  
**W/OUT SHELF**

W6600227 | A

ANGLES ± Z

CIRCUIT #3  
LOADING

20V			
150			

REVISION HISTORY		REV BY	CHKD BY	APPR BY
REV	EN	DATE		
X	EN-CAP-0003967	2/10/2016		
	RELEASED TO PRODUCTION			

RJ45 NETWORK JACK  
125-01-0202



NOTE FOR GFCI PROTECTION IF MORE THAN ONE SINGLE RECEPTACLE IS USED IN CONJUNCTION WITH A GFCI DUPLEX RECEPTACLE "DOWNSTREAM" ON THE LOAD SIDE THE SUM OF ALL RECEPTACLES SHOULD NOT BE MORE THAN 15A

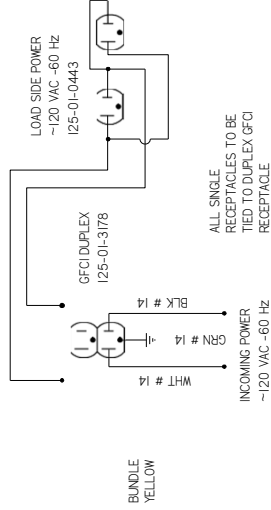

MATERIAL - N/A		DATE DRAWN - 10-5-16		ECN-CAP-0003967	
DRAWN BY - CRAIG BOOREY		REVIEWED BY - CRAIG BOOREY		APPROVED BY - CRAIG BOOREY	
UNLESS OTHERWISE SPECIFIED DIMENSIONS ARE IN INCHES TOLERANCES ARE		SHEET 30F-3		THIRD	
DECIMALS .XX ±0.3 .XXX		ANGL		E	
±0.0		ANGLES ± 2°		PROJECTION	

**HUSSMANN**  
DIAGRAM-CR3H-F-8  
W/OUT SHELF

W6600227

A

NOTES:  
CASE MUST BE GROUNDED  
WHEN PASSING WIRES THROUGH METAL HOLES A GROMMET MUST BE USED

CIRCUIT #1

LOADING	208 V	240 V
L1	27.6	31.9
L2	25.6	29.6
L3	23.1	26.7

**NOTE: CASE MUST BE GROUNDED**

**12221W @ 240VAC**  
**9163W @ 208VAC**

CANOPY LIGHTING FRONT CASE SHELVES

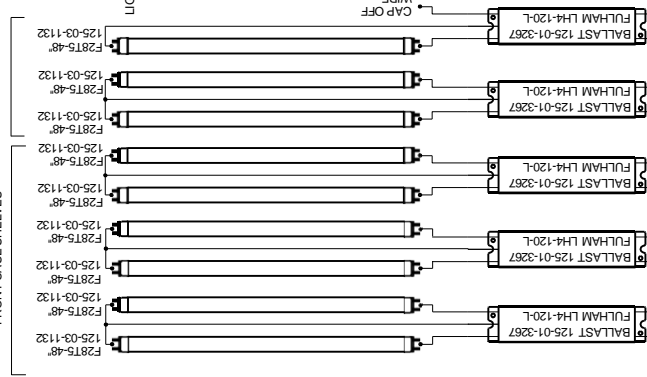

TOP CASE

LIGHT CIRCUIT 252W 2.33 AMPS

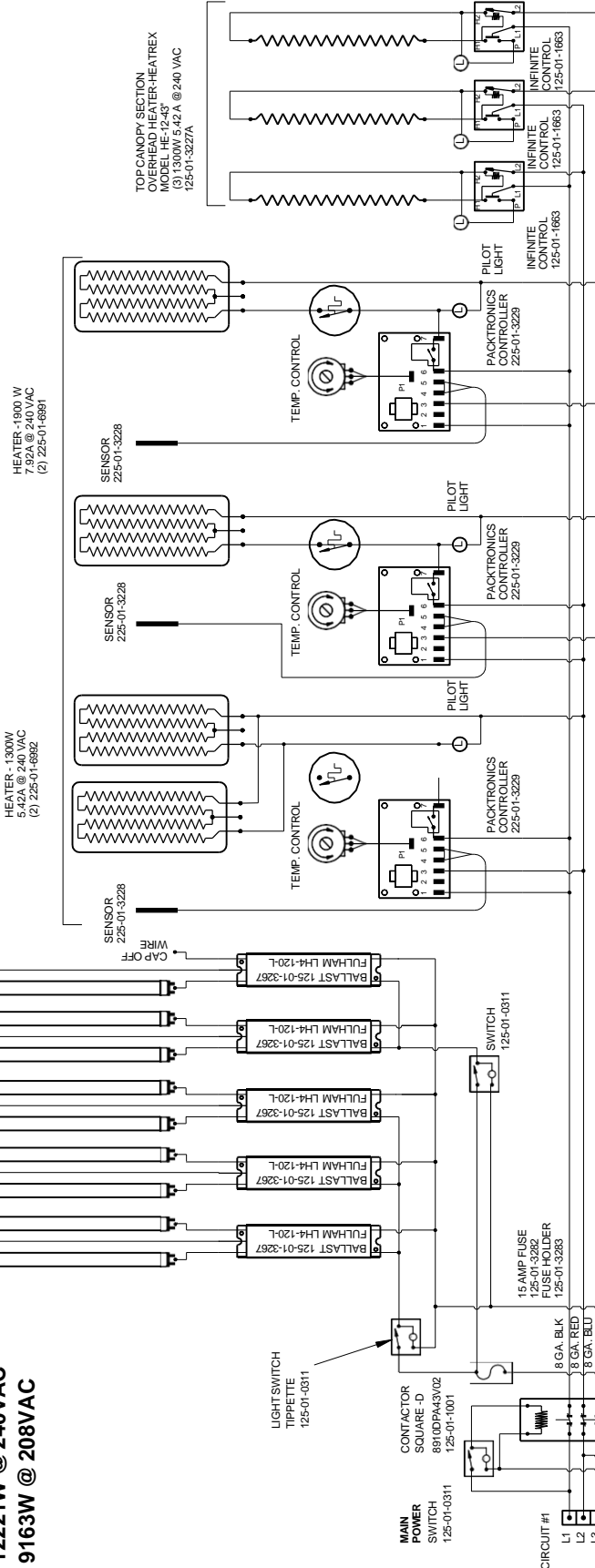

CIRCUIT #2  
SEE PAGE 2 OF 3

L1  
L2  
L3

-208 / 240 VAC - 3Ø - 50/60 Hz. - 4W

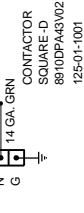

DRAWING #: W6600066

PROJECT TITLE: CR3

DRAWN BY: CRAIG BOOREY  
DATE: 12/14/12

CHECKED BY: CB

PRODUCTION ORDER #:

FILE LOCATION:

DATE: 8/22/17

DESCRIPTION:

E ECN-0009100 ADDED LIMIT SWITCHED  
F ECN-0013669 REVISED TOP HEATERS/LOADS  
G ECN-COD-0014517 REVISED WIRE GAUGES

**HUSSMANN**  
Hussmann Corporation, Intl.  
13770 Ramona Avenue  
Chino, CA 91710  
(909) 590-4910 Lic.#: 644406

CR3H-HF-12 W/10" SHELF

PAGE 1 OF 3

CIRCUIT #2

LOADING	208 V	240 V
L1	19.3	22.3
L2	19.3	22.3
L3	19.3	22.3

**NOTE: CASE MUST BE GROUNDED**

**9270W @ 240VAC**  
**6953W @ 208VAC**

BOTTOM  
 GRIDDED HEATERS  
 MODEL HE-12-43\*  
 (3) 750W @240 VAC  
 225-01-6954

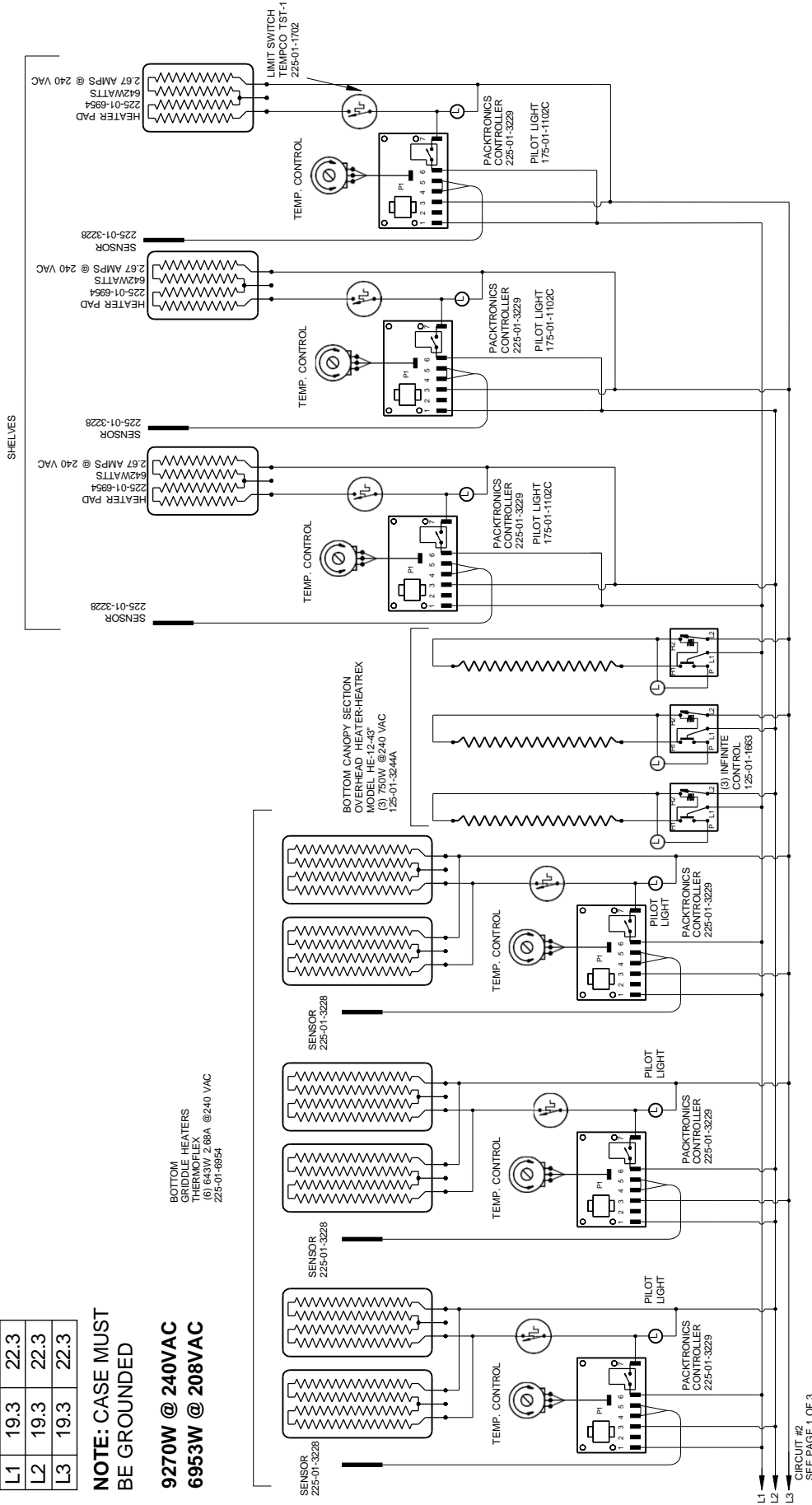

CIRCUIT #2  
 SEE PAGE 1 OF 3

**HUSSMANN**  
 Hussmann Corporation, Inc.  
 13770 Ramona Avenue  
 Chino, CA 91710 Lic.#: 644406  
 (909) 590-4910

REVISIONS:

#	DESCRIPTION	DATE	BY
E	ECN-0009100 ADDED LIMIT SWITCHED	8/22/17	CB
F	ECN-0013669 REVISED TOP HEATERS/LOADS	6/21/21	CB
G	ECN-COD-0014517 REVISED WIRE GAUGES	7/29/31	CB

DRAWN BY: CRAIG BOOREY  
 CHECKED BY: CB  
 DATE: 12/14/12  
 PROJECT TITLE: CR3  
 PRODUCTION ORDER #:  
 DRAWING TITLE: CR3H-HF-12 W/10" SHELF  
 FILE LOCATION:

DRAWING #: W6600066

CIRCUIT #3

LOADING	
120 V	
L1	15.0

**NOTE: CASE MUST BE GROUNDED**

RJ-45 NETWORK JACK  
125-01-0202



NOTE FOR GFCI PROTECTION: IF MORE THAN ONE SINGLE RECEPTACLE IS USED IN CONJUNCTION WITH A GFCI DUPLEX RECEPTACLE "DOWNSTREAM" ON THE LOAD SIDE, THE SUM OF ALL RECEPTACLES SHOULD NOT BE MORE THAN 15A

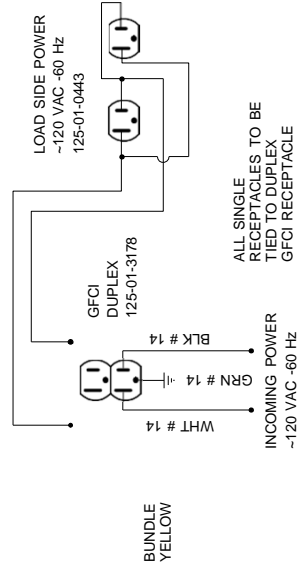

**HUSSMANN**  
Hussmann Corporation, Inc.  
13770 Ramona Avenue  
Chino, CA 91710 Lic.#: 644406  
(909) 590-4910

REVISIONS:

#	DESCRIPTION	DATE	BY
E	ECN-0009100 ADDED LIMIT SWITCHED	8/22/17	CB
F	ECN-0013669 REVISED TOP HEATERS/LOADS	6/21/21	CB
G	ECN-COD-0014517 REVISED WIRE GAUGES	7/29/31	CB

DRAWN BY: CRAIG BOOREY  
CHECKED BY: CB  
DATE: 12/14/12  
PROJECT TITLE: CR3  
PRODUCTION ORDER #:  
DRAWING TITLE:  
FILE LOCATION: CR3H-HF-12 W/10" SHELF

DRAWING #: W6600066  
PAGE 3 OF 3

CIRCUIT #1  
LOADING

206V	Z40
124	143
L	47
	44Z

2579W @ 208VAC  
3504W @ 240VAC

BL46 NETWORK  
JACK 125-01-0202

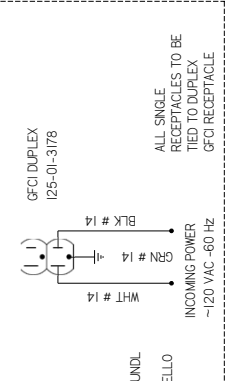

LOWER FRONT SECTION  
LIGHT CIRCUIT = 16A 17.6W

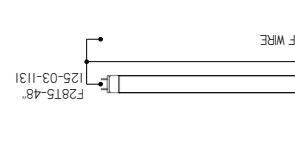

LIGHT CIRCUIT = 28W .26A

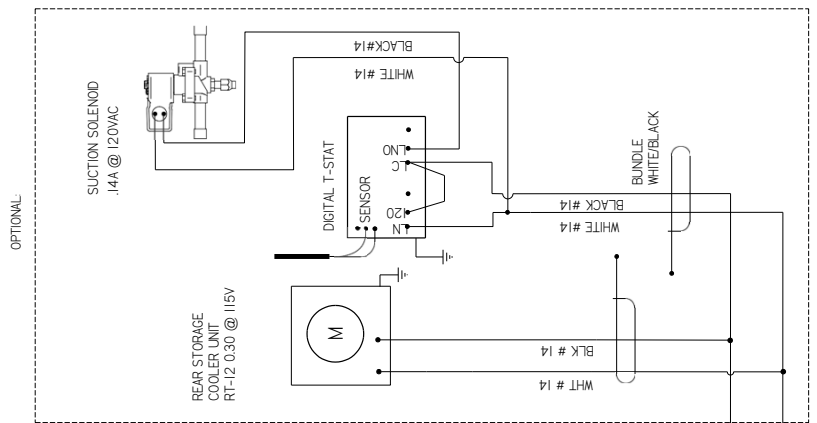
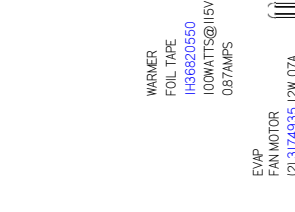

HEATING ELEMENT  
1300W 5.42A @ 240VAC  
125-01-3227A

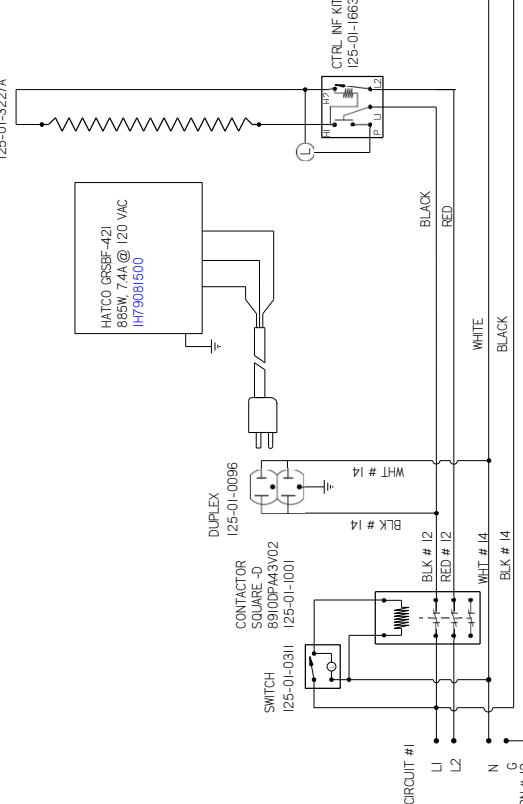

**HUSSMANN**  
DIAGRAM-R3-P-4-SH  
-4CR-1-DS-R

MATERIAL - N/A  
DATE DRAWN - 6-15-15  
DRAWN BY - CRAIG BOOREY  
REVIEWED BY - CRAIG BOOREY  
APPROVED BY - CRAIG BOOREY  
UNLESS OTHERWISE SPECIFIED DIMENSIONS ARE IN INCHES  
TOLERANCES ARE:  
DIMENSIONS .XX ±.03 .XXX  
±.00  
ANGLES ± 2°

ECN# - 987576  
REF -  
SHEET 1 OF 1  
THIRD PROJECTION

W6600152 | D

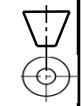

NOTES:  
CASE MUST BE GROUNDED

CIRCUIT #1

LOADING	
208 V	240 V
L1	13.0
L2	11.6
	13.4

**NOTE: CASE MUST BE GROUNDED**

**3624W @ 240VAC**  
**2711W @ 208VAC**

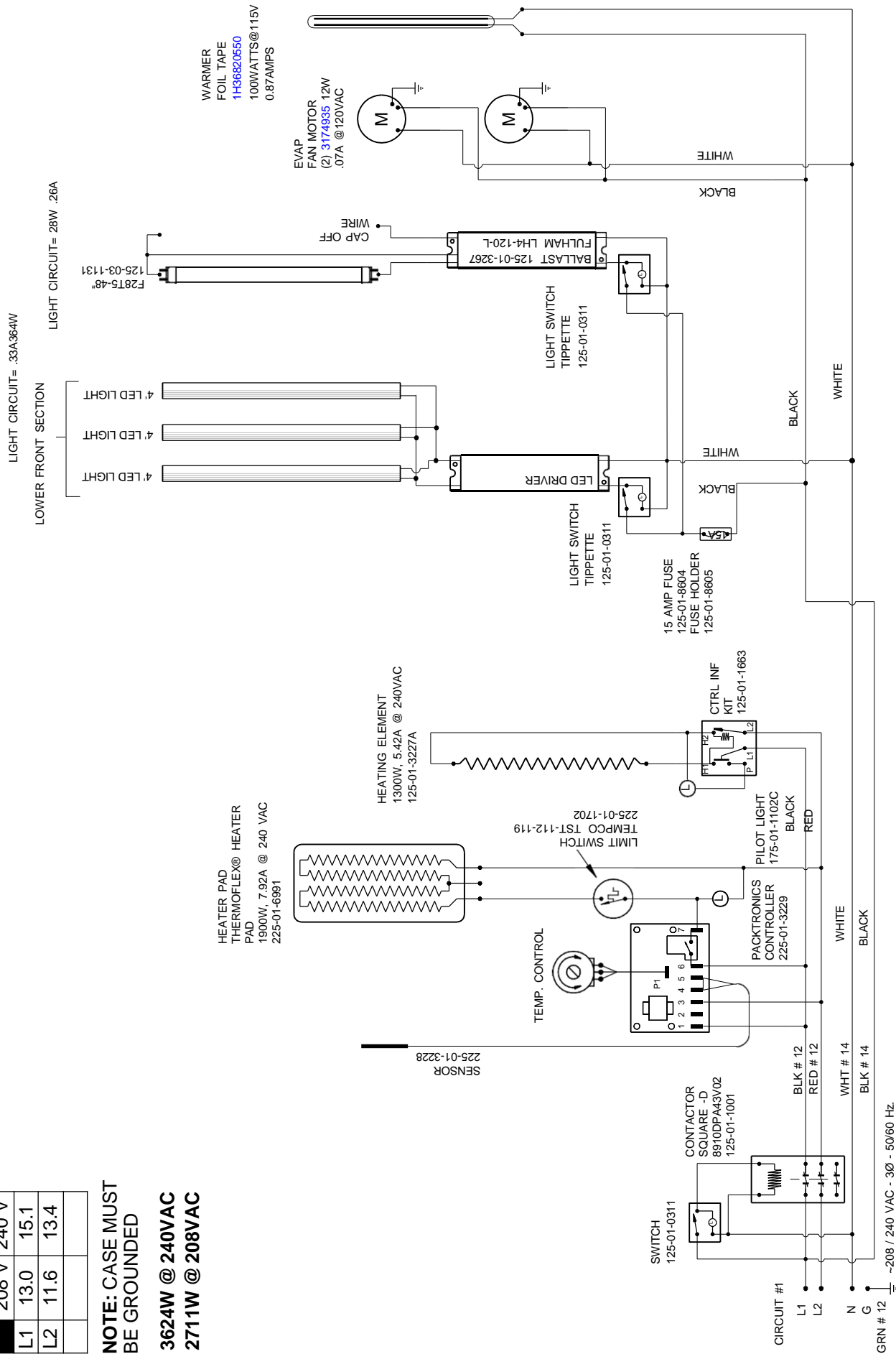

REVISIONS:

#	DESCRIPTION:	DATE:	BY:
G.	ECN-CAP-0012699 Changed Anti-Sweat Heater	06/07/18	CB
H.	ECN-COD-0011847 Added Fuse and Holder	10/26/20	CB
I.	ECN-COD-0018141 Changed Fan Motor	7/5/23	CB

DRAWN BY: JESSE RIOS  
 CHECKED BY: DATE: 4/11/07  
 PRODUCTION ORDER #: FILE LOCATION:

CIRCUIT #2

LOADING
120 V
L1 15.0

**NOTE: CASE MUST BE GROUNDED**

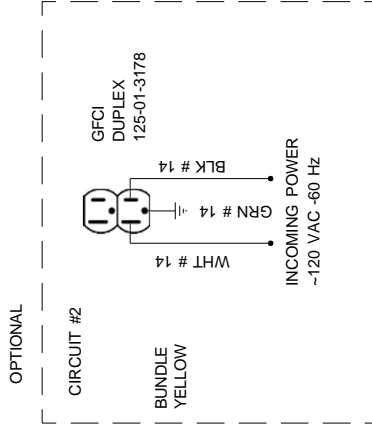
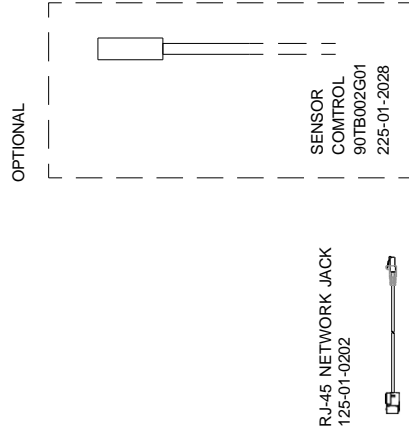
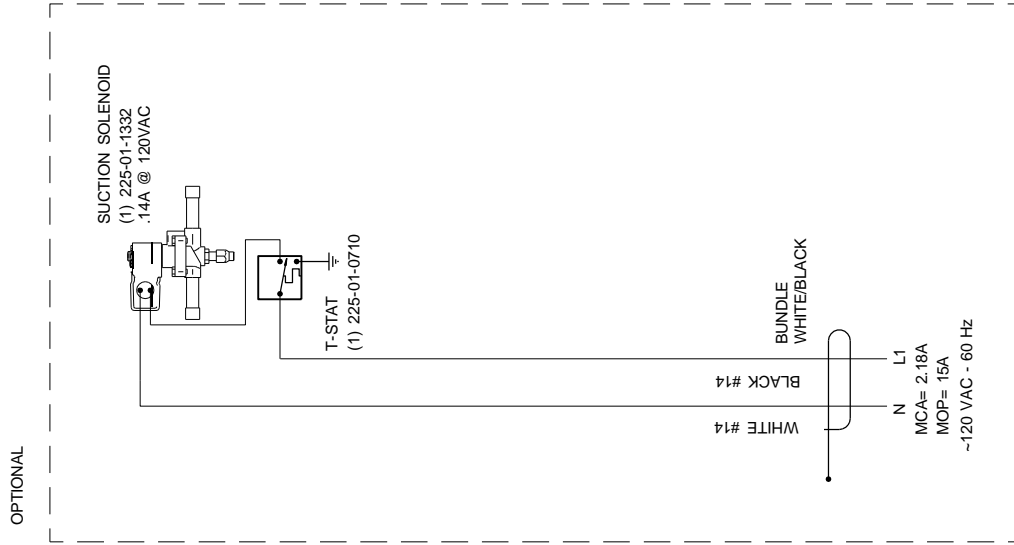

REVISIONS:

#:	DESCRIPTION:	DATE:	BY:
G.	ECN-CAP-0012699 Changed Anti-Sweat Heater	06/07/18	CB
H.	ECN-COD-0011847 Added Fuse and Holder	10/26/20	CB
I.	ECN-COD-0018141 Changed Fan Motor	7/5/23	CB

DRAWN BY: JESSE RIOS

CHECKED BY: DATE: 4/11/07

PRODUCTION ORDER #:

FILE LOCATION:

PROJECT TITLE:

DRAWING TITLE:

CR3H-4-REM

DRAWING #: W8700011

CIRCUIT #1

LOADING	208 V	240 V
L1	14.1	16.3
L2	12.9	14.9

**NOTE: CASE MUST BE GROUNDED**

**2933W @ 208VAC**  
**3912W @ 240VAC**

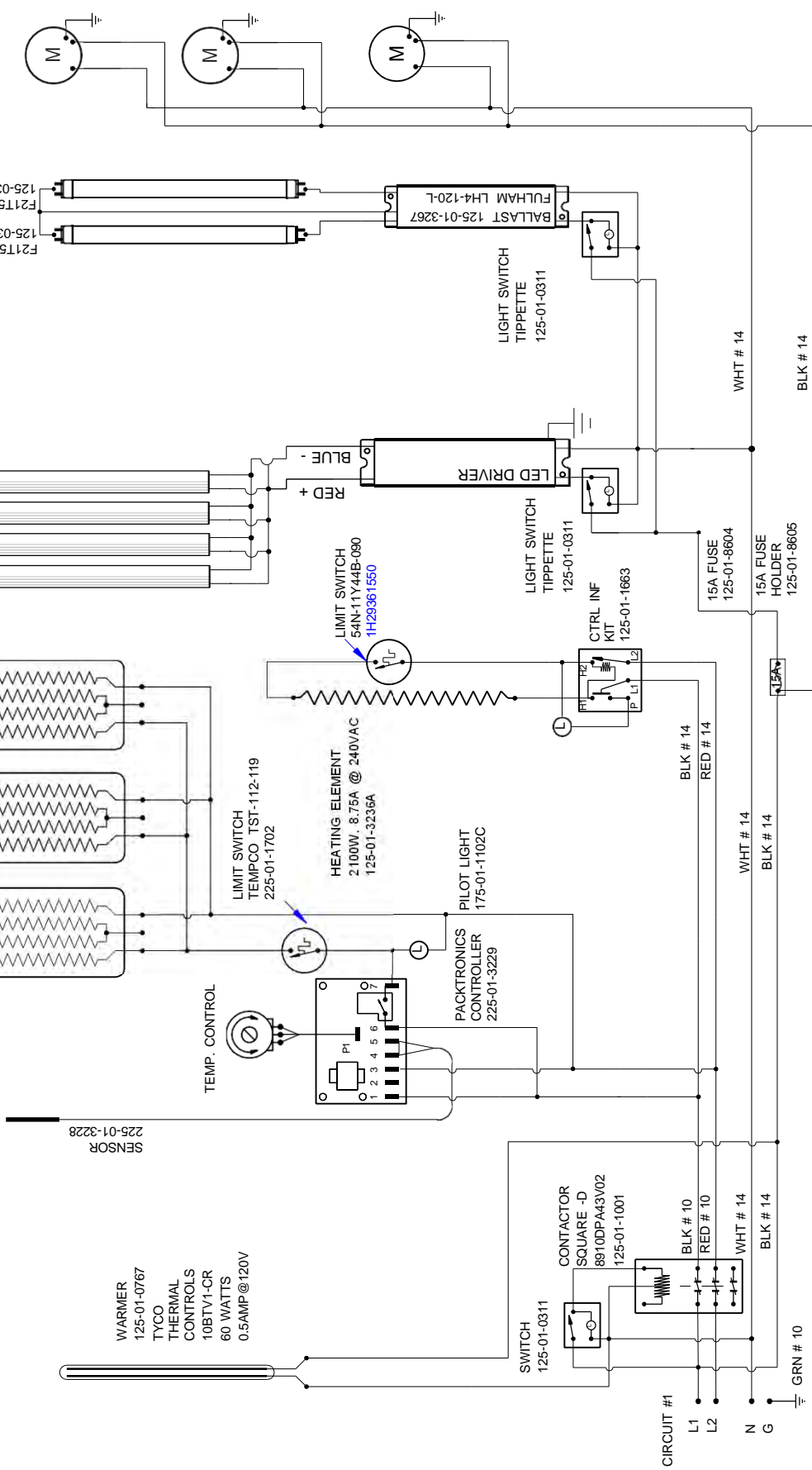

-208 / 240 VAC - 60 Hz.

CIRCUIT #2

LOADING	
120 V	
L1 15.0	

**NOTE: CASE MUST BE GROUNDED**

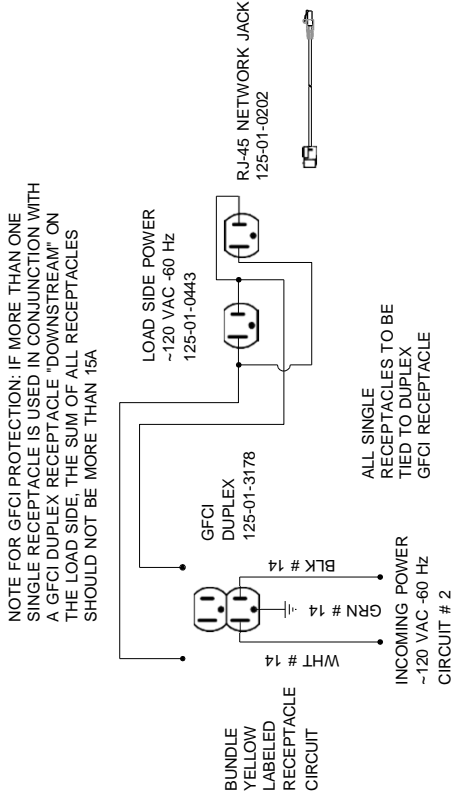

REVISIONS:

#	DESCRIPTION:	DATE:	BY:
C	Placed fans/heater tape before light circuit fuse	3/19/10	JR
D	ECN-CAP-0006456 Changed Lights & Fans	2/13/17	CB
E	ECN-COD-0018141 Changed Fan Motors	7/5/23	CB

DRAWN BY: JESSE RIOS	DATE: 12/1/08
CHECKED BY:	PRODUCTION ORDER #: 603701
FILE LOCATION:	

PROJECT TITLE: R3
DRAWING TITLE: CR3H-6-REM

CIRCUIT #1

LOADING	208 V	240 V
L1	21.2	24.5
L2	19.2	22.1

**NOTE: CASE MUST BE GROUNDED**

**4411W @ 208VAC**  
**5880W @ 240VAC**

WARMER  
FOIL TAPE  
1H36821550  
150 WATTS @ 115V  
1.30 AMPS

SENSOR  
225-01-3228

TOP

HEATER PAD  
1300W, 5.42A @ 240 VAC  
225-01-6892

HEATER PAD  
1900W, 7.92A @ 240 VAC  
225-01-6891

LIMIT SWITCH  
TEMPCO TST-112-119  
(2) 225-01-1702

TEMP CONTROL

HEATING ELEMENT  
2100W, 8.75A @ 240VAC  
125-01-3236A

PACKETRONICS  
CONTROLLER  
225-01-3229

PILOT LIGHT  
175-01-1102C

TOP LIGHT CIRCUIT= .39A 42W

TOP

F21T5-36  
125-03-1128

BALLAST  
FULHAM LH4-120-L  
125-01-3267

LIGHT SWITCH  
TIPPETTE  
125-01-0311

WHT # 14

BLK # 14

15A FUSE  
HOLDER  
125-01-8605

15A FUSE  
125-01-8604

WHT # 14  
BLK # 14

WHT # 14  
BLK # 14

WHT # 14  
BLK # 14

WHT # 14  
BLK # 14

WHT # 14  
BLK # 14

WHT # 14  
BLK # 14

WHT # 14  
BLK # 14

WHT # 14  
BLK # 14

WHT # 14  
BLK # 14

FRONT SHELF

LIGHT CIRCUIT .39A 36W

EVAP  
FAN MOTOR 12W  
(3) 3174935 .07A EA

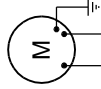

ADV DRIVER  
LEDINTA-0024-41FO  
0499399

LIGHT SWITCH  
TIPPETTE  
125-01-0311

-208 / 240 VAC - 60 HZ.

CIRCUIT #1

L1

L2

N

G

GRN # 8

-208 / 240 VAC - 60 HZ.

REVISIONS:  
# DESCRIPTION:

#	DATE	BY
D	4/21/12	CB
E	6/8/18	CB
F	7/5/23	CB

Added Fan Motor to DWG  
ECN-CAP-0012699 Changed Anti-Sweat Heater  
ECN-COD-0018141 Changed Fan Motor

DRAWN BY: JESSE RIOS  
CHECKED BY:

DATE: 11/9/09  
PRODUCTION ORDER #: 622060  
FILE LOCATION:

PROJECT TITLE: R3

DRAWING TITLE:  
CR3H-6-REM

DRAWING #: W1800195

CIRCUIT #2

LOADING	
120 V	
L1 15.0	

**NOTE: CASE MUST BE GROUNDED**

NOTE FOR GFCI PROTECTION: IF MORE THAN ONE SINGLE RECEPTACLE IS USED IN CONJUNCTION WITH A GFCI DUPLEX RECEPTACLE "DOWNSTREAM" ON THE LOAD SIDE, THE SUM OF ALL RECEPTACLES SHOULD NOT BE MORE THAN 15A

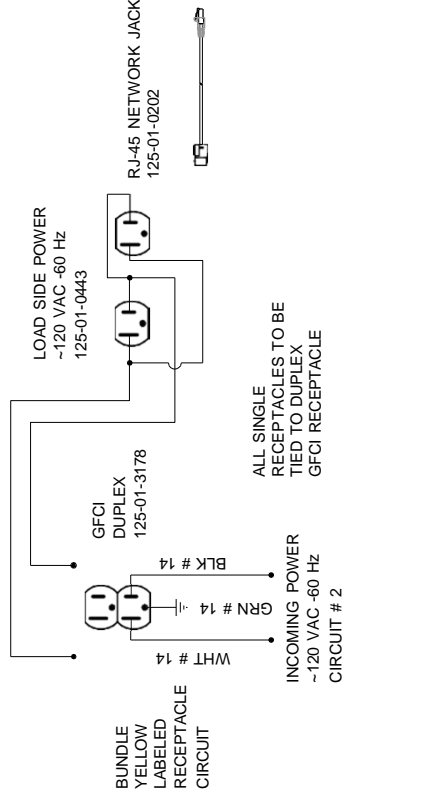

REVISIONS:

#	DESCRIPTION:	DATE:	BY:
D	Added Fan Motor to DWG	4/21/12	CB
E	ECN-CAP-0012699 Changed Anti-Sweat Heater	6/8/18	CB
F	ECN-COD-0018141 Changed Fan Motor	7/5/23	CB

DRAWN BY: JESSE RIOS	PROJECT TITLE: R3
CHECKED BY:	DATE: 11/9/09
PRODUCTION ORDER #: 622060	DRAWING TITLE: CR3H-6-REM
FILE LOCATION:	

CIRCUIT #1

LOADING	208 V	240 V
L1	21.2	24.5
L2	19.2	22.1

**NOTE: CASE MUST BE GROUNDED**

**4411W @ 208VAC**  
**5880W @ 240VAC**

LIGHT CIRCUIT= .33A 36W  
 LOWER FRONT SECTION  
 TOP LIGHT CIRCUIT= .39A 42W

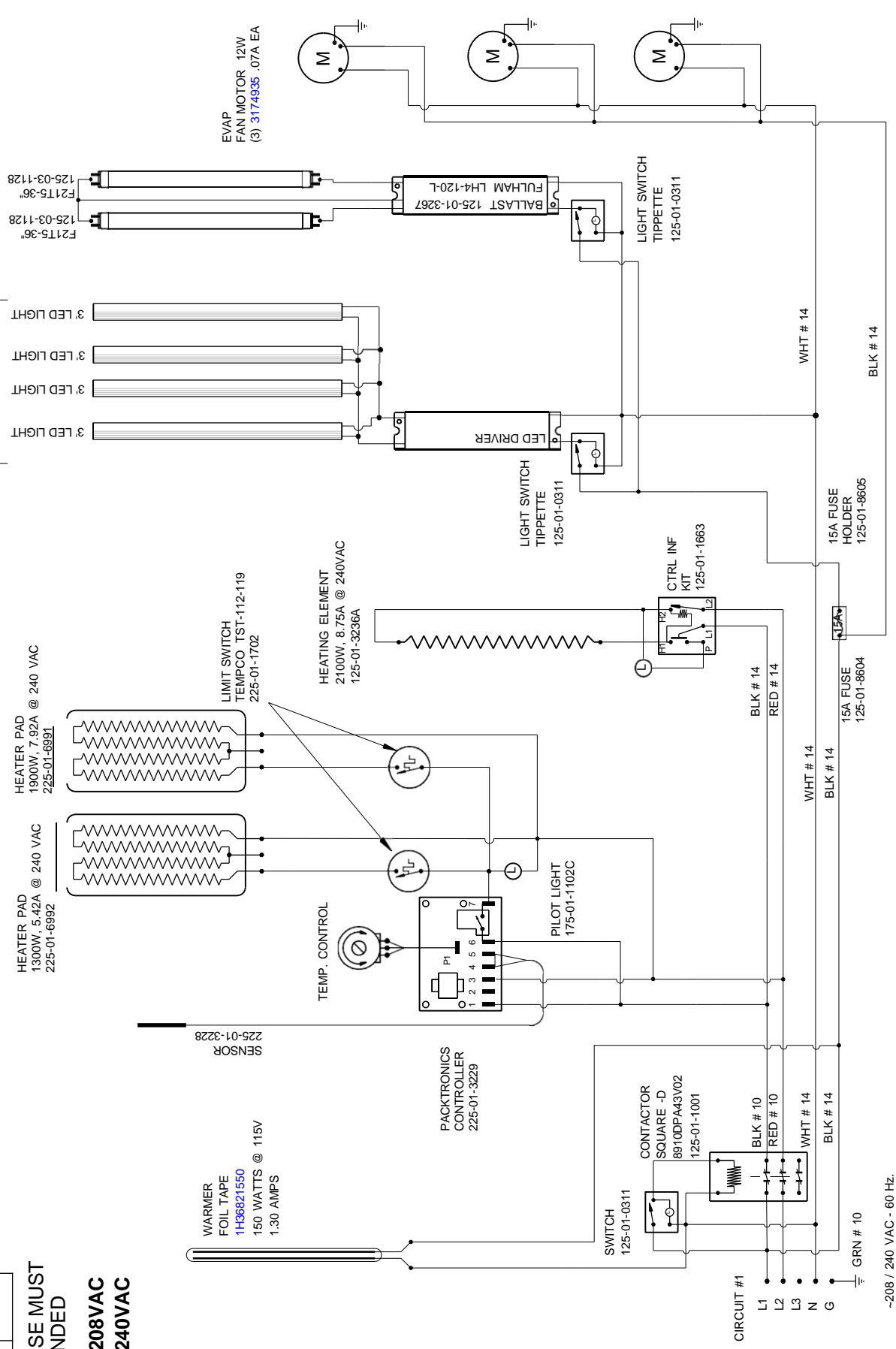

-208 / 240 VAC - 60 Hz.

CIRCUIT #2

LOADING	
120 V	
L1 15.0	

**NOTE: CASE MUST BE GROUNDED**

NOTE FOR GFCI PROTECTION: IF MORE THAN ONE SINGLE RECEPTACLE IS USED IN CONJUNCTION WITH A GFCI DUPLEX RECEPTACLE "DOWNSTREAM" ON THE LOAD SIDE, THE SUM OF ALL RECEPTACLES SHOULD NOT BE MORE THAN 15A

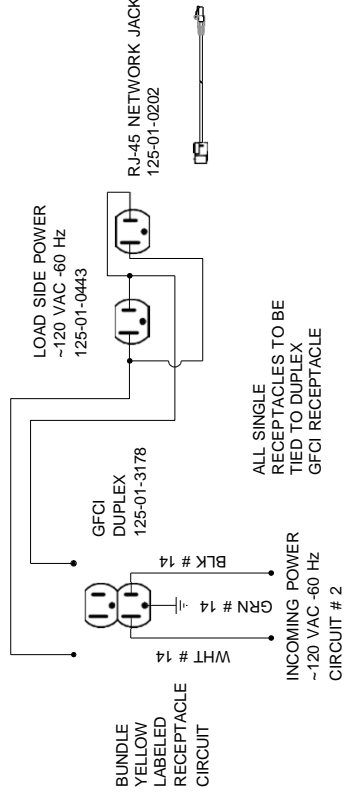

REVISIONS:

#	DESCRIPTION:	DATE:	BY:
L	CN#634531 Added a 2nd limit Switch Back	7/13/12	CB
M	ECN-AP-0012699 Changed Anti-Sweat Heater	6/8/18	CB
N	ECN-COD-0018141 Changed Fan Motor	7/5/23	CB

DRAWN BY: JESSE RIOS

CHECKED BY:

DATE: 8/3/07

PROJECT TITLE: R3

DRAWING #: W8700015

DRAWING TITLE:

CR3H-6-REM

CIRCUIT #1

LOADING	208 V	240 V
L1	23.8	27.0
L2	20.9	24.2
L3	9.4	10.8

**NOTE: CASE MUST BE GROUNDED**

**6497W @ 208VAC**  
**8591W @ 240VAC**

LIMIT SWITCH  
 TEMPCO TST-112-119  
 225-01-1702

PACKTRONICS  
 CONTROLLER  
 225-01-3229

CONTACTOR  
 SQUARE -D  
 8910DPA43V02  
 125-01-1001

SWITCH  
 125-01-0311

CIRCUIT #1  
 L1  
 L2  
 L3  
 N  
 G

-208 / 240 VAC - 60 HZ.

UPPER DRY HOT WELL

HEATER -1900 W  
 7.92A @ 240 VAC  
 225-01-6991

RELAY TYCO  
 T92P7A22-240  
 1804241

SENSOR  
 225-01-3228

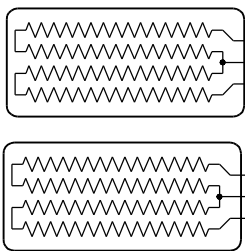

HEATER - 1300W  
 5.42A @ 240 VAC  
 (2) 225-01-6992

HEATING ELEMENT  
 1300W, 5.42A @ 240VAC  
 (2)125-01-3227A

CTRL INF KIT  
 (2)125-01-1663

LIGHT CIRCUIT= .51A 56W

TOP SECTION

(2)FP28/835T5-48  
 125-03-1132

(2)125-01-3267  
 BALLAST 125-01-3267  
 FULLHAM LH4-120-L

LED DRIVER

15A FUSE  
 125-01-8604  
 FUSEBLOCK  
 125-01-8605

LIGHT SWITCH  
 TTPETTE  
 125-01-0311

WARMER  
 FOIL TAPE  
 1H36622550  
 200 WATTS @ 115V  
 1.74 AMPS

BUNDLE  
 PURPLE

EVAP  
 FAN MOTOR  
 (4) 3174935  
 12W .07A @ 120VAC

LIGHT CIRCUIT .44A 48W  
 FRONT SHELF

4 L.E.D. LIGHT  
 4 L.E.D. LIGHT  
 4 L.E.D. LIGHT  
 4 L.E.D. LIGHT

CIRCUIT #2

LOADING	
120 V	
L1 15.0	

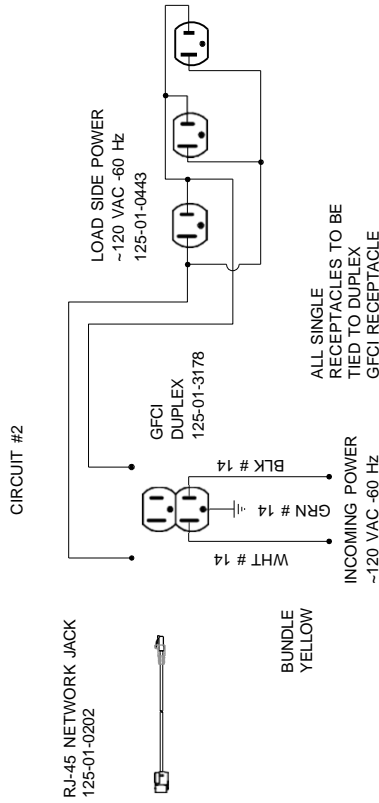

REVISIONS:

#	DESCRIPTION:	DATE:	BY:
F	ECN-CAP-0002614 Revised Trakstat Wiring	8/19/16	CB
G	ECN-CAP-0012699 Changed Anti-Sweat Heater	6/8/18	CB
H	ECN-COD-0018141 Changed Fan Motor	7/5/23	CB

DRAWN BY: JESSE RIOS  
CHECKED BY:   
DATE: 11/6/08

PRODUCTION ORDER #:  
FILE LOCATION:

PROJECT TITLE: **R3**  
DRAWING TITLE:  
**R3H-8-REM With top dry well**

CIRCUIT #1

CIRCUIT #1	LOADING
208 V / 240 V	
L1	17.6 20.3
L2	15.9 18.3
L3	9.4 10.8

**NOTE: CASE MUST BE GROUNDED**

**5152W @ 208VAC**  
**6845W @ 240VAC**

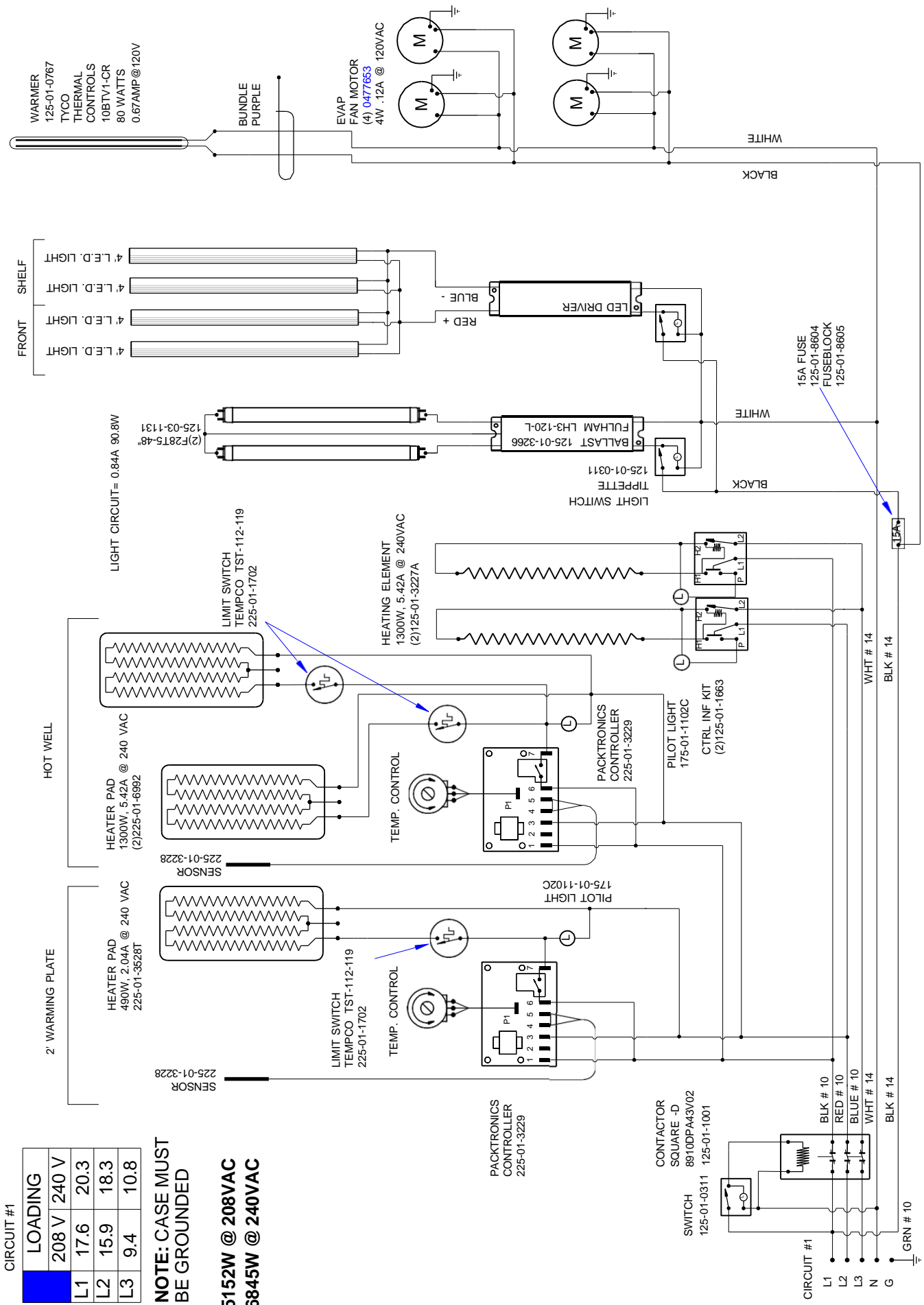

-208 / 240 VAC - 60 Hz.

REVISIONS:  
# DESCRIPTION:

B	Placed fans and heater tape before light circuit fuse	DATE: 3/22/10	BY: JR
C	ECN-CAP-0006456 Changed Front to LED Lights	DATE: 2/13/17	BY: CB

DRAWN BY: JESSE RIOS

CHECKED BY: DATE: 12/22/08

PROJECT TITLE: R3

PRODUCTION ORDER #: 521734  
FILE LOCATION:

DRAWING TITLE: R3H-8-REM

DRAWING #: W1800192

CIRCUIT #2

LOADING	
120 V	
L1 15.0	

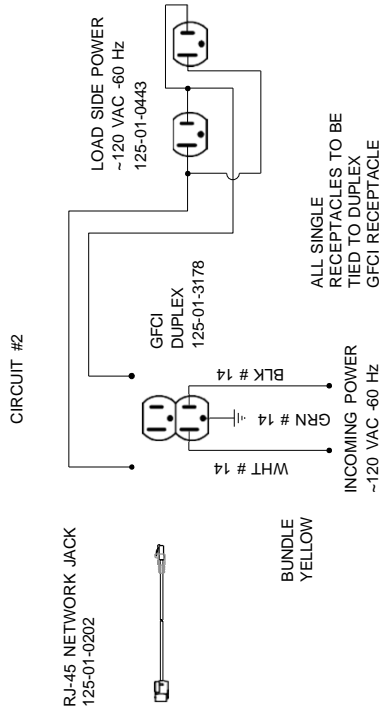

REVISIONS:

#	DESCRIPTION:
B	Placed fans and heater taps before light circuit fuse

DRAWN BY: JESSE RIOS	CHECKED BY:	DATE: 12/22/08
PRODUCTION ORDER #: 521734	FILE LOCATION:	

PROJECT TITLE: R3	DRAWING #: W1800192
DRAWING TITLE: R3H-8-REM	

CIRCUIT #1

LOADING	208 V	240 V
L1	21.6	25.0
L2	19.2	22.1

**NOTE: CASE MUST BE GROUNDED**

**4493W @ 208VAC**  
**6000W @ 240VAC**

WARMER  
FOIL TAPE  
1H36822550  
200 WATTS @ 115V  
1.74 AMPS

TOP LIGHT CIRCUIT= 0.74A 80.4W

TOP

TOP

HEATER PAD  
1300W, 5.42A @ 240 VAC  
225-01-6992

HEATER PAD  
1900W, 7.92A @ 240 VAC  
225-01-6991

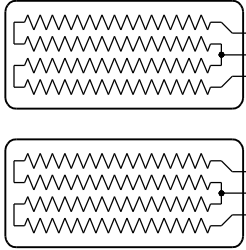

SENSOR  
225-01-3228

TEMP. CONTROL

PACKETRONICS  
CONTROLLER  
225-01-3229

LED DRIVER

BALLAST  
FULHAM LH4-120-L  
125-01-3267

LED DRIVER

EVAP  
FAN MOTOR 12W  
(4) 3174935 .07A EA

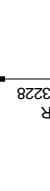
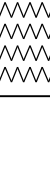
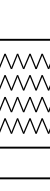
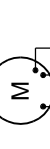

-208 / 240 VAC - 60 HZ.

REVISIONS:

#	DESCRIPTION:	DATE:	BY:
B	ECN-CAP-0006456 Changed Front To LED Lights	2/13/17	CB
C	ECN-CAP-0012699 Changed Anit-Sweat Heaters	6/8/18	CB
D	ECN-COD-0018141 Changed Fan Motor	7/5/23	CB

DRAWN BY: JESSE RIOS  
CHECKED BY: DATE: 2/5/10  
PRODUCTION ORDER #: 622194  
FILE LOCATION:

PROJECT TITLE: R3  
DRAWING TITLE:  
CR3H-8-REM, 6' UPPER HOT WELL

CIRCUIT #2

LOADING	
120 V	
L1 15.0	

**NOTE: CASE MUST BE GROUNDED**

NOTE FOR GFCI PROTECTION: IF MORE THAN ONE SINGLE RECEPTACLE IS USED IN CONJUNCTION WITH A GFCI DUPLEX RECEPTACLE "DOWNSTREAM" ON THE LOAD SIDE, THE SUM OF ALL RECEPTACLES SHOULD NOT BE MORE THAN 15A

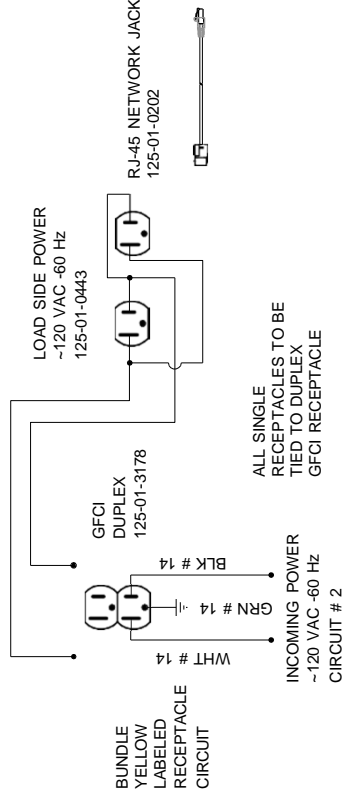

REVISIONS:

#	DESCRIPTION:	DATE:	BY:
B	ECN-CAP-0006456 Changed Front To LED Lights	2/13/17	CB
C	ECN-CAP-0012699 Changed Anti-Sweat Heaters	6/8/18	CB
D	ECN-COD-0018141 Changed Fan Motor	7/5/23	CB

DRAWN BY: JESSE RIOS  
 CHECKED BY: DATE: 2/5/10  
 PRODUCTION ORDER #: 622194  
 FILE LOCATION:

PROJECT TITLE: R3

DRAWING #: W1800196

DRAWING TITLE:  
**CR3H-8-REM, 6' UPPER HOT WELL**

CIRCUIT #1

LOADING	
120V	
±0	

LIGHT CIRCUIT 33A 352W

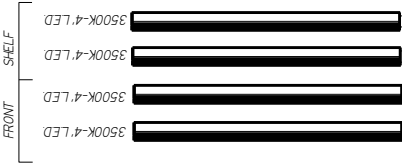

WARMER  
FOIL TAPE  
1H96622550  
200 WATTS @ 115V  
1.74 AMPS

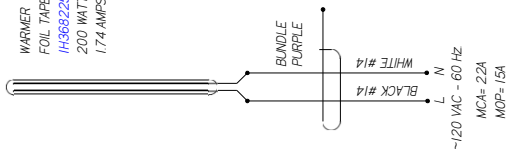

OPTIONAL

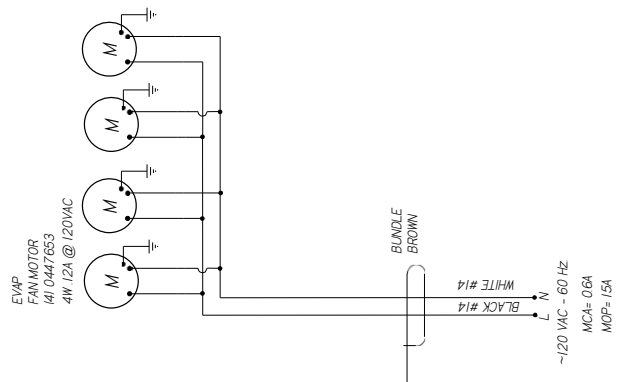
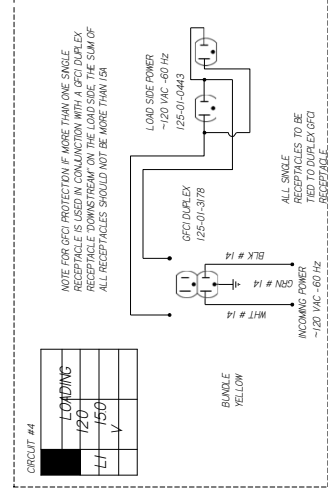

REV	ECN	DATE	REVISION DESCRIPTION	REV BY	CHKD BY	APPR BY
A	803263	2014/03/24	NEW ORDER	CB	CB	CB
B	930249	2015/07/15	CHANGED TERMINAL BLOCK ON CIRCUIT 2	CB	CB	CB
C	EDW-CAP-002699	2018/08/01	CHANGED AUTO-SWEAT HEATER	CB	CB	CB

REVISION HISTORY

MATERIAL - N/A  
DATE DRAWN - 3/24/14  
DRAWN BY - CRAIG BOOREY  
REVIEWED BY - CRAIG BOOREY  
APPROVED BY - CRAIG BOOREY  
UNLESS OTHERWISE SPECIFIED DIMENSIONS ARE IN INCHES  
TOLERANCES ARE:  
DECIMALS XX ±0.3, XXX ±0.10  
ANGLES ± 2°

**HUSSMANN**  
DIAGRAM=R3-HD-  
8-SH-4SW-4HW-R  
W6600117 | C

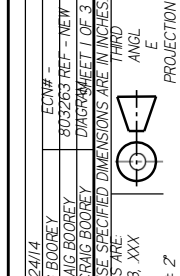

NOTES:  
CASE MUST BE GROUNDED

CIRCUIT #2

LDING	240V	240V
L1	208V	208V
L2	208V	208V
L3	208V	208V

5346W @ 208VAC  
7104W @ 240VAC

REVISION HISTORY			
REV	ECN	DATE	DESCRIPTION
A	803263	2014/03/24	NEW DRAWING
B	930249	2015/07/15	CHANGED TERMINAL BLOCK ON CIRCUIT 2
C	EDN-CAP-0002699	2018/08/01	CHANGED AUTO-SWEAT HEATER

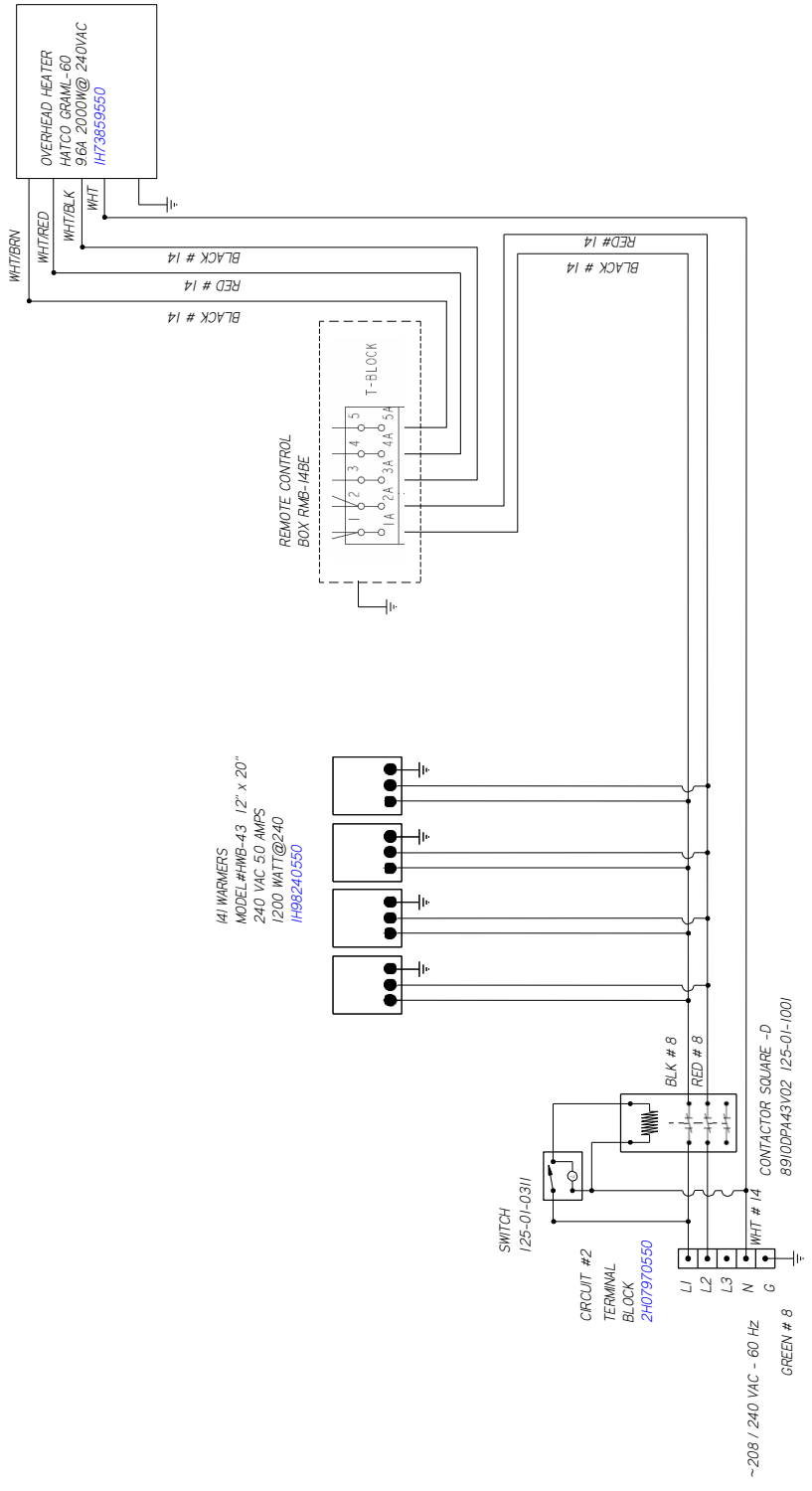

141 WARMERS  
MODEL #HMB-43 12" x 20"  
240 VAC 5.0 AMPS  
1200 WATT@240  
IH962406550

**HUSSMANN**  
DIAGRAM=R3-HD-  
8- SH-4SW-4HW-R

MATERIAL - N/A  
DATE DRAWN - 3/24/14  
DRAWN BY - CRAIG BOOREY  
REVIEWED BY - CRAIG BOOREY  
APPROVED BY - CRAIG BOOREY  
UNLESS OTHERWISE SPECIFIED DIMENSIONS ARE IN INCHES  
TOLERANCES ARE:  
DECIMALS .XX ±0.03 .XXX  
±0.0

ECN# - 803263 REF - NEW  
DIAGRAM SHEET 2 OF 3  
THIRD ANGL  
E  
PROJECTION

W6600117 | C

NOTES:  
CASE MUST BE GROUNDED

REVISION HISTORY			
REV	ECN	DATE	DESCRIPTION
A	803263	2014/03/24	NEW DRAWING
B	930249	2015/07/15	CHANGED TERMINAL BLOCK ON CIRCUIT 2
C	EDN-CAP-002699	2018/08/01	CHANGED AUTO-SWEAT HEATER

CIRCUIT #3	INDG
	208V
	240
	100
	100
	100

180W @ 208VAC  
2400W @ 240VAC

141 SOLIP WARMERS  
MODEL #HWB-110T  
2.5 AMPS @240V  
600WATTS  
IH33446550

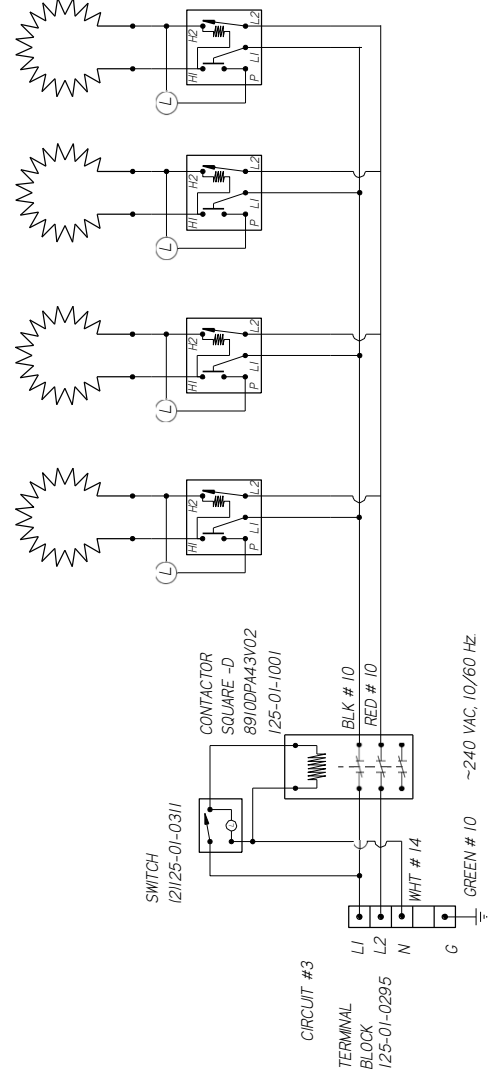

SWITCH 121125-01-0311  
CONTACTOR SQUARE-D 8910DP443V02 125-01-1001  
TERMINAL BLOCK 125-01-0295  
L1 L2 N G  
BLK # 10 RED # 10 WHT # 14 GREEN # 10  
-240 VAC, 10/60 Hz

**HUSSMANN**  
DIAGRAM-R3-HD-  
8- SH-4SW-4HW-R

MATERIAL - N/A  
DATE DRAWN - 3/24/14  
DRAWN BY - CRAIG BOOREY  
REVIEWED BY - CRAIG BOOREY  
APPROVED BY - CRAIG BOOREY  
UNLESS OTHERWISE SPECIFIED DIMENSIONS ARE IN INCHES.  
TOLERANCES ARE:  
DECIMALS .XX ±0.3, .XXX ±0.10  
ANGLES ± 2°

ECN# - 803263 REF - NEW  
DIAGRAM SHEET 3 OF 3  
THIRD ANGL PROJECTION

W6600117 | C

NOTES:  
CASE MUST BE GROUNDED

CIRCUIT #1

LOADING	208 V	240 V
L1	22.7	26.2
L2	20.9	24.2
L3	9.4	10.8

**NOTE: CASE MUST BE GROUNDED**

**5704W @ 208VAC**  
**7593W @ 240VAC**

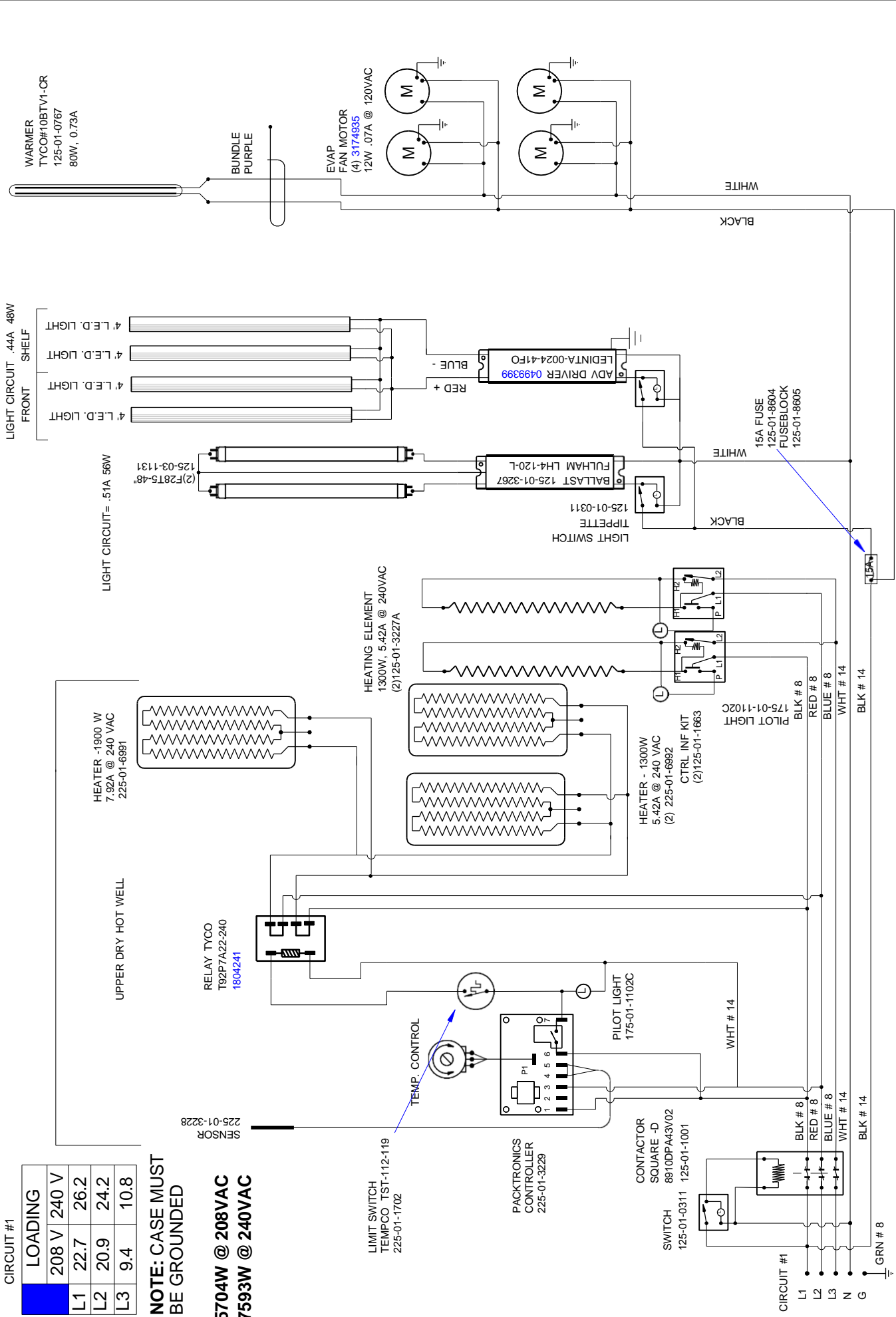

REVISIONS:	DATE:	BY:	DESCRIPTION:
H	6/1/18	CB	ECN-CAP-0012699 Changed Anti-Sweat Heater
I	5/20/21	CB	ECN-COD-13665 Changed A.S.Hr
J	7/5/23	CB	ECN-COD-0018141 Changed Fan Motor

-208 / 240 VAC - 60 Hz.

CIRCUIT #2

LOADING	
120 V	
L1 15.0	

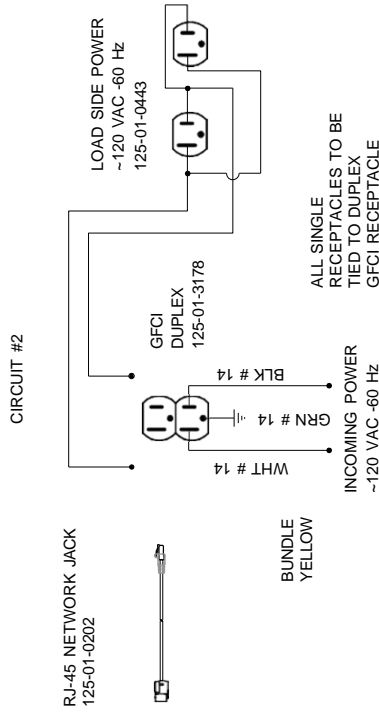

REVISIONS:

#:	DESCRIPTION:	DATE:	BY:
H	ECN-CAP-0012699 Changed Anti-Sweat Heater	6/11/18	CB
I	ECN-COD-13665 Changed A.S.Hr.	5/20/21	CB
J	ECN-COD-0018141 Changed Fan Motor	7/5/23	CB

DRAWN BY: JESSE RIOS	CHECKED BY:	DATE: 6/5/08
PRODUCTION ORDER #: 621533	FILE LOCATION:	

CIRCUIT #1

LOADING	208 V	240 V
L1	29.9	34.5
L2	31.6	36.5
L3	17.9	20.7

**NOTE: CASE MUST BE GROUNDED**

**9535W @ 208VAC**  
**12706W @ 240VAC**

LIMIT SWITCH  
TEMPCO TST-112-119  
225-01-1702

PACKTRONICS  
CONTROLLER  
225-01-3229

CONTACTOR  
SQUARE -D  
8910DPA43V02  
125-01-1001

SWITCH  
125-01-0311

RCUIT #1  
L1  
L2  
L3  
N  
G

GRN # 8  
-208 / 240 VAC - 60 Hz.

HEATER -1900 W  
7.92A @ 240 VAC  
(2) 225-01-6991

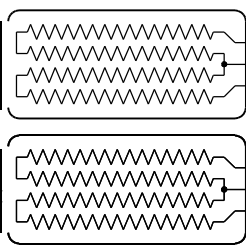

CONTACTOR  
SQUARE -D  
8910DPA43V02  
125-01-1001

HEATING ELEMENT  
1760W, 7.33A @ 240VAC  
(2) 125-01-1002A

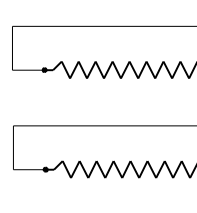

TEMP. CONTROL

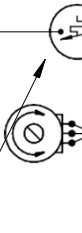

PACKTRONICS  
CONTROLLER  
225-01-3229

CONTACTOR  
SQUARE -D  
8910DPA43V02  
125-01-1001

SWITCH  
125-01-0311

PILOT LIGHT  
175-01-1102C



HEATER - 1300W  
5.42A @ 240 VAC  
(1) 225-01-6992



CTRL INF KIT  
(3) 125-01-1663

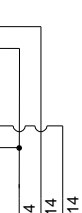
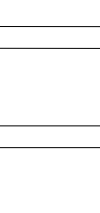

15A FUSE  
125-01-8604  
FUSEBLOCK  
125-01-8605

BOTTOM SECTION

LED LIGHT CIRCUIT= .46A 50W

OPTIONAL LIGHTED SHELVES  
5 L.E.D. LIGHT  
5 L.E.D. LIGHT  
5 L.E.D. LIGHT  
5 L.E.D. LIGHT

T-5 LIGHT CIRCUIT= .665A 70W

TOP SECTION  
(2) F35T5-60'  
(2) F35T5-60'

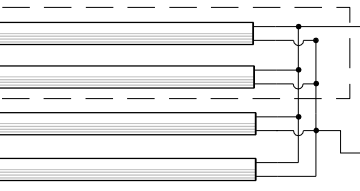

WARMER  
FOIL TAPE  
1H44314550  
250 WATTS @ 115V  
2.2 AMPS

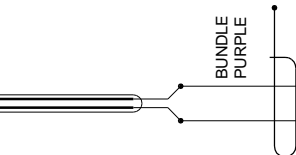

EVAP  
FAN MOTOR  
(4) 3172574  
12W .08A @ 120VAC

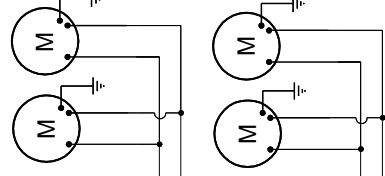

D	ECN-CAP-0012699	CHANGED ANTI-SWEAT HEATER	6/11/18	CB
E	ECN-COD-0018141	CHANGED FAN MOTOR	7/5/23	CB
F	ECN-COD-00181715	NEW FAN MOTOR	10/30/23	CB

CIRCUIT #2

LOADING	
120 V	
L1 15.0	

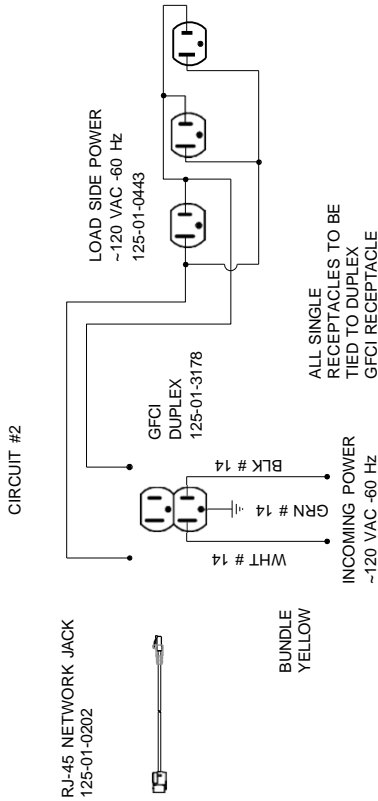

REVISIONS:

#	DESCRIPTION:	DATE:	BY:
D	ECN-CAP-0012699 CHANGED ANTI-SWEAT HEATER	6/11/18	CB
E	ECN-COD-0018141 CHANGED FAN MOTOR	7/5/23	CB
F	ECN-COD-0018715 NEW FAN MOTOR	10/30/23	CB

DRAWN BY: CRAIG BOOREY	PROJECT TITLE: R3
CHECKED BY:	DATE: 9/4/12
PRODUCTION ORDER #: 565416	
FILE LOCATION:	

CIRCUIT #1

LOADING	208 V   240 V
L1	25.1
L2	27.8
L3	25.7

**NOTE: CASE MUST BE GROUNDED**

**9439W @ 208VAC**  
**12553W @ 240VAC**

LIMIT SWITCH  
TEMPCO TST-112-119  
225-01-1702

PACKTRONICS  
CONTROLLER  
225-01-3229

CONTACTOR  
SQUARE -D  
8910DPA43V02  
125-01-1001

SWITCH  
125-01-0311

CIRCUIT #1  
L1  
L2  
L3  
N  
G

GRN # 8  
-208 / 240 VAC - 60 Hz.

HEATER -1900 W  
7.92A @ 240 VAC  
(2) 225-01-6991

UPPER DRY HOT WELL

CONTACTOR  
SQUARE -D  
8910DPA43V02  
125-01-1001

LIGHT CIRCUIT= 1.0A 108.2W

HEATING ELEMENT  
1300W, 5.42A @ 240VAC  
(3) 125-01-3227A

TOP SECTION

FRONT SECTION

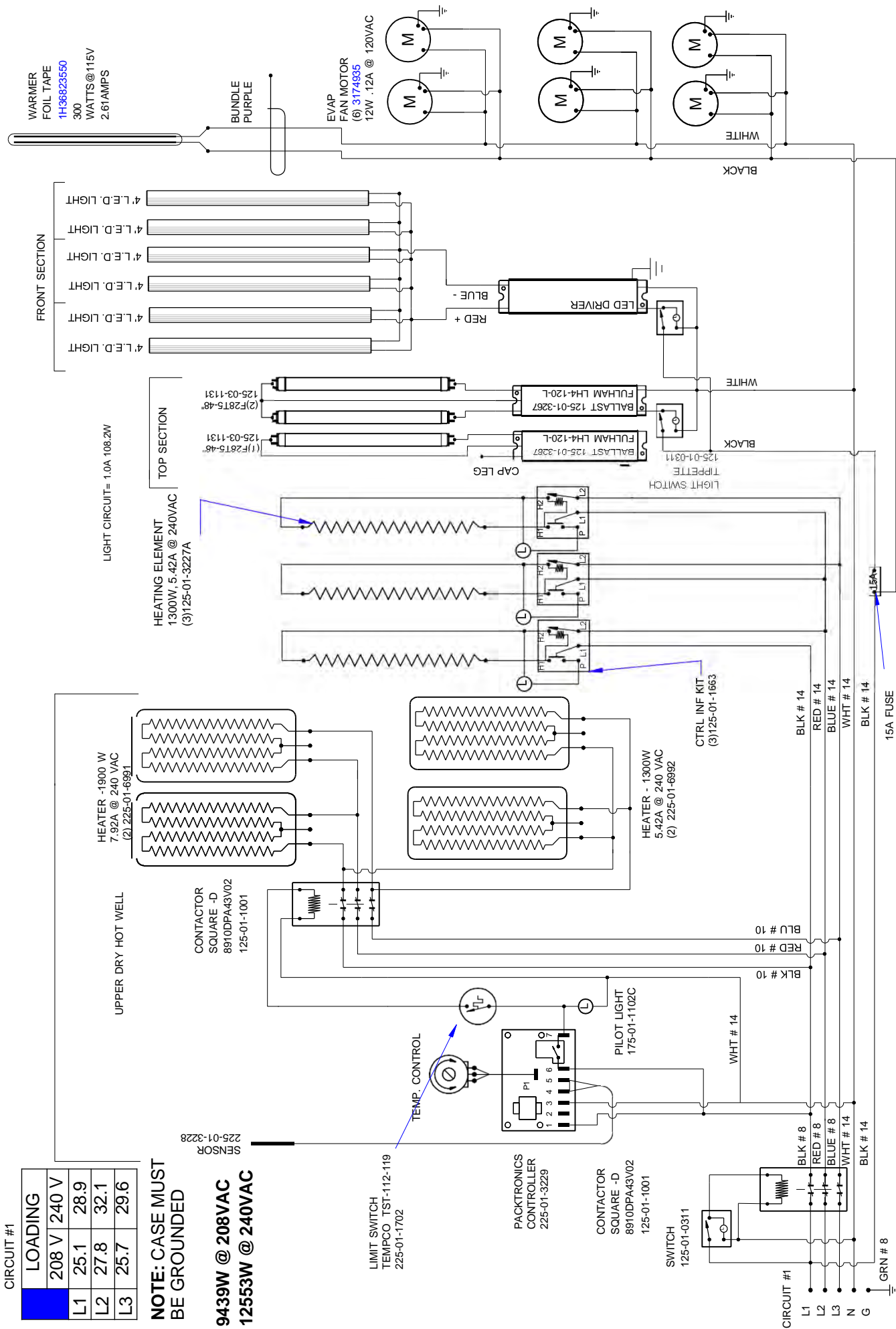

WARMER  
FOIL TAPE  
1H36823550  
300  
WATTS@115V  
2.61AMPS

BUNDLE  
PURPLE

EVAP  
FAN MOTOR  
(6) 3174935  
12W .12A @ 120VAC

BLACK  
WHITE

REVISIONS:

#	DESCRIPTION:	DATE:	BY:
C	ECN-CAP-0006456 Changed Front to LED Lights	2/13/17	CB
D	ECN-CAP-0012699 Changed Anti-Sweat Heater	6/11/18	CB
E	ECN-COD-0018141 Changed Fan Motor	7/5/23	CB

DRAWN BY: MATT GRAMATA  
CHECKED BY: DATE: 2/17/11  
PROJECT TITLE: R3  
PRODUCTION ORDER #: 522862  
FILE LOCATION:

CIRCUIT #2

LOADING	
120 V	
L1 15.0	

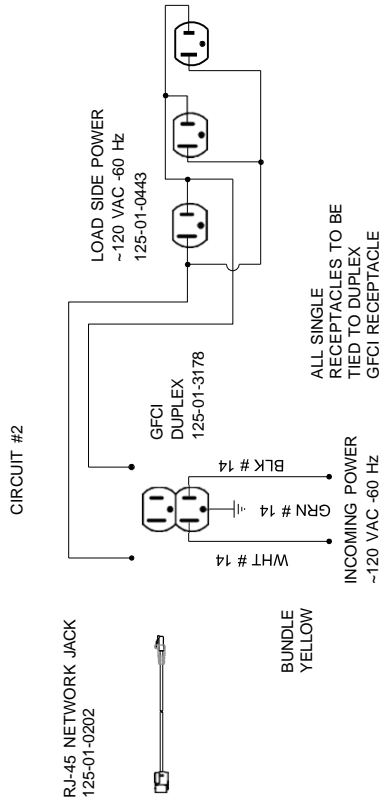

REVISIONS:

#	DESCRIPTION:
C	ECN-CAP-0006456 Changed Front to LED Lights
D	ECN-CAP-0012699 Changed Anti-Sweat Heater
E	ECN-COD-0018141 Changed Fan Motor

DATE:	BY:
2/13/17	CB
6/11/18	CB
7/5/23	CB

DRAWN BY:	MATT GRAMATA
CHECKED BY:	DATE: 2/17/11
PRODUCTION ORDER #:	522862
FILE LOCATION:	

PROJECT TITLE: R3

DRAWING TITLE:

R3H-12-REM With top dry well

DRAWING #: W1800199

REV	ECN	DATE	REVISION HISTORY	REV BY	CHKD BY	APPR BY
1	781433	2014/01/14	NEW DIAGRAM	CB	CB	CB
2	ECN-CAP-0012699	2018/06/11	CHANGED ANTI-SWEAT HEATER	CB	CB	CB
3	ECN-COD-0018141	2023/07/05	CHANGED FAN MOTOR	CB	CB	CB

CIRCUIT #1 LOADING	208V	240V
L1	20A	20A
L2	10A	10A
L3	10A	10A
N	10A	10A
G	10A	10A

6413W @ 208VAC  
8521W @ 240VAC

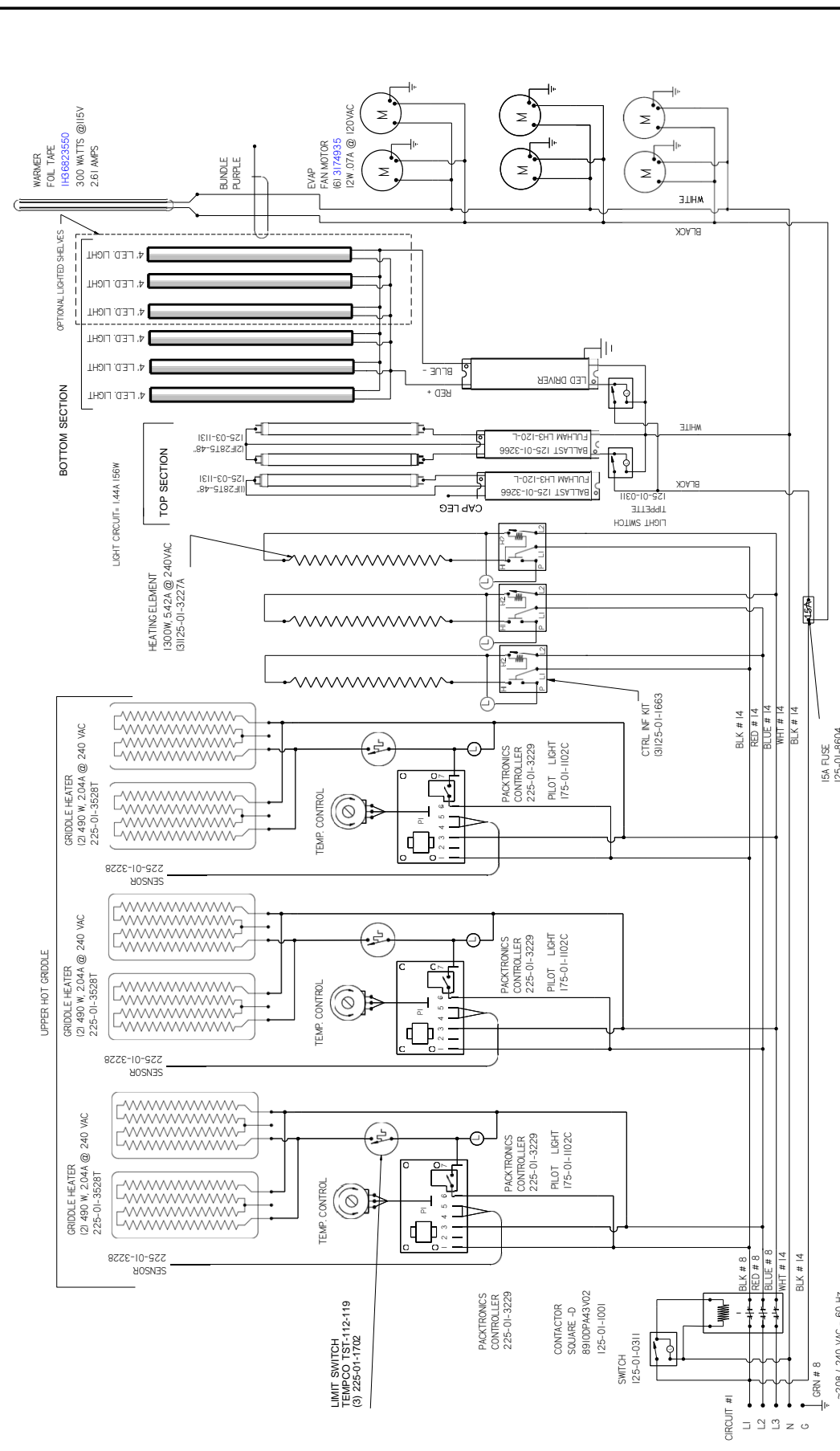

**MATERIAL - N/A**  
 DATE DRAWN - 1/14/14  
 DRAWN BY - CRAIG BOOREY  
 REVIEWED BY - CRAIG BOOREY  
 APPROVED BY - CRAIG BOOREY  
 UNLESS OTHERWISE SPECIFIED DIMENSIONS ARE IN INCHES  
 TO LEANING ARTS  
 THIRD  
 DECIMALS .XX +03 .XXX  
 ±0.0  
 ANGLES ± 2°

**HUSSMANN**  
**DIAGRAM-R3-H-12-R**  
 ECN# - 781433 REF - NEW  
 DIAGRAHSHEET LOE I  
 PROJECTION  
 ANGL  
 E

W6600113 | C

NOTES:  
 CASE MUST BE GROUNDED

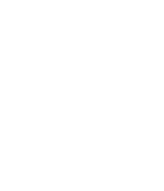

CIRCUIT #1

LOADING	208 V   240 V
L1	27.1   31.3
L2	27.8   32.1
L3	25.7   29.6

**NOTE: CASE MUST BE GROUNDED**

**9679W @ 208VAC**  
**12886W @ 240VAC**

LIMIT SWITCH  
TEMPCO TST-112-119  
225-01-1702

PACKTRONICS  
CONTROLLER  
225-01-3229

CONTACTOR  
SQUARE - D  
8910DPA43V02  
125-01-1001

SWITCH  
125-01-0311

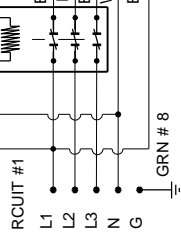

HEATER - 1900 W  
7.92A @ 240 VAC  
(2) 225-01-6991

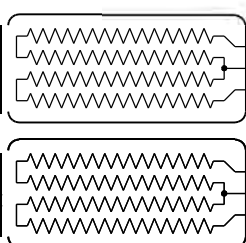

HEATER - 1300W  
5.42A @ 240 VAC  
(2) 225-01-6992

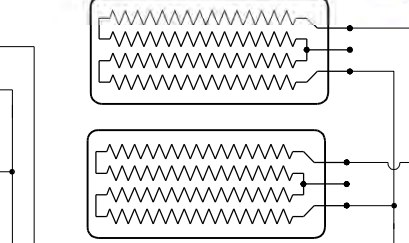

CTRL INF KIT  
(3) 125-01-1663

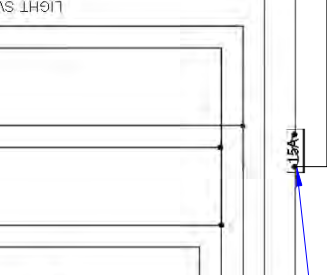

HEATING ELEMENT  
1300W, 5.42A @ 240VAC  
(3) 125-01-3227A

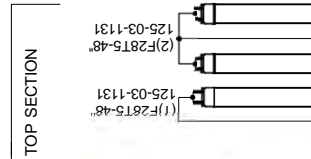

BOTTOM SECTION

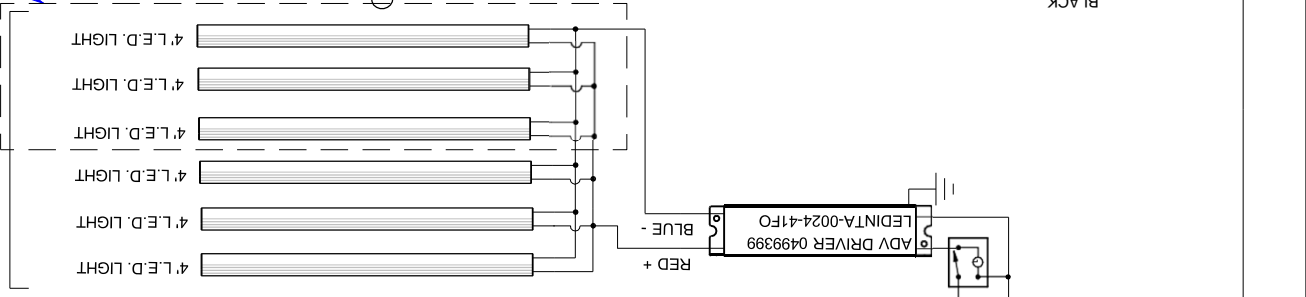

OPTIONAL LIGHTED SHELVES

WARMER  
1H36823550  
FOIL HTR TAPE  
2.5A 300WATTS

LIGHT CIRCUIT= 1.44A 156W

TOP SECTION  
CAP LEG  
FULHAM LH3-120-L  
BALLAST 125-01-3266  
125-03-1131 (1F) 2815-48  
FULHAM LH3-120-L  
BALLAST 125-01-3266  
125-03-1131 (2F) 2815-48

CONTACTOR  
SQUARE - D  
8910DPA43V02  
125-01-1001

PILOT LIGHT  
175-01-1102C

TEMP. CONTROL

UPPER DRY HOT WELL

HEATER - 1900 W  
7.92A @ 240 VAC  
(2) 225-01-6991

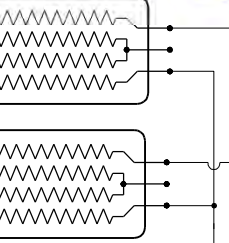

HEATER - 1300W  
5.42A @ 240 VAC  
(2) 225-01-6992

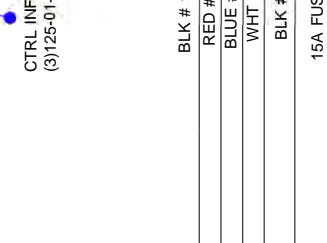

CTRL INF KIT  
(3) 125-01-1663

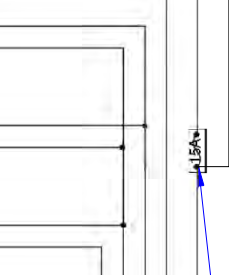

HEATING ELEMENT  
1300W, 5.42A @ 240VAC  
(3) 125-01-3227A

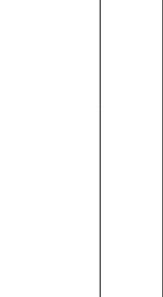
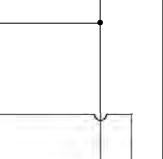

WARMER  
1H36823550  
FOIL HTR TAPE  
2.5A 300WATTS

CIRCUIT #2

LOADING	
120 V	
L1 15.0	

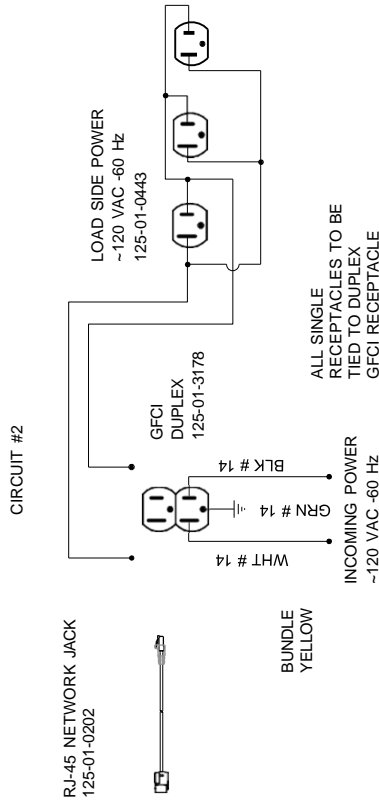

REVISIONS:

#	DESCRIPTION:	DATE:	BY:
B	ECN-CAP-0012698 CHANGED ANTI-SWEAT HEATER	6/1/18	CB
C	ECN-COD-0018141 CHANGED FAN MOTOR	7/5/23	CB

DRAWN BY: CRAIG BOOREY	PROJECT TITLE: R3
CHECKED BY:	DATE: 1/11/12
PRODUCTION ORDER #: 523364	DRAWING TITLE:
FILE LOCATION:	R3H-12-REM With top dry well

## 12. Troubleshooting

Problem	Possible Cause	Possible Solution
<b>Product not holding temperature.</b>	Ambient conditions may be affecting the case operation.	Check case position in store. Is the case located near an open door, window, electric fan or air conditioning vent that may cause air currents? Case must be located minimum 15 Ft away from doors or windows. Cases are designed to operate at 55% Relative humidity and a temperature of 75°F.
	Unit not preheated.	Preheat case before loading product.
	Heat settings too low	Adjust shelf/griddle control setting.
	Low voltage.	Using volt meter make sure line voltage matches serial plate voltage.
	Product held too long	Hold product for recommended time.
	Product not placed correctly in case.	Place product in case per recommendations.
	Product not hot when placed in case.	Place prepackaged hot food in case.
<b>No shelf heat.</b>	Faulty shelf heater.	Check and replace if necessary.
	Faulty control.	Check and replace if necessary.
	Loose wiring on heater.	Check wiring/electrical connections.
	Temperature setting "Off".	Increase shelf heat setting.
<b>No griddle heat.</b>	Faulty griddle heater.	Check and replace if necessary.
	Faulty control.	Check and replace if necessary.
	Loose wiring on heater.	Check wiring/electrical connections.
	Temperature setting "Off".	Increase griddle heat setting.
<b>No hot/soup well heat.</b>	Faulty hot/soup well.	Check and replace if necessary.
	Loose wiring on hot/soup well.	Check wiring/electrical connections.
<b>Main Power switch on but case is inoperative.</b>	Open Circuit.	Check to see that cord is plugged in if plug is provided. Check wiring/electrical connections for hard wired cases. Check line voltage. Check power switch and replace if defective.
<b>Condensation on glass.</b>	Ambient conditions may be affecting the case operation.	Check case position in store. Is the case located near an open door, window, electric fan or air conditioning vent that may cause air currents? Case must be located minimum 15 Ft away from doors or windows. Cases are designed to operate at 55% Relative humidity and a temperature of 75°F.
	Inadequate air circulation.	Check if air sweep fans are functioning, check electrical connections.
	There is not enough heat provided in the airflow.	Check if air sweep heater is functioning, check electrical connections.
	There are glass gaps on the side of the case.	See glass adjustment section.
	Glass is not completely shut.	Close glass correctly.
	Calrods may not be working.	Check calrod operation.
	Well control setting is too high.	Check that well setting is not above "7" on control knob.

## Troubleshooting (Cont'd)

Problem	Possible Cause	Possible Solution
<b>Large gap is visible on bottom of front glass or glass can't be opened because it is too low.</b>	Glass Height adjusters need to be adjusted.	See Glass Adjustment section.
<b>Large gaps are visible in between glass panels or glass rubs against end panel.</b>	Glass/glass clamp assembly needs to be adjusted.	See Glass Adjustment section.
<b>Front glass does not stay open and falls closed.</b>	Glass shock/piston may need to be replaced.	Case should be serviced by a qualified service technician.
<b>Lights do not come on.</b>	Ballast/light socket wiring.	Check electrical connections. See Electrical Section and check wiring diagram.
	Ballast needs to be replaced.	Case should be serviced by a qualified service technician. See Electrical Section.
	Lamp socket needs to be replaced.	Case should be serviced by a qualified service technician.
	Lamp needs to be replaced.	See Maintenance Section.
	Light Switch needs to be replaced.	Case should be serviced by a qualified service technician.
<b>PR1 Error Code</b>	Faulty controller or sensor	Unplug sensor from plug connection: If PR1 code remains, then the controller is faulty; if the PR1 code disappears, then the sensor is faulty.  Case should be serviced by a qualified Hatco service technician. Call the 24 Hour Tech Hotline (800) 558-0607

# 13. Appendices

## Appendix A. - Temperature Guidelines - Refrigerated

The refrigerators should be operated according to the manufacturer's published engineering specifications for entering air temperatures for specific equipment applications. Table 1 shows the typical temperature of the air entering the food zone one hour before the start of defrost and one hour after defrost for various categories of refrigerators. Refer to Appendix C for Field Evaluation Guidelines.

Type of Refrigerator	Typical Entering Air Temperature
<b>I. OPEN DISPLAY</b>	
A. Non frozen:	
1) Meat	28°F
2) Dairy/Deli	32°F
3) Produce	
a. Processed	36°F
b. Unprocessed	45°F
B. Frozen	0°F
C. Ice Cream	-5°F
<b>II. CLOSED DISPLAY</b>	
A. Non frozen:	
1) Meat	34°F
2) Dairy/Deli	34°F
3) Produce	
a. Processed	36°F
b. Unprocessed	45°F
B. Frozen	0°F
C. Ice Cream	-5°F

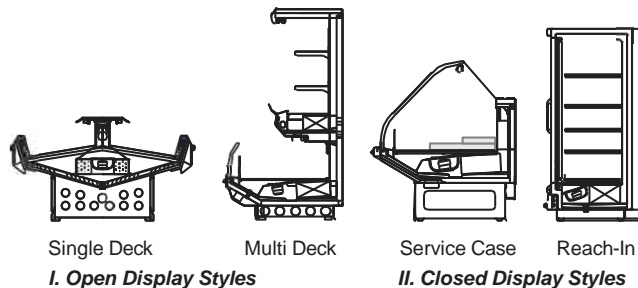

1. The installer is responsible for following the installation instructions and recommendations provided by Hussmann for the installation of each individual type refrigerator.
2. Refrigeration piping should be sized according to the equipment manufacturer's recommendations and installed in accordance with normal refrigeration practices. Refrigeration piping should be insulated according to Hussmann's recommendations.
3. A clogged waste outlet blocks refrigeration. The installer is responsible for the proper installation of the system which dispenses condensate waste through an air gap into the building indirect waste system.
4. The installer should perform a complete start-up evaluation prior to the loading of food into the refrigerator, which includes such items as:
  - a) Initial temperature performance, Coils should be properly fed with a refrigerant according to manufacturer's recommendations.
  - b) Observation of outside influences such as drafts, radiant heating from the ceiling and from lamps. Such influence should be properly corrected or compensated for.
  - c) At the same time, checks should be made of the store dry-bulb and wet-bulb temperatures to ascertain that they are within the limits prescribed by Hussmann.
  - d) Complete start-up procedures should include checking through a defrost to make certain of its adequate frequency and length without substantially exceeding the actual needs. This should include checking the electrical or refrigerant circuits to make sure that defrosts are correctly programmed for all the refrigerators connected to each refrigeration system.
  - e) Recording instruments should be used to check performance.

**Hot**

1.0 Hot cases are tested to maintain all hot food at 140° - 150°F. These cases are not designed to heat up or cook food. It is the user's responsibility to stock the hot food cases immediately after the cooking of the food with a pulp temperature of at least 150° to 160°F.

## Appendix B. - Application Recommendations - Refrigerated

1.0 Temperature performance is critical for controlling bacteria growth. Therefore, the following recommendations are included in the standard. They are based on confirmed field experience over many years.

**Hot**

- 1.0 The installer should perform a complete start-up evaluation prior to the loading of food into the hot food case, which includes such items as:
  - a) Initial temperature performance, Griddles and Hot Wells.
  - b) Observation of outside influences such as drafts, radiant heating from the ceiling and from lamps. Such influence should be properly corrected or compensated for.
  - c) Complete start-up procedures should include
    1. Heat I display lamps are lighting

## Appendices (Cont'd)

2. Indicator lamps on control panel(s) are working
3. Auto-fill is functioning properly (Service cases)
4. Hot Griddles are functioning.

### Appendix C. - Field Recommendations - Refrigerated

#### Recommendations for field evaluating the performance of retail food refrigerators and hot cases

1. The most consistent indicator of display refrigerator performance is temperature of the air entering the product zone (see Appendix A). In practical use, the precise determination of return air temperature is extremely difficult. Readings of return air temperatures will be variable and results will be inconsistent. The product temperature alone is not an indicator of refrigerator performance.

**NOTE:** Public Health will use the temperature of the product in determining if the refrigerator will be allowed to display potentially hazardous food. For the purpose of this evaluation, product temperature above the FDA Food Code 1993 temperature for potentially hazardous food will be the first indication that an evaluation should be performed. It is expected that all refrigerators will keep food at the FDA Food Code 1993 temperature for potentially hazardous food.

1. The following recommendations are made for the purpose of arriving at easily taken and understood data which, coupled with other observations, may be used to determine whether a display refrigerator is working as intended:
  - a) **INSTRUMENT** - A stainless steel stem-type thermometer is recommended and it should have a dial a minimum of 1 inch internal diameter. A test thermometer scaled only in Celsius or dually scaled in Celsius and Fahrenheit shall be accurate to 1°C (1.8°F). Temperature measuring devices that are scaled only in Fahrenheit shall be accurate to 2°F. The thermometer should be checked for proper calibration. (It should read 32°F when the stem is immersed in an ice water bath).
  - b) **LOCATION** - The probe or sensing element of the thermometer should be located in the airstream where the air first enters the display or storage area, and not more than 1 inch away from the surface and in the center of the discharge opening.
  - c) **READING** - It should first be determined that the refrigerator is refrigerating and has operated at least one hour since the end of the last defrost period. The thermometer

reading should be made only after it has been allowed to stabilize, i.e., maintain a constant reading.

- d) **OTHER OBSERVATIONS** - Other observations should be made which may indicate operating problems, such as unsatisfactory product, feel/appearance.
- e) **CONCLUSIONS** - In the absence of any apparent undesirable conditions, the refrigerator should be judged to be operating properly. If it is determined that such condition is undesirable, i.e., the product is above proper temperature, checks should be made for the following:
  1. Has the refrigerator been loaded with warm product?
  2. Is the product loaded beyond the "Safe Load Line" markers?
  3. Are the return air ducts blocked?
  4. Are the entering air ducts blocked?
  5. Is a dumped display causing turbulent air flow and mixing with room air?
  6. Are spotlights or other high intensity lighting directed onto the product?
  7. Are there unusual draft conditions (from heating/air-conditioning ducts, open doors, etc.)?
  8. Is there exposure to direct sunlight?
  9. Are display signs blocking or diverting airflow?
  10. Are the coils of the refrigerator iced up?
  11. Is the store ambient over 75°F, 55% RH as set forth in ASHRAE Standard 72 and ASHRAE Standard 117?
  12. Are the shelf positions, number, and size other than recommended by Hussmann?
  13. Is there an improper application or control system?
  14. Is the evaporator fan motor/blade inoperative?
  15. Is the defrost time excessive?
  16. Is the defrost termination, thermostat (if used) set too high?
  17. Are the refrigerant controls incorrectly adjusted?
  18. Is the air entering the condenser above design conditions? Are the condenser fins clear of dirt, dust, etc.?
  19. Is there a shortage of refrigerant?
  20. Has the equipment been modified to use replacements for CFC-12, CFC-502 or other refrigerant? If so,

## Appendices (Cont'd)

have the modifications been made in accordance with the recommendations of the equipment manufacturer? Is the refrigerator charged with the proper refrigerant and lubricant? Does the system use the recommended compressor?

### Hot

1. The most consistent indicator of display hot case performance is temperature of the product itself.

**NOTE:** Public Health will use the temperature of the product in determining if the hot case will be allowed to display potentially hazardous food. For the purpose of this evaluation, product temperature above the FDA Food Code 1993 temperature for potentially hazardous food will be the first indication that an evaluation should be performed. It is expected that all hot cases will keep food at the FDA Food Code 1993 temperature to prevent the sale of potentially hazardous food.

1. The following recommendations are made for the purpose of arriving at easily taken and understood data which, coupled with other observations, may be used to determine whether a display refrigerator is working as intended:
  - a) **INSTRUMENT** - A stainless steel stem-type thermometer is recommended and it should have a dial a minimum of 1 inch internal diameter. A test thermometer scaled only in Celsius or dually scaled in Celsius and Fahrenheit shall be accurate to 1°C (1.8°F). Temperature measuring devices that are scaled only in Fahrenheit shall be accurate to 2°F. The thermometer should be checked for proper calibration. (It should read 32°F when the stem is immersed in an ice water bath).
  - b) **LOCATION** - The thermometer must be inserted into the food itself to acquire proper food pulp temperature.
  - c) **READING** - The thermometer reading should be made only after it has been allowed to stabilize, i.e., maintain a constant reading. Loading Product: Cases should be allowed to heat up for one hour before product is loaded. Temperature adjustments: Allow 4 hours after adjustment has been made before testing pulp temperature of product
  - d) **OTHER OBSERVATIONS** - Other observations should be made which may indicate operating problems, such as unsatisfactory product, feel/appearance.

## Appendix D. - Recommendations to User - Refrigerated

1. Hussmann Corporation provides instructions and recommendations for proper periodic cleaning. The user will be responsible for such cleaning, including the cleaning of low temperature equipment within the compartment and the cooling coil area(s). Cleaning practices, particularly with respect to proper refrigerator unloading and warm-up, must be in accordance with applicable recommendations.
  1. Cleaning of non frozen food equipment should include a weekly cleaning of the food compartment as a minimum to prevent bacteria growth from accumulating. Actual use and products may dictate more frequent cleaning. Circumstances of use and equipment design must also dictate the frequency of cleaning the display areas. Weekly washing down of the storage compartment is also recommended, especially for equipment subject to drippage of milk or other liquids, or the collection of vegetable, meat, crumbs, etc. or other debris or litter. Daily cleaning of the external areas surrounding the storage or display compartments with detergent and water will keep the equipment presentable and prevent grime buildup.
  2. Load levels as defined by the manufacturer must be observed.
  3. The best preservation is achieved by following these rules:
    - a) Buy quality products.
    - b) Receive perishables from transit equipment at the ideal temperature for the particular product.
    - c) Expedite perishables to the store's storage equipment to avoid unnecessary warm-up and prolonged temperature recovery. Food store refrigerators are not food chillers nor can they reclaim quality lost through previous mishandling.
    - d) Care must be taken when cross merchandising products to ensure that potentially hazardous vegetable products are not placed in non refrigerated areas.
    - e) Display and storage equipment doors should be kept closed during periods of inactivity.
    - f) Minimize the transfer time of perishables from storage to display.
    - g) Keep meat under refrigeration in meat cutting and processing area except for the few

## Appendices (Cont'd)

moments it is being handled in processing. When a cut or tray of meat is not to be worked on immediately, the procedure should call for returning it to refrigeration.

- h) Keep tools clean and sanitized. Since mechanical equipment is used for fresh meat processing, all such equipment should be cleaned at least daily and each time a different kind of meat product comes in contact with the tool or equipment.
- i) Make sure that all refrigeration equipment is installed and adjusted in strict accordance with the manufacturer's recommendations.
- j) See that all storage and refrigeration equipment is kept in proper working order by routine maintenance.

### Hot

- 1.0 Hussmann should provide instructions and recommendations for proper periodic cleaning. The user will be responsible for such cleaning, including the cleaning of equipment within the compartment and the hot area(s). Cleaning practices, particularly with respect to proper refrigerator unloading and warm-up, must be in accordance with applicable recommendations.
1. Allow the case to preheat for one hour prior to loading.
  2. Hot foods should enter the case directly after cooking or no lower than 150° - 160°F. The Hot Cases are not designed to heat up or cook food.
  3. Self Service - be sure to display product in single layer in direct contact with heating surface and/or wire rack.
  4. All griddle type units are designed to maintain temperatures above the FDA guideline of 140°F. This is product temperature, not air or griddle temperature. Due to the open design of these units, they must be loaded with product for proper operation. When units are empty, they experience rapid rise of heated air from air outside the case. This action gives empty units a false, lower than desired, temperature reading. Loading the case traps the air at the griddle, raising temperatures to the 165°F to 185°F range, keeping product well above the FDA guidelines. Remember, these units must be loaded with product to maintain safe product temperature.

5. Check the food pulp temperature frequently with a thermometer to make sure it is at the proper holding temperature. Hot foods should be at 140°F. The thermometer must be inserted into the food itself for the proper temperature.
6. Do not display more food than will be sold within a 4 hour period.
7. When restocking, bring older food to the front, and stock fresher food on top.
8. Clean spills as soon as they happen.
9. Fingerprints and food splatter will drastically shorten bulb life. Clean splatter oil the bulbs immediately with a soft cloth. When handling bulbs, wear cotton gloves or use a cotton rag/towel.
10. When "freshening" foods such as macaroni and cheese with added water, heat the water in a clean container until it is 10° to 20°F above the desired holding temperature of the food. This will keep the food at a safe serving temperature. Depending on the amount of water, the temperature can drop 10° to 20°F in as little as five minutes.
11. When transferring hot foods in the heated merchandiser to clean pans, preheat the clean pan. Transferring hot foods to room temperature pans can cause the temperature of the food to drop 20°F or more thus causing food to be at an unsafe serving temperature.
12. Clean spills as they happen simply by wiping with a cloth. Be sure to use a dry cloth on very hot surfaces to prevent steam burns.
13. Turn the equipment off and allow to cool before cleaning.
14. To remove "baked-on" splatter from Stainless Steel, the following may be used
 

Grade F Italian Pumice	Scour or rub
with a	damp
cloth	
Liquid NuSteel	Scour with a small
	amount of a dry cloth
	Paste NuSteel
Household Cleaners	Rub with a damp cloth
Coopers Stainless Steel Cleaner	
Allen Stainless Steel Polish	

For further technical information, please log on to <http://www.hussmann.com/products/R3HTO.htm> or <http://www.hussmann.com/products/R3H.htm>



---

This warning does not mean that Hussmann products will cause cancer or reproductive harm, or is in violation of any product-safety standards or requirements. As clarified by the California State government, Proposition 65 can be considered more of a ‘right to know’ law than a pure product safety law. When used as designed, Hussmann believes that our products are not harmful. We provide the Proposition 65 warning to stay in compliance with California State law. It is your responsibility to provide accurate Proposition 65 warning labels to your customers when necessary. For more information on Proposition 65, please visit the California State government website.

---

### Service Record

Last service date:      By:

_____	_____
_____	_____
_____	_____
_____	_____
_____	_____
_____	_____
_____	_____
_____	_____

---

## HUSSMANN®/Chino

Additional copies of this publication may be obtained by contacting:  
Hussmann® Chino  
13770 Ramona Avenue • Chino, California 91710  
(909) 628-8942 FAX  
(909) 590-4910  
(800) 395-9229

The *MODEL NAME* and *SERIAL NUMBER* is required in order to provide you with the correct parts and information for your particular unit.

They can be found on a small metal plate on the unit. Please note them below for future reference.

**MODEL:**

**SERIAL NUMBER:**