

**HUSSMANN** CHINO  
**DSF, DSFI, DSFM, DSFN,-EP**  
**OPEN FISH SERVICE CASE**

Installation  
& Operation  
Manual  
REV. 0824

**DSF, DSFI, DSFM, DSFN,-EP**  
**OPEN FISH SERVICE CASE**

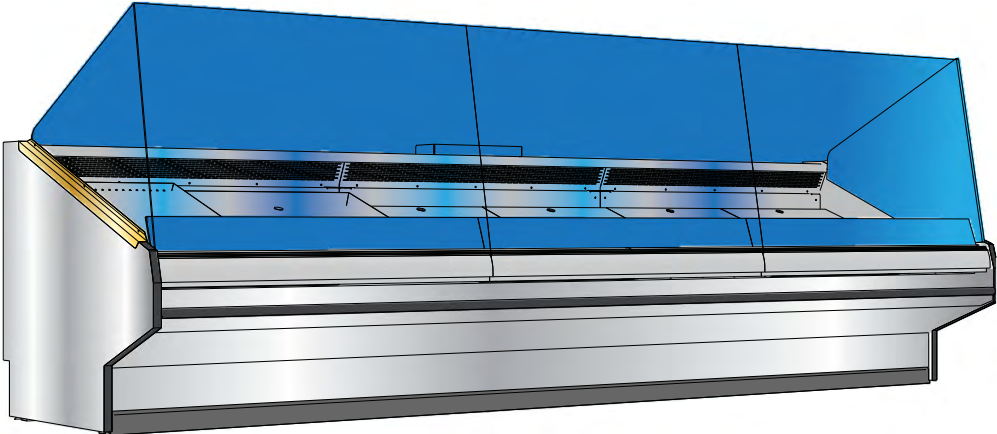

## Table of Contents

<b>General Information.....</b>	<b>4</b>
<b>Cut and Plan Views .....</b>	<b>5</b>
<b>Spec Sheet .....</b>	<b>8</b>
<b>Installation.....</b>	<b>15</b>
<b>Body Panel Removal .....</b>	<b>16</b>
<b>Glass Adjustment .....</b>	<b>17</b>
<b>Swing Arm Adjustment .....</b>	<b>19</b>
<b>Top Canopy Adjustment (HEB).....</b>	<b>20</b>
<b>Lifting Instructions .....</b>	<b>21</b>
<b>Plumbing .....</b>	<b>23</b>
<b>Humidification .....</b>	<b>24</b>
<b>Manifold Flush System .....</b>	<b>25</b>
<b>Refrigeration .....</b>	<b>26</b>
<b>Electrical .....</b>	<b>27</b>
<b>Electrical Wiring Diagram Index .....</b>	<b>28</b>
<b>Wiring Diagrams .....</b>	<b>29</b>
<b>Maintenance .....</b>	<b>48</b>
<b>Service Tips .....</b>	<b>49</b>
<b>User Information .....</b>	<b>50</b>



1. Do Not Push, Pull, Adjust, or Manipulate the DSF case by any glass component.
  - Doing so will result in severe damage to such components
  - Glass breakage may result in serious injury
2. Never stand on the top, deck, or any merchandising feature for any reason.
  - Misusing these surfaces as steps will result in damage to the case
  - Misusing these surfaces as steps may result in serious injury to the user
  - These surfaces are intended for the storage and merchandising of food products only
  - Use a ladder or designed structure to work above the case (Do not lean on case)

## General Information

### Case Description:

This Booklet specifically covers the following models:

- DSF,DSFI,DSFM,DSFN,-EP

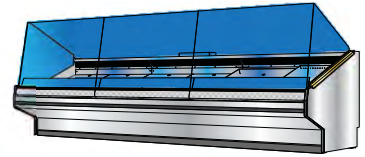

**Description:** The *DSF, DSFI, DSFM, DSFN, DSFM-VG, EP Straight-glass refrigerated service Open Fish merchandiser* is designed for Fresh Seafood Applications. They are available as either remote type models, which require separate condensing unit connections.

**Shipping Damage:** All equipment should be thoroughly examined for shipping damage before and during unloading. This equipment has been carefully inspected at our factory and the carrier has assumed responsibility for safe arrival. If damaged, either apparent or concealed, claim must be made to the carrier.

**Apparent Loss or Damage:** If there is an obvious loss or damage, it must be noted on the freight bill or express receipt and signed by the carrier's agent; otherwise, carrier may refuse claim. The carrier will supply necessary claim forms.

**Concealed Loss or Damage:** When loss or damage is not apparent until after all equipment is uncrated, a claim for concealed damage is made. Make request in writing to carrier for inspection within 15 days, and retain all packaging. The carrier will supply inspection report and required claim forms.

**Location/Store Conditions:** The refrigerated merchandisers have been designed for use only in air conditioned stores where temperature and humidity are maintained either 75°F ambient and 55% RH or 80°F and 55% RH . DO NOT allow air conditioning, electric fans, ovens, open doors or windows (etc.) to create air currents around the merchandiser, as this will impair its correct operation.

**Shortages:** Check your shipment for any possible shortages of material. If a shortage should exist and is found to be the responsibility of Hussmann Chino, notify Hussmann Chino. If such a shortage involves the carrier, notify the carrier immediately, and request an inspection. Hussmann Chino will acknowledge shortages within ten days from receipt of equipment.

**Hussmann Chino Product Control:** The serial number and shipping date of all equipment has been recorded in Hussmann's files for warranty and replacement part purposes. All correspondence pertaining to warranty or parts ordering must include the serial number of each piece of equipment involved, in order to provide the customer with the correct parts.

Keep this booklet with the case at all times for future reference.

## HUSSMANN®/CHINO

A publication of HUSSMANN® Chino  
13770 Ramona Avenue • Chino, California 91710  
(909) 628-8942 FAX  
(909) 590-4910  
(800) 395-9229



This equipment is to be installed to comply with the applicable NEC, Federal, State, and Local Plumbing and Construction Code having jurisdiction.

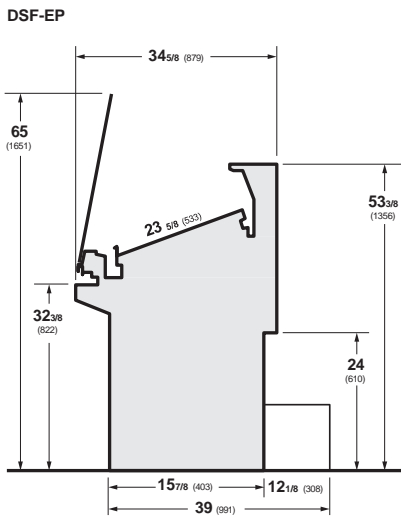
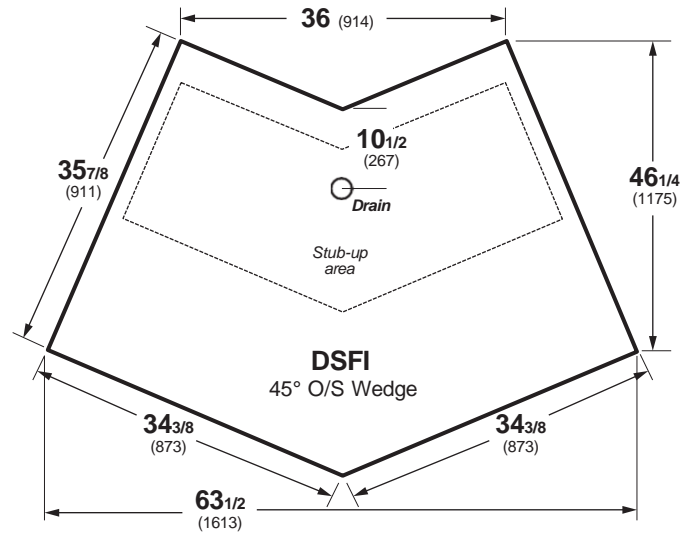
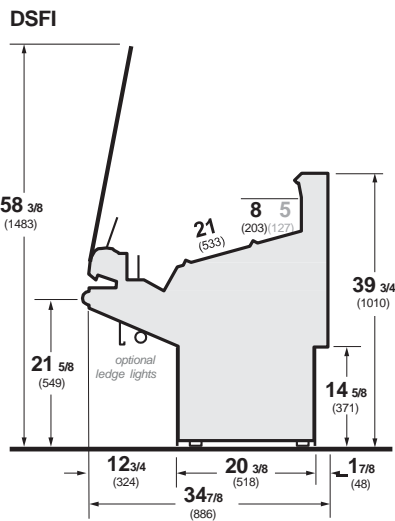
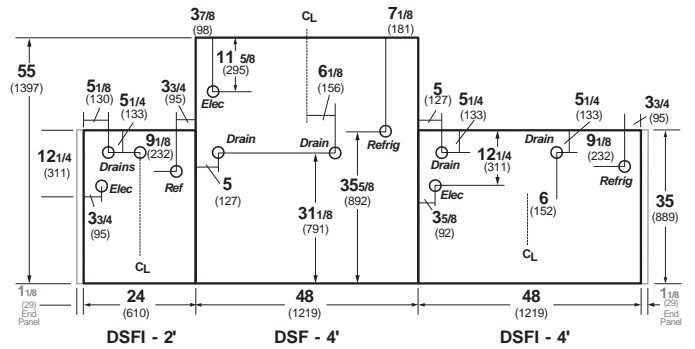
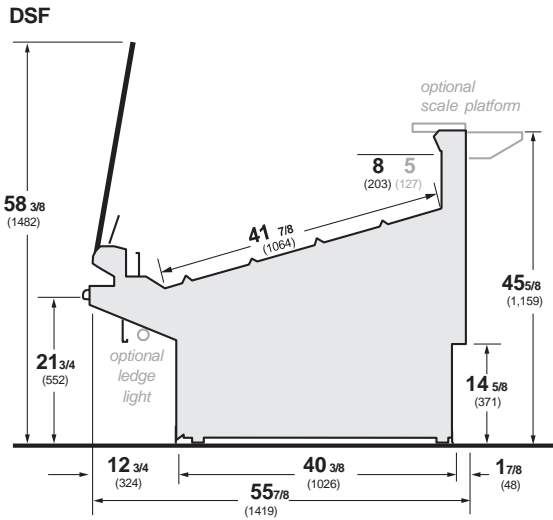

DSFM with Straight glass

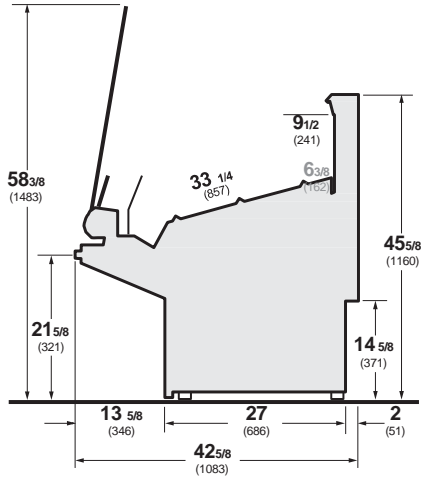

DSFM

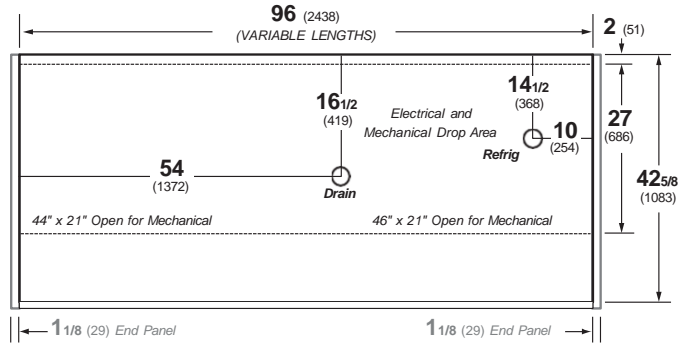

Notes:  
Contact your sales representative for information on possible availability of additional case lengths.

DSFM-EP

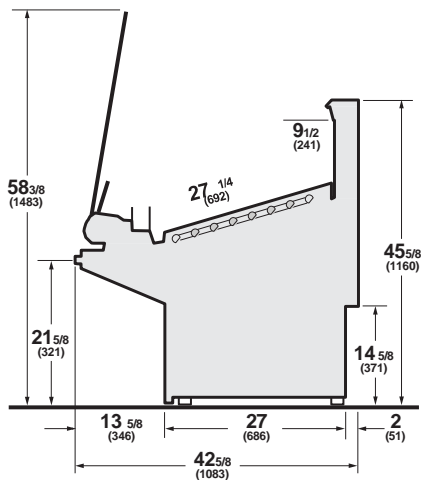

DSFM 45° O/S Wedge

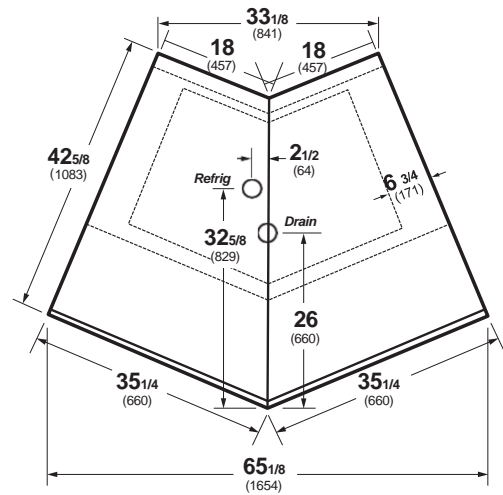

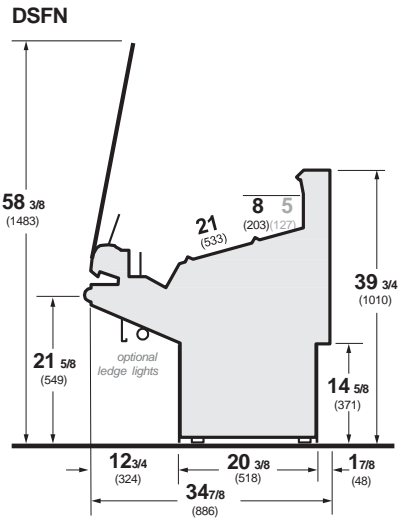

**DSFN - 4'**

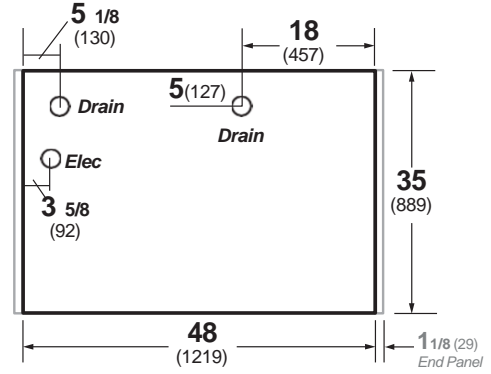

Notes:  
Contact your sales representative for information on possible availability of additional case lengths.

**DSFN-EP**

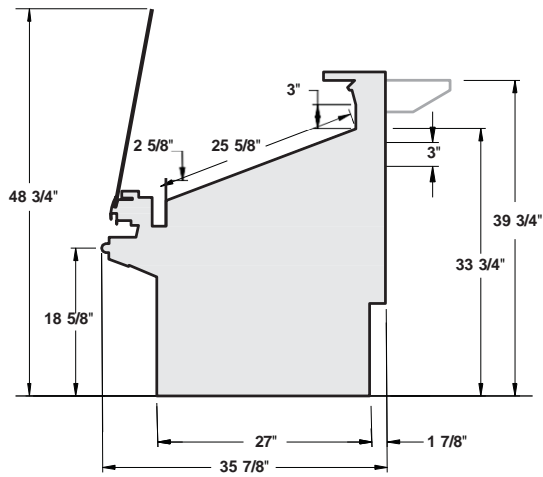

**DSFN-EP - 8'**

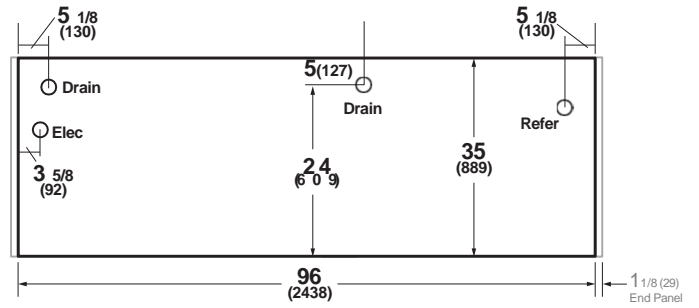

Notes:  
Contact your sales representative for information on possible availability of additional case lengths.



**SERVICE SEAFOOD**  
**HUSSMANN - DSF (CHINO)**

REVISION DATE 09/01/17

**DOE 2017 Energy Efficiency Compliant**  
 Hussmann refrigerated merchandisers configured for sale for use in the United States meet or surpass the requirements of the DOE 2017 energy efficiency standards.

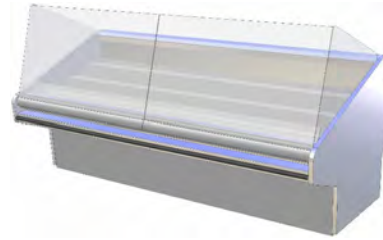

DSF

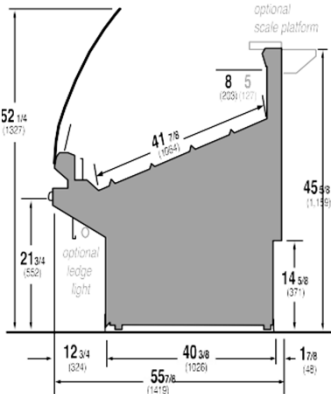

DSF

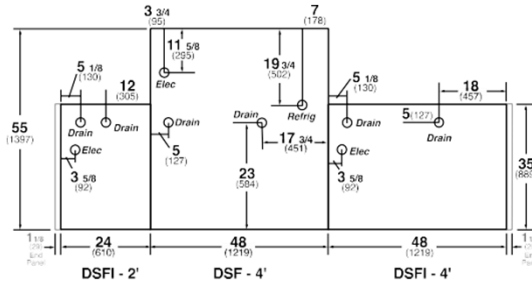
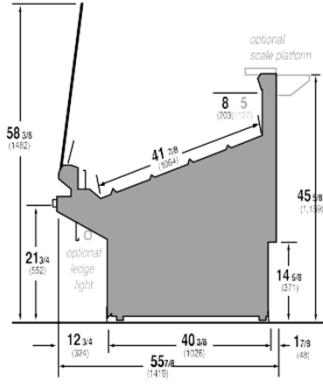

**REFRIGERATION DATA:**

CASE LENGTH	CASE USAGE	CAPACITY *** (BTU/HR/FT)		TEMPERATURE (°F)			VELOCITY (FT/MIN)
		RATING CONDITION		EVAPORATOR		DISCHARGE AIR ** (°F)	
		NSF 7	AHRI 1200	NSF 7	AHRI 1200	NSF 7	
2',3',4',5',6'	FRESH SEAFOOD	400	400	24	24	30-32	NSF 7

CASE LENGTH *	EST. REFG. CHR.G. (R404A) (LBS)	20°F GLYCOL 6° RISE	
		GPM	PSI
2'	0.3	0.3	0.1
3'	0.5	0.4	0.5
4'	0.7	0.6	1.1
5'	0.9	0.7	1.9
6'	1.1	0.8	0.4

\*\*FRONT DISCHARGE AIR MEASURED INSIDE AIR CURTAIN HONEYCOMB

\*\*\*REFRIGERATION NOTES:

- 1) BTU'S INCLUDE NO CANOPY LIGHTS AND NO SHELF LIGHTS
- 2) AHRI 1200 RATING POINT FOR ENERGY CONSUMPTION COMPARISON ONLY
- 3) USE DEW POINT FOR HIGH GLIDE REFRIGERANTS. CARE SHOULD BE TAKEN TO USE THE DEW POINT IN P/T TABLES FOR MEASURING AND ADJUSTING SUPERHEAT. ADJUST EVAPORATOR PRESSURE AS NEEDED TO MAINTAIN THE DISCHARGE AIR TEMPERATURE SHOWN.
- 4) THE PRINCIPAL COOLING EFFECT IN FISH CASES IS ACCOMPLISHED WITH A TRADITIONAL ICE BED. THE REFRIGERATION PRESERVES THE ICE AND MAINTAINS A COLD PROTECTIVE LAYER OVER THE PRODUCT.
- 5) RATING CONDITION IS NSF TYPE I, 75°F/55% RH

**REFRIGERATION DATA CONTINUED:**

ELEC. THERMOSTAT / AIR SENSOR SETTINGS			DEFROST TYPE	TIME (MIN)	DEFROST FREQUENCY (#/DAY)	TERM. TEMP (°F) COIL ONLY	DRIP TIME	DEFROST WATER (LBS/DAY/FT)
USAGE	CUT IN (°F)	CUT OUT (°F)						
FRESH SEAFOOD	33	30	OFF TIME	46	3	48	N/A	1.1

END PANEL WIDTH KEY		
# OF END PNLS	END PNL WIDTH (IN.)	TOTAL ADDED LENGTH (IN.)
1	1.125	1.125
2	1.125	2.25

**ELECTRICAL DATA:**

STANDARD FANS, HEATERS, LED LIGHTS (115 VOLT)

CASE LENGTH *	EVAPORATOR FANS					HUMIDITY FANS (OPTIONAL)			CANOPY LIGHTS LED OPTIONAL		OPTIONAL LED SHELF LIGHTS		MAX. LED LOAD (W/ ALL OPTIONS)		ANTI-SWEAT HEATERS		CONVENIENCE OUTLETS (OPTIONAL)			
	# OF EVAP FANS	BLADE DIA. (IN.)	BLADE PITCH (°)	AMPS	WATTS	# OF HUMIDITY FANS	AMPS	WATTS	AMPS	WATTS	AMPS	WATTS	AMPS	WATTS	AMPS	WATTS	# OUTLETS	VOLTS	AMPS	
2'	1	8	10	0.6	50	1	0.1	8	N/A	N/A	N/A	N/A	N/A	N/A	N/A	0.1	11	1	115	15
3'	1	8	10	0.6	50	1	0.1	8	N/A	N/A	N/A	N/A	N/A	N/A	N/A	0.1	17	1	115	15
4'	1	8	10	0.6	50	1	0.1	8	N/A	N/A	N/A	N/A	N/A	N/A	N/A	0.2	23	1	115	15
5'	2	8	10	0.6	50	1	0.1	8	N/A	N/A	N/A	N/A	N/A	N/A	N/A	0.2	29	1	115	15
6'	2	8	10	1.2	100	1	0.1	8	N/A	N/A	N/A	N/A	N/A	N/A	N/A	0.3	34	1	115	15

OPTIONAL HIGH OUTPUT LED LIGHTS (115 VOLT)

CASE LENGTH *	CANOPY LIGHTS H.O. LED		OPTIONAL SHELF		MAX. H.O. LED LOAD	
	AMPS	WATTS	AMPS	WATTS	AMPS	WATTS
2'	N/A	N/A	N/A	N/A	N/A	N/A
3'	N/A	N/A	N/A	N/A	N/A	N/A
4'	N/A	N/A	N/A	N/A	N/A	N/A
5'	N/A	N/A	N/A	N/A	N/A	N/A
6'	N/A	N/A	N/A	N/A	N/A	N/A



**SERVICE SEAFOOD - DEEP SERVICE FISH INLET**  
**HUSSMANN - DSFI REMOTE (CHINO)**

REVISION DATE 02/02/17



Hussmann refrigerated merchandisers configured for sale for use in the United States meet or surpass the requirements of the DOE 2017 energy efficiency standards.

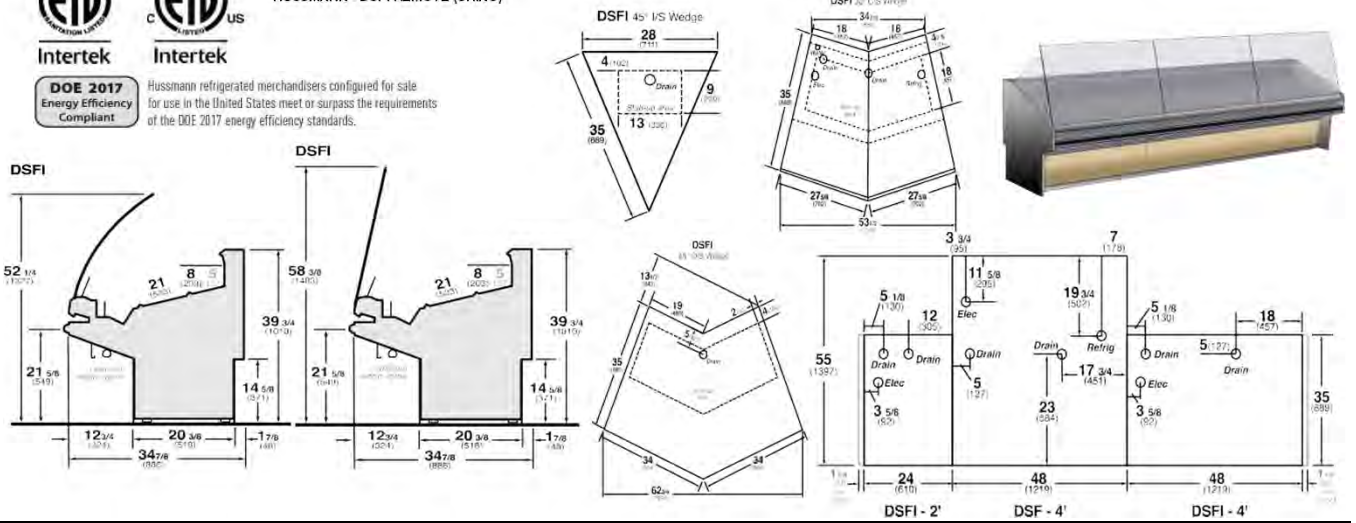

**REFRIGERATION DATA:**

CASE LENGTHS/ WEDGES	CASE USAGE	CAPACITY *** (BTU/HR/FT) (TOTAL FOR WEDGES)		TEMPERATURE (°F)			VELOCITY (FT/MIN)
		RATING CONDITION		EVAPORATOR		DISCHARGE AIR ** (°F)	
		NSF 7	AHRI 1200	NSF 7	AHRI 1200	NSF 7	
3', 4', 5'	FRESH SEAFOOD	250	250	26	26	32	500
45° IS	FRESH SEAFOOD	500	500	26	26	32	500
45° OS	FRESH SEAFOOD	1200	1200	26	26	32	500
30° OS	FRESH SEAFOOD	1000	1000	26	26	32	500

CASE LENGTHS	EST. REFRIG. CHRG. 404A (LBS)	GLYCOL (20°F INLET, 6° RISE)	
		GPM	PSI
3'	0.5	0.3	0.1
4'	0.7	0.4	0.3
5'	0.9	0.4	0.7
45° IS	0.2	0.2	0.3
45° OS	0.2	0.4	1.7
30° OS	0.2	0.3	1.1

\*\*FRONT DISCHARGE AIR MEASURED INSIDE AIR CURTAIN HONEYCOMB

\*\*\*REFRIGERATION NOTES:

- AHRI 1200 RATING POINT FOR ENERGY CONSUMPTION COMPARISON ONLY
- USE DEW POINT FOR HIGH GLIDE REFRIGERANTS. CARE SHOULD BE TAKEN TO USE THE DEW POINT IN P/T TABLES FOR MEASURING AND ADJUSTING SUPERHEAT. ADJUST EVAPORATOR PRESSURE AS NEEDED TO MAINTAIN THE DISCHARGE AIR TEMPERATURE SHOWN.
- THE PRINCIPAL COOLING EFFECT IN FISH CASES IS ACCOMPLISHED WITH A TRADITIONAL ICE BED. THE REFRIGERATION PRESERVES THE ICE AND MAINTAINS A COLD PROTECTIVE LAYER OVER THE PRODUCT.
- RATING CONDITION IS NSF TYPE I, 75°F/55% RH

**REFRIGERATION DATA CONTINUED:**

ELEC. THERMOSTAT / AIR SENSOR SETTINGS		DEFROST TYPE	TIME (MIN)	DEFROST FREQUENCY (#/DAY)	TERM. TEMP (°F) COIL ONLY	DRIP TIME	DEFROST WATER (LBS/DAY/FT)	
USAGE	CUT IN (°F)							CUT OUT (°F)
FRESH SEAFOOD	33	30	OFF TIME	46	3	48	N/A	1.1

END PANEL WIDTH KEY		
# OF END PNLS	END PNL WIDTH (IN.)	TOTAL ADDED LENGTH (IN.)
1	1.125	1.125
2	1.125	2.25

**ELECTRICAL DATA:**

**STANDARD FANS, HEATERS, LED LIGHTS (115 VOLT)**

CASE LENGTH	EVAPORATOR FANS					CANOPY LIGHTS LED		OPTIONAL LED SHELF LIGHTS		MAX. LED LOAD (W/ ALL OPTIONS)		ANTI-SWEAT HEATERS		CONVENIENCE OUTLETS (OPTIONAL)			HUMIDITY SYSTEM FANS (OPTIONAL) (3" AXIAL FAN)		
	# OF EVAP FANS	BLADE DIA. (IN.)	BLADE PITCH (°)	AMPS	WATTS	AMPS	WATTS	AMPS	WATTS	AMPS	WATTS	AMPS	WATTS	# OF OUTLETS	VOLTS	AMPS	# OF FANS	AMPS	WATTS
3'	1	6.7	10	0.6	50	N/A	N/A	N/A	N/A	N/A	N/A	0.1	17	1	115	15	1	0.1	8
4'	1	6.7	10	0.6	50	N/A	N/A	N/A	N/A	N/A	N/A	0.2	23	1	115	15	1	0.1	8
5'	2	6.7	10	1.2	100	N/A	N/A	N/A	N/A	N/A	N/A	0.2	29	1	115	15	1	0.1	8
45° IS	1	6.7	10	0.6	50	N/A	N/A	N/A	N/A	N/A	N/A	0.1	11	N/A	N/A	N/A	1	0.1	8
45° OS	1	6.7	10	0.6	50	N/A	N/A	N/A	N/A	N/A	N/A	0.2	29	N/A	N/A	N/A	1	0.1	8
30° OS	1	6.7	10	0.6	50	N/A	N/A	N/A	N/A	N/A	N/A	0.2	23	N/A	N/A	N/A	1	0.1	8

**OPTIONAL HIGH OUTPUT LED LIGHTS (115 VOLT)**

CASE LENGTH	CANOPY LIGHTS H.O. LED		OPTIONAL SHELF		MAX. H.O. LED LOAD	
	AMPS	WATTS	AMPS	WATTS	AMPS	WATTS
3'	N/A	N/A	N/A	N/A	N/A	N/A
4'	N/A	N/A	N/A	N/A	N/A	N/A
5'	N/A	N/A	N/A	N/A	N/A	N/A
45° IS	N/A	N/A	N/A	N/A	N/A	N/A
45° OS	N/A	N/A	N/A	N/A	N/A	N/A
30° OS	N/A	N/A	N/A	N/A	N/A	N/A



**SERVICE/SELF-SERVICE SEAFOOD DEEP SERVICE FISH MEAT**  
**HUSSMANN - DSFM REMOTE (CHINO)**

REVISION DATE 02/02/17

**DOE 2017 Energy Efficiency Compliant**  
 Hussmann refrigerated merchandisers configured for sale for use in the United States meet or surpass the requirements of the DOE 2017 energy efficiency standards.

DSFM with Curved glass

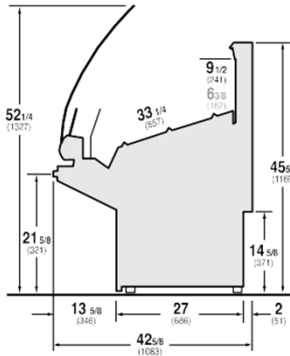

DSFM with Straight glass

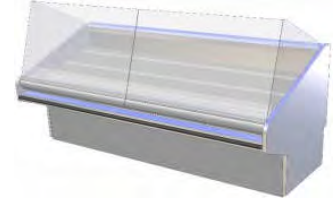
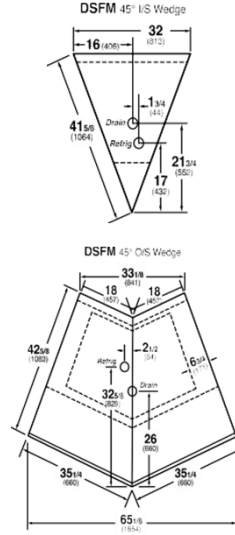
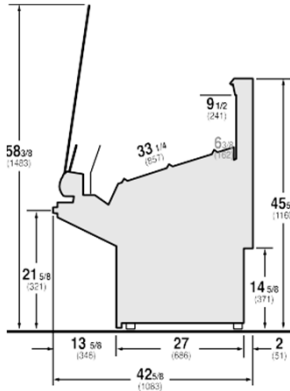

DSFM

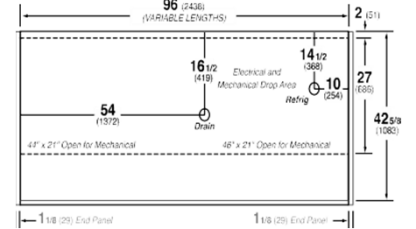

Notes:  
 Contact your sales representative for information on possible availability of additional case lengths.

**REFRIGERATION DATA:**

CASE LENGTHS/ WEDGES	CASE USAGE	CAPACITY *** (BTU/HR/FT) (TOTAL FOR WEDGES)		TEMPERATURE (°F)			VELOCITY (FT/MIN)
		RATING CONDITION		EVAPORATOR		DISCHARGE AIR ** (°F)	
		NSF 7	AHRI 1200	NSF 7	AHRI 1200	NSF 7	
4, 6', 8', 10', 12'	FRESH SEAFOOD	300	300	24	24	31-33	350-500
45° IS	FRESH SEAFOOD	1800	1800	24	24	31-33	350-500
45° OS	FRESH SEAFOOD	1800	1800	24	24	31-33	350-500

CASE LENGTHS	EST. REFG. CHR.G. 404A (LBS)	GLYCOL (20°F INLET, 6° RISE)	
		GPM	PSI
4'	0.9	0.4	0.7
6'	1.3	0.6	0.3
8'	1.8	0.8	0.5
10'	2.3	1.0	0.9
12'	2.8	1.2	1.2
45° IS	0.8	0.6	1.0
45° OS	0.8	0.6	0.4

\*\*\*FRONT DISCHARGE AIR MEASURED INSIDE AIR CURTAIN HONEYCOMB

\*\*\*REFRIGERATION NOTES:

- AHRI 1200 RATING POINT FOR ENERGY CONSUMPTION COMPARISON ONLY
- USE DEW POINT FOR HIGH GLIDE REFRIGERANTS. CARE SHOULD BE TAKEN TO USE THE DEW POINT IN P/T TABLES FOR MEASURING AND ADJUSTING SUPERHEAT. ADJUST EVAPORATOR PRESSURE AS NEEDED TO MAINTAIN THE DISCHARGE AIR TEMPERATURE SHOWN.
- THE PRINCIPAL COOLING EFFECT IN FISH CASES IS ACCOMPLISHED WITH A TRADITIONAL ICE BED. THE REFRIGERATION PRESERVES THE ICE AND MAINTAINS A COLD PROTECTIVE LAYER OVER THE PRODUCT.
- RATING CONDITION IS NSF TYPE I, 75°F/55% RH

REFRIGERATION DATA CONTINUED:

ELEC. THERMOSTAT / AIR SENSOR SETTINGS			DEFROST TYPE	TIME (MIN)	DEFROST FREQUENCY (#/DAY)	TERM. TEMP (°F) COIL ONLY	DRIP TIME	DEFROST WATER (LBS/DAY/FT)
USAGE	CUT IN (°F)	CUT OUT (°F)						
FRESH SEAFOOD	33	30	OFF TIME	46	3	48	N/A	N/A

END PANEL WIDTH KEY		
# OF END PNLS	END PNL WIDTH (IN.)	TOTAL ADDED LENGTH (IN.)
1	1.125	1.125
2	1.125	2.25

**ELECTRICAL DATA:**

STANDARD FANS, HEATERS, LED LIGHTS (115 VOLT)

CASE LENGTH	EVAPORATOR FANS				OPTIONAL BOOM LIGHTS LED		OPTIONAL LED SHELF LIGHTS		MAX. LED LOAD (W/ ALL OPTIONS)		ANTI-SWEAT HEATERS		CONVENIENCE OUTLETS (OPTIONAL)			HUMIDITY SYSTEM FANS (OPTIONAL) (3" AXIAL FAN)			
	# OF EVAP FANS	BLADE DIA. (IN.)	BLADE PITCH (°)	AMPS	WATTS	AMPS	WATTS	AMPS	WATTS	AMPS	WATTS	AMPS	WATTS	# OUTLETS	VOLTS	AMPS	# OF FANS	AMPS	WATTS
4'	1	8	10	0.6	50	0.2	27	N/A	N/A	0.2	27	0.2	23	1	115	15	1	0.1	8
6'	2	8	10	1.2	100	0.3	39	N/A	N/A	0.3	39	0.3	34	1	115	15	1	0.1	8
8'	2	8	10	1.2	100	0.5	54	N/A	N/A	0.5	54	0.4	46	1	115	15	1	0.1	8
10'	3	8	10	1.9	150	0.6	68	N/A	N/A	0.6	68	0.5	57	1	115	15	1	0.1	8
12'	3	8	10	1.9	150	0.7	81	N/A	N/A	0.7	81	0.6	68	1	115	15	2	0.2	16
45° OS	1	8	10	0.6	50	N/A	N/A	N/A	N/A	N/A	N/A	0.1	11	1	115	15	1	0.1	8
45° IS	1	8	10	0.6	50	N/A	N/A	N/A	N/A	N/A	N/A	0.2	29	1	115	15	1	0.1	8

OPTIONAL HIGH OUTPUT LED LIGHTS (115 VOLT)

CASE LENGTH	BOOM LIGHTS H.O. LED (OPTIONAL)		OPTIONAL SHELF		MAX. H.O. LED LOAD	
	AMPS	WATTS	AMPS	WATTS	AMPS	WATTS
4'	0.3	32	N/A	N/A	0.3	32
6'	0.4	47	N/A	N/A	0.4	47
8'	0.6	64	N/A	N/A	0.6	64
10'	0.7	81	N/A	N/A	0.7	81
12'	0.8	96	N/A	N/A	0.8	96
45° OS	N/A	N/A	N/A	N/A	N/A	N/A
45° IS	N/A	N/A	N/A	N/A	N/A	N/A



**SERVICE SEAFOOD**  
**HUSSMANN - DSFM-EP-R (CHINO)**

REVISION DATE 10/13/2020

**DOE 2017 Energy Efficiency Compliant**  
 Hussmann refrigerated merchandisers configured for sale for use in the United States meet or surpass the requirements of the DOE 2017 energy efficiency standards.

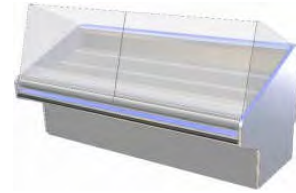

DSFM with Curved glass

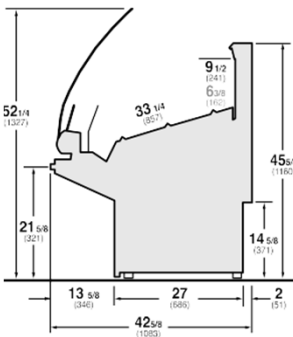

DSFM with Straight glass

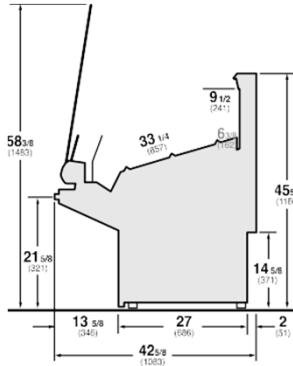

DSFM

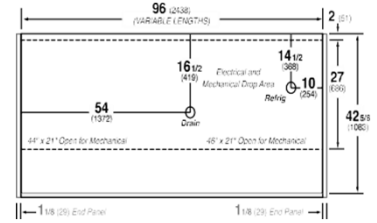

Notes:  
 Contact your sales representative for information on possible availability of additional case lengths.

**REFRIGERATION DATA:**

CASE LENGTHS	CASE USAGE	CAPACITY *** (BTU/HR/FT) (TOTAL FOR WEDGES)		TEMPERATURE (°F)			VELOCITY (FT/MIN)
		RATING CONDITION		EVAPORATOR		DISCHARGE AIR ** (°F)	
		NSF 7	AHRI 1200	NSF 7	AHRI 1200	NSF 7	
4', 5', 6', 8', 10', 12'	FRESH SEAFOOD	400	400	20	20	32	50-100
45° OS	FRESH SEAFOOD	1700	1700	20	20	32	50-100

CASE LENGTHS	EST. REFG. CHRG. 404A (LBS)	GLYCOL (18°F INLET, 4° RISE)	
		GPM	PSI
4'	1.2	0.6	0.4
5'	1.3	0.7	0.8
6'	1.4	0.8	1.2
8'	1.5	1.1	0.7
10'	1.6	1.3	1.2
12'	1.8	1.5	1.8
45° OS	2.1	2.7	2.2

\*\*FRONT DISCHARGE AIR MEASURED INSIDE AIR CURTAIN HONEYCOMB

\*\*\*REFRIGERATION NOTES:

- AHRI 1200 RATING POINT FOR ENERGY CONSUMPTION COMPARISON ONLY
- USE DEW POINT FOR HIGH GLIDE REFRIGERANTS. CARE SHOULD BE TAKEN TO USE THE DEW POINT IN P/T TABLES FOR MEASURING AND ADJUSTING SUPERHEAT. ADJUST EVAPORATOR PRESSURE AS NEEDED TO MAINTAIN THE DISCHARGE AIR TEMPERATURE SHOWN.
- RATING CONDITION IS NSF TYPE I, 75°F/55% RH

**REFRIGERATION DATA CONTINUED:**

CASE LENGTHS	ELEC. THERMOSTAT / AIR SENSOR SETTINGS		DEFROST TYPE	TIME (MIN)	DEFROST FREQUENCY (#/DAY)	TERM. TEMP (°F) COIL ONLY	DRIP TIME	DEFROST WATER (LBS/DAY/FT)
	USAGE	CUT IN (°F)						
4', 5', 6', 8', 10', 12'	BLOWER COIL	31	29	OFF TIME	46	3	48	N/A
	DECK COIL	31	30					
45° OS	BLOWER COIL	27	25	OFF TIME	46	3	48	N/A
	DECK COIL	26	25					

END PANEL WIDTH KEY		
# OF END PNLS	END PNL WIDTH (IN.)	TOTAL ADDED LENGTH (IN.)
1	1.125	1.125
2	1.125	2.25

**ELECTRICAL DATA:**

STANDARD FANS, HEATERS, LED LIGHTS (115 VOLT)

CASE LENGTH	EVAPORATOR FANS					OPTIONAL LED SHELF LIGHTS		MAX. LED LOAD (W/ ALL OPTIONS)		ANTI-SWEAT HEATERS		CONVENIENCE OUTLETS (OPTIONAL)			HUMIDITY SYSTEM FANS (OPTIONAL) (3" AXIAL FAN)		
	# OF EVAP FANS	BLADE DIA. (IN.)	BLADE PITCH (°)	AMPS	WATTS	AMPS	WATTS	AMPS	WATTS	AMPS	WATTS	# OUTLETS	VOLTS	AMPS	# OF EVAP FANS	AMPS	WATTS
4'	1	6.7	20	0.6	50	N/A	N/A	N/A	N/A	0.2	23	1	115	15	1	0.1	8
5'	2	6.7	20	1.2	100	N/A	N/A	N/A	N/A	0.2	29	1	115	15	1	0.1	8
6'	2	6.7	20	1.2	100	N/A	N/A	N/A	N/A	0.3	34	1	115	15	1	0.1	8
8'	2	6.7	20	1.2	100	N/A	N/A	N/A	N/A	0.4	46	1	115	15	1	0.1	8
10'	4	6.7	20	2.5	200	N/A	N/A	N/A	N/A	0.5	57	1	115	15	1	0.1	8
12'	3	6.7	20	1.9	150	N/A	N/A	N/A	N/A	0.6	68	1	115	15	1	0.1	8
45° OS	2	6.7	10	1.2	100	N/A	N/A	N/A	N/A	0.3	34	1	115	15	N/A	N/A	N/A

OPTIONAL HIGH OUTPUT LED LIGHTS (115 VOLT)

CASE LENGTH	OPTIONAL SHELF		MAX. H.O. LED LOAD	
	AMPS	WATTS	AMPS	WATTS
4'	N/A	N/A	N/A	N/A
5'	N/A	N/A	N/A	N/A
6'	N/A	N/A	N/A	N/A
8'	N/A	N/A	N/A	N/A
10'	N/A	N/A	N/A	N/A
12'	N/A	N/A	N/A	N/A
45° OS	N/A	N/A	N/A	N/A



**SERVICE SEAFOOD**  
**HUSSMANN - DSFM-VG REMOTE (CHINO)**

REVISION DATE 09/01/17

**DOE 2017 Energy Efficiency Compliant** Hussmann refrigerated merchandisers configured for sale for use in the United States meet or surpass the requirements of the DOE 2017 energy efficiency standards.

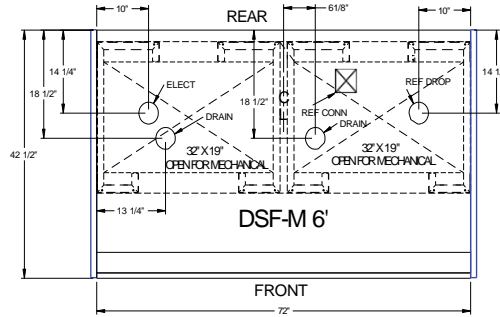
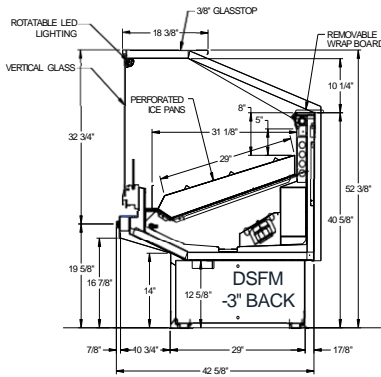
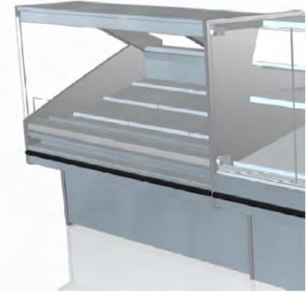

**REFRIGERATION DATA:**

CASE LENGTHS	CASE USAGE	CAPACITY *** (BTU/HR/FT)		TEMPERATURE (°F)			VELOCITY (FT/MIN)
		RATING CONDITION		EVAPORATOR		DISCHARGE AIR * (°F)	
		NSF 7	AHRI 1200	NSF 7	AHRI 1200	NSF 7	
6', 8', 10', 12'	FRESH SEAFOOD	450	450	24	24	32	130-160

CASE LENGTHS	EST. REFG. CHR.G. 404A (LBS)	GLYCOL (20°F INLET, 6° RISE)	
		GPM	PSI
6'	1.3	0.9	0.5
8'	1.8	1.2	1.0
10'	2.3	1.5	1.5
12'	2.8	1.8	2.1

\*FRONT DISCHARGE AIR MEASURED INSIDE AIR CURTAIN HONEYCOMB  
 \*\*DEFROST WATER DOES NOT INCLUDE ICE MELT RATE FROM STANDARD CASE OPERATION  
 \*\*\*REFRIGERATION NOTES:

- 1) BTU'S INCLUDE 1 ROW OF CANOPY LIGHTS
- 2) AHRI 1200 RATING POINT FOR ENERGY CONSUMPTION COMPARISON ONLY
- 3) USE DEW POINT FOR HIGH GLIDE REFRIGERANTS. CARE SHOULD BE TAKEN TO USE THE DEW POINT IN P/T TABLES FOR MEASURING AND ADJUSTING SUPERHEAT. ADJUST EVAPORATOR PRESSURE AS NEEDED TO MAINTAIN THE DISCHARGE AIR TEMPERATURE SHOWN.
- 4) THE PRINCIPAL COOLING EFFECT IN FISH CASES IS ACCOMPLISHED WITH A TRADITIONAL ICE BED. THE REFRIGERATION PRESERVES THE ICE AND MAINTAINS A COLD PROTECTIVE LAYER OVER THE PRODUCT.
- 5) RATING CONDITION IS NSF TYPE I, 75°F/55% RH

**REFRIGERATION DATA CONTINUED:**

ELEC. THERMOSTAT / AIR SENSOR SETTINGS			DEFROST TYPE	TIME (MIN)	DEFROST FREQUENCY (#/DAY)	TERM. TEMP (°F) COIL ONLY	DRIP TIME	DEFROST WATER** (LBS/DAY/FT)
USAGE	CUT IN (°F)	CUT OUT (°F)						
FRESH SEAFOOD	33	30	OFF TIME	46	3	38	N/A	1.6

END PANEL WIDTH KEY		
# OF END PNLS	END PNL WIDTH (IN.)	TOTAL ADDED LENGTH (IN.)
1	1.5	1.5
2	1.5	3.0

**ELECTRICAL DATA:**

**STANDARD FANS, HEATERS, LED LIGHTS (115 VOLT)**

CASE LENGTH	EVAPORATOR FANS					HUMIDITY FANS (OPTIONAL)			CANOPY LIGHTS LED		OPTIONAL LED SHELF LIGHTS		MAX. LED LOAD (W/ ALL OPTIONS)		ANTI-SWEAT HEATERS		CONVENIENCE OUTLETS (OPTIONAL)		
	# OF EVAP FANS	BLADE DIA. (IN.)	BLADE PITCH (°)	AMPS	WATTS	# OF HUMIDITY FANS	AMPS	WATTS	AMPS	WATTS	AMPS	WATTS	AMPS	WATTS	AMPS	WATTS	# OUTLETS	VOLTS	AMPS
6'	2	8	10	1.2	100	1	0.1	8	0.3	39	N/A	N/A	0.3	39	0.3	34	1	115	15
8'	2	8	10	1.2	100	1	0.1	8	0.5	54	N/A	N/A	0.5	54	0.4	46	1	115	15
10'	3	8	10	1.9	150	1	0.1	8	0.6	68	N/A	N/A	0.6	68	0.5	57	1	115	15
12'	3	8	10	1.9	150	1	0.1	8	0.7	81	N/A	N/A	0.7	81	0.6	68	1	115	15

**OPTIONAL HIGH OUTPUT LED LIGHTS (115 VOLT)**

CASE LENGTH	CANOPY LIGHTS H.O. LED		OPTIONAL SHELF		MAX. H.O. LED LOAD	
	AMPS	WATTS	AMPS	WATTS	AMPS	WATTS
6'	0.4	47	N/A	N/A	0.4	47
8'	0.6	64	N/A	N/A	0.6	64
10'	N/A	N/A	N/A	N/A	N/A	N/A
12'	0.8	96	N/A	N/A	0.8	96



**SERVICE SEAFOOD**  
**HUSSMANN - DSNF REMOTE (CHINO)**

REVISION DATE 02/02/17

**DOE 2017 Energy Efficiency Compliant**  
 Hussmann refrigerated merchandisers configured for sale for use in the United States meet or surpass the requirements of the DOE 2017 energy efficiency standards.

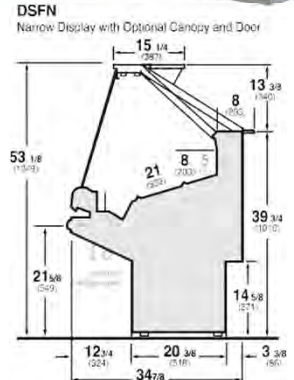
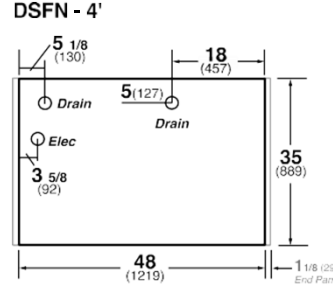
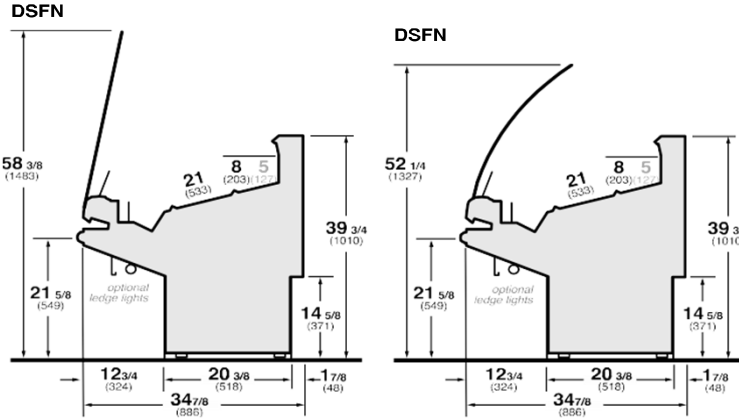
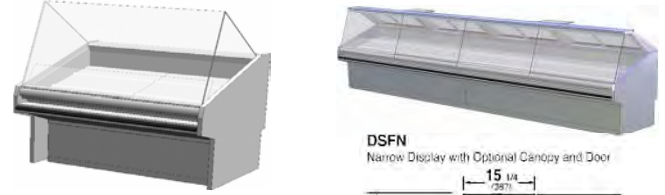

Notes:  
 Contact your sales representative for information on possible availability of additional case lengths.

**REFRIGERATION DATA:**

CASE LENGTHS	CASE USAGE	CAPACITY *** (BTU/HR/FT)		TEMPERATURE (°F)			VELOCITY (FT/MIN)
		RATING CONDITION		EVAPORATOR		DISCHARGE AIR ** (°F)	
		NSF 7	AHRI 1200	NSF 7	AHRI 1200	NSF 7	
3,4,5,6,8,10,12	FRESH SEAFOOD	250	250	24	24	32	500

CASE LENGHT HS	EST. REFG. CHRGS. 404A (LBS)	GLYCOL (20°F INLET, 6° RISE)	
		GPM	PSI
3'	0.5	0.3	0.1
4'	0.7	0.3	0.3
5'	0.9	0.4	0.6
6'	1.1	0.5	1.0
8'	1.5	0.7	0.5
10'	1.9	0.8	0.9
12'	2.4	1.0	1.3

\*\*FRONT DISCHARGE AIR MEASURED INSIDE AIR CURTAIN HONEYCOMB

\*\*\*REFRIGERATION NOTES:

- AHRI 1200 RATING POINT FOR ENERGY CONSUMPTION COMPARISON ONLY
- USE DEW POINT FOR HIGH GLIDE REFRIGERANTS. CARE SHOULD BE TAKEN TO USE THE DEW POINT IN P/T TABL FOR MEASURING AND ADJUSTING SUPERHEAT. ADJUST EVAPORATOR PRESSURE AS NEEDED TO MAINTAIN THE DISCHARGE AIR TEMPERATURE SHOWN.
- THE PRINCIPAL COOLING EFFECT IN FISH CASES IS ACCOMPLISHED WITH A TRADITIONAL ICE BED. THE REFRIGERATION PRESERVES THE ICE AND MAINTAINS A COLD PROTECTIVE LAYER OVER THE PRODUCT.
- RATING CONDITION IS NSF TYPE I, 75°F/55% RH

**REFRIGERATION DATA CONTINUED:**

ELEC. THERMOSTAT / AIR SENSOR SETTINGS			DEFROST TYPE	TIME (MIN)	DEFROST FREQUENCY (#/DAY)	TERM. TEMP (°F) COIL ONLY	DRIP TIME	DEFROST WATER (LBS/DAY/FT)
USAGE	CUT IN (°F)	CUT OUT (°F)						
FRESH SEAFOOD	33	30	OFF TIME	46	3	48	N/A	1.1

END PANEL WIDTH KEY		
# OF END PNLS	END PNL WIDTH (IN.)	TOTAL ADDED LENGTH (IN.)
1	1.125	1.125
2	1.125	2.25

**ELECTRICAL DATA:**

**STANDARD FANS, HEATERS, LED LIGHTS (115 VOLT)**

CASE LENGTH	EVAPORATOR FANS					OPTIONAL BOOM LIGHTS LED		OPTIONAL LED SHELF LIGHTS		MAX. LED LOAD (W/ ALL OPTIONS)		ANTI-SWEAT HEATERS		CONVENIENCE OUTLETS (OPTIONAL)			HUMIDITY SYSTEM FANS (OPTIONAL) (3" AXIAL FAN)		
	# OF EVAP FANS	BLADE DIA. (IN.)	BLADE PITCH (°)	AMPS	WATTS	AMPS	WATTS	AMPS	WATTS	AMPS	WATTS	AMPS	WATTS	# OUTLETS	VOLTS	AMPS	# OF EVAP FANS	AMPS	WATTS
3'	1	6.7	10	0.6	50	0.5	58	N/A	N/A	0.5	58	0.1	17	1	115	15	1	0.1	8
4'	1	6.7	10	0.6	50	0.9	108	N/A	N/A	0.9	108	0.2	23	1	115	15	1	0.1	8
5'	1	6.7	10	0.6	50	1.5	170	N/A	N/A	1.5	170	0.2	29	1	115	15	1	0.1	8
6'	2	6.7	10	1.2	100	1.0	116	N/A	N/A	1.0	116	0.3	34	1	115	15	1	0.1	8
8'	2	6.7	10	1.2	100	1.9	215	N/A	N/A	1.9	215	0.4	46	1	115	15	1	0.1	8
10'	3	6.7	10	1.9	150	3.0	339	N/A	N/A	3.0	339	0.5	57	1	115	15	1	0.1	8
12'	3	6.7	10	1.9	150	2.8	323	N/A	N/A	2.8	323	0.6	68	1	115	15	2	0.2	16

**OPTIONAL HIGH OUTPUT LED LIGHTS (115 VOLT)**

CASE LENGTH	BOOM LIGHTS H.O. LED (OPTIONAL)		OPTIONAL SHELF		MAX. H.O. LED LOAD	
	AMPS	WATTS	AMPS	WATTS	AMPS	WATTS
3'	0.6	71	N/A	N/A	0.6	71
4'	1.1	128	N/A	N/A	1.1	128
5'	1.8	202	N/A	N/A	1.8	202
6'	1.2	142	N/A	N/A	1.2	142
8'	2.2	256	N/A	N/A	2.2	256
10'	3.5	405	N/A	N/A	3.5	405
12'	3.3	383	N/A	N/A	3.3	383



**SERVICE SEAFOOD**  
**HUSSMANN - DSN-EP-R (CHINO)**

REVISION DATE 06/21/18

**DOE 2017 Energy Efficiency Compliant**  
 Hussmann refrigerated merchandisers configured for sale for use in the United States meet or surpass the requirements of the DOE 2017 energy efficiency standards.

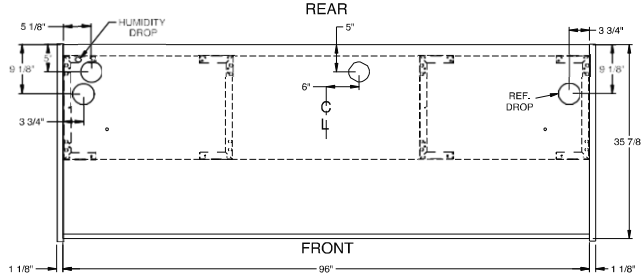
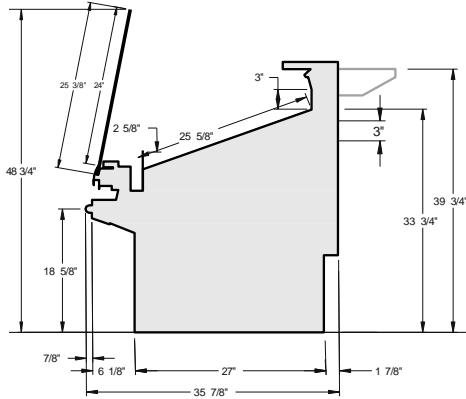
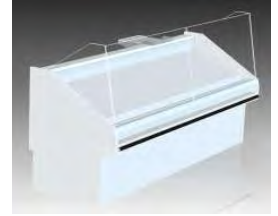

**REFRIGERATION DATA:**

CASE LENGTHS	CASE USAGE	CAPACITY *** (BTU/HR/FT) (TOTAL FOR WEDGES)		TEMPERATURE (°F)			VELOCITY (FT/MIN)
		RATING CONDITION		EVAPORATOR		DISCHARGE AIR ** (°F)	
		NSF 7	AHRI 1200	NSF 7	AHRI 1200	NSF 7	NSF 7
2', 3', 4', 5', 6', 8', 10', 12'	FRESH SEAFOOD	320	320	22	22	32	50-100
45"O	FRESH SEAFOOD	2000	2000	22	22	32	50-100

CASE LENGHT HS	EST. REFG. CHR.G. 404A (LBS)	GLYCOL (20°F INLET, 6" RISE)	
		GPM	PSI
2'	0.3	0.2	0.0
3'	0.5	0.3	0.0
4'	0.7	0.4	0.3
5'	0.9	0.6	0.5
6'	1.1	0.7	0.9
8'	1.5	0.8	0.5
10'	1.9	1.0	0.8
12'	2.4	1.2	1.2
45"O	0.4	3.2	2.8

\*\*FRONT DISCHARGE AIR MEASURED INSIDE AIR CURTAIN HONEYCOMB

\*\*\*REFRIGERATION NOTES:

- AHRI 1200 RATING POINT FOR ENERGY CONSUMPTION COMPARISON ONLY
- USE DEW POINT FOR HIGH GLIDE REFRIGERANTS. CARE SHOULD BE TAKEN TO USE THE DEW POINT IN P/T TABLES FOR MEASURING AND ADJUSTING SUPERHEAT. ADJUST EVAPORATOR PRESSURE AS NEEDED TO MAINTAIN THE DISCHARGE AIR TEMPERATURE SHOWN.
- RATING CONDITION IS NSF TYPE I, 75°F/55% RH

**REFRIGERATION DATA CONTINUED:**

ELEC. THERMOSTAT / AIR SENSOR SETTINGS			DEFROST TYPE	TIME (MIN)	DEFROST FREQUENCY (#/DAY)	TERM. TEMP (°F) COIL ONLY	DRIP TIME	DEFROST WATER (LBS/DAY/FT)
USAGE	CUT IN (°F)	CUT OUT (°F)						
BLOWER COIL	31	29	OFF TIME	46	3	48	N/A	TBD
SPIRAL COIL	31	30						

END PANEL WIDTH KEY		
# OF END PNLS	END PNL WIDTH (IN.)	TOTAL ADDED LENGTH (IN.)
1	1.125	1.125
2	1.125	2.25

**ELECTRICAL DATA:**

STANDARD FANS, HEATERS, LED LIGHTS (115 VOLT)

CASE LENGTH	EVAPORATOR FANS					OPTIONAL LED SHELF LIGHTS		MAX. LED LOAD (W/ ALL OPTIONS)		ANTI-SWEAT HEATERS		CONVENIENCE OUTLETS (OPTIONAL)			HUMIDITY SYSTEM FANS (OPTIONAL) (3" AXIAL FAN)		
	# OF EVAP FANS	BLADE DIA. (IN.)	BLADE PITCH (°)	AMPS	WATTS	AMPS	WATTS	AMPS	WATTS	AMPS	WATTS	# OUTLETS	VOLTS	AMPS	# OF EVAP FANS	AMPS	WATTS
2'	1	6.7	15	0.6	50	N/A	N/A	N/A	N/A	N/A	N/A	1	115	15	1	0.1	8
3'	1	6.7	15	0.6	50	N/A	N/A	N/A	N/A	N/A	N/A	1	115	15	1	0.1	8
4'	1	6.7	15	0.6	50	N/A	N/A	N/A	N/A	N/A	N/A	1	115	15	1	0.1	8
5'	2	6.7	15	1.2	100	N/A	N/A	N/A	N/A	N/A	N/A	1	115	15	1	0.1	8
6'	2	6.7	15	1.2	100	N/A	N/A	N/A	N/A	N/A	N/A	1	115	15	1	0.1	8
8'	2	6.7	15	1.2	100	N/A	N/A	N/A	N/A	N/A	N/A	1	115	15	1	0.1	8
10'	4	6.7	15	2.5	200	N/A	N/A	N/A	N/A	N/A	N/A	1	115	15	1	0.1	8
12'	3	6.7	15	1.9	150	N/A	N/A	N/A	N/A	N/A	N/A	1	115	15	1	0.1	8
45"O	2	6.7	15	1.2	100	N/A	N/A	N/A	N/A	N/A	N/A	1	115	15	1	0.1	8

OPTIONAL HIGH OUTPUT LED LIGHTS (115 VOLT)

CASE LENGTH	OPTIONAL SHELF		MAX. H.O. LED LOAD	
	AMPS	WATTS	AMPS	WATTS
2'	N/A	N/A	N/A	N/A
3'	N/A	N/A	N/A	N/A
4'	N/A	N/A	N/A	N/A
5'	N/A	N/A	N/A	N/A
6'	N/A	N/A	N/A	N/A
8'	N/A	N/A	N/A	N/A
10'	N/A	N/A	N/A	N/A
12'	N/A	N/A	N/A	N/A
45"O	N/A	N/A	N/A	N/A

## Installation

### Location

The refrigerated merchandisers have been designed for use only in air conditioned stores where temperature and humidity are maintained at or below 75°F and 55% relative humidity. DO NOT allow air conditioning, electric fans, ovens, open doors or windows (etc.) to create air currents around the merchandiser, as this will impair its correct operation.

Product temperature should always be maintained at a constant and proper temperature. This means that from the time the product is received, through storage, preparation and display, the temperature of the product must be controlled to maximize life of the product.

### Uncrating the Stand (If Provided; Crating is Optional)

Place the fixture as close to its permanent position as possible. Remove the top of the crate. Detach the walls from each other and remove from the skid. Unbolt the case from the skid. The fixture can now be lifted off the crate skid. **Lift only at base of stand!**

When crating is not provided, lift at one end panel using forklift and place a dolly under that end panel such that end panel rests in the middle of the dolly. Repeat the same procedure at the other end panel. Once the fixture is on dollies, move it carefully out of the truck. This is a recommendation only. Unloading the fixture following safe procedures is the responsibility of the company unloading and installing these fixtures.

### Exterior Loading

These models have not been structurally designed to support excessive external loading. **Do not walk on their tops;** This could cause serious personal injury and damage to the fixture.

### Setting and Joining

The sectional construction of these models enable them to be joined in line to give the effect of one continuous display. A joint trim kit is supplied with each joint.



## WARNING

- DSF glass is shipped installed to merchandiser.
- Merchandiser will arrive with shipping foam to prevent glass damage
- Cases must be set and joined prior to removal of glass shipping foam.
  - High risk of injury if glass shipping foam is removed prior to transportation and or finalizing permanent location.

### Leveling

**IMPORTANT! IT IS IMPERATIVE THAT CASES BE LEVELED FROM FRONT TO BACK AND SIDE TO SIDE PRIOR TO JOINING. A LEVEL CASE IS NECESSARY TO INSURE PROPER OPERATION, WATER DRAINAGE, GLASS ALIGNMENT, AND OPERATION OF THE HINGES SUPPORTING THE GLASS. LEVELING THE CASE CORRECTLY WILL SOLVE MOST HINGE OPERATION PROBLEMS.**

**NOTE:** A. To avoid removing concrete flooring, begin lineup leveling from the highest point of the store floor.

B. When wedges are involved in a lineup, set them first.

All cases were leveled and joined prior to shipment to insure the closest possible fit when cases are joined in the field. When joining, use a carpenters level and shim legs accordingly. Case must be raised correctly, under legs where support is best, to prevent damage to case.

## Body Panel Removal

The merchandiser's body panels are designed to be held in place without the use of fasteners for a smoother less intrusive aesthetics. The lower body panel is held in place by the lower flange of the upper front body panel located just underneath the bumper section of the case and resting hooks located at the bottom of the case which the body panel rest onto.

Follow the below steps in order to remove body panels and vice versa to re-install to the merchandiser.

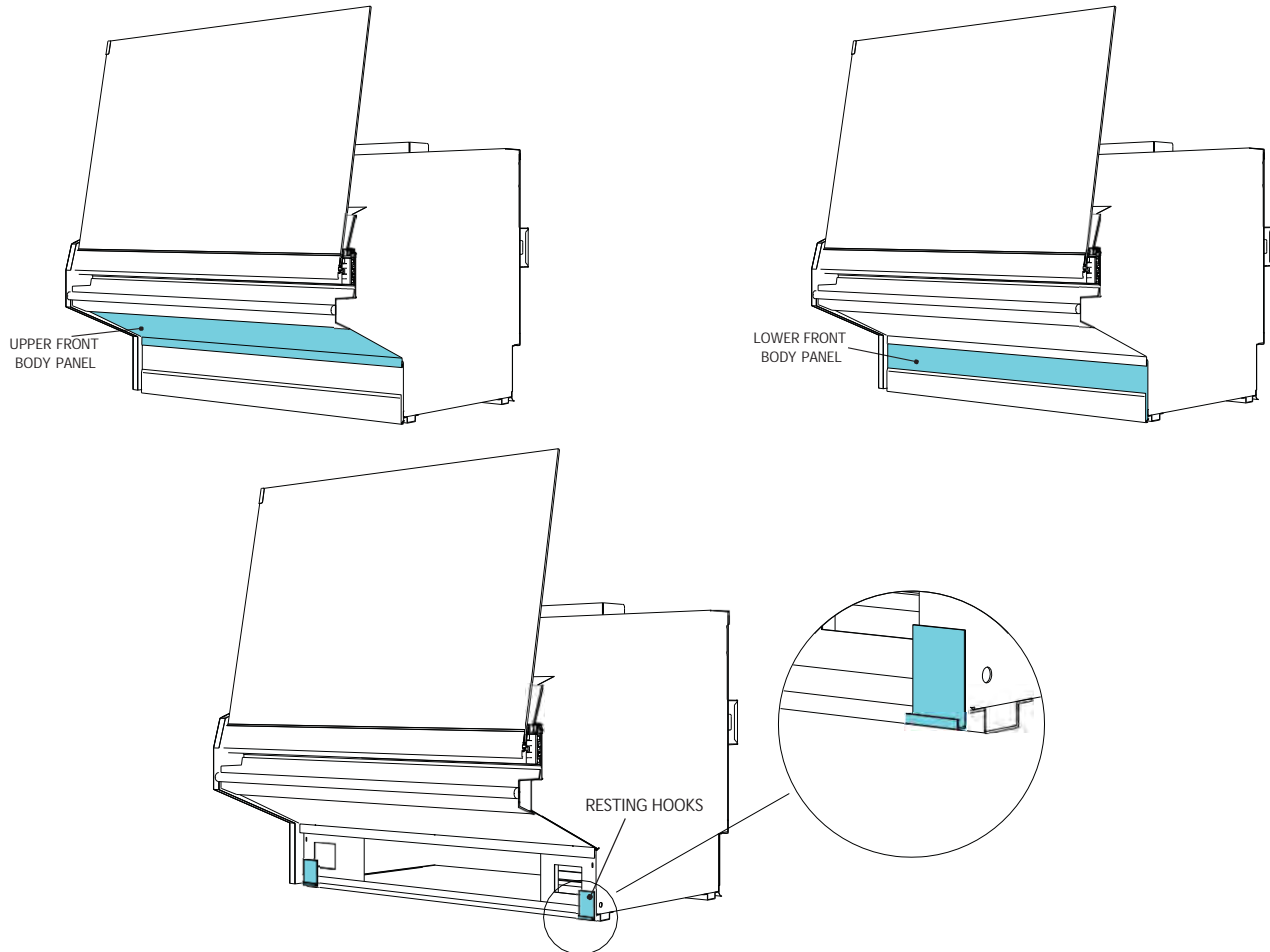

### Step 1

Raise body panel in upward motion to lift bottom channel from resting hooks at bottom of case.

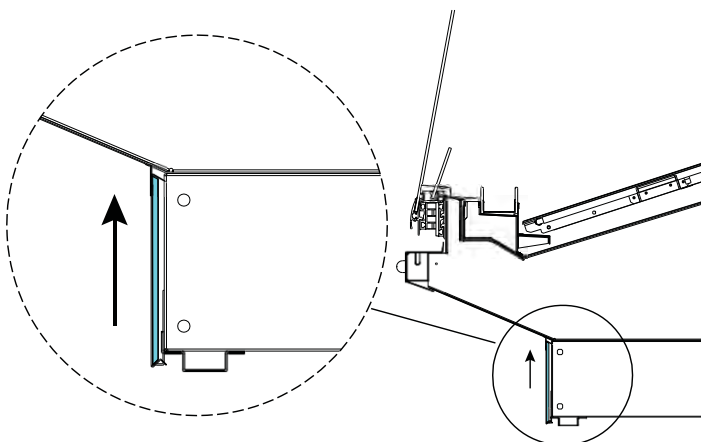

### Step 2

Pull body panel inward clearing over lower resting hooks and down to extract slots from retaining clips.

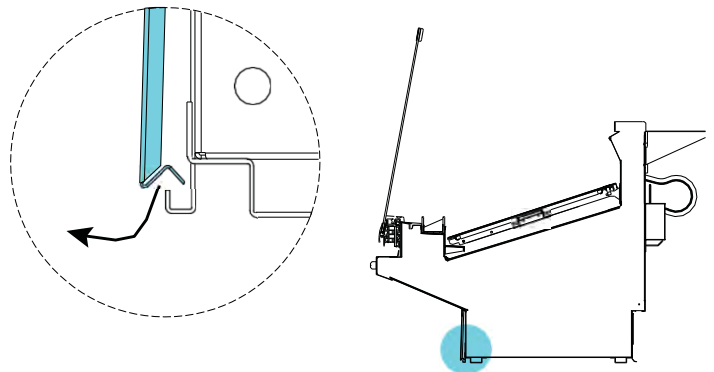

### Attach Body Panels

To attach the body panels back onto the merchandiser follow the steps in reverse order.

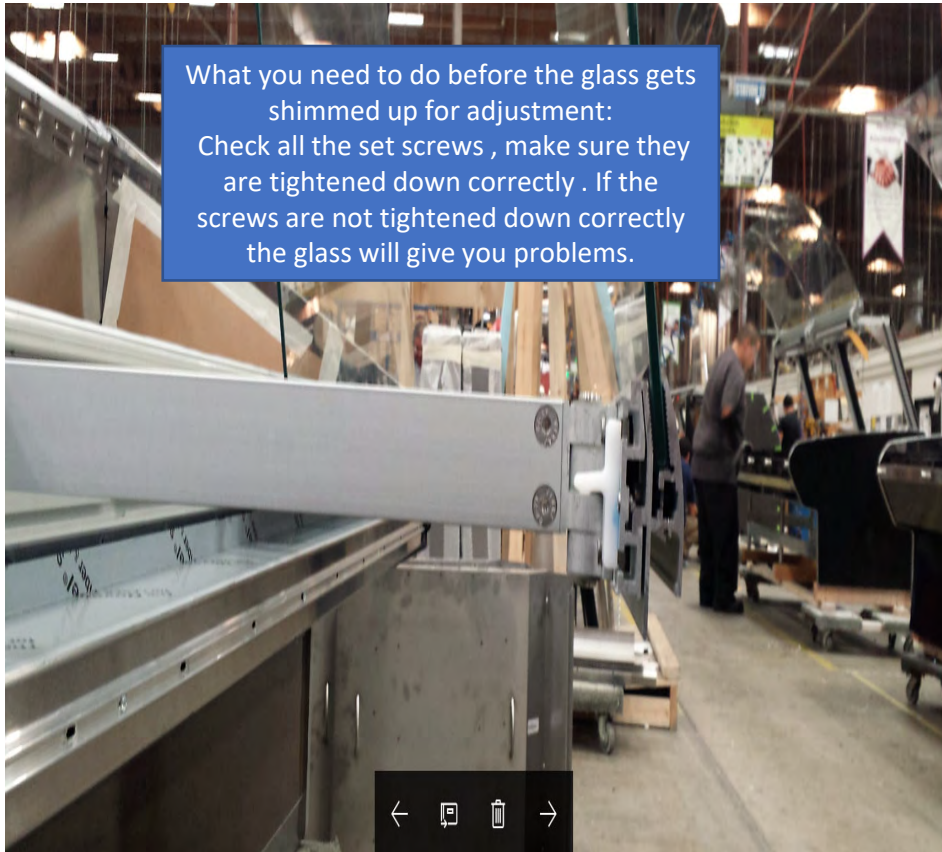

The glass and glass clamp need to be removed to check all screws for the glass clamp.

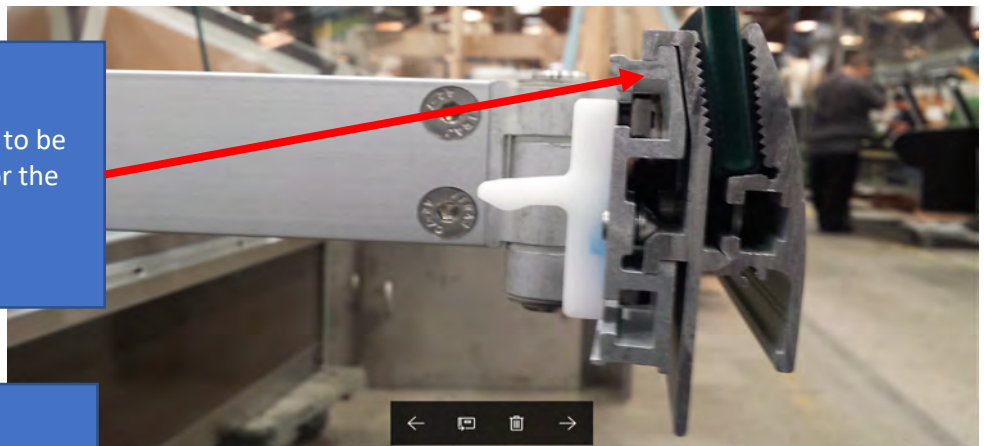

Check all the set screws on the swing arms.



What to do after the set screws are tightened down and the problem continues .  
Add a Formica shim to the glass that is not matching, if the glass is down add a shim to the inside between the glass and the glass clamp.

If the glass is high add a shim to the outside between the glass and the clamp.

If shims need to be added, the glass and glass clamp need to be removed to add the shims.

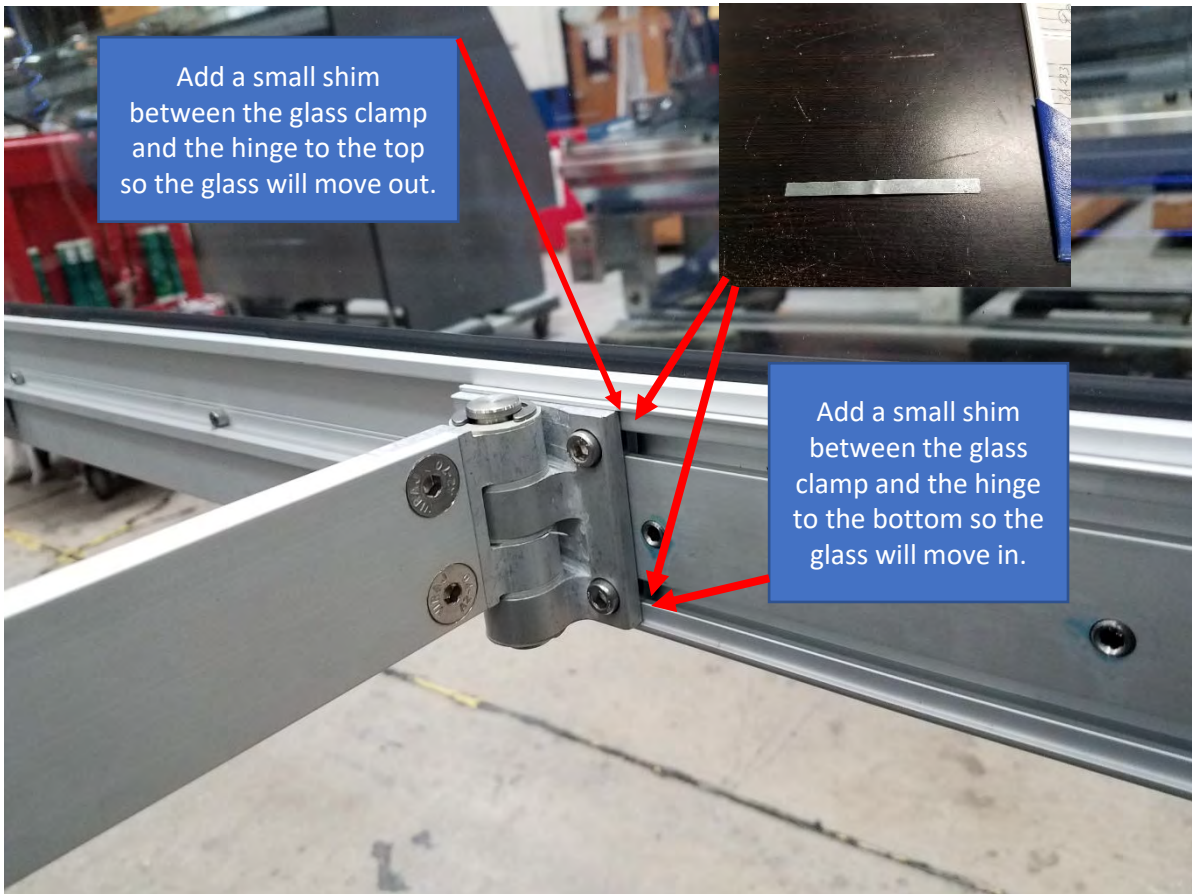
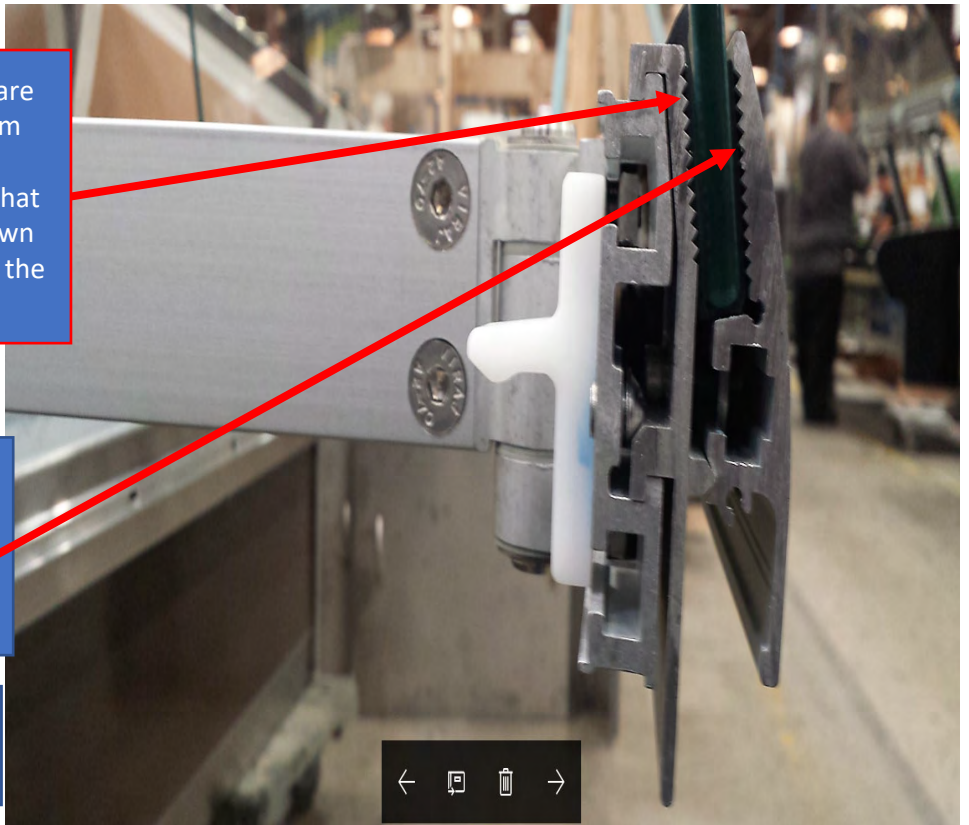

Add a small shim between the glass clamp and the hinge to the top so the glass will move out.

Add a small shim between the glass clamp and the hinge to the bottom so the glass will move in.

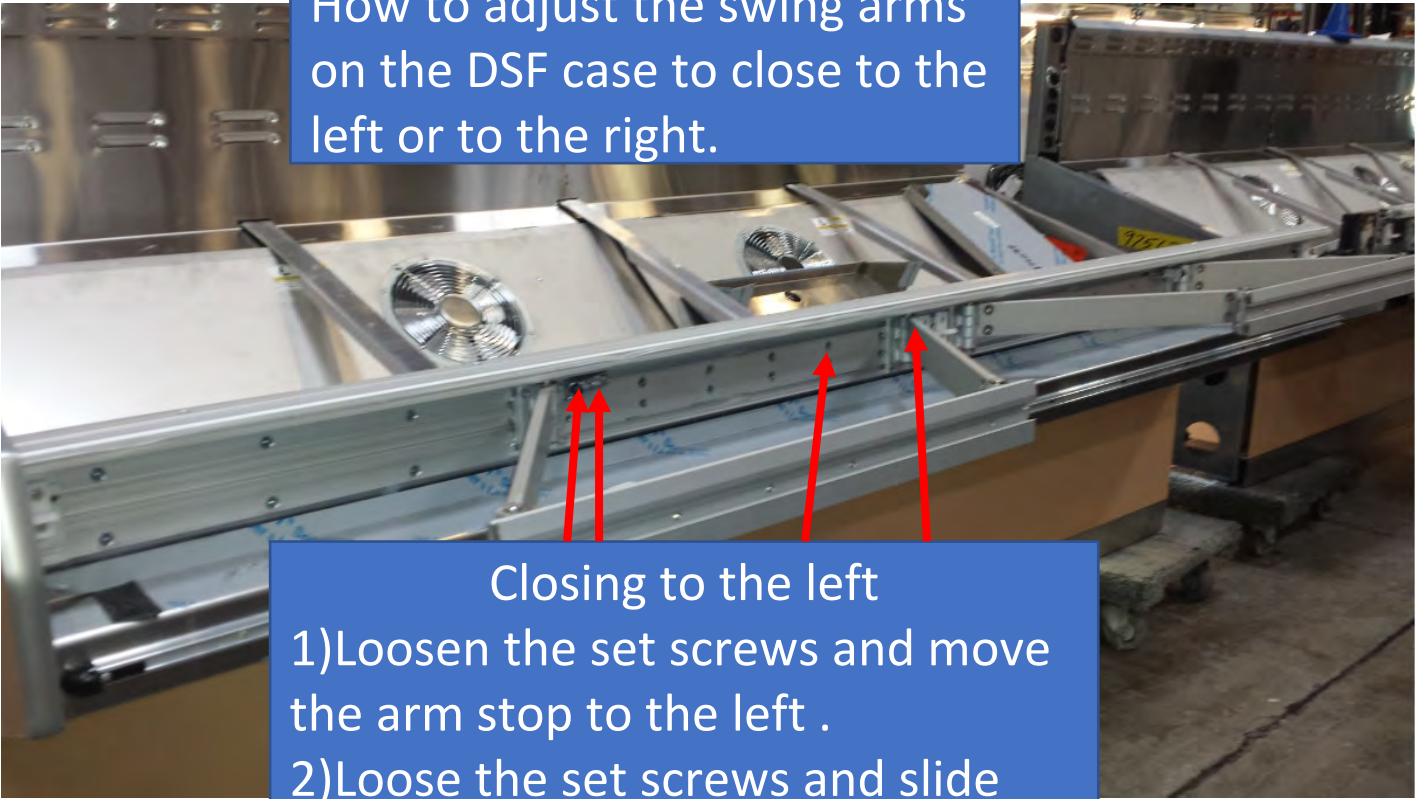

How to adjust the swing arms on the DSF case to close to the left or to the right.

Closing to the left  
1) Loosen the set screws and move the arm stop to the left .  
2) Loose the set screws and slide the swing arm to the right.

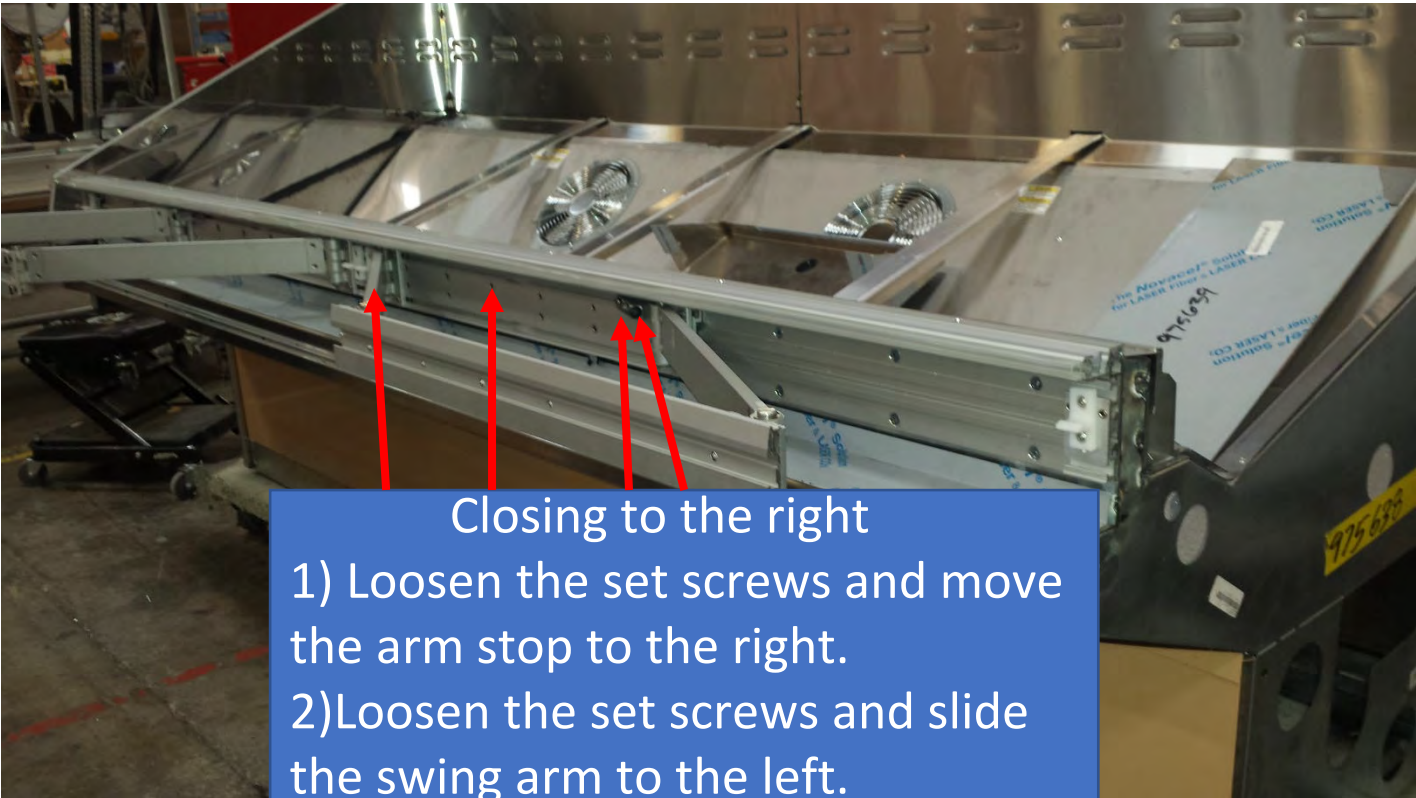

Closing to the right  
1) Loosen the set screws and move the arm stop to the right.  
2) Loosen the set screws and slide the swing arm to the left.

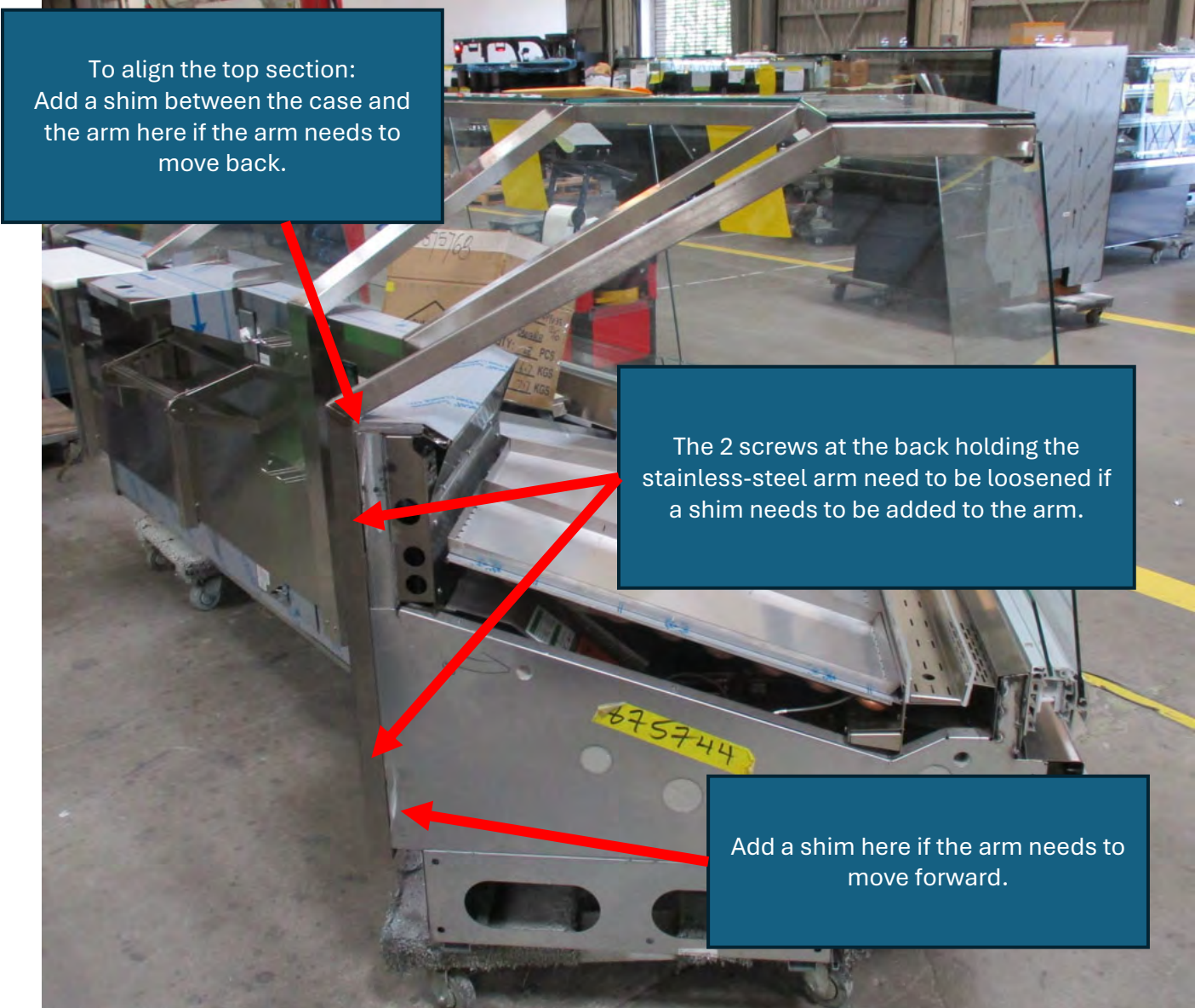

To align the top section:  
Add a shim between the case and  
the arm here if the arm needs to  
move back.

The 2 screws at the back holding the  
stainless-steel arm need to be loosened if  
a shim needs to be added to the arm.

Add a shim here if the arm needs to  
move forward.

# Lifting Instructions

## DSF Lifting and Transport Instructions

1. The DSF is not recommended to be lifted by a forklift due to critical refrigeration components underneath merchandiser.  
For the safest process defer to using J-Bars or Jacks



**Use of forklift may damage critical refrigeration components and or drainage piping. Use a spotter when placing forks. Preferable method of movement is to use J-Bars or Jacks.**

2. Remove splash guards and lower body panels before lifting with a jack. Serious damage will occur if the body panels are not removed (see pg. 16 for body panel removal).
3. The DSF can be raised at one end to allow the placement of rollers or dollies then repeated to raise opposite end.
4. Never drag or push the DSF by ANY COMPONENT including ANY GLASS. This will result in damage to the base, and possibly damage to other components and or injury/serious bodily harm.
7. Evenly support the entire base structure on rollers or dollies before attempting to move. Each Base Leg must have its own dolly to properly support the case.
8. Smaller dollies (36" or less) will require one dolly per corner at all four corners to ensure a safe transporting process

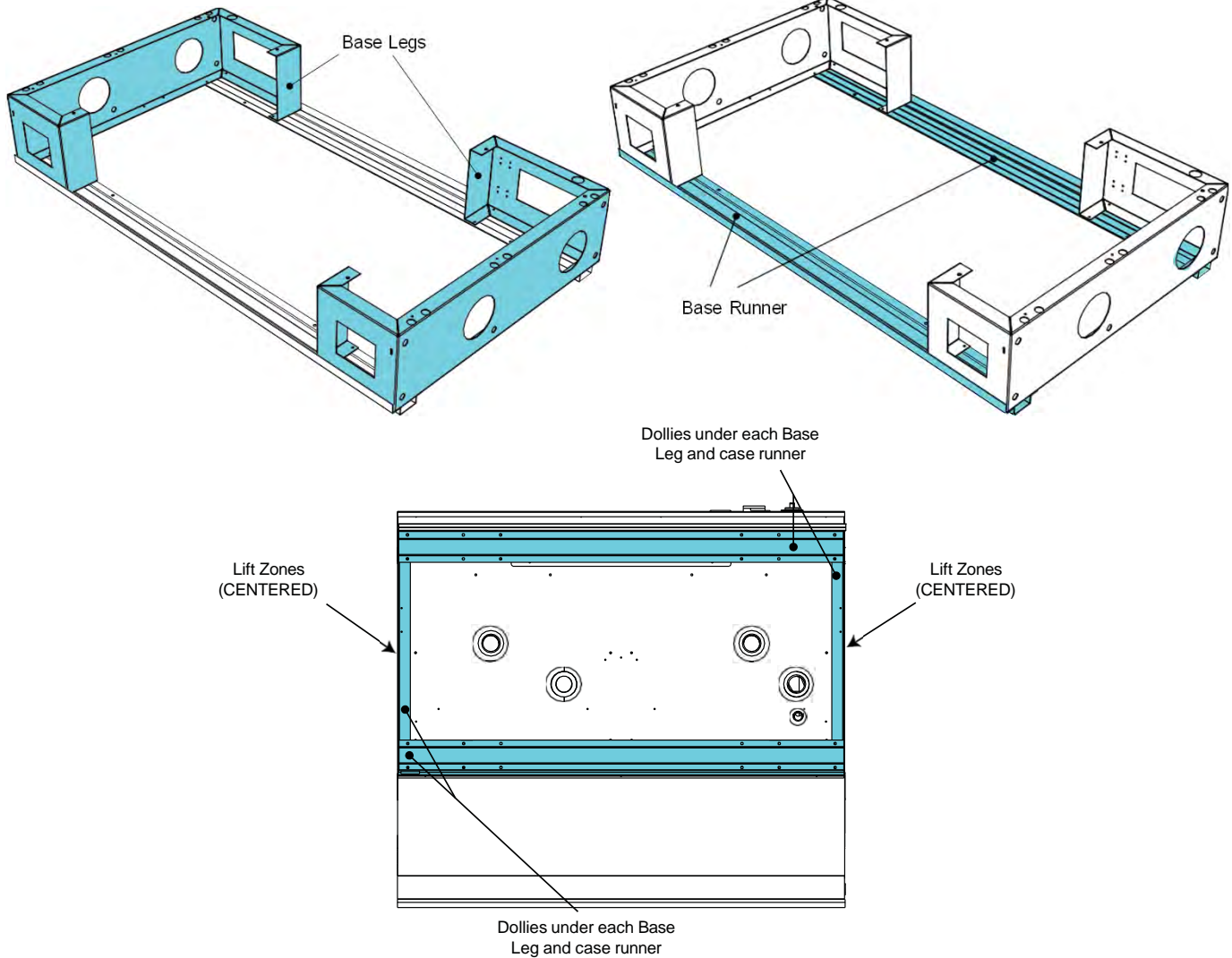

## Lifting Instructions (Cont'd)

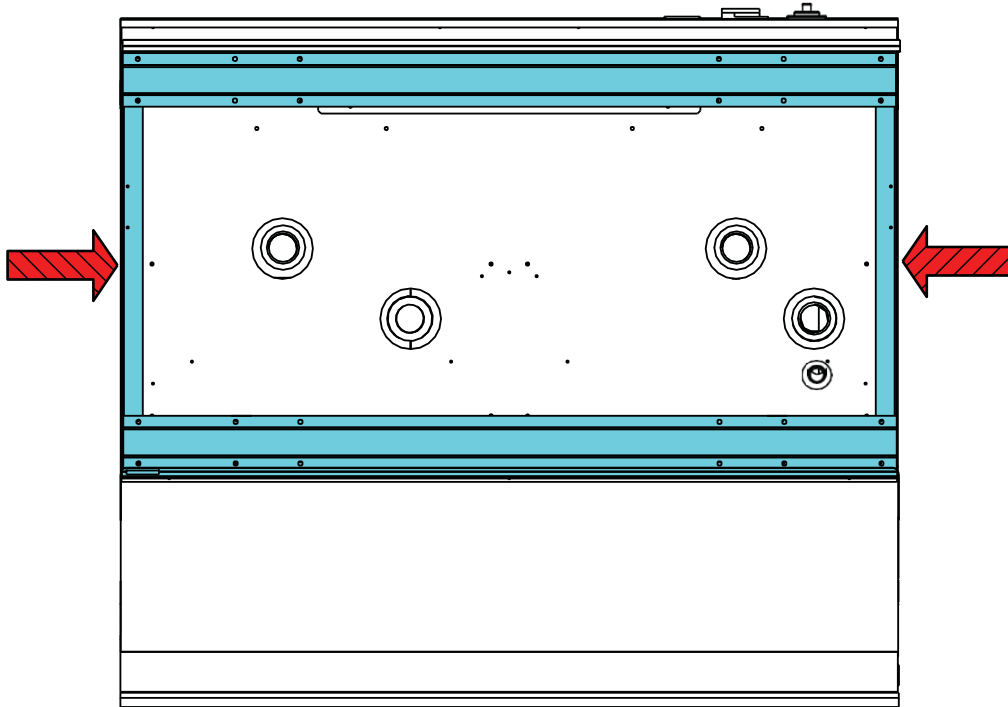

9. While using J-Bars, use the specified set points to support the case based of the size of dollies being utilized.
- Raise one end of the case first.
  - One J-Bar is usually sufficient to lift the case, use multiple J-Bars at specified lift zones if one does not satisfy the safe lift of the merchandiser.
  - Place Dollies and chock wheels before lifting the other side. Be sure that the dollies are evenly spaced to carry to weight of the case

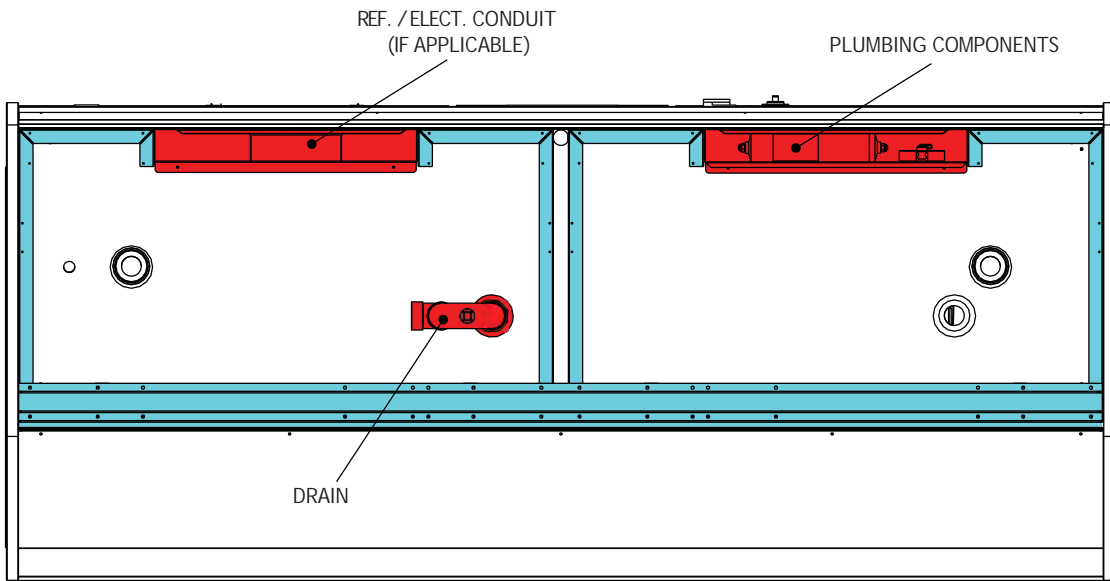

10. Avoid all contact when lifting or transporting merchandiser in order to prevent any damage to the listed critical refrigeration and electrical components.

## Plumbing

### Waste Outlet and P-TRAP

The waste outlet is located off the center of the case on one side allowing drip piping to be run lengthwise under the fixture. The water seal is factory installed. Do not tighten the water seal where it connects to the drain fitting. Twisting the water seal "trap" can cause a water leak in the case's bottom liner. Do not use thread sealant between ABS drain fitting and water seal.

P-traps must be installed at the base of all refrigerated cases. The 1 ½" P-TRAP and threaded adapter must be installed to prevent air leakage and insect entrance into the fixture.



### WARNING

The drain and water seal are factory installed.  
**DO NOT** use thread sealant or over-tighten these parts.  
**DO NOT** twist water seal. Damage to the drain fitting or water seal may occur if overtightened or incorrectly tampered with.

# WARNING!

**Do NOT apply thread sealer to ABS P-Trap.**



### Installing Condensate Drain

Poorly or improperly installed condensate drains can seriously interfere with the operation of this refrigerator, and result in costly maintenance and product losses. Please follow the recommendations listed below when installing condensate drains to insure a proper installation:

1. Never use pipe for condensate drains smaller than the nominal diameter of the pipe or P-TRAP supplied with the case.
2. When connecting condensate drains, the P-TRAP must be used as part of the condensate drain to prevent air leakage or insect entrance. Store plumbing system floor drains should be at least 14" off the center of the case to allow use of the P-TRAP pipe section. Never use two water seals in series in any one line. Double P-TRAPS in series will cause a lock and prevent draining.
3. Always provide as much down hill slope ("fall") as possible; 1/8" per foot is the preferred minimum. PVC pipe, when used, must be supported to maintain the 1/8" pitch and to prevent warping.
4. Avoid long runs of condensate drains. Long runs make it impossible to provide the "fall" necessary for good drainage.
5. Provide a suitable air break between the flood rim of the floor drain and outlet of condensate drain. 1" is ideal.
6. Prevent condensate drains from freezing:
  - a. Do not install condensate drains in contact with non-insulated suction lines. Suction lines should be insulated with a non absorbent insulation material such as Armstrong's Armaflex.
  - b. Where condensate drains are located in dead air spaces (between refrigerators or between a refrigerator and a wall), provide means to prevent freezing. The water seal should be insulated to prevent condensation.

# Humidification

## General Description

One contributor to the spoilage of fresh meats is dehydration, which causes loss in weight and volume (shrinkage) and product discoloration. As the refrigeration system removes heat from the case, it also removes critical moisture from the air, and any unwrapped products in the case. The Humidity System replaces the moisture in the air, in order to compensate for the moisture taken by the refrigeration system, and disposed of down the drain line. The system is built into the discharge plenum, and mixes moisture laden air with refrigerated air before the air is passed through - and around the product.

The system is constructed almost entirely of PVC pipe, and uses air that is sub-cooled to approximately the same temperature as the case. The sub-cooling of air inhibits the formation of growth found to be a problem in other humidification systems. Maintenance is almost unnecessary if you follow a few simple rules:

1. Keep the case clean.
2. Keep the water filter clean, and change it every six to twelve months or sooner, depending on the kind of water found in your area.
3. Flush the header every six (6) months, by loosening the connecting "L", then removing it from the case, and flushing with a hose.



### IMPORTANT INFORMATION

**The DSF is capable of maintaining superb product quality with the installation of the proper controlling devices. These devices should be set according to the Hussmann's specifications. The humidity system should be properly maintained. Incorrect settings and failure to maintain the humidity system will result in short product life. Below are a few guidelines for optimum performance and product life:**

- Set thermostat to cut in at the discharge temperature designated in the case specifications section of the appropriate installation guide or specification sheet. Maintain the recommended product temperature for Deli, Meat, and Fish. DO NOT set temperature too cold, as this causes product dehydration.
- Temperatures should be achieved by means of a T-STAT and Suction Solenoid at each case. DO NOT use EPR valves, Liquid Line Solenoids, or electronic control devices of any kind. These controls allow temperature swings that cause dehydration and excessive energy consumption.
- Set defrost cycles as listed in the Case Specifications Data for your particular case. The number of defrosts per day should never change. The duration of the defrost cycle may be adjusted to meet conditions present at your location.

- Clean humidity system a minimum of every 90 days for proper system operation.
- Work and rotate product - not to exceed a four (4) hour period.
- At night, turn off case lights, and cover unwrapped product with moistened cheesecloth or fabric towels.
- Keep meat holding box at 32°F.
- Keep meat prep room refrigerated at 55°F.
- Meat Bloom Box (if applicable) should be at 36°F.
- Meat must enter the case at 40°F or below. Product deteriorates rapidly above 40°F.
- Clean, sanitary conditions are required throughout the meat holding, prep, and work areas.
- Do not display product directly within the air discharge
- Turn and rotate meat. The blood works down through the meat over time, which causes the top surface to discolor and dehydrate. Turn meat 3-4 times per day.
- It is not required to remove product from case overnight. Turn off case lights, and cover product with moistened cheesecloth or fabric towel. This helps slow down product dehydration, by taking moisture from the cloth and not the product. This is an old method used by meat shops for many years, as it extends product life.
- Cold coils remove heat and moisture from the case and deposit this as frost onto the coil. Thus a defrost is required to remove this frost. Our humidity system induces moisture into the case, and helps slow down the dehydration process. The only other moisture in the case is that which is in the product. A single level of meat will dry out faster than a fully loaded case with 3-4 levels of meat.
- The colder the case, the faster the product loses its moisture and shelf life. It is very important to maintain a constant, even, correct, product temperature.

## Humidification System Hookups

Remove the raceway panel on the lower back of the case. The pre-piped water shut-off valve and the water filter are located on the left hand side of the case. The water line (which is a 1/4" OD copper fitting) can be connected to the ball shut-off valve, by means of a compression fitting (supplied). The line should be one size larger than the supply line. The line can then be run from one case to another from within the raceway(s) using Tee connectors. Before connecting the water to the humidity system, it is best to purge the line to flush any debris that may clog the water filter. If the water line requires purging after the cases are hooked together, it is not necessary to check each one. Simply shut ball valves to each humidity system, remove the water line from the last case in the flow, and purge. By doing this as a precautionary measure, you may avoid problems and repeat servicing.

# Manifold Flush System

## Start-up

Turn on the fan circuit. Check to see if the fan for the humidity system is running. Remove the right hand bottom pan (when facing the front of the case), then the TXV cover. The fan is located up against the right hand side of the case, as viewed from the front, under the fan plenum (see diagram). View the blade, and make sure the fan rotation agrees with the air flow arrows. Turn on the water, by turning the ball valve in the direction of the flow (OFF is at 90° to the direction of flow).

After a few minutes, check the spray header by sliding the honeycomb to the left to expose the discharge tube located on the right hand side of the case (when viewed from the rear), by lifting the 4'-0" section of honeycomb with both ends, until the bottom clears. Pull up and set aside. The spray header will be exposed. Grasp the header and pull it loose from the 90° "L" until you see the misting nozzle, which should be spraying. If not, check the following:

1. Make sure the water is feeding the nozzle.
2. Remove the nozzle, and purge the water.
3. Check strainer at entrance to nozzle.

Reinsert the header into the 90° "L", making sure that the nozzle is in the center of the pipe when totally inserted, and the holes in the header are facing the front of the case at a level angle. The discharge tube can easily be pulled to service.

## Maintenance

- Clean humidity system a minimum of every 90 days for proper system operation.

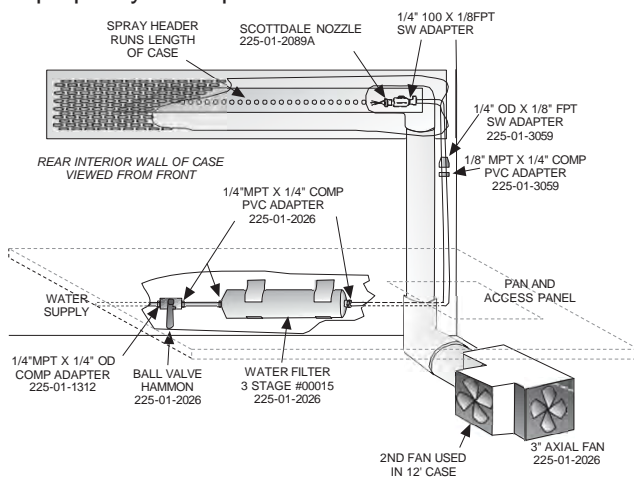

HUMIDITY SYSTEM as viewed from the front.

**Note:** The axial fans included in the humidity system must be replaced as a unit.

## General Description

Twice a day for two (2) minutes, a high pressure water stream will flush most residue build-up from the bottom of the manifold chamber. This is the area that residue builds and expands from. Frequency of this periodic maintenance will vary depending on water mineral content and sanitary conditions.

### Automatic Flush System

Electrical components are located within the electrical raceway. Electrical components in this area are 115V AC. Step-down transformer is located in wire-way, and is controlled by pump switch. Water flow for flush system is rated at 0.25 GPM at 60PSI water pressure. Flush nozzle located in the rear of the case.

### Basic System Operation:

1. Filtered water is supplied to the 115V solenoid valve.
2. At a time of day determined by you, the 115V time clock will energize the solenoid for 2 minutes.

### Start Up:

1. Manually move time clock to initiate a flush cycle.
2. Observe that flush nozzle is spraying down center of manifold chamber.
3. Set clock to correct time of day.
4. Set trip pins to the "time of day system is to flush"  
(NOTE: 2 flush/day!)

## Manual Flush System

Water valve is located on the outside of the case, in the rear, on the left hand side as viewed from the rear.

# Refrigeration

## Refrigerant Type

The standard refrigerant will be specified on the customer order. Check the serial plate on the case for information.

## Piping

The refrigerant line outlets are located under the case. Locate first the electrical box, the outlets are then on the same side of the case but at the opposite end. Insulate suction lines to prevent condensation drippage.

## Refrigeration Lines

<u>Liquid</u>	<u>Suction</u>
3/8" O.D.	5/8" O.D.

**NOTE:** The standard coil is piped at 5/8" (suction); however, the store tie-in may vary depending on the number of coils and the draw the case has. Depending on the case setup, the connecting point in the store may be 5/8", 7/8", or 1 1/8". Refer to the particular case you are hooking up.

Refrigerant lines should be sized as shown on the refrigeration legend furnished by the store.

Oil traps must be installed at the base of all suction line vertical risers on refrigerated cases.

**Pressure drop** can rob the system of capacity. To keep the pressure drop to a minimum, keep refrigerant line run as short as possible, using the minimum number of elbows. Where elbows are required, use long radius elbows only.

## Control Settings

See DSF, DSFM technical data sheet for the appropriate settings for your merchandiser. Maintain these parameters to achieve near constant product temperatures. Product temperature should be measured first thing in the morning, after having been refrigerated overnight. For all multiplexing, defrost should be time terminated. Defrost times should be as directed in the DSF, DSFM technical data sheet. The number of defrosts per day should never change. The duration of the defrost cycle may be adjusted to meet conditions present at your location.

## Access to TX Valves and Drain Lines

**Mechanical** - Remove product from end of case. Remove product racks. Remove refrigeration and drain access panels (labeled). TX valve (mechanical only) and drain are located under each access panel at end of the case.

**Electronic** - The Electronic Expansion valve master and slave cylinder(s) are located within the electrical access panel(s).

## Electronic Expansion Valve (Optional)

A wide variety of electronic expansion valves and case controllers can be utilized. Please refer to EEV and controller manufacturers information sheet. Sensors for electronic expansion valves will be installed on the coil inlet, coil outlet, and in the discharge air. (Some supermarkets require a 4th sensor in the return air). Case controllers will be located in the electrical raceway or under the case.

## Thermostatic Expansion Valve

### Location

This device is located on the same side as the refrigeration stub. A balanced port expansion valve model is furnished as standard equipment, unless otherwise specified by customer.

### Expansion Valve Adjustment

Expansion valves must be adjusted to fully feed the evaporator. Before attempting any adjustments, make sure the evaporator is either clear or very lightly covered with frost, and that the fixture is within 10°F of its expected operating temperature.

## Measuring the Operating Superheat

1. Determine the suction pressure with an accurate pressure gauge at the evaporator outlet.
2. From a refrigerant pressure temperature chart, determine the saturation temperature at the observed suction pressure.
3. Measure the temperature of the suction gas at the thermostatic remote bulb location.
4. Subtract the saturation temperature obtained in step No. 2 from the temperature measured in step No. 3.
5. The difference is superheat.
6. Set the superheat for 5°F - 7°F.

## T-STAT Location

T-STATS are located within the electrical raceway of the 4' or 5' main section of the case. In all the cases, the T-STAT is located on the same side of the case. If you are looking at the case from the back, it is on the left hand side.

# Electrical

## Standard Case Wire Color Code

Color Description	Color
■ Ground .....	Green
■ Anti-Sweat .....	Purple
■ Lights .....	Orange
■ Receptacles .....	Yellow
■ T-Stat/Solenoid 230VAC .....	Red/Black
■ T-Stat/Solenoid 115VAC .....	White/Black
■ T-Stat/Solenoid 24VAC .....	Red/White
■ Fan Motors .....	Brown
■ Blue Condensing Unit	

Use Copper Conductors Only  
430-01-0338 R101003

### CASE MUST BE GROUNDED

**NOTE:** Refer to label affixed to case to determine the actual configuration as checked in the "TYPE INSTALLED" boxes.

Standard lighting for all refrigerated models will be full length LED Lights located within the case at the top.

## Field Wiring and Serial Plate Amperage

Field Wiring must be sized for component amperes printed on the serial plate. Actual ampere draw may be less than specified. Field wiring from the refrigeration control panel to the merchandisers is required for refrigeration thermostats. Case amperes are listed on the wiring diagram, but always check the serial plate.



**DANGER**

**BEFORE SERVICING**  
**ALWAYS DISCONNECT ELECTRICAL**  
**POWER AT THE MAIN DISCONNECT**  
**WHEN SERVICING OR REPLACING ANY**  
**ELECTRICAL COMPONENT.**

**This includes (but not limited to) Fans, Heaters**  
**Thermostats, and Lights.**

## Electrical Components Location

Electrical components (if applicable) will be located in the lower rear raceway of the DSF merchandiser.

1. Remove free-floating splashguard away from case.
2. Elect. / Refer. panels are designed with simple slide in and rest designs. Lift conduit panels up and away from case to gain access to conduits.

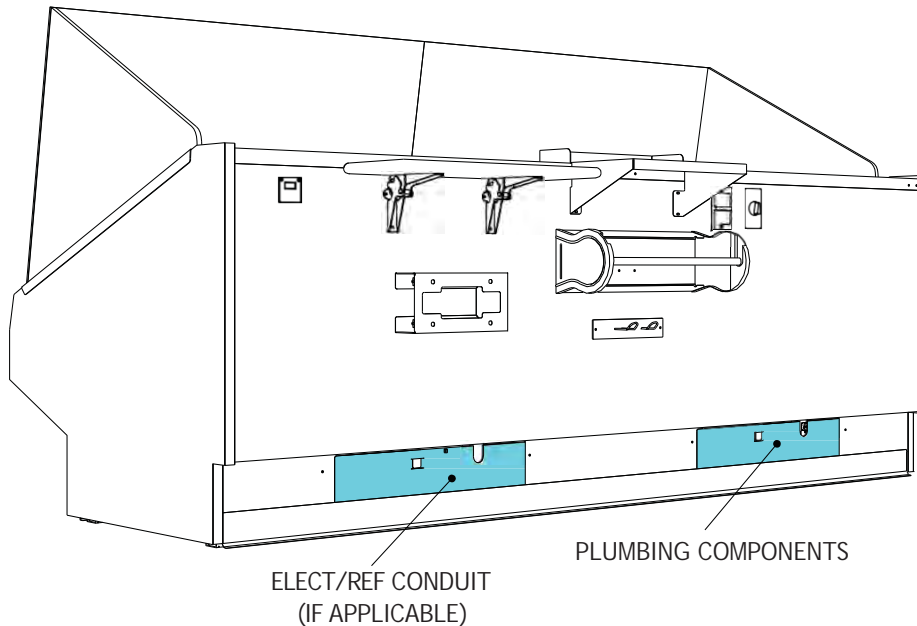

## Electrical Wiring Diagram Index

<b>DSFM</b>	DSFM-4-R	4'	3031547
	DSFM-5-R	5'	3041020
	DSFM-6-R	6'	3031548
	DSFM-8-R	8'	3031549
	DSFM-10-R	10'	3031550
	DSFM-12-R	12'	3031551
<b>DSFN-EP</b>	DSFN-EP-2-R	2'	3063099
	DSFN-EP-3-R	3'	3063097
	DSFN-EP-5-R	5'	3063096
	DSFN-EP-6-R	6'	3081699
	DSFN-EP-8-R	8'	3067227
	DSFN-EP-10-R	10'	3077613
	DSFN-EP-45O-R		3063100
<b>DSFN/M-EP</b>	DSFN/M-EP-CNP-6R W/LIGHTS & TIMER	6'	3149539
	DSFM-8-EP-R W/TIMER SWITCH	8'	3114302
	DSFN/M-EP-CNP-8-R W/LIGHTS & TIMER	8'	3157522
	DSFN/M-EP-CNP-10R W/LIGHTS & TIMER	10'	3149540
	DSFN/M-EP-CNP-45OR W/LIGHTS & TIMER		3149541

CIRCUIT #1			
LOADING	120V		
	L1	L5	

REVISION HISTORY			
REV	EN	DATE	REV BY / CHD BY / APPR BY
1	ECN-CAP-0007286	2018/04/18	CB / CB / CB
2	ECN-CAP-0009101	2017/09/24	CB / CB / CB

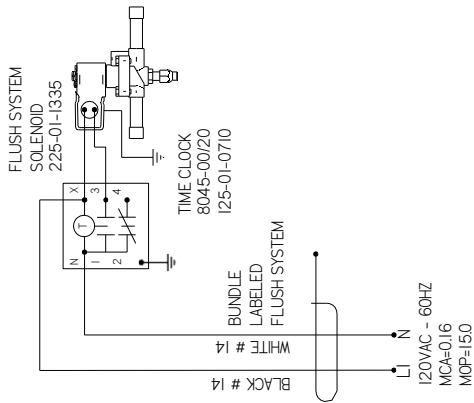
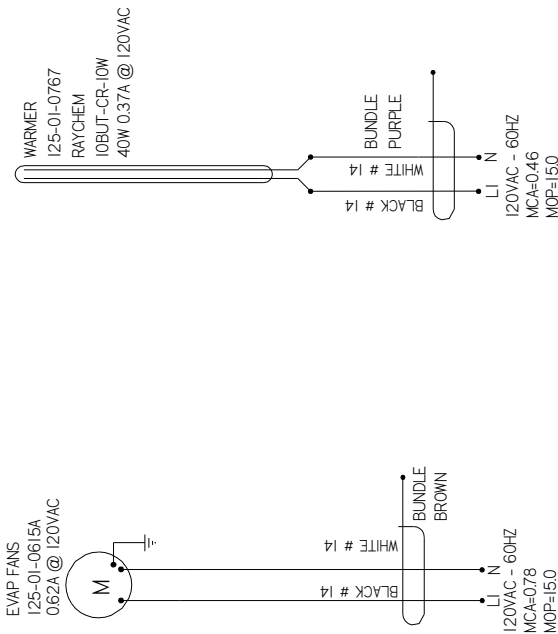
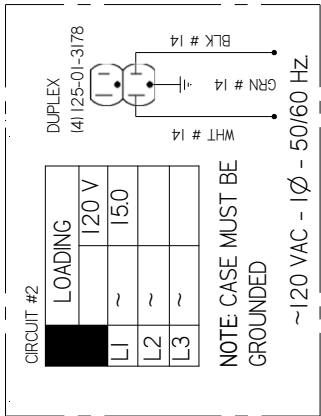

MATERIAL - NA	
DATE DRAWN - 4-18-17	ECN-CAP-0007286
DRAWN BY - CRAIG BOOREY	REF -
REVIEWED BY - CRAIG BOOREY	SHEET 1 OF 1
APPROVED BY - CRAIG BOOREY	THIRD
UNLESS OTHERWISE SPECIFIED DIMENSIONS ARE IN INCHES. TOLERANCES ARE:	
DECIMALS .XX +0.3 .XXX +0.10	ANGL
ANGLES ± 2°	E

<b>HUSSMANN</b>	
<b>DIAGRAM-DSFM-4-R</b>	
3031547	
PROJECTION	

NOTES:  
CASE MUST BE GROUNDED  
WHEN PASSING WIRES THROUGH METAL HOLES A GROMMET MUST BE USED

CIRCUIT #1	LOADING
L1	15
L2	
L3	

REV	EN	DATE	REVISION DESCRIPTION	REV BY	CHK BY	APPR BY
1	ECN-CAP-000909E	2017/06/03	RELEASED TO PRODUCTION	CB	CB	CB
2	ECN-CAP-0009010	2017/06/24	REMOVED SOLENOID PART NUMBER	CB	CB	CB

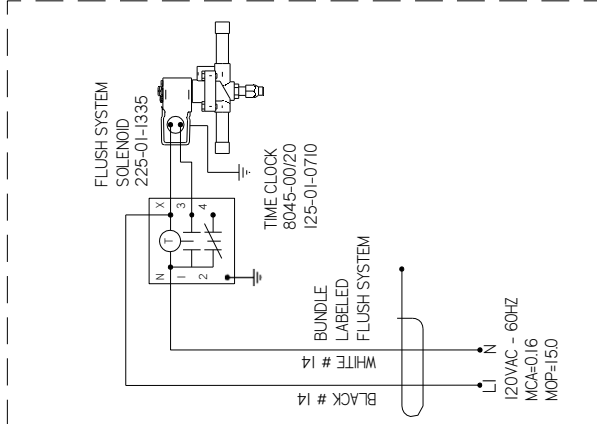
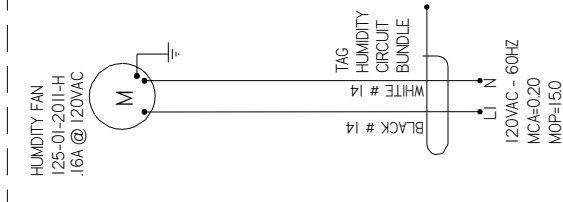
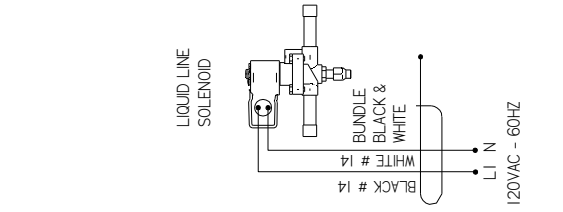
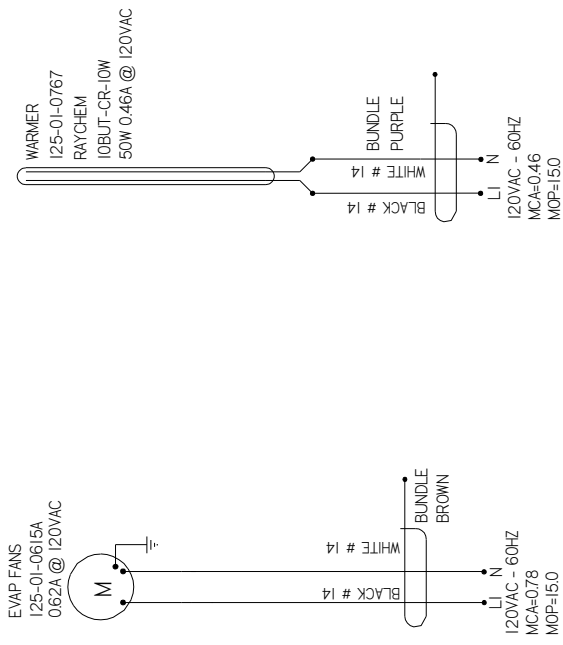
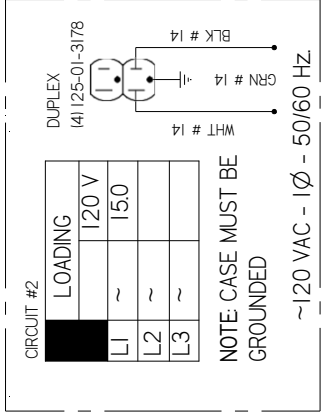

MATERIAL - NA

DATE DRAWN - 8-3-17

DRAWN BY - CRAIG BOOREY

REVIEWED BY - CRAIG BOOREY

APPROVED BY - CRAIG BOOREY

UNLESS OTHERWISE SPECIFIED DIMENSIONS ARE IN INCHES

TOLERANCES ARE:

DECIMALS .XX +0.3 .XXX +0.10

ANGLES ± 2°

PROJECTION

**HUSSMANN**

**DIAGRAM-DSFM-5-R**

ECN-CAP-000909E

REF -

SHEET 1 OF 1

THIRD

ANG

3041020

B

NOTES:  
CASE MUST BE GROUNDED  
WHEN PASSING WIRES THROUGH METAL HOLES A GROMMET MUST BE USED

CIRCUIT #1			
LOADING	120V		
	L1	L2	L3

REVISION HISTORY			
REV	EN	DATE	REV BY / CHD BY / APPR BY
1	ECN-CAP-0007286	2018/04/18	CB / CB / CB
2	ECN-CAP-0009101	2017/06/24	CB / CB / CB

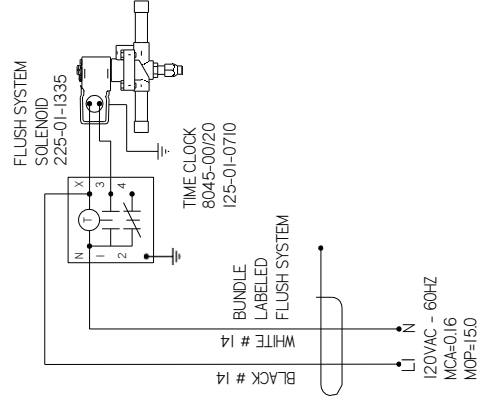
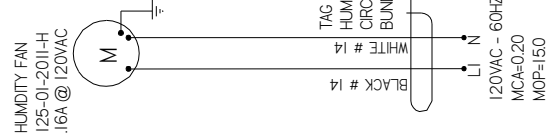
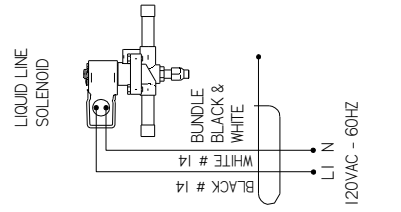
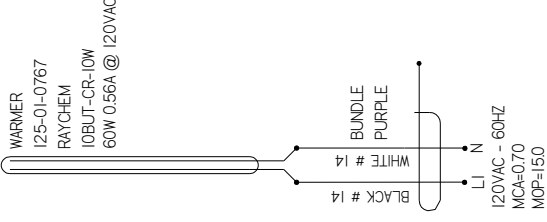
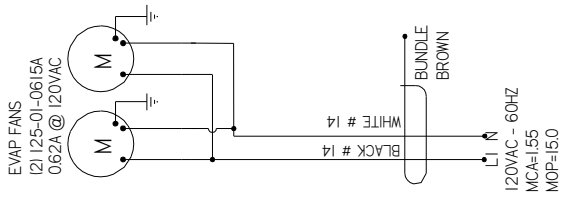
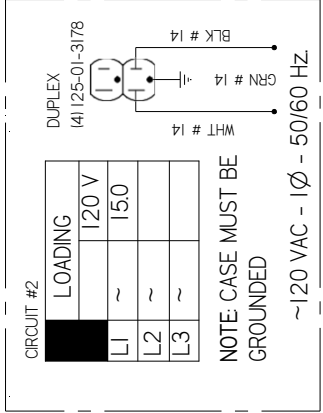

MATERIAL - NA	
DATE DRAWN - 4-18-17	ECN-CAP-0007286
DRAWN BY - CRAIG BOOREY	REF -
REVIEWED BY - CRAIG BOOREY	SHEET 1 OF 1
APPROVED BY - CRAIG BOOREY	UNLESS OTHERWISE SPECIFIED DIMENSIONS ARE IN INCHES
	TOLERANCES ARE:
	THIRD
DECIMALS .XX +0.3 .XXX +0.10	ANGL
	E
	PROJECTION

**HUSSMANN**  
**DIAGRAM-DSFM-6-R**

3031548

B

NOTES:  
CASE MUST BE GROUNDED  
WHEN PASSING WIRES THROUGH METAL HOLES A GROMMET MUST BE USED

CIRCUIT #1

LOADING	
120V	
L1	
L2	
L3	

REV	EN	DATE	REVISION HISTORY	REV BY	CHK BY	APP BY
A	ECN-CAP-0007286	20170418	RELEASED TO PRODUCTION	CB	CB	CB
B	ECN-CAP-0008109	20170824	REMOVED SOLENOID PART NUMBER	CB	CB	CB
C	ECN-CAP-008245	20180717	MADE PARTS OPTIONAL	CB	CB	CB

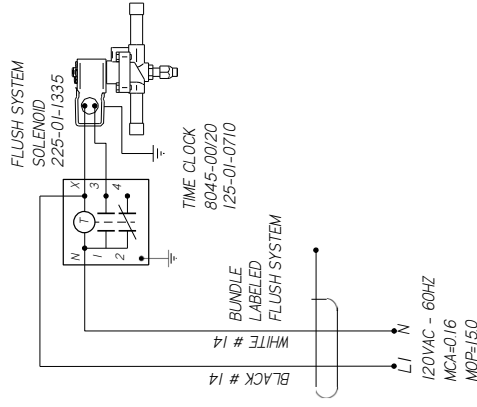
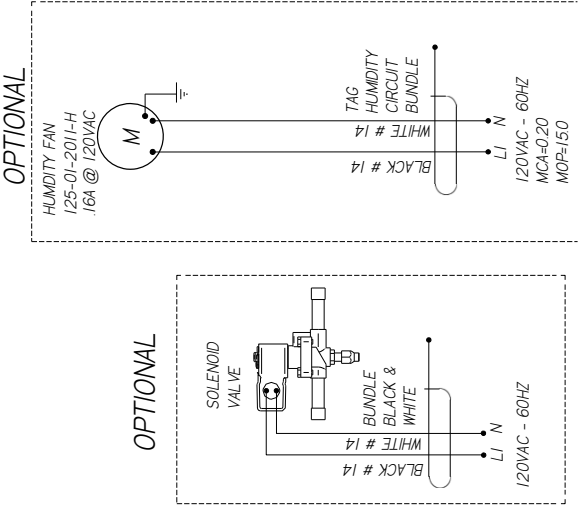
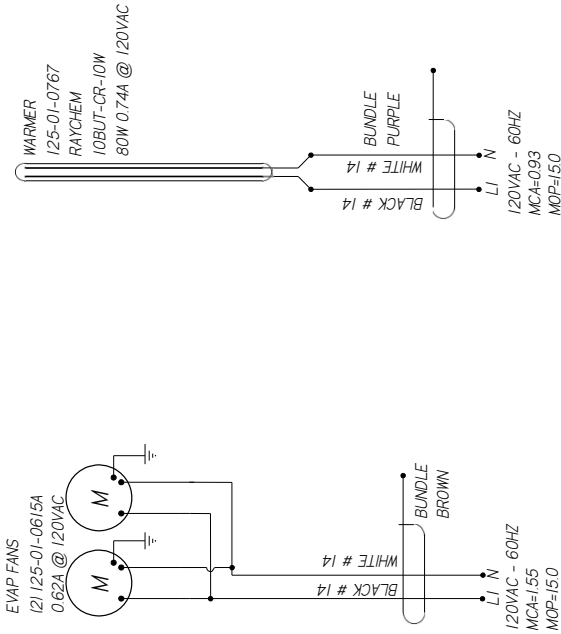
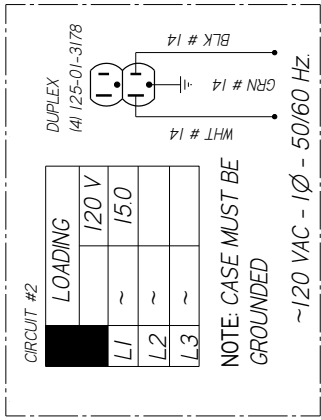

NOTES:  
CASE MUST BE GROUNDED  
WHEN PASSING WIRES THROUGH METAL HOLES A GROMMET MUST BE USED

MATERIAL - N/A  
DATE DRAWN - 4-18-17  
DRAWN BY - CRAIG BOOREY  
REVIEWED BY - CRAIG BOOREY  
APPROVED BY - CRAIG BOOREY  
UNLESS OTHERWISE SPECIFIED DIMENSIONS ARE IN INCHES  
TOLERANCES ARE:  
DECIMALS .XX ±0.3 .XXX  
±0.0  
ANGLES ± 2°  
PROJECTION  
E  
ANG  
THIR  
SHEET LOF  
REF -  
ECN-CAP-0007286  
DIAGRAM-DSFM-8-R

3031549 | C





CIRCUIT #1

LOADING	
120V	
L1	
L2	
L3	

REVISION HISTORY						
REV	EN	DATE	DESCRIPTION	REV BY	CHK BY	APP BY
A	ECN-CAP-0007286	20170617	RELEASED TO PRODUCTION	CB	CB	CB
B	ECN-CAP-0008097	20170814	CHANGED HUMIDITY FAN QTY	CB	CB	CB
C	ECN-CAP-0008107	20170824	REMOVED SOLENOID PART NUMBER	CB	CB	CB
D	ECN-CAP-0018245	20180717	MADE PARTS OPTIONAL	CB	CB	CB

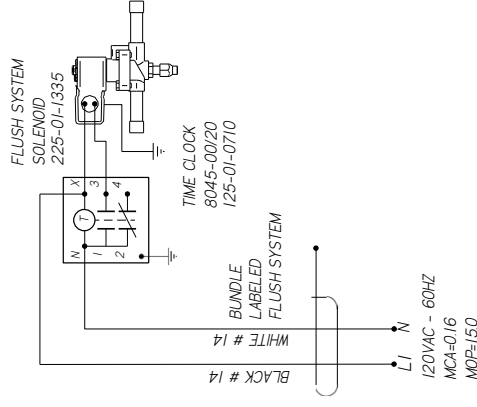
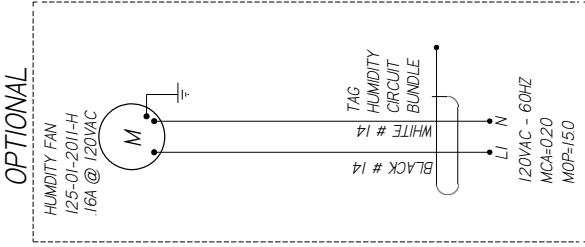
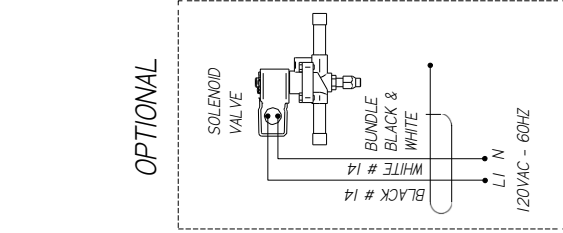
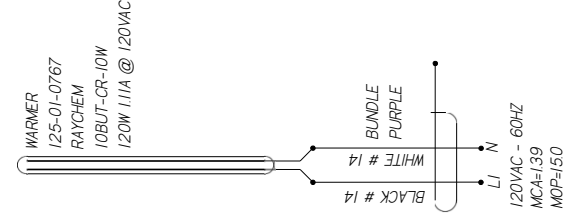
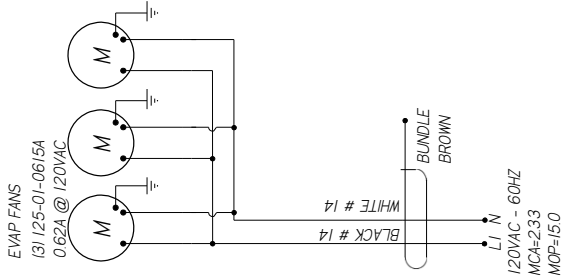
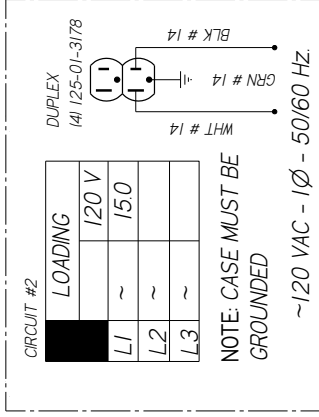

MATERIAL - N/A  
DATE DRAWN - 4-17-17  
DRAWN BY - CRAIG BOOREY  
REVIEWED BY - CRAIG BOOREY  
APPROVED BY - CRAIG BOOREY  
UNLESS OTHERWISE SPECIFIED DIMENSIONS ARE IN INCHES  
TOLERANCES ARE:  
DECIMALS .XX ±0.3 .XXX  
±0.0  
ANGLES ± 2°

ECN-CAP-0007286  
REF -  
SHEET 1 OF 1  
DIMENSIONS ARE IN INCHES  
THIRD ANGLE PROJECTION

**HUSSMANN**  
DIAGRAM-DSFM-12-R

3031551 | D

NOTES:  
CASE MUST BE GROUNDED  
WHEN PASSING WIRES THROUGH METAL HOLES A GROMMET MUST BE USED



REVISION HISTORY		REV	BY	CHG	BY	APP	BY
REV	EN	DATE	DESCRIPTION	CB	CB	CB	CB
A	EON-CAP-0012694	2018/05/16	RELEASED TO PRODUCTION	CB	CB	CB	CB
B	EON-CAP-0012694	2018/05/24	ADDED DIGITAL T-STATS	CB	CB	CB	CB

CIRCUIT #1	LOADING	120V	150V

THERMAL SIMPLE THERMOMETER TS2-GAR-1 IH87361550

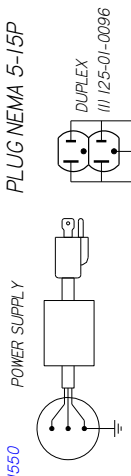

EVAP FANS 125-01-0615A 0.62A @ 120VAC

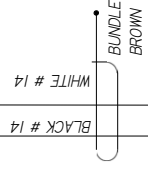

120VAC - 60HZ MCA=0.78 MOP=15.0

REAR COIL

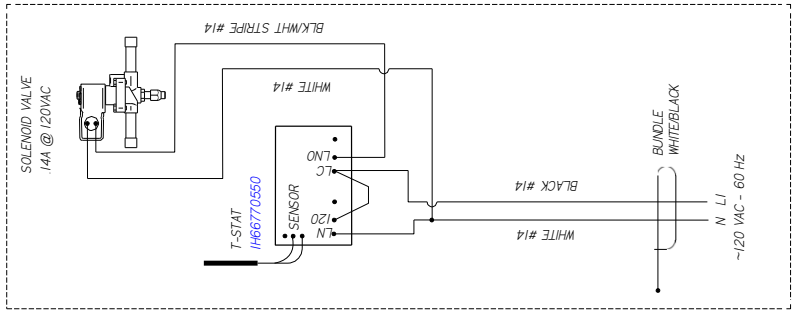

DECK COIL

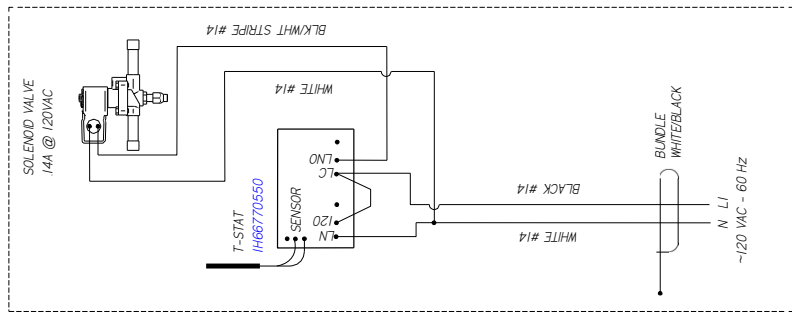

HUMIDITY FAN 125-01-2011-H 1.6A @ 120VAC

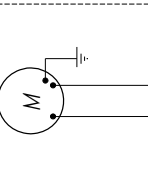

120VAC - 60HZ MCA=0.20 MOP=15.0

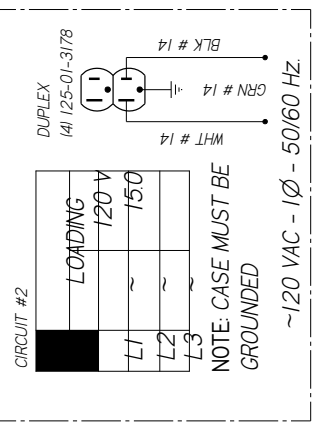

NOTE: CASE MUST BE GROUNDED

~120 VAC - 1Ø - 50/60 HZ.

FLUSH SYSTEM OPTIONAL

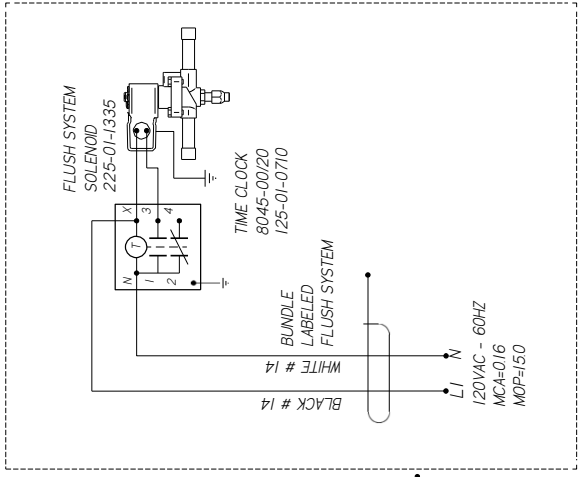

TIME CLOCK 8045-00120 125-01-0710

FLUSH SYSTEM SOLENOID

120VAC - 60HZ MCA=0.16 MOP=15.0

**HUSSMANN**  
DIAGRAM-DSFI-EP-2-R

MATERIAL - N/A  
DATE DRAWN - 5-16-18  
DRAWN BY - CRAIG BOOREY  
REVIEWED BY - CRAIG BOOREY  
APPROVED BY - CRAIG BOOREY  
UNLESS OTHERWISE SPECIFIED DIMENSIONS ARE IN INCHES  
TOLERANCES ARE:  
DECIMALS .XX ±0.3 .XXX ±0.1  
ANGLES ± 2°

EON-CAP-0012694 REF -  
SHEET 1 OF 2  
DIMENSIONS ARE IN INCHES  
THIRD ANGLE PROJECTION

3063099 | B

NOTE: CASE MUST BE GROUNDED WHEN PASSING WIRES THROUGH METAL HOLES A GROMMET MUST BE USED



REVISION HISTORY		REV	BY	DATE	DESCRIPTION	REV	BY	DATE	DESCRIPTION
A	ECN-CAP-0012694	2018/05/16			RELEASED TO PRODUCTION	CB			CB
B	ECN-CAP-0012694	2018/05/24			ADDED DIGITAL T-STATS	CB			CB

CIRCUIT #1	LOADING	120V	150V
L1			
L2			
L3			

NOTE: CASE MUST BE GROUNDED

~120 VAC - 1Ø - 50/60 HZ.

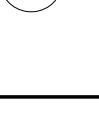
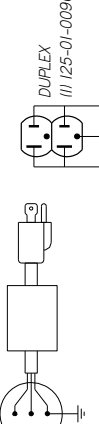
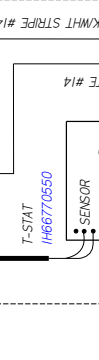
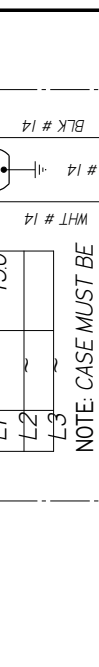
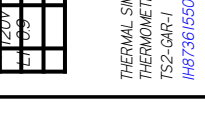
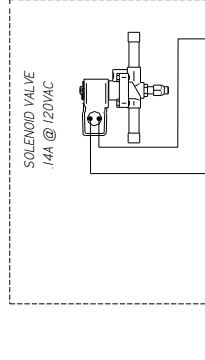
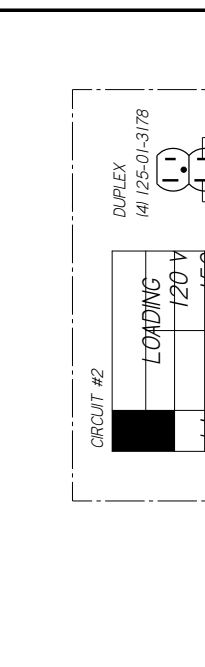
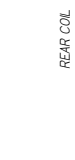
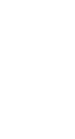

NOTE: CASE MUST BE GROUNDED

~120 VAC - 1Ø - 50/60 HZ.

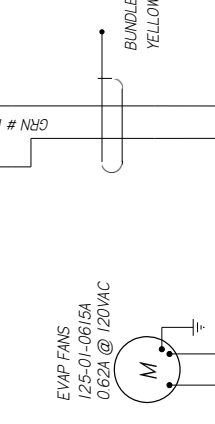
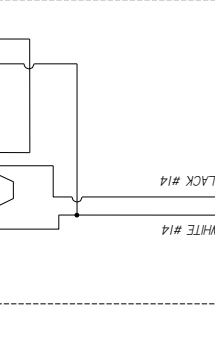
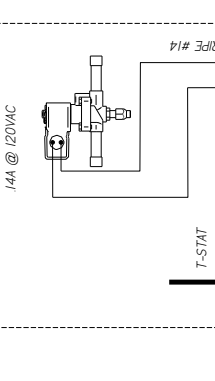
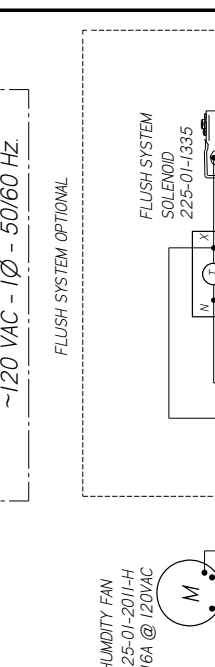
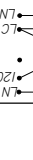

NOTE: CASE MUST BE GROUNDED

~120 VAC - 1Ø - 50/60 HZ.

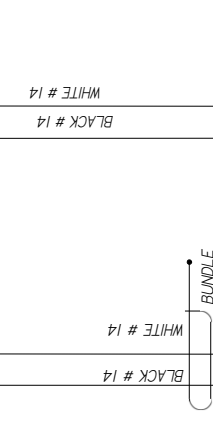
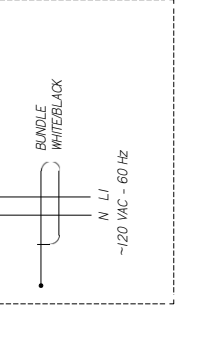
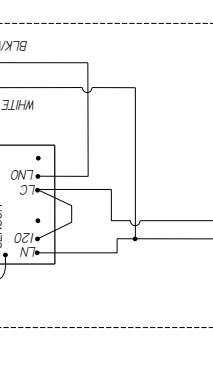
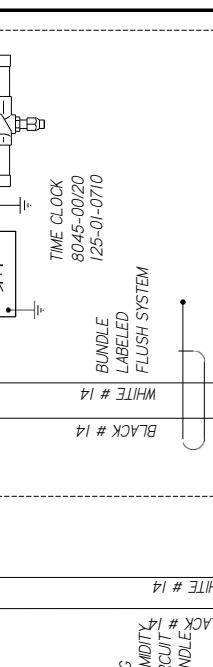
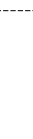

NOTE: CASE MUST BE GROUNDED

~120 VAC - 1Ø - 50/60 HZ.

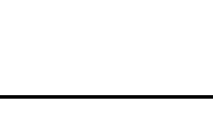
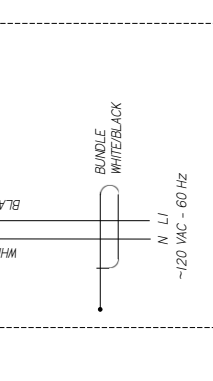
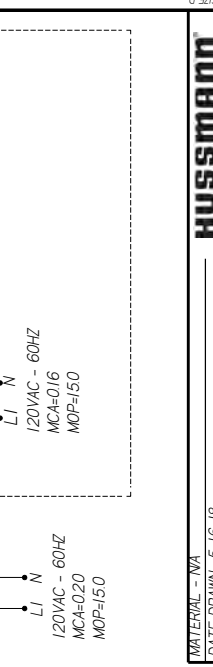
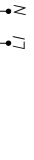

NOTE: CASE MUST BE GROUNDED

~120 VAC - 1Ø - 50/60 HZ.

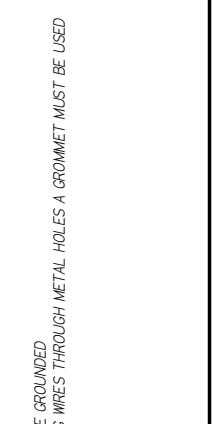
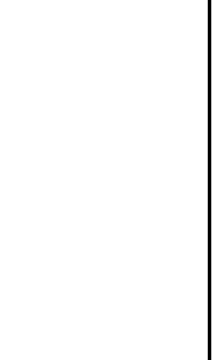
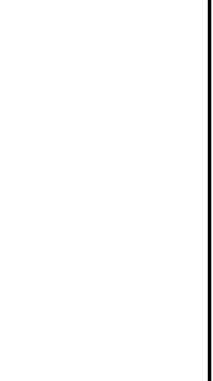
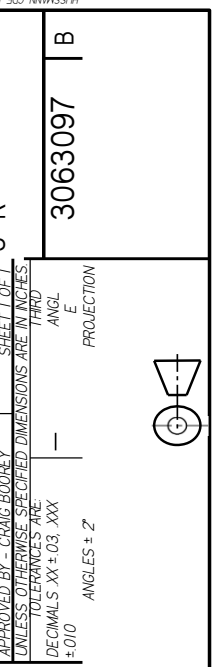

**HUSSMANN**  
DIAGRAM-DSFI-EP-3-R

MATERIAL - N/A  
DATE DRAWN - 5-16-18  
DRAWN BY - CRAIG BOOREY  
REVIEWED BY - CRAIG BOOREY  
APPROVED BY - CRAIG BOOREY  
UNLESS OTHERWISE SPECIFIED DIMENSIONS ARE IN INCHES  
TOLERANCES ARE:  
DECIMALS .XX ±0.3 .XXX  
±0.0 ANGL  
E PROJECTION

3063097 | B



CIRCUIT #1	LOADING	120V	150V

POWER SUPPLY  
THERMAL SIMPLE THERMOMETER  
TS2-GAR-1  
IH87361550

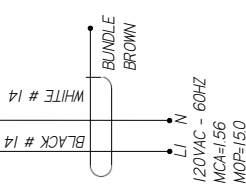
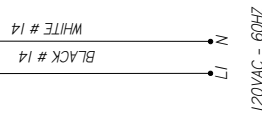
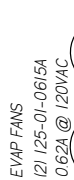
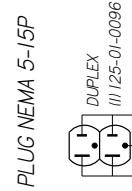
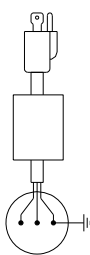

REAR COIL

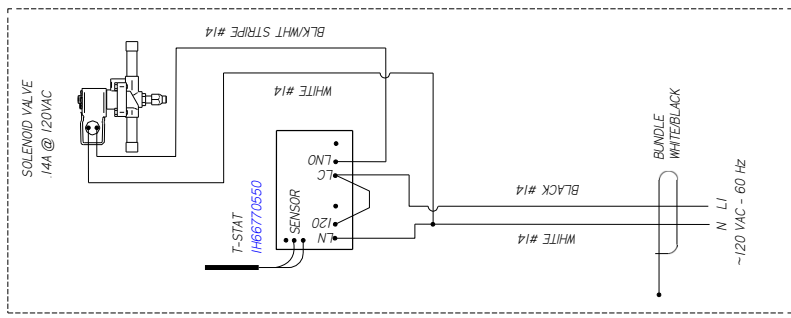

DECK COIL

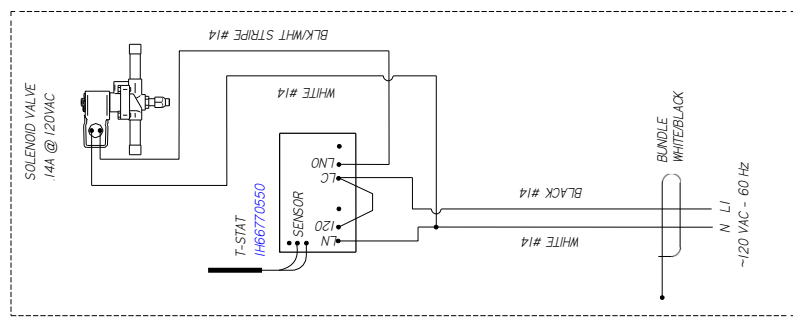

HUMIDITY FAN  
125-01-2011-H  
1.6A @ 120VAC

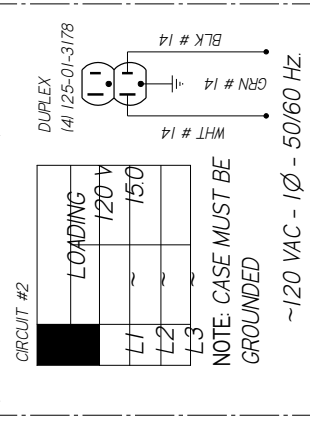
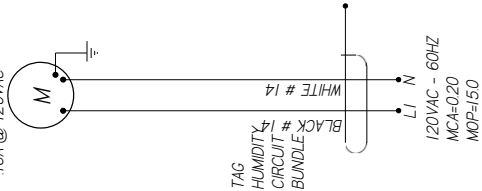

FLUSH SYSTEM OPTIONAL

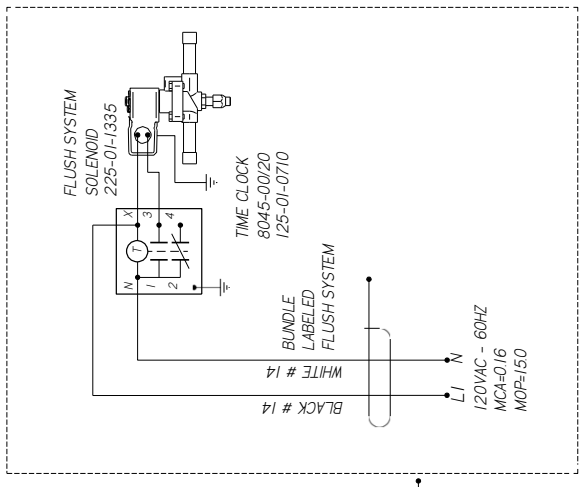

REV	EN	DATE	REVISION DESCRIPTION	REV BY	CHK BY	APP BY
A	ECN-CAP-002694	20080516	RELEASED TO PRODUCTION	CB	CB	CB
B	ECN-CAP-002696	20080524	ADDED DIGITAL T-STATS	CB	CB	CB
C	ECN-CAP-003267	20100625	ADDED A 2ND FAN MOTOR	CB	CB	CB

MATERIAL - N/A  
DATE DRAWN - 5-16-18  
DRAWN BY - CRAIG BOOREY  
REVIEWED BY - CRAIG BOOREY  
APPROVED BY - CRAIG BOOREY  
UNLESS OTHERWISE SPECIFIED DIMENSIONS ARE IN INCHES  
TOLERANCES ARE:  
DECIMALS .XX ±0.3 .XXX  
ANGLES ± 2°  
PROJECTION  
E  
C

**HUSSMANN**  
DIAGRAM-DSFN-EP-5

-R

3063096



NOTES:  
CASE MUST BE GROUNDED  
WHEN PASSING WIRES THROUGH METAL HOLES A GROMMET MUST BE USED

REV	EN	DATE	DESCRIPTION	REV BY	CHKD BY	APPR BY
1	EA	01/29/18	RELEASE TO PRODUCTION	CB	CB	CB

REVISION HISTORY
RELEASE TO PRODUCTION

CIRCUIT #1	LOADING
L1	120V
L2	150
L3	

CIRCUIT #2	LOADING
L1	120V
L2	150
L3	

NOTE: CASE MUST BE GROUNDED

~120 VAC - 1Ø - 50/60 HZ



OPTIONAL

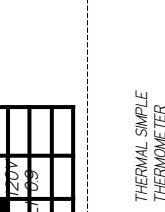
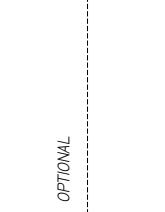
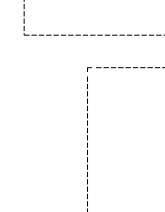
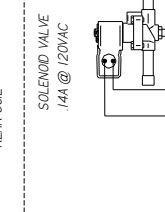
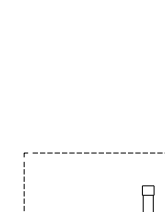
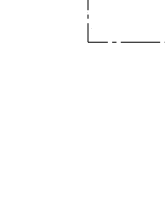
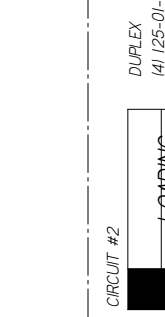

OPTIONAL

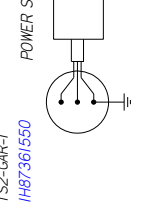
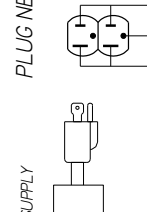
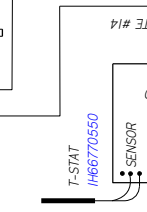
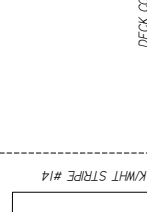

OPTIONAL

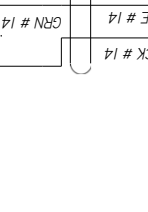
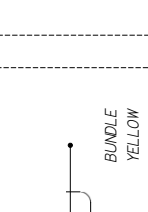
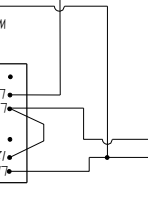
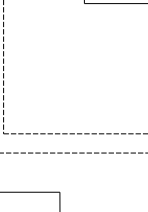
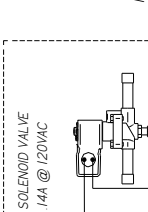
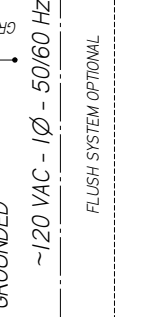

OPTIONAL

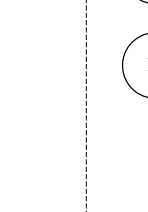
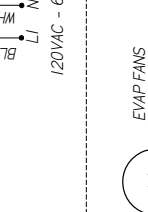
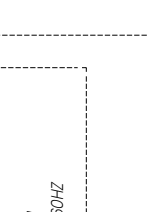
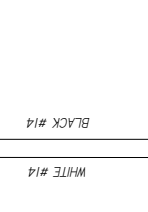
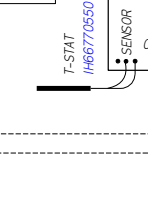
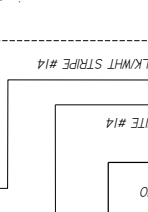
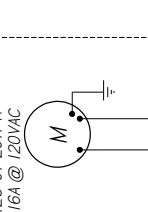
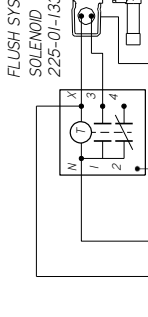

OPTIONAL

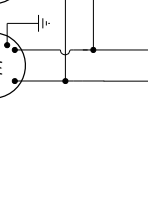
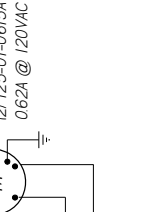
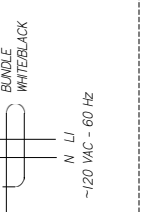
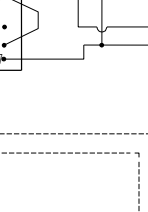
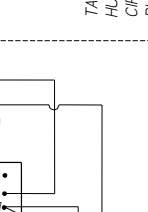
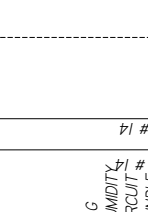
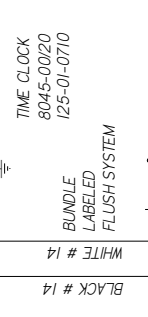

OPTIONAL

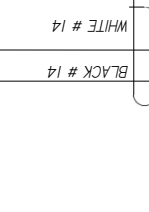
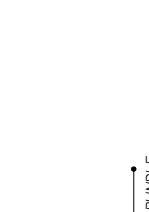
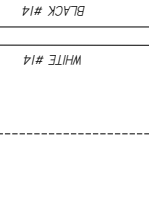
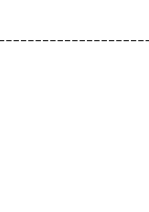
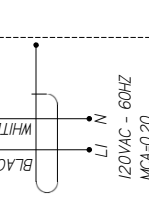

OPTIONAL

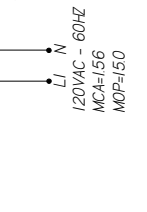
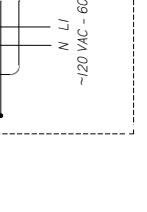
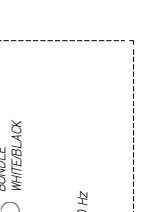
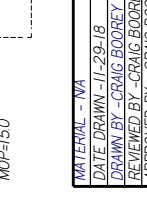
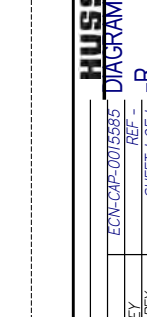

OPTIONAL

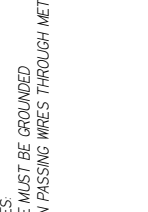
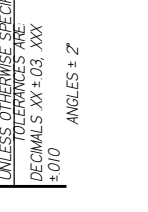

OPTIONAL

**HUSSMANN**  
**DIAGRAM-DSFN-EP-6**

MATERIAL - NA  
DATE DRAWN - 11-29-18  
DRAWN BY - CRAIG BOOREY  
REVIEWED BY - CRAIG BOOREY  
APPROVED BY - CRAIG BOOREY  
UNLESS OTHERWISE SPECIFIED DIMENSIONS ARE IN INCHES  
TOLERANCES ARE:  
DECIMALS .XX ±0.03 .XXX  
±0.0 ANGL  
E  
PROJECTION

REF -  
SHEET 1 OF 1

3081699

ANGLES ± 2°

NOTES:  
CASE MUST BE GROUNDED  
WHEN PASSING WIRES THROUGH METAL HOLES A GROMMET MUST BE USED

EVAP FANS  
121 125-01-0615A  
062A @ 120VAC

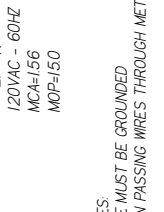

OPTIONAL

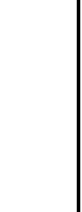
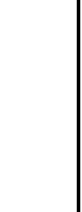
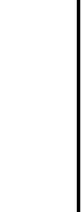
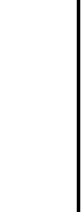

OPTIONAL

CIRCUIT #1	LOADING	120V	L1	L2	L3

REVISION HISTORY		REV. BY	CHKD BY	APPR BY
1	EON-CAP-0013268	2018/09/27	CB	CB
REVISION DESCRIPTION				
RELEASED TO PRODUCTION				

OPTIONAL

THERMAL SIMPLE THERMOMETER TS2-GAR-1 IH87361550

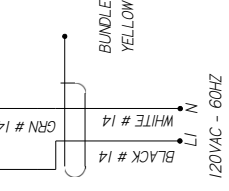
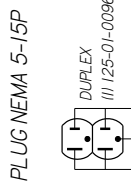
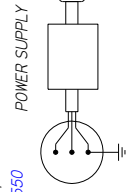

REAR COIL

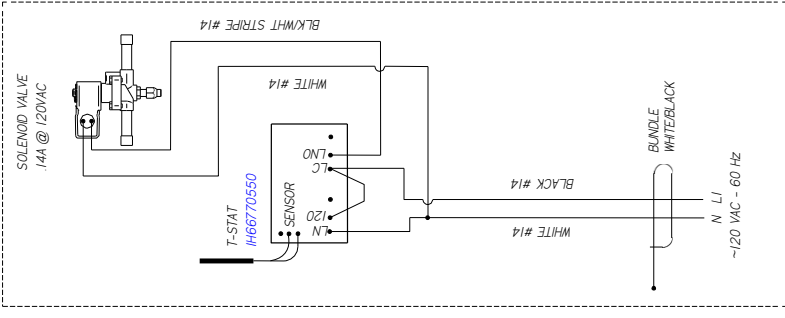

DECK COIL

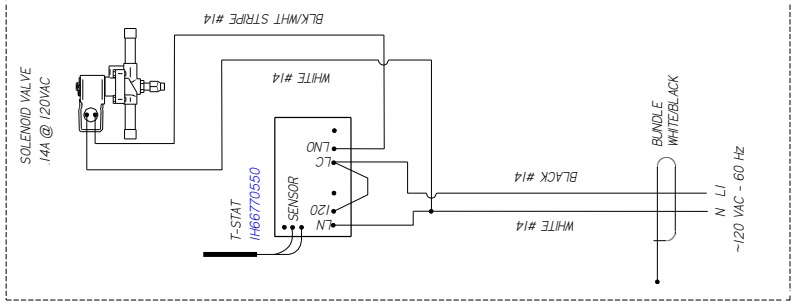

HUMIDITY FAN 125-01-2011-H .16A @ 120VAC

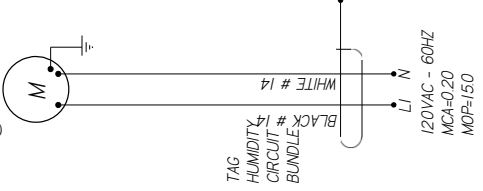

CIRCUIT #2

LOADING	120V	150
L1		
L2		
L3		

NOTE: CASE MUST BE GROUNDED

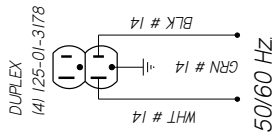

FLUSH SYSTEM OPTIONAL

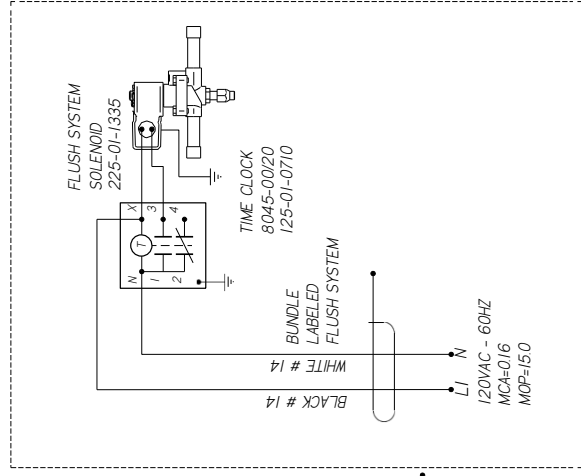

MATERIAL - N/A

DATE DRAWN - 6-27-18

DRAWN BY - CRAIG BOOREY

REVIEWED BY - CRAIG BOOREY

APPROVED BY - CRAIG BOOREY

UNLESS OTHERWISE SPECIFIED DIMENSIONS ARE IN INCHES

TOLERANCES ARE:

DECIMALS .XX ±0.3 .XXX ±0.0

ANGLES ± 2°

HUSSMANN

DIAGRAM-DSFN-EP-8

REF -

SHEET NO.

THIRD

ANGL

E

PROJECTION

3067227

A



NOTES:  
CASE MUST BE GROUNDED  
WHEN PASSING WIRES THROUGH METAL HOLES A GROMMET MUST BE USED

REV	EN	DATE	REVISION DESCRIPTION	REV BY	CHKD BY	APPR BY
1	EA	2018/01/05	RELEASED TO PRODUCTION	CB	CB	CB

CIRCUIT #1	LOADING
L1	120V
L2	150
L3	

NOTE: CASE MUST BE GROUNDED

OPTIONAL

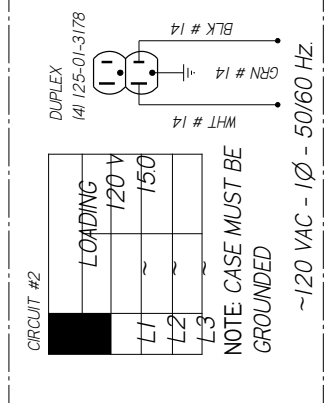
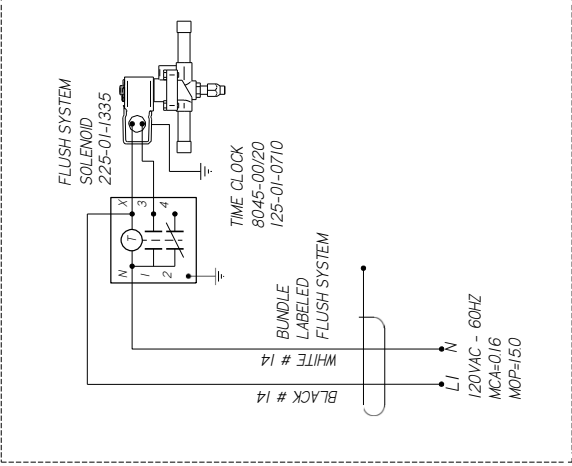
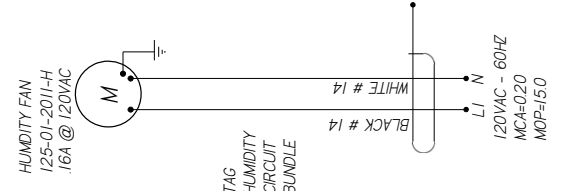
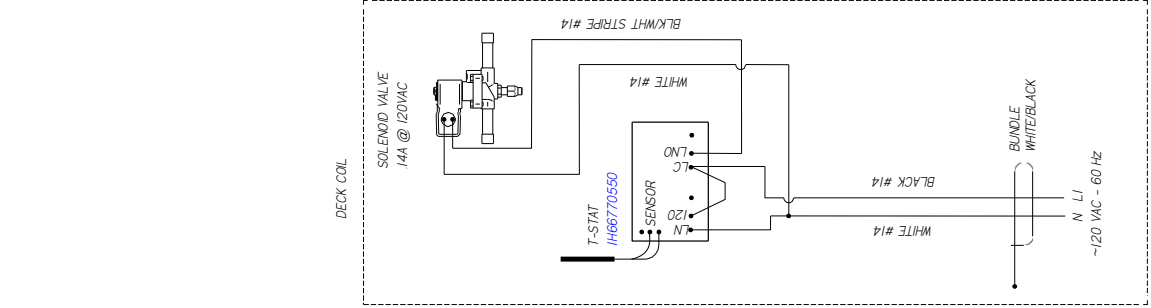
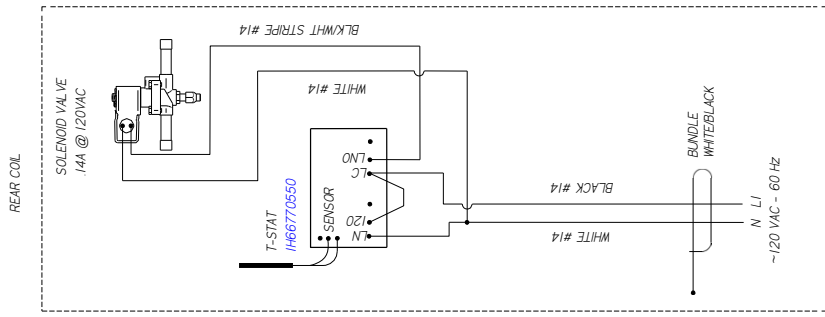
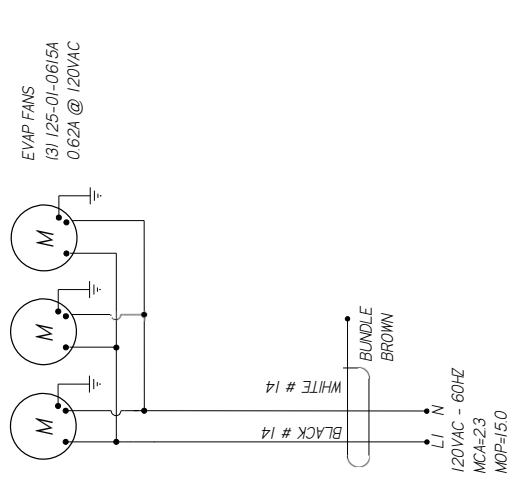
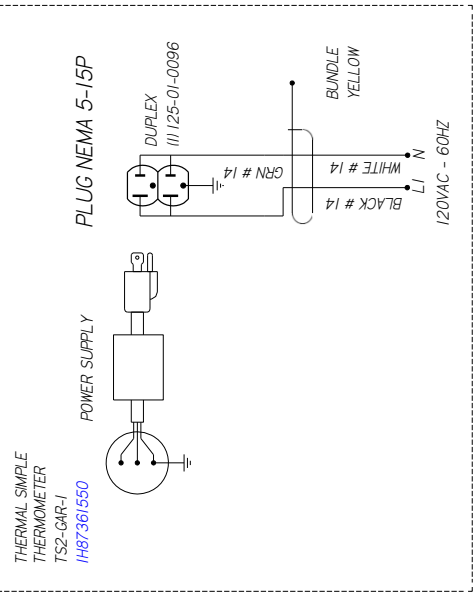

FLUSH SYSTEM OPTIONAL

**HUSSMANN**  
**DIAGRAM=DSFN-EF-**  
**10-R**

MATERIAL - N/A  
DATE DRAWN - 10-15-18  
DRAWN BY - CRAIG ROOREY  
REVIEWED BY - CRAIG ROOREY  
APPROVED BY - CRAIG ROOREY  
UNLESS OTHERWISE SPECIFIED DIMENSIONS ARE IN INCHES  
TOLERANCES ARE:  
DECIMALS .XX ±0.3 .XXX  
ANGLES ±2°

PROJECTION

3077613

A



NOTES:  
CASE MUST BE GROUNDED  
WHEN PASSING WIRES THROUGH METAL HOLES A GROMMET MUST BE USED

REVISION HISTORY		REV	BY	DATE	DESCRIPTION	REV	BY	DATE	DESCRIPTION
A	ECN-CAP-002694	1	2018/05/16	2018/05/16	RELEASED TO PRODUCTION	CB	CB	CB	CB
B	ECN-CAP-002696	2	2018/05/24	2018/05/24	ADDED DIGITAL T-STATS	CB	CB	CB	CB

CIRCUIT #1	LOADING	120V	150V

THERMAL SIMPLE THERMOMETER  
TS2-GAR-1  
IH87361550

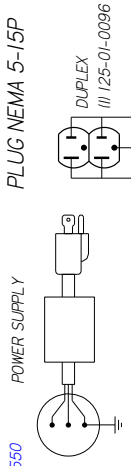

EVAP FANS  
125-01-0615A  
0.62A @ 120VAC

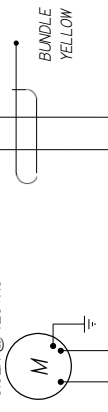

120VAC - 60HZ  
MCA=0.78  
MOP=150

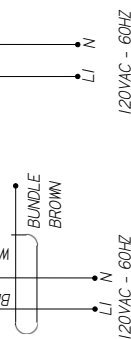

L/R REAR COIL

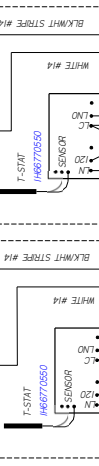
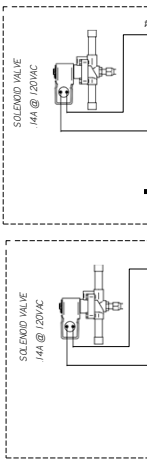

R/H REAR COIL



HUMIDITY FAN  
125-01-2011-H  
16A @ 120VAC

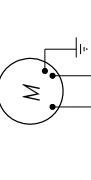

120VAC - 60HZ  
MCA=0.20  
MOP=150

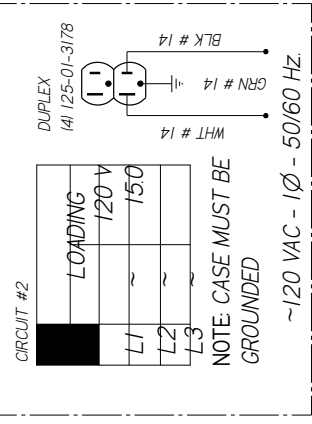
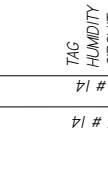

FLUSH SYSTEM OPTIONAL

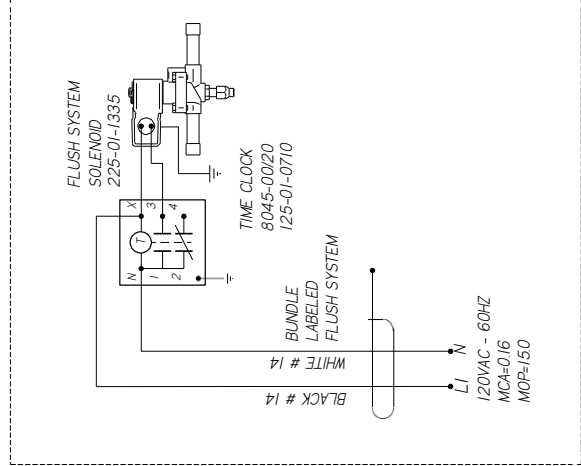

MATERIAL - INVA  
DATE DRAWN - 5-16-18  
DRAWN BY - CRAIG ROOREY  
REVIEWED BY - CRAIG ROOREY  
APPROVED BY - CRAIG ROOREY  
UNLESS OTHERWISE SPECIFIED DIMENSIONS ARE IN INCHES  
TOLERANCES ARE:  
DECIMALS .XX ±0.0, .XXX ±0.0  
ANGLES ± 2°  
PROJECTION

HUSSMANN  
DIAGRAM-DSFI-EP-450-R

3063100 | B



NOTES:  
CASE MUST BE GROUNDED  
WHEN PASSING WIRES THROUGH METAL HOLES A GROMMET MUST BE USED

REVISION HISTORY		REV	ECN	DATE	REVISION DESCRIPTION	REV BY	CHKD BY	APPR BY
A		ECN-COD-0013664		5-24-21	RELEASED TO PRODUCTION	CB	CB	CB

LIGHT CIRCUIT = 0.11A @ 124W

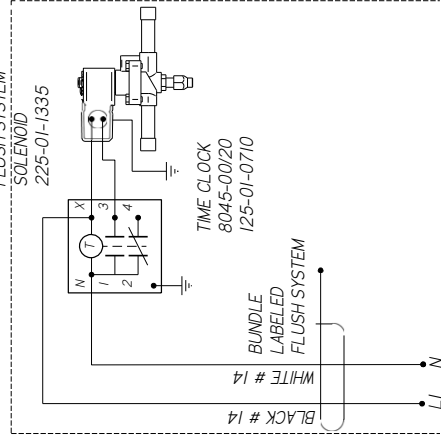
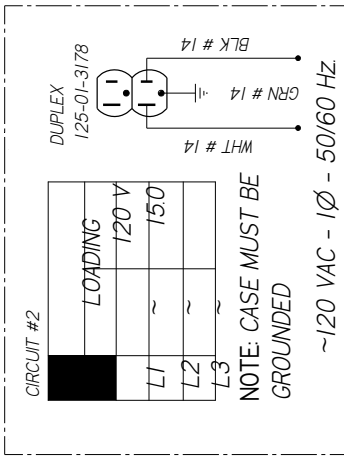
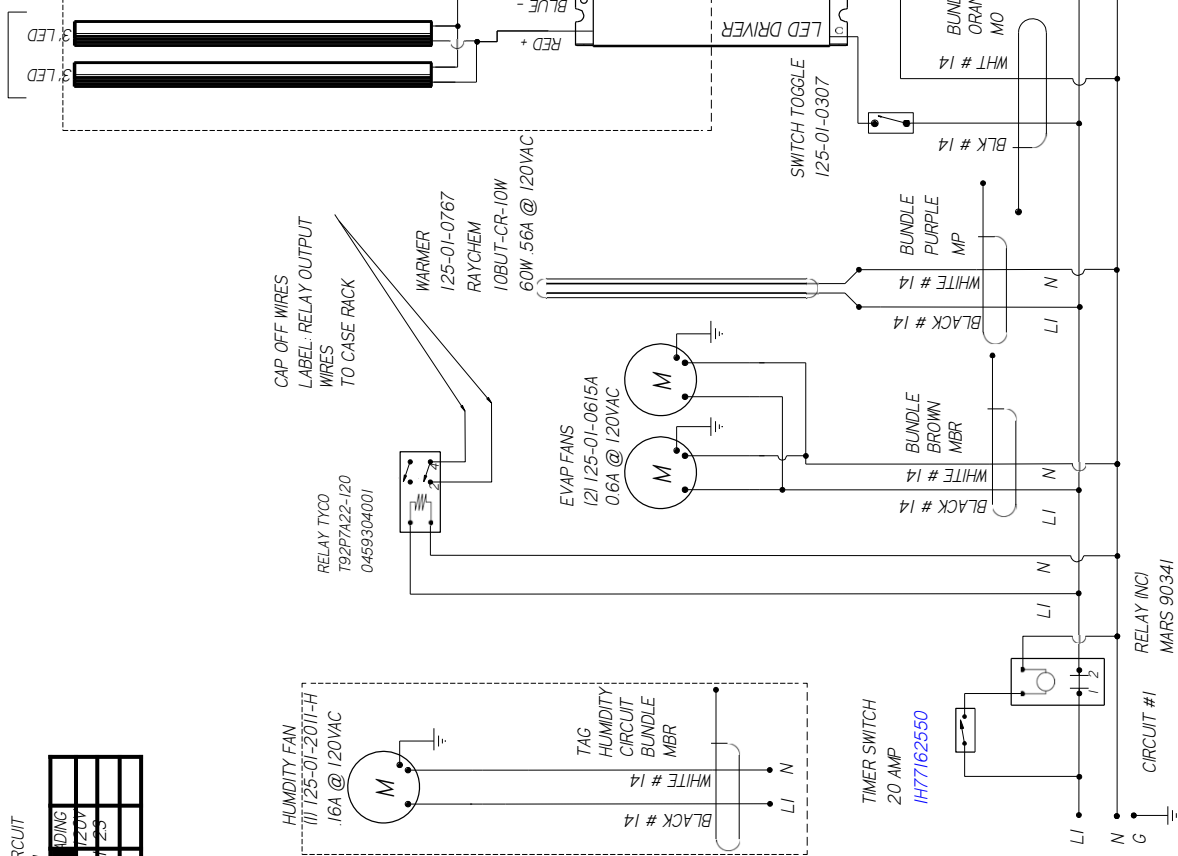

CIRCUIT #	LOADING	REV	DATE	BY
1	120V			
2	150			
3				

**HUSSMANN**

DIAGRAM-DSFNM-EP  
-CNP-6R

FACTORY 14GA WIRE  
-FACTORY 10GA WIRE  
-FIELD WIRE

DO NOT SCALE DRAWING  
SHEET 1 OF 1

3149539

UL COLOR CODES / ABBREVIATIONS

- RED = RD
- BLACK = BK
- BLUE = BL
- YELLOW = YL
- GRAY = GR
- WHITE = WT
- GREEN = GN
- BROWN = BN
- ORANGE = OR
- OR VIOLET = VT

- NOTES:
1. PRINTED DOCUMENT REQUIRED SETTING. ALL COLORS BLACK & WHITE
  2. CASE & ANY REMOVABLE PANEL WITH ELECTRICAL PARTS MUST BE GROUNDED.
  3. WHEN PASSING WIRES THROUGH METAL HOLES A GROMMET MUST BE USED

REVISION HISTORY			
REV	ECN	DATE	REVISION DESCRIPTION
A	ECN-CAP-0020429	12-19-19	RELEASED TO PRODUCTION

CIRCUIT #1	
LOADING	REV BY / CKD BY / APPR BY
120V	CB
150	CB
~	CB
~	CB

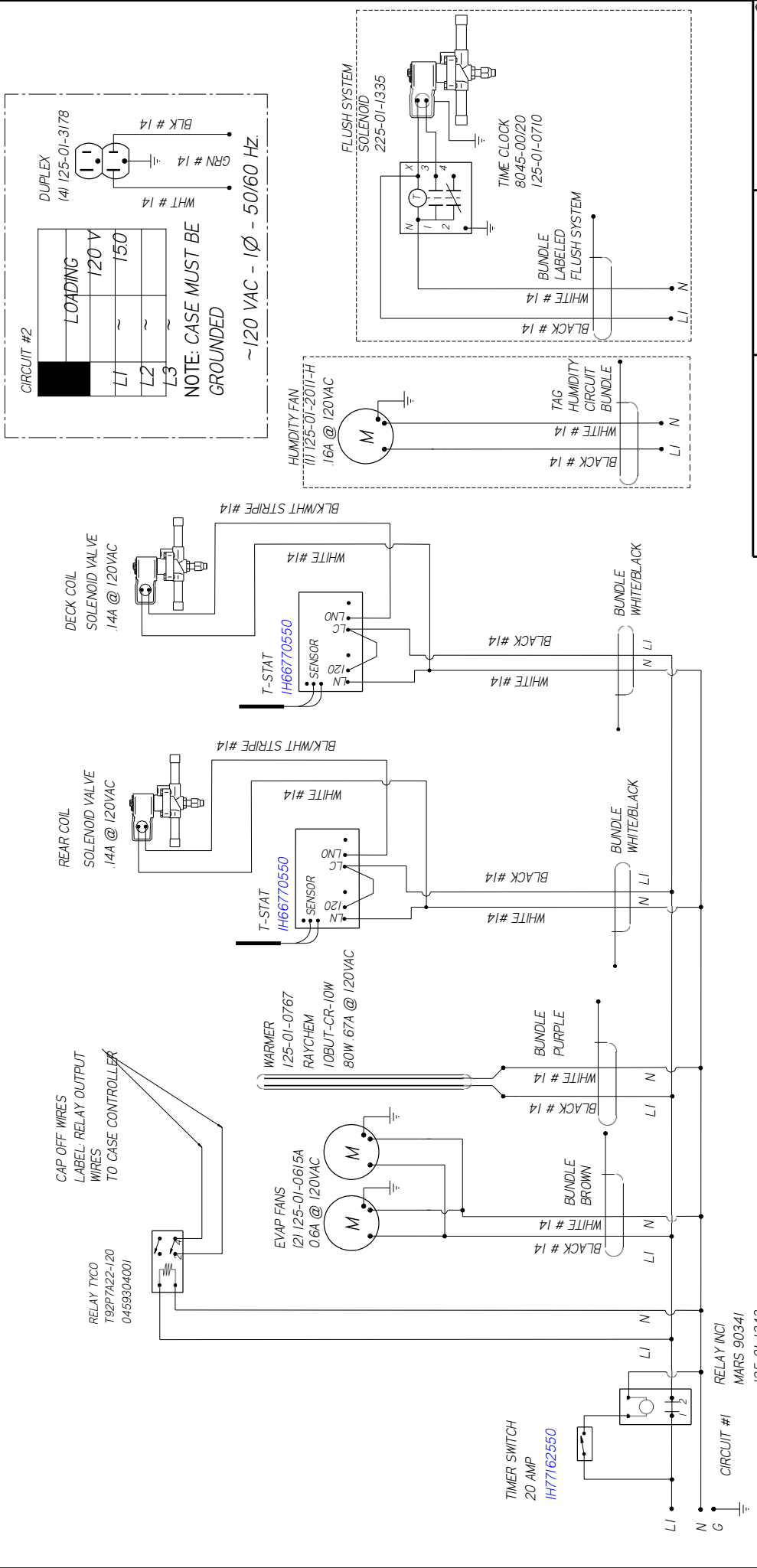

**HUSSMANN**  
**DIAGRAM-DSFM-8-EP**  
**-R**

FACTORY 14GA WIRE  
 -FACTORY 10GA WIRE  
 -FIELD WIRE

DO NOT SCALE DRAWING  
 SHEET 1 OF 1

UL COLOR CODES / ABBREVIATIONS  
 RED = RD  
 BLACK = BK  
 BLUE = BL  
 YELLOW = YL  
 GRAY = GR  
 WHITE = WT  
 GREEN = GN  
 BROWN = BN  
 ORANGE = OR  
 VIOLET = VT

- NOTES:
1. PRINTED DOCUMENT REQUIRED SETTING. ALL COLORS BLACK & WHITE
  2. CASE & ANY REMOVABLE PANEL WITH ELECTRICAL PARTS MUST BE GROUNDED.
  3. WHEN PASSING WIRES THROUGH METAL HOLES A GROMMET MUST BE USED

3114302

A



REVISION HISTORY		REV	ECN	DATE	REVISION DESCRIPTION	REV BY	CHKD BY	APPR BY
A	ECN-COD-0013664	5-24-21	RELEASED TO PRODUCTION	CB	CB	CB	CB	CB

CIRCUIT #	LOADING	120V	150V
#1			
#2			
#3			

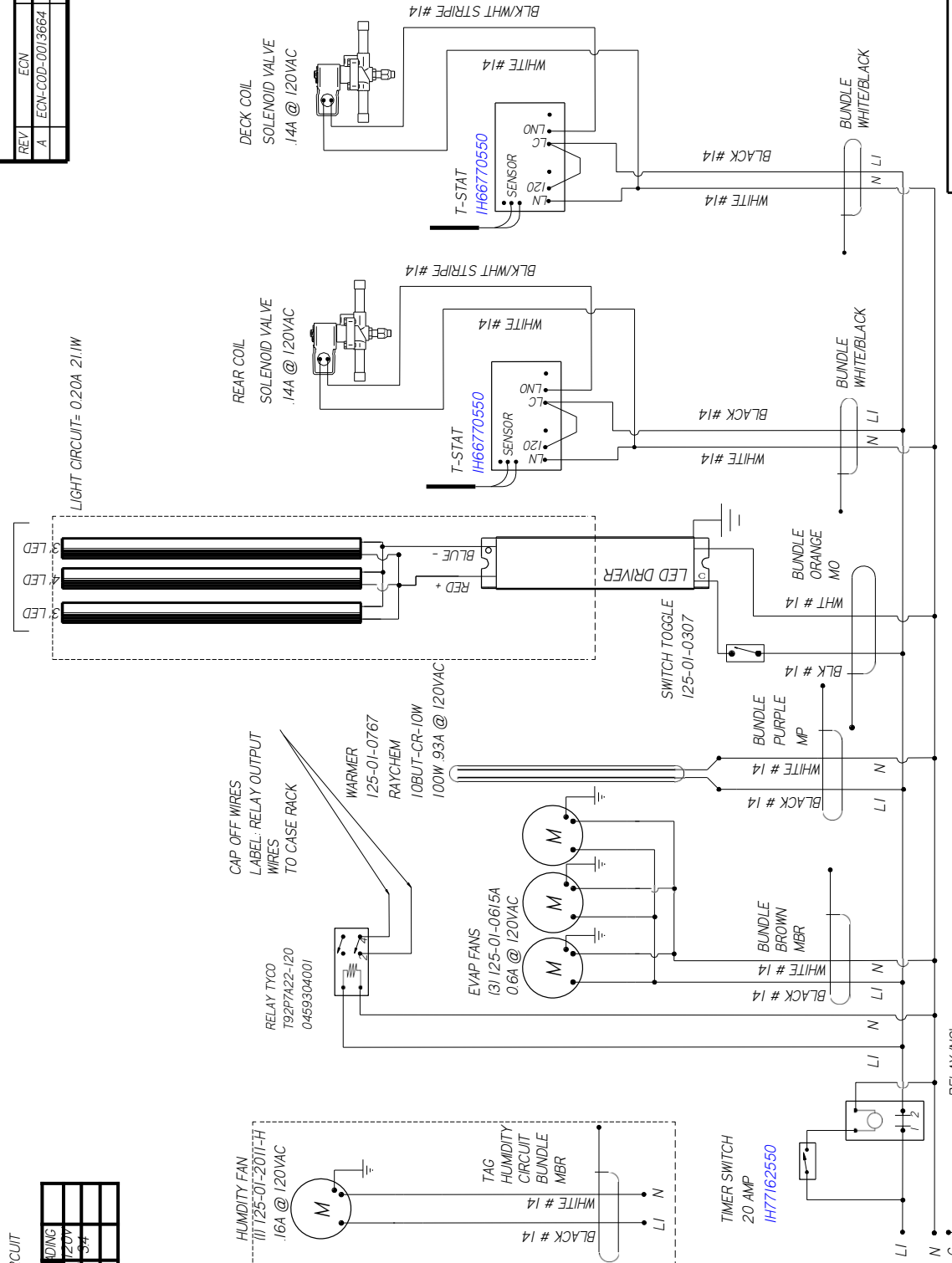

LIGHT CIRCUIT = 0.20A 21.1W

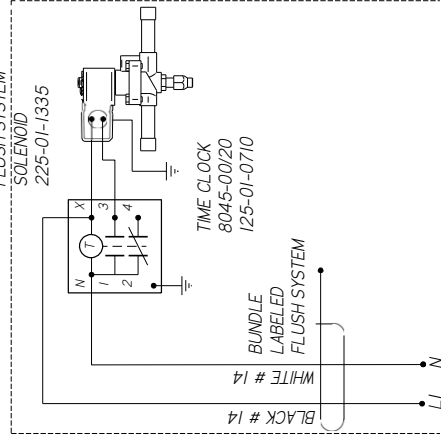
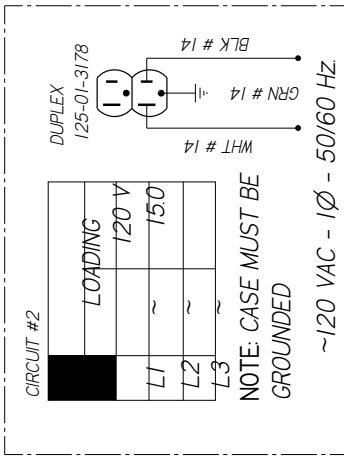

**HUSSMANN**

DIAGRAM-DSFNW-EP -CNP-10-R

FACTORY 14GA WIRE  
 -FACTORY 10GA WIRE  
 -FIELD WIRE  
 -DO NOT SCALE DRAWING  
 SHEET 1 OF 1

UL COLOR CODES / ABBREVIATIONS

- RED = RD
- BLACK = BK
- BLUE = BL
- YELLOW = YL
- GRAY = GR
- WHITE = WT
- GREEN = GN
- BROWN = BN
- ORANGE = OR
- VIOLET = VT

3149540

- NOTES:
1. PRINTED DOCUMENT REQUIRED SETTING. ALL COLORS BLACK & WHITE
  2. CASE & ANY REMOVABLE PANEL WITH ELECTRICAL PARTS MUST BE GROUNDED.
  3. WHEN PASSING WIRES THROUGH METAL HOLES A GROMMET MUST BE USED

CIRCUIT #	14	120V	
REV	A		
ECN			
DATE			
REVISION DESCRIPTION			
REV BY/CHKD BY			
APPR BY			

REV	ECN	DATE	REVISION DESCRIPTION	REV BY/CHKD BY	APPR BY
A	ECN-COD-0013664	5-24-21	RELEASED TO PRODUCTION	CB	CB

REVISION HISTORY	
------------------	--

LIGHT CIRCUIT= 0.05A 58W

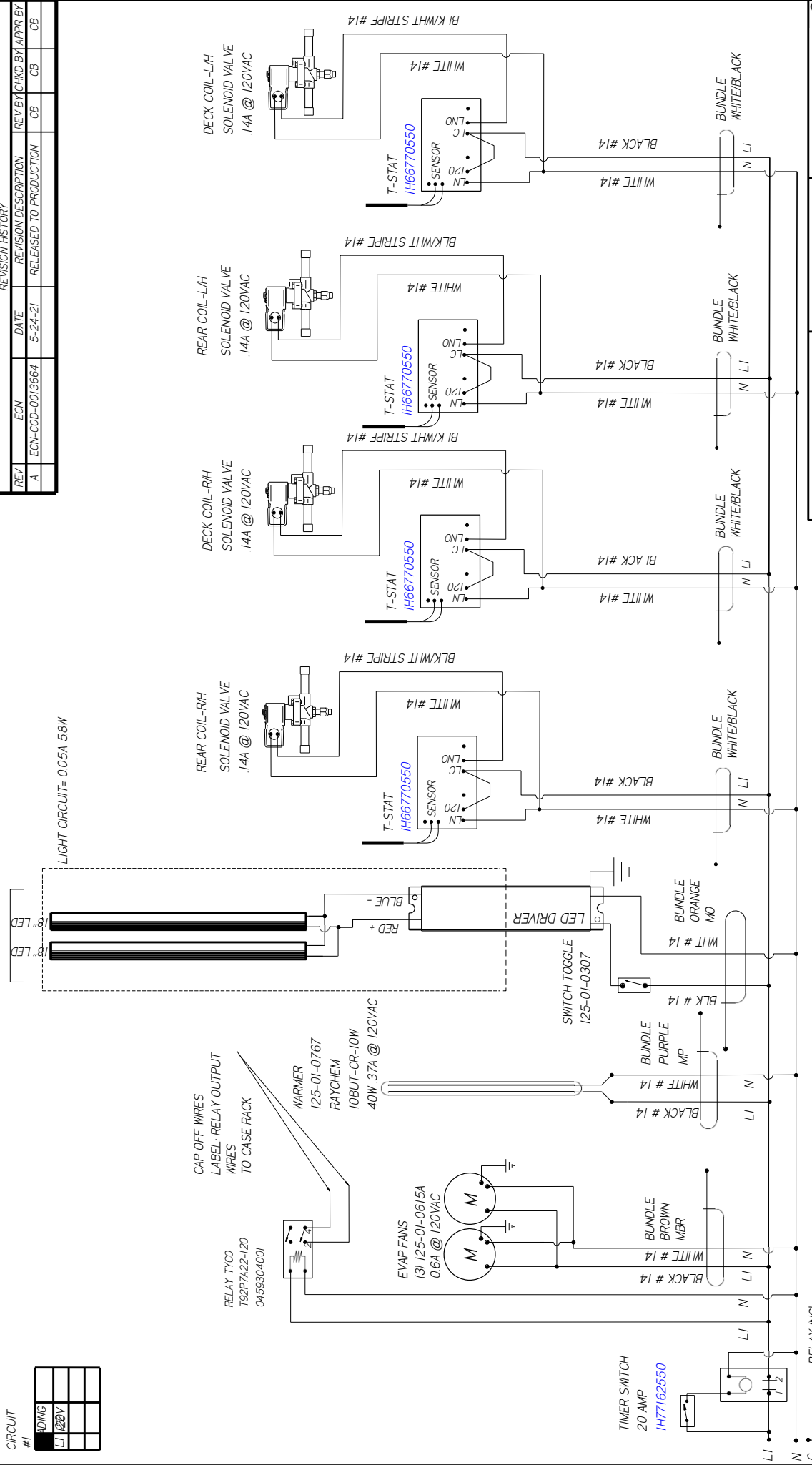

**HUSSMANN**  
**DIAGRAM-DSFNM-EP**  
**-CNP-450-R**

FACTORY 14GA WIRE  
 FACTORY 10GA WIRE  
 FIELD WIRE  
 DO NOT SCALE DRAWING  
 SHEET 1 OF 2

UL COLOR CODES / ABBREVIATIONS  
 RED = RD  
 BLACK = BK  
 BLUE = BL  
 YELLOW = YL  
 GRAY = GR  
 WHITE = WT  
 GREEN = GN  
 BROWN = BN  
 ORANGE = OR  
 VIOLET = VT

- RELAY INCI  
 MARS 90341  
 CIRCUIT # 125-01-1343
- NOTES:  
 1. PRINTED DOCUMENT REQUIRED SETTING. ALL COLORS BLACK & WHITE  
 2. CASE & ANY REMOVABLE PANEL WITH ELECTRICAL PARTS MUST BE GROUNDED.  
 3. WHEN PASSING WIRES THROUGH METAL HOLES A GROMMET MUST BE USED

3149541  
 A

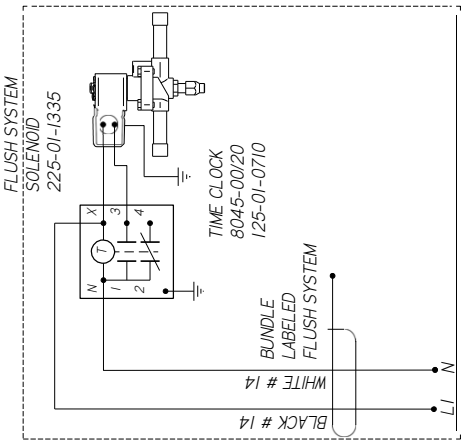
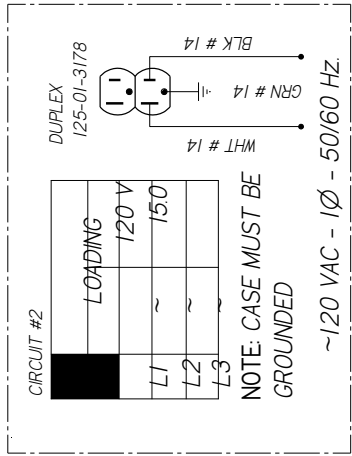
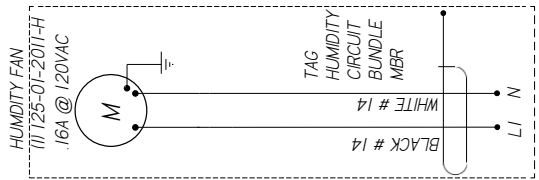

- NOTES:
1. PRINTED DOCUMENT REQUIRED SETTING: ALL COLORS BLACK & WHITE
  2. CASE & ANY REMOVABLE PANEL WITH ELECTRICAL PARTS MUST BE GROUNDED.
  3. WHEN PASSING WIRES THROUGH METAL HOLES A GROMMET MUST BE USED

**HUSSMANN**  
 DIAGRAM-DSFNM-EP  
 -CNP-450-R

FACTORY 14GA WIRE  
 \_FACTORY 10GA WIRE  
 \_ \_ \_ \_ \_FIELD WIRE  
 \_ \_ \_ \_ \_DO NOT SCALE DRAWING  
 SHEET 2 OF 2

UL COLOR CODES / ABBREVIATIONS  
 RED = RD    WHITE = WT  
 BLACK = BK    GREEN = GN  
 BLUE = BL    BROWN = BN  
 YELLOW =    ORANGE =  
 YL GRAY =    OR VIOLET =  
 GY                    VT

3149541 | A

## Maintenance

### Case Cleaning

To insure long life, proper sanitation and minimum maintenance costs, the refrigerator should be thoroughly cleaned frequently. **SHUT OFF FAN BEFORE CLEANING:** It can be unplugged within the case, or shut off entire case at the source. The interior bottom may be wiped with any domestic soap or detergent based cleaners. Sanitizing solutions will not harm the interior bottom,

**WARNING! DO NOT USE WATER HOSES!** A self contained case empties into an evaporator pan that **WILL OVERFLOW IF TOO MUCH WATER IS INTRODUCED** during cleaning

- USE WATER AND A MILD DETERGENT FOR THE EXTERIOR ONLY
- Wipe interior with damp non-abrasive cloth. Soap and hot water are not enough to kill bacteria; a sanitizing solution must be included with each cleaning process to eliminate bacteria.
- Clean any visible debris surrounding or on top of the drain location. The drain is located under the deck pans.
- DO NOT USE A CHLORINATED CLEANER ON ANY SURFACE.
- DO NOT USE ABRASIVES OR STEEL WOOL SCOURING PADS (these will mar the finish)

- DO NOT USE A CLEANING OR SANITIZING SOLUTION THAT HAS AN OIL BASE (these will dissolve the butyl sealants) or an AMMONIA BASE (this will corrode the copper components of the case)

### Service

- To maintain good refrigeration performance, a refrigeration service person should be called periodically (at least twice a year) to clean the discharge honeycomb and remove any accumulated dirt from the condenser coil and condensate evaporator pan on self-contained models. **POOR CIRCULATION OF AIR THROUGH THE CONDENSER COIL WILL RESULT IN POOR REFRIGERATION PERFORMANCE.**
- Dirt accumulation inside the condensate evaporator pan will reduce the pan's capacity and affect the efficiency of the heater causing a burned out heater and an overflow of defrost water onto the store floor.

### Tips and Troubleshooting

Before calling for service:

- Check power. Ensure reliable electrical power supply to the equipment
- Check shelf loading. Overstocking will adversely affect case performance.
- If frost is collecting on fixture or product, verify that store Humidity Control is working properly, and that no outside doors/windows allow moisture into store.

## Service Tips

### WARNING

**ALWAYS DISCONNECT THE ELECTRICAL POWER AT THE MAIN DISCONNECT WHEN SERVICING OR REPLACING ANY ELECTRICAL COMPONENT OF THIS REFRIGERATOR. THIS INCLUDES, BUT IS NOT LIMITED TO SUCH ITEMS AS FANS AND THERMOSTATS.**

### Fan Blade Replacement

The evaporator fan is located directly under the deck pan. Should the fan blade ever need servicing. **ALWAYS REPLACE THE FAN BLADE WITH THE RAISED EMBOSSED SIDE OF THE BLADE INSTALLED TOWARD THE MOTOR.**

### Honeycomb Removal & Cleaning

**CAUTION: DO NOT TEAR THE HONEYCOMB**

#### 1) Remove the honeycomb assembly as follows:

Insert a small Phillips screwdriver behind the rear edge of the honeycomb on the right hand end and gently pull down. The bottom of the honeycomb will drop down. Continue down the length of the case, lifting the honeycomb out.

#### 2) To clean honeycomb:

Mix powdered detergent, in warm water. (5 to 7 Tablespoons per gallon)

Immerse or spot clean the honeycomb. Use care not to damage the cell structure of the honeycomb.

Rinse thoroughly in clean water. Shake excess water from the honeycomb and dry. (if heat is used, do not exceed 140 F dry heat)

3) **Install honeycomb** by inserting the notched side up against the deflector and press upwards inserting the bottom of the honeycomb into the back ledge. Slide along the honeycomb, pressing the front edge upward into the ledge. Be careful no to damage the cells or cut yourself on the edges of the honeycomb.

### Ballast Replacement

The power supply for the LED fixtures is located under the case in a dedicated electrical box.

#### For access to the ballast:

- Remove body panels ( See Body panel Removal for reference pg.23)
- Remove screws to grille to expose electrical conduit?
- Replace or service the ballast as required and replace the canopy in reverse order of removal.

## User Information

### Stocking

Improper temperature and lighting will cause serious product loss. Discoloration, dehydration and spoilage can be controlled with proper use of the equipment and handling of product. Product temperature should always be maintained at a constant and proper temperature. This means that from the time the product is received, through storage, preparation and display, the temperature of the product must be controlled to maximize life of the product. Hussmann cases were not designed to “heat up” or “cool down” product - but rather to maintain an item’s proper temperature for maximum shelf life. To achieve the protection required always:

1. Minimize processing time to avoid damaging temperature rise to the product. Product should be at proper temperature.
2. Keep the air in and around the case area free of foreign gasses and fumes or food will rapidly deteriorate.
3. Maintain the display merchandisers temperature controls as outlined in the refrigerator section of this manual.
4. Do not place any product into these refrigerators until all controls have been adjusted and they are operating at the proper temperature. Allow merchandiser to operate a minimum of three (3) hours before stocking with any product.
5. When stocking, never allow the product to extend beyond the recommended load limit. Air discharge and return air flue must be unobstructed at all times to provide proper refrigeration.
6. Avoid the use of supplemental flood or spot lighting. Display light intensity has been designed for maximum visibility and product life at the factory.

### Case Cleaning

Long life and satisfactory performance of any equipment are dependent upon the care given to it. To insure long life, proper sanitation and minimum maintenance costs, the refrigerator should be thoroughly cleaned frequently. SHUT OFF FAN DURING CLEANING PROCESS. It can be unplugged within the case, or shut off entire case at the source. The interior bottom may be cleaned with any domestic soap or detergent based cleaners. Sanitizing solutions will not harm the interior bottom, however, these solutions should always be used according to the Hussmann’s directions. It is essential to establish and regulate cleaning procedures. This will minimize bacteria causing discoloration which leads to degraded product appearance and significantly shortening product shelf life.

Soap and hot water are not enough to kill this bacteria. A sanitizing solution must be included with each cleaning process to eliminate this bacteria.

1. Scrub thoroughly, cleaning all surfaces, with soap and hot water.
2. Rinse with hot water, but do not flood.
3. Apply the sanitizing solution according to Hussmann’s directions.
4. Rinse thoroughly.
5. Dry completely before resuming operation.

### Non-Glare Glass

The high optical clarity of this glass is possible due to special coatings on the glass surface itself. To preserve this coating and the optical clarity, keep the glass clean.

Water is the only solution recommended to be used to clean the non-glare glass. The damage to the glass from improper, caustic solutions is irreparable.

In addition to cleaning the glass with the recommended product, there are precautions that should be taken when working and cleaning the inside of the case.

- When cleaning the inside of the cases, we recommend that the glass be fully opened and covered to prevent solutions from splashing onto the glass and ruining the coating on the inside.

### Plexiglass and Acrylic Care

Improper cleaning not only accelerates the cleaning cycle but also degrades the quality of this surface. Normal daily buffing motions can generate static cling attracting dust to the surface. Incorrect cleaning agents or cleaning cloths can cause micro scratching of the surface, causing the plastic to haze over time.

### Cleaning

Hussmann recommends using a clean damp chamois, or a paper towel marked as “dust and abrasive free” with 210® Plastic Cleaner and Polish available by calling Sumner Labs at 1-800-542-8656. Hard, rough cloths or paper towels will scratch the acrylic and should not be used.



---

This warning does not mean that Hussmann products will cause cancer or reproductive harm, or is in violation of any product-safety standards or requirements. As clarified by the California State government, Proposition 65 can be considered more of a ‘right to know’ law than a pure product safety law. When used as designed, Hussmann believes that our products are not harmful. We provide the Proposition 65 warning to stay in compliance with California State law. It is your responsibility to provide accurate Proposition 65 warning labels to your customers when necessary. For more information on Proposition 65, please visit the California State government website.

---

### Service Record

Last service date:      By:

_____	_____
_____	_____
_____	_____
_____	_____
_____	_____
_____	_____
_____	_____

---

## HUSSMANN®/Chino

Additional copies of this publication may be obtained by contacting:

Hussmann® Chino  
13770 Ramona Avenue • Chino, California 91710  
(909) 628-8942 FAX  
(909) 590-4910  
(800) 395-9229

[www.hussmann.com](http://www.hussmann.com)

The *MODEL NAME* and *SERIAL NUMBER* is required in order to provide you with the correct parts and information for your particular unit.

They can be found on a small metal plate on the unit. Please note them below for future reference.

**MODEL:**

**SERIAL NUMBER:**