

HUSSMANN®

Elite



Service Merchandisers

**Fresh Meat, Delicatessen, and Seafood Merchandisers
(Includes Wedge Installation)
NSF® Certified**



***Installation &
Operation Manual***
Shipped With Case Data Sheets

IMPORTANT
Keep in store for
future reference!

MANUAL- I/O SERVICE ELITE

P/N 0453549_M
Elite Series
August 2018

Spanish 0486359
French 0521927

CONTENTS

INSTALLATION

NSF Certification	1-1
Location	1-1
Shipping Damage	1-1
Exterior Loading	1-2
Merchandisers Shipped with End Installed	1-2
Shipping Braces	1-2
Shipping Rider	1-2
Case Leveling	1-3
Front Glass Positioning	1-4
Joining Instructions	1-8
Installing Bumpers	1-10
Installing Partitions	1-11

REFRIGERATION / ELECTRICAL

Refrigerant	2-1
Refrigerant Piping	2-1
Insulation	2-2
Suction Line	2-2
Liquid Line	2-2
Control Settings	2-2
Refrigeration Thermostat	2-3
Defrost Termination Thermostat	2-3
Merchandiser Electrical Data	2-4
Electrical Connections	2-4
Field Wiring	2-4
Identification of Wiring	2-4

DRIP PIPING AND SPLASHGUARDS

Waste Outlet and Water Seal	3-1
Installing Drip Piping	3-1
Installing Lower Front Panels	3-2
Installing Bottom Rear Panel	3-3

START UP / OPERATION

Start Up	4-1
Load Limits	4-1
Load Limit Profiles	4-1
Stocking	4-2
Installing Shelves	4-2
Multi-Deck Shelf Alignment	4-3
Shelf Maximum Weight Limits	4-3
LED Light Fixtures	4-4
Fluorescent Fixtures	4-5
Procedure for Installing Lighted Shelves. . . .	4-5
Installing FDA/NSF Required Thermometer	4-6

MAINTENANCE

Care and Cleaning	5-1
Interior Cleaning Steps	5-2
Cleaning Coils	5-5
Maintaining Fluorescent Lamps	5-7

SERVICE

Replacing Fan Motors and Blades	6-1
Replacing Ambient Fan and Ambient Heater	6-2
Removing Rail Lamp Cover	6-3
Electrical Service Receptacles	6-3
Replacing Fluorescent Lamps	6-3
Replacing Lamp Holders and End Caps . . .	6-4
Replacing Electronic Ballast	6-4
Replacing LEDs	6-5
Replacing Power Supply(s)	6-6
Replacing Cylinders — Single Pane Glass	6-7
Replacing Glass Hand Grip	6-8
Replacing Front Glass	6-8
Replacing Damaged Drain Fitting	6-9
Repairing Aluminum Coils	6-10

WARRANTY

IMPORTANT
KEEP IN STORE FOR FUTURE REFERENCE
Quality that sets industry standards!

12999 St. Charles Rock Road • Bridgeton, MO 63044-2483

U.S. & Canada 1-800-922-1919 • Mexico 1-800-890-2900

www.hussmann.com

© 2018 Hussmann Corporation

ANSI Z535.5 DEFINITIONS

! • DANGER – Indicate[s] a hazardous situation which, if not avoided, will result in death or serious injury.

! • WARNING – Indicate[s] a hazardous situation which, if not avoided, could result in death or serious injury.

! • CAUTION – Indicate[s] a hazardous situation which, if not avoided, could result in minor or moderate injury.

• NOTICE – Not related to personal injury – Indicates[s] situations, which if not avoided, could result in damage to equipment.

REVISION HISTORY

REVISION M — AUGUST 2018

- 1. Proposition 65 Warning - supercedes prior Proposition 65 Warning

REVISION L — OCTOBER 2015

- 1. Loctite for set screws; 6-9

REVISION K — NOVEMBER 2014

- 1. Proposition 65 Warning Page 1-1
2. no sealer on Drain Fitting, Page 6-7, note on 3-2

REVISION H — JULY 2013

- 1. Added photo Page 1-7; removed all Allen bolt references
2. Added Page 6-5 and 6-6, LED replacement; Power Supply Replacement

REVISION G — APRIL 2013

- 1. Revised Horizontal and Vertical Glass Adjustment, page 1-5 to 1-7
2. Added Warning statement “flammable materials”, Page 1-2 and Page 4-2

REVISION F — NOVEMBER 2012

- 1. Added Installing Shelves, page 4-2
2. LED Light Fixtures, page 4-4
3. Added cleaning coils, page 5-5

REVISION E — DECEMBER 2011

- 1. New Ambient Heater Drawings, page 6-2

REVISION D — APRIL 2011

- 1. Added boxed note, page 4-1

REVISION C — AUGUST 2010

- 1. Added shelf weight limits table, page 4-1
2. Added wedge joining notice, page 1-6

REVISION B — FEBRUARY 2010

- 1. Updated electrical information, page 2-4
2. Revised drip piping pitch, page 3-1
3. Updated fluorescent lamp disposal, page 6-3
4. Added back page

REVISION A

- 1. Added Optional Wrapping Board, page 1-9
2. Added Optional Scale Stand, page 1-11
3. Added NSF Thermometer, pages 4-4, 4-5
4. Updated acceptable water temperature, pages 5-1 and 5-5
5. Added information on cleaning anti-reflective glass, page 5-6
6. Updated WARNING, CAUTION, and NOTICE boxes throughout
7. Added Call Center telephone numbers to bottom of each page

INSTALLATION

NSF LISTING

These merchandisers are manufactured to meet ANSI / UL 471 standard requirements for safety. Proper installation is required to maintain this listing. Near the serial plate, each case carries a label identifying the type of conditions for which the merchandiser was tested.

ANSI/NSF-7 Type I – Display Refrigerator / Freezer Intended for 75°F / 55%RH Ambient Application

ANSI/NSF-7 Type II – Display Refrigerator / Freezer Intended for 80°F / 55%RH Ambient Application

ANSI/NSF-7 – Display Refrigerator Intended for Bulk Produce

FEDERAL / STATE REGULATION

These merchandisers, at the time they are manufactured, meet all federal and state / provincial regulations.

LOCATION

These merchandisers are designed for displaying products in air conditioned stores where temperature is maintained at or below the ANSI/NSF-7 specified level and relative humidity is maintained at or below 55%. Placing refrigerated merchandisers in direct sunlight, near hot tables or near other heat sources could impair their efficiency.

Like other merchandisers, these are sensitive to air disturbances. Air currents passing around merchandisers will seriously impair their operation. Do NOT allow air conditioning, electric fans, open doors or windows, etc. to create air currents around the merchandisers.

Product should always be maintained at proper temperature. This means that from the

time the product is received, through storage, preparation and display, the temperature of the product must be controlled to maximize the life of the product.

SHIPPING DAMAGE

All equipment should be thoroughly examined for shipping damage before and during unloading. This equipment has been carefully inspected at our factory. Any claim for loss or damage must be made to the carrier. The carrier will provide any necessary inspection reports and/or claim forms.

Apparent Loss Or Damage

If there is an obvious loss or damage, it must be noted on the freight bill or express receipt and signed by the carrier's agent; otherwise, carrier may refuse claim.

Concealed Loss Or Damage

When loss or damage is not apparent until after equipment is uncrated, retain all packing materials and submit a written request to the carrier for inspection, within 15 days.

1-2 INSTALLATION

MERCHANDISERS SHIPPED WITH END INSTALLED

IMPORTANT: Be careful not to damage the factory installed end while moving the case. Make sure that tools are positioned past the end and beneath the merchandiser's support bar.

SHIPPING BRACES

Move the fixture as close as possible to its permanent location and then remove all packaging and shipping braces. Check for damage before discarding packaging. Remove all



separately packed accessories such as kits, and shelves.

Remove all nut retainers used with shipping braces. NSF certification requires the use of ANSI Standard nuts and bolts with not more than two (2) threads showing after installation.

SHIPPING RIDER

Each case is shipped on a rider to protect factory-installed legs, and to make positioning the case easier. Remove the rider after the case has been positioned.

Note: Once the rider is removed, the case must be lifted –NOT PUSHED– to reposition. To remove the rider, remove screws attaching each leg to rider. Remove screws holding rider cross-members, then slide cross-members out from between sides. Once cross-members are out, slide the sides out.



This warning does not mean that Hussmann products will cause cancer or reproductive harm, or is in violation of any product-safety standards or requirements. As clarified by the California State government, Proposition 65 can be considered more of a 'right to know' law than a pure product safety law. When used as designed, Hussmann believes that our products are not harmful. We provide the Proposition 65 warning to stay in compliance with California State law. It is your responsibility to provide accurate Proposition 65 warning labels to your customers when necessary. For more information on Proposition 65, please visit the California State government website.

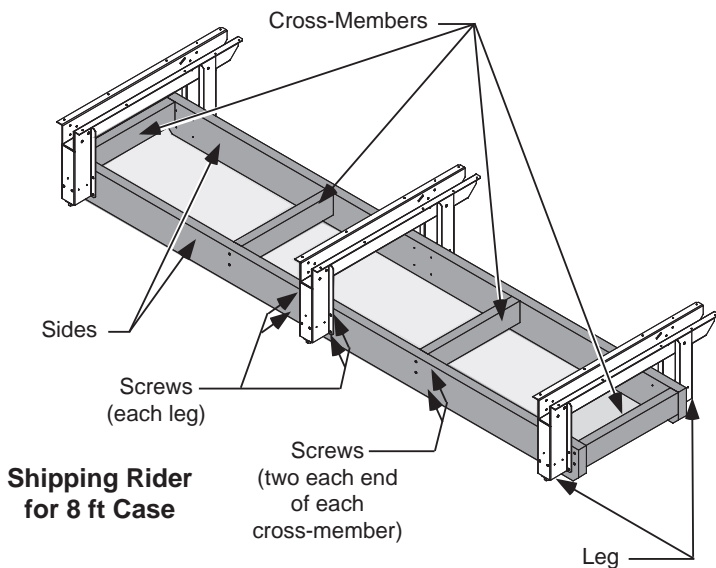



CAUTION

Read before raising front glass to prevent injury from broken or falling glass.

The top cylinders, which allow the raising and lowering of this glass, have been carefully installed and tested for the proper tension before shipment. However, during shipment and storage, the lubricant inside the cylinders may have settled. This settling can cause excessive or uneven tension on the glass to the point of breakage.

To avoid any damage, please do the following before completely raising the front glass.

1. Slowly raise and lower each glass section 6 times to a height of 6 in. (152 mm).
2. Increase the height to about 12 in. (305 mm) and raise and lower the glass 6 times.
3. Then raise the glass to the full extension and lower.

This should release any settled lubricant in the cylinders and prevent any stress on the front glass. Leveling and adjustment procedures begin on Page 1-3.

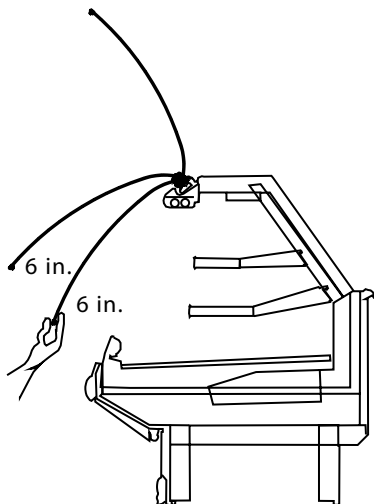

CASE LEVELING

Merchandisers must be installed level to ensure proper operation of the refrigeration system and to ensure proper drainage of defrost water. During all steps of setting, joining and leveling cases, close attention to glass position and operation must be maintained. Please review all steps and photos before making any adjustments. **DO NOT** make any glass adjustments until individual case is set and level.

Preparation

1. Using store blueprints, measure off and mark on floor the exact dimensions/locations of the case footprint.
2. Snap a chalk line for the front and rear positions of the base legs.
3. Mark the location of each joint from front to back lines.
4. **FLOORS ARE NOT LEVEL!!!** When working with two or more cases to be joined, the whole lineup must be leveled on the same plane, left to right and front to back. This means that the entire lineup must be brought up to the level of the highest case in the lineup.

Along the lines previously marked, find the highest point of the floor by:

- Walking the floor and noticing any dips or mounds;
- Using a string level; and
- Using a transit.

1-4 INSTALLATION

Leveler Adjustment

Position the first case at the highest point. Set a long level (4 ft [1220 mm] or more) on the upper front panel of the case. Use an open-end wrench to turn leg levelers until the case is level from end to end and from front to back. Check all 6 legs on 8 ft (2438 mm) cases, or 8 legs on 12 ft (3658 mm) cases.

Note: To avoid removing concrete flooring, begin lineup leveling from the highest point of the store floor.

Attention to glass position is critical during the leveling process.

Adjusting leg levelers will affect the position of the glass. Make certain that the glass is square with the case, and does not interfere with other glass or case ends.

If the glass is still out of alignment, refer to the following *Front Glass Positioning* instructions.

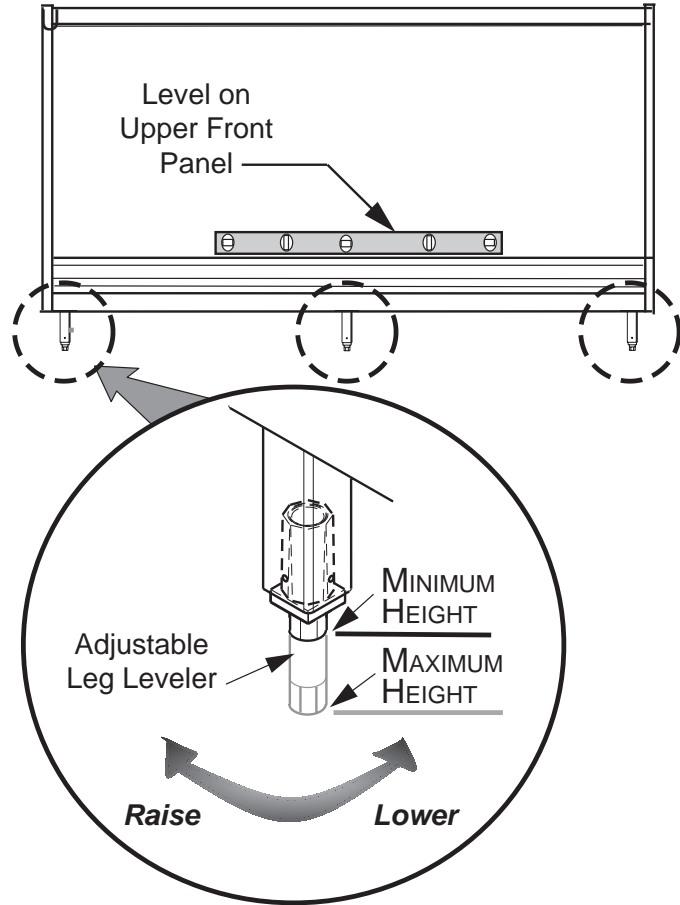

FRONT GLASS POSITIONING

CAUTION

To prevent injury from falling glass during adjustment, one person must support glass while a second person makes adjustments.

NOTICE

Do not adjust glass until case is level. In many instances, proper leveling will align glass without further adjustment.

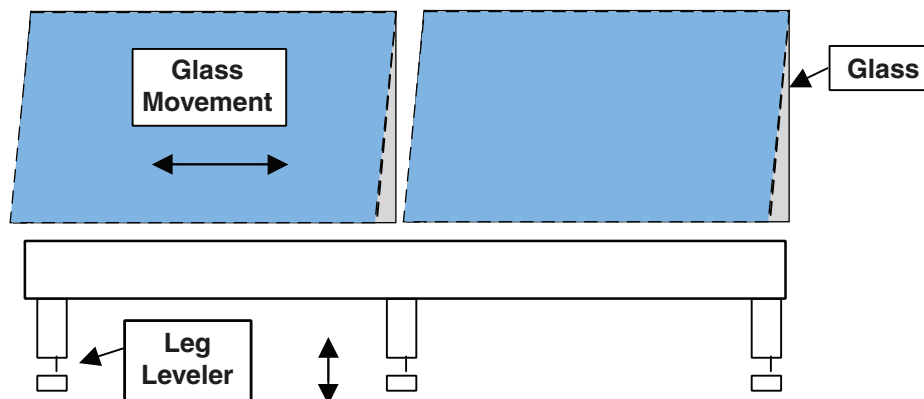

Vertical Adjustment

The position of the front edge of the glass is vertically adjustable to ensure proper fit. Do not attempt to make glass adjustments before leveling the case. All steps of setting, joining and case leveling are critical to glass position. Glass alignment may be affected if merchandisers are not leveled.

Check for level:

1. In a lineup position, first case is positioned at the highest point in the floor.
2. All 8 legs must be adjusted or shimmed to level case.
3. Check case level with a 4ft minimum level, also front to back. Place level on front glass contact point (top rail).

Front glass is adjusted from the factory. However, there may be instances when the glass may need adjustment in the field.

Joined or with ends

Check that glass is square with the case and does not interfere with other glass or case ends.

 <h2 style="margin: 0;">CAUTION</h2>
<p>To prevent injury from falling glass during adjustment, one person must support glass while a second person makes adjustments.</p> <p>Adjust all hinge assemblies on each case at the same time to prevent glass binding and breakage.</p>

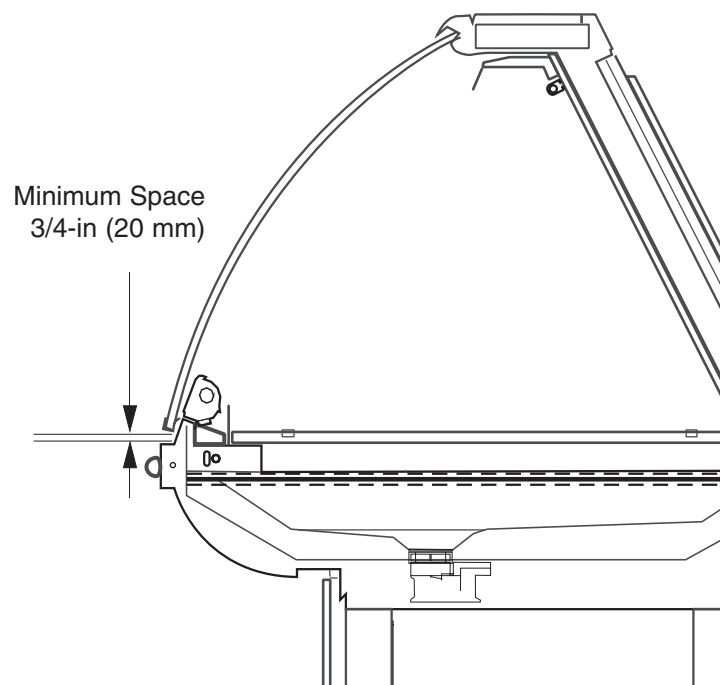

1-6 INSTALLATION

The front glass adjustment brackets are located and accessed at the rear of the case. To raise or lower the front edge of the glass:

1. Loosen the two side bolts.
2. **RAISE FRONT EDGE OF GLASS.** Loosen top extended bolt $\frac{1}{2}$ inch turn.
3. Tighten bottom bolt until edge of glass is level.

TO LOWER THE FRONT EDGE, reverse raising glass process.

DO NOT tighten one before loosening the other!

4. Tighten all bolts before installing back panel.

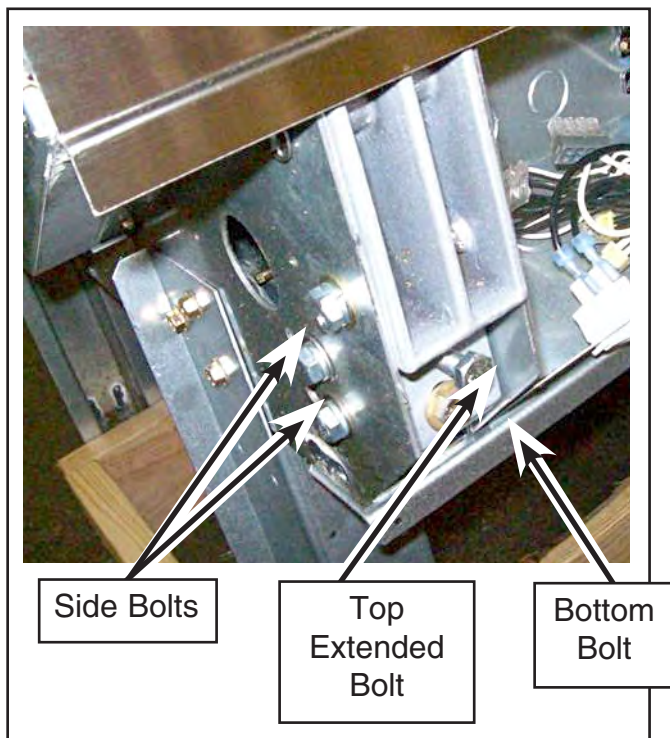

Horizontal Adjustment

Set screws at each end of the glass, and at center are shown below.

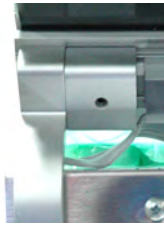

GLASS MUST
BE BOTTOMED
OUT IN HANDLE

Loosen tension on set screws, and reposition glass as necessary.

Tighten set screws.

Check the following to improve opening or closing of the case front glass.

1. Has the case been leveled according to the installation instructions. If not, level the case.
2. Is the glass handle installed correctly?
3. Verify the glass is bottomed out in the handle. The handle should not be bowed along its length. Bowing is an indication the handle is not properly installed.

If the handle is not positioned correctly, it must be removed. The handle is held in place with silicone. Remove the handle by pulling it away from the glass. **Do not use tools to pry handle from glass.** Old silicone must be cleaned off the handle and glass. Apply new silicone into the handle, and firmly press handle onto the glass.

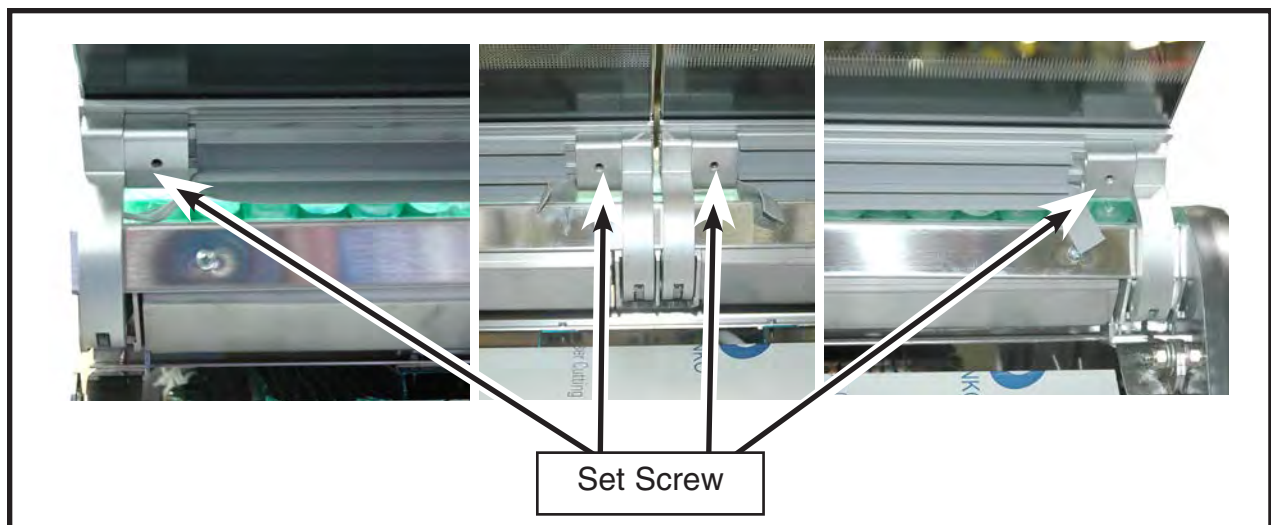
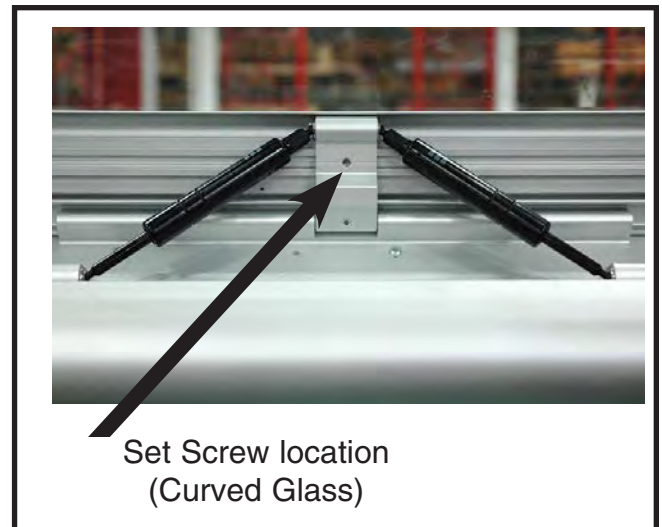

1-8 INSTALLATION

JOINING INSTRUCTIONS

Sectional construction means that two or more merchandisers may be joined in line yielding one long continuous display requiring only one pair of ends.

ALL JOINTS MUST BE AIR-TIGHT TO PREVENT FORMATION OF ICE OR CONDENSATION.

Prep Case

1. Check to be sure that merchandisers are level and that the factory-installed nut retainers and alignment pins are in place. Locate Joining Kit and check contents against parts list.
2. Remove shelves (if installed), display racks, pans, front shelf supports and front air grilles from the right end.

Apply Front Silicone Gasket Pad

1. Apply a continuous bead of silicone around the front joining hole.

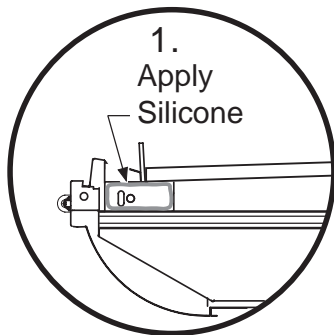

2. Remove paper backing from gasket pad and position the pad as shown.

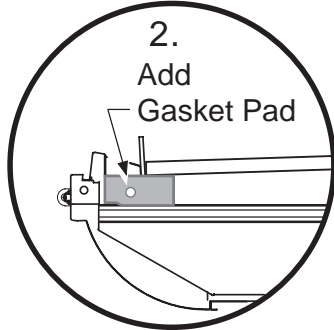

NOTICE

A wedge is not to be joined to another wedge. Wedges are designed for proper operation when joined to a parent case.

3. Apply another continuous bead of silicone on the gasket pad.

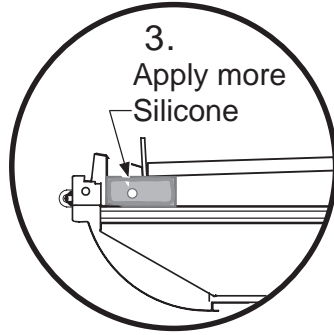

Apply Silicone to Canopy and Strut

1. Apply a continuous bead of silicone around the canopy.

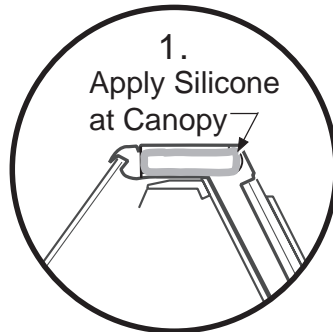

2. Apply a continuous bead of silicone around the strut.

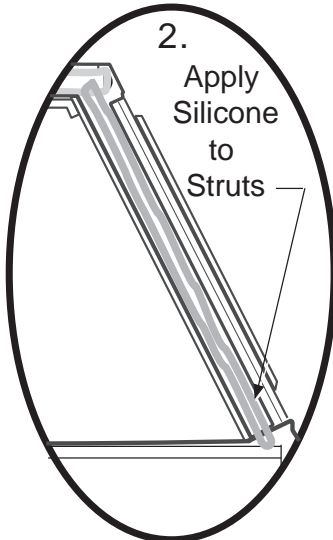

There should be no gaps in the silicone bead from the canopy to the gasket channel below the strut.

Apply Gaskets

1. Apply 1/2 in. (13 mm) gasket in the recess across the bottom of the case as shown.
2. Apply silicone across bottom to ensure no gaps from front of canopy around back and bottom to front gasket pad.

IMPORTANT

- Do not stretch gasket, especially around corners.
- Do not butt gaskets; always lap them as shown.
- Remove paper backing after gasket has been applied.

Fasten Cases

1. Move the second case into position against the first. Match the alignment pin with the corresponding hole.
2. Fasten fronts together using 5/16-18 joining bolt, flat washer, lock washer and nut. Tighten only until front panels touch.
3. Use the 5/16-18 joining bolts, flat washers, lock washers and nuts provided to draw the cases together at rear brackets as shown.

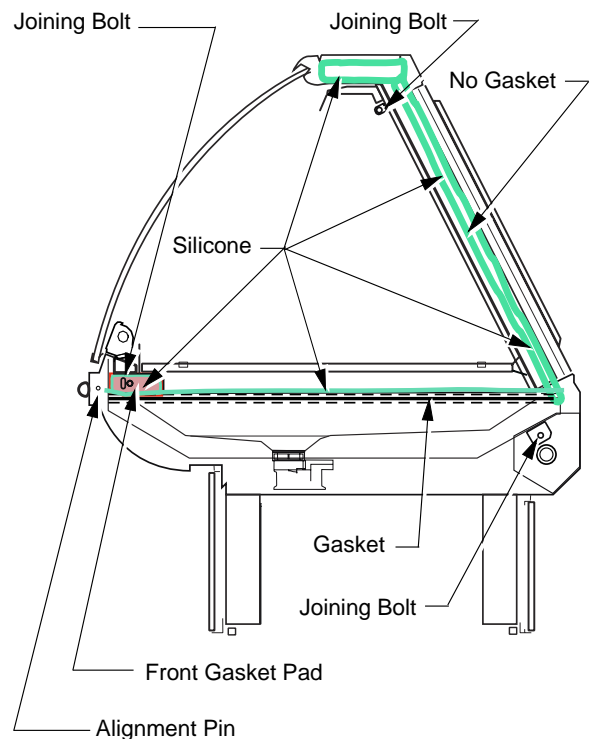

1-10 INSTALLATION

Seal Merchandisers

1. Apply butyl tape across the bottom joint. Be sure to extend the tape up the back and front of the case.

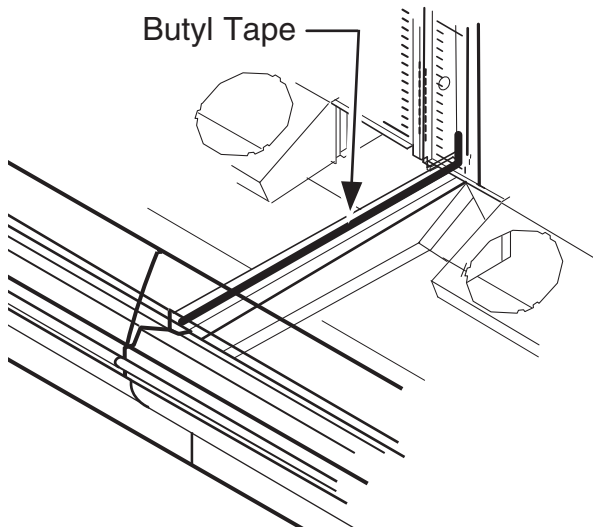

2. Use field-supplied silicone to fill any gaps between the front support brackets.

INSTALLING BUMPERS

Elite bumpers are shipped as a continuous roll. Once installed the continuous bumper helps to disguise the joint locations, giving the lineup a smoother look.

1. Unroll the bumper and allow it to rest at room temperature for **24 hours prior to installation** to minimize bumper shrinkage after installation.
2. Slide end caps onto retainer at right and left ends of lineup. Align with slot in retainer, then fasten with screws provided.

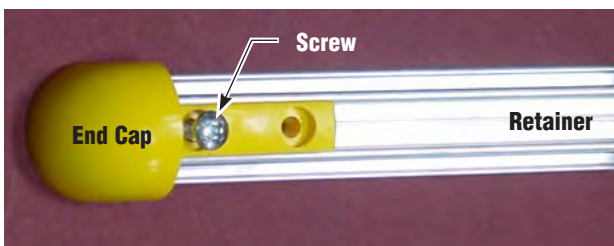

3. Measure the distance between inside end of caps and add $\frac{1}{8}$ inch (3 mm) for each 4 ft (1220 mm). Adding the additional material will compensate for stretching which occurs during installation.

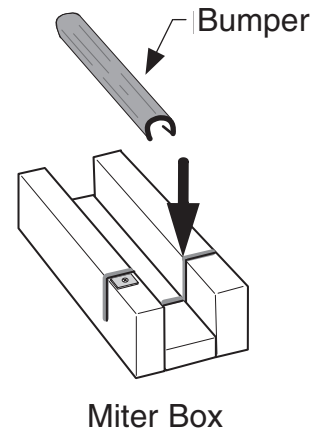

4. Cut the bumper to length with a miter saw for a precise, right-angle cut.
5. Lubricate the inside of the vinyl with soapy water or silicone spray.
6. Starting at the left end of the line up, butt end of the vinyl bumper against end cap. While applying pressure, bend back vinyl top so that vinyl legs are positioned within the base grooves. Roll vinyl bumper over full length of retainer, then tap with rubber mallet to ensure vinyl is securely locked into retainer.
7. If necessary wipe clean with any household cleaning product.

INSTALLING PARTITIONS

To join same temperature fixtures on different defrost cycles, an acrylic partition kit is required.

To join unlike fixtures, or like fixtures operating at different temperatures, a 1 in. (26 mm) insulated connecting partition kit is required.

Instructions for installing these partitions are included with the kits.

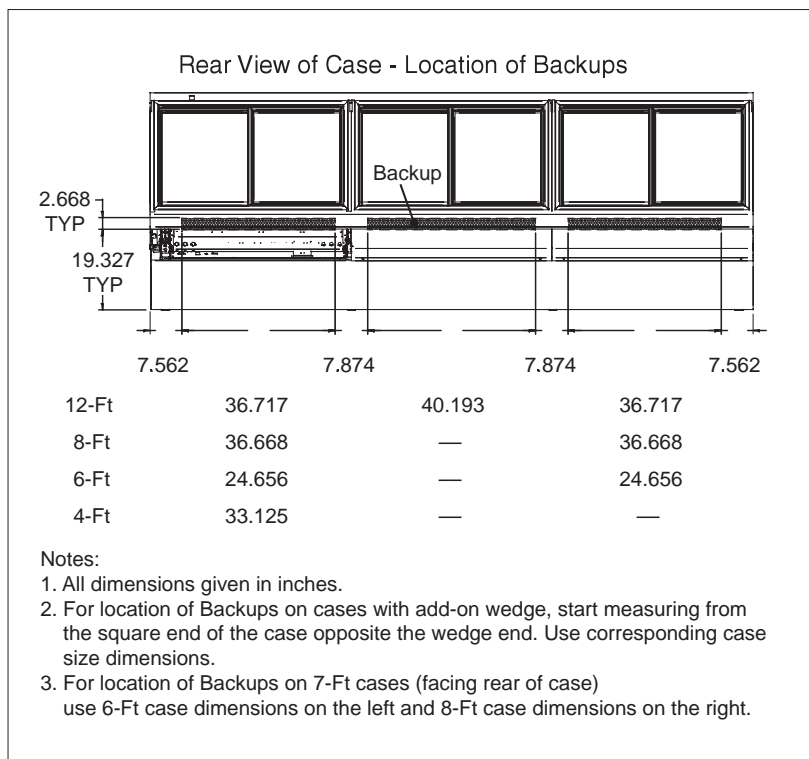

1-12 INSTALLATION

Installing Optional Wrap Board MOA 0470438

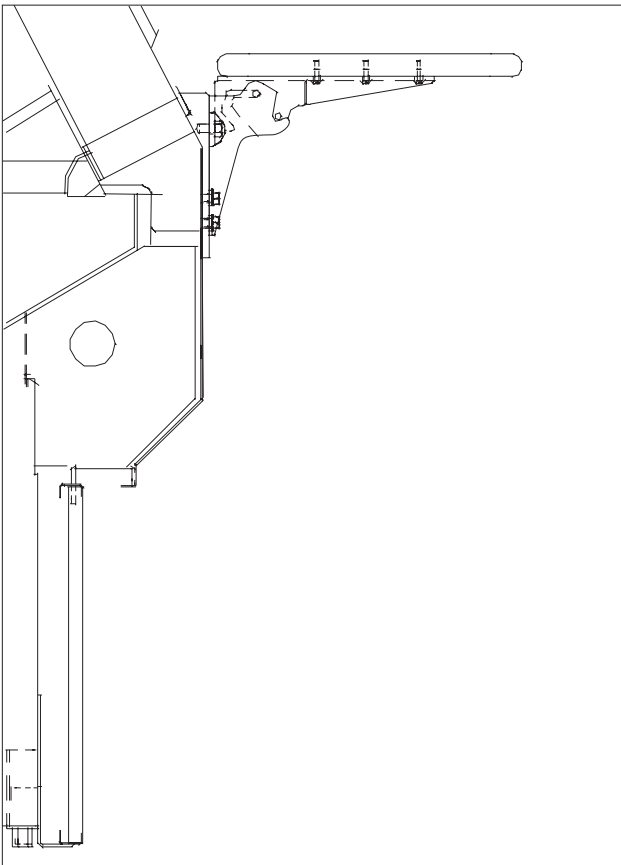

1. Turn off power to case.
2. Determine location by positioning the wrap board on the rear of the case between door frames.
3. Align the assembly on the back of the case as shown below.
4. Using holes in wrapping board bracket as a template, mark hole locations on rear of case.
5. **Remove wireway cover; make sure there are no wires behind hole locations.**
6. Drill $\frac{3}{8}$ -inch (0.1875) diameter holes for three $\frac{1}{4}$ -20 thread cutting screws through stainless steel and structural members.
7. Securely fasten brackets to case.

8. Adjust wrapping board as needed. The attach points for hinging brackets on wrap board is determined by which position the assembly is to be mounted. Refer to figures for LH, RH or Center mounting positions.

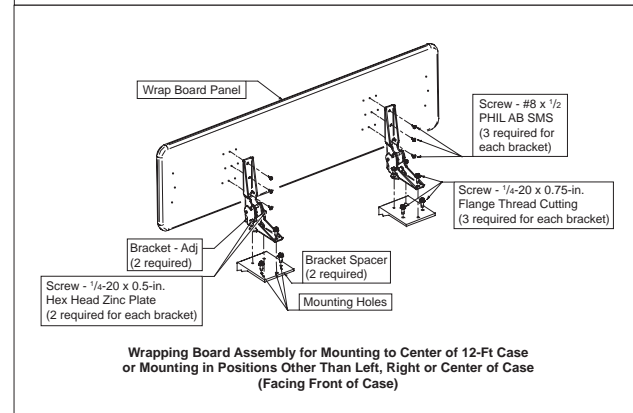
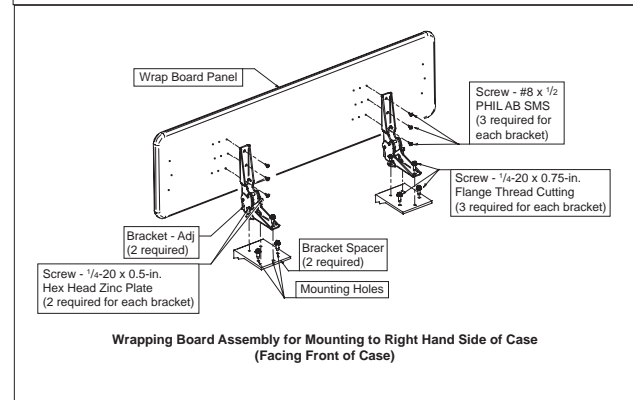
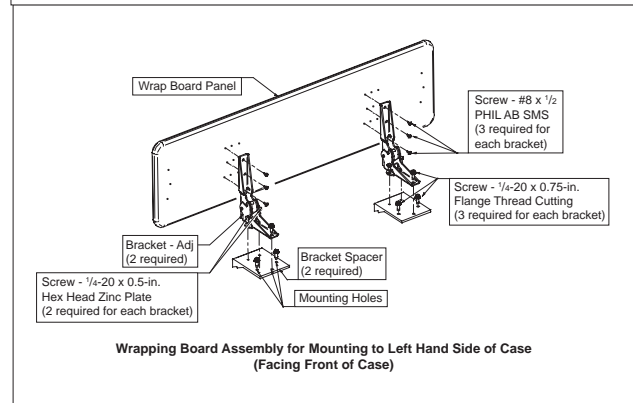
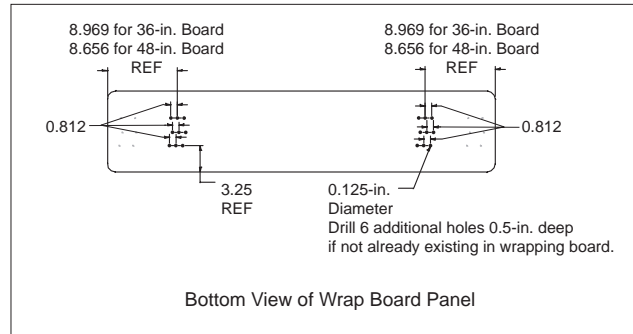

9. Replace wireway cover.
10. Restore power.

Installing Optional Scale Stand

MOA 0458960

1. Turn off power to case.
2. Determine location by positioning the scale stand on the rear of the case between door frames.
3. Using holes in scale stand bracket as a template, mark hole locations on rear and top of case.
4. Remove scale stand. Drill 1/8-inch diameter pilot holes through metal liners at the marked locations.

NOTE: METAL LINERS ARE LESS THAN 1/8-INCH THICK-- DO NOT DRILL BEYOND METAL LINERS.

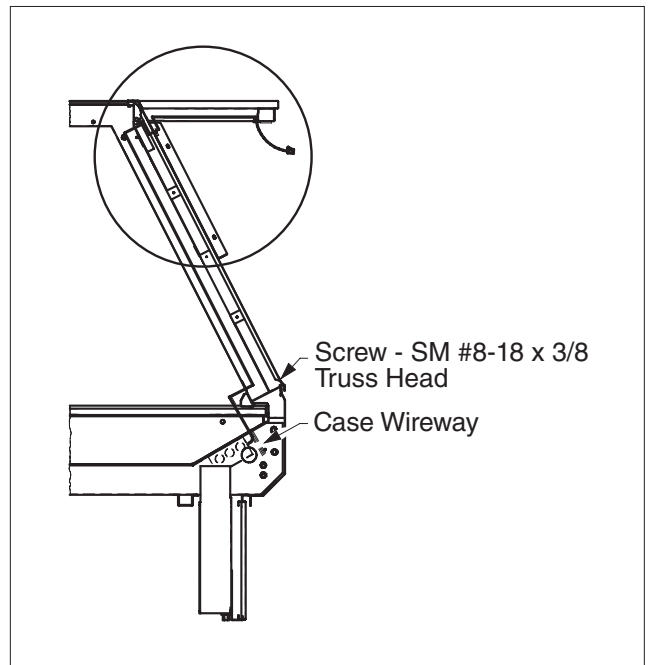

6. *NOTE: RECEPTACLE HARNESS WIRING MUST HAVE INSULATION SLEEVE INSTALLED PRIOR TO ROUTING.* Leaving about 12 inches of harness hang out of case, route receptacle harness wiring from the 3/4-in. bushing, down the LH upright wireway through hole and into case wireway.

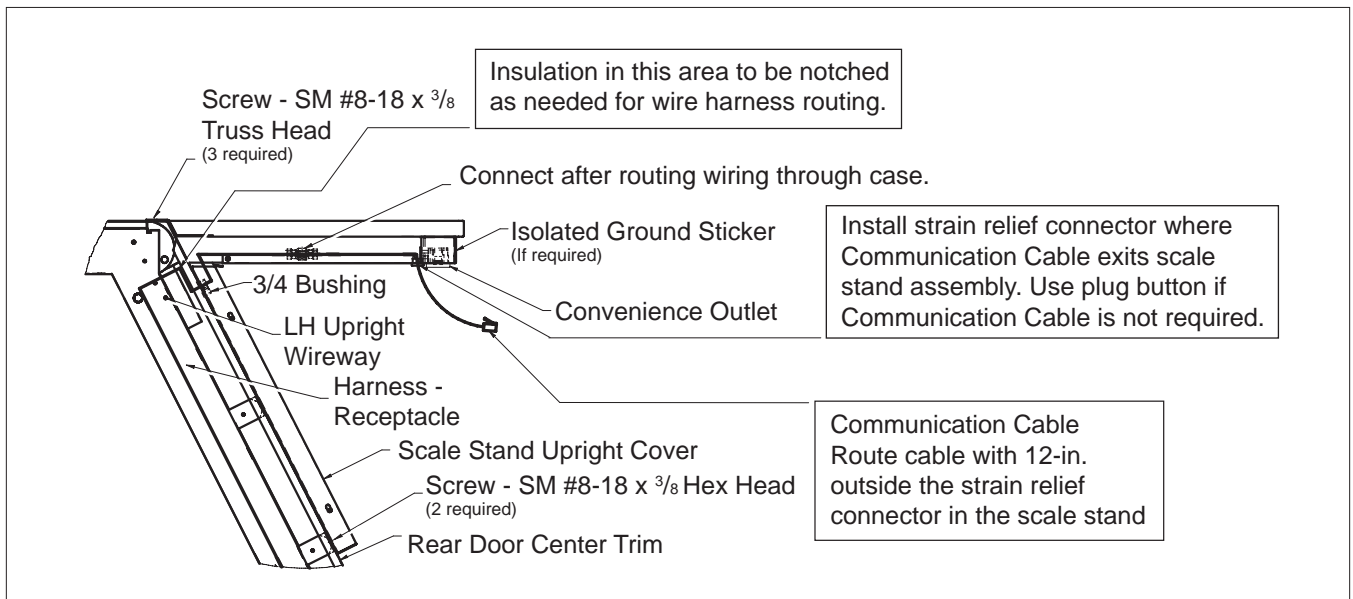

5. Move top panel away from back of case. Remove center rear door trim and remove LH Upright wireway cover to allow routing of receptacle harness.

NOTE: COMMUNICATION CABLE WIRING CAN BE ROUTED SIMILARLY.

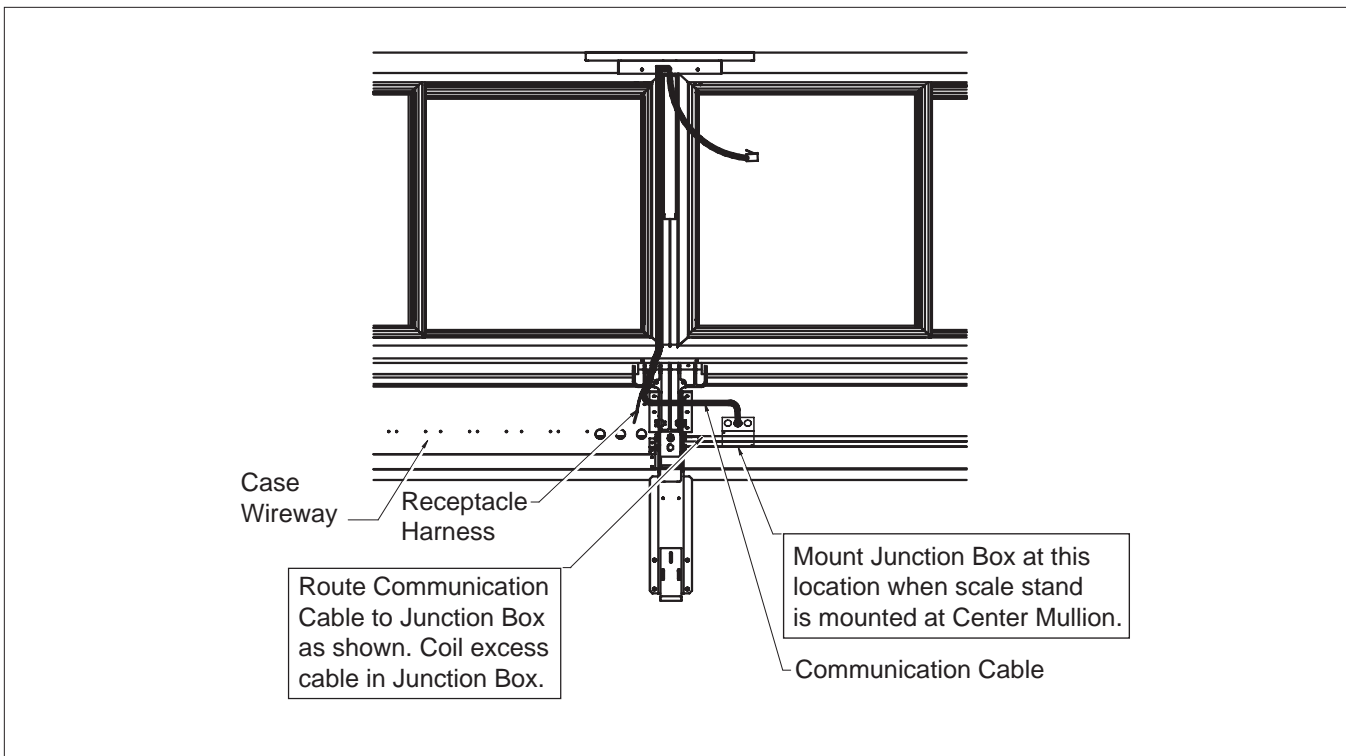

7. Install the rear door center trim with $\frac{3}{4}$ -in. bushing by routing wire harness

through $\frac{3}{4}$ -in. bushing and attach with #8 truss head screws.

8. Reposition top over rear door center trim and attach using #8 truss head screws.

9. Reposition scale stand and attach using #8 truss head screws.

10. Install scale stand upright cover with #8 blunt tip sheet metal screws.

11. Connect wiring to power in wireway.

12. Restore power. Check for proper operation.

Some stores specify an isolated ground for scale stand convenience outlets. If required, apply the following:

- Isolated ground sticker to scale stand.
- Isolated ground tag to ground wire in case wireway.

REFRIGERATION / ELECTRICAL

REFRIGERANT

The correct type of refrigerant will be stamped on each merchandiser's serial plate. The case refrigeration piping is factory sealed, pressurized and leak tested. Before making refrigeration hookups, depress universal line valve to ensure that coils have maintained pressure during shipment.

! WARNING

Refrigerant vapor is hazardous to your health and can cause death.

Avoid breathing refrigerant and lubrication vapor or mist. Exposure may irritate eyes, nose and throat. If accidental system discharge occurs, ventilate work area before resuming service.

Always wear safety goggles and protective gloves when working with refrigerants. Contact with refrigerant may cause injury. Disconnect hoses with extreme caution! All hoses may contain liquid refrigerant under pressure.

Be sure that any room where you are working is thoroughly ventilated, especially if a leak is suspected.

Read all safety information regarding the safe handling of refrigerant and refrigerant oil, including the Material Safety Data Sheet. MSDS sheets can be obtained from your refrigerant supplier.

Refrigeration lines are under pressure and should be depressurized before attempting to make any connections.

When brazing pipes, be sure to use the insulation blanket shipped with the merchandiser to prevent fire or damage to the plastic case bottom.

REFRIGERANT PIPING

Connection Location

The refrigerant line connections are at the right-hand end of the merchandiser (as viewed from the front) beneath the display pans. A sticker marks the location of the connection "pod." The installer must saw a hole through the pod to exit the case. After connections have been made, seal this outlet thoroughly. Seal both the inside and the outside. We recommend using an expanding polyurethane foam insulation.

Multiplexing

Piping of merchandisers operating on the same refrigeration system may be run from merchandiser to merchandiser. **DO NOT RUN REFRIGERANT LINES THROUGH MERCHANDISERS THAT ARE NOT ON THE SAME REFRIGERATION SYSTEM BRANCH** as this may result in poor refrigeration control and compressor failure.

Interconnecting piping inside the merchandiser must be located as shown below to allow room for lifting the hinged fan plenums and for clearance beneath the display pans. The interconnecting piping may be run outside the merchandiser.

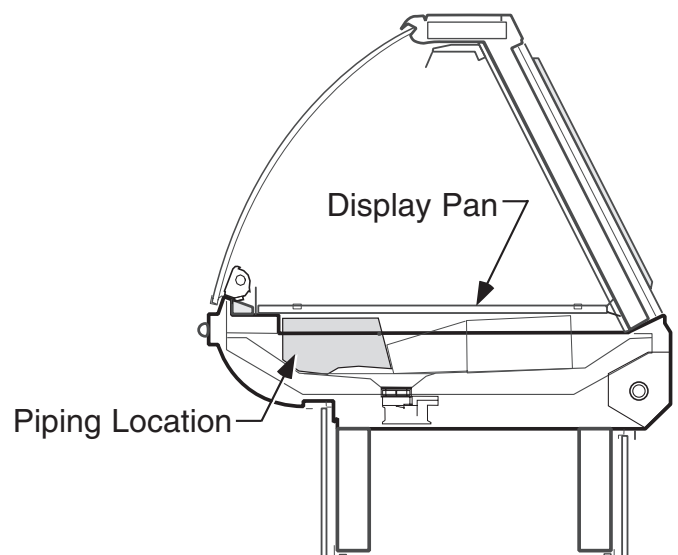

2-2 REFRIGERATION / ELECTRICAL

Line Sizing

Refrigerant lines should be sized as shown on the refrigeration legend that is furnished for the store or according to ASHRAE guidelines. Refer to the information on the next page for branch line piping of Hussmann Equipment.

Oil Traps

P-traps (oil traps) must be installed at the base of all suction line vertical risers.

Pressure Drop

Pressure drop can rob the system of capacity. To keep the pressure drop to a minimum, keep the refrigerant line run as short as possible using a minimum number of elbows. Where elbows are required, USE LONG RADIUS ELBOWS ONLY.

INSULATION

The suction and liquid lines should be clamped or taped together and insulated for a minimum of 30 ft (9144 mm) from the merchandiser. Additional insulation for the balance of the liquid and suction lines is recommended wherever condensation drippage is objectionable or lines are exposed to ambient conditions.

SUCTION LINE

- Pitch in direction of flow.
- May be reduced by one size at one third of case run load and again after the second third. Do not reduce below the case suction line size.
- Case suction lines should enter at the top of the branch line.

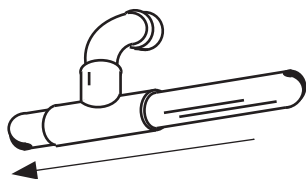

Suction Line Return

LIQUID LINE

- May be reduced by one size after one half the case run load. Do not reduce below the case liquid line connection size.
- Take-offs to case liquid lines should exit the bottom of the branch liquid line. Provide an expansion loop for each evaporator take-off. (Minimum 3 in. [76 mm] loop.)

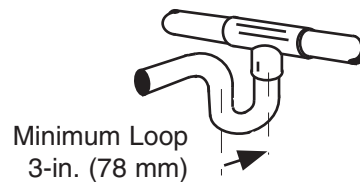

Liquid Line Take Off

CONTROL SETTINGS

Merchandiser data sheets are shipped with this manual. The data sheets provide case control settings and defrost data.

An evaporator pressure regulator or EPR (primary control) and a 3 – 5°F (1.7 – 2.7°C) differential thermostat (secondary control) must control refrigeration temperature. The EPR must be set to maintain the proper saturated evaporator temperature as listed in the data sheets. The thermostat must be set a couple degrees colder than the discharge air temperature specified in the data sheets. The thermostat will prevent product freezing should the EPR temperature drift downward during reduced load periods (lights off, lower ambient). The thermostat will be wired to control the compressor motor contactor (single compressor) or a liquid line solenoid valve (parallel compressor systems).

Offtime Defrost

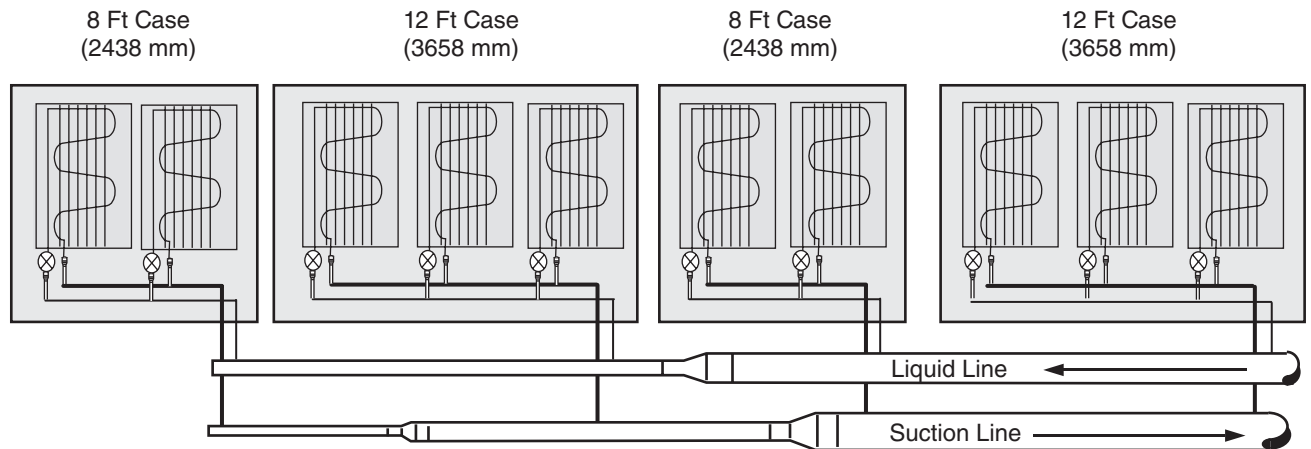

Defrost is Off Time. Defrost control settings are listed in the data sheets. When these merchandisers are connected to parallel compressor systems, a suction stop valve must be used to isolate the evaporator during defrost periods.

REFRIGERATION THERMOSTAT

The bulb for the optional refrigeration thermostat is located in the discharge air of the evaporator. The optional refrigeration thermostat is located behind the exterior rear panel.

DEFROST TERMINATION THERMOSTAT

The standard disc type defrost termination thermostat is not adjustable. This thermostat is clamped to the inlet of the coil on the left-hand (facing front) end of the merchandiser.

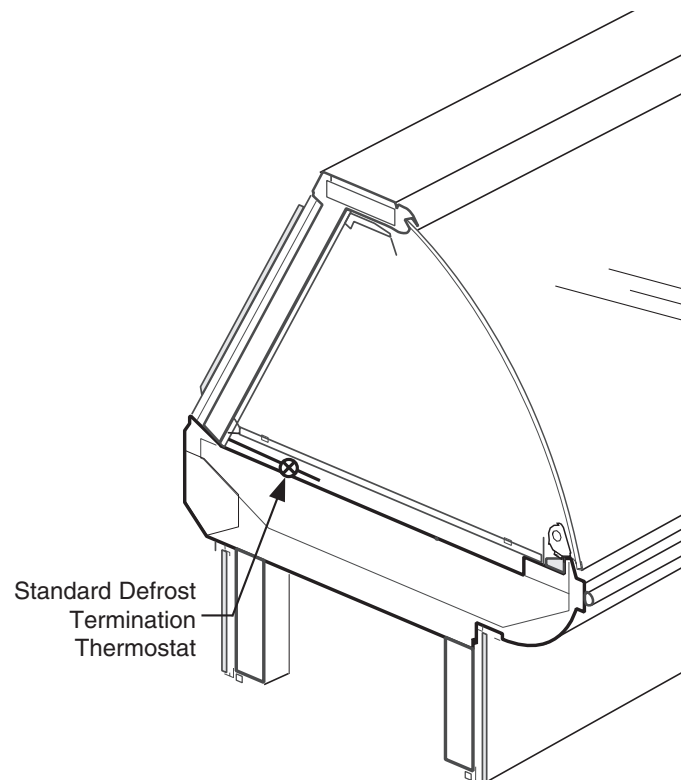

MERCHANDISER ELECTRICAL DATA

Technical data sheets are shipped with this manual. The data sheets provide merchandiser electrical data, electrical schematics, parts lists and performance data. Refer to the technical data sheets and merchandiser serial plate for electrical information.

ELECTRICAL CONNECTIONS

All wiring must be in compliance with NEC and local codes. All electrical connections *including both supply circuits* are to be made in the electrical *Handy Box*.

FIELD WIRING

Field wiring must be sized for component amperes stamped on the serial plate. Actual ampere draw may be less than specified. Field wiring from the refrigeration control panel to the merchandisers is required for defrost termination thermostats and for optional refrigeration thermostats.

IDENTIFICATION OF WIRING

Leads for all electrical circuits are identified by colored plastic bands. These bands correspond to the *color code sticker* (shown below) located inside the merchandiser's wireway cover.

ALWAYS CHECK THE SERIAL PLATE FOR COMPONENT AMPERES



...ATTENTION
INSTALLER

It is the contractor's responsibility to install merchandiser(s) in accordance with all local building and health codes.

! WARNING

— LOCK OUT / TAG OUT —

To avoid serious injury or death from electrical shock, always disconnect the electrical power at the main disconnect when servicing or replacing any electrical component. This includes, but is not limited to, such items as doors, lights, fans, heaters, and thermostats.

WIRING COLOR CODE

Leads for all electrical circuits are identified by a colored plastic band: neutral wire for each circuit has either White insulation or a White plastic sleeve in addition to the color band.

- | | |
|--|--|
| PINK..... REFRIG. THERMOSTAT LOW TEMP. | ORANGE OR |
| LIGHT BLUE . REFRIG. THERMOSTAT NORM TEMP. | TANLIGHTS |
| DARK BLUE.. DEFROST TERM. THERMOSTAT | MAROON ..RECEPTACLES |
| PURPLE CONDENSATE HEATERS | YELLOW ...DEFROST HEATERS 120V |
| BROWN..... FAN MOTORS | REDDEFROST HEATERS 208V |
| GREEN* GROUND | *EITHER COLORED SLEEVE OR COLORED INSULATION |

**ELECTRICIAN NOTE: Use copper conductor wire only.
MERCHANTISER MUST BE GROUNDED**

THESE ARE MARKER COLORS. WIRES MAY VARY.

DRIP PIPING AND SPLASHGUARDS

WASTE OUTLET AND WATER SEAL

The waste outlet is located in front of the fan plenum 6 ft (1829 mm) from the left-hand of the merchandiser (facing case front) allowing drip piping to be run under the fixture lengthwise. A 1¹/₂ in. (38 mm) water seal is supplied with each fixture. The water seal must be installed to prevent air leakage and insect entrance into the fixture. A tee, adapter, ell, and plug have been shipped to allow field installation to determine direction of drain.

INSTALLING DRIP PIPING

Poorly or improperly installed drip pipes can seriously interfere with the operation of these merchandisers, and result in costly maintenance and product losses. Please follow the recommendations listed below when installing drip pipes to ensure proper installation.

1. Never use drip piping smaller than the nominal diameter of the pipe or water seal supplied with the merchandiser.
2. When connecting drip piping, the water seal must be used as part of the drip piping to prevent air leakage or insect entrance. Never use two water seals in series in any one drip pipe. *Double water seals in series will cause an air lock and prevent draining.*
3. Pitch the drip piping in the direction of flow. There should be a minimum pitch of 1/4 in. per ft (20 mm per 1 m).

4. Avoid long runs of drip piping. Long runs make it impossible to provide the pitch necessary for good drainage.

5. Provide a suitable air break between flood rim of the floor drain and outlet of drip pipe. To meet code on low base merchandisers, it may be necessary to install a field-supplied drip pipe reducer. An alternative is to cut the last section of drip pipe at an angle.
 

6. Prevent drip pipes from freezing:
 - A. Do NOT install drip pipes in contact with uninsulated suction lines. Suction lines should be insulated with a non-absorbent insulation material.
 - B. Where drip pipes are located in dead air spaces, such as between merchandisers or between a merchandiser and a store wall, provide means to prevent freezing.

Note: To prevent condensation problems, the water seal should be insulated.

Do not apply pipe thread sealer to ABS drain fitting or the fitting may crack or become damaged.

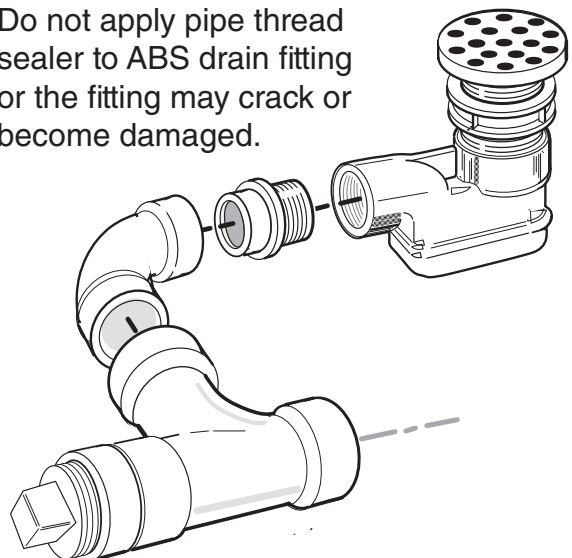

3-2 DRIP PIPING AND SPLASHGUARDS

INSTALLING LOWER FRONT PANELS

The lower front panels are shipped inside each merchandiser. **AFTER** merchandisers have been leveled and joined, and all drip piping, electrical and refrigeration work has been completed, install the lower front panel.

To Install Lower Front Panel

1. The lower front panel supports are designed to fit into the slots on the top of the lower front panel.
2. Once the top is positioned, lift the panel up and drop it over the tabs on the front close-off brackets.

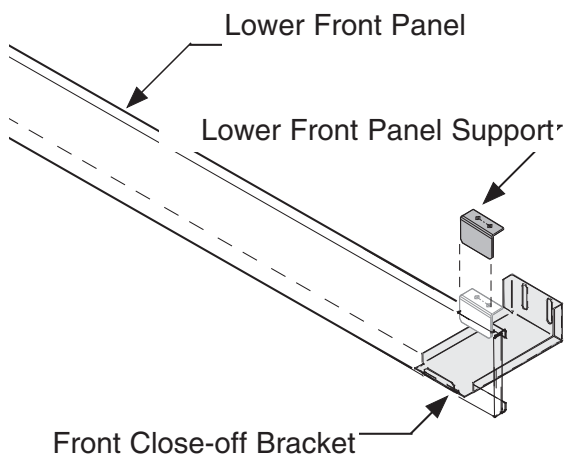

Space between the Lower Front Panel and the floor may be covered using a vinyl cove base trim (field supplied). The size of trim needed will depend on how much the floor is out of level.

To install the trim to the front panel:

1. Remove all dirt, wax and grease from the area of the lower front panel where adhesion will be necessary. This is to ensure a good and secure installation.
2. Apply a good contact cement to the cove trim and allow proper drying time according to the directions supplied with the cement.
3. Install the trim on the lower front panel so that it is lying flush with the floor. **DO NOT SEAL THE TRIM TO THE FLOOR.**
4. **If required by local health codes** the Cove Trim may be sealed to the floor, using a silicone type sealer. Sealant must be removed and replaced when servicing.

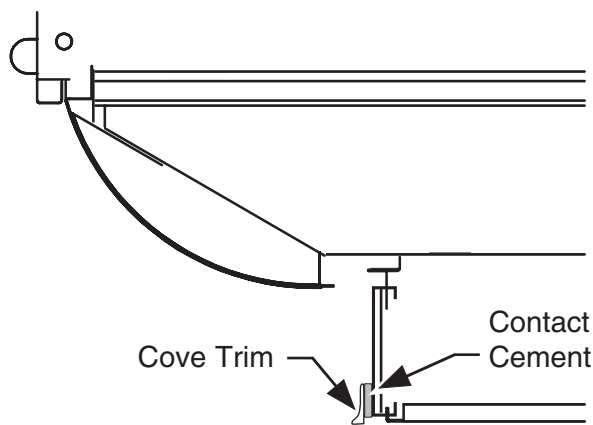

INSTALLING BOTTOM REAR PANEL

For fixed installation:

1. Align slots in bottom rear panel with center of legs.
2. Drive a hex head sheet metal screw through each slot into each leg.

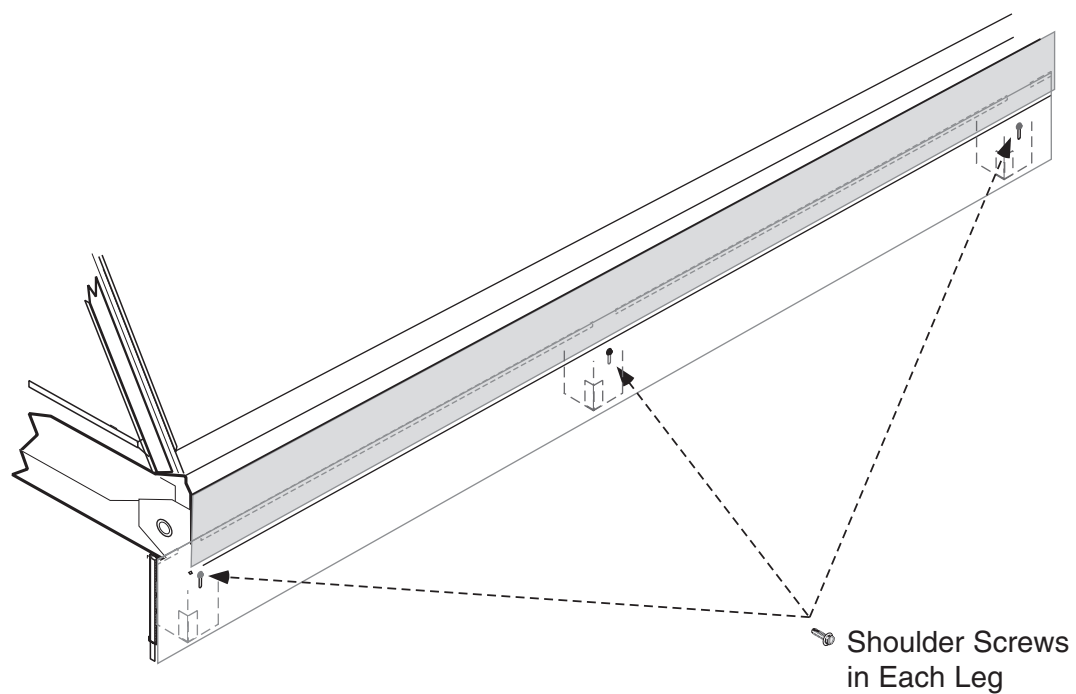

3-4 DRIP PIPING AND SPLASHGUARDS

Notes:

START UP / OPERATION

START UP

See the specific merchandiser's Data Sheet Set for refrigerant settings and defrost requirements. Bring merchandisers down to the operating temperatures listed on the data sheet.

Each 4 ft (1219 mm) section has its own evaporator coil and pre-set non-adjustable thermostatic expansion valve (TEV). No adjustment is required. **DO NOT REMOVE THE CAP ON THE TEVs.** This cap is to be removed only for valve disassembly.

The TEV has been factory set to provide the recommended performance settings as specified on the merchandiser data sheets.

 <h2 style="margin: 0;">CAUTION</h2>
<p>Removal of the TEV cap will result in refrigerant loss unless the system is first isolated and the refrigerant recovered.</p>

LOAD LIMITS

Each merchandiser has a load limit decal.

Recommended load limit profiles are shown on the next page.

Shelf life of perishables will be short if load limit is violated. Overstocking will adversely affect product temperature and merchandiser efficiency.



DO NOT BLOCK AIR GRILLE.

LOAD LIMIT PROFILES

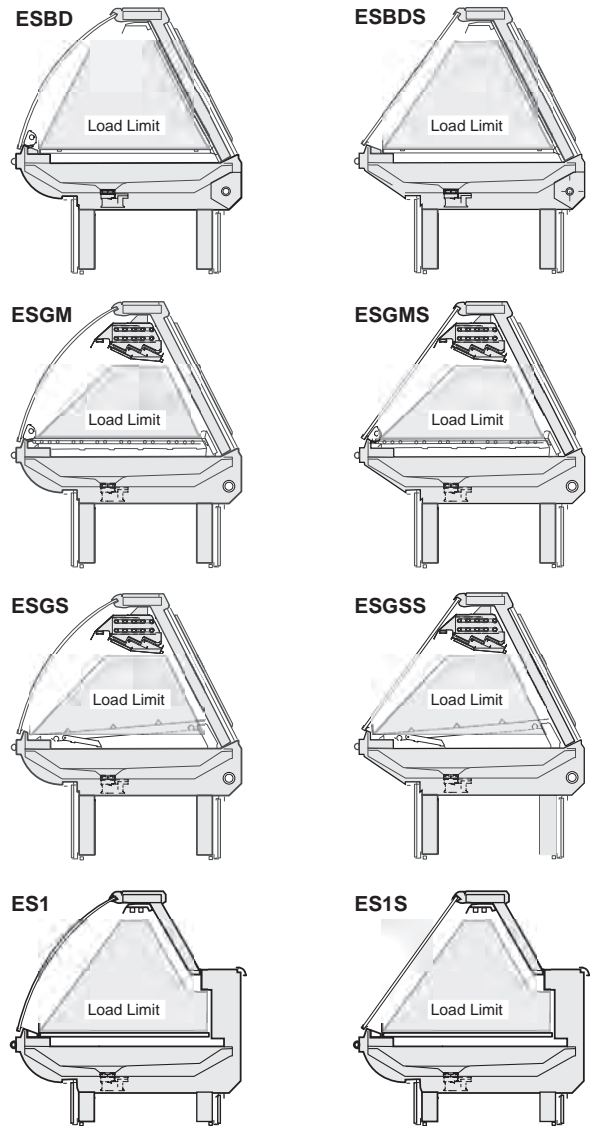

 <h2 style="margin: 0;">WARNING</h2>
<p>At no time should merchandisers be stocked beyond the load limits indicated. Improper stocking can cause poor performance that results in spoiled food.</p>

STOCKING

Product should NOT be placed in merchandisers until case is at proper operating temperature.

Proper rotation of product during stocking is necessary to prevent product loss. Always bring the oldest product to the front and set the newest to the back.

AIR DISCHARGE AND RETURN FLUES MUST REMAIN OPEN AND FREE OF OBSTRUCTION AT ALL TIMES to provide proper refrigeration and air curtain performance. Do not allow product, packages, signs, etc. to block these grilles. Do not use non-approved shelving, baskets, display racks, or any accessory that could hamper air curtain performance.

INSTALLING SHELVES

Begin with the lowest row of shelves. Verify the shelf brackets are at 90 degrees to shelf. Keep shelf level from side to side while tilting the front down to insert the lowest tab in the shelf upright. Use a level on each shelf, or count slots in each upright and mark with tape to ensure rows of shelves stay level. Tabs must be seated firmly into position in the uprights before loading shelves.

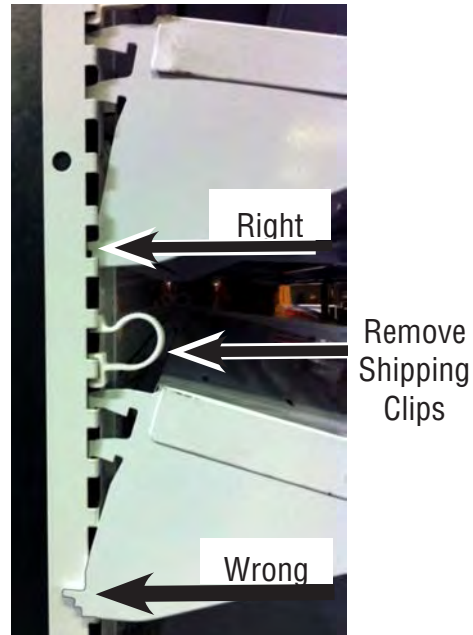

⚠ WARNING

— LOCK OUT / TAG OUT —

To avoid serious injury or death from electrical shock, always disconnect the electrical power at the main disconnect when servicing or replacing any electrical component. This includes, but is not limited to, such items as doors, lights, fans, heaters, and thermostats.

IMPORTANT!

Ambient air curtain fans must operate at all times. Verify that these fans are working properly before starting up merchandiser.

⚠ WARNING

Do NOT stand or walk on top of merchandiser because. Do not place items or flammable materials atop the unit.



MULTI-DECK SHELF ALIGNMENT

Taped to one of the shelves of each merchandiser is a small plastic bag containing shelf alignment strips. These strips are designed to enhance the appearance of the shelves by aligning the front edge of each shelf with that of an adjacent shelf.

When installing shelves:

1. Insert one of the alignment strips into the slot behind the front edge of each shelf.
2. After all shelves are installed, slide the strip across the shelf joint wherever two shelves are adjacent. This will lock them together.

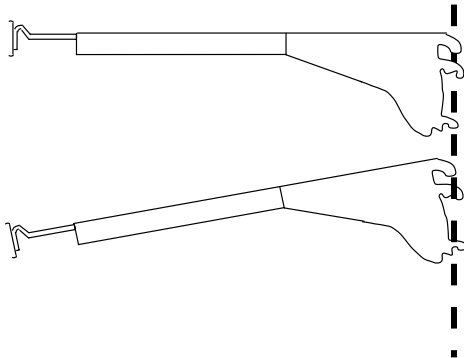

MULTI-DECK SHELF ALIGNMENT (Optional Shelf Alignment Strips)

Taped to one of the shelves of each merchandiser is a small plastic bag containing shelf alignment strips. These strips are designed to enhance the appearance of the shelves by aligning the front edge of each shelf with that of an adjacent shelf.

When installing shelves:

1. Insert one of the alignment strips into the slot behind the front edge of each shelf.
2. After all shelves are installed, slide the strip across the shelf joint wherever two shelves are adjacent. This will lock them together.

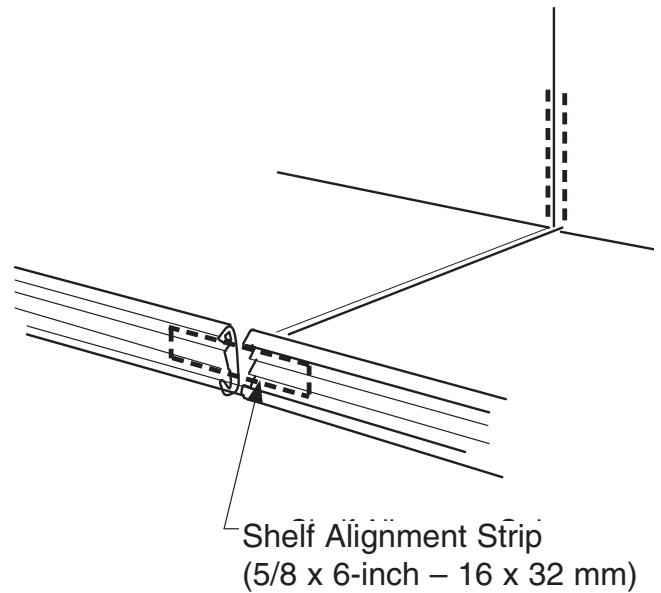

SHELF MAXIMUM WEIGHT LIMITS

Hussmann merchandiser shelves are designed to support the maximum weight load limits as indicated in the table below. Exceeding these maximum weight load limits may cause damage to the shelf or shelves, damage to the merchandiser, damage to store products, and potentially create a hazardous condition for customers and staff. Exceeding the indicated maximum weight load limits constitutes misuse as described in the Hussmann Limited Warranty.

Weight Limits for Merchandiser Shelving

Nominal Shelf Depth	Maximum Load Limit
8 in. (203 mm)	100 lb (45.3 kg)
10 in (254 mm)	125 lb (56.7 kg)
12 in. (305 mm)	125 lb (56.7 kg)

*Shelf load limits at 0° tilt

4-4 START UP / OPERATION

LED LIGHT FIXTURES

If your merchandiser has LED fixtures (light emitting diode), the procedure for installing the lighted shelves is the same. However, instead of ballasts that run fluorescent lamps, your merchandiser is equipped with 24VDC power supply that provides DC power to operate the LEDs. EcoShine II LED lights work well for dimming or on/off operation using an occupancy sensor (optional kits).

They can be turned on and off in a cold environment with no warm-up time and no negative impact on lamp life. Hussmann EcoShine II LED light fixtures normally perform for up to 50,000 hours.



LED Shelf Light Plug

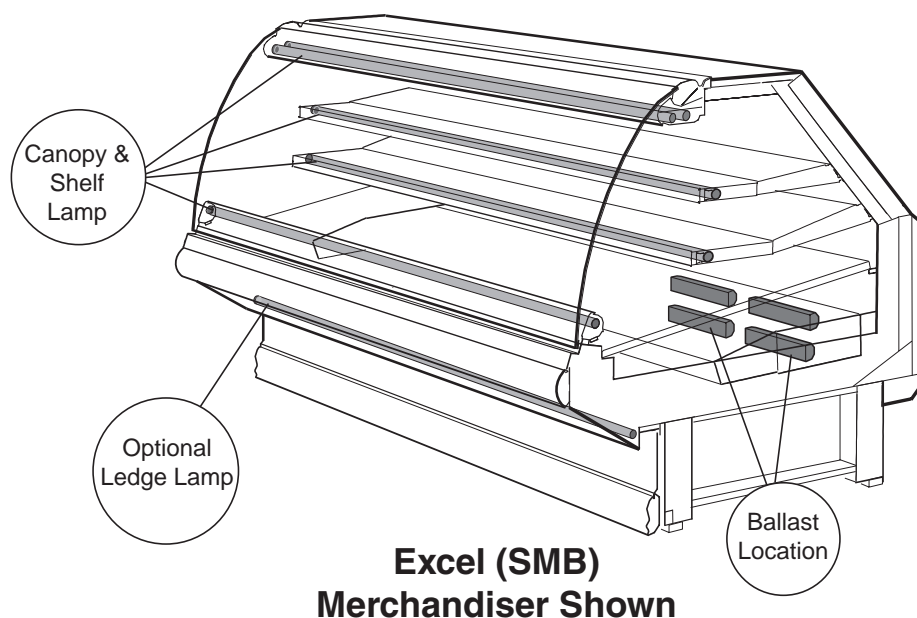

LED Shelf Light Receptacle

FLUORESCENT FIXTURES

The ballasts used in Excel models have built-in anti-arc protection. An electrical arc may occur if a shelf plug is not seated properly, or if a lamp is not properly seated in a lampholder. The ballast will shut down when it detects an arc. Two to four lamps will be out in the merchandiser when this occurs. Carefully check the plugs to make sure they are fully seated, and check the lamps to ensure they are firmly seated in the lamp-holders on the affected shelves. To reset a ballast that has ‘tripped’ on anti-arc, turn off the merchandiser light switch for a minimum of 15 seconds, then turn it on.

Note: The ballasts used in *Elite* models have built-in anti-arc protection. An electrical arc may occur if a shelf plug is not seated properly, or if a lamp is not properly seated in a lampholder. The ballast will shut down when it detects an arc. Two to four lamps will be out in the merchandiser when this occurs. Carefully check the plugs to make sure they are fully seated, and check the lamps to ensure they are firmly seated in the lamp-holders on the affected shelves. To reset a ballast that has ‘tripped’ on anti-arc, turn off the merchandiser light switch for a minimum of 15 seconds, then turn it on.

PROCEDURE FOR INSTALLING LIGHTED SHELVES

Follow these instructions to ensure good contact between male and female connectors.

1. Remove produce from shelf and place in cooler.

SHUT OFF POWER TO THE MERCHANDISER.

2. Turn off Canopy Light Switch. Remove all packed shelves.
3. Remove shelf connectors from power sockets. Always grip shelf connector by the handle when removing from socket. **PULL handle DOWN AND THEN OUT to disengage.** Note that latch tongue must depress to disengage plug.



Fluorescent Shelf Light Plug



Fluorescent Shelf Light Receptacle

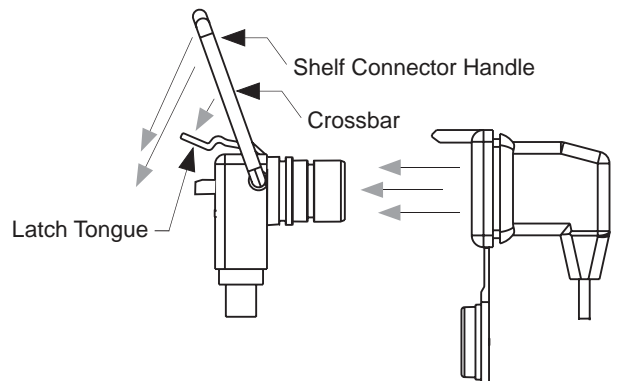

⚠ WARNING
 — LOCK OUT / TAG OUT —
 To avoid serious injury or death from electrical shock, always disconnect the electrical power at the main disconnect when servicing or replacing any electrical component. This includes, but is not limited to, such items as doors, lights, fans, heaters, and thermostats.

4-6 START UP / OPERATION

4. **Engage each power socket cap and ensure that each cap is fully seated before cleaning.** Ensure the proper seating of the cap at all times when the plug is not engaged.



5. Clean the merchandiser as described in the **Care and Cleaning** paragraphs of *Section 5 – Maintenance*. **Keep liquid out of sockets.**
6. Verify that power is at the merchandiser and turned on. Verify that the merchandiser light switch is turned “OFF.” Switch is located in the canopy, on the left, behind first row of lamps.

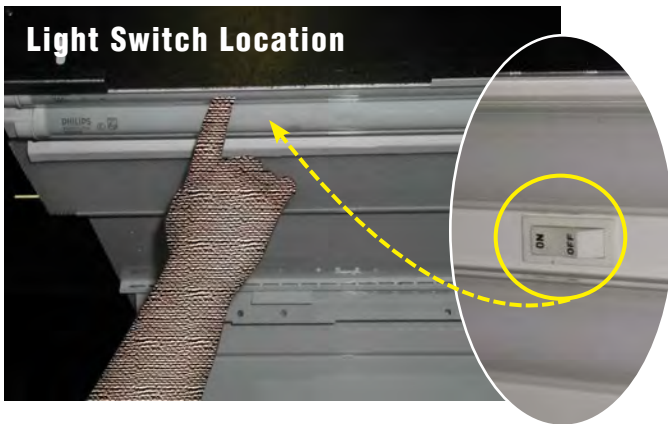

7. Note that some models have fewer rows of shelves. Starting from the left-hand bottom section, choose the location for the first shelf. Secure the shelf in the slotted upright. **It is important that shelf brackets be properly seated in the slotted upright.**

8. Turn “ON” the merchandiser light switch after all rows are installed.

Note: LED lamps use a 24VDC power supply.

If a shelf fluorescent light does not operate:

- A. Turn off light switch.
- B. Make certain the shelf lamps are properly engaged in the shelf lamp holders.
- C. Remove and firmly re-insert each shelf plug.
- D. Turn on light switch.

INSTALLING FDA/NSF REQUIRED THERMOMETER

The following pages provide the same information that ships with the thermometer.

This requirement does not apply to display refrigerators intended for bulk produce (refer to page 1-1).

Please note that the tape cannot be exposed after installation.

This is an NSF-7 & US FDA Food Code Required Thermometer

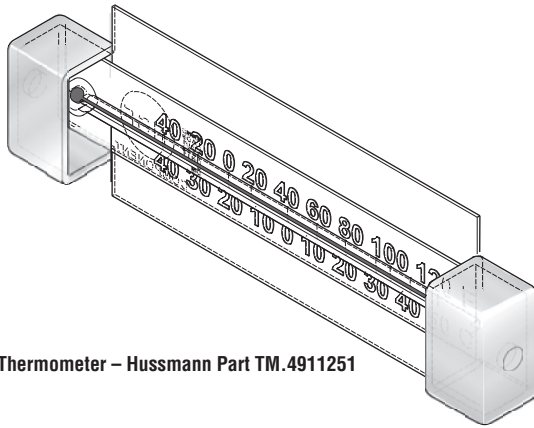

Thermometer – Hussmann Part TM.4911251

Hussmann Corporation • 12999 St. Charles Rock Road • Bridgeton, MO 63044-2483
U.S. & Canada 1-800-922-1919 • Mexico 1-800-522-1900 • www.hussmann.com
© 2007 Hussmann Corporation

Suggested Mounting Locations in Single Deck Glass Front Impact Merchandisers

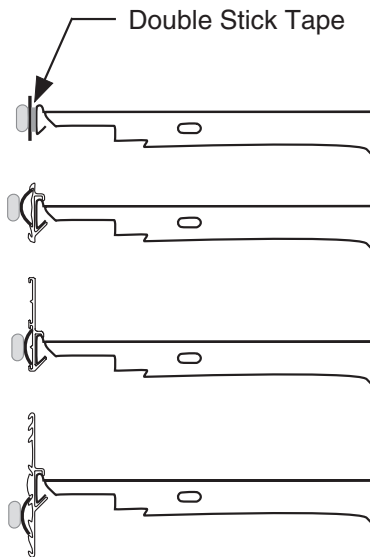
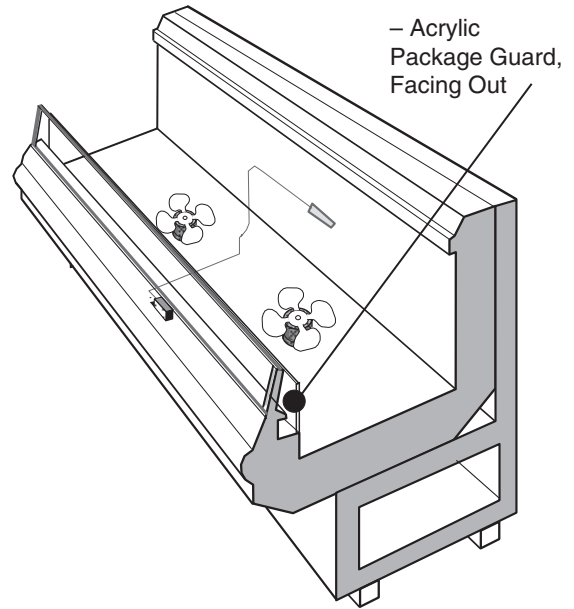

Flexible Plastic Fits in Price Tag Moldings

Hussmann P/N 0429971_C

10/2007

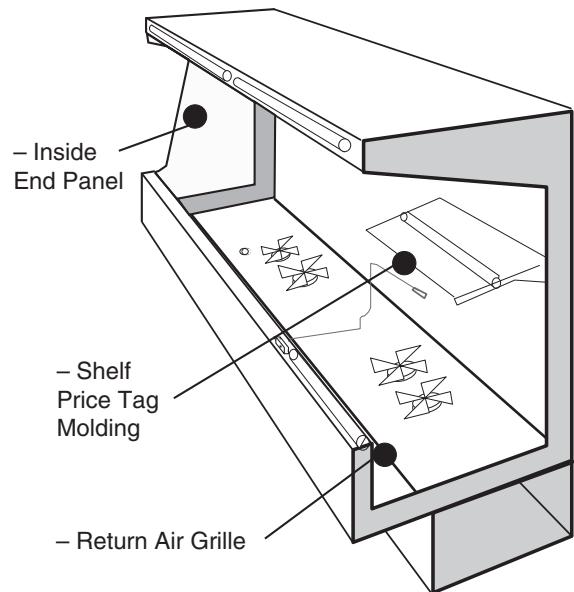

Suggested Mounting Locations in Multi-deck Merchandisers

Important – Please read!

This thermometer is provided in response to United States
Food and Drug Administration (US FDA) Food Code [<http://www.fda.gov/>]
and
National Sanitation Foundation (NSF / ANSI) Standard 7 [<http://www.nsf.org/>]

Each installation will be different depending on how the unit is stocked, shopping patterns in the department and ambient conditions of the store. The suggested locations provided herein are possible locations. It is the responsibility of the purchaser / user to determine the location with the food storage area of the unit that best meets the code requirements above.

The thermometer may need to be moved several times to find the warmest location. Mounting options include flexible plastic for price tag molding application, magnet applied to back of flexible plastic for steel end wall, and double stick tape. Tape must not be exposed after installation.

Questions about either code should be addressed to local agencies or other appropriate officials.

**Keep with merchandiser
or give to store manager.**

DO NOT DESTROY.

MAINTENANCE

CARE AND CLEANING

Regularly scheduled maintenance by a qualified technician will add to the life span of the equipment and save energy because units run more efficiently if they are well maintained. Minor repairs can prevent or delay major replacements, and minimize unscheduled downtime and loss of productivity.

Long life and satisfactory performance of any equipment is dependent upon the care it receives. To ensure long life, proper sanitation and minimum maintenance costs, these merchandisers should be thoroughly cleaned, all debris removed and the interiors washed down, at least weekly.

Anti-Reflective Glass

While the anti-reflective coatings are durable, they are susceptible to scratching if abrasive materials are used for cleaning. Once the glass surfaces are scratched, it is impossible to restore the original finish. Special care must be taken to prevent damage when cleaning the glass.

Anti-reflective glass can be cleaned with clear water or any non-alkaline detergent. However, it is very important to use a soft cloth, a micro-fiber cleaning cloth or a wet sponge.

Never use the following types of materials to clean glass with anti-reflective coatings:

- Coarse Paper Towels
- Scouring Pads or Powders
- Steel Wool or Steel Fiber Materials
- Blades
- Acidic or highly Alkaline detergents
- Fluorine based detergents



WARNING

**Prevent injury.
ALWAYS SHUT POWER OFF
during cleaning process.**

Exterior Surfaces

The exterior surfaces must be cleaned with a mild detergent and warm water to protect and maintain their attractive finish. **NEVER USE ABRASIVE CLEANSERS OR SCOURING PADS.**

Interior Surfaces

The interior surfaces may be cleaned with most domestic detergents, ammonia based cleaners and sanitizing solutions with no harm to the surface. Removable parts are labeled: **REMOVE FOR CLEANING.**

Removable stainless steel parts may be cleaned and sanitized in dishwasher. Detailed direction is provided later in this Section.



CAUTION

Do NOT use HOT water on COLD glass surfaces. This can cause the glass to shatter and could result in personal injury. Allow glass fronts, ends, and service doors to warm before applying hot water.



WARNING

Product will be degraded and may spoil if allowed to sit in a non-refrigerated area.

Do Not Use:

- Abrasive cleansers and scouring pads, as these will mar the finish.
- A hose on lighted shelves or submerge the shelves in water.
- Solvent, oil or acidic based cleaners on any interior surfaces.

Do:

- Remove the product and all loose debris to avoid clogging the waste outlet.
- Store product in a refrigerated area such as a cooler. Remove only as much product as can be taken to the cooler in a timely manner.
- **Turn off refrigeration, then disconnect electrical power.**
- Thoroughly clean all surfaces with mild detergent and water (105 to 140°F / 40 to 60°C). **DO NOT USE STEAM OR HIGH WATER PRESSURE HOSES TO WASH THE INTERIOR. THESE WILL DESTROY THE MERCHANDISER'S SEALING CAUSING LEAKS AND POOR PERFORMANCE.**
- Lift or remove fan plenum for cleaning. Hook chain in rear panel to secure plenum during cleaning. Be sure to reposition the fan plenum after cleaning merchandiser.
- Take care to minimize direct contact between fan motors and cleaning or rinse water.
- Rinse with water, but do NOT flood. **NEVER INTRODUCE WATER FASTER THAN THE WASTE OUTLET CAN REMOVE IT.**

- Allow merchandisers to dry before resuming operation.
- After cleaning is completed, turn on power to the merchandiser.

INTERIOR CLEANING STEPS

STEP 1 – Remove product to cooler.

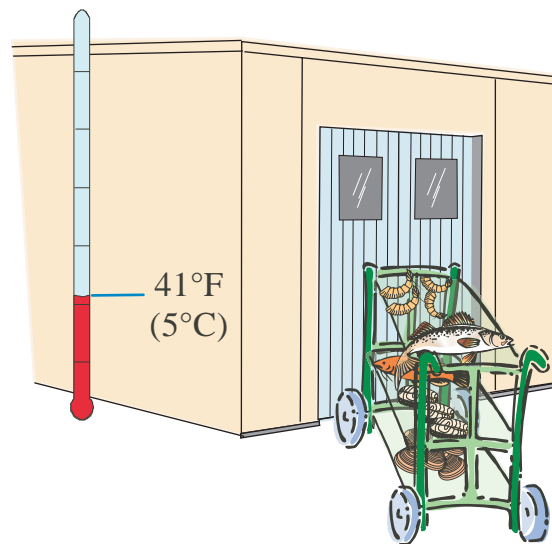

STEP 2 – Turn off refrigeration.

Note that refrigeration controls and power controls are not in the merchandiser. Consult the store legend or facility manager.

STEP 3 – Shut power off.

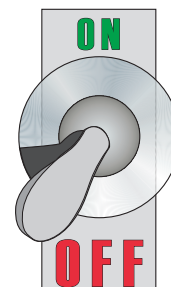

⚠ WARNING
 Product will be degraded and may spoil if allowed to sit in a non-refrigerated area.

STEP 4 – Unplug shelves and close receptacle caps, then remove shelves.

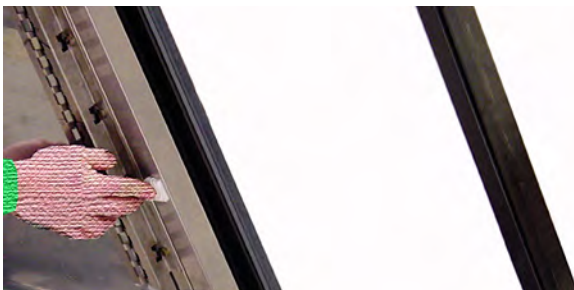

⚠ WARNING
 PREVENT INJURY.
 ALWAYS SHUT OFF POWER
 DURING CLEANING PROCESS.

STEP 5 – Remove display pans.



STEP 6 – Lift out discharge air grille.

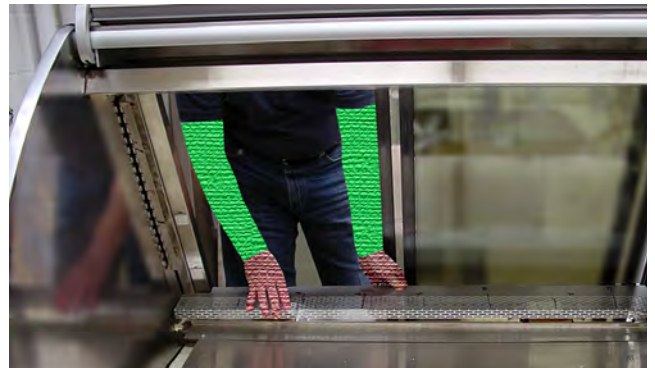

STEP 7 – Lift out interior back panel (if equipped).

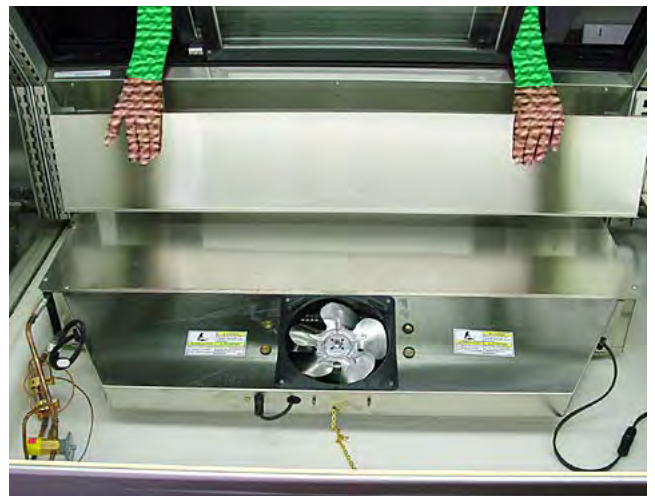

5-4 MAINTENANCE

STEP 8 – Lift out return air grille (from front).



OR

Unplug fan harness.



STEP 9 – (IF EQUIPPED) Rotate fan plenum up and back; hook chain at rear of liner.

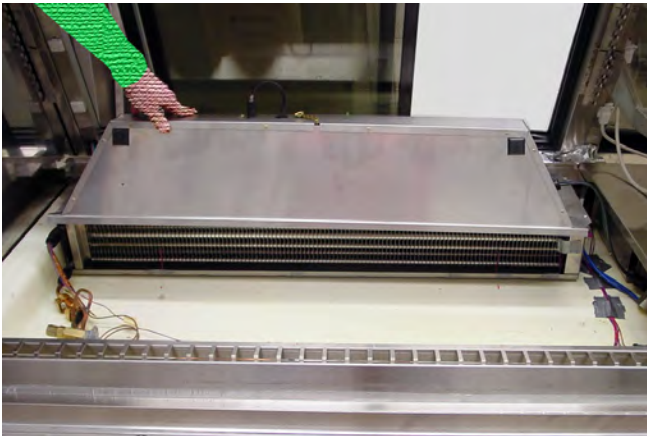

Lift fan plenum up and back to remove. (view is from the back)

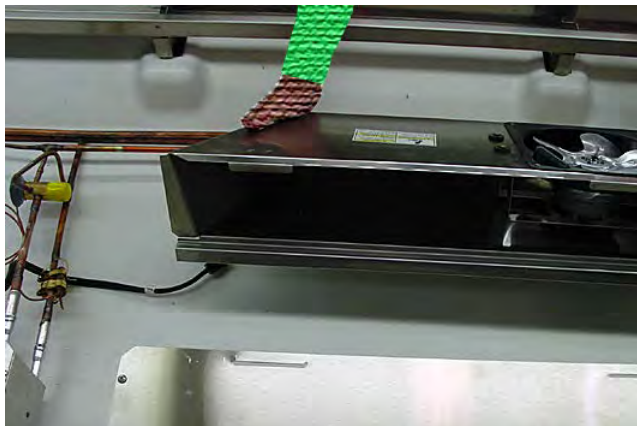
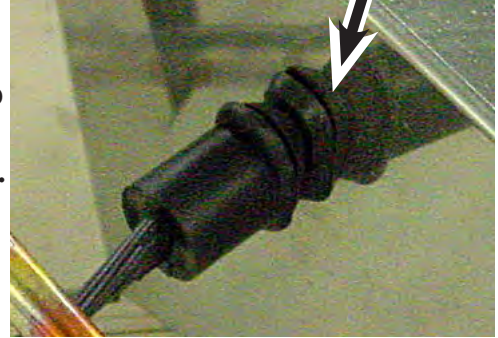

STEP 10 – Clean drip pan assembly (gravity cases).

Work from the rear of the case. Doors may be lifted out for easier access to the drip tray. Follow directions on label above the doors as shown at right.

Separate the drip tube from the lower end of the connector as shown below.

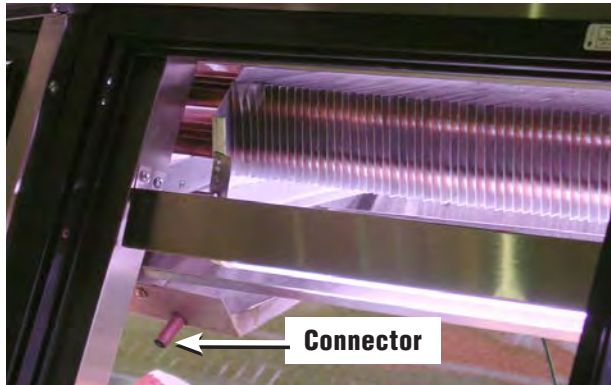

The drip tray assembly consists of sections. Plates connect the sections in 6-, 8-, and 12-ft cases. For better control, begin at the outside retainers and work toward the middle. Insert fingers into the retainer and rotate to the side as shown in detail photos. **Support the drip tray when rotating the last retainer.** Once the last retainer is disengaged, the entire drip tray assembly will rotate down and forward.

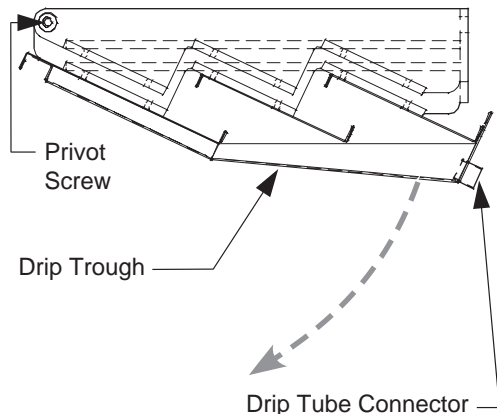

Drip Pan Assembly



CLEANING COILS

NEVER USE SHARP OBJECTS AROUND COILS. Use a soft brush or vacuum brush to clean debris from coils. Do not puncture coils! Do not bend fins. Contact an authorized service technician if a coil is punctured, cracked, or otherwise damaged.

ICE in or on the coil indicates the refrigeration and defrost cycle is not operating properly. Contact an authorized service technician to determine the cause of icing and to make adjustments as necessary. To maintain product integrity, move all product to a cooler until the unit has returned to normal operating temperatures.

5-6 MAINTENANCE

Use a sponge or soft cloth to hand wash the drip tray assembly. Sanitize the drip tray assembly and drip tubes. Use paper towel- ing to dry inside and outside of the assembly before reinstalling.



To reinstall the drip tray assembly, rotate it back and up until retainers can be engaged. Support the assembly until the center retain- er has been rotated and is fully engaged, then work toward each end. Verify that each retainer is fully engaged. Reinsert the drip tube connector into the drip tube.



STEP 11 – Clean inside the merchandiser.

Once interior parts have been removed, col- lect loose debris for removal. Do not clog waste

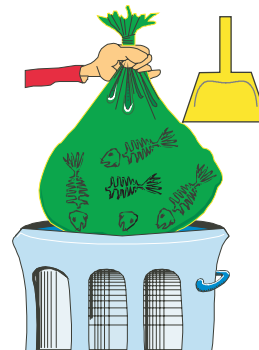

outlet.

STEP 12 – Clean and sanitize according to Health Code requirements.

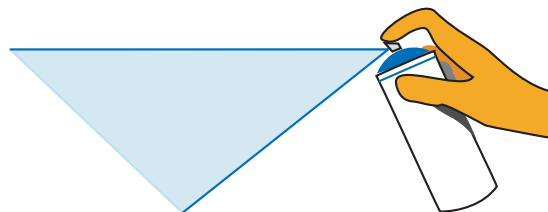
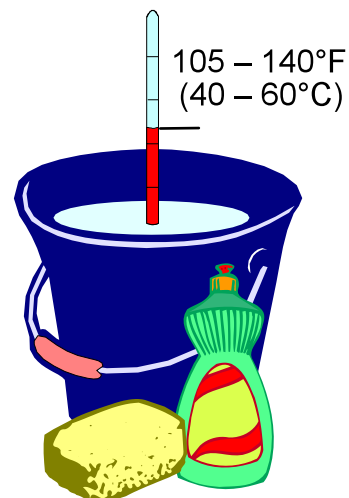

STEP 13 – Reassemble in reverse order.

Turn on power, then refrigera- tion. Make certain merchandiser has cooled to operating temperature before restocking.



MAINTAINING FLUORESCENT LAMPS

Fluorescent lamps should not be allowed to run to failure. If a re-lamp schedule is not in place, the tubes should be inspected for signs of degradation (blackened ends). Degraded or failed tubes should be replaced.

Allowing severely degraded lamps to operate may cause a ballast failure or could expose the lamp holder to excessive heat. Replacing degraded bulbs is more cost effective than replacing ballast and lamp-holders.

Traditional re-lamp programs are 18- to 24-month intervals. In the absence of a re-lamp program, a yearly inspection of the lighting system is recommended.

1. Inspect all lamp sockets and plug-receptacle connections for signs of arcing. Replace any component that shows signs of arcing.
2. Make sure all unused receptacles have their close-off covers securely installed.
3. Make sure proper cleaning procedures are followed. Lights and fans **MUST** be turned off when a case is cleaned and **MUST** be allowed to dry before turning power back on.
4. Do not use a pressure nozzle to clean inside a case.

5-8 MAINTENANCE

Notes:

SERVICE

REPLACING FAN MOTORS AND
BLADES

See cross section for location of evaporator fans. Should it ever be necessary to service or replace the fan motors or blades be certain that the fan blades are re-installed correctly. **THE BLADES MUST BE INSTALLED WITH RAISED EMBOSSED (PART NUMBER ON PLASTIC BLADES) POSITIONED AS INDICATED ON THE PARTS LIST.** (Refer to the case data sheet for each model.)

For access to evaporator fans:

1. Turn off power
2. Remove bottom display pans.
3. **Disconnect fan from wiring harness.**
4. Lift fan plenum out of case. Place on stable work surface.
5. Remove screws holding fan basket to plenum. Fan blade may be removed after fan assembly is removed from plenum.
6. Remove screws holding bottom of motor to fan basket.
7. Replace fan motor and blade in fan basket.
8. Reinstall fan basket in plenum and reinstall plenum in case.
9. Reconnect fan to wiring harness. Turn power on.
10. Verify that motor is working and blade is turning in the correct

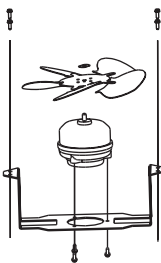
**WARNING**

— **LOCK OUT / TAG OUT** —

To avoid serious injury or death from electrical shock, always disconnect the electrical power at the main disconnect when servicing or replacing any electrical component. This includes, but is not limited to, such items as doors, lights, fans, heaters, and thermostats.

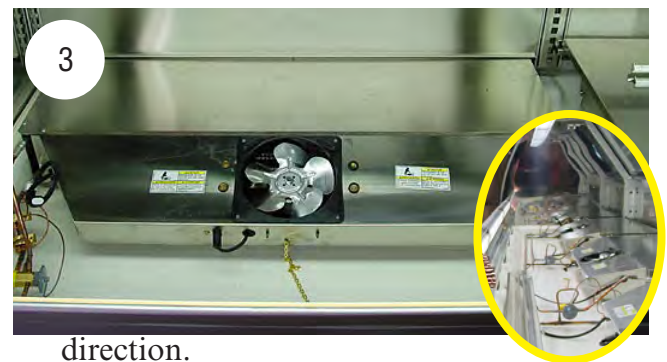

direction.

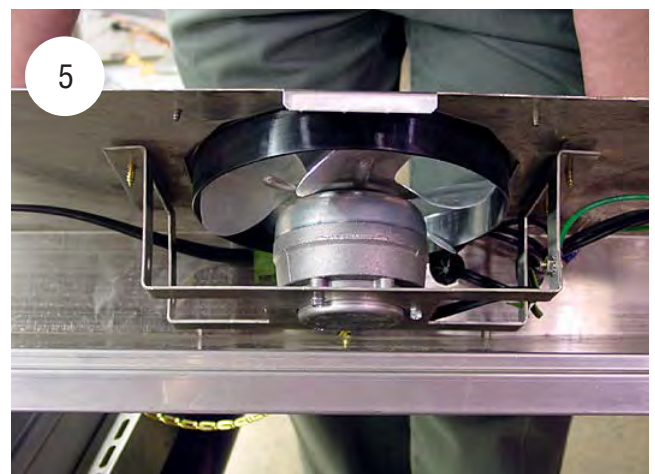

6-2 SERVICE

REPLACING AMBIENT FAN AND AMBIENT HEATER

1. Turn off power.
2. Remove lower front panel.
3. Remove screws holding motor, heater, and grille.
4. Disconnect fan from wiring harness.
5. Disconnect heater from wiring harness.
6. Assemble new fan/heater assembly: See Steps **A-E** this page.
7. Turn power on.
8. Verify that motor is working and blade is turning in the correct direction.
9. Verify that heater is working.
10. Replace lower front panel.

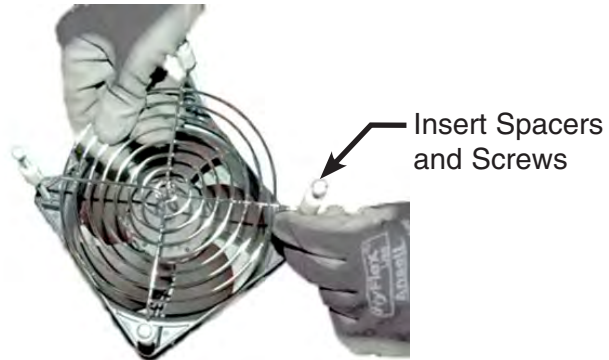
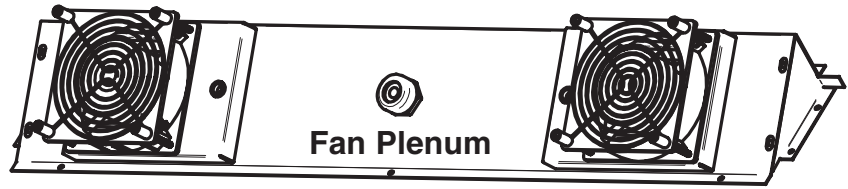

A. Attach grille to fan as shown.



B. Attach Bracket to Fan



C. Connect harness to fan as shown.

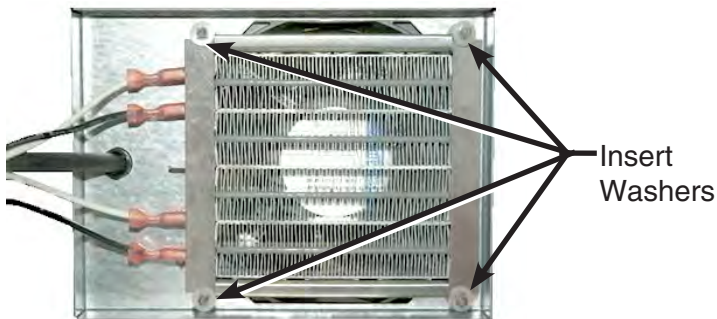

D. Attach heater to harness. Insert heater between fan screws. Insert washers as shown.



E. Attach heater/fan assembly to fan plenum.

REMOVING POLYCARBONATE RAIL LAMP COVERS

The rail covers are removed without tools. From the front of the case, grasp the cover with both hands. Apply pressure as shown in the photo. Pull forward and up as shown in the photo until the back of the cover clears the retainer. Reinstall in reverse order.

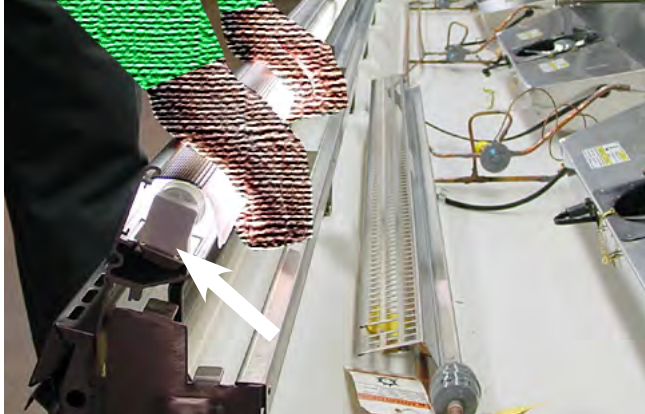

ELECTRICAL SERVICE RECEPTACLES

The receptacles located on the exterior back of the merchandisers are intended for scales and other light duty appliances that are found in meat and delicatessen departments. The receptacles are not intended for large motors.



REPLACING FLUORESCENT LAMPS

Fluorescent lamps are furnished with moisture resistant lamp holders and end caps. Lamps on lighted shelves have plastic shields. Whenever a fluorescent lamp is replaced, be certain to reinstall the plastic shields and end caps.

Inspect all lamp sockets and plug-receptacle connections for signs of arcing. Replace any component that shows signs of arcing.

Make sure all unused receptacles have their close-off covers securely attached.

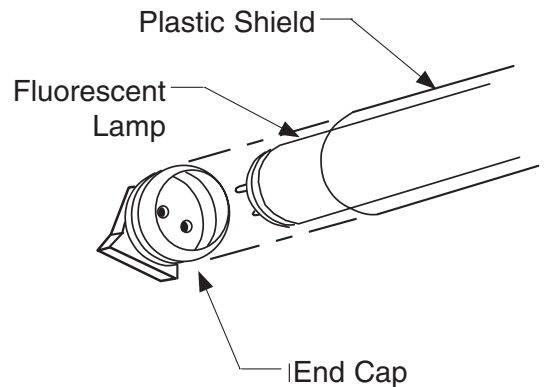

Fluorescent Lamp Disposal: The United States Environmental Protection Agency has information regarding environmentally-safe fluorescent lamp waste management programs. On the Net: EPA Web site: <http://www.epa.gov/osw/hazard/wastetypes/universal/lamps/recycle.htm>

WARNING

Fluorescent lamps contain mercury vapor. Mercury exposure at high levels can harm the brain, heart, kidneys, lungs, and immune system of people of all ages. Do not break or puncture fluorescent lamps. Dispose of, or store, all fluorescent lamps in accordance with Federal (40 CFR 273), State, and local hazardous waste requirements. Refer to <http://www.epa.gov/mercury/about.htm>

⚠ WARNING

— LOCK OUT / TAG OUT —

To avoid serious injury or death from electrical shock, always disconnect the electrical power at the main disconnect when servicing or replacing any electrical component. This includes, but is not limited to, such items as doors, lights, fans, heaters, and thermostats.

REPLACING FLUORESCENT LAMP HOLDERS AND END CAPS

The Hussmann Impact lamp holder is designed to snap into the sheet metal of the case. The lamp holder has a locking ‘nub’ which fits inside the groove of specially designed end caps.

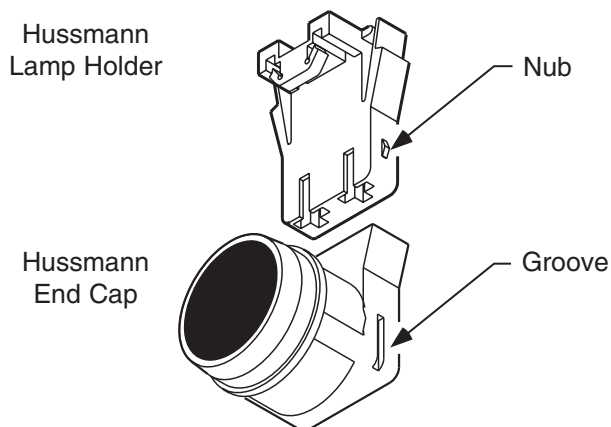

IMPORTANT!

Always replace lamp holders and end caps with Hussmann lamp holders and end caps.

Use of non-Hussmann parts may result in poor electrical contact and short lamp life.

REPLACING ELECTRONIC BALLAST

Lamp Ballast

The lamp ballast are located in the raceway, behind the back lower panel at the left-hand end of the merchandiser (facing rear of case).

NOTE: The lamp switch is located in this panel.

To gain access:

1. Disconnect electrical power.
2. Remove the left lower rear panel.
3. Service or replace ballast as required.
Reassemble items as they were originally installed.
4. Reconnect the electrical power.

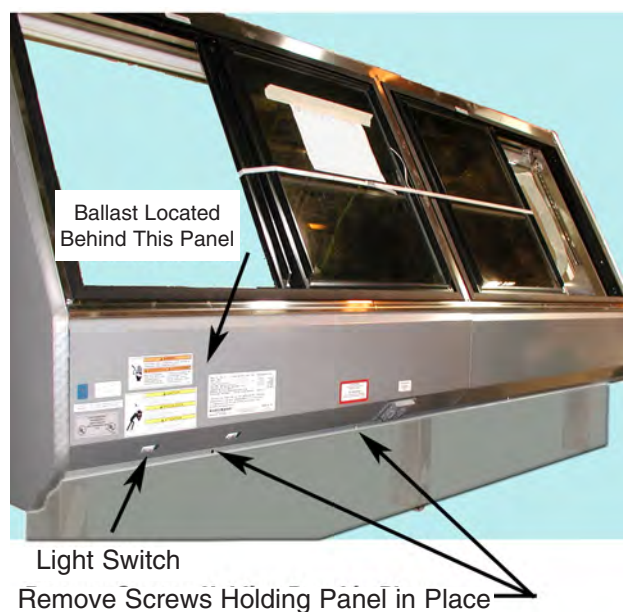

REPLACING LEDs

Locate the LED lamp to be replaced. Always replace with like fixtures. Contact your Hussmann representative for ordering information. All LED fixtures attach using mounting clips and screw.

NOTE:

One power supply can provide power for as many as 10 shelf lights.

Plug the quick-connect plugs into the shelf receptacles at the back of the merchandiser.

Use a tie wrap to contain any excess plug wire. Do not allow wire to lie on product or hang loose.

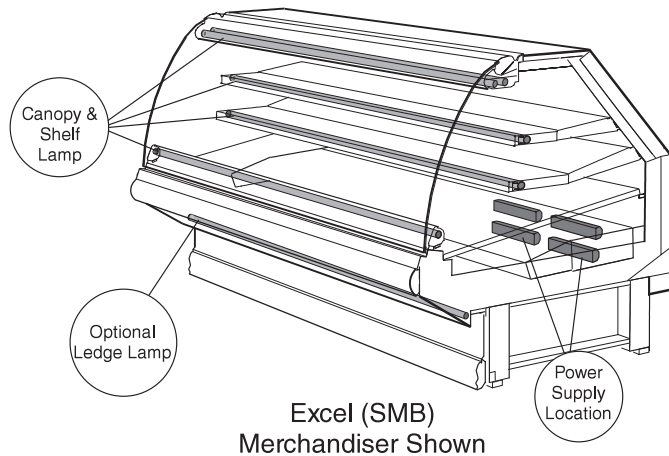
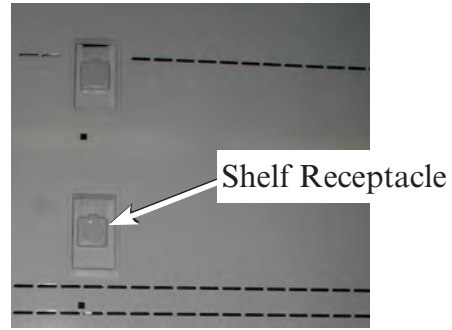

REPLACING POWER SUPPLY(S)

1. Check the Data sheet shipped separately with this case to find the wiring diagram for the lighting. Locate the power supply to be replaced, and remove the leads. Connect the leads to the new power supply. Connect the original load and neutral wires to LED power supply input wires (black and white wires), and secure with approved wiring connectors.
2. Connect the LED power supply output wires to wiring leads.
3. Additional wiring may be needed to connect the power supply to existing wiring in the wireway. Use conductors of proper size and rating.

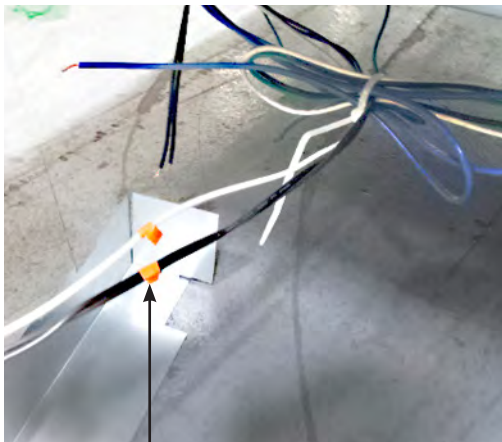

Orange Band

NOTE: Orange or tan band indicates light wiring for Hussmann cases. The photo above shows Hussmann Elite fluorescent shelf wiring. Canopy wiring has a separate outlet for these merchandisers.

TIP: Hussmann factory LED case light wiring is a thicker wire than traditional fluorescent wiring. LED wire colors are black, white and green.

4. The power supply case is grounded. Attach power supply to a ground point in the refrigerated merchandiser, either directly with a screw, or by using a green wire to attach to a remote ground point

DO NOT LEAVE ANY EXPOSED WIRE NUTS OR CONNECTORS.

IMPORTANT

Ensure that all connection points are sealed for damp location using the appropriate method per the NEC or local electrical code.

⚠ WARNING

— LOCK OUT / TAG OUT —

To avoid serious injury or death from electrical shock, always disconnect the electrical power at the main disconnect when servicing or replacing any electrical component. This includes, but is not limited to, such items as doors, lights, fans, heaters, and thermostats.

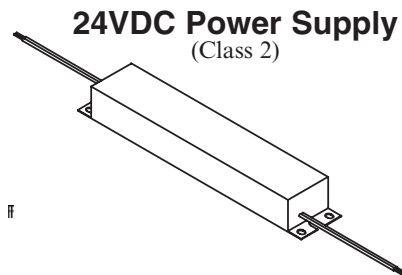

Advance Xitanium 100W 24vdc, LEDINTA0024V41FO or Kaimei Electronic Corp. BAAB1100LE202

Part Number: 0499399 OEM
1 per kit 4481668 Aftermarket

REPLACING CYLINDERS — SINGLE PANE GLASS

When cylinders need to be replaced, the lifting force of the cylinder must be known. The lifting force can be determined by the data printed on the cylinder being replaced.

NOTICE

Cylinder rods must point down so oil will lubricate the rod and seals. Failure to lubricate will severely shorten cylinder life.

Cylinders are a wear item.
They are designed:

- to support the glass when fully open.
- to allow the glass to come down (or close) slowly.

**HAVE YOUR SERVICE CONTRACTOR
REPLACE THE CYLINDERS WHEN REQUIRED.**

CAUTION

CHECK EACH GLASS SECTION MONTHLY to determine if support cylinders are worn and need to be replaced. If the glass does not stay in a raised position, have the cylinders replaced.

Each front curved glass section weighs about 40 lb (18 kg). To prevent glass from falling during installation, use or maintenance, and causing injury to customers or personnel, Hussmann recommends one person hold the glass in a raised position while the other person performs cylinder replacement.

Support the front glass at all times until cylinder is replaced or the glass is lowered.

Once cylinders are removed, front glass will have NO support to maintain it in a raised position.

Raise the glass completely. **Support the full weight of the glass at all times while working on the cylinders.**

Parts Referred to in Illustrations:

A – Gas Spring Pin, 6x18mm (040)

B – Graver $\text{Æ}6$

C – E-ring $\text{Æ}5\text{mm UNI 7434}$

D – Gas Spring HL Stroke 56

E – E-ring Installation Tool

Disassembling Cylinders (refer to illustration)

1. Push out the gas spring pin – A – with the aid of a graver – B – and small hammer (6 oz [150 gram]).

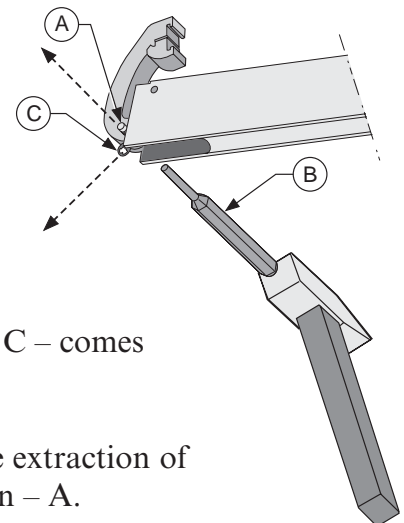

2. The E-ring – C – comes out of its seat.
3. Complete the extraction of the gas spring pin – A.

Assembling Cylinders (refer to illustration)

1. Insert the gas spring – D into the case. Hold the hinge in the ‘open’ position.

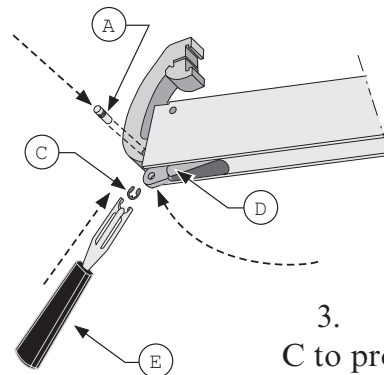

2. Insert the gas spring pin – A into the hole of the hinge and into the gas spring – D.

3. Insert the E-ring C to properly seat the gas spring pin – A with tool – E.

REPLACING GLASS HAND GRIP

The hand grip is fastened to the curved glass as shown below. A 2 inch (51 mm) bead of silicone needs to be placed 3 inches (76 mm) from each end and in the center of the hand grip. The duct tape is placed on the glass to provide a tight fit.

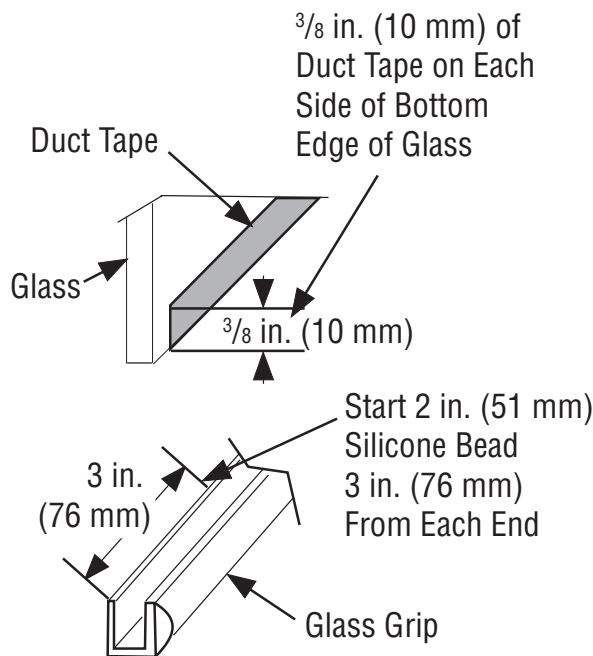

⚠ CAUTION

Each front curved glass section weighs about 40 lb (18 kg). To prevent glass from falling during installation, use or maintenance, and causing injury to customers or personnel, Hussmann recommends one person hold the glass in a raised position while the other person performs adjustments or loosens clamps.

Once set screws are loose, the glass and glass clamp have NO support or retainers. Support front glass at all times until clamps and screws are secure or glass is removed!

Adjust all hinge assemblies on each case at the same time to prevent glass binding and breakage.

REPLACING FRONT GLASS

REQUIRES AT LEAST TWO PEOPLE!

The following procedure is for field replacement of hinged front curved or straight glass.

1. Open glass to its full extension.
2. With glass fully supported, loosen set screw located along the channel in top of glass as shown in the photo at right.

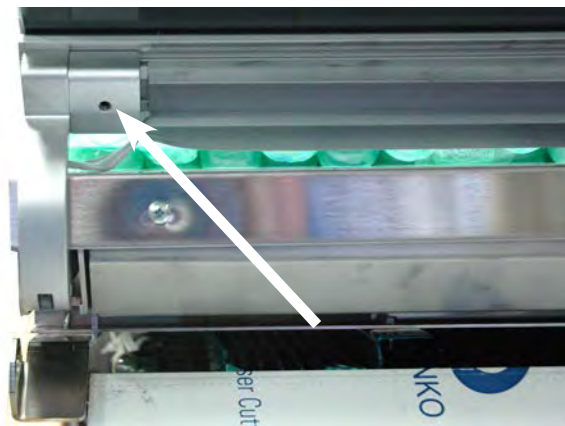

Once set screw are loose, the glass and glass clamp have NO support or retainers. Support the front glass at all times until the glass clamp and set screws are secured, or glass is removed.

3. Remove Glass.
4. Apply gasket to new replacement glass.
5. Position replacement glass in clamps and tighten Allen bolts at each end.

IMPORTANT

When reinstalling glass, be certain that:

- Gasket is on glass evenly.
- Glass is fully seated in clamps.
- When set screws are tightened, glass is firmly held in place by the glass clamps.

Apply a drop of Loctite 242 or equivalent threading locking fluid onto each set screw of the glass clamp assembly. Tighten all screws with a TORX T15 bit.

IMPORTANT: Tighten all glass clamp set screws to 26 inch lbs. Verify bit is in good condition and not worn out. When set screws are tightened, glass is firmly held in place by glass clamps.

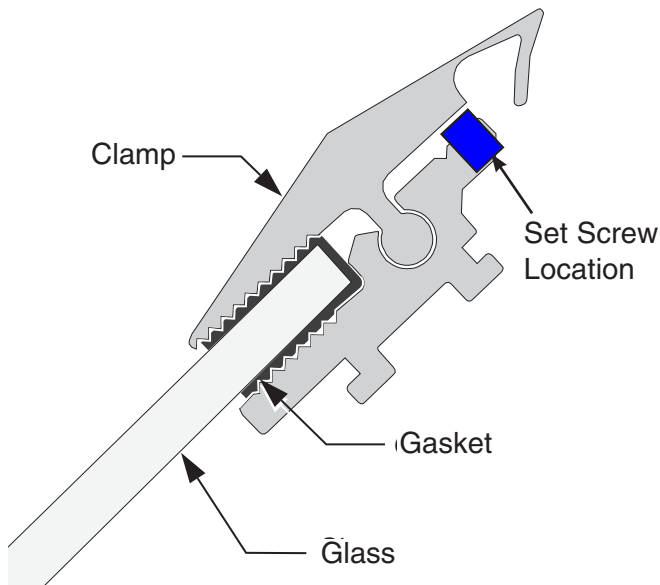

6. Adjust glass horizontally and vertically as described on Page 1-5, *Front Glass Positioning*.

REPLACING DAMAGED DRAIN FITTING

The following procedure is for the field repair of a broken drain fitting.

1. Use a drill with a 2 in. (51 mm) hole saw to drill out the bottom of the drain fitting. Be sure to drill completely through fitting and bottom liner.

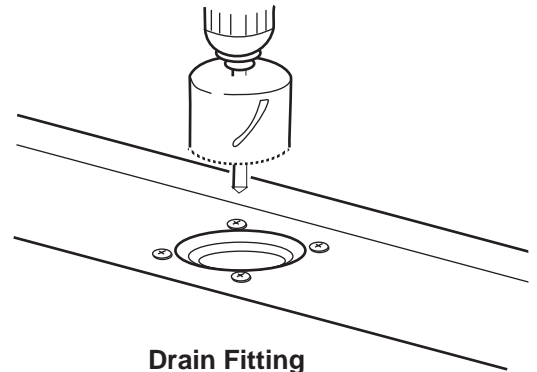

Drain Fitting Viewed from Inside Merchandiser

2. Insert coupling into drain fitting. **Do not apply PVC or ABS pipe sealer to drain fitting, or the drain fitting may become damaged or crack.**
3. Install a PVC adapter on the drip trap. Apply primer-sealer to a stub piece of PVC pipe and insert between coupling and adapter.

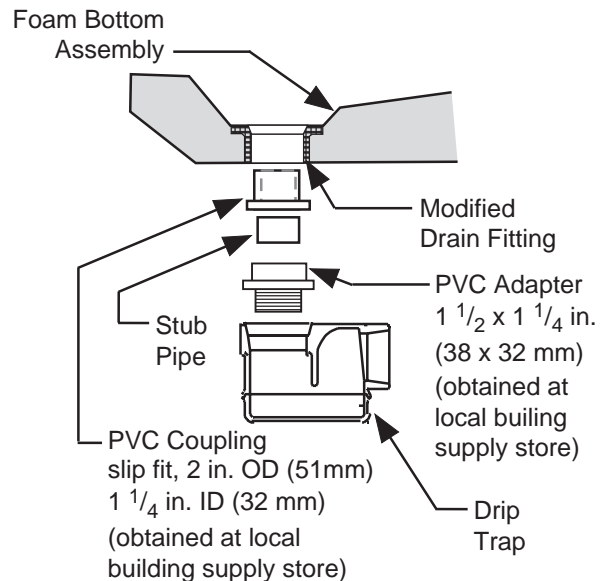

6-10 SERVICE

REPAIRING ALUMINUM COIL

The aluminum coils used in Hussmann merchandisers may be easily repaired in the field. Materials are available from local refrigeration wholesalers.

Hussmann recommends the following solders and technique:

Solders

Aladdin Welding Products Inc.

1300 Burton St., P.O. Box 7188

Grand Rapids, MI 49507

Phone: 1-800-645-3413

Fax: 1-800-645-3414

X-Ergon

1570 E. Northgate, P.O. Box 2102

Irving, TX 75062

Phone: 1-800-527-9916

NOTE:

Hussmann Aluminum melts at 1125°F (607°C)

Aladdin 3-in-1 rod at 732°F (389°C)

X-Ergon Acid core at 455°F (235°C)

WARNING

REFRIGERANT VAPOR IS HAZARDOUS TO YOUR HEALTH AND CAN CAUSE DEATH.

Be sure that any room where you are working is thoroughly ventilated, especially if a leak is suspected.

Avoid breathing refrigerant and lubrication vapor or mist. Exposure may irritate eyes, nose and throat. If accidental system discharge occurs, ventilate work area before resuming service

Refrigeration lines are under pressure and should be depressurized before attempting to make any connections.

Read all safety information regarding the safe handling of refrigerant and refrigerant oil, including the Material Safety Data Sheet. MSDS sheets can be obtained from your refrigerant supplier.

Always wear safety goggles and protective gloves when working with refrigerants. Contact with refrigerant may cause injury. Disconnect hoses with extreme caution! All hoses may contain liquid refrigerant under pressure.

When brazing pipes, be sure to use the insulation blanket shipped with the merchandiser to prevent fire or damage to the plastic case bottom.



HUSSMANN[®]

**To obtain warranty information
or other support, contact your
Hussmann representative.
Please include the model and
serial number of the product.**

Hussmann Corporation, Corporate Headquarters: Bridgeton, Missouri, U.S.A. 63044-2483 01 October 2012

Husmann Corporation

12999 St. Charles Rock Road
Bridgeton, MO 63044-2483
www.husmann.com