

FNGSC-A

Dual Temperature Air-cooled Island Merchandiser

with R-290 Refrigerant

WARNINGS:

If the information in these instructions are not followed exactly, a fire or explosion may result, causing property damage, personal injury or death.

Installation and service must be performed by a qualified installer or service agency.

**READ THE ENTIRE MANUAL BEFORE
INSTALLING OR USING THIS EQUIPMENT.**

The unit uses R-290 gas as the refrigerant. R-290 is flammable and heavier than air. It collects first in low areas but can be circulated by the fans. If propane gas is present or even suspected, do not allow untrained personnel to attempt to find the cause. The propane gas used in the unit has no odor. The lack of smell does not indicate a lack of escaped gas. If a leak is detected, immediately evacuate all persons from the store, and contact the local fire department to advise them that a propane leak has occurred. Do not let any persons back into the store until the qualified service technician has arrived and that technician advises that it is safe to return to the store. No open flames, cigarettes or other possible sources of ignition should be used inside or in the vicinity of the units.

**FAILURE TO ABIDE BY THIS WARNING COULD
RESULT IN AN EXPLOSION, DEATH, INJURY AND
PROPERTY DAMAGE.**

IMPORTANT

Keep in store for future reference!

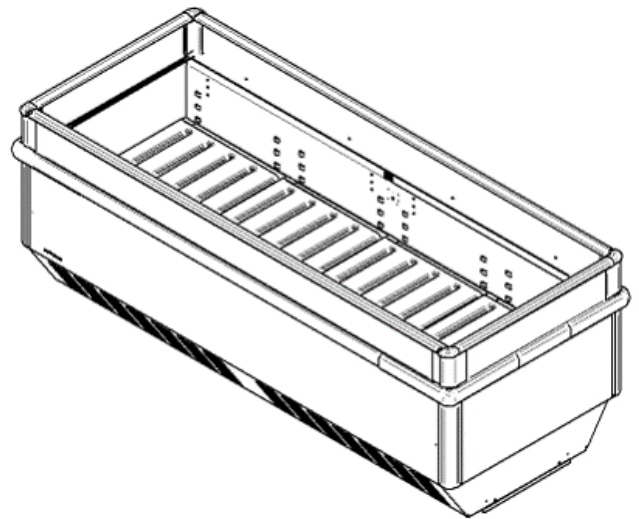

Installation & Operation Manual

P/N 3141959_E

September 2024

Spanish 3141958

French 3206125



BEFORE YOU BEGIN

Read these instructions completely and carefully.

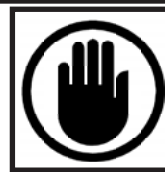

PERSONAL PROTECTION EQUIPMENT (PPE)

Personal Protection Equipment (PPE) is required whenever installing or servicing this equipment. Always wear safety glasses, gloves, protective boots or shoes, long pants, and a long-sleeve shirt as required when installing or servicing this equipment.



1. If the information in these instructions are not followed exactly, a fire or explosion may result, causing property damage, personal injury or death.
2. Installation and service must be performed by a qualified installer or service agency.
3. This unit is designed only for use with R-290 gas as the designated refrigerant.

THE REFRIGERANT LOOP IS SEALED. ONLY A QUALIFIED TECHNICIAN SHOULD ATTEMPT TO SERVICE!

- Propane is flammable and heavier than air.
- It collects first in the low areas but can be circulated by the fans.
- If R-290 is present or even suspected, do not allow untrained personnel to attempt to find the cause.
- The propane gas used in the unit has no odor.
- The lack of smell does not indicate a lack of escaped gas.
- If a leak is detected, immediately evacuate all persons from the store, and contact the local fire department to advise them that a propane leak has occurred.
- Do not let any persons back into the store until the qualified service technician has arrived and that technician advises that it is safe to return to the store.
- A hand-held propane leak detector (“sniffer”) shall be used before any repair and/or maintenance.
- No open flames, cigarettes or other possible sources of ignition should be used inside the building where the units are located until the qualified service technician and/or local fire department determines that all propane has been cleared from the area and from the refrigeration systems.
- Component parts are designed for propane and non-incendive and non-sparking. Component parts shall only be replaced with identical repair parts.

FAILURE TO ABIDE BY THIS WARNING COULD RESULT IN AN EXPLOSION, DEATH, INJURY AND PROPERTY DAMAGE.

ATTENTION

Merchandiser must operate for 24 hours before loading product!

Regularly check case temperatures. Do not break the cold chain. Keep products in cooler or freezer before loading into merchandiser.

These merchandisers are designed to operate at dual temperatures. Only load pre-chilled products in medium temperature settings.

Only load pre-frozen products in low temperature settings.



TABLE OF CONTENTS

<p>ANSI Z535.5 DEFINITIONS v</p> <p>INSTALLATION</p> <p>UL Listing 1-1</p> <p>Federal / State Regulation 1-1</p> <p>Husmann Product Control 1-1</p> <p>Shipping Damage 1-1</p> <p>Location 1-1</p> <p>Self Contained (Location) 1-2</p> <p>Model Description 1-2</p> <p>Unloading 1-2</p> <p>Shipping Skid 1-3</p> <p>Merchandiser Leveling 1-3</p> <p>Serial Plate Location 1-4</p> <p>Refrigeration Unit Access 1-4</p> <p>Sealing Merchandiser to Floor 1-4</p> <p>Self-Contained Refrigeration Equipment Start Up Check List 1-5</p> <p>ELECTRICAL / REFRIGERATION</p> <p>Merchandiser Electrical Data 2-1</p> <p>Field Wiring 2-1</p> <p>Electrical Connections 2-1</p> <p>Electrical Outlet 2-1</p> <p>Refrigeration 2-1</p> <p>Refrigeration System Functionality 2-2</p> <p>Refrigeration System Layout 2-6</p> <p>Replacing Refrigeration System Components 2-9</p> <p>Steps to Recover Refrigerant 2-9</p> <p>Charging 2-10</p> <p>Evaporation Pans 2-11</p> <p>Installing Drip Piping 2-12</p> <p>Drip Piping Lineup Arrangements 2-13</p>	<p>START UP / OPERATION</p> <p>Changing Between Medium & Low Temperature Applications 3-1</p> <p>Controller Operation 3-3</p> <p>LED 3-4</p> <p>KDEPLUS Buttons 3-5</p> <p>Setpoint: Setting and Edit Lock 3-6</p> <p>Display Probes Value 3-6</p> <p>Key-Activated Functions 3-6</p> <p>Typical Sensor Location 3-7</p> <p>Controls and Adjustments 3-10</p> <p>Load Limits 3-11</p> <p>Stocking 3-11</p> <p>Installing FDA/NSF Required Thermometer 3-11</p> <p>MAINTENANCE</p> <p>Care and Cleaning 4-1</p> <p>Removing Scratches from Bumper 4-2</p> <p>Cleaning Under Fan Plenum 4-2</p> <p>Cleaning Discharge Air Honeycomb 4-2</p> <p>Cleaning Stainless Steel Surfaces 4-3</p> <p>Cleaning Coils 4-3</p> <p>Cleaning Evaporation Pan 4-4</p> <p>Self-Contained Refrigeration Equipment Maintenance Check List 4-5</p> <p>SERVICE</p> <p>Replacing Evaporator Motors 5-1</p> <p>Replacing Inverter 5-2</p> <p>Replacing Condenser Motor 5-3</p> <p>Replacing Compressor 5-4</p> <p>Replacing Drain Heater 5-5</p> <p>Replacing Pan Heater 5-6</p> <p>Replacing Solenoid Valves 5-7</p> <p>Inverter Board Diagnostics 5-8</p> <p>Troubleshooting Guide 5-10</p>
--	--

WARRANTY

The safety of our customers and employees is paramount. The precautions and procedures described in this manual are intended as general methods for safe use of this equipment. Please be sure to comply with the precautions described in this manual to protect you and others from possible harm, and follow OSHA standards for safety.

The definitions at right are used to clarify the magnitude and urgency of harm and damage, considering problems arising from misuse. Relative to their potential danger, the definitions are divided into four parts according to ANSI Z535 Series.



This warning does not mean that Hussmann products will cause cancer or reproductive harm, or is in violation of any product-safety standards or requirements. As clarified by the California State government, Proposition 65 can be considered more of a ‘right to know’ law than a pure product safety law. When used as designed, Hussmann believes that our products are not harmful. We provide the Proposition 65 warning to stay in compliance with California State law. It is your responsibility to provide accurate Proposition 65 warning labels to your customers when necessary. For more information on Proposition 65, please visit the California State government website.

REVISION HISTORY:

REVISION E

Updated cover logos.

REVISION D

Revised Steps to Recover Refrigerant

REVISION C



Revised clearance from 30” to 10”.

REVISION B

Updated evaporation Pans, Page 2-8; Updated Controller Start up Section, Page 3-6 to page 3-1; updated parameters and control adjustments, Page 3-8

ORIGINAL ISSUE — 2021

ANSI Z535.5 DEFINITIONS

- 
 • **DANGER** – Indicate[s] a hazardous situation which, if not avoided, will result in death or serious injury.
- 
 • **WARNING** – Indicate[s] a hazardous situation which, if not avoided, could result in death or serious injury.
- 
 • **CAUTION** – Indicate[s] a hazardous situation which, if not avoided, could result in minor or moderate injury.
- **NOTICE** – Not related to personal injury – Indicates[s] situations, which if not avoided, could result in damage to equipment.



WARNING

Excessive ambient conditions may cause condensation and therefore sweating of doors. Facility operators should monitor doors and floor conditions to ensure safety of persons.

All installation and operating instructions concerning the handling, moving, and use of these merchandisers must be carefully followed to avoid either damaging the refrigerant tubing, or increasing the risk of a leak.

Case ventilation openings must be clear of any obstructions. Do not damage the refrigerant circuit.

Always disconnect the electrical power at the main disconnect when servicing or replacing any electrical component. This includes, but is not limited to, such items as fans, heaters, thermostats and lights.

Do not use mechanical devices or other means to accelerate the defrosting process.

Do not use electrical appliances inside the food storage compartments of the case.

INSTALLATION

UL LISTING

These merchandisers are manufactured to meet ANSI/ UL 471 standard requirements for safety. Proper installation is required to maintain the listing.

FEDERAL / STATE REGULATION

These merchandisers at the time they are manufactured, meet all federal and state/provincial regulations. Proper installation is required to ensure these standards are maintained. Near the serial plate, each merchandiser carries a label identifying the environment for which the merchandiser was designed for use.

**ANSI/NSF-7 Type I – Display Refrigerator / Freezer
Intended for 75°F (24°C) / 55% RH Ambient Application**

**ANSI/NSF-7 – Display Refrigerator
Intended for Bulk Produce**

HUSSMANN PRODUCT CONTROL

The serial number and shipping date of all equipment is recorded in Hussmann's files for warranty and replacement part purposes. All correspondence pertaining to warranty or parts ordering must include the serial number of each piece of equipment involved. This is to ensure the customer is provided with the correct parts.

SHIPPING DAMAGE

All equipment should be thoroughly examined for shipping damage before and during unloading. This equipment has been carefully inspected at our factory. Any claim for loss or damage must be made to the carrier. The carrier will provide any necessary inspection reports and/or claim forms.

Apparent Loss or Damage

If there is an obvious loss or damage, it must be noted on the freight bill or express receipt and signed by the carrier's agent; otherwise, carrier may refuse claim. Do not under any circumstances connect a damaged cabinet to the electric circuit. Otherwise, there is the risk of electric shock or refrigerant leakage!

Concealed Loss or Damage

When loss or damage is not apparent until after equipment is uncrated, retain all packing materials and submit a written response to the carrier for inspection within 15 days.

LOCATION

These merchandisers are designed for displaying products in air conditioned stores where temperature is maintained at or below the ANSI / NSF-7 specified level and relative humidity is maintained at or below 55%. Placing refrigerated merchandisers in direct sunlight, near hot tables or near other heat sources could impair their efficiency. Like other merchandisers, these merchandisers are sensitive to air disturbances. Air currents passing around merchandisers will seriously impair their operation. Do NOT allow air conditioning, electric fans, open doors or windows, etc. to create air currents around the merchandiser.

**Recommended operating ambient
temperature is between
65°F (18°C) to 75°F (24°C).
Maximum relative humidity is 55%.**

1-2 INSTALLATION

LOCATION

Product should always be maintained at proper temperature. This means that from the time the product is received, through storage, preparation and display, the temperature of the product must be controlled to maximize the life of the product.

BE SURE TO POSITION SELF CONTAINED MERCHANDISERS PROPERLY.

These models have vented base panels to allow air circulation through the condensing unit.

Allow for a minimum 10" clearance from walls, merchandisers, and any other large objects near the merchandiser's vented base panels (for self contained models). Blocking or restricting air flow will adversely affect performance and may damage the refrigeration system.

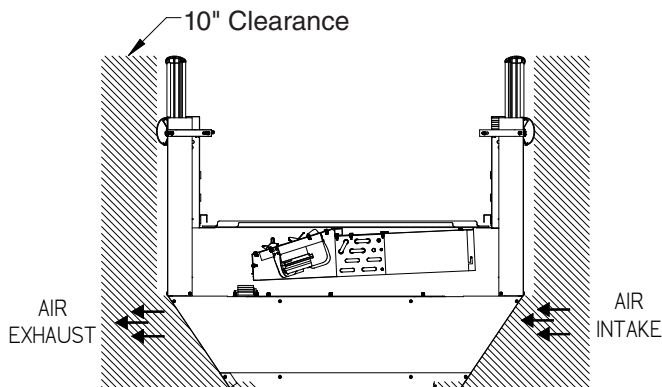

MODEL DESCRIPTION

FNGSC models are island, spot display merchandisers. Each self contained model will have two self-contained units with one dual circuited evaporator.

FNGSC models are designed for dual temperature operation. These models have upper glass on all four sides of the merchandiser.

UNLOADING

Unloading from Trailer:

Lever Bar (also known as a Mule, Johnson Bar, J-bar, Lever Dolly, or Pry Lever)

Move the merchandiser as close as possible to its permanent location and remove all packaging. Check for damage. Remove all separately packed accessories. Improper handling may cause damage to the merchandiser when unloading.

To avoid damage:

1. Do not drag the merchandiser out of the trailer. Use a Johnson bar (mule). Use a forklift or dolly to remove the merchandiser from the trailer.
2. Use caution when moving case to setup location. Use care to not damage refrigeration system. Confirm there are no refrigerant leaks during startup of the case(s).

SHIPPING SKID

Each merchandiser is shipped on a skid to protect the merchandiser's base, and to make positioning the case easier.



Remove the top of the crate and detach walls from each other (if provided). Lift crate from the skid. Unscrew the case from the skid. The fixture can now be lifted off the crate skid. **Lift only at base of skid!** Remove any braces and/or skids attached (blanket wrapped merchandiser may have skids).

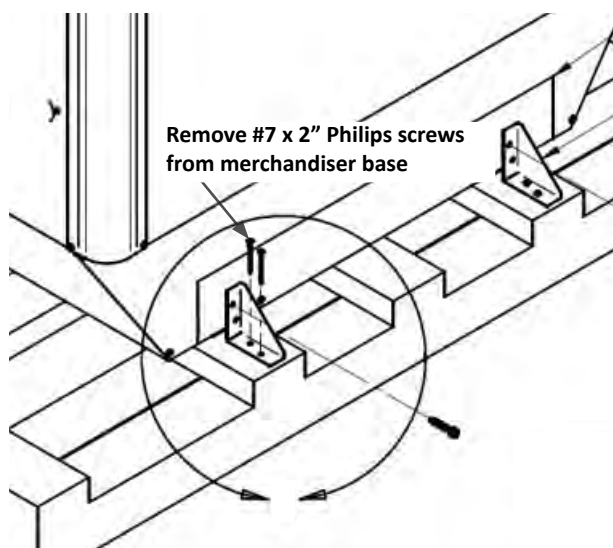

DO NOT LAY MERCHANDISER OVER ON THE FLOOR TO REMOVE SKID.

Once the skid is removed, the merchandiser must be lifted —NOT PUSHED— to reposition. To remove the skid, remove screws attaching skid to the merchandiser.

Check floor where cases are to be set to see if it is a level area. Determine the highest part of the floor.

MERCHANDISER LEVELING

BE SURE TO POSITION MERCHANDISERS PROPERLY. Level the merchandiser by all four corners. Merchandiser(s) must be installed level to ensure proper operation of the refrigeration system and to ensure proper drainage of defrost water.

SERIAL PLATE LOCATION

The serial plate is located on the inside of the merchandiser's display area.

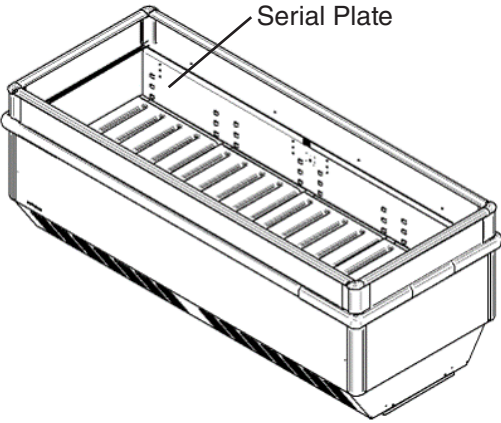

NOTE: Do not allow trim to cover any intake or discharge grilles located in the lower front panel. When the merchandiser is equipped with levelers, sealing to the floor may not be required. Merchandiser may be relocated to another location so that floor can be cleaned.

REFRIGERATION UNIT ACCESS

The lower front panel may be removed by lifting the panel straight upward and over the tabs on which it is hanging. For self contained cases, two screws will have to be removed from either end of the panel. Make sure all electrical wiring is secured, and that there is no damage to the unit from shipment or placement.

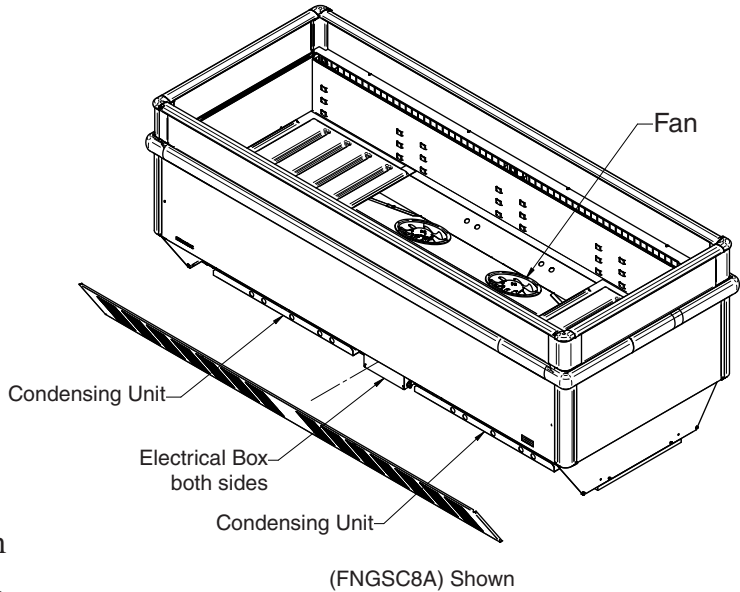

Confirm there are no refrigerant leaks during startup of the case(s). The panel is installed by reversing the above procedure. Ensure merchandiser base is properly installed on case to prevent air circulation problems.

SEALING MERCHANDISER TO FLOOR

If required by local sanitary codes, or if the customer desires, merchandisers may be sealed to the floor. Make sure lower front and rear panels are still able to be removed to service the condensing unit when sealing around the case.

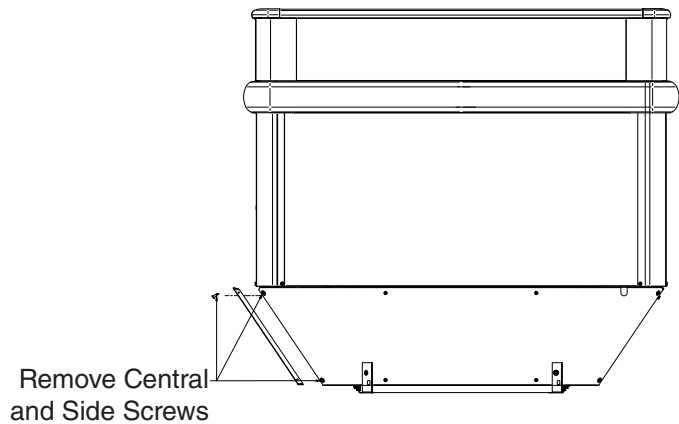

Hussmann Self-Contained Refrigeration Equipment Start Up Check List

Please note that failure to follow this start-up document may void your factory warranty

Step	Startup Activity	Check
1	Locate, read and keep install/operation manual in a safe place for future reference.	<input type="checkbox"/>
2	Examine unit. Confirm there is NO damage or concealed damage.	<input type="checkbox"/>
3	Level the unit, side to side and front to rear.	<input type="checkbox"/>
4	Unit must be run on a dedicated electrical circuit. Do not use adapters.	<input type="checkbox"/>
5	Ensure that the proper electrical requirements for the equipment are supplied.	<input type="checkbox"/>
6	Verify all electrical wiring is secured and clear of any sharp edges or hot lines. Connect plugs (2) to the outlet.	<input type="checkbox"/>
7	Some water should be placed in the drain to close the siphon and prevent formation of ice.	<input type="checkbox"/>
8	Verify the condensate drain line is properly trapped and pitched.	<input type="checkbox"/>
9	Verify all required clearances on the sides and back of unit.	<input type="checkbox"/>
10	Verify there are no air disturbances external to the unit. Heat and air registers, fans, and doors etc.	<input type="checkbox"/>
<p>Advise owner/operator that merchandiser must operate at temperature for 24 hrs prior to loading with product.</p>		

LEGAL DISCLAIMER:

Hussmann shall not be liable for any repair or replacements made without the written consent of Hussmann, or when the product is installed or operated in a manner contrary to the printed instructions covering installation and service which accompanied such product.

1-6 INSTALLATION

NOTES:

ELECTRICAL / REFRIGERATION

MERCHANDISER ELECTRICAL DATA

Refer to the technical data sheets and merchandiser serial plate for electrical information.

FIELD WIRING

Field wiring must be sized for component amperes stamped on the serial plate. Actual ampere draw may be less than specified.

ALWAYS CHECK THE SERIAL PLATE FOR COMPONENT AMPERES

ELECTRICAL CONNECTIONS

All wiring must be in compliance with NEC and local codes.

ELECTRICAL OUTLET

Before the merchandiser is connected to any wall circuit, use a voltmeter to check that the outlet is at 100% of the rated voltage. The wall circuit must be dedicated for the merchandiser. Failure to do so voids the warranty. Do not use an extension cord. Never plug in more than one merchandiser per electrical circuit.

- Always use a dedicated circuit with the amperage stated on the unit.
- Plug into an outlet designed for the plug.
- Do not overload the circuit
- Do not use long or thin extension cords. Never use adapters.
- If in doubt, call an electrician.



NEMA 5-20P
Plug

Self-contained models have factory-installed power cords attached at the electrical box. If a power cord is damaged, it must be replaced by personnel qualified for this task to prevent hazardous situations. FNGSC4 and FNGSC6 have 1 power cord. FNGSC8A have 2 power cords.



WARNING

Case models with two power cords must be plugged in at all times to operate the case.



WARNING

Merchandiser must be grounded.
Do not remove the power supply cord ground.



CAUTION

Risk of Electric Shock. If cord(s) or plug(s) becomes damaged, replace only with a cord and plug of the same type.

REFRIGERATION

Each self contained model will have two self-contained units with one dual circuited evaporator. The correct type of refrigerant will be stamped on each merchandiser's serial plate. The merchandiser refrigeration piping is leak tested.

REFRIGERATION SYSTEM FUNCTIONALITY

These cases can be used for medium or low temperature applications and comply with NSF 7 for medium temperature applications and frozen food. FNGSC-A models are self-contained and have a controller that automates the refrigeration cycle and the defrost cycle.

During refrigeration mode, the discharge line solenoid valves (RSV1, RSV2) are energized and held open, allowing the gas to flow through each condenser.

Once the refrigerant is in a liquid, a capillary tube is used as an expansion device that feeds each evaporator. The darker arrows and lines (left side) show the refrigerant direction through circuit #1, and the lighter arrows and lines (right side) show the refrigerant direction of circuit #2.

During refrigeration mode, hot gas solenoid valves, (HGSV1, HGSV2) are deenergized and (closed).

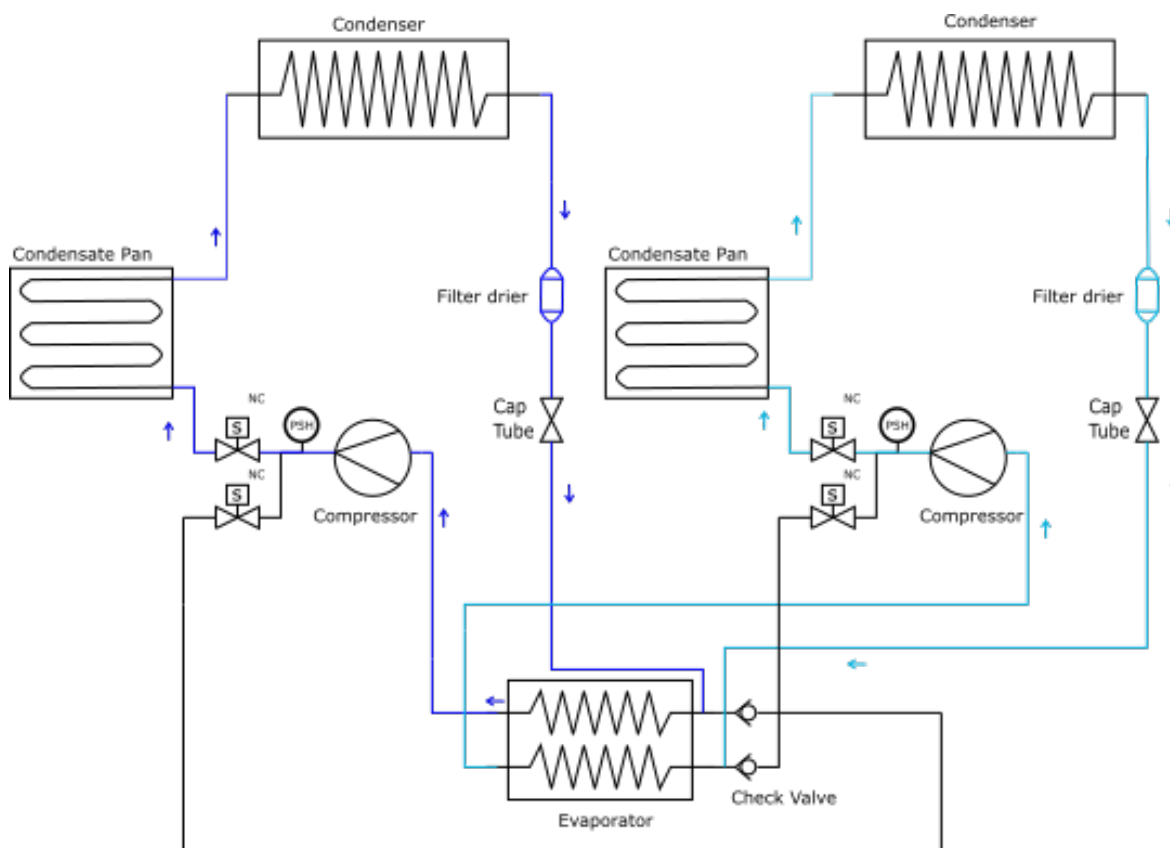

System Diagram— Refrigeration Mode (FNGSC8A)

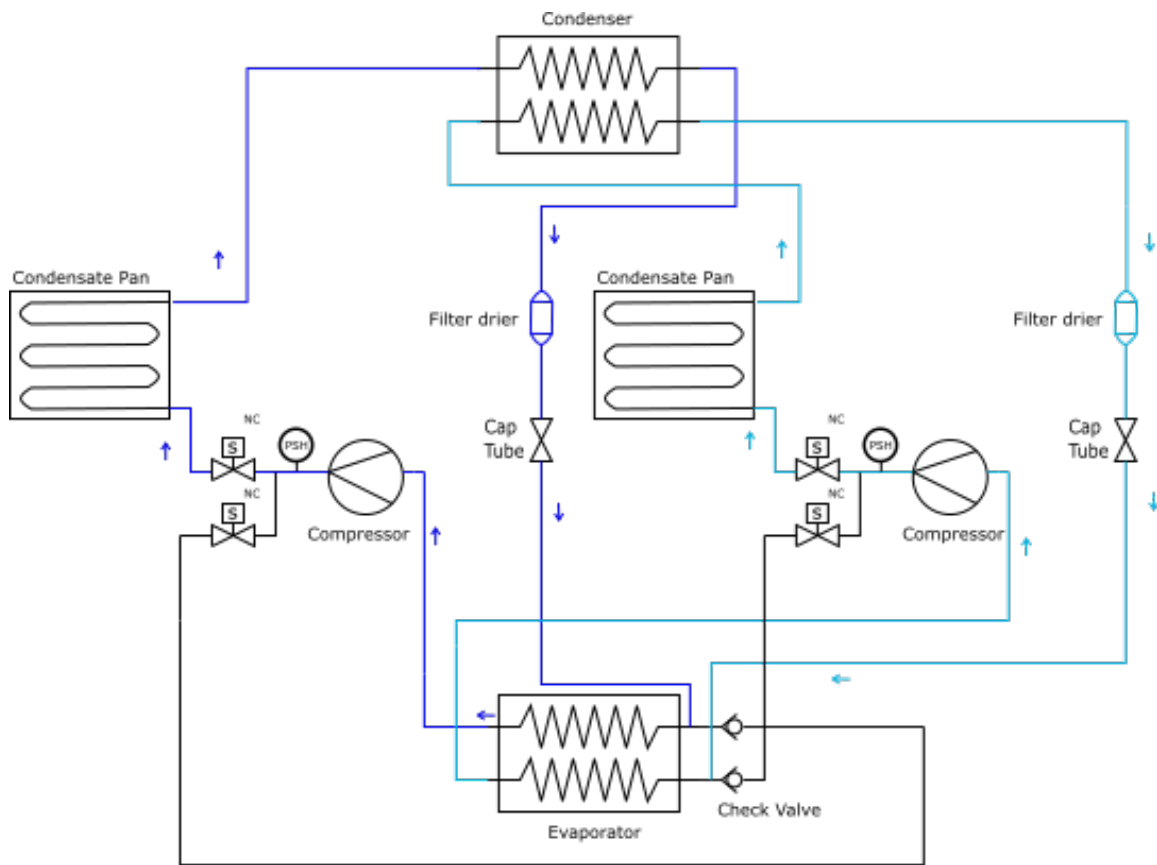

System Diagram— Refrigeration Mode (FNGSC6A)

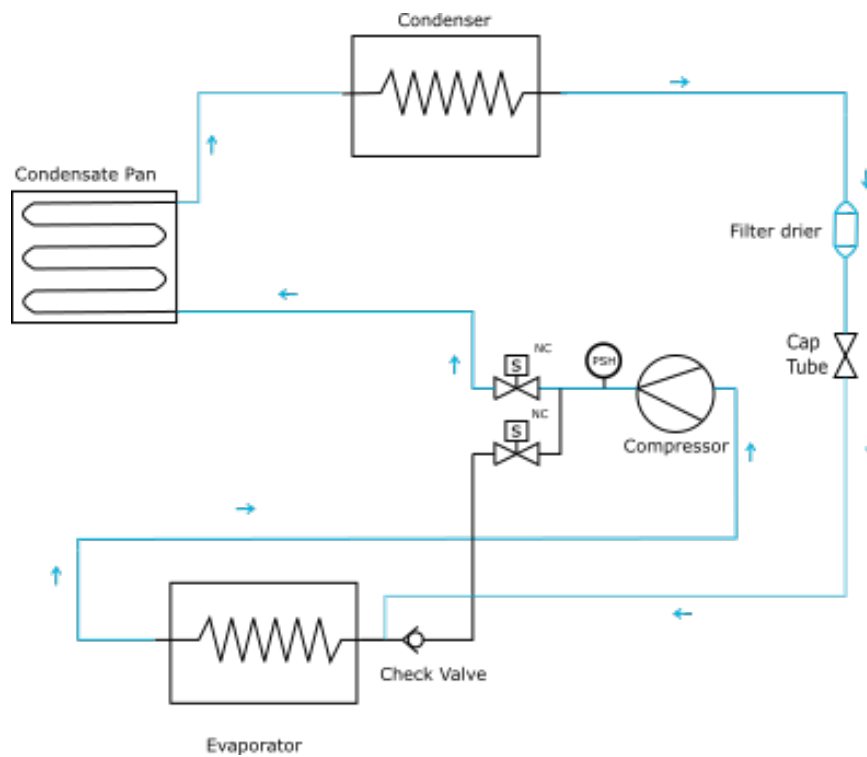

System Diagram— Refrigeration Mode (FNGSC4A)

**REFRIGERATION SYSTEM
FUNCTIONALITY (Continued)**

During defrost mode, the defrost solenoid valves (HGSV1 and HGSV2) are energized and held open allowing the gas to be redirected through each evaporator inlet. The evaporator is split and circuited for 2 refrigeration circuits.

Defrost cycle is temperature-terminated with a failsafe that is 45 minutes. Normally only 3 defrost per day are required.

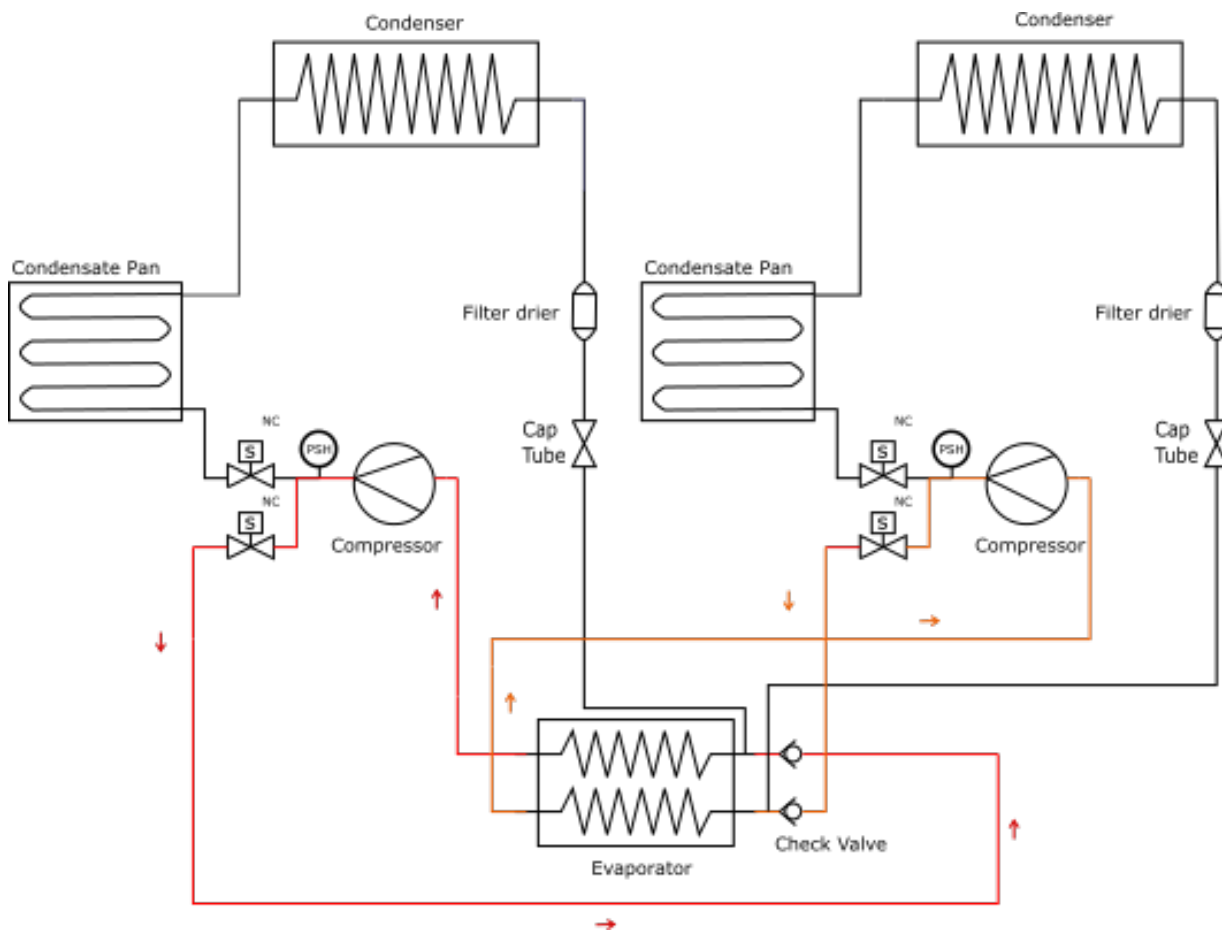

System Diagram – Defrost Mode – Hot Gas Bypass (FNGSC8A)

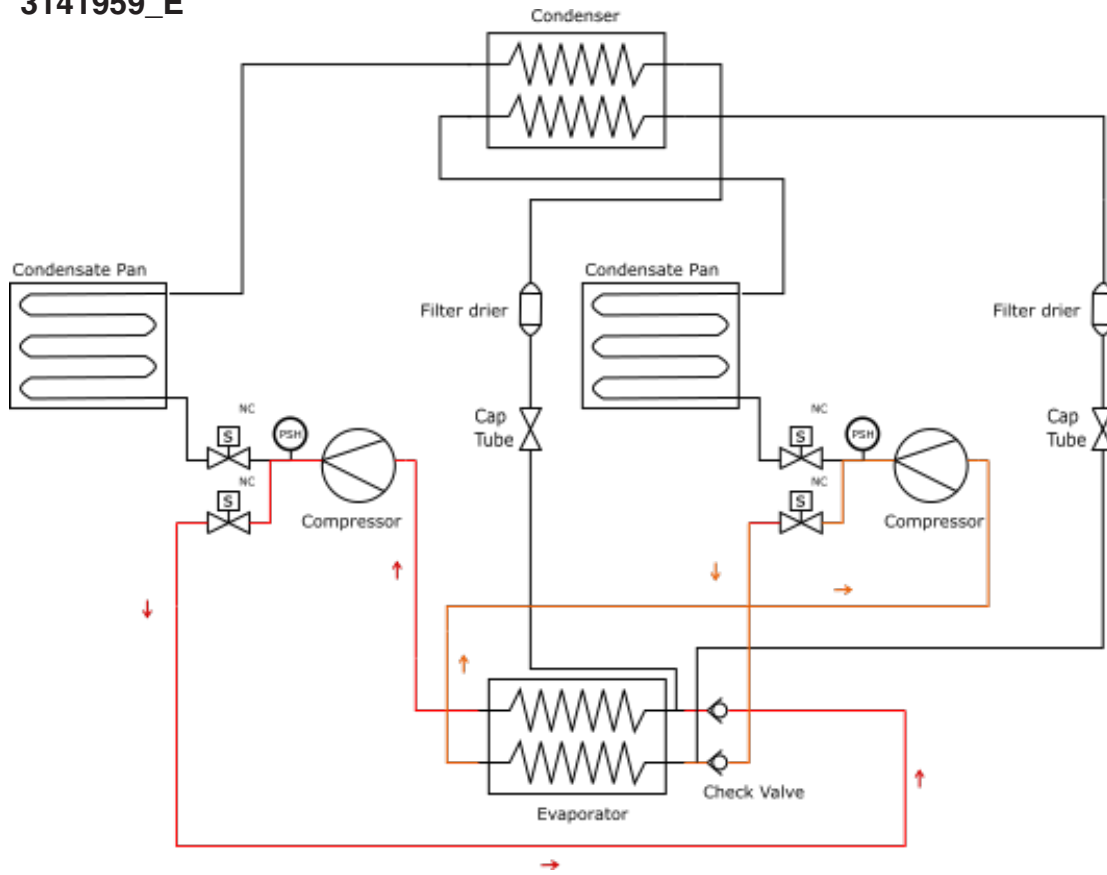

System Diagram – Defrost Mode – Hot Gas Bypass (FNGSC6A)

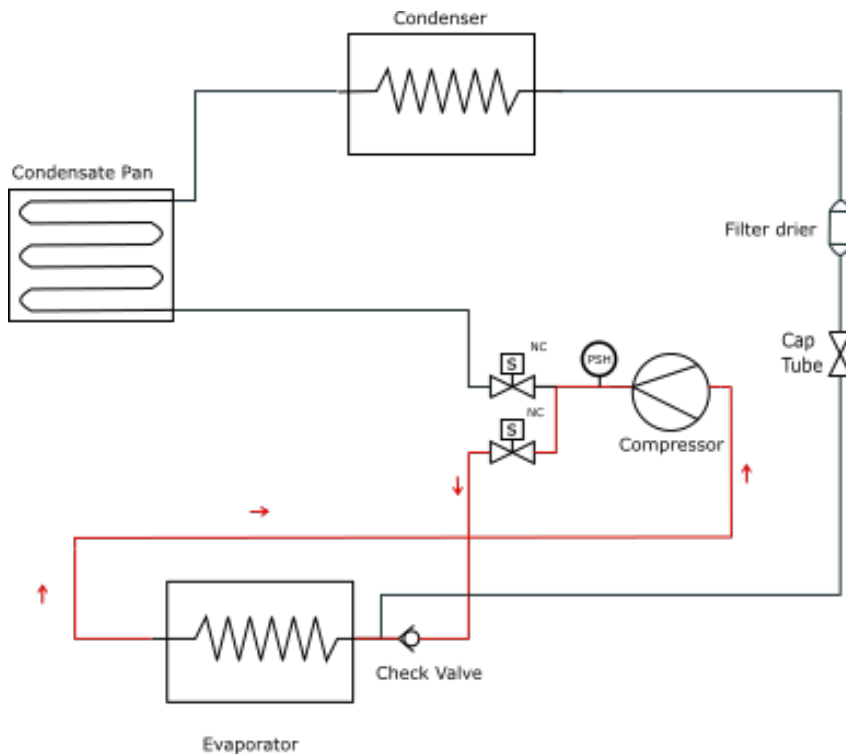

System Diagram – Defrost Mode – Hot Gas Bypass (FNGSC4A)

REFRIGERATION SYSTEM LAYOUT

Product must be pre-frozen for low temp applications. For medium temperature applications products must be pre-chilled. The evaporator is dual circuited. Circuit 1 is the bottom section and Circuit 2 is the top section. In Figure B, lefthand circuit is shown.

The discharge line runs through the evaporation pan to increase the water temperature, located in the top level of the evaporation pan. At the same time, refrigerant temperature drops, increasing system capacity.

The flow is described as the following:

Cap tube is feeding the bottom section of the coil. Once the refrigerant passes through the evaporator, refrigerant goes out to the suction line to the compressor.

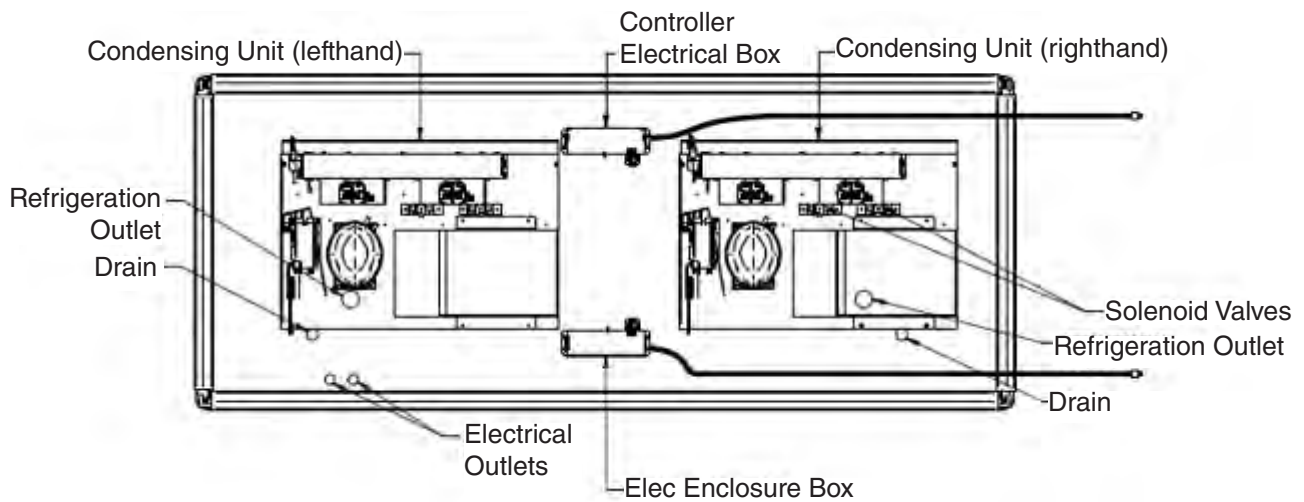

Machine Compartment Layout

(FNGSC8A shown)

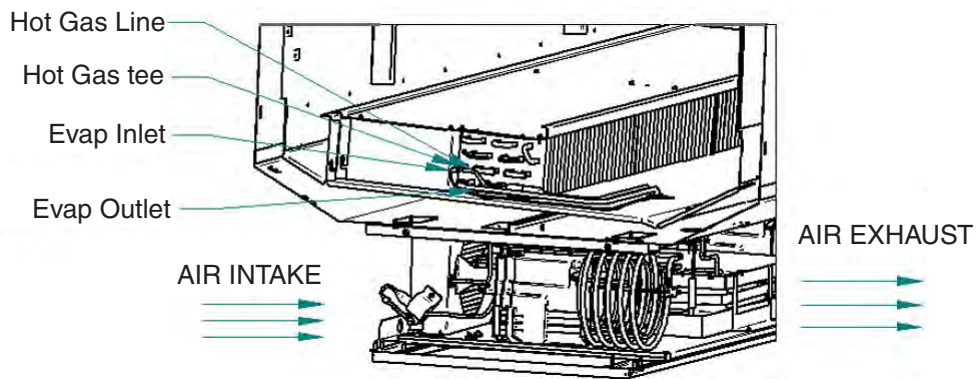

Refrigeration Circuit #1 (left side)

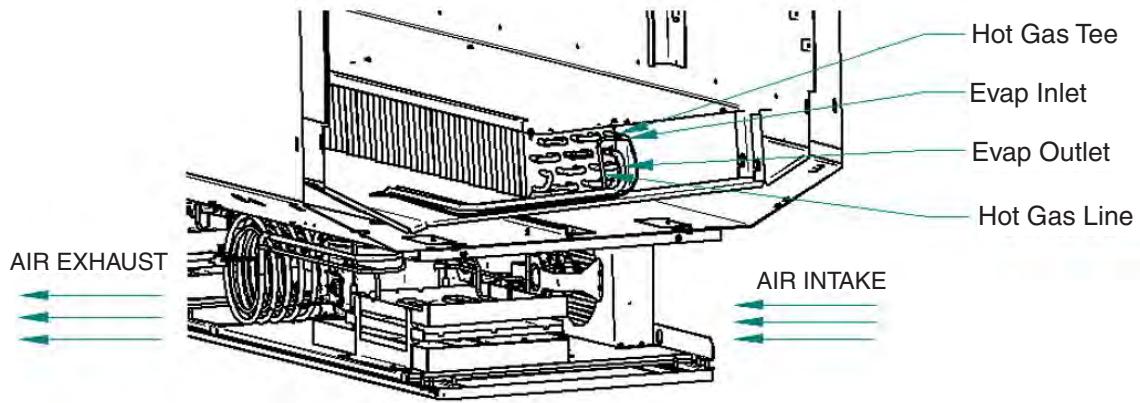

Refrigeration Circuit #2 (right side)

Refrigeration Circuit #2 - Refrigerant flow: Cap tube is feeding the top section of the coil. Once the refrigerant passes through the evaporator, refrigerant goes out to the suction line to the compressor.

Before Beginning Any Service or Repair:

Use a hand-held propane leak detector (“sniffer”) to ensure no propane is present in the immediate area, the inside of the display case and the inside of the refrigeration system. R-290 is an odorless refrigerant. Keep the area clear of all customers and non-essential or unauthorized personnel.

Verify that all repair parts are identical models to the ones they are replacing. Do not substitute parts such as motors, switches, relays, heaters, compressors, power supplies or solenoids. Failure to do so can result in an explosion, death, injury and property damage. Parts used on hydrocarbon cases must meet specific UL certification for non-incendive or non-sparking components. Use only Hussmann approved parts approved through the Hussmann Performance Parts Website:
<https://parts.hussmann.com/>

Brazing must not begin before all propane has been cleared from the immediate area — the inside of the displays case and the inside of the refrigeration system.

⚠ WARNING

Only Hussmann or factory trained technicians should service or repair this R-290 (propane) equipment.

Failure to follow instructions can result in an explosion, death, injury and property damage.

⚠ WARNING

This refrigeration system uses hot gas defrost and incorporates a Normal Closed Solenoid. In order to remove all the refrigerant for service, the valve must be held open while the refrigerant is being evacuated. Failure to remove all the refrigerant can cause a fire or explosion.

⚠ WARNING

Make sure the system is purged through all access ports (Red marked). Components should be cut out (tubing cutters) as opposed to using a torch.

⚠ WARNING

Refrigeration lines are under pressure. Refrigerant must be recovered before attempting any connection or repair.

<p>If a leak is detected, follow store safety procedures. It is the store's responsibility to have a written safety procedure in place. The safety procedure must comply with all applicable codes such as local fire department's codes.</p> <p>At minimum, the following actions are required:</p> <ul style="list-style-type: none">• Immediately evacuate all persons from the store, and contact the local fire department to advise them that a propane leak has occurred.• Call Hussmann and/or a qualified service agent and inform them that a propane sensor has detected the presence of propane.• Do not let any persons back into the store until the qualified service technician has arrived and that technician advises that it is safe to return to the store.	<ul style="list-style-type: none">• The propane gas used in the unit has no odor. The lack of smell does not indicate a lack of escaped gas.• A hand-held propane leak detector ("sniffer") should be used before any repair and/or maintenance is attempted. All repair parts must be identical models to the ones they are replacing.• No open flames, cigarettes or other possible sources of ignition should be used inside the building where the units are located until the qualified service technician and/or local fire department determines that all propane has been cleared from the area and from the refrigeration systems.
---	---

REPLACING REFRIGERATION SYSTEM COMPONENTS



DANGER

Only Hussmann service technicians or technicians qualified to handle R-290 (propane) refrigerant should service or repair this R-290 (propane) equipment. Failure to follow instructions can result in an explosion, death, injury and property damage.

STEPS TO RECOVER REFRIGERANT

1. Make sure you are in a well ventilated area before making any service or repair to the refrigeration system.
2. Disconnect all power sources from the system. Some systems may have more than one plug or power supply.
3. Tap system with line tap valves, attaching gauges to the high and low sides of the system.

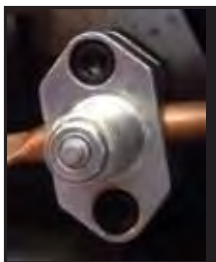

**refrigeration
line tapping
valve**

4. Ensure that the solenoid valves were open to correct evacuation. Use recommended tool (solenoid valve magnet).

Place solenoid magnet over enclosing tube which creates a magnetic field to lift the plunger and stem assembly. This is strongly recommended during refrigerant recovery and evacuation process.

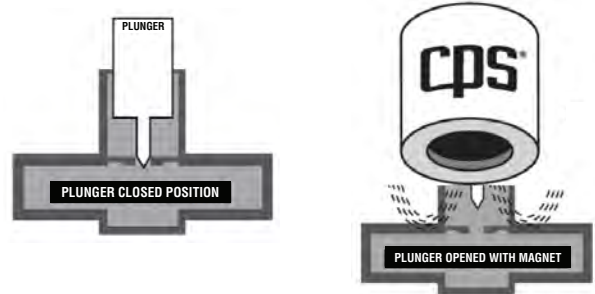

Recommended suppliers for the use of solenoid valve magnet as a field tool to manually operate solenoid valve:

- JB
 - 2. Yellow Jacket
 - 3. CPS
5. Connect hose to an evacuated recovery tank. Open refrigeration gauges and recovery tank.
 6. With the suction valve in vacuum, the refrigerant will be recovered into the recovery tank.
 7. Once recovered, close the tank valve and remove the gauge from the tank and connect nitrogen tank to the system to purge it with nitrogen.
 8. Pull vacuum to a minimum of 200 microns or lower.



CHARGING

A calibrated scale with +/-2 gram accuracy must be used to charge the system. The charge amount is shown on the serial plate. Only R-290 grade refrigerant can be used. Standard propane does not meet the purity/moisture content of R-290, and therefore cannot be used to charge cases.

No gas charge adjustments are allowed. When connecting hoses between the refrigeration system, manifold gauges, and refrigerant cylinder, ensure that the connections are secure and there are no potential sources of ignition nearby. Ensure that contamination of different refrigerants does not occur when using charging equipment.

⚠ WARNING
— LOCK OUT / TAG OUT —
To avoid serious injury or death from electrical shock, always disconnect the electrical power at the main disconnect when servicing or replacing any electrical component. This includes, but is not limited to, such items as doors, lights, fans, heaters, and thermostats.

Use dedicated hoses to service R-290 (propane) refrigeration systems. Hoses or lines should be as short as possible to minimize the amount of refrigerant contained in them.

Ensure that the refrigeration system is properly grounded prior to charging the system with refrigerant, to avoid the potential for static build-up.

⚠ WARNING
Component parts shall be replaced with like components, and servicing shall be done by factory authorized service personnel only, so as to minimize the risk of possible ignition due to incorrect parts or improper service.

Extreme care must be taken not to overfill the refrigeration system. After charging, carefully disconnect the hoses, attempting to minimize the quantity of refrigerant released. Further leak check the service ports, hoses, refrigerant tanks. The service ports shall be checked for leaks using a hydrocarbon leak detector with a sensitivity of 3 grams/year (0.106 Oz/year) leak rate.

Thoroughly leak check the service ports. If no leak is present, use a pinch-off tool to close the ends of the service tubes before brazing them shut. Remove all service ports. If a Schrader valve is used on the compressor service tube, it must be removed and the previous steps followed in order to braze the service tube shut.



EVAPORATION PANS

Make sure the water level is similar in both pans. During defrost cycle or off-time when the compressor reaches setpoint, the water from the evaporator goes to each evaporation pan.



NOTE:

All lower base panels must be in place when the refrigerator is operating. If not, airflow from the condenser will be directed over the evaporator pan and defrost water in the pan may overflow.



INSTALLING DRIP PIPING
(units with a floor drain)

Poorly or improperly installed drip pipes can seriously interfere with the merchandiser’s operation and result in costly maintenance and product losses.

Optional drip pipe arrangements are shown on the next page. Assemble the components using PVC specific threaded pipe sealer according to the manufacturer’s direction.



4. Avoid long runs of drip piping. Long runs make it impossible to provide the pitch necessary for good drainage.
5. Ensure that drip piping is supported to relieve any stress on drip pipe connectors and drain hub.
 - a. Drip piping **MUST** be supported 24 inches from drain hub tee.

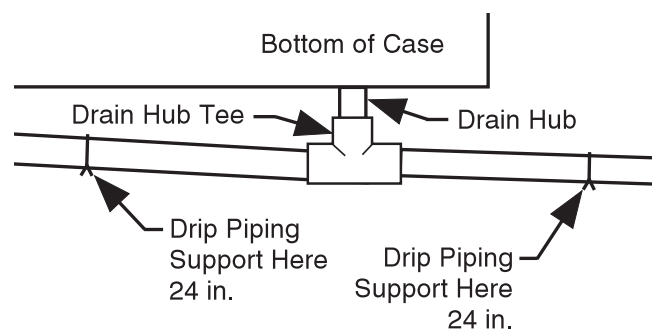

Please follow the recommendations listed below when installing drip pipes to ensure proper installation.

1. Never use drip piping smaller than the nominal diameter of the pipe or water seal supplied with the merchandiser.
2. When connecting drip piping, the *water seal* must be used as part of the drip piping to prevent air leakage or insect entrance. Never use two water seals in series in any one drip pipe. **DOUBLE WATER SEALS IN SERIES WILL CAUSE AN AIR LOCK AND PREVENT DRAINING.**
3. Pitch the drip piping in the direction of flow. **There should be a minimum pitch of 1/4 in. per ft (20 mm per 1 m).**

6. Provide a suitable air break between flood rim of the floor drain and outlet of drip pipe. To meet code requirements, it may be necessary to install a field-supplied drip pipe reducer. An alternative is to cut the last section of drip pipe at an angle.



7. Prevent drip pipes from freezing:
 - a. Do NOT install drip pipes in contact with uninsulated suction lines. Suction lines should be installed with a nonabsorbent insulation material.
 - b. Where drip pipes are located in dead air spaces, such as between merchandisers or between a merchandiser and a store wall, provide means to prevent freezing.

DRIP PIPING LINEUP ARRANGEMENTS

The following illustrations below show typical arrangements for installing drip pipes for a lineup of merchandisers. Illustrations are for reference only. Piping may vary with location and access to hub drain(s). Each merchandiser waste outlet must be individually piped to a hub drain if $\frac{1}{4}$ in. drip piping pitch cannot be maintained.

NOTE: No more than two merchandisers are to be piped per water seal. Do not install water seal between two merchandiser waste outlets that are piped together. **Double water seals in series will cause an air lock and prevent drainage.**

Optional Excel Drip Piping Arrangements

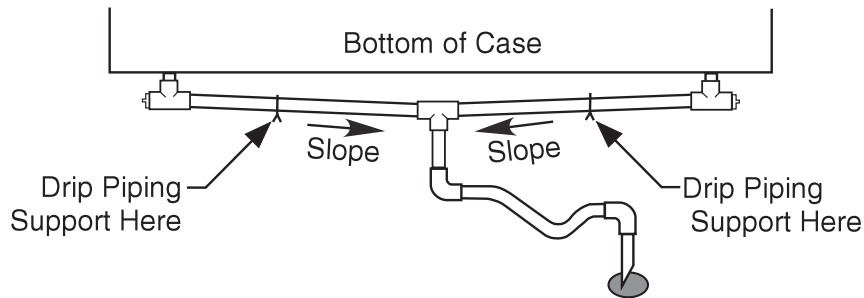

IT IS THE INSTALLING CONTRACTOR'S RESPONSIBILITY TO PROVIDE SUITABLE DRAINAGE.

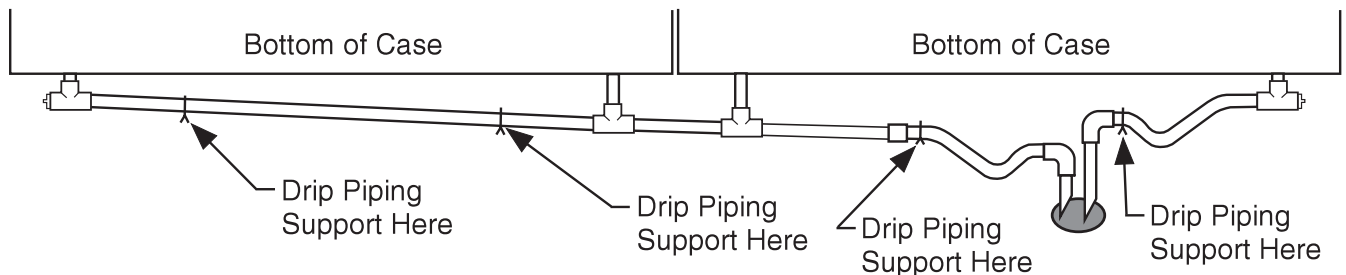

One Water Seal per Run of Drip Pipe
Always Slope Toward Floor Drain

START UP / OPERATION

CHANGING BETWEEN MEDIUM & LOW TEMPERATURE APPLICATIONS

The case is factory pre-programmed with 2 sets of controller settings. One application is low temperature, which is for frozen food. The second application is medium temperature. The case is default programmed with low temperature setting from the factory.

Perform the following steps:

1. Remove the machine compartment cover to access the controller box as shown in Figure 1.
2. Identify the controller power switch location. See Figure 1. This switch feeds voltage to the controller
3. Flip the main switch to “OFF”, then back to the “ON” position.
 - Controller display will start blinking (Figure 2).
4. Then, press and hold the **set** button (Item #4 in Figure 3).
 - This step needs to be done in no more than 3 seconds, or the process will fail.
 - “AP1” is the medium temperature application settings. “AP2” is the low temperature application settings.
5. Navigate in the applications (AP1 - AP8) by using **UP** or **DOWN** buttons (Figure 3).
6. Select the desired application by pressing **set**, or cancel the operation by pressing the **POWER** key or by time out.
 - The word “run” will appear on the display screen (Figure 4).
 - If operation is successful, the display will show “YES” (Figure 5), if not, it will show “NO”.
 - After that, display will start blinking for a few seconds, which means operation has completed successfully.

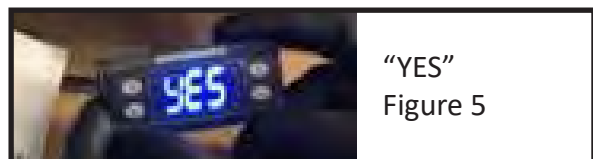
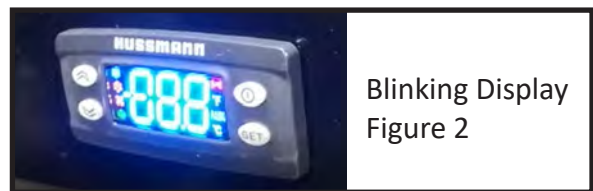
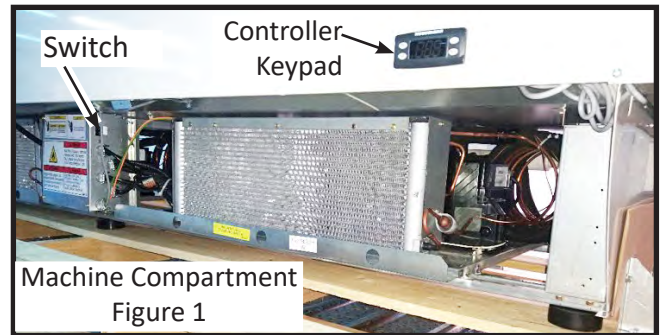

Once the merchandiser is running under the desired application (MT or LT), there will be a defrost cycle performed (Green snowflake symbol).

After coming out from defrost cycle, the system goes to refrigeration mode showing the Blue snowflake on the display. (Continued on next page.)

3-2 **STARTUP / OPERATION**

Perform the following steps:

When the controller display shows the refrigeration symbol, (Blue snowflake) and “dEF” at the same time, the system is in the pull-down stage after ending the defrost cycle.

This “dEF” lasts until the set point is achieved. Once this happens, the discharge air temperature will appear in the display. If for some reason the system is not able to achieve the defined set point, the “dEF” message will last 40 minutes.



Figure A



Figure B

CONTROLLER OPERATION

The electronic controller is located in the cassette compartment.



Controller Electrical Box

The controller comes factory set, and is ready for use. The front grille must be removed in order to access this control. When removing the grille for this operation or for condenser cleaning, care must be taken not to damage the display interface cable. It may be unplugged during this task.

1. Plug the merchandiser plug into its receptacle.
 - a. The controller display will illuminate.
 - b. The interior light will illuminate.

2. After the control preprogrammed time delay of up to 6 minutes, the compressor and evaporator fan(s) will start if the control is calling for cooling.

3. The control will cycle the compressor but may also cycle evaporator fan(s) on and off determined by the setpoint and differential temperatures.

- a. The setpoint is the adjustable preprogrammed temperature.
- b. The differential is the non-adjustable pre-programmed temperature.
- c. The control is designed to read and display a cabinet temperature not a product temperature.

This cabinet temperature may reflect the refrigeration cycle of the setpoint and it's differential. The most accurate temperature on a cabinets operation is to verify the product temperature.

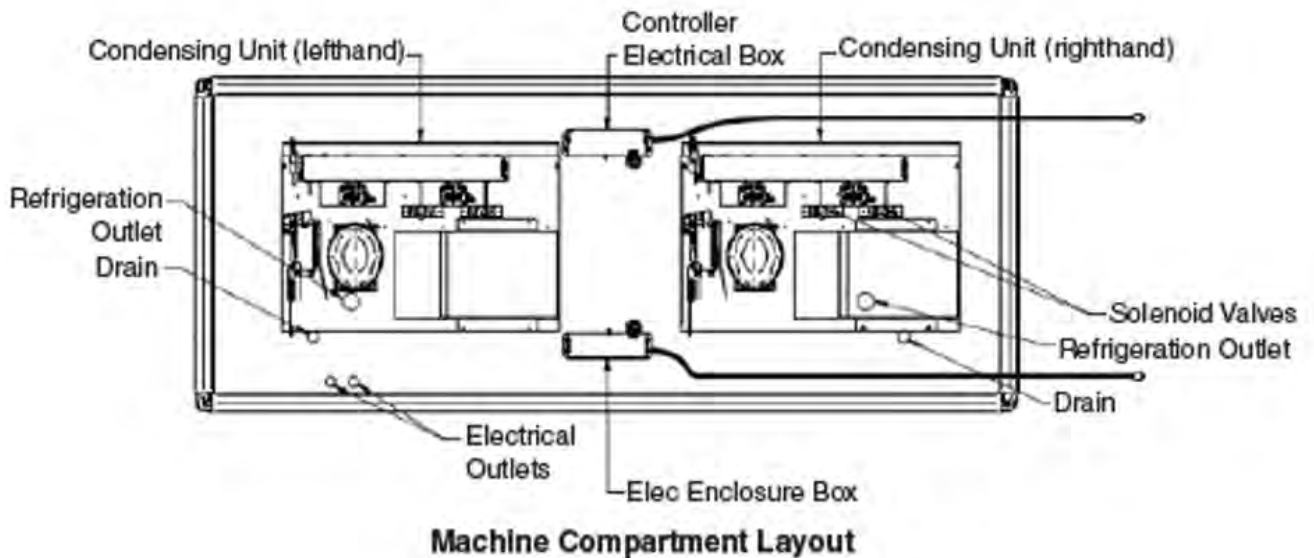







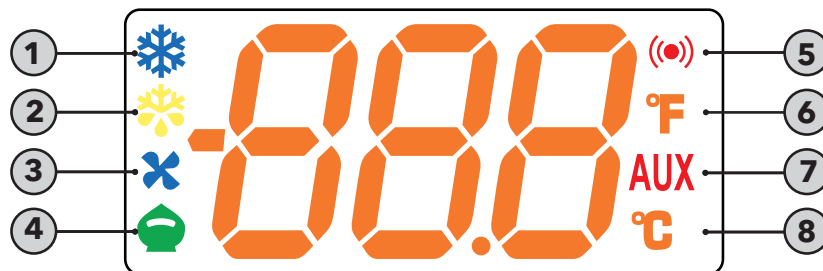

LED

RTN400 family controllers will also function even if a keyboard has not been connected.

With **KDEPlus** or **KDWPlus** keyboards (which are the same and guarantee the same functions), the display will be as follows:



Meaning of LEDs:

No	Icon	LED	Operation	Meaning
1		Compressor	Permanently on	compressor on
			Blinking	Delay, protection or start-up blocked
			OFF	otherwise
2		Defrost	Permanently on	Defrost active
			Blinking	Activated manually or from Digital Input
			OFF	otherwise
3		Fans	Permanently on	Fans active
			OFF	otherwise
4		Reduced SET / Economy	Permanently on	Energy Saving active
			Blinking	Reduced setpoint active
			OFF	otherwise
5		Alarm	Permanently on	alarm active
			Blinking	Alarm acknowledged
			OFF	otherwise
6		°F readout	Permanently on	°F setting (dro = 1)
			OFF	otherwise
7		AUX	Permanently on	Aux output active and/or light on
			Blinking	Deep cooling on
			OFF	otherwise
8		°C readout	Permanently on	°C setting (dro = 0)
			OFF	otherwise

N.B.: When the instrument is powered on it performs a lamp test, during which time the display and LEDs will flash for several seconds to check that they all function correctly.

KDEPLUS BUTTONS

The **KDEPlus** keyboard has 4 keys, as shown in the illustration:

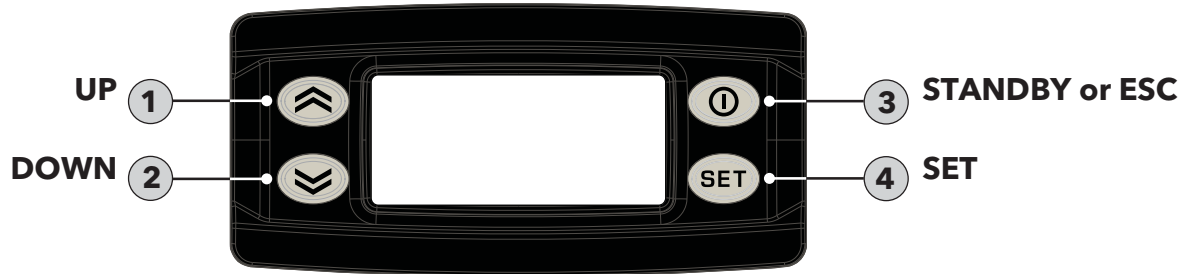

Each key has a different function depending on whether it is:

- Pressed and released
- Pressed for at least 5 seconds
- Pressed and held at start-up
- Pressed in combination with another key.

KEYS

The following table summarizes the function of each key:

No	Key	Action		
		Pressed and released	Press for at least 5 secs	Start-up
1		<ul style="list-style-type: none"> • Scrolls through menu items • Increases values 	Activates the Manual Defrost function (from outside menus).	---
2		<ul style="list-style-type: none"> • Scrolls through menu items • Decreases values 	Function can be configured by the user (from outside menus). (see parameter H32)	---
3		<ul style="list-style-type: none"> • Returns to the previous menu level • Confirms parameter value 	Activates the Stand-by function (from outside menus).	---
4		<ul style="list-style-type: none"> • Displays any alarms (if active) • Opens Machine Status menu • Confirms commands 	Opens the Programming Menu (User and Installer parameters)	When pressed during start-up it enables the user to select the application to be loaded.

SETPOINT: SETTING AND EDIT LOCK

To display the Setpoint value, press the **set** key to enter the "Machine Status" menu, then press the **set** key again when the "SEt" label is displayed.

The Setpoint value appears on the display. To change the Setpoint value, press the **UP** and **DOWN** keys within 15 seconds. Press **set** to confirm the modification.

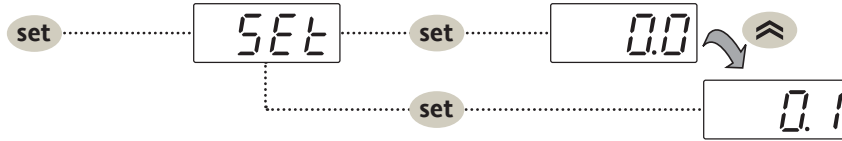

It is possible to disable the keypad on this device.

The keypad can be locked by programming the "LOC" parameter appropriately.

With the keypad locked, you can still access the "Machine Status" menu by pressing **set** to display the Setpoint, but you cannot edit it. To disable the keypad lock, repeat the locking procedure.

DISPLAY PROBES VALUE

To display the value read by probes connected to the device, press the **set** key and enter the "Machine Status" menu, then press the key again when one of the probe-related labels "Pb1...Pb5" press the **set** key again. The value measured by the associated probe will appear on the display.

NOTE: The displayed value is read-only and cannot be modified.

KDEPLUS BUTTONS

The **KDEPlus** keyboard has 4 keys, as shown in the illustration:



KEY-ACTIVATED FUNCTIONS

All models have the **UP** key set to enable the "Manual Defrost" function.

The DOWN and ESC keys can also be set to activate any other function required by the user.

The parameters for configuring the two keys are:

- **H11** = DOWN key configuration
- **H33** = ESC key configuration

The values that can be set apply to both keys and the functions that can be activated are:

H32/H33 value	Function to enable
0	disabled
1	defrost
2	reduced set
3	Light
4	Energy saving
5	AUX
6	Stand-by
7	Deep cooling cycle
8	Start/end defrost

TYPICAL SENSOR LOCATION

NOTE:

It is critical for merchandiser operating performance to have the sensors in this location. If for any reason, the sensors are removed, they need to be placed in the original location.

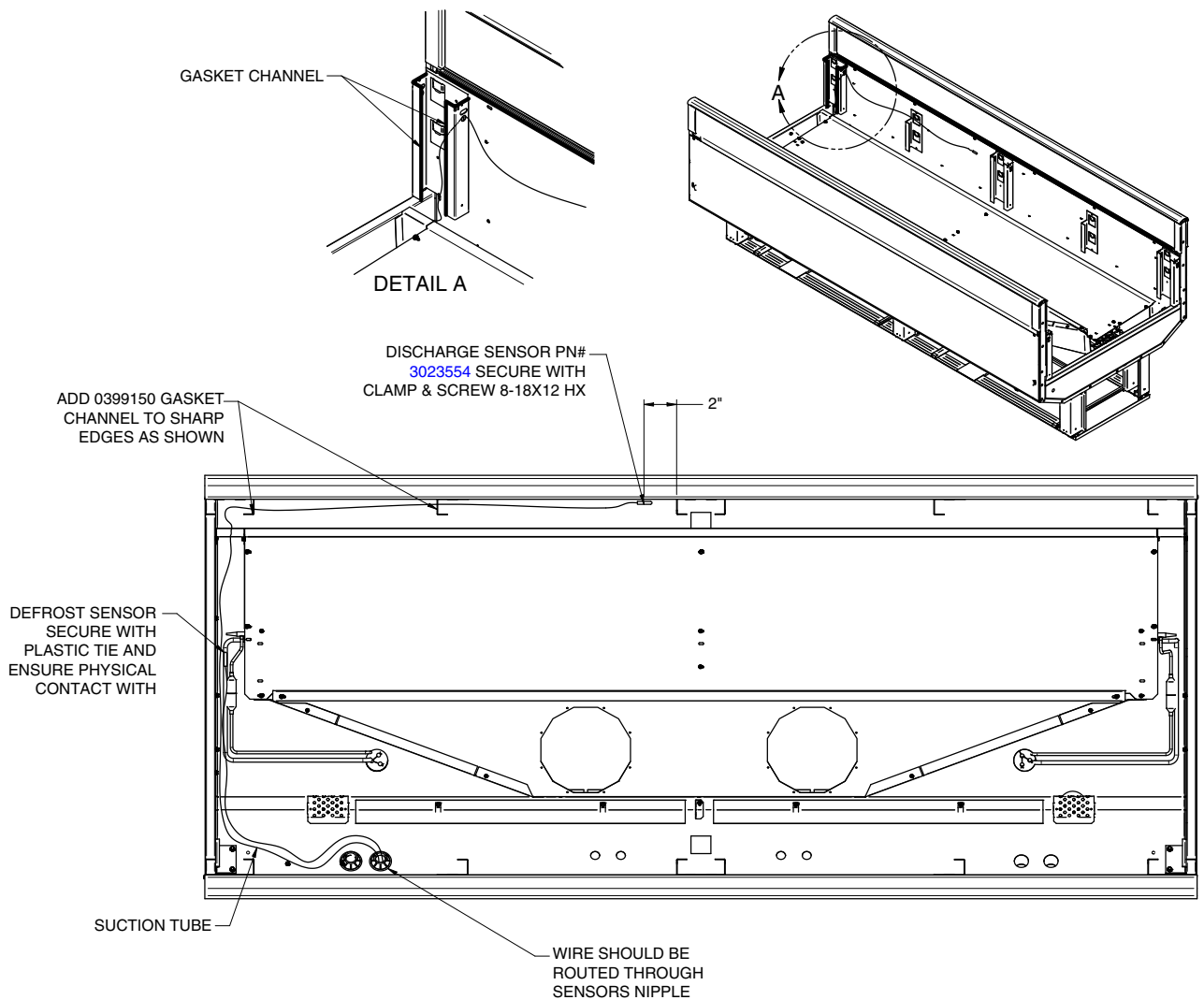

Sensor Location – FNGSC8A

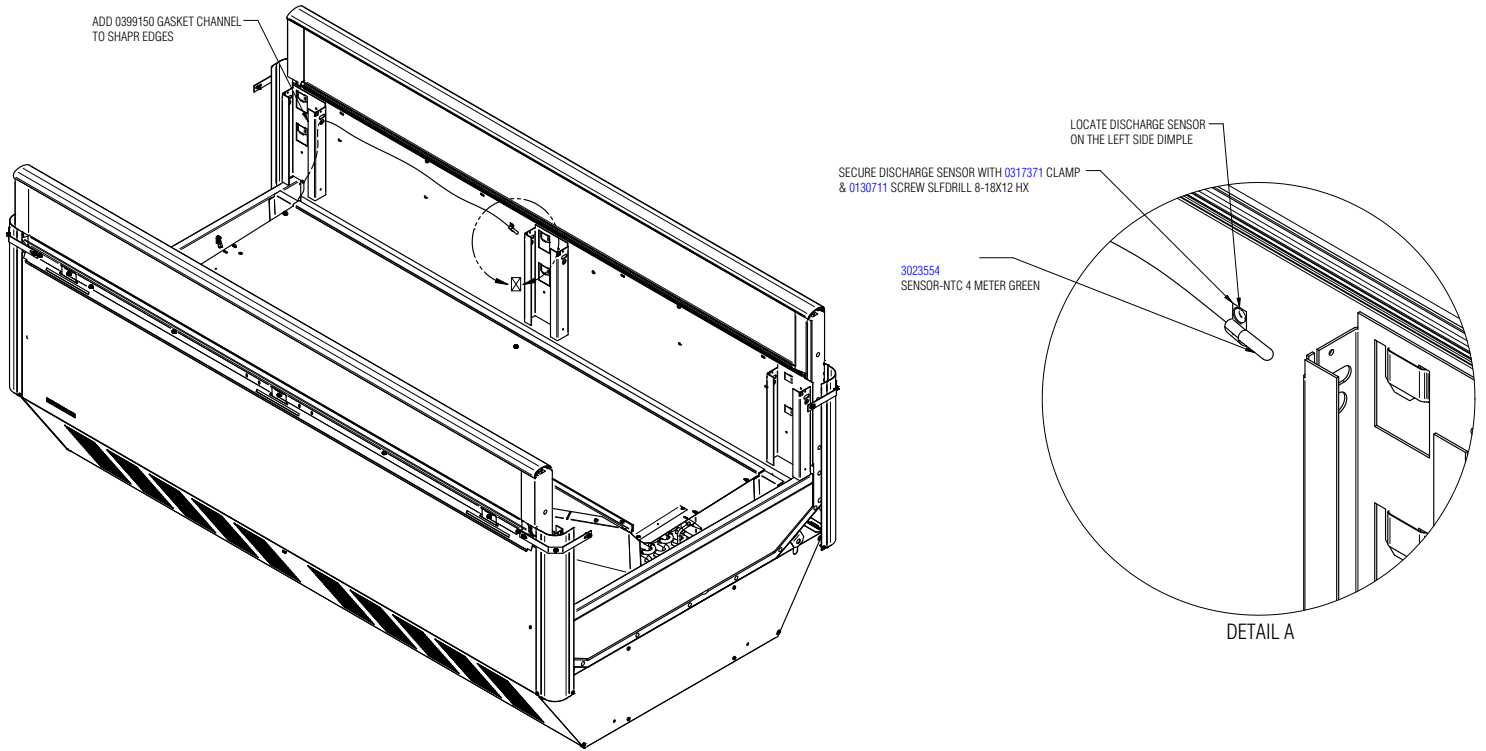

Discharge Air Sensor Location – FNGSC6A

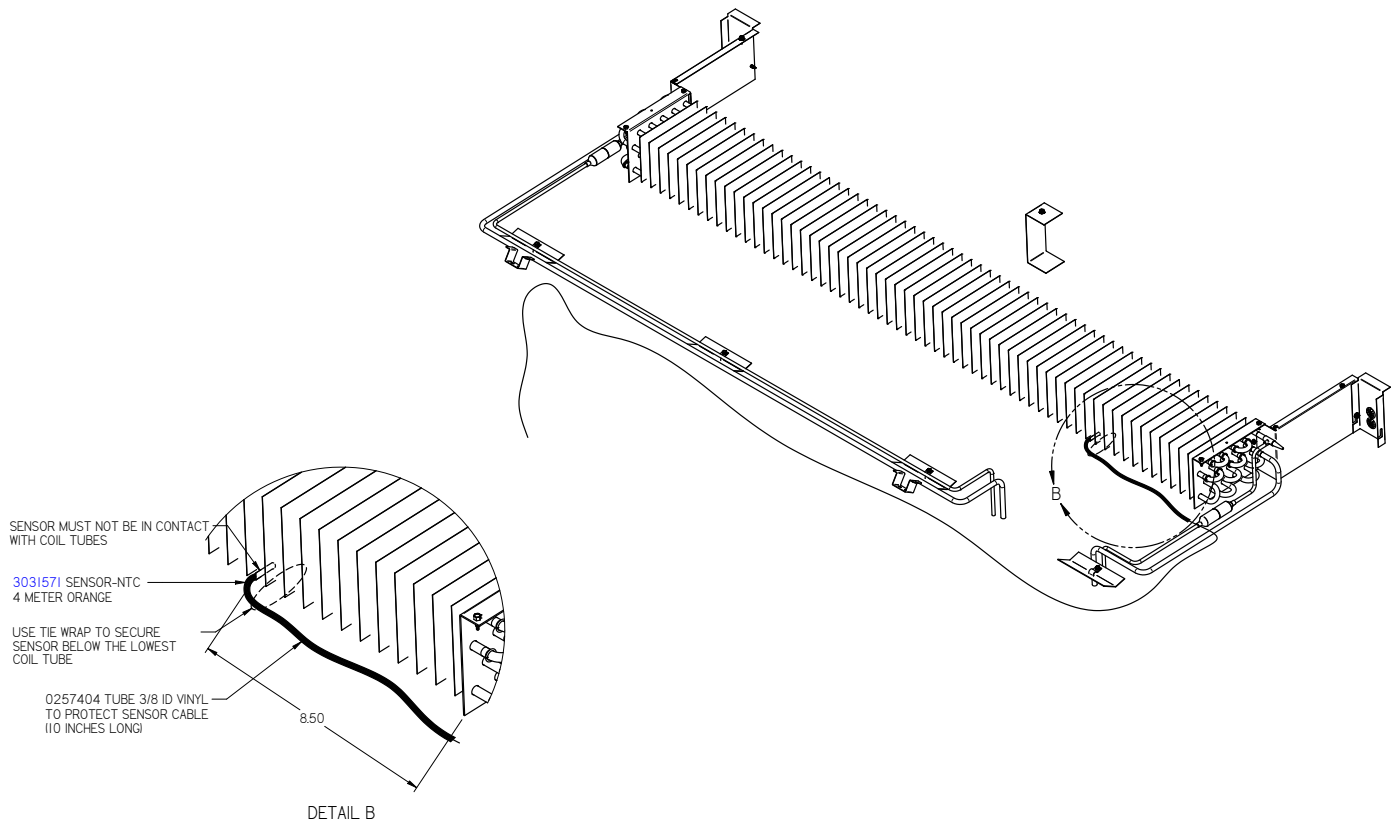

Defrost Sensor Location – FNGSC6A

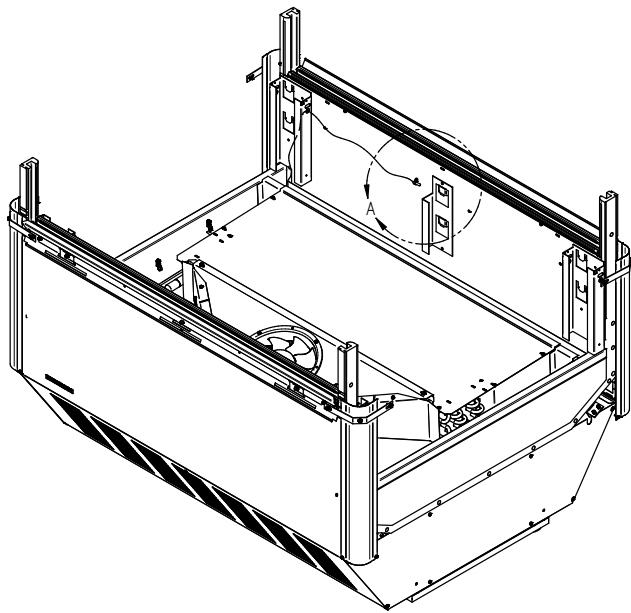

SECURE DISCHARGE SENSOR WITH 0317371 CLAMP
& 0130711 SCREW SLFDRILL 8-18X12 HX

3023554
SENSOR-NTC 4 METER GREEN

LOCATE DISCHARGE SENSOR
ON THE LEFT SIDE DIMPLE

DETAIL A

Discharge Air Sensor Location – FNGSC4A

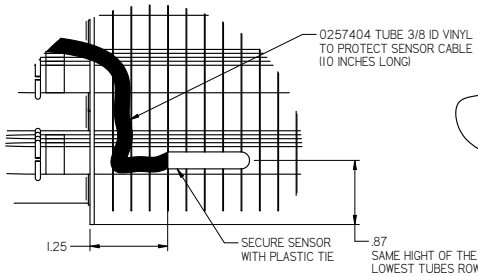

DETAIL B

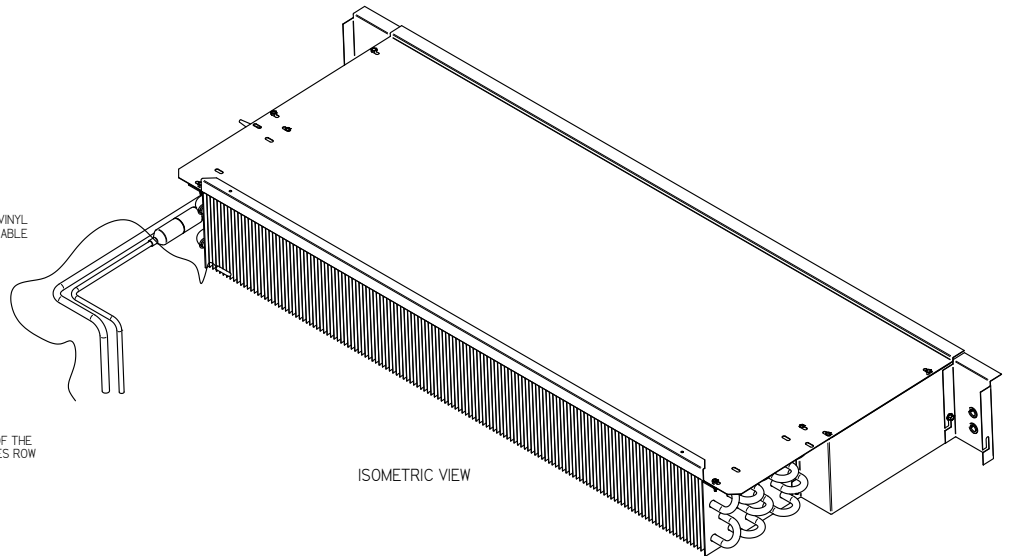

ISOMETRIC VIEW

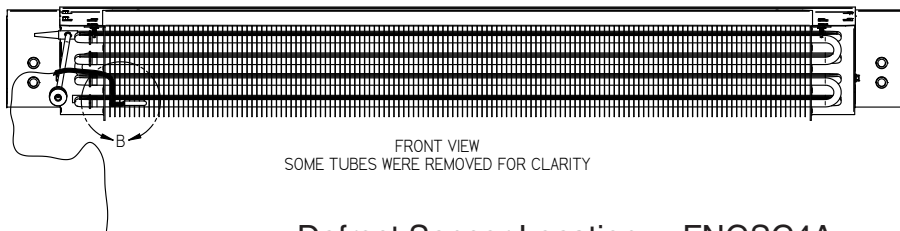

FRONT VIEW
SOME TUBES WERE REMOVED FOR CLARITY

Defrost Sensor Location – FNGSC4A

Controls and Adjustments

Refrigeration Controls

Defrost Controls

Model	Application	Product Application	Discharge Air Temperature	Tripping Dif (° F)	Controller Set Point (° F)	Defrost Frequency (per day)	Type of Defrost	Temp. Termination	Failsafe Time (min)
FNGSC8A	AP1	Med Temp - DOE	25 ° F to 43 ° F (-4 ° C to 6 ° C)	18	24 to 25 ° F (-4 to -3 ° C)	3	Hotgas	45 ° F (7 ° C)	50
	**AP1	Med Temp - NSF 7 Type 1	20 ° F to 38 ° F (-6 ° C to 3 ° C)	18	18 to 20 ° F (-7 to -6 ° C)			45 ° F (7 ° C)	
	**AP2	Frozen Food - DOE	-19 to -9 ° F (-28 to -22 ° C)	10	-20 to -19 ° F (-29 to -28 ° C)			38 ° F (3 ° C)	
FNGSC6A	AP1	Med Temp - DOE	22 ° F to 46 ° F (-5 ° C to 8 ° C)	24	21 to 22 ° F (-6 to -5 ° C)	3		45 ° F (7 ° C)	50
	**AP1	Med Temp - NSF 7 Type 1	16 ° F to 40 ° F (-8 ° C to 4 ° C)	24	15 to 16 ° F (-9 to -8 ° C)			45 ° F (7 ° C)	
	**AP2	Frozen Food - DOE	-19 to -9 ° F (-28 to -22 ° C)	10	-20 to -19 ° F (-29 to -28 ° C)			38 ° F (3 ° C)	
FNGSC4A	AP1	Med Temp - DOE	26 ° F to 44 ° F (-3 ° C to 7 ° C)	18	24 to 26 ° F (-4 to -3 ° C)	3		45 ° F (7 ° C)	50
	**AP1	Med Temp - NSF 7 Type 1	20 ° F to 38 ° F (-6 ° C to 3 ° C)	18	18 to 20 ° F (-7 to -6 ° C)			45 ° F (7 ° C)	
	**AP2	Frozen Food - DOE	-19 to -9 ° F (-28 to -22 ° C)	10	-17 to -16 ° F (-27 to -26 ° C)			38 ° F (3 ° C)	

Notes:

The cases are pre programmed with AP2 as default, which is low temp frozen food application.

If the customer needs Medium temp application, the default settings are to comply with NSF 7 Type 1.

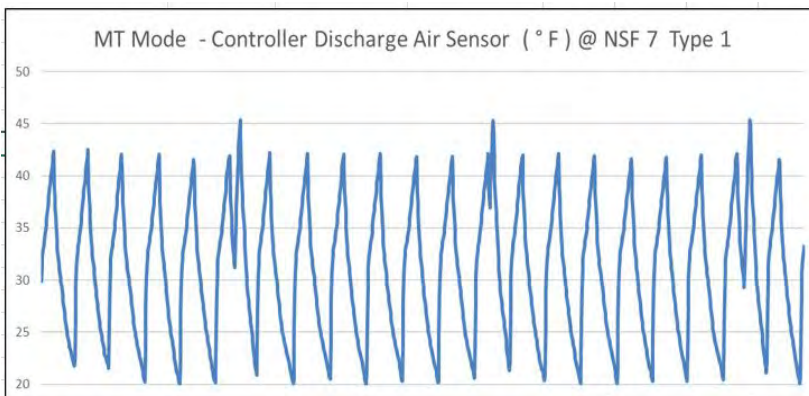

Example of FNGSC8A (Medium Temp.)

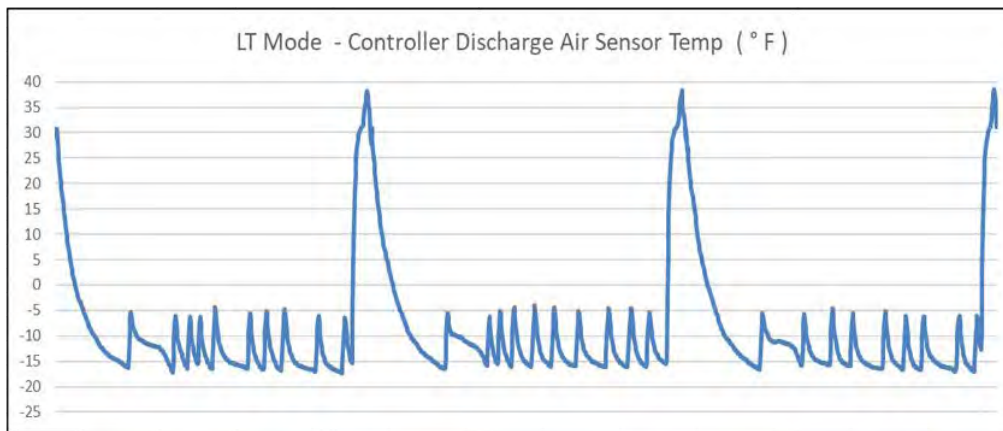

Example of FNGSC8A (Low Temp.)

The controller controls refrigeration temperature and is factory installed inside the control panel. Adjust the control to maintain the discharge air temperature shown above. Measure discharge air temperatures at the center of the discharge louver.

Defrosts are time initiated and temperature terminated for self-contained models. The defrost settings are factory set as shown above.

To ensure a thorough defrost, defrost must be terminated by the temperature termination setting — not by time.

LOAD LIMITS

Each merchandiser has a load limit decal. Shelf life of perishables will be short if load limit is violated.

AT NO TIME SHOULD MERCHANDISERS BE STOCKED BEYOND THE LOAD LIMITS INDICATED.



DO NOT BLOCK AIR LOUVERS.

Air flow in food compartment:

The main task of the air flow subsystem in the food compartment is to distribute cold air across the display case. Cold discharge air blowing through the honeycomb creates an air curtain that acts as an invisible barrier between the cold air inside and the warm air outside the case. This barrier helps to minimize infiltrations and keeps cold air inside the case. Make sure product is loaded below limit so that the air curtain continues is not disrupted.

STOCKING

Product should NOT be placed inside the merchandisers until merchandisers are at proper operating temperature.

Allow merchandiser 24 hours to operate before loading product.

Proper rotation of product during stocking is necessary to prevent product loss. Always bring the oldest product to the top and set the newest to the bottom.

AIR DISCHARGE AND RETURN FLUES MUST REMAIN OPEN AND FREE OF OBSTRUCTION AT

ALL TIMES to provide proper refrigeration and air curtain performance. Do not allow product, packages, signs, etc. to block these grilles. Do not use non-approved shelving, baskets, display racks, or any accessory that could hamper air curtain performance.

Do not allow product to be placed outside of the designated load limits in the illustration.

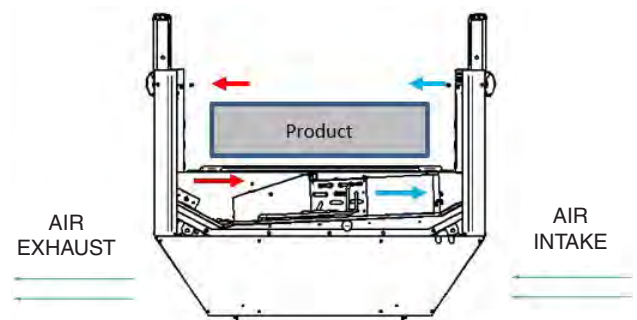

(FNGSC8A shown)

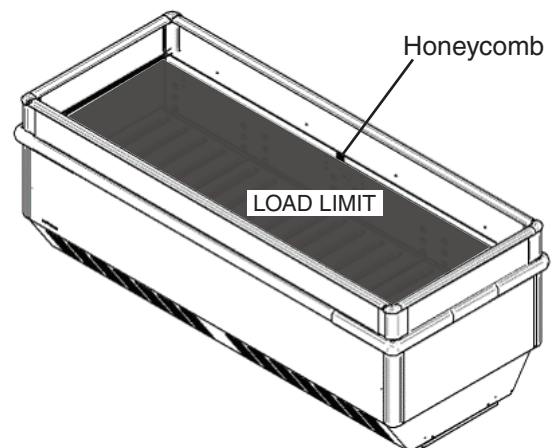

(FNGSC8A shown)

INSTALLING FDA/NSF REQUIRED THERMOMETER

These models have a thermometer. The thermometer is located at the top, interior of the merchandiser.

This is an NSF-7 & US FDA Food Code Required Thermometer

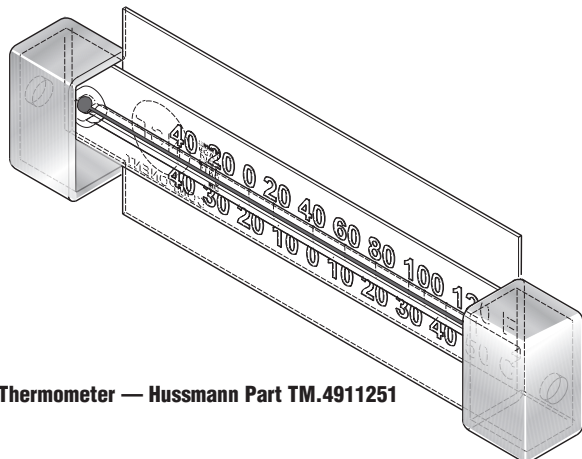

Thermometer — Hussmann Part TM.4911251

Suggested Mounting Locations
in Single Deck Glass Front
Impact Merchandisers

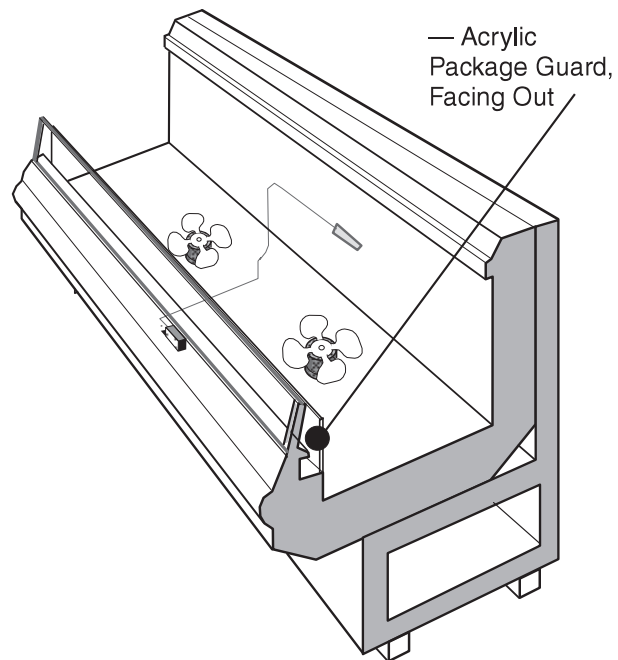

This thermometer is provided in response to United States
Food and Drug Administration (US FDA) Food Code [<http://www.fda.gov/>]
and
National Sanitation Foundation (NSF / ANSI) Standard 7 [<http://www.nsf.org/>]

Each installation will be different depending on how the unit is stocked, shopping patterns in the department and ambient conditions of the store. The suggested locations provided herein are possible locations. It is the responsibility of the purchaser / user to determine the location within the food storage area of the unit that best meets the code requirements above.

The thermometer may need to be moved several times to find the warmest location. Mounting options include flexible plastic for price tag molding application, magnet applied to back of flexible plastic for steel end wall, and double stick tape. Tape must not be exposed after installation.

Questions about either code should be addressed to local agencies or other appropriate officials.

MAINTENANCE

CARE AND CLEANING

Long life and satisfactory performance of any equipment is dependent upon the care it receives. To ensure long life, proper sanitation and minimum maintenance costs, these merchandisers should be thoroughly cleaned, all debris removed and the interiors washed down, weekly.

Exterior Surfaces

The exterior surfaces must be cleaned with a mild detergent and warm water to protect and maintain their attractive finish. **NEVER USE ABRASIVE CLEANSERS OR SCOURING PADS.**

Interior Surfaces

The interior surfaces may be cleaned with most domestic detergents, ammonia based cleaners and sanitizing solutions with no harm to the surface. Self contained models empty into a limited capacity evaporation pan, which will overflow if excess water is used in cleaning.

Do NOT Use:

- Abrasive cleansers and scouring pads, as these will mar the finish.
- Coarse paper towels on coated glass.
- Ammonia-based cleaners on acrylic parts.
- Solvent, oil or acidic based cleaners on any interior surfaces.
- Do not use high pressure water hoses.

- Do not flood merchandiser with water. **NEVER INTRODUCE WATER FASTER THAN THE WASTE OUTLET CAN REMOVE IT.**

Do:

- Remove the product and all loose debris to avoid clogging the waste outlet.
- Store product in a refrigerated area such as a cooler. Remove only as much product as can be taken to the cooler in a timely manner.
- **Disconnect electrical power before cleaning.**
- Thoroughly clean all surfaces with soap and hot water. **DO NOT USE STEAM OR HIGH WATER PRESSURE HOSES TO WASH THE INTERIOR. THESE WILL DESTROY THE MERCHANTISERS' SEALING CAUSING LEAKS AND POOR PERFORMANCE.**
- Lift hinged fan plenum for cleaning. Hook chain in rear panel to secure plenum during cleaning. **BE SURE TO REPOSITION THE FAN PLENUM AFTER CLEANING MERCHANTISER.**
- Take care to minimize direct contact between fan motors and cleaning or rinse water.
- Allow merchandisers to dry before resuming operation.
- After cleaning is completed, turn on power to the merchandiser.



WARNING

Product will be degraded and may spoil if allowed to sit in a non-refrigerated area.



WARNING

Do NOT allow cleaning agent or cloth to contact food product.

WARNING

Do NOT use HOT water on Cold glass Surfaces. This can cause the glass to shatter and could result in personal injury. Allow glass fronts, to warm before applying hot water.

REMOVING SCRATCHES FROM BUMPER

Most scratches and dings can be removed using the following procedure.

1. Use steel wool to smooth out the surface area of the bumper.
2. Clean area.
3. Apply vinyl or car wax and polish surface for a smooth glossy finish.

CLEANING UNDER FAN PLENUM

To facilitate cleaning, the fan plenum is hinged.

After cleaning be sure the plenum is properly lowered into position OR PRODUCT LOSS WILL RESULT due to improper refrigeration.

WARNING

— LOCK OUT / TAG OUT —

To avoid serious injury or death from electrical shock, always disconnect the electrical power at the main disconnect when servicing or replacing any electrical component. This includes, but is not limited to, such items as doors, lights, fans, heaters, and thermostats.

WARNING

SHUT FANS OFF DURING CLEANING PROCESS.



CLEANING DISCHARGE AIR HONEYCOMB

Discharge air honeycomb should be cleaned every six months. Dirty honeycomb will cause merchandisers to perform poorly. The honeycomb may be cleaned with a vacuum cleaner. Soap and water may be used if all water is removed from the louvers cells before replacing. Be careful not to damage the honeycomb

1. Remove screws to release retainer. Make sure insulation between honeycomb and cover is placed properly to assure cover surface temperature above dew point.
2. Clean and dry the honeycomb.
3. After cleaning, replace in reverse order. Damaged honeycomb must be replaced.

 <h2 style="margin: 0;">CAUTION</h2>
<p>DO NOT FLOOD!</p> <p>Use only enough water necessary to clean surface. Water must not drip down the case!</p> <p>Never use ammonia based cleansers, abrasive cleansers, or scouring pads.</p>

Always wear gloves and protective eye wear when cleaning near sharp coil fins and dust particles.



CLEANING STAINLESS STEEL SURFACES

Use non-abrasive cleaning materials, and always polish with grain of the steel. Use warm water or add a mild detergent to the water and apply with a cloth. Always wipe rails dry after wetting.

Use alkaline chlorinated or non-chlorine containing cleaners such as window cleaners and mild detergents. Do not use cleaners containing salts as this may cause pitting and rusting of the stainless steel finish. Do not use bleach.

CLEANING COILS

Condenser coils should be cleaned at least once per month. Additional cleaning may be needed depending on the operational environment. A dirty condenser blocks normal airflow through the coils.

Airflow blockage increases energy consumption and reduces the merchandiser's ability to maintain operating temperature.

To clean the coils, use a vacuum cleaner with a wand attachment and a soft (non-metallic) brush to remove dirt and debris. Do not bend coil fins.

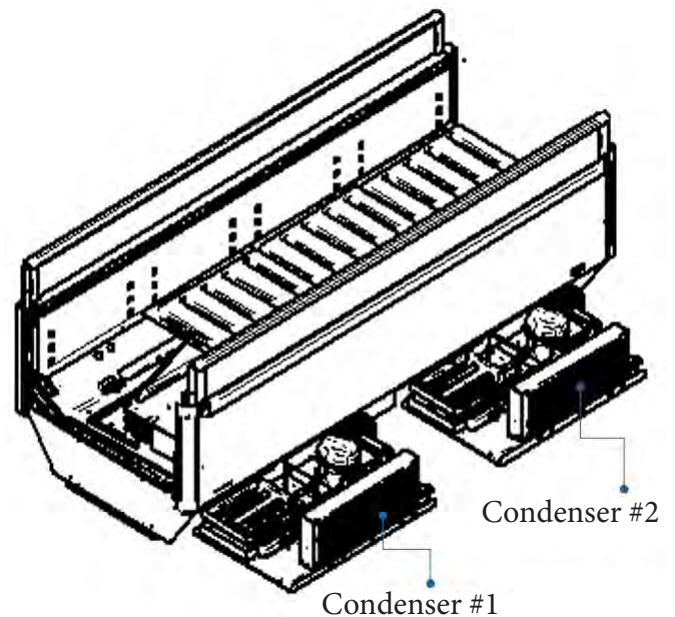

NEVER USE SHARP OBJECTS AROUND COILS.

Use a soft brush or vacuum brush to clean debris from coils. *Do not puncture coils!* Do not bend fins. Contact an authorized service technician if a coil is punctured, cracked, or otherwise damaged.

ICE in or on the coil indicates the refrigeration and defrost cycle is not operating properly. Contact an authorized service technician to determine the cause of icing, and to make adjustments as necessary. To maintain product integrity, move all product to a cooler until the unit has returned to normal operating temperatures.



CAUTION

Evaporation Pan is Hot!
and poses risk of bodily injury – Always Wear gloves and protective eye wear when servicing. Turn off evaporation pan heater, and allow pan to cool.

CLEANING EVAPORATION PAN

The condensate water outlet for self contained models empties into a limited capacity evaporation pan.

Debris or dirt accumulation inside the condensate evaporation pan or on the heater coil will reduce the pan's evaporation capacity and cause premature heater failure. The evaporation pan waste water will overflow and spill onto the floor if the heater is not properly operating.

Remove accumulated debris from the evaporation pan. Wipe down heater coil with a cloth and warm water. Be sure to remove any dirt, debris or liquids from the heater coil.

Water introduced during cleaning will cause the evaporation pan to overflow.



PRECAUTION CLEANING PRECAUTIONS

When Cleaning:

- Do not use high pressure water hoses
- Do not introduce water faster than waste outlet can drain
- NEVER INTRODUCE WATER ON SELF CONTAINED UNIT WITH AN EVAPORATION PAN
- NEVER USE A CLEANING OR SANITIZING SOLUTION THAT HAS OIL BASE (these will dissolve the butyl sealants) or an AMMONIA BASE (this will corrode the copper components of the merchandiser)
- TO PRESERVE THE ATTRACTIVE FINISH:
- Use a water and a mild detergent for the exterior only
- Do NOT use a chlorinated cleaner on any surface
- Do NOT use abrasives or steel wool scouring pads (these will mar the finish)

Self-Contained Refrigeration Equipment Maintenance Check List

***** Warranty does not cover issues caused by improper installation or lack of basic preventative maintenance. *****

Record starting date	
Store Name and Number	
Store Address	
Unit Model Number	
Unit Serial Number	
Contractor/Technician	

	Technician										
	PM date										

PM activity-For visual inspection items, denote "ok or complete" in the column to right when PM has been performed. For measured data requested, record data requested in the appropriate column to the right)	Quarterly	Semi-Annually	Q1	Q2	Q3	Q4	Q1	Q2	Q3	Q4
Check in with store manager, record any complaints or issues they have with unit.	X									
Look unit over for any damage, vibrations or abnormal noise.	X									
Verify unit is level side to side and front to rear.	X									
Confirm refrigerant lines properly are secured and not touching or rubbing other lines, wires or frame work.	X									
Verify fan motors and motor mounts are tight.	X									
Confirm fan blade/s are tight and not rubbing or hitting.	X									
Make sure all electrical connections, factory and field, are tight.	X									
Verify electrical connections at lamps are they secure and dry.	X									
Check for and replace any frayed or chaffed wiring.	X									
Check all electrical wiring make sure it is secured and not on any sharp edges or hot lines.	X									
Check for air disturbances external to the unit. Heat and air registers, fans, and doors etc.	X									
Check for water leaks.	X									
Clean evaporator coil/s and fan blade/s. Do not use an acid base cleaner. Rinse off any cleaner residue.		X								
Clean discharge air honeycombs or grilles. Do not use an acid base cleaner. Rinse off any cleaner residue.		X								
Clean condenser coil/s and fan blade/s. Do not use an acid base Cleaner. Rinse off any cleaner residue.		X								
Clean condensate drain pan and drain line.		X								
Verify condensate drain lines are clear and functioning.		X								
Record voltage reading at unit with unit off?		X								
Verify condenser and evaporator fans are working.	X									
Record condenser air inlet temperature	X									
Record condenser air outlet temperature	X									
Is condenser air inlet or air exhaust restricted or recirculating?	X									
Verify there are no visual oil or refrigerant leaks.	X									
Record voltage reading with unit running.		X								
Record compressor amp draw.		X								
Record defrost heater voltage and amp draw.		X								
Record anti-sweat heater voltage and amp draw.		X								
Record case product temperature.	X									
Record unit discharge air temperature.	X									
Record unit return air temperature.	X									
Record ambient conditions around unit (wet Bulb temperature and dry bulb temperature).	X									
Check product loading, do not load beyond the units load limits.	X									
Verify clearances on sides/back of unit.	X									
Check unit controller for proper operation. See controller or 1/0 Manual for proper controller operation.		X								
Confirm door switches function.	X									
Verify unit doors and lids work and are sealed correctly.	X									
Verify that all the panels, shields and covers are in place.	X									

Technician Notes:

4-6 INSTALLATION

NOTES:

SERVICE

REPLACING EVAPORATOR MOTORS

Should it ever be necessary to service or replace the fan motors be certain that the fan blades are reinstalled correctly. **The blades must be installed with raised embossing (part number on plastic blades) positioned as indicated on the parts list.**

Unplug power cords before servicing.

Parts may be ordered at Hussmann's Performance Parts e-store:

<https://parts.hussmann.com/>

or

Call toll free: 855-487-7778

Required Tools:

- Screwdriver
- 3/8" Allen Wrench

For access to these fans:

1. Remove product and place in a refrigerated area. Make sure the power is off to the case.
2. Make sure there is no voltage in the refrigerator. Remove pan displays to have access to the evaporation section as shown below.

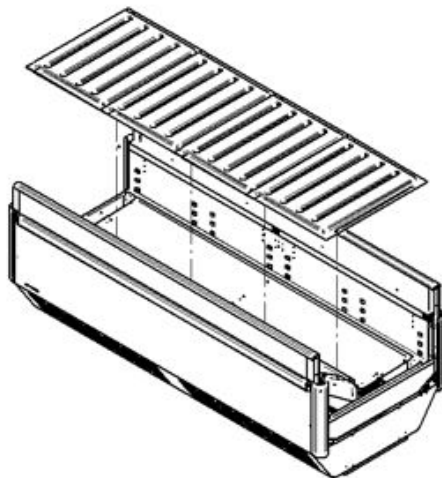

3. Remove motor screws as shown below.

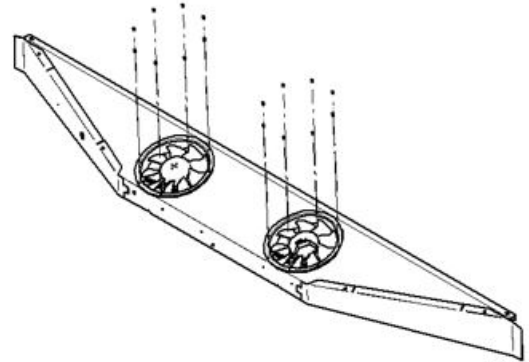

4. Take off motors from assembly and disconnect harness.

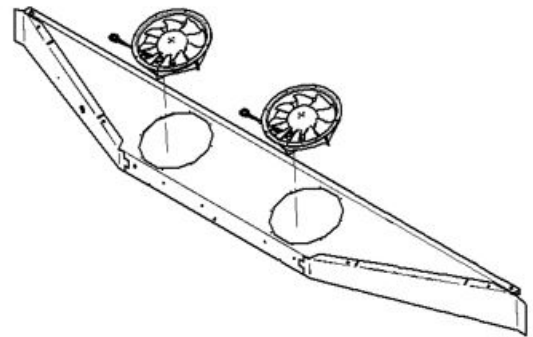

5. Replace new motors and reverse the process. Make sure everything is hand-tight and is working correctly.



WARNING

— LOCK OUT / TAG OUT —

To avoid serious injury or death from electrical shock, always disconnect the electrical power at the main disconnect when servicing or replacing any electrical component. This includes, but is not limited to, such items as doors, lights, fans, heaters, and thermostats.

REPLACING INVERTER

(Applies only for FNGSC4 and FNGSC8)

Unplug the power cords before servicing.

Parts may be ordered at Hussmann's Performance
Parts e-store:

<https://parts.hussmann.com/>

or

Call toll free: 855-487-7778

Required Tools:

- Screwdriver / Philips Tip
- 1/4" Allen Wrench

1. Remove product and place in a refrigerated area. Make sure the power is off to the case.
2. Make sure there is no voltage in the refrigerator. Remove rear lower panel as shown below.

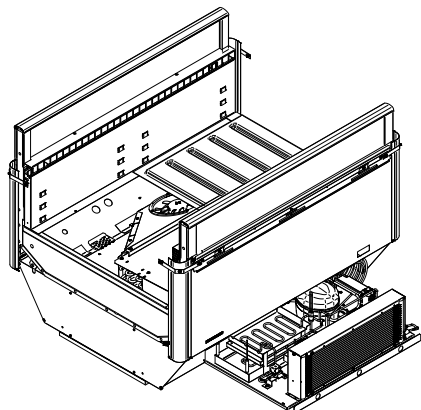
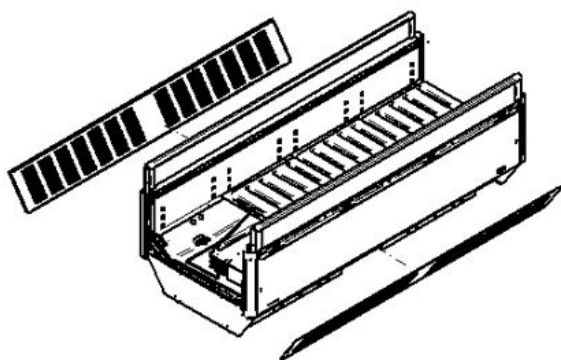

FNGSC4 Shown

P/N 3141959_E

3. Remove motor screws

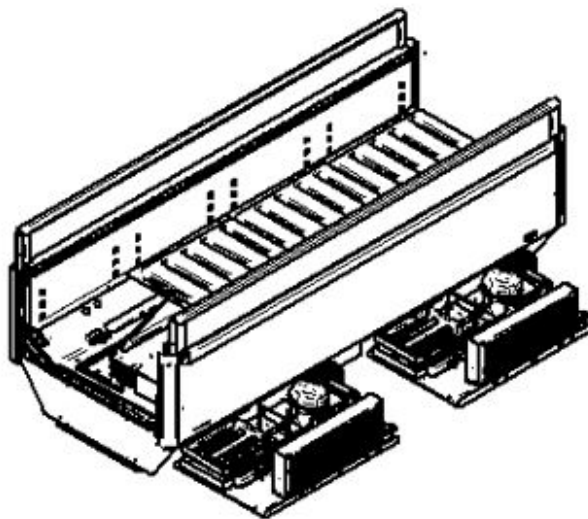

4. Disconnect inverter harness and ground.
5. Take off the inverter screws.

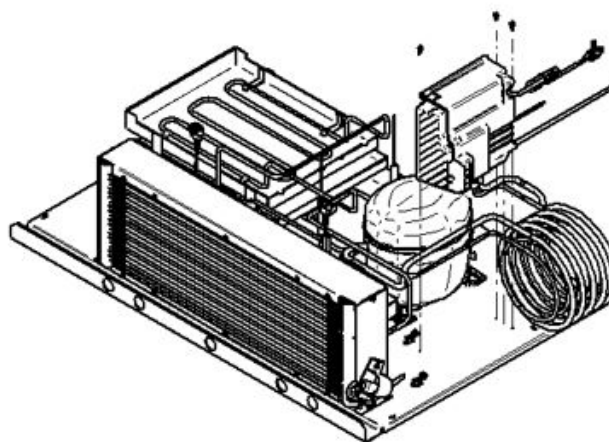

6. Replace inverter with the new one.
7. Reverse the process, and make sure screws are hand-tight and everything is working properly.

**WARNING**

Product will be degraded and may spoil if
allowed to sit in a non-refrigerated area.

REPLACING CONDENSER MOTOR

Unplug the power cords before servicing.

Parts may be ordered at Hussmann's Performance Parts e-store:

<https://parts.hussmann.com/>

or

Call toll free: 855-487-7778

Required Tools:

- Screwdriver / Philips Tip
- 1/4" Allen Wrench

1. Remove product and place in a refrigerated area. Make sure the power is off to the case.
2. Make sure there is no voltage in the refrigerator. Remove rear lower panel as shown in the illustration.
3. Slide out the condensing unit. Be careful using the condensing unit base to pull it out. Make sure not to stress or interfere with other parts.

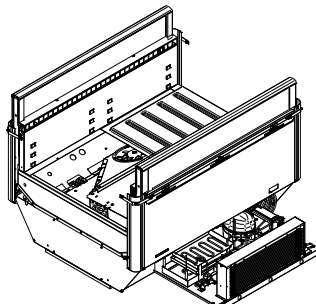
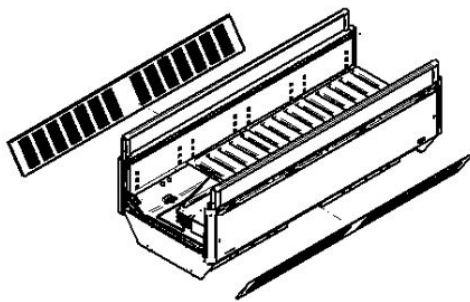

FNGSC4 Shown

4. Disconnect condenser motor harness.
5. If a flexible extension is used, skip Step 6.
6. Release screws to partially remove venturi assembly.

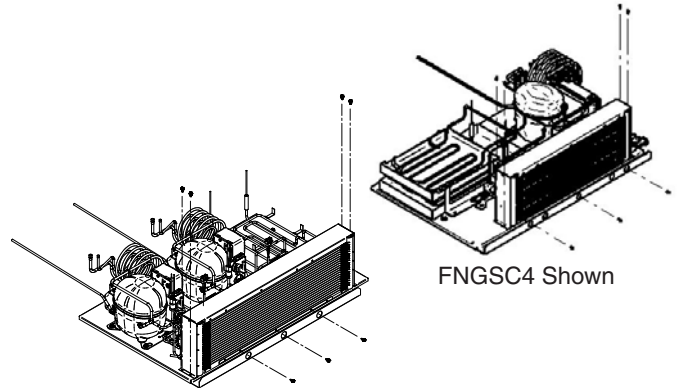

FNGSC6 Shown

FNGSC4 Shown

7. Release screws to remove condenser fan assembly.

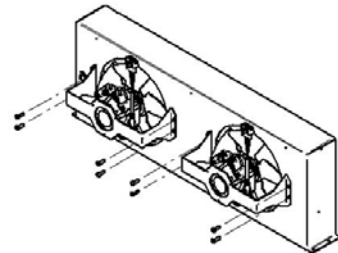

8. Release motor screws to get to motor / blade assembly.

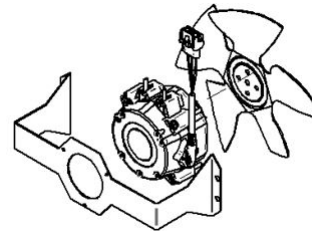

9. Change failed part.
10. If the only damaged part is the motor, remove blade.
11. Reverse the process and make sure everything is in place and working.

REPLACING COMPRESSOR

Unplug the power cords before servicing.

Parts may be ordered at Hussmann's Performance Parts e-store:

<https://parts.hussmann.com/>

or

Call toll free: 855-487-7778

Required Tools:

- Screwdriver / Philips Tip
- 1/4" Allen Wrench
- Copper Tubing Cutter
- Blow Torch

1. Remove product and place in a refrigerated area. Make sure the power is off to the case.
2. Make sure there is no voltage in the refrigerator. Remove lower panels.

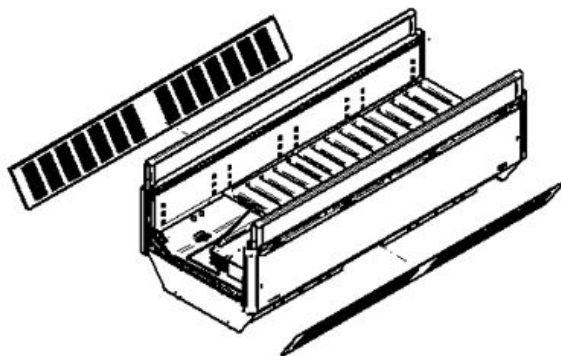

FNGSC8A Shown

3. Make sure there is no refrigerant left in the system. Refer to Page 2-6 - Steps to Recover Refrigerant.

4. Remove welded joints that connect the condensing units and the evaporator.

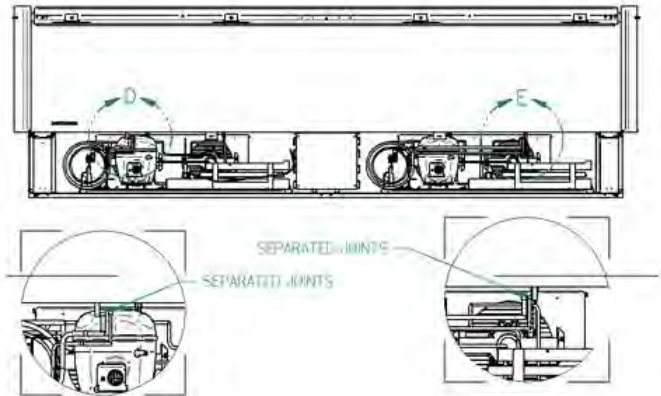

FNGSC8A Shown

5. Slide out the condensing unit completely. Be careful using the condensing unit base to pull it out. Make sure not to stress or interfere with other parts.

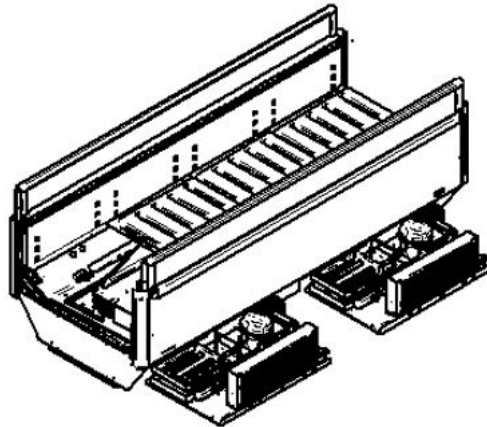

FNGSC8A Shown

6. Disconnect all wires and harness from the compressor.

REPLACING DRAIN HEATER

Unplug the power cords before servicing.

7. Take off compressor screws.

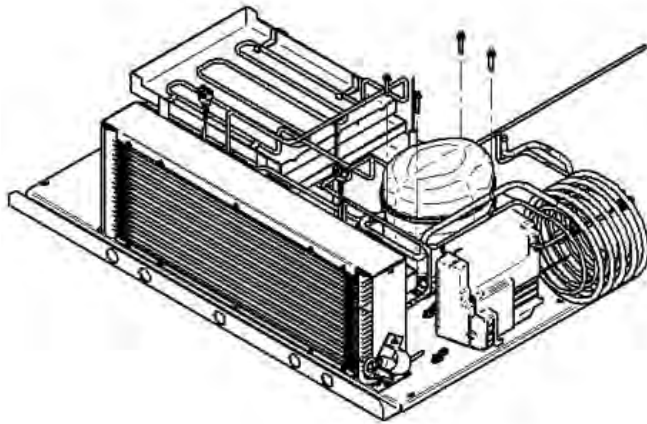

FNGSC8A Condensing Unit Shown

8. Remove welded joints to the compressor and replace with new compressor.

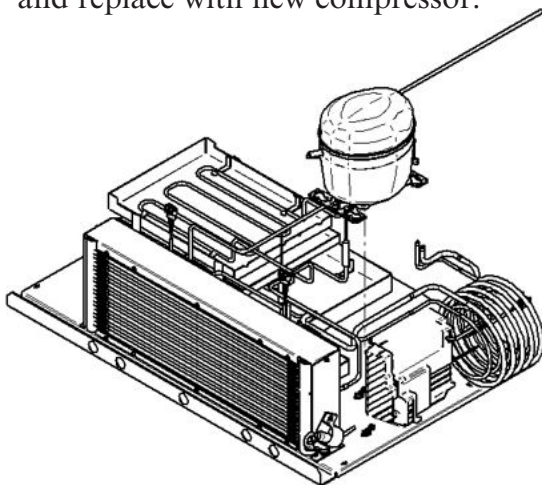

FNGSC8A Condensing Unit Shown

9. Reverse the process and make sure everything is in place.

Parts may be ordered at Hussmann's Performance Parts e-store:
<https://parts.hussmann.com/>
 or
 Call toll free: 855-487-7778

Required Tools:

- Screwdriver / Philips Tip
- 1/4" Allen Wrench

1. Remove product and place in a refrigerated area. Make sure the power is off to the case.
2. Make sure there is no voltage in the refrigerator. Remove pan displays to have access to the evaporation section.

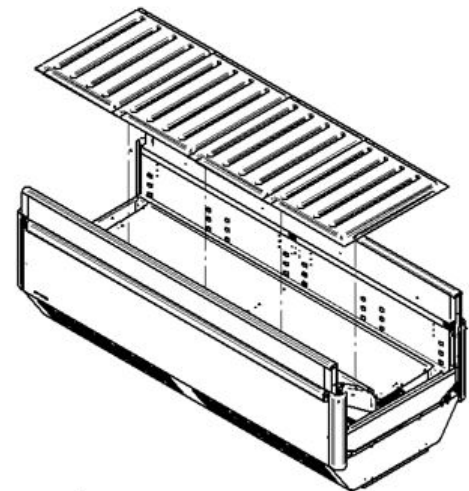

FNGSC8A Condensing Unit Access

- Remove front lower panel and take off the electric enclosure box cover.

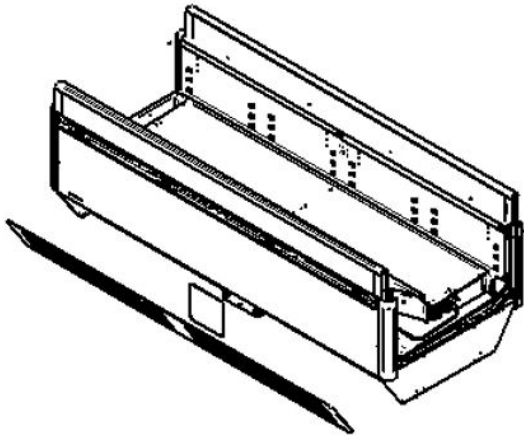

FNGSC8A Shown

- Disconnect the evap heater harness from Wago connectors.
- Remove clip jiffies and replace the drain heater. Ensure the harness routed as it was previously.

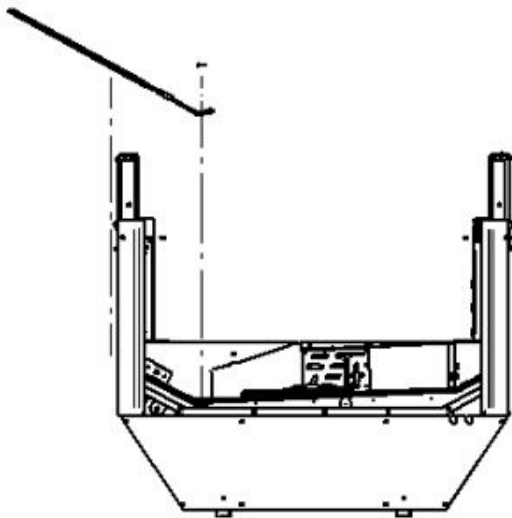

REPLACING PAN HEATER

Unplug the power cords before servicing.

Parts may be ordered at Hussmann's Performance Parts e-store:

<https://parts.hussmann.com/>

Call toll free: 855-487-7778

or

Required Tools:

- Screwdriver / Philips Tip
- 1/4" Allen Wrench

- Remove product and place in a refrigerated area. Make sure the power is off to the case.
- Make sure there is no voltage in the refrigerator. Remove lower panels.

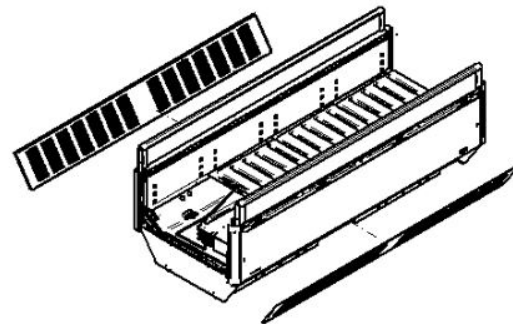

FNGSC8A Shown

- Slide out the condensing unit completely (Fig B). Be careful using the condensing unit base to pull it out. Make sure not to stress or interfere with other parts.

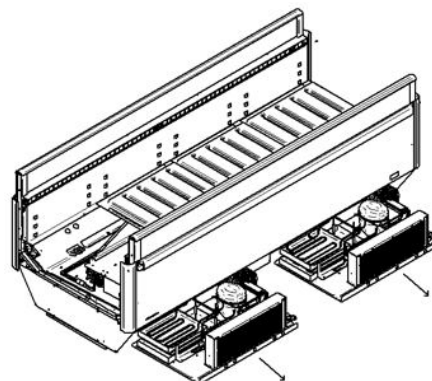

FNGSC8A Shown

REPLACING SOLENOID VALVES

Unplug the power cords before servicing.

4. Remove condensate pan screws and disconnect heater wires.

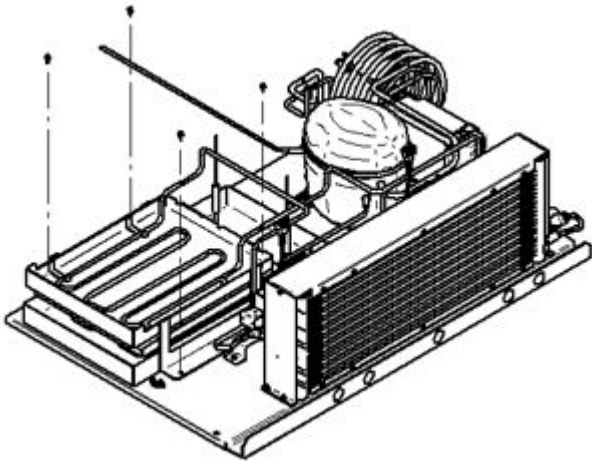

FNGSC8A Shown

5. Take off the condensate pan and replace heater.

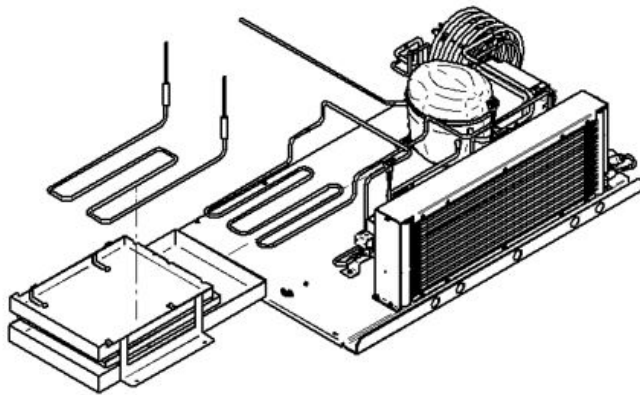

FNGSC8A Shown

6. Reverse the process and make sure everything is in place.

Parts may be ordered at Hussmann's Performance Parts e-store:
<https://parts.hussmann.com/>

Call toll free: 855-487-7778

or

Required Tools:

- Screwdriver / Philips Tip
- 1/4" Allen Wrench
- Copper Tubing Cutter
- Blow Torch

1. Remove product and place in a refrigerated area. Make sure the power is off to the case.
2. Make sure there is no voltage in the refrigerator. Remove rear lower panel.

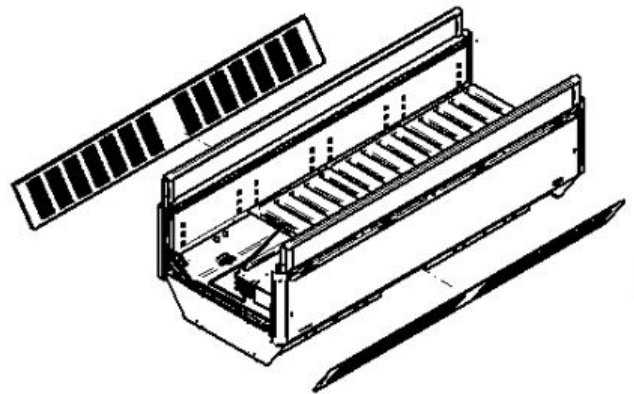

FNGSC8A Shown

5-8 SERVICE

3. Make sure there is no refrigerant left in the system.
4. Slide out the condensing unit. Be careful using the condensing unit base to pull it out. Make sure not to stress or interfere with other parts.

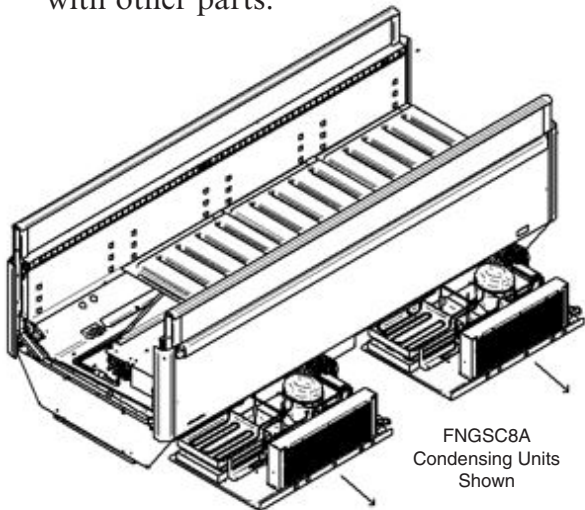

5. Remove coil by pulling up and disconnect wires.
6. Release clamps and remove welded joints from the valves.
7. Replace solenoid valves.

FNGSC8A, FNGSC4A
Condensing Unit

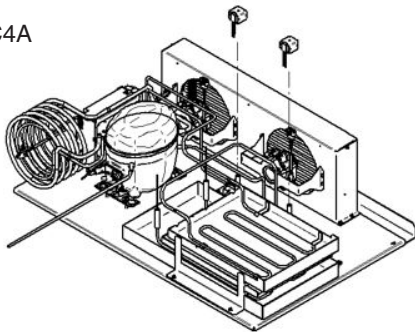

FNGSC6A
Condensing Unit

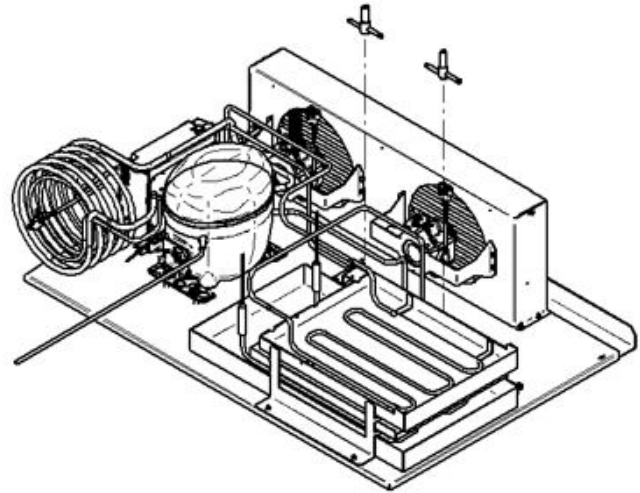
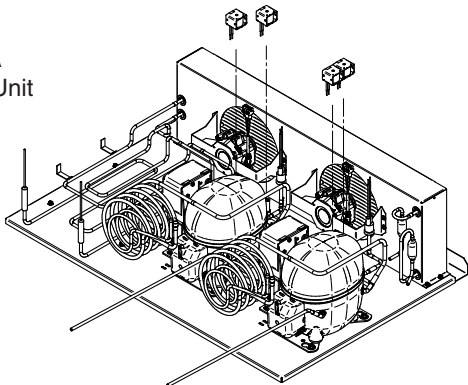

8. Reverse the process and make sure everything is in place.

INVERTER BOARD DIAGNOSTICS

Diagnostics:

The Fullmotion CF10B Inverter has two diagnostics methods, by visual light emission using a LED indication, or by serial communication protocol.

LED indication:

The LED diagnostics function helps service technicians to diagnose possible fault components by blinking a LED inside the box in different patterns. Basically, it indicates if there is a problem with compressor CF10B Inverter or Thermostat. The table below describes the failure modes:

LED Status	Period	Color	Description
1 Flash	30 seconds	Green	Normal operation
2 Flashes	5 seconds	Green	Communication problem
3 Flashes	5 seconds	Red	Inverter problem
4 Flashes	5 seconds	Orange	Compressor problem
No Flash	-	-	No input power / Damaged inverter

FNGSC-A Visual Depiction on Non-Incendive Replacement Parts



Main Switch



Solid State Relay



Control RTN400



Control Display KDE

⚠ WARNING

Component parts are specifically chosen for propane exposure and therefore non-incendive and non-sparkling. Component parts shall be replaced with identical components, and servicing shall be done by factory authorized service personnel only, so as to minimize the risk of possible ignition due to incorrect parts or improper service.

TROUBLESHOOTING GUIDE

PROBLEM	PROBABLE CAUSE	SOLUTION
Compressor will not start. (no noise)	<ol style="list-style-type: none"> 1. Power disconnected 2. Blown fuse or breaker 3. Defective or broken wiring 4. Defective overload 5. Defective temperature control 	<ol style="list-style-type: none"> 1. Check service cord or wiring connection 2. Replace fuse or reset breaker 3. Repair or replace 4. Replace 5. Replace
Compressor will not start; cuts out on overload.	<ol style="list-style-type: none"> 1. Low voltage 2. Defective compressor 3. Defective relay 4. Restriction (pinched cap tube) 5. Restriction (moisture) 6. Condenser blocked with dust and dirt 7. Defective condenser fan motor 	<ol style="list-style-type: none"> 1. Cabinet voltage must not be more than 5% below rating 2. Replace 3. Replace 4. Repair or replace 5. Leak check, replace drier evacuate and recharge 6. Clean condenser 7. Replace
Warm storage temperature	<ol style="list-style-type: none"> 1. Temperature control not set properly 2. Short or refrigerant 3. Cabinet location too warm 4. Refrigerant over-charge 5. Low voltage, compressor cycling on overload 	<ol style="list-style-type: none"> 1. Reset control. Rotate knob Clockwise 2. Leak check, replace drier evacuate and recharge 3. Move to cooler location or correct excessive heat source 4. Purge system, evacuate and recharge 5. Compressor voltage must not be more than 5% below rating
Compressor runs continuously; product too warm.	<ol style="list-style-type: none"> 1. Short of refrigerant 2. Inefficient compressor 3. Coil iced up 	<ol style="list-style-type: none"> 1. Leak check, replace drier, evacuate and recharge 2. Replace 3. Force manual defrost
Compressor runs continuously; product too cold	<ol style="list-style-type: none"> 1. Defective control 2. Control sensing element not in positive contact 3. Short on refrigerant 	<ol style="list-style-type: none"> 1. Replace 2. Assure proper contact 3. Leak check, replace drier evacuate and recharge

TROUBLESHOOTING GUIDE

PROBLEM	PROBABLE CAUSE	SOLUTION
The refrigeration system is noisy	<ol style="list-style-type: none"> 1. Screws and bolts are loose 2. The case is not level 	<ol style="list-style-type: none"> 1. Make sure bolts and screws are tightened. 2. Level the case. use leveling shims if necessary.
Condensation	<ol style="list-style-type: none"> 1. Store temperature or humidity is outside of proper operating conditions. 2. Insufficient air circulation 3. Hampered air curtain 	<ol style="list-style-type: none"> 1. Check case location 2. Check the operation of fans and wiring. 3. Check electrical connections. 4. Make sure air curtain is working properly
Water leaks; unpleasant odor	<ol style="list-style-type: none"> 1. Case drains are obstructed or damaged. 2. Water collection tray is sealed incorrectly. 3. Water collection tray is sealed incorrectly. 4. Water collection tray overflows. 	<ol style="list-style-type: none"> 1. Release the drains 2. Repair or replace the drains 3. Seal piping properly 4. Check evaporation heater wiring. 5. Check the operation of evaporation heater.
Frost or ice buildup	<p><i>Inside the cabinet:</i></p> <ol style="list-style-type: none"> 1. Fans do not work in the evaporator. 2. Sdef probe is detached 3. Air currents that alter the circulation of refrigerated air. 	<ol style="list-style-type: none"> 1. Check electrical connections. 2. Check the ventilation inside the store.



HUSSMANN[®]

**To obtain warranty information
or other support, contact your
Hussmann representative.
Please include the model and
serial number of the product.**

Hussmann Corporation, Corporate Headquarters: Bridgeton, Missouri, U.S.A. 63044-2483