

GSVM-A

Medium Temperature Self Contained Open Vertical Merchandiser

with R-290 Refrigerant

WARNINGS:

If the information in these instructions are not followed exactly, a fire or explosion may result, causing property damage, personal injury or death.

Installation and service must be performed by a qualified installer or service agency.

READ THE ENTIRE MANUAL BEFORE INSTALLING OR USING THIS EQUIPMENT.

The unit uses R-290 gas as the refrigerant. R-290 is flammable and heavier than air. It collects first in low areas but can be circulated by the fans. If propane gas is present or even suspected, do not allow untrained personnel to attempt to find the cause. The propane gas used in the unit has no odor. The lack of smell does not indicate a lack of escaped gas. If a leak is detected, immediately evacuate all persons from the store, and contact the local fire department to advise them that a propane leak has occurred. Do not let any persons back into the store until the qualified service technician has arrived and that technician advises that it is safe to return to the store. No open flames, cigarettes or other possible sources of ignition should be used inside or in the vicinity of the units.

FAILURE TO ABIDE BY THIS WARNING COULD
RESULT IN AN EXPLOSION, DEATH, INJURY AND
PROPERTY DAMAGE.

IMPORTANT

Keep in store for future reference!



Installation & Operation Manual



P/N 3109358_C

October 2024

Spanish 3109361



BEFORE YOU BEGIN

Read these instructions completely and carefully.



PERSONAL PROTECTION EQUIPMENT (PPE)

Personal Protection Equipment (PPE) is required whenever installing or servicing this equipment. Always wear safety glasses, gloves, protective boots or shoes, long pants, and a long-sleeve shirt as required when installing or servicing this equipment.

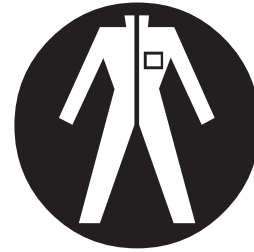
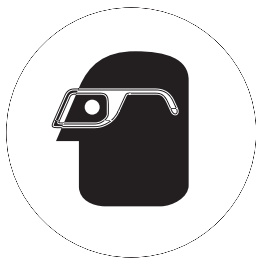

1. If the information in these instructions are not followed exactly, a fire or explosion may result, causing property damage, personal injury or death.
2. Installation and service must be performed by a qualified installer or service agency.
3. This unit is designed only for use with R-290 gas as the designated refrigerant.

THE REFRIGERANT LOOP IS SEALED. ONLY A QUALIFIED TECHNICIAN SHOULD ATTEMPT TO SERVICE!

- Propane is flammable and heavier than air.
- It collects first in the low areas but can be circulated by the fans.
- If R-290 is present or even suspected, do not allow untrained personnel to attempt to find the cause.
- The propane gas used in the unit has no odor.
- The lack of smell does not indicate a lack of escaped gas.
- If a leak is detected, immediately evacuate all persons from the store, and contact the local fire department to advise them that a propane leak has occurred.
- Do not let any persons back into the store until the qualified service technician has arrived and that technician advises that it is safe to return to the store.
- A hand-held propane leak detector (“sniffer”) shall be used before any repair and/or maintenance.
- No open flames, cigarettes or other possible sources of ignition should be used inside the building where the units are located until the qualified service technician and/or local fire department determines that all propane has been cleared from the area and from the refrigeration systems.
- Component parts are designed for propane and non-incendive and non-sparking. Component parts shall only be replaced with identical repair parts.

FAILURE TO ABIDE BY THIS WARNING COULD RESULT IN AN EXPLOSION, DEATH, INJURY AND PROPERTY DAMAGE.

TABLE OF CONTENTS

ANSI Z535.5 DEFINITIONS	iv	START UP / OPERATION	
		Controller Operation	3-1
		Controller Connections	3-2
		Controller LED	3-3
		Controller Buttons	3-4
		Sensor to Control	
		Configuration	3-6
		Controls and Adjustments	3-7
		Load Limits	3-8
		Stocking	3-8
		Solar Thermometer	3-8
		Shelf Maximum Weight Limits	3-9
INSTALLATION		MAINTENANCE	
UL Listing	1-1	Care and Cleaning	4-1
Federal / State Regulation	1-1	Exterior Surfaces	4-1
Husmann Product Control	1-1	Interior Surfaces	4-1
Shipping Damage	1-1	Do NOT Use:	4-1
Apparent Loss Or Damage	1-1	Do:	4-1
Concealed Loss Or Damage	1-1	Cleaning Discharge Honeycomb	4-2
Location	1-1	Cleaning Stainless Steel Surfaces	4-2
Self Contained (Location)	1-2	Cleaning Solar Thermometer	4-2
Model Description	1-2	Cleaning Under Display Pan	4-3
Unloading	1-3	Cleaning Evaporation Pan	4-3
Unloading from Trailer	1-3	Cleaning Coils	4-4
Exterior Loading	1-3	Removing Scratches from Bumper	4-4
Shipping Skid	1-3	Self-Contained Refrigeration Equipment	
Merchandiser Leveling	1-4	Maintenance Check List	4-5
Optional Legs	1-4	SERVICE	
Serial Plate Location	1-4	Replacing Fan Motors and Blades	5-1
Refrigeration Unit Access	1-4	Replacing Evaporation Fan	
Sealing Merchandiser to Floor	1-4	Motors and Blades	5-2
Husmann Self-Contained Refrigeration		Replacing Food Compartment	
Equipment Start Up Check List	1-5	Fan Motors and Blades	5-3
		LED Fixture Replacement	5-4
		Troubleshooting Guide	5-5
		Troubleshooting Light Guide	5-6
		GSVM Accessories	5-6
ELECTRICAL / REFRIGERATION			
Merchandiser Electrical Data	2-1		
Field Wiring	2-1		
Electrical Connections	2-1		
Power Switch	2-1		
Electrical Outlet	2-1		
Refrigeration (Self Contained Models)	2-2		
Waste Outlet and Water Seal	2-2		
Optional Electric Condensate Pan	2-2		
Refrigeration System	2-3		
Service Safety	2-4		
Replacing Refrigeration			
System Components	2-5		
Steps to Recover Refrigerant	2-5		
Charging	2-5		
Waste Outlet and Water Seal	2-6		

IMPORTANT
KEEP IN STORE FOR FUTURE REFERENCE
Quality that sets industry standards!

12999 St. Charles Rock Road • Bridgeton, MO 63044-2483

U.S. & Canada 1-800-922-1919 • Mexico 800-890-2900

www.husmann.com

© 2024 Husmann Corporation

REVISION HISTORY

REVISION C — OCTOBER 2024 Updated cover logos.

REVISION B — FEBRUARY 2020 Added Warning

ORIGINAL ISSUE — FEBRUARY 2020

ANSI Z535.5 DEFINITIONS



• **DANGER** – Indicate[s] a hazardous situation which, if not avoided, will result in death or serious injury.



• **WARNING** – Indicate[s] a hazardous situation which, if not avoided, could result in death or serious injury.



• **CAUTION** – Indicate[s] a hazardous situation which, if not avoided, could result in minor or moderate injury.

• **NOTICE** – *Not related to personal injury* – Indicates[s] situations, which if not avoided, could result in damage to equipment.

ATTENTION

Merchandiser must operate for 24 hours before loading product!

Regularly check merchandiser temperatures.

Do not break the cold chain. Keep products in cooler before loading into merchandiser.

These merchandisers are designed for only pre-chilled products.



WARNING

— LOCK OUT / TAG OUT —

To avoid serious injury or death from electrical shock, always disconnect the electrical power at the main disconnect when servicing or replacing any electrical component. This includes, but is not limited to, such items as doors, lights, fans, heaters, and thermostats.

WARNING

All installation and operating instructions concerning the handling, moving, and use of these merchandisers must be carefully followed to avoid either damaging the refrigerant tubing, or increasing the risk of a leak.

WARNING

Do not use mechanical devices or other means to accelerate the defrosting process.

Do not use electrical appliances inside the food storage compartments of the case.

WARNING

Case ventilation openings must be clear of any obstructions. Do not damage the refrigerant circuit.

INSTALLATION

UL LISTING

These merchandisers are manufactured to meet ANSI/ UL 471 standard requirements for safety. Proper installation is required to maintain the listing.

FEDERAL / STATE REGULATION

These merchandisers at the time they are manufactured, meet all federal and state/ provincial regulations. Proper installation is required to ensure these standards are maintained. Near the serial plate, each merchandiser carries a label identifying the environment for which the merchandiser was designed for use.

ANSI/NSF-7 Type I – Display Refrigerator / Freezer

Intended for 75°F (24°C) / 55%RH Ambient Application

ANSI/NSF-7 Type II – Display Refrigerator / Freezer

Intended for 80°F / 55%RH Ambient Application

ANSI/NSF-7 – Display Refrigerator

Intended for Bulk Produce

GSVM4060 and GSVM4072 are designed to perform to Type II conditions. GSVM 5072 is designed to perform to Type I conditions.

HUSSMANN PRODUCT CONTROL

The serial number and shipping date of all equipment is recorded in Hussmann's files for warranty and replacement part purposes. All correspondence pertaining to warranty or parts ordering must include the serial number of each piece of equipment involved. This is to ensure the customer is provided with the correct parts.

SHIPPING DAMAGE

All equipment should be thoroughly examined for shipping damage before and during unloading. This equipment has been carefully inspected at our factory.

Any claim for loss or damage must be made to the carrier. The carrier will provide any necessary inspection reports and/or claim forms.

Apparent Loss or Damage

If there is an obvious loss or damage, it must be noted on the freight bill or express receipt and signed by the carrier's agent; otherwise, carrier may refuse claim.

Concealed Loss or Damage

When loss or damage is not apparent until after equipment is uncrated, retain all packing materials and submit a written response to the carrier for inspection within 15 days.

Recommended operating ambient temperature is between 65°F (18°C) to 80°F (24°C) for GSVM4060 & GSVM 4072. 65°F (18°C) to 75°F (24°C) for GSVM5272. Maximum relative humidity is 55%.

LOCATION

These merchandisers are designed for displaying products in air conditioned stores where temperature is maintained at or below the ANSI / NSF-7 specified level and relative humidity is maintained at or below 55%.

Placing refrigerated merchandisers in direct sunlight, near hot tables or near other heat sources could impair their efficiency. Like other merchandisers, these merchandisers are sensitive to air disturbances. Air currents passing around merchandisers will seriously impair their operation. Do NOT allow air conditioning, electric fans, open doors or windows, etc. to create air currents around the merchandiser.

1-2 INSTALLATION

SELF CONTAINED (LOCATION)

These models have front condenser air intake and discharge air at the rear of the case. Maintain a minimum clearance distance of two feet in front of the merchandiser so that air intake is not obstructed. Provide a minimum of a 1-inch clearance for air circulation at the rear of the case.

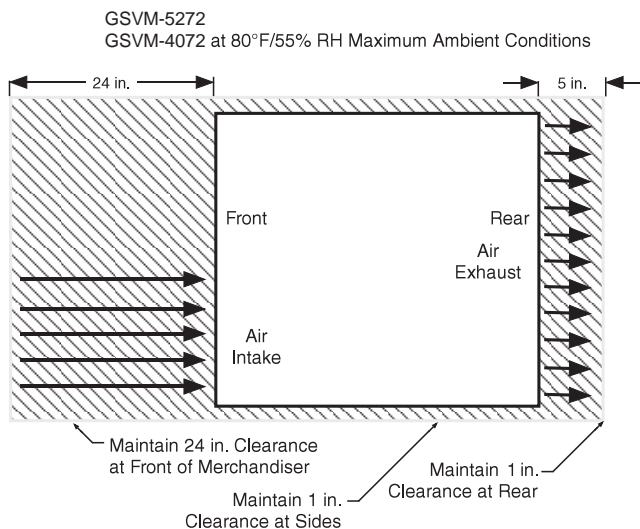

MODEL DESCRIPTION

GSVM-A open vertical merchandisers offer versatility in the display of medium temperature (32° F to 41°F) products such as dairy products, prepared salads, pizza and fresh entrees that are pre-chilled in a cooler. Carefully read and follow the instructions prior to operating the merchandiser.



This warning does not mean that Hussmann products will cause cancer or reproductive harm, or is in violation of any product-safety standards or requirements. As clarified by the California State government, Proposition 65 can be considered more of a 'right to know' law than a pure product safety law. When used as designed, Hussmann believes that our products are not harmful. We provide the Proposition 65 warning to stay in compliance with California State law. It is your responsibility to provide accurate Proposition 65 warning labels to your customers when necessary. For more information on Proposition 65, please visit the California State government website.

UNLOADING

Unloading from Trailer:

Lever Bar (also known as a Mule, Johnson Bar, J-bar, Lever Dolly, or Pry Lever)

Move the merchandiser as close as possible to its permanent location and remove all packaging. Check for damage before discarding packaging. Remove all separately packed accessories such as kits and shelves. Improper handling may cause damage to the merchandiser when unloading to avoid damage:

1. Do not drag the merchandiser out of the trailer. Use a Johnson bar (mule).
2. Use a forklift or dolly to remove the merchandiser from the trailer.



CAUTION

Do not walk or put heavy objects on case.

EXTERIOR LOADING

Do NOT walk on top of merchandisers or damage to the merchandisers and serious personal injury could occur.

MERCHANDISERS ARE NOT STRUCTURALLY DESIGNED TO SUPPORT EXTERNAL LOADING such as the weight of a person. Do not place heavy objects on the merchandiser.

SHIPPING SKID

Each merchandiser is shipped on a skid to protect the merchandiser's base, and to make positioning the case easier.

Do not remove the shipping skid until the merchandiser is near its final location. The skid provides protection for both the merchandiser and the floor.

Remove the skid by raising one end of the merchandiser approximately 6 inches. Block the merchandiser securely, and remove the two skid bolts from the raised end. Replace the bolts with (provided) leg levelers. Repeat this procedure at opposing end. Once the leg levelers are secured in place, the merchandiser may be slid off the skid and placed in its final location.

DO NOT TILT MERCHANDISER ON ITS SIDE OR END WHEN REMOVING SKID.

Once the skid is removed, the merchandiser must be lifted —NOT PUSHED— to reposition.

Check floor where merchandisers are to be set to see if it is a level area. Determine the highest part of the floor.



WARNING

Do NOT remove shipping crate until the merchandiser is positioned for installation.



WARNING

Do NOT stand or walk on top of merchandiser. Do not store items or flammable materials atop the unit.

1-4 INSTALLATION

MERCHANDISER LEVELING

BE SURE TO POSITION MERCHANDISERS PROPERLY. Level the merchandiser by all four corners. Merchandiser(s) must be installed level to ensure proper operation of the refrigeration system, and to ensure proper drainage of defrost water.

OPTIONAL LEGS

NSF® approved legs replace the leg levelers if required by local health codes. The legs raise the case 6 inches for cleaning purposes. An optional skirt kit can be provided to snap on the legs.

SERIAL PLATE LOCATION

The serial plate is located on the interior top, left side of the merchandiser. It contains all pertinent information such as model, serial number, amperage rating, refrigerant type and charge. This information will be needed to install, service or order parts for the merchandiser.



REFRIGERATION UNIT ACCESS

The lower front panel may be removed by removing screw at bottom and lifting the panel straight upward and over the tabs on which it is hanging. The panel is installed by reversing the above procedure.

Ensure lower front panel is flat against the floor when installed to prevent air circulation problems for self contained merchandisers.

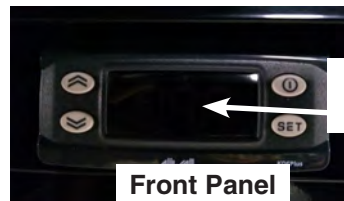

Controller Display

Lift up and out to remove access panel



Display is mounted on left side of access panel. Be careful not to detach cable from display when removing access panel.

SEALING MERCHANDISER TO FLOOR

If required by local sanitary codes, or if the customer desires, merchandisers may be sealed to the floor using a vinyl cove base trim. The size needed will depend on how much variation there is in the floor, from one end of the merchandiser to the other. Sealing of the lower front and rear panels on self contained models may hamper their removal for servicing or maintenance of the condensing unit.

NOTE: Do not allow trim to cover any intake or discharge grilles located in the lower front panel.

Hussmann Self-Contained Refrigeration Equipment Start Up Check List

Please note that failure to follow this start-up document may void your factory warranty

Step	Startup Activity	Check
1	Locate, read and maintain install/operation manual in a safe place for future reference.	<input type="checkbox"/>
2	Examine unit. Confirm there is NO damage or concealed damage.	<input type="checkbox"/>
3	Level the unit, side to side and front to rear.	<input type="checkbox"/>
4	Remove all shipping brackets/compressor straps/bolts etc.	<input type="checkbox"/>
5	Unit must be run on a dedicated electrical circuit without the use of an extension cord.	<input type="checkbox"/>
6	Ensure that the proper electrical requirements for the equipment are supplied.	<input type="checkbox"/>
7	Verify field electrical connections are tight.	<input type="checkbox"/>
8	Verify all electrical wiring is secured and clear of any sharp edges or hot lines.	<input type="checkbox"/>
9	Verify the condensate drain line is properly trapped and pitched.	<input type="checkbox"/>
10	Verify all required clearances on the sides and back of unit.	<input type="checkbox"/>
11	Verify there are no air disturbances external to the unit. Heat and air registers, fans, and doors etc.	<input type="checkbox"/>
Advise owner/operator that merchandiser must operate at temperature for 24 hrs prior to loading with product.		

Form HSCW01 Rev. 30MAY12 P/N 0525209_B

LEGAL DISCLAIMER:

Hussmann shall not be liable for any repair or replacements made without the written consent of Hussmann, or when the product is installed or operated in a manner contrary to the printed instructions covering installation and service which accompanied such product.

1-6 INSTALLATION

NOTES:

ELECTRICAL / REFRIGERATION

MERCHANDISER ELECTRICAL DATA

Refer to Appendix A of this manual or the merchandiser's serial plate for electrical information.

FIELD WIRING

Field wiring must be sized for component amperes stamped on the serial plate. Actual ampere draw may be less than specified.

ALWAYS CHECK THE SERIAL PLATE FOR COMPONENT AMPERES

ELECTRICAL CONNECTIONS

All wiring must be in compliance with NEC and local codes. These models have a factory installed power cord. All electrical connections are to be made in the electrical *Handy Box* located behind the removable base panel at the left end of the merchandiser when facing the discharge air honeycomb.

POWER SWITCH

The main electrical power switch is located behind the front louvered access panel. The power switch must be turned OFF before servicing the merchandiser.

WARNING

**Merchandiser must be grounded.
Do not remove the power supply cord ground.**

ELECTRICAL OUTLET

Before the merchandiser is connected to any wall circuit, use a voltmeter to check that the outlet is at 100% of the rated voltage. The wall circuit must be dedicated for the merchandiser. Failure to do so voids the warranty. Do not use an extension cord. Never plug in more than one merchandiser per electrical circuit.

- Always use a dedicated circuit with the amperage stated on the unit.
- Plug into an outlet designed for the plug.
- Do not overload the circuit.
- Do not use long or thin extension cords. Never use adapters.
- If in doubt, call an electrician.



**NEMA 5-15P
Electrical Plug**

GSVM-A have a factory-installed power cord that is attached at the electrical box.

WARNING

Risk of Electric Shock. If cord or plug becomes damaged, replace only with a cord and plug of the same type.

REFRIGERATION

(Self Contained Models)

Each self contained model is equipped with its own condensing unit and control panel located beneath the display area. The correct type of refrigerant will be stamped on each merchandiser's serial plate. The merchandiser refrigeration piping is leak tested. The unit is factory charged with R-290 refrigerant.

These models have a refrigeration system that uses a hermetic compressor. A capillary tube is used for metering refrigeration flow from the condenser to the evaporator. **If the capillary should become plugged or damaged, it is best to replace the heat exchanger.**

WATER OUTLET AND WATER SEAL

These merchandisers have a water seal that drains into an electric condensate pan, located beneath the merchandiser. The discharge line runs to the evaporation pan in order to cool down discharge line temperature and to gain capacity and improve efficiency.

The pan uses an SS Relay that modulates water inside the pan, adjusting the amount of heat required to evaporate the water .

Ensure the drain hose is properly trapped, and the drain area is not clogged.

NOTE: All lower base panels must be in place when the refrigerator is operating. If not, airflow from the condenser will be directed over the evaporator pan and defrost water in the pan may overflow.



WARNING

— LOCK OUT / TAG OUT —

To avoid serious injury or death from electrical shock, always disconnect the electrical power at the main disconnect when servicing or replacing any electrical component. This includes, but is not limited to, such items as doors, lights, fans, heaters, and thermostats.

REFRIGERATION SYSTEM

(Views below show slide out refrigeration system)

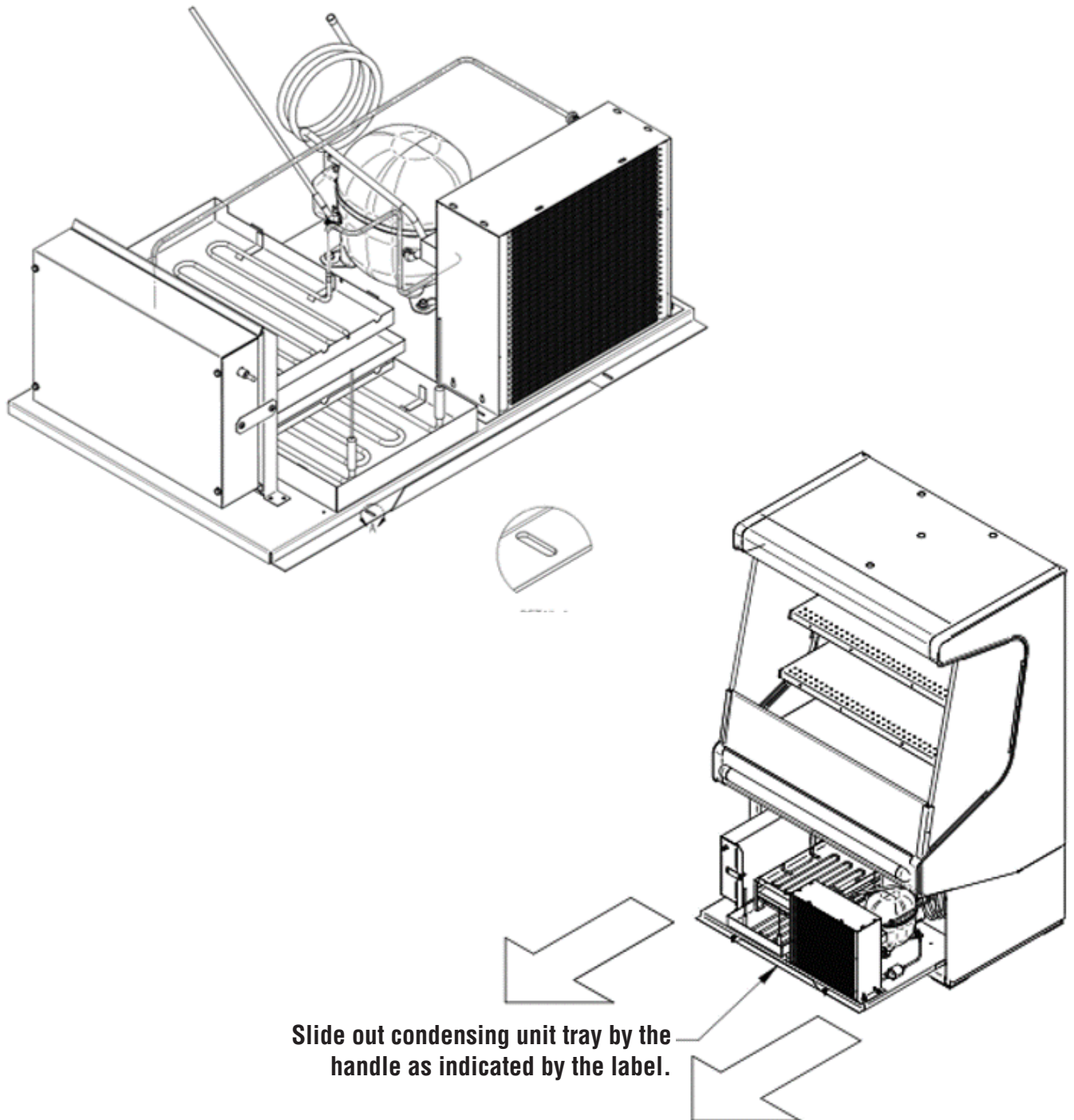

Before Beginning Any Service or Repair:

Use a hand-held propane leak detector (“sniffer”) to ensure no propane is present in the immediate area, the inside of the display case and the inside of the refrigeration system. R-290 is an odorless refrigerant. Keep the area clear of all customers and non-essential or unauthorized personnel.

Verify that all repair parts are identical models to the ones they are replacing. Do not substitute parts such as motors, switches, relays, heaters, compressors, power supplies or solenoids. Failure to do so can result in an explosion, death, injury and property damage. Parts used on hydrocarbon cases must meet specific UL certification for non-incendive or non-sparking components. Use only Hussmann approved parts approved through the Hussmann Performance Parts Website. <https://parts.hussmann.com/>

Brazing must not begin before all propane has been cleared from the immediate area — the inside of the displays case and the inside of the refrigeration system.

! WARNING
Only Hussmann or factory trained technicians should service or repair this R-290 (propane) equipment.
Failure to follow instructions can result in an explosion, death, injury and property damage.

If a leak is detected, follow store safety procedures. It is the store’s responsibility to have a written safety procedure in place. The safety procedure must comply with all applicable codes such as local fire department’s codes.

At minimum, the following actions are required:

- Immediately evacuate all persons from the store, and contact the local fire department to advise them that a propane leak has occurred.
- Call Hussmann and/or a qualified service agent and inform them that a propane sensor has detected the presence of propane.
- Do not let any persons back into the store until the qualified service technician has arrived and that technician advises that it is safe to return to the store.

- The propane gas used in the unit has no odor. The lack of smell does not indicate a lack of escaped gas.
- A hand-held propane leak detector (“sniffer”) should be used before any repair and/or maintenance is attempted. All repair parts must be identical models to the ones they are replacing.
- No open flames, cigarettes or other possible sources of ignition should be used inside the building where the units are located until the qualified service technician and/or local fire department determines that all propane has been cleared from the area and from the refrigeration systems.

REPLACING REFRIGERATION SYSTEM COMPONENTS



DANGER

Only Hussmann service technicians or technicians qualified to handle R-290 (propane) refrigerant should service or repair this R-290 (propane) equipment. Failure to follow instructions can result in an explosion, death, injury and property damage.

7. Pull vacuum to a minimum of 200 microns or lower.



STEPS TO RECOVER REFRIGERANT

1. Make sure you are in a well ventilated area before making any service or repair to the refrigeration system.
2. Disconnect all power sources from the system. Some systems may have more than one plug or power supply.
3. Tap system with line tap valves, attaching gauges to the high and low sides of the system.



**refrigeration
line tapping
valve**

4. Connect hose to an evacuated recovery tank. Open refrigeration gauges and recovery tank.
5. With the suction valve in vacuum, the refrigerant will be recovered into the recovery tank.
6. Once recovered, close the tank valve and remove the gauge from the tank and connect nitrogen tank to the system to purge it with nitrogen.

CHARGING

A calibrated scale with +/-2 gram accuracy must be used to charge the system. The charge amount is shown on the serial plate. Only R-290 grade refrigerant can be used. Standard propane does not meet the purity/moisture content of R-290, and therefore cannot be used to charge cases.

No gas charge adjustments are allowed. When connecting hoses between the refrigeration system, manifold gauges, and refrigerant cylinder, ensure that the connections are secure and there are no potential sources of ignition nearby. Ensure that contamination of different refrigerants does not occur when using charging equipment.



WARNING

— LOCK OUT / TAG OUT —

To avoid serious injury or death from electrical shock, always disconnect the electrical power at the main disconnect when servicing or replacing any electrical component. This includes, but is not limited to, such items as doors, lights, fans, heaters, and thermostats.

Use dedicated hoses to service R-290 (propane) refrigeration systems. Hoses or lines should be as short as possible to minimize the amount of refrigerant contained in them.

Ensure that the refrigeration system is properly grounded prior to charging the system with refrigerant, to avoid the potential for static build-up.



WARNING

Component parts shall be replaced with like components, and servicing shall be done by factory authorized service personnel only, so as to minimize the risk of possible ignition due to incorrect parts or improper service.

Extreme care must be taken not to overfill the refrigeration system. After charging, carefully disconnect the hoses, attempting to minimize the quantity of refrigerant released. Further leak check the service ports, hoses, refrigerant tanks. The service ports shall be checked for leaks using a hydrocarbon leak detector with a sensitivity of 3 grams/year (0.106 Oz/year) leak rate.

Thoroughly leak check the service ports. If no leak is present, use a pinch-off tool to close the ends of the service tubes before brazing them shut. Remove all service ports. If a Schrader valve is used on the compressor service tube, it must be removed and the previous steps followed in order to braze the service tube shut.

WATER OUTLET AND WATER SEAL

The condensate water outlet is located in the center of the merchandiser. The outlet has a factory installed, external water seal.

For self contained models, this water seal drains into the condensate evaporator pan located beneath the merchandiser. The pan uses a thermistor that senses water in the pan and adjusts the amount of heat required to evaporate the water. **Ensure the drain hose is properly trapped, and the drain area is not clogged.**

NOTE: All lower base panels must be in place when the refrigerator is operating. If not, air-flow from the condenser will be directed over the evaporator pan and defrost water in the pan may overflow.



WARNING

Refrigeration lines are under pressure. Refrigerant must be recovered before attempting any connection or repair.



START UP / OPERATION

CONTROLLER OPERATION

The electronic controller is located in the cassette compartment. The controller comes factory set, and is ready for use. The front grille must be removed in order to access this control.

When removing the grille for this operation or for condenser cleaning, care must be taken not to damage the display interface cable. It may be unplugged during this task.

1. Plug the merchandiser plug into its receptacle.
 - a. The controller display will illuminate.
 - b. The interior light will illuminate.
2. After the control preprogrammed time delay of up to 6 minutes, the compressor and evaporator fan(s) will start if the control is calling for cooling.
3. The control will cycle the compressor but may also cycle evaporator fan(s) on and off determined by the Set-Point and Differential temperatures.
 - a. The Set-Point is the adjustable preprogrammed temperature.
 - b. The Differential is the non-adjustable preprogrammed temperature.
 - c. The Control is designed to read and display a cabinet temperature not a product temperature.

This cabinet temperature may reflect the refrigeration cycle of the Set-Point and it's Differential. The most accurate temperature on a cabinets operation is to verify the product temperature.

Main Features:

- Panel-mounted
- Energy saving algorithms and optimised defrost control
- 8 preloaded applications
- Defrost at single / double evaporator
- Frame Heater
- Local network auto-configuration
- Direct load connection (up to 2 HP)
- Supply voltage control LVD
- Presence of an open collector output



DISPLAY CONTROL



CONNECTIONS

TERMINALS

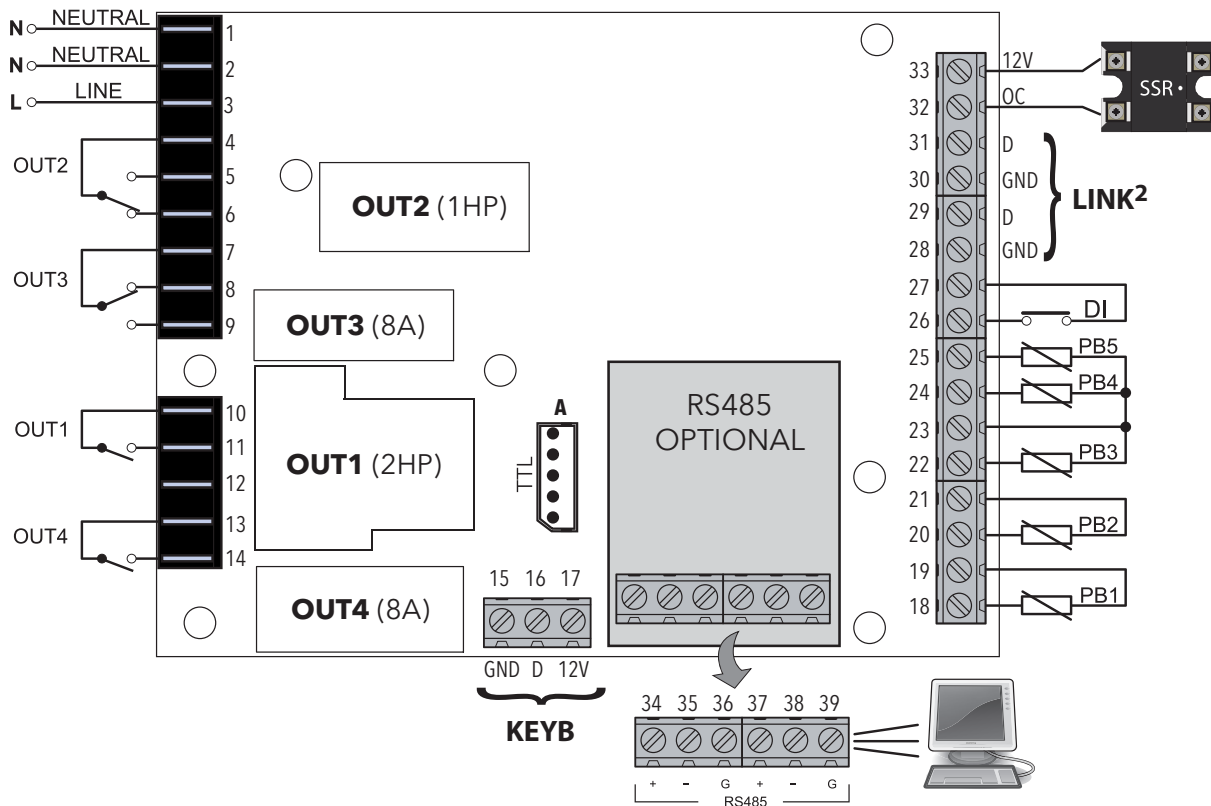

* **N.B.:** analogue inputs PB1...PB5 can also be configured as Digital Inputs DI.

TERMINALS			
1-2	NEUTRAL. These are power supply terminals.	15-16-17	Connection to KDEPlus or KDWPlus external keyboard or ECPlus echo module.
3	LINE. These are power supply terminals.	19-18	PB1 probe connection.
4	OUT2 Shared Terminal	21-20	PB2 probe connection.
5	N.O. OUT2	23-22	PB3 probe connection.
6	N.C. OUT2	23-24	PB4 probe connection.
7	OUT3 Shared Terminal	23-25	PB5 probe connection.
8	N.C. OUT3	27-26	Digital input (DI).
9	N.O. OUT3	28-29	LINK ² . Connection 1 - local area network.
10	OUT1 Shared Terminal	30-31	LINK ² . Connection 2 - local area network.
11	N.O. OUT1	32-33	Open Collector Output (OC).
12	Not Used	A	TTL Unicard/DMI/Multi Function Key connection
13	OUT4 Shared Terminal	34-35-36	RS485. Connection 1 - Supervision Gateway.
14	N.O. OUT4	37-38-39	RS485. Connection 2 - Supervision Gateway.

LED

RTN400 family controllers will also function even if a keyboard has not been connected.

With **KDEPlus** or **KDWPlus** keyboards (which are the same and guarantee the same functions), the display will be as follows:

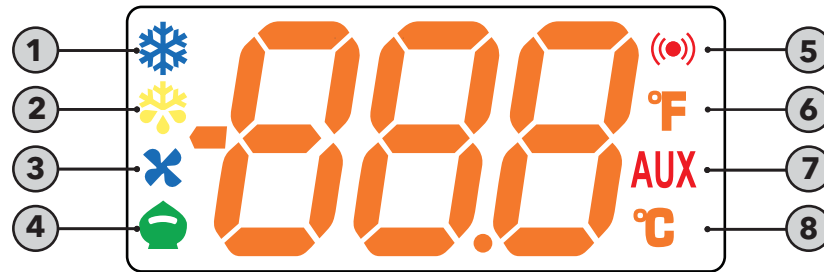

Meaning of LEDs:

No	Icon	LED	Operation	Meaning
1		Compressor	Permanently on	compressor on
			Blinking	Delay, protection or start-up blocked
			OFF	otherwise
2		Defrost	Permanently on	Defrost active
			Blinking	Activated manually or from Digital Input
			OFF	otherwise
3		Fans	Permanently on	Fans active
			OFF	otherwise
4		Reduced SET / Economy	Permanently on	Energy Saving active
			Blinking	Reduced setpoint active
			OFF	otherwise
5		Alarm	Permanently on	alarm active
			Blinking	Alarm acknowledged
			OFF	otherwise
6		°F readout	Permanently on	°F setting (dro = 1)
			OFF	otherwise
7	AUX	AUX	Permanently on	Aux output active and/or light on
			Blinking	Deep cooling on
			OFF	otherwise
8		°C readout	Permanently on	°C setting (dro = 0)
			OFF	otherwise

N.B.: When the instrument is powered on it performs a lamp test, during which time the display and LEDs will flash for several seconds to check that they all function correctly.

KDEPLUS BUTTONS

The **KDEPlus** keyboard has 4 keys, as shown in the illustration:

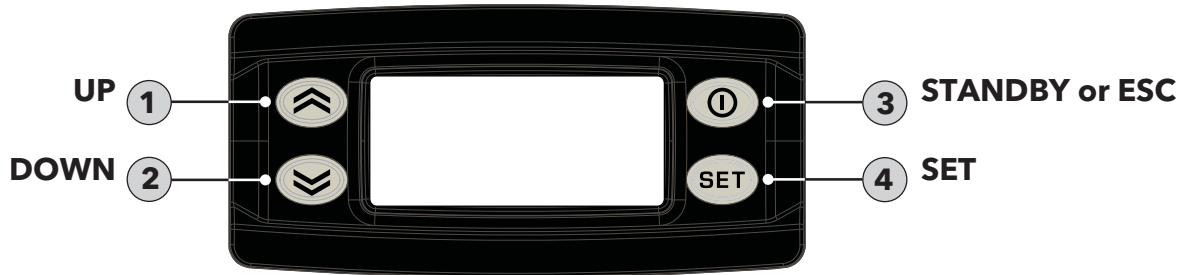





Each key has a different function depending on whether it is:

- Pressed and released
- Pressed for at least 5 seconds
- Pressed and held at start-up
- Pressed in combination with another key.

KEYS

The following table summarizes the function of each key:

No	Key	Action		
		Pressed and released	Press for at least 5 secs	Start-up
1		<ul style="list-style-type: none"> • Scrolls through menu items • Decreases values 	Activates the Manual Defrost function (from outside menus).	---
2		<ul style="list-style-type: none"> • Scrolls through menu items • Decreases values 	Function can be configured by the user (from outside menus). (see parameter H32)	---
3		<ul style="list-style-type: none"> • Returns to the previous menu level • Confirms parameter value 	Activates the Stand-by function (from outside menus).	---
4		<ul style="list-style-type: none"> • Displays any alarms (if active) • Opens Machine Status menu • Confirms commands 	Opens the Programming Menu (User and Installer parameters)	When pressed during start-up it enables the user to select the application to be loaded.

SETPOINT: SETTING AND EDIT LOCK

To display the Setpoint value, press the **set** key to enter the "Machine Status" menu, then press the **set** key again when the "SEt" label is displayed.

The Setpoint value appears on the display. To change the Setpoint value, press the **UP** and **DOWN** keys within 15 seconds. Press **set** to confirm the modification.

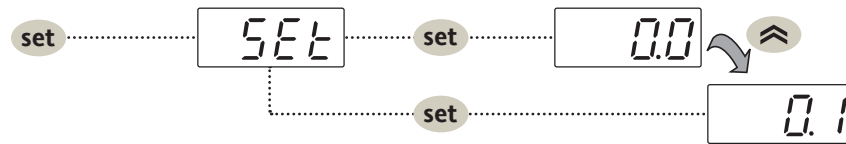

It is possible to disable the keypad on this device.

The keypad can be locked by programming the "LOC" parameter appropriately.

With the keypad locked, you can still access the "Machine Status" menu by pressing **set** to display the Setpoint, but you cannot edit it. To disable the keypad lock, repeat the locking procedure.

DISPLAY PROBES VALUE

To display the value read by probes connected to the device, press the **set** key and enter the "Machine Status" menu, then press the key again when one of the probe-related labels "Pb1...Pb5" press the **set** key again. The value measured by the associated probe will appear on the display.

NOTE: The displayed value is read-only and cannot be modified.

KDEPLUS BUTTONS

The **KDEPlus** keyboard has 4 keys, as shown in the illustration:



KEY-ACTIVATED FUNCTIONS

All models have the **UP** key set to enable the "Manual Defrost" function.

The DOWN and ESC keys can also be set to activate any other function required by the user.

The parameters for configuring the two keys are:

- **H11** = DOWN key configuration
- **H33** = ESC key configuration

The values that can be set apply to both keys and the functions that can be activated are:

H32/H33 value	Function to enable
0	disabled
1	defrost
2	reduced set
3	Light
4	Energy saving
5	AUX
6	Stand-by
7	Deep cooling cycle
8	Start/end defrost

3-6 ELECTRICAL / REFRIGERATION

Sensor to Control Configuration

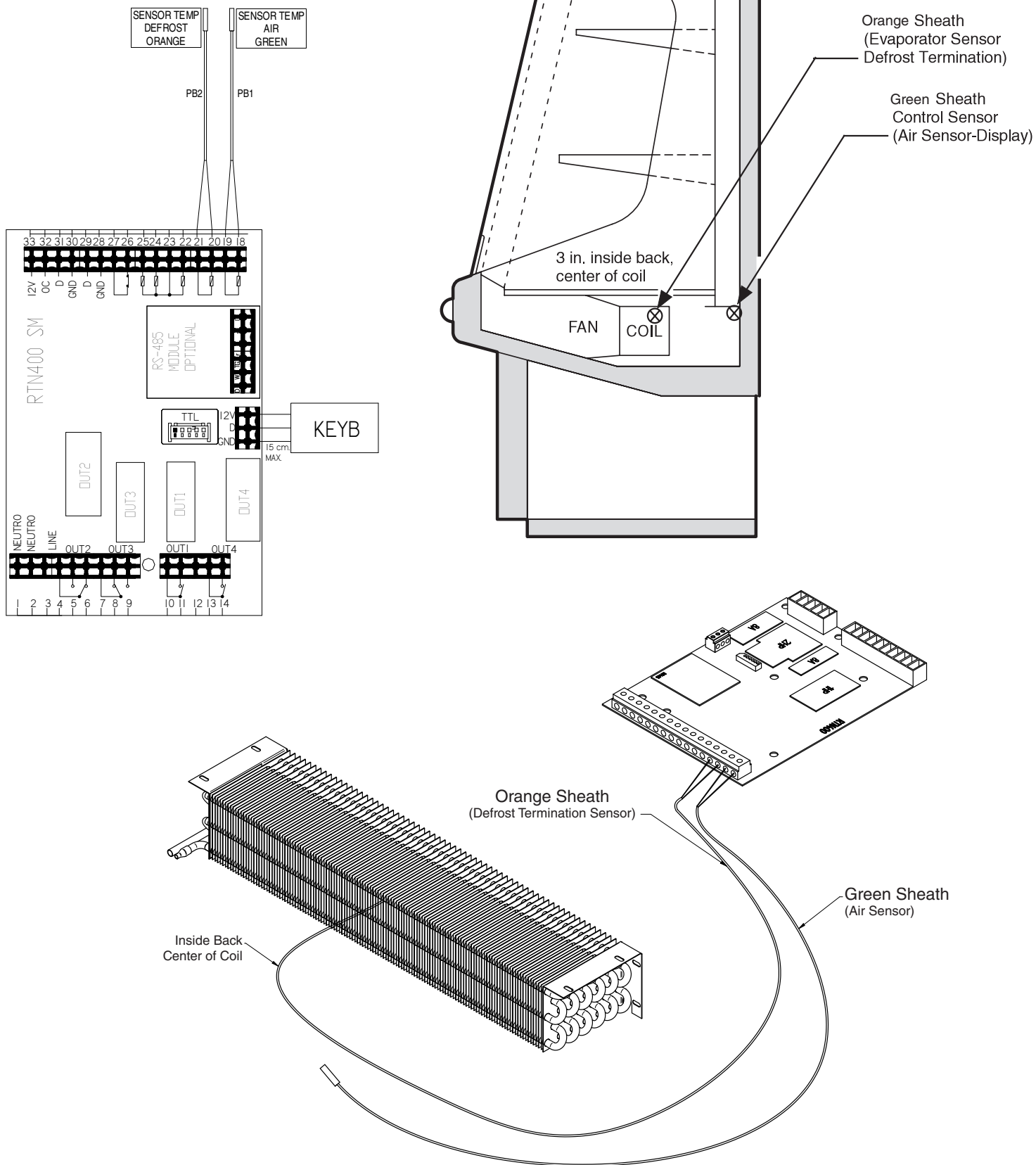

CONTROLS and ADJUSTMENTS

Refrigeration Controls			Defrost Controls			
Model	Product Application	Discharge Air Temperature	Defrost Frequency (per day)	Type of Defrost	Temp. Termination	Failsafe Time (Minutes)
GSVM-4060A Self Contained	Medium Temp. (Dairy, Deli)	25° - 28° F (-3.8° to -2° C)	3	Off Time	48°F	45
GSVM-4072A Self Contained	Medium Temp. (Dairy, Deli)	27° - 30° F (-2.7° to -1.1° C)	3	Off Time	48°F	45
GSVM-5272A Self Contained	Medium Temp. (Dairy, Deli)	31° - 34° F (-0.5° to -1.1° C)	3	Off Time	48°F	45

The controller controls refrigeration temperature. This is factory installed in the control panel. Adjust the control to maintain the discharge air temperature shown.

The factory defined setpoint is required to comply with energy regulations such as from the Department of Energy (DOE). If for some reason, colder temperatures are required for customer specific products the setpoint can be adjusted.

Discharge air temperatures should be measured at the center of the discharge honeycomb.

Defrosts are time initiated and temperature terminated. The defrost setting is factory set as shown above.

To ensure a thorough defrost, defrost must be terminated by the temperature termination setting — not by time.

The chart shown in the figure above describes the operation of GSVM-A models under ambient conditions that do not exceed 75°F and Relative Humidity of 55%.

For the GSVM-A models, the controller parameters defined from the factory has a temperature differential of 19°F. Assuming Set-Point is 21°F and the Differential is 19°F. (Set-Point) 21°F + 19°F (Differential) = 40°F. The compressor will cycle off 21°F and back on at 40°F.

LOAD LIMITS

Each merchandiser has a load limit decal. Shelf life of perishables will be short if load limit is violated.

AT NO TIME SHOULD MERCHANDISERS BE STOCKED BEYOND THE LOAD LIMITS INDICATED.

DO NOT BLOCK AIR LOUVERS.



STOCKING

Product should NOT be placed inside the merchandisers until merchandisers are at proper operating temperature.

Allow merchandiser 24 hours to operate before loading product.

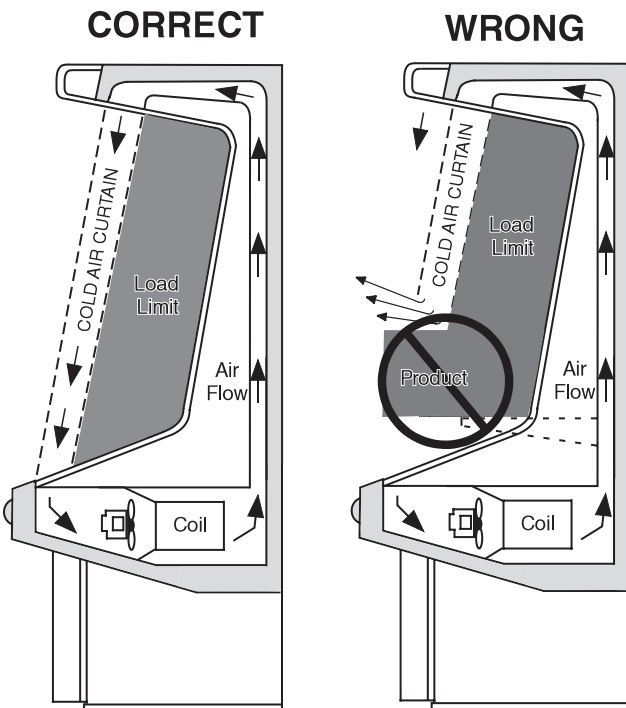

Do not stock product past shelves

WARNING

Product will be degraded and may spoil if allowed to sit in a non-refrigerated area.

Proper rotation of product during stocking is necessary to prevent product loss. Always bring the oldest product to the front and set the newest to the back.

AIR DISCHARGE AND RETURN FLUES MUST REMAIN OPEN AND FREE OF OBSTRUCTION AT ALL TIMES to provide proper refrigeration and air curtain performance. Do not allow product, packages, signs, etc. to block these grilles. Do not use non-approved shelving, baskets, display racks, or any accessory that could hamper air curtain performance.

Do not allow product to be placed outside of the designated load limits in the illustration at left. Air flows through the back wall, over the product on the shelves, across the face of the product (air curtain), and into the return air grille.

SOLAR THERMOMETER

GSVM-A models have solar thermometers. The thermometer is located at the top, front center of the merchandiser's cabinet interior.

Temperature is displayed in Fahrenheit degrees as a standard option. Celsius is also an available option. The thermometer may be replaced if it becomes damaged.

To replace: remove the two screws securing the thermometer to its mounting bracket. Remove the sensing element from the clip, and install the new thermometer in reverse order.

SHELF MAXIMUM WEIGHT LIMITS

Husmann merchandiser shelves are designed to support the maximum weight load limits as indicated in the table below.

Exceeding these maximum weight load limits may cause damage to the shelf or shelves, damage to the merchandiser, damage to store products, and potentially create a hazardous condition for customers and staff. Exceeding the indicated maximum weight load limits constitutes misuse as described in the Husmann Limited Warranty.

GSVM-4060A has two standard shelves for product display. The 13 in. shelf should be positioned above the 15 in. shelf. Models GSVM-5272A and GSVM-4072A have an additional standard 13 in. shelf that is also to be positioned above the 15 in. shelf.

Maximum Shelf Weight Limits

	¹ Flat	17° Tilt	30° Tilt
Bottom Sheet Metal Area	250 lb (113.4 kg)	N/A	N/A
Standard 13 in. (330 mm) Shelf	250 lb (113.4 kg)	250 lb (113.4 kg)	75 lb (34 kg)
Standard 15 in. Shelf w/ optional 6° adapters	125 lb (56.7 kg)	N/A	N/A
Optional Wire Baskets	200 lb (90.7 kg)	100 lb (35.4 kg)	30 lb (13.6 kg)

¹ Shelf load limits at 0° tilt

3-10 STARTUP / OPERATION

NOTES:

MAINTENANCE



WARNING

To reduce the risk of fire, electrical shock or injury when cleaning this merchandiser:

- **Unplug the merchandiser before cleaning;**
- **Keep all liquids away from electrical and electronic components;**
- **Do not use any mechanical device or other means to speed the defrost process, except as recommended by the manufacturer.**

CARE AND CLEANING

Long life and satisfactory performance of any equipment is dependent upon the care it receives. To ensure long life, proper sanitation and minimum maintenance costs, these merchandisers should be thoroughly cleaned, all debris removed and the interiors washed down, weekly.

Exterior Surfaces

The exterior surfaces must be cleaned with a mild detergent and warm water to protect and maintain their attractive finish. **NEVER USE ABRASIVE CLEANSERS OR SCOURING PADS.**

Interior Surfaces

The interior surfaces may be cleaned with most domestic detergents, ammonia based cleaners and sanitizing solutions with no harm to the surface. Self contained models empty into a limited capacity evaporation pan, which will overflow if excess water is used in cleaning.

DO NOT Use:

Abrasive cleansers and scouring pads, as these will mar the finish or coarse paper towels on coated glass. **DO NOT** use ammonia-based cleaners on acrylic parts.

Solvent, oil or acidic based cleaners on any interior surfaces.

Do not use high pressure water hoses.

DO NOT flood merchandiser with water. **NEVER INTRODUCE WATER FASTER THAN THE WASTE OUTLET CAN REMOVE IT.**

Self contained models empty into an evaporation pan that will overflow if too much water is introduced during cleaning.

Do Use:

Remove the product and all loose debris to avoid clogging the waste outlet. Store product in a refrigerated area such as a cooler. Remove only as much product as can be taken to the cooler in a timely manner.



WARNING

Product will be degraded and may spoil if allowed to sit in a non-refrigerated area.

Disconnect electrical power before cleaning.

Thoroughly clean all surfaces with soap and hot water. **DO NOT USE STEAM OR HIGH WATER PRESSURE HOSES TO WASH THE INTERIOR. THESE WILL DESTROY THE MERCHANDISERS' SEALING CAUSING LEAKS AND POOR PERFORMANCE.**

Lift hinged fan plenum for cleaning. Hook chain in rear panel to secure plenum during cleaning. Be sure to reposition the fan plenum after cleaning merchandiser. Take care to minimize direct contact between fan motors and cleaning or rinse water.

Allow merchandisers to dry before resuming operation. After cleaning is completed, turn on power to the merchandiser.



WARNING

— LOCK OUT / TAG OUT —

To avoid serious injury or death from electrical shock, always disconnect the electrical power at the main disconnect when servicing or replacing any electrical component. This includes, but is not limited to, such items as doors, lights, fans, heaters, and thermostats.

CLEANING DISCHARGE HONEYCOMB

Discharge air honeycombs should be cleaned every six months. Dirty honeycombs will cause merchandisers to perform poorly. The honeycombs may be cleaned with a vacuum cleaner. Soap and water may be used if all water is removed from the honeycombs cells before replacing. Be careful not to damage the honeycombs.

1. Using a flat object such as a screw driver, compress the honeycomb and remove it from its retainer.
2. Clean and dry the air honeycombs.
3. After cleaning, replace in reverse order. Damaged honeycombs must be replaced.



CAUTION

DO NOT FLOOD!

Use only enough water necessary to clean surface. Water must not drip down the case!

Never use ammonia based cleansers, abrasive cleansers, or scouring pads.

CLEANING STAINLESS STEEL SURFACES

Use non-abrasive cleaning materials, and always polish with grain of the steel. Use warm water or add a mild detergent to the water and apply with a cloth. Always wipe rails dry after wetting.

Use alkaline chlorinated or non-chlorine containing cleaners such as window cleaners and mild detergents. Do not use cleaners containing salts as this may cause pitting and rusting of the stainless steel finish. Do not use bleach.

CLEANING SOLAR THERMOMETER

GSVM models have solar thermometers. The thermometer is located at the top, front center of the merchandiser's cabinet interior.

To clean the thermometer:

1. Remove the two screws securing the thermometer to its mounting bracket. Remove the sensing element from the clip
2. Use non-abrasive cleaning materials and a mild detergent to clean thermometer.
3. Be sure to wipe the element clean of any residues.



CAUTION

Do NOT use HOT water on Cold glass Surfaces. This can cause the glass to shatter and could result in personal injury. Allow glass fronts, to warm before applying hot water.

CLEANING UNDER DISPLAY PAN

Remove all product from the merchandiser and place in cooler. Always disconnect electrical power before cleaning.

1. Remove the display pan.
2. Use non-abrasive cleaning materials and a mild detergent to clean display pan.
3. Wipe down the insides of the merchandiser with a mild detergent, and replace display pan. Allow merchandiser to pull down in temperature before loading product.

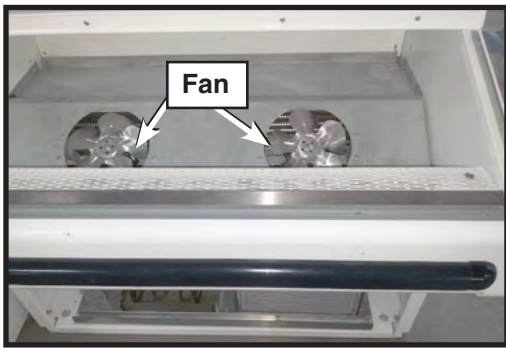

Merchandiser with Display Pan removed



**PRECAUTION
CLEANING PRECAUTIONS**

When Cleaning:

- Do not use high pressure water hoses
- Do not introduce water faster than waste outlet can drain
- NEVER INTRODUCE WATER ON SELF CONTAINED UNIT WITH AN EVAPORATION PAN
- NEVER USE A CLEANING OR SANITIZING SOLUTION THAT HAS OIL BASE (these will dissolve the butyl sealants) or an AMMONIA BASE (this will corrode the copper components of the merchandiser)
- TO PRESERVE THE ATTRACTIVE FINISH:
- Use a water and a mild detergent for the exterior only
- Do NOT use a chlorinated cleaner on any surface
- Do NOT use abrasives or steel wool scouring pads (these will mar the finish)

CLEANING EVAPORATION PAN

GSVM-4060A GSVM-4072A/5272A (STANDARD)

The condensate water outlet for self contained models empties into a limited capacity evaporation pan.

Debris or dirt accumulation inside the condensate evaporation pan or on the heater coil will reduce the pan's evaporation capacity and cause premature heater failure. The evaporation pan waste water will overflow and spill onto the floor if the heater is not properly operating.

Remove accumulated debris from the evaporation pan. Wipe down heater coil with a cloth and warm water. Be sure to remove any dirt, debris or liquids from the heater coil.

Water introduced during cleaning will cause the evaporation pan to overflow.

! WARNING

**Evaporation Pan is Hot!
and poses risk of bodily injury – Always
Wear gloves and protective eye wear when
servicing. Turn off evaporation pan heater,
and allow pan to cool.**

! WARNING

**SHUT FANS OFF DURING
CLEANING PROCESS.**

CLEANING COILS

Condenser coils should be cleaned at least once per month. Additional cleaning may be needed depending on the operational environment. A dirty condenser blocks normal airflow through the coils.

Airflow blockage increases energy consumption and reduces the merchandiser's ability to maintain operating temperature.

To clean the coils, use a vacuum cleaner with a wand attachment and a soft (non-metallic) brush to remove dirt and debris. Do not bend coil fins. Always wear gloves and protective eye wear when cleaning near sharp coil fins and dust particles.



NEVER USE SHARP OBJECTS AROUND COILS. Use a soft brush or vacuum brush to clean debris from coils. ***Do not puncture coils!*** Do not bend fins. Contact an authorized service technician if a coil is punctured, cracked, or otherwise damaged.

ICE in or on the coil indicates the refrigeration and defrost cycle is not operating properly. Contact an authorized service technician to determine the cause of icing, and to make adjustments as necessary. To maintain product integrity, move all product to a cooler until the unit has returned to normal operating temperatures.

REMOVING SCRATCHES FROM BUMPER

Most scratches and dings can be removed using the following procedure.

1. Use steel wool to smooth out the surface area of the bumper.
2. Clean area.
3. Apply vinyl or car wax and polish surface for a smooth glossy finish.

Self-Contained Refrigeration Equipment Maintenance Check List

***** Warranty does not cover issues caused by improper installation or lack of basic preventative maintenance. *****	
Record starting date	
Store Name and Number	
Store Address	
Unit Model Number	
Unit Serial Number	
Contractor/Technician	

	Technician		Q1	Q2	Q3	Q4	Q1	Q2	Q3	Q4
	PM date									
PM activity-For visual inspection items, denote "ok or complete" in the column to the right when PM has been performed. For measured data requested, record data requested in the appropriate column to the right)	Quarterly	Semi-Annually								
Check in with store manager, record any complaints or issues they have with unit.	X									
Look unit over for any damage, vibrations or abnormal noise.	X									
Verify unit is level side to side and front to rear.	X									
Confirm refrigerant lines properly are secured and not touching or rubbing other lines, wires or frame work.	X									
Verify fan motors and motor mounts are tight.	X									
Confirm fan blade/s are tight and not rubbing or hitting.	X									
Make sure all electrical connections, factory and field, are tight.	X									
Verify electrical connections at lamps are they secure and dry.	X									
Check for and replace any frayed or chaffed wiring.	X									
Check all electrical wiring make sure it is secured and not on any sharp edges or hot lines.	X									
Check for air disturbances external to the unit. Heat and air registers, fans, and doors etc.	X									
Check for water leaks.	X									
Clean evaporator coil/s and fan blade/s. Do not use an acid base cleaner. Rinse off any cleaner residue.		X								
Clean discharge air honeycombs or grilles. Do not use an acid base cleaner. Rinse off any cleaner residue.		X								
Clean condenser coil/s and fan blade/s. Do not use an acid base Cleaner. Rinse off any cleaner residue.		X								
Clean condensate drain pan and drain line.		X								
Verify condensate drain lines are clear and functioning.		X								
Record voltage reading at unit with unit off?		X								
Verify condenser and evaporator fans are working.	X									
Record condenser air inlet temperature	X									
Record condenser air outlet temperature	X									
Is condenser air inlet or air exhaust restricted or recirculating?	X									
Verify there are no visual oil or refrigerant leaks.	X									
Record voltage reading with unit running.		X								
Record compressor amp draw.		X								
Record defrost heater voltage and amp draw.		X								
Record anti-sweat heater voltage and amp draw.		X								
Record case product temperature.	X									
Record unit discharge air temperature.	X									
Record unit return air temperature.	X									
Record ambient conditions around unit (wet Bulb temperature and dry bulb temperature).	X									
Check product loading, do not load beyond the units load limits.	X									
Verify clearances on sides/back of unit.	X									
Check unit controller for proper operation. See controller or 1/0 Manual for proper controller operation.		X								
Confirm door switches function.	X									
Verify unit doors and lids work and are sealed correctly.	X									
Verify that all the panels, shields and covers are in place.	X									

Technician Notes:

4-6 MAINTENANCE

NOTES:

SERVICE

REPLACING FAN MOTORS AND BLADES

Should it ever be necessary to service or replace the fan motors or blades be certain that the fan blades are reinstalled correctly.

The blades must be installed with raised embossing (part number on plastic blades) positioned as indicated on the parts list.

For access to these fans:

1. Remove product and place in a refrigerated area. Turn off power to the merchandiser.
2. Make sure there is no voltage in the refrigerator. Remove front grille to have access to the machine compartment.
3. Remove condensing unit screws. (Fig A).
4. Slide out the condensing unit (Fig B). Be careful using the condensing unit plate to pull out the condensing unit. Make sure not to stress or interfere with other parts.
5. Disconnect condenser motor harness.
6. Release screws to remove condenser fan assembly (Fig. C).
7. Release motor screws to get to motor / blade assembly (Fig. D).
8. Change the failed part.
9. If the only damaged part is the motor, remove blade.
10. Reverse the process and make sure everything is in place.

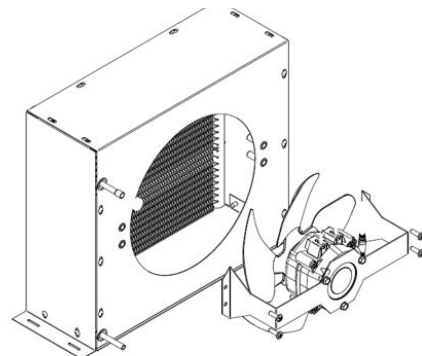
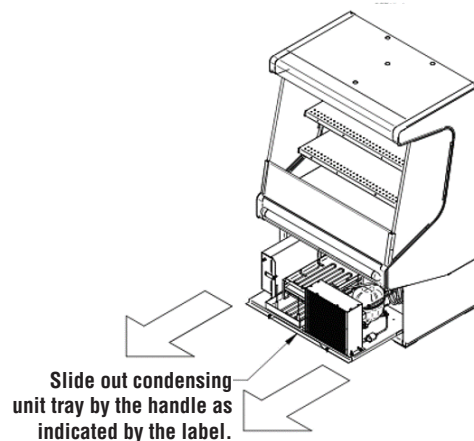
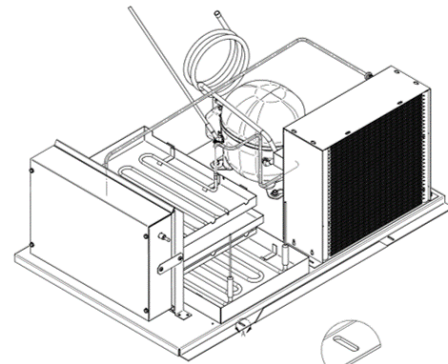

Figure C . Condenser fan bracket screws

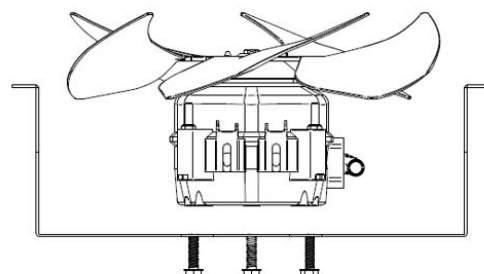

Figure D . Condenser fan motor screws

REPLACING EVAPORATION PAN HEATER

For access to these fans:

1. Remove product and place in a refrigerated area. Turn off power to the merchandiser.
2. Make sure there is no voltage in the refrigerator.
3. Remove front grille to access the machine compartment.
4. Remove condensing unit screws (Fig. A).
5. Slide out the condensing unit (Fig. B). Be careful using the condensing unit plate to pull out the condensing unit. Make sure to not stress other parts.
6. Disconnect heater from control box.
7. Remove heater clips to allow heater to be removed (Fig. C).
8. Change the failed heater.
9. Reverse the process and make sure everything is in place.

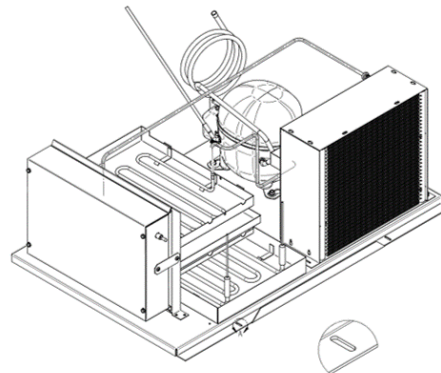

Figure A . Condensing Unit Screws

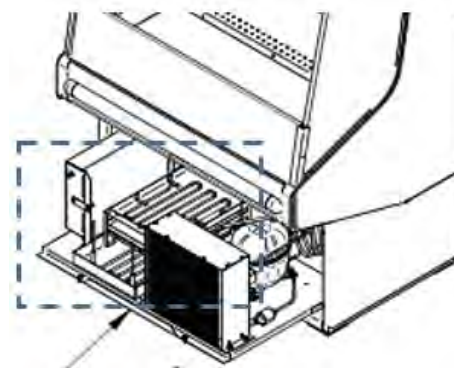

Figure B. Point to pull out condensing unit

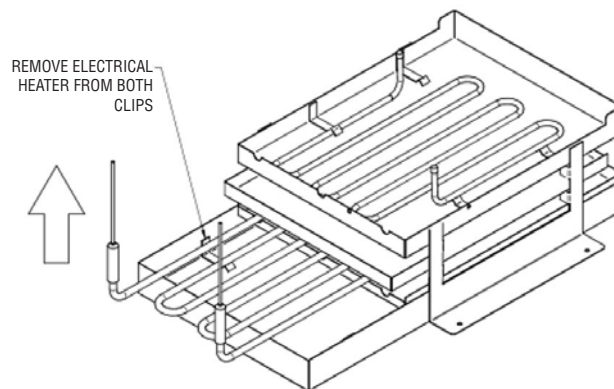
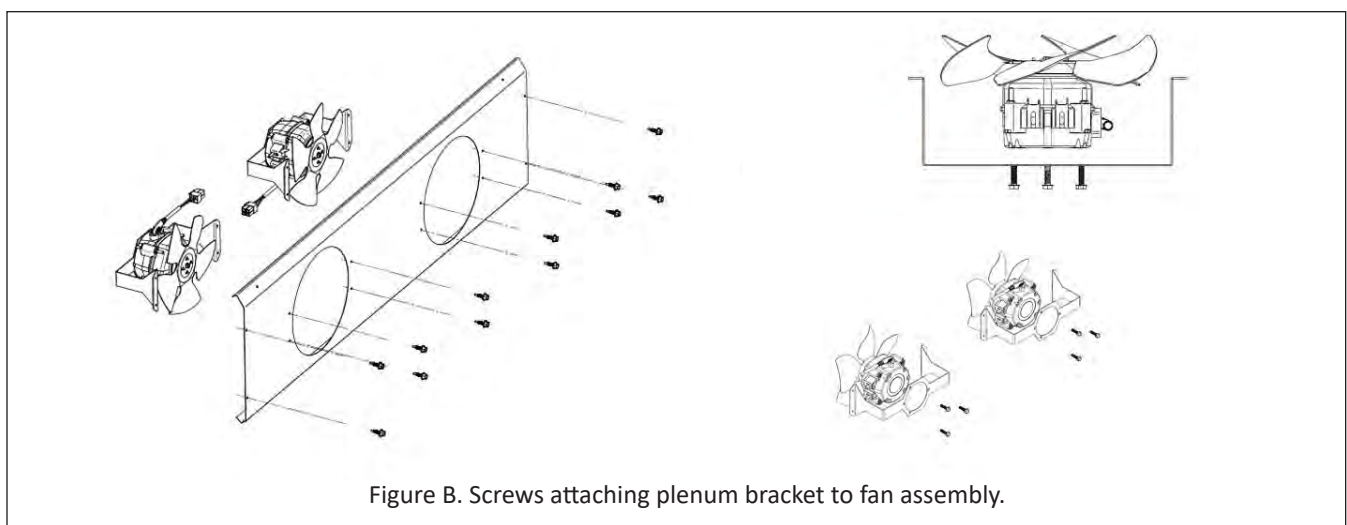
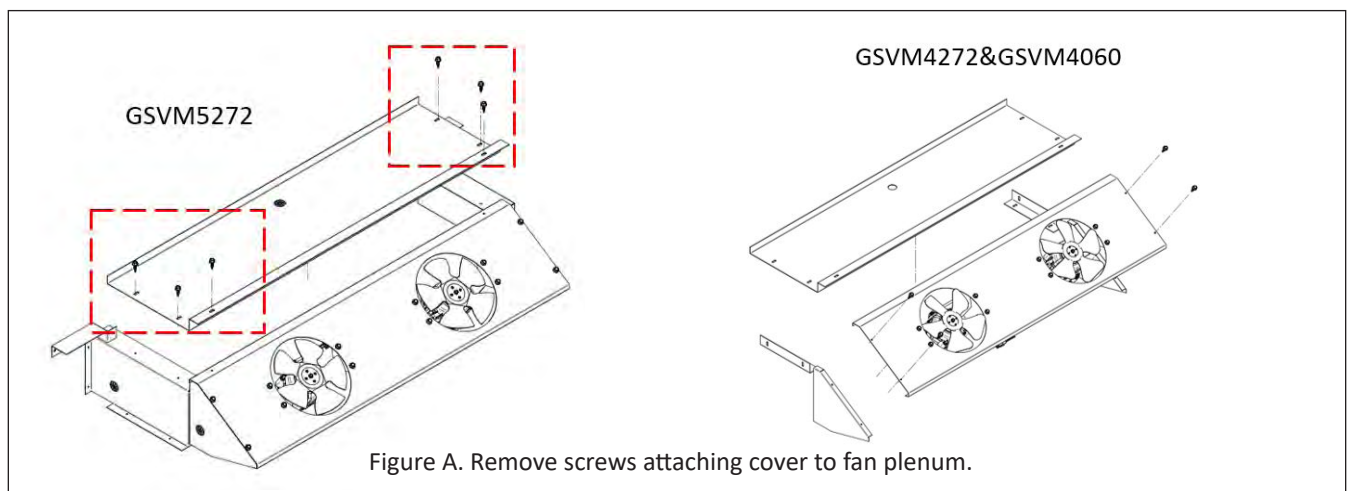

Figure C. Heater assembly

REPLACING FOOD COMPARTMENT FAN MOTORS AND BLADES

For access to these fans:

1. Remove product and place in a refrigerated area. Turn off power to the merchandiser.
2. Make sure there is no voltage in the refrigerator.
3. Remove step shelf in order to access the evaporator.
4. Disconnect evaporator fan motor harness for each motor.
5. Remove screws (3 on each side, 6 total) to remove evaporator cover Fig A
6. Once evaporator cover is removed, remove plenum / fan assembly.
7. Remove evap. fan motor screws (4 x motor) to get motor / blade assy. (Fig B). In total we have 8 screws to releases 2 motors.
8. Change the failed part.
9. If the only damaged part is the motor, remove blade.
10. Reverse the process and make sure everything is in place.



LED FIXTURE REPLACEMENT

Shelf LED fixtures are held in place by magnets. Pull the fixture down firmly to release disconnect cord from receptacle on the rear wall.

 **WARNING**

— LOCK OUT / TAG OUT —

To avoid serious injury or death from electrical shock, always disconnect the electrical power at the main disconnect when servicing or replacing any electrical component. This includes, but is not limited to, such items as doors, lights, fans, heaters, and thermostats.

 **WARNING**

Product will be degraded and may spoil if allowed to sit in a non-refrigerated area.

TROUBLESHOOTING GUIDE

PROBLEM	PROBABLE CAUSE	SOLUTION
Compressor will not start. (no noise)	<ol style="list-style-type: none"> 1. Power disconnected 2. Blown fuse or breaker 3. Defective or broken wiring 4. Defective overload 5. Defective temperature control 	<ol style="list-style-type: none"> 1. Check service cord or wiring connection 2. Replace fuse or reset breaker 3. Repair or replace 4. Replace 5. Replace
Compressor will not start; cuts out on overload.	<ol style="list-style-type: none"> 1. Low voltage 2. Defective compressor 3. Defective relay 4. Restriction (pinched cap tube) 5. Restriction (moisture) 6. Condenser blocked with dust and dirt 7. Defective condenser fan motor 	<ol style="list-style-type: none"> 1. Cabinet voltage must not be more than 5% below rating 2. Replace 3. Replace 4. Repair or replace 5. Leak check, replace drier evacuate and recharge 6. Clean condenser 7. Replace
Warm storage temperature	<ol style="list-style-type: none"> 1. Temperature control not set properly 2. Short or refrigerant 3. Cabinet location too warm 4. Refrigerant over-charge 5. Low voltage, compressor cycling on overload 	<ol style="list-style-type: none"> 1. Modify controller set point to a colder value. 2. Leak check, replace drier evacuate and recharge 3. Move to cooler location or correct excessive heat source 4. Purge system, evacuate and recharge 5. Compressor voltage must not be more than 5% below rating.
Compressor runs continuously; product too warm.	<ol style="list-style-type: none"> 1. Short of refrigerant 2. Inefficient compressor 3. Coil iced up 	<ol style="list-style-type: none"> 1. Leak check, replace drier, evacuate and recharge 2. Replace 3. Force manual defrost
Compressor runs continuously; product too cold	<ol style="list-style-type: none"> 1. Defective control 2. Control sensing element not in positive contact 3. Short on refrigerant 	<ol style="list-style-type: none"> 1. Replace 2. Assure proper contact 3. Leak check, replace drier evacuate and recharge

TROUBLESHOOTING LIGHT GUIDE

PROBLEM	SOLUTION
Lights won't start	<ol style="list-style-type: none"> 1. Check light switch 2. Check continuity to power supply 3. Check voltage
Lights flicker	<ol style="list-style-type: none"> 1. Light bar replacement may be necessary 2. Check voltage

GSVM-A ACCESSORIES

The following is a description of the various accessories available for the GSVM-A.

Caster Kit — Consists of 5 in. braking casters, which screw in to the standard threaded holes in the four corners under the cage occupied by the standard leg levelers. The kit will add 5 ⁵/₈ in. of height to the case.

Leg Kit — The legs also go into the same holes as the standard levelers, which will have to be removed. The legs are adjustable and will add 5 ⁵/₁₆ in. to the height of the case. The skirt kit requires the use of these legs.

Four-sided Skirt Kit — This is a four-sided skirt that encloses the open area under the merchandiser when the leg kit is used. The skirt kit clamps to the legs.

Wrap-Around Bumper Kit — This bumper replaces the standard front bumper and wraps around both sides of the merchandiser at the standard height of 22 inches to the centerline of the 2 ¹/₄ in. wide bumper.

Colored Accent Panel — This panel can be (a.) the top front panel over the product, (b.) the panel behind the bumper, or (c.) the access panel below the bumper panel, or any combination of these.

Shelf end Trim Kit — Consists of four painted steel ends for the standard 13 in. and 15 in. shelves. This trim conceals and protects the exposed ends of the shelves. The trim kit attaches by two snap fasteners supplied with each trim piece for the GSVM-4060A model.

Shelf Upslope Tilt Adapter Kit — This kit consists of four zinc coated wire adapters to increase the two standard shelves, upslope from 1 1/2° to 6°.

Price Tag Molding Kit — This kit consists of aluminum price tag molding for the standard shelves. Price tag moulding will hold both 1 in. and 1.235 in. standard price tags. (Note that the standard shelves accept 1.235 in. tags.)

Wire Product Stop Kit — This kit consists of a 2 in. high chrome plated open wire stops for the standard shelf. This stop is mounted under tension and should not be confused with the wire front in the partition kit.

Wire Partition Kit — This is a free-standing wire system, which attaches to the standard shelves, and consists of a wire front, (different from the product stop) two wire sides and two partitions from the front to back, all chrome plated and 3 inches high.

Wire Cross Divider — This is a 3 inch high and 4 inch-long divider that could be ordered to be used with the wire partition kit above.

Wire Basket Kits — One kit is available to replace the top 13 in. shelf or shelves, another is available to replace the bottom 15 in. shelf. Each kit consists of a wire basket, two brackets, and two dividers, which could also be used as ends. These parts are zinc plated. The baskets have an 8 in. high back and a 4 in sloped front.

Wire Basket Dividers — These are additional dividers, which can be with the wire baskets kit to obtain additional partitioned areas in the baskets.

Additional Lighted Shelf — This consists of an additional 13 in. lighted shelf that can be positioned between the two standard shelves. It is the same construction as the top standard 13 in. shelf.



HUSSMANN[®]

**To obtain warranty information
or other support, contact your
Hussmann representative.
Please include the model and
serial number of the product.**

Hussmann Corporation, Corporate Headquarters: Bridgeton, Missouri, U.S.A. 63044-2483