

HUSSMANN®

Insight®

Single & Multideck

Medium Temperature

Includes Front Door & Rear Load Cases

EVOLVE
technologies
compatible



Installation, Operation & Service Manual



MEDIUM TEMPERATURE

June 2025
P/N 0535974_W
Spanish P/N 0535975_W
French P/N 3206126_W
MANUAL - IO Insight Medium Temperature

TABLE OF CONTENTS

BEFORE YOU BEGIN	IV
Read these instructions completely and carefully.	iv
Legal Disclaimer	iv
ANSI Z535.5 Definitions	iv
Proposition 65	iv
ETL Listing	v
Federal / State Regulation	v
Climate Class	v
Additional Important Symbols.....	v
Serial Plate Location.....	v
QR Code.....	v
User Safety and Product Information.....	vi
R-744 (CO2) Equipped Models ONLY	vii
All Refrigerant Types	vii
Leak Detection	x
Before Working with R-744 (CO2) Refrigerant	xi
Before Working with R-744 (CO2) Refrigerant (cont.).....	xii
INSTALLATION	1-1
Case Clearance	1-1
Location.....	1-1
Installation Tool List	1-1
Shipping Damage.....	1-2
Unloading	1-2
Exterior Loading	1-2
Unloading using a pallet jack	1-2
Optional Casters and Dollies	1-3
Merchandisers Shipped with End Installed.....	1-3
End Shipping Braces	1-4
Shipping Rider.....	1-4
Case Leveling.....	1-5
Case Lineup Leveling	1-5
Joining Open Case in a Lineup	1-6
Apply Gaskets - Multideck	1-7
Case Joining - Multideck & Rearload	1-8
Apply Gaskets - Convertible.....	1-11
Case Joining - Convertible	1-12
Apply Gasket- Single Deck	1-16
Case Joining - Single Deck.....	1-17

Sealing Lineup Joints (all cases)	1-20
Rear Load and Door Case Installation	1-21
Apply Gaskets - Rear Load	1-24
Apply Gaskets - Doored Cases	1-25
Case Joining Doored and Rear Load.....	1-26
Doors - Installing, Removing, Adjusting	1-28
Adjusting EcoVision Doors	1-28
Adjusting Door Closing Speed.....	1-29
Replacing LED Mullion Light Bars.....	1-29
Installing End Assemblies	1-30
Case End Installation	1-31
Case View End Installation	1-32
Convertible Case End Installation	1-33
Single Deck Case End Installation	1-34
Partition Hardware.....	1-35
Same Case Partitions	1-36
Different Case Partitions.....	1-38
Acrylic Partition Hardware.....	1-43
Acrylic Partitions - Multideck	1-44
Installing Bumpers.....	1-46
Installing Night Blinds	1-47
Loading Blind Spring	1-49
Troubleshooting Night Blinds.....	1-50

REFRIGERATION / ELECTRICAL	2-1
Refrigerant.....	2-1
Piping Installation Requirements	2-2
Refrigerant Piping	2-3
Back Wall Piping Penetrations	2-4
Narrow and Wedge Case Connection use Shroud.....	2-5
Insulation	2-5
Suction Line	2-5
Liquid Line	2-6
Refrigeration Thermostat.....	2-6
Defrost Sequences.....	2-6
Merchandiser Electrical Data	2-6
Electrical Connections	2-6
Field Wiring.....	2-6
Identification of Field Wiring	2-7
Sensor Location.....	2-7

TABLE OF CONTENTS CONTINUED

DRIP PIPING / FIT & FINISH / SPLASHGUARDS..... 3-1

Waste Outlet and Water Seal	3-1
Installing Drip Piping	3-2
Final Alignment / Fit & Finish	3-7
Installing End Splashguards.....	3-11
Installing Splashguard Brackets	3-13
Installing Splashguards	3-14
Installing Splashguard Brackets Ultra-Low Front Cases.....	3-15

STARTUP / OPERATION..... 4-1

Startup / Operation	4-1
Load Limits	4-1
Stocking	4-1
Shelf Maximum Weight Limits.....	4-2
Multideck Shelf Configuration.....	4-2
Installing CaseShieldPTM(s) (Optional)	4-3
LED Fixtures	4-4
Procedure for Installing Lighted Shelves.....	4-4
Installing FDA/NSF Required Thermometer	4-7

MAINTENANCE AND SERVICE 5-1

Safety Checks	5-1
Before Working with Refrigerant.....	5-2
Care and Cleaning	5-4
Identification of Case Parts	5-5
Exterior Surfaces	5-6
Interior Surfaces	5-6
Recommended Cleaning Instructions.....	5-7
Cleaning Honeycomb Assemblies	5-8
Cleaning Mirrors	5-8
Removing Interior Back Panels.....	5-9
Bottom Liner Repair	5-9
Cleaning Under Merchandisers.....	5-11
Cleaning Coils	5-11
Cleaning Stainless Steel Front Rails	5-11
Removing Scratches from Bumper	5-11

SERVICE 5-12

Troubleshooting.....	5-12
Troubleshooting Continued	5-13
Refrigerant Removal, Evacuation and Recovery	5-14
Recovery Procedure	5-14
Refrigerant Charging Procedure	5-15
Replacing Fan Motors	5-16
Replacing Door Handles	5-18
Replacing Aluminum Coil	5-21
Decommissioning Process	5-22

APPENDIX 6-1

Replacing Fan Motors	6-1
Fan Speed Selector	6-3
Installing Type II Fan Speed Selector Kit	6-4
Type II Fan Speed Selector Location.....	6-5

BEFORE YOU BEGIN

READ THESE INSTRUCTIONS COMPLETELY AND CAREFULLY.

LEGAL DISCLAIMER

Review all safety warnings on the case and in this manual before attempting start-up. Hussmann shall not be liable for any repair or replacement made without the written consent of Hussmann, or when the product is installed or operated in a manner contrary to the printed instructions covering installation and service which accompanied such product. Please note that failure to follow the instructions in this document may void your factory warranty.

ANSI Z535.5 DEFINITIONS

The definitions below are used to clarify the magnitude and urgency of harm and damage, considering problems arising from misuse. Relative to their potential danger, the definitions are divided into five parts according to ANSI Z535 Series.

 **DANGER**

DANGER indicates a hazardous situation which, if not avoided, will result in death or serious injury.

 **WARNING**

WARNING indicates a hazardous situation which, if not avoided, could result in death or serious injury.

 **CAUTION**

CAUTION indicates a hazardous situation which, if not avoided, could result in minor or moderate injury.

NOTICE

NOTICE is used to address practices not related to personal injury.

SAFETY INSTRUCTIONS

Safety instructions (or equivalent) signs indicate specific safety-related instructions or procedures.

PROPOSITION 65



This warning does not mean that Hussmann products will cause cancer or reproductive harm, or is in violation of any product-safety standards or requirements. As clarified by the California State Government, Proposition 65 can be considered more of a 'right to know' law than a pure product safety law. When used as designed, Hussmann believes that our products are not harmful. We provide the Proposition 65 warning to stay in compliance with California State law.

It is your responsibility to provide accurate Proposition 65 warning labels to your customers when necessary. For more information on Proposition 65, please visit the California State Government Website.

ETL LISTING

These merchandisers are manufactured to meet ANSI / UL 60335-2-89 and CSA C22.2 standard requirements for safety.

Proper installation is required to maintain this listing. This appliance is to be installed in accordance with the Safety Standard for Refrigeration Systems, ANSI/ASHRAE 15.

FEDERAL / STATE REGULATION

These merchandisers, at the time they are manufactured, meet all federal and state/provincial regulations. Proper installation is required to ensure these standards are maintained. Near the serial plate, each case carries a label identifying the environment (temperature and relative humidity) in which the case was designed to be used.

CLIMATE CLASS

The test room climate class for this appliance is Climate Class 8. Climate Class 8 means the unit has been tested for maximum ambient of 75° F (23.9° C) dry bulb and 55% relative humidity for Type I conditions or 80° F (26.7° C) dry bulb and 55% relative humidity for Type II conditions.

ADDITIONAL IMPORTANT SYMBOLS

The symbols below indicate specific types of information on the unit.



High Pressure



Grounding Connection Location

SERIAL PLATE LOCATION

Serial plates are located on the left side, facing the case. The serial plate contains information about the specific model and its operating parameters.

NOTE:

A second serial plate for multi-deck cases is also located behind the return air grille in the same location as single-deck cases (shown below).

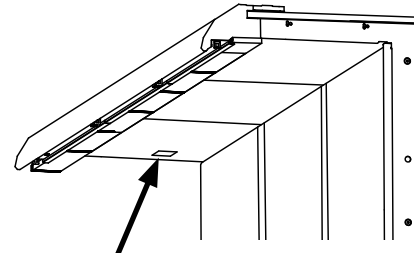

Serial Plate inside
Canopy (multideck)

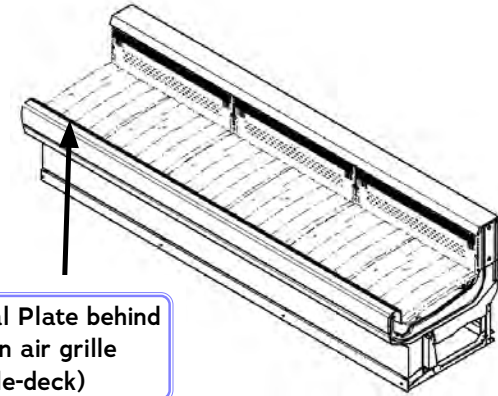

Serial Plate behind
return air grille
(single-deck)

QR CODE

Insight cases have a QR code located on the serial plate(s). Once you scan the QR code with a smart phone, all of the information about that case will be at your fingertips. Links to installation videos, data sheets with case specifications, the installation and operation manual, as well as a link to replacement parts from Hussmann's Performance Parts website.



USER SAFETY AND PRODUCT INFORMATION

General Safety Instructions

SAFETY INSTRUCTIONS

This manual was written in accordance with originally prescribed equipment that is subject to change. Hussmann reserves the right to change or revise specifications and product design in connection with any feature of our products.

Personal Protection Equipment (PPE) is required. Wear safety glasses, gloves, protective boots or shoes, long pants, and a long-sleeve shirt when working with this equipment and while handling glass.



The safety of our customers and employees is paramount. The precautions and procedures described in this manual are intended as general methods for safe use of this equipment. Please be sure to comply with the precautions described in this manual to protect you and others from possible harm. Always follow OSHA standards for safety.

Only qualified personnel should install and service this equipment. Personal Protection Equipment (PPE) is required. Wear safety glasses, gloves, protective boots or shoes, long pants, and a long-sleeve shirt when working with this equipment and while handling glass.

Observe all precautions on tags, stickers, labels and literature provided and referenced for this equipment. Use only Hussmann approved parts approved through the Hussmann Performance Parts Website. Verify that all repair parts are identical models to the ones they are replacing. Do not substitute parts such as motors, switches, relays, heaters, compressors, power supplies, or solenoids.

Read all safety information regarding the safe handling of refrigerant and refrigerant oil, including the Material Safety Data Sheet. MSDS sheets can be obtained from your refrigerant supplier. Service is to be performed by factory-authorized service personnel, so as to minimize the risk of possible injury due to incorrect parts or improper service. Contact your Hussmann representative to arrange servicing.

1. If the information in these instructions are not followed exactly, a fire or explosion may result, causing property damage, personal injury or death. Observe all precautions on tags, stickers, labels and literature attached to this equipment.
2. Installation and service must be performed by a qualified installer or service agency.

WARNING

R-744 (CO2) EQUIPPED MODELS ONLY

- **WARNING:** The refrigeration system is under high pressure. Do not tamper with it. Contact qualified service personal before disposal.
- If the refrigeration system is de-energized, venting of the R-744 through the pressure regulating relief valves on the refrigeration system can occur. In such cases, the system might need to be recharged with R-744, but in any case, the pressure regulating relief valve(s) shall not be defeated or capped. The relief setting shall not be altered.
- A sufficient number of pressure relief and pressure regulating relief valves might need to be provided based on the system capacity and located such that no stop valve is provided between the relief valves and the parts or section of the system being protected.
- A pressure relief device shall be installed in the high-pressure side of the refrigeration system between the motor-compressor and the gas cooler. There shall be no shut off devices or other components except piping between the motor-compressor and the pressure relief device that could introduce a pressure drop.
- The pressure relief device shall be mounted so that any refrigerant released from the system during its operation cannot cause harm to the user of the appliance. The aperture shall be located so that it is unlikely to be obstructed in normal use.
- The installed pressure relief device shall have no provisions for setting by the end user.
- The pressure setting of the installed pressure relief device shall be no higher than the design pressure of the high-pressure side.

ALL REFRIGERANT TYPES

- Be aware that refrigerants may not contain an odour.
- Excessive ambient conditions may cause condensation and sweating on doors. Facility operators are responsible for monitoring doors and floor conditions and ensuring the safety of all persons present. Installation and service must be performed by a qualified installer or service agency only as recommended by the manufacturer.
- If a leak is present or even suspected, do not allow untrained personnel to attempt to find the cause.
- A hand-held leak detector ("sniffer") will be used before any repair and/or maintenance.
- **WARNING:** Keep clear of obstruction, all ventilation openings in the appliance enclosure or in the structure for build-in.
- **WARNING:** Do not use mechanical devices or other means to accelerate the defrosting process, other than those recommended by the manufacturer.
- **WARNING:** Do not damage the refrigerating circuit.
- **WARNING:** Do not use electrical appliances inside the food/ice storage compartments unless they are the type recommended by the manufacturer.
- Do not use any means to clean, other than those recommended by the manufacturer.
- Do not use means to accelerate the defrosting process or to clean, other than those recommended by the manufacturer.
- The appliance shall be stored in a room without continuously operating ignition sources (for example: open flames, an operating gas appliance or an operating electric heater).
- Do not pierce or burn.

WARNING

- Do not store items or flammable materials atop the unit. Do not walk on case.
- Do not store explosive substances, such as aerosol cans with flammable propellant, in this appliance.
- This appliance is not intended for use by persons (including children) with reduced physical, sensory or mental capabilities, or lack of experience and knowledge, unless they have been given supervision or instruction concerning use of the appliance by a person responsible for their safety.
- Children should be supervised to ensure that they do not play with the appliance.
- Check that cabling will not be subject to wear, corrosion, excessive pressure, vibration, sharp edges, or any other adverse environmental effects. The check shall also take into account the effects of aging or continual vibration from sources such as compressors or fans.
- Any insulation shall be suitable for use with the material being insulated.
- Protection devices, piping, and fittings shall be protected as far as possible against adverse environmental effects, for example, the danger of water collecting and freezing in relief pipes or the accumulation of dirt and debris.
- Piping material, pipe routing, and installation shall include protection from physical damage in operation and service, and be in compliance with national and local codes and standards, such as ANSI/ASHRAE 15, IAPMO Uniform Mechanical Code, ICC International Mechanical Code, or CSA B52. All field joints shall be accessible for inspection prior to being covered or enclosed
- The installation of pipe-work shall be kept to a minimum.
- Mechanical connections made in accordance shall be accessible for maintenance purposes.
- Provision shall be made for expansion and contraction of long runs of piping.
- Piping in refrigeration systems shall be so designed and installed to minimize the likelihood of hydraulic shock damaging the system.
- Flexible pipe elements shall be protected against mechanical damage, excessive stress by torsion, or other forces, and that they should be checked for mechanical damage annually.
- Precautions shall be taken to avoid excessive vibration or pulsation.
- LOCK OUT / TAG OUT — To avoid serious injury or death from electrical shock, always disconnect the electrical power at the main disconnect when servicing or replacing any electrical component. This includes, but is not limited to, such items as doors, lights, fans, heaters, and thermostats.
- To reduce the risk of fire, electrical shock or injury when cleaning this merchandiser:
 - Unplug the merchandiser before cleaning.
 - Keep all liquids away from electrical and electronic components.
- Merchandiser must be grounded. All wiring must be in compliance with NEC and local codes.
- The appliance shall not be installed in public corridors or lobbies.
- Particular attention shall be paid to the following to ensure that by working on electrical components, the casing is not altered in such a way that the level of protection is affected. This shall include damage to cables, excessive number of connections, terminals not made to original specification, damage to seals, incorrect fitting of glands, etc.
- Ensure that the apparatus is mounted securely.

- Ensure that seals or sealing materials have not degraded to the point that they no longer serve the purpose of preventing the ingress of flammable atmospheres. Replacement parts shall be in accordance with the manufacturer's specifications.
- Where electrical components are being changed, they shall be fit for the purpose and to the correct specification. At all times, the manufacturer's maintenance and service guidelines shall be followed. If in doubt, consult the manufacturer's technical department for assistance.
- During repairs to sealed components, all electrical supplies shall be disconnected from the equipment being worked upon prior to any removal of sealed covers, etc. If it is absolutely necessary to have an electrical supply to equipment during servicing, then a permanently operating form of leak detection shall be located at the most critical point to warn of a potentially hazardous situation.
- Component parts shall be replaced with like components, and servicing shall be done by factory authorized service personnel only, so as to minimize the risk of possible ignition due to incorrect parts or improper service.
- Do not apply any permanent inductive or capacitance loads to the circuit without ensuring that this will not exceed the permissible voltage and current permitted for the equipment in use.
- After completion of field piping for split systems, the field pipework shall be pressure tested with an inert gas and then vacuum tested prior to refrigerant charging, according to the following requirements:
 1. The minimum test pressure for the low side of the system shall be the low side design pressure and the minimum test pressure for the high side of the system shall be the high side design pressure, unless the high side of the system cannot be isolated from the low side of the system in which case the entire system shall be pressure tested to the low side design pressure.
 2. The test pressure after removal of pressure source shall be maintained for at least 1 h with no decrease of pressure indicated by the test gauge, with test gauge resolution not exceeding 5% of the test pressure.
 3. During the evacuation test, after achieving a vacuum level specified in the manual or less, the refrigeration system shall be isolated from the vacuum pump and the pressure shall not rise above 1,500 microns within 10 min. The vacuum pressure level shall be specified in the manual, and shall be the lessor of 500 microns or the value required for compliance with national and local codes and standards, which may vary between residential, commercial, and industrial buildings.
- Solenoid valves shall be correctly positioned in the piping to avoid hydraulic shock.
- Solenoid valves shall not block in liquid refrigerant unless adequate relief is provided to the refrigerant system low pressure side.

FAILURE TO ABIDE BY THESE WARNINGS COULD RESULT IN AN EXPLOSION, DEATH, INJURY, AND PROPERTY DAMAGE. READ ALL WARNINGS PRIOR TO INSTALLING, PERFORMING MAINTENANCE, OR SERVICING THE EQUIPMENT IN ANY WAY.

⚠ CAUTION

- Do NOT use HOT water on cold glass surfaces. This can cause the glass to shatter and could result in personal injury. Allow glass fronts, to warm before applying hot water.
- Do NOT allow cleaning agent or cloth to contact food product.
- Product will be degraded and may spoil if allowed to sit in a non-refrigerated area.

NOTICE

- Merchandiser must operate for 24 hours before loading product!
- Regularly check merchandiser temperatures.
- Do not break the cold chain. Keep products in cooler or freezer before loading into merchandiser.
- Low temperature merchandisers are designed for loading ONLY frozen products.
- Medium Temperature merchandisers are designed for loading ONLY chilled products.

LEAK DETECTION

Under no circumstances shall potential sources of ignition be used in the searching for or detection of refrigerant leaks. A halide torch (or any other detector using a naked flame) shall not be used. The following leak detection methods are deemed acceptable for all refrigerant systems:

- Electronic leak detectors may be used to detect refrigerant leaks but, in the case of FLAMMABLE REFRIGERANTS, the sensitivity might not be adequate, or might need recalibration. (Detection equipment shall be calibrated in a refrigerant-free area.) Ensure that the detector is not a potential source of ignition and is suitable for the refrigerant used. Leak detection equipment shall be set at a percentage of the LFL of the refrigerant and shall be calibrated to the refrigerant employed, and the appropriate percentage of gas (25% maximum) is confirmed.
- Leak detection fluids are also suitable for use with most refrigerants but the use of detergents containing chlorine shall be avoided as the chlorine can react with the refrigerant and corrode the copper pipe-work.

Note: Examples of leak detection fluids are bubble method and fluorescent method agents.

If a leakage of refrigerant is found which requires brazing, all of the refrigerant shall be recovered from the system, or isolated (by means of shut off valves) in a part of the system remote from the leak. Removal of refrigerant shall be according to the Refrigerant Recovery section provided.

BEFORE WORKING WITH R-744 (CO₂) REFRIGERANT

Safety Checks

- **WARNING:** The refrigeration system is under high pressure. Do not tamper with it. Contact qualified service personal before disposal.
- R-744 (CO₂) systems have similar safety concerns with all conventional refrigerants, in that it displaces oxygen, is heavier than air and will concentrate closer to the floor if there is a system leak. R-744 should be monitored for leaks similar to other refrigerants.
- If the refrigeration system is de-energized, venting of the R-744 through the pressure regulating relief valves on the refrigeration system can occur. In such cases, the system might need to be recharged with R-744, but in any case, the pressure regulating relief valve(s) shall not be defeated or capped. The relief setting shall not be altered.
- A sufficient number of pressure relief and pressure regulating relief valves might need to be provided based on the system capacity and located such that no stop valve is provided between the relief valves and the parts or section of the system being protected.
- A pressure relief device shall be installed in the high-pressure side of the refrigeration system between the motor-compressor and the gas cooler. There shall be no shut off devices or other components except piping between the motor-compressor and the pressure relief device that could introduce a pressure drop.
- The pressure relief device shall be mounted so that any refrigerant released from the system during its operation cannot cause harm to the user of the appliance. The aperture shall be located so that it is unlikely to be obstructed in normal use.
- The installed pressure relief device shall have no provisions for setting by the end user.
- The pressure setting of the installed pressure relief device shall be no higher than the design pressure of the high-pressure side.
- Confirm operation of leak detectors (e.g., by exhaling near the sensor), audible / visible alarms, and machine room ventilation before operation.
- Ventilate adjacent enclosed areas to prevent the formation of dangerous concentrations of carbon dioxide.
- Avoid contact of the skin or eyes with solid carbon dioxide (dry ice) or objects cooled by solid carbon dioxide.
- Additional information on the safe use and handling of carbon dioxide can be found in Standards from the Compressed Gas Association Standard (www.cganet.com).
- The following checks shall be applied to installations:
 - a. The actual REFRIGERANT CHARGE is in accordance with the room size within which the refrigerant containing parts are installed.
 - b. The ventilation machinery and outlets are operating adequately and are not obstructed.
 - c. If an indirect refrigerating circuit is being used, the secondary circuit shall be checked for the presence of refrigerant.
 - d. Marking to the equipment continues to be visible and legible. Markings and signs that are illegible shall be corrected.
 - e. Refrigerating pipe or components are installed in a position where they are unlikely to be exposed to any substance which may corrode refrigerant containing components, unless the components are constructed of materials which are inherently resistant to being corroded or are suitably protected against being so corroded.

Asphyxiation

- R-744 is odorless, heavier than air, and is an asphyxiant gas. If sensor reading is maxed out or non-responsive assume an unsafe level of CO₂ and ventilate the room prior to entering.
- Practical limit of R-744 is 0.006 lb/ft³ (56,000 ppm).
- Personnel including rescue workers should not enter areas in which the carbon-dioxide content exceeds 3% (30,000 ppm) by measurement unless wearing an SCBA or supplied-air respirator.
- A leak of R-744 could result in a concentration exceeding the practical limit in an enclosed, occupied space such as a cold room. Precautions must be taken to prevent asphyxiation. These include the use of permanent leak detection, which activates an alarm in the event of a leak.
- The practical limit is defined in ASHRAE 34 but may vary depending on regional regulations.

CO₂ Quality

- CO₂ that is purchased for use in refrigeration systems should be of a purity level high enough to prevent accumulation of non-condensable gases and moisture. A build-up of these gases can block small orifices (such as expansion valves) or lead to high discharge pressure, reducing operation or causing the system to become inoperable.
- CO₂ is commercially available at several different purity levels. The common names and percent purity are listed below. Hussmann recommends using "Refrigeration Grade" (99.99% purity) CO₂.
- Mixing of higher purity grades of CO₂ is acceptable. Lower grades of CO₂ contain higher levels of contaminants and water and will decrease system performance. Higher levels of moisture may react with the CO₂ and form carbonic acid that can degrade component integrity. Hussmann recommends keeping enough refrigeration grade CO₂ on-site to charge the system.
- Medical grade CO₂ should not be used, due to the outlet pressure regulators typically present on tanks.
- Bone-Dry grade is the minimum acceptable purity to ensure proper operation of the equipment and is pure enough to technically prevent accumulation of non-condensable gases in the system.

R-744 at various concentrations in the air.

PPM of R-744 (CO ₂)	Effects
442	concentration in atmosphere
5,000	long-term exposure limit (8 hours)
15,000	short-term exposure limit (10 minutes)
30,000	discomfort, breathing difficulties, headache, dizziness, etc.
100,000	loss of consciousness, followed by death
300,000	quick and immediate death

R-744 (CO₂) purity:

R-744 (CO ₂) Grade	Purity
Industrial and Medical Grade	99.5%
Bone Dry (minimum acceptable)	99.8%
Anaerobic Grade	99.9%
Refrigeration Grade (recommended)	99.99%
Coleman/Instrument Grade	99.99%
Research Grade	99.999%
Ultra-Pure Grade	99.9999%

INSTALLATION

CASE CLEARANCE

A 4-inch (102 mm) space between the rear of the merchandiser and wall must be maintained for air circulation. However, in high ambient conditions, sweating may still occur. If this happens, install a method of forced ventilation such as a fan ventilation kit.

A 1.5 inch (38 mm) space between the rear of the merchandiser and wall must be maintained for air circulation. However, in high ambient conditions, sweating may still occur. If this happens install a method of forced ventilation such as a fan ventilation kit.

LOCATION

These merchandisers are designed for displaying products in air conditioned stores where temperature is maintained at or below the ANSI/NSF-7 specified level and relative humidity is maintained at or below 55%.

Placing refrigerated merchandisers in direct sunlight, near hot tables or near other heat sources could impair their efficiency.

Like other display cases, these are sensitive to air disturbances. Air currents passing around cases will seriously impair their operation. Do not allow air conditioning, electric fans, open doors or windows, etc. to create air currents around the cases.

Excessive ambient conditions may cause condensation and therefore sweating of doors. Facility operators should monitor doors and floor conditions to ensure safety of persons.

INSTALLATION TOOL LIST

Unloading From Trailer:

Lever Bar, J-bar or Lever Dolly
Moving Dolly
Pallet Jack

Setting Case Line-Up:

Level, 4 ft suggested
Ratchet
¼-inch Socket
⁵/₁₆-inch Socket
½-inch Socket
½-inch Open End Wrench
Cordless Impact Drill
Caulking Gun
10-inch Adjustable Crescent Wrench

WARNING

» Use caution when working around refrigeration lines or water lines. Damage to equipment and/or personal injury could occur.

SHIPPING DAMAGE

All equipment should be thoroughly examined for shipping damage before and during unloading. This equipment has been carefully inspected at our factory. Any claim for loss or damage must be made to the carrier. The carrier will provide any necessary inspection reports and/or claim forms.

Apparent Loss or Damage

If there is an obvious loss or damage, it must be noted on the freight bill or express receipt and signed by the carrier's agent; otherwise, carrier may refuse claim. The carrier will supply necessary forms.

Concealed Loss or Damage

When loss or damage is not apparent until after equipment is uncrated, a claim for concealed damage is made. Upon discovering damage, make request in writing to carrier for inspection within 15 days and retain all packing. The carrier will supply inspection report and required claim forms.

⚠️ WARNING

- » If the case is to be moved using a fork lift, position the forks of the lift directly under the arched pods or shipping rails. Use extreme caution when transporting cases. Personal injury or death could result if a case falls on personnel.

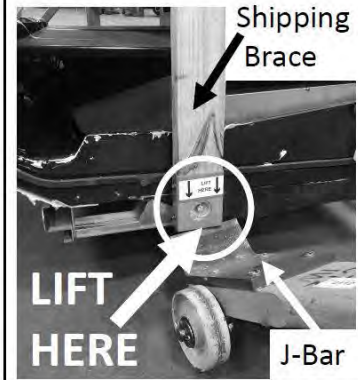

LIFT POINTS

Shipping Brace & Arched Pod

Installer lift at either of **THESE POINTS** with J-bar when moving case.

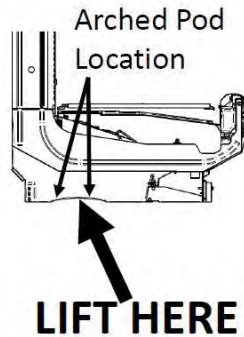

UNLOADING

Improper handling may cause damage to the merchandiser when unloading. Use the shipping brace and arched pod locations to lift when unloading cases.

1. Do not drag the merchandiser out of the trailer. Use a Johnson bar (mule).
2. Do not lift the case by the liner. Lift with the metal case base, arched plastic pods or the shipping brace.
3. Do not lift from the bottom edge of the end panel.

EXTERIOR LOADING

Do not walk on top of case(s) or damage to the case(s) and serious personal injury could occur. They are not structurally designed to support excessive external loading such as the weight of a person. Use caution when working around refrigeration lines or water lines, damage to equipment and personal injury could occur.

⚠️ WARNING

- » Do not walk on case. Do not store items or flammable materials atop the case.

UNLOADING USING A PALLET JACK

A pallet jack is also very helpful in moving a merchandiser to its permanent location. It can also be used to remove optional casters or to shim the case.



OPTIONAL CASTERS AND DOLLIES

Cases may be equipped with factory installed casters or dollies.

Instructions for removing the casters or dollies are included in a separate document, shipped with the case. Use caution when transporting cases from the truck to the store location.

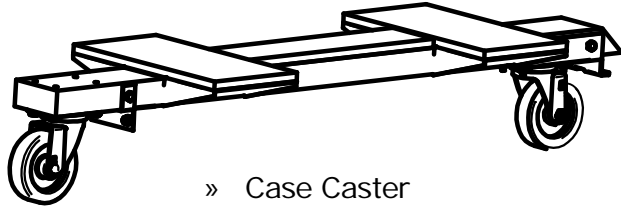

» Case Caster

⚠ WARNING

- » Use caution when moving cases with casters or dollies. Damage to equipment and personal injury could occur from improper handling.

MERCHANDISERS SHIPPED WITH END INSTALLED

If the merchandiser was shipped with the end installed, two long bolts were used to hold the shipping brace to the end. If the shipping bolts are reinserted after removing the brace, they will extend into the product area. Therefore, be sure to replace these bolts with the shorter bolts provided. NSF requires any bolt or screw in the product area be capped or cut off if it has more than three exposed threads.

Be careful not to damage the factory installed end while moving the merchandiser.



Be careful not to damage the factory installed end while moving the merchandiser.

END SHIPPING BRACES

Move the merchandiser as close as possible to its permanent location, then remove all packaging. Check for damage before discarding packaging. Remove all separately packed accessories such as kits and shelves.

Do not remove end braces until joining begins. Recycle wooden braces and hardware.

⚠ CAUTION

- » Do not remove shipping braces until the merchandisers are positioned for installation.

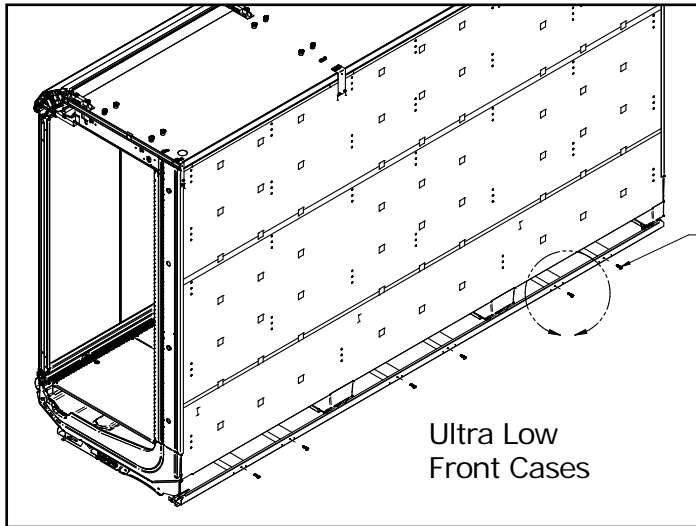

Remove 6 Screws and Wooden Supports Prior to Moving Case into Position (rear rail will remain attached to merchandiser)

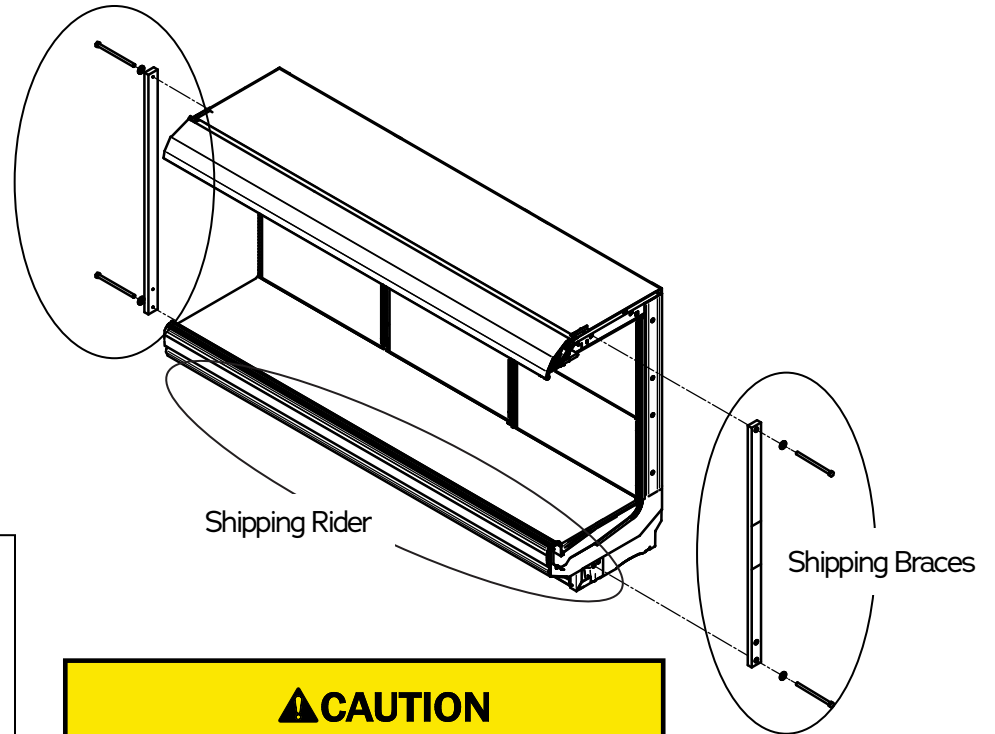

⚠ CAUTION

- » Tipping Hazard! Case tipping may occur if cases are not properly leveled and secured, or if cases are not properly loaded.

CASE LEVELING

Merchandisers must be installed level to ensure proper operation of the refrigeration system and to ensure proper drainage of defrost water. Pay close attention to case position during all steps of setting, joining and leveling.

NOTE:

Begin lineup leveling from the highest point of the store floor.

Preparation:

1. Using store blueprints, measure off and mark on floor the exact dimensions/locations of the merchandiser footprint. A 1 ½ inch space is required behind each merchandiser to prevent condensation.
2. Snap a chalk line for the front and rear positions of the base pods.
3. Mark the location of each joint from front to back lines.
4. Use supplied shims to level case. Shims are to be inserted under the black, plastic base pods.

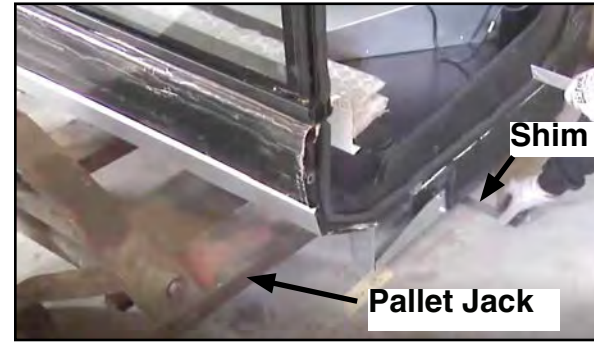
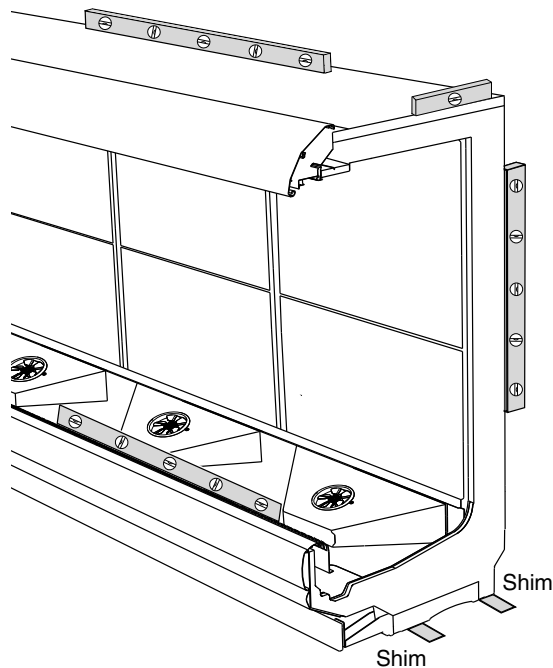

CASE LINEUP LEVELING

1. FLOORS ARE NOT LEVEL! The whole lineup must be leveled on the same plane, left to right and front to back. This means that the entire lineup must be brought up to the level of the highest case in the lineup.

Along the lines previously marked, find the highest point of the floor by:

- Walking the floor and noticing any dips or mounds;
 - Using a string level; and
 - Using a transit.
2. Position the first merchandiser at the highest point on the floor. Work outward from that point to create the merchandiser lineup.
 3. Use a 48 inch (1220 mm) or longer level for end-to-end leveling. The rear edge of the top foam panel of the merchandiser is a good location for the level at the rear of the case.
 4. For leveling the merchandiser front-to-rear, a 24 inch (610 mm) level should be placed on the lower flange of the merchandiser end frame. If the merchandiser has a factory installed end, the level should be placed on the canopy support brackets on top of the merchandiser. Suggested level locations are shown in the illustration.

JOINING OPEN CASE IN A LINEUP

JOINING AND SEALING HARDWARE	Multi Deck Qty/Each	Convertible Qty/Each	Single Deck Qty/Each	Door Multi Deck Qty/Each
SEALER SILICONE ADHESIVE	1	1	1	1
GASKET 1/2 X 1/2 X 180	2	1	1	2
SCREW-SHEET METAL #8 X 5/8 PHIL HX HD	N/A	1	N/A	N/A
SCREW-CAP 1/4 x 3/4 HEX	N/A	N/A	N/A	2
BOLT HEX CAP 5/16 x 3/4	1	1	1	1
BOLT 5/16 x 2 3/4 GRADE 5 ZINC PLATED TAP	2	N/A	N/A	2
BOLT- TAP, 5/16 x 4 1/2, STEEL, ZINC FINISH, GR5 (Qty Varies)	5	2	1	5
BOLT- TAP, 5/16 x 7, STEEL, ZINC FINISH, GR5	1	1	1	1
WASHER-FLAT 5/16" ZINC (Qty Varies)	13	5	3	13
LOCKWSHR 1/4 SPLT STL	N/A	N/A	N/A	2
LOCKWSHR 5/16 SPLT STL	1	1	1	1
NUT-HEX 1/4	N/A	N/A	N/A	2
NUT-HEX 5/16 STEEL ZINC FINISH GRADE 8 (Qty Varies)	9	4	3	9
NUT-HEX 3/8-24 SERRATED FLANGE	4	N/A	N/A	4
PIN-ALIGNMENT	1	1	1	N/A
CONE-CASE ALIGNMENT (Qty Varies)	4	2	2	4
PLATE-BOTT DOOR RAIL ALIGNMENT	N/A	N/A	N/A	1
BRACKET-CASE JOINING	4	N/A	N/A	4
BRACKET-FASCIA ALIGNMENT IC2 & IC3	N/A	1	N/A	N/A
COVER-HAND RAIL JOINT	1	1	1	N/A
TAPE-BUTYL 1/16 x 2" X 49"	1	1	1	1

IMPORTANT:

Do not pull cases together with bolts. Cases must be moved together as close as possible. Follow sequence balloons to tighten bolts.

- Apply gasket to only one side of case joint.
- Remove end shipping braces as described on Page 1-5.
- Cases must be leveled as described on Page 1-6.
- Removed any casters - if installed.
- Install case lineup from left to right.
- Remove shelves, display racks, pans & interior back panels at the joining area.
- Insert gasket into case channels the entire length with no gaps.
- Do not stretch gasket, especially around corners.
- Do not butt gaskets, always overlap them.
- Remove paper backing after gasket has been applied.
- Perimeter gasket is required by NSF.
- Apply a continuous bead of neutral curing silicone sealant.
- Joints must be air tight to prevent formation of ice of condensation.

NOTICE

It is the installing contractor's responsibility to consult local agencies for local code requirements.

NOTE:

See PAGE 1-22 at end of manual for joining rear load and door cases.

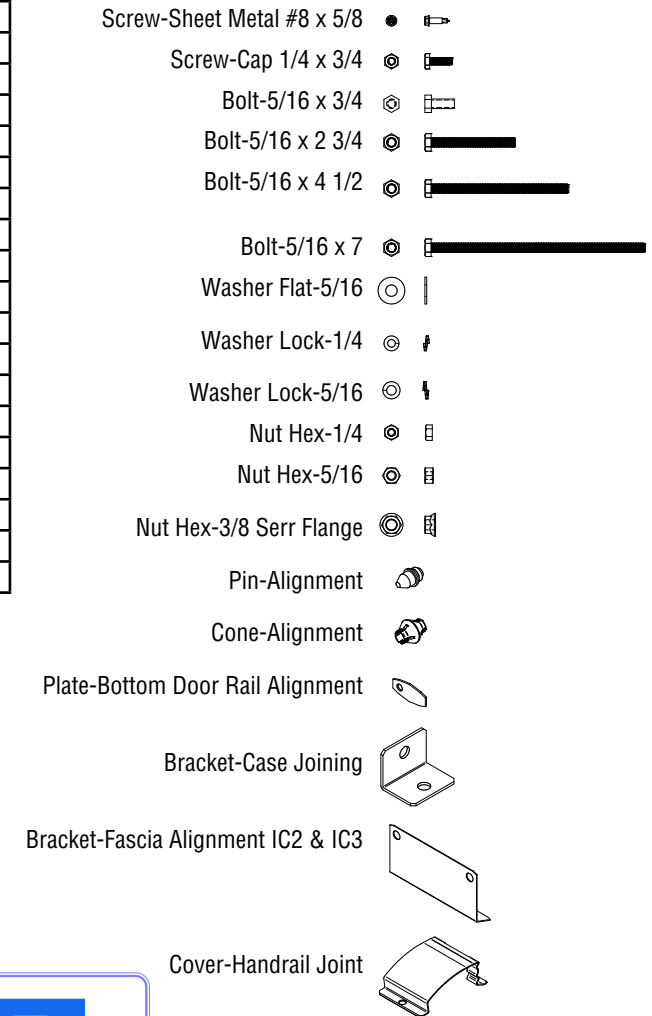

APPLY GASKETS - MULTIDECK

IP4 / IM5 / ID5 / ID6 / IC6 / IC4

Case bolting details begin on the next page.

LEGEND:

A = 1/2 x 1/2 INCH GASKET

B = NEUTRAL CURING SILICONE SEALANT

C = PIN-ALIGNMENT

D = COVER-HAND RAIL JOINT

IMPORTANT:

Do not pull cases together with bolts. Cases must be moved together as close as possible. Follow sequence balloons to tighten bolts.

- Apply gasket to only one side of case joint.
- Remove end shipping braces as described on Page 1-5.
- Cases must be leveled as described on Page 1-6.
- Removed any casters - if installed.
- Install case lineup from left to right.
- Remove shelves, display racks, pans & interior back panels at the joining area.
- Insert gasket into case channels the entire length with no gaps.
- Do not stretch gasket, especially around corners.
- Do not butt gaskets, always overlap them.
- Remove paper backing after gasket has been applied.
- Perimeter gasket is required by NSF.
- Apply a continuous bead of neutral curing silicone sealant.
- Joints must be air tight to prevent formation of ice or condensation.

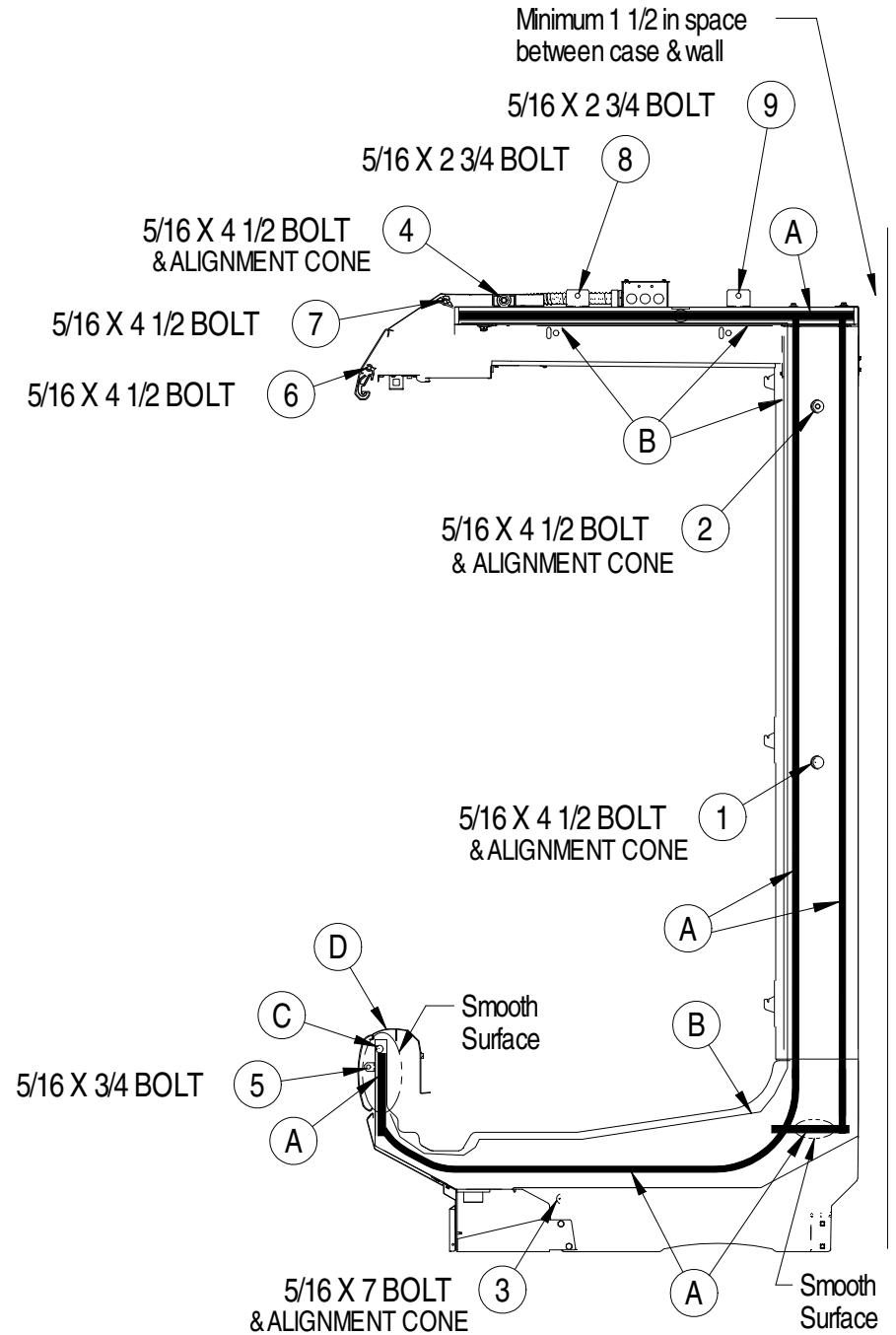

CASE JOINING - MULTIDECK & REARLOAD

IP4 / IM5 / ID5 / ID6 / IC6 / IC4 Refer to detail views.

LEGEND:

C = PIN-ALIGNMENT

Do not pull cases together with bolts. Cases must be moved together as close as possible. Follow sequence balloons to tighten bolts.

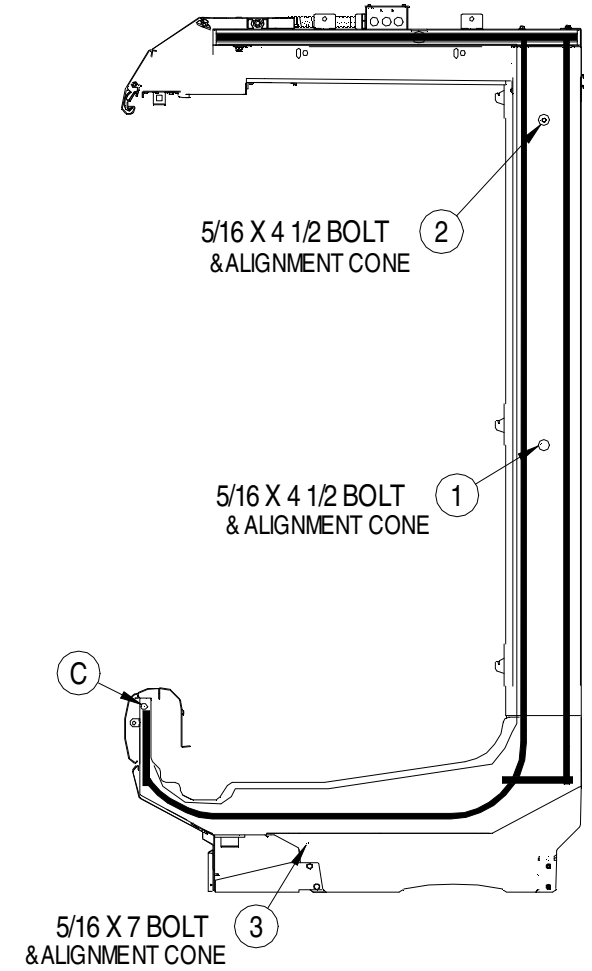
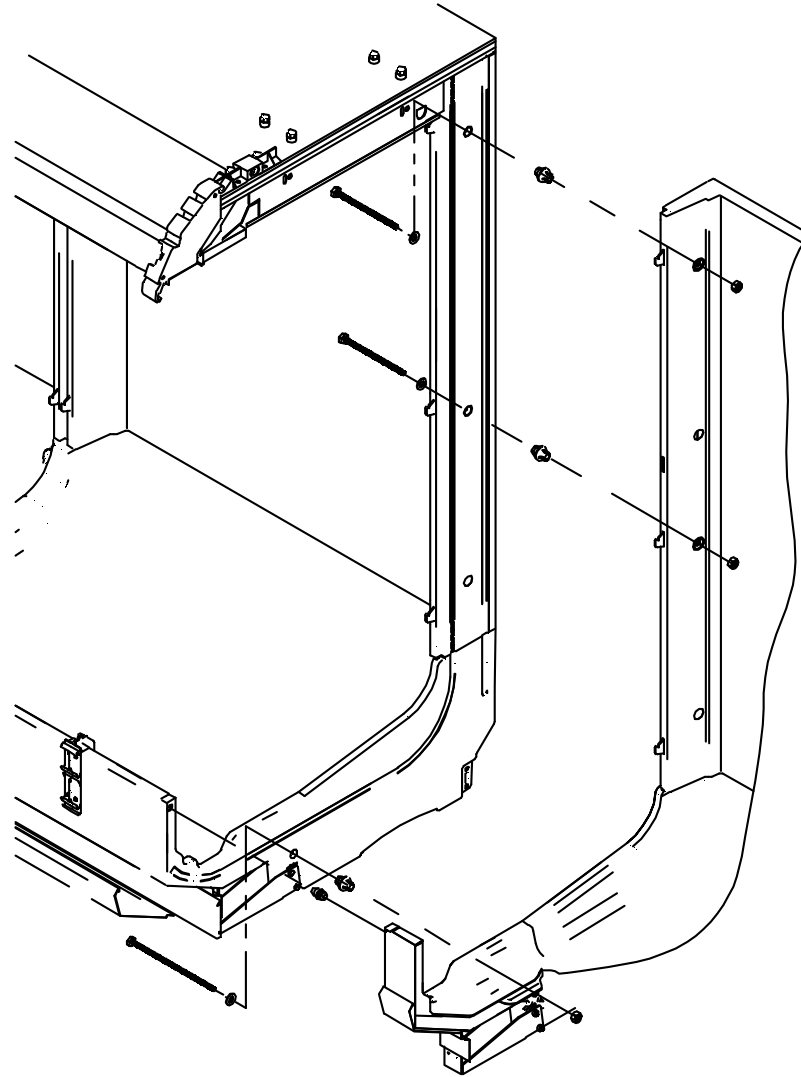

CASE JOINING - MULTIDECK & REAR LOAD

IP4 / IM5 / ID5 / ID6 / IC6 / IC4

Refer to detail views.

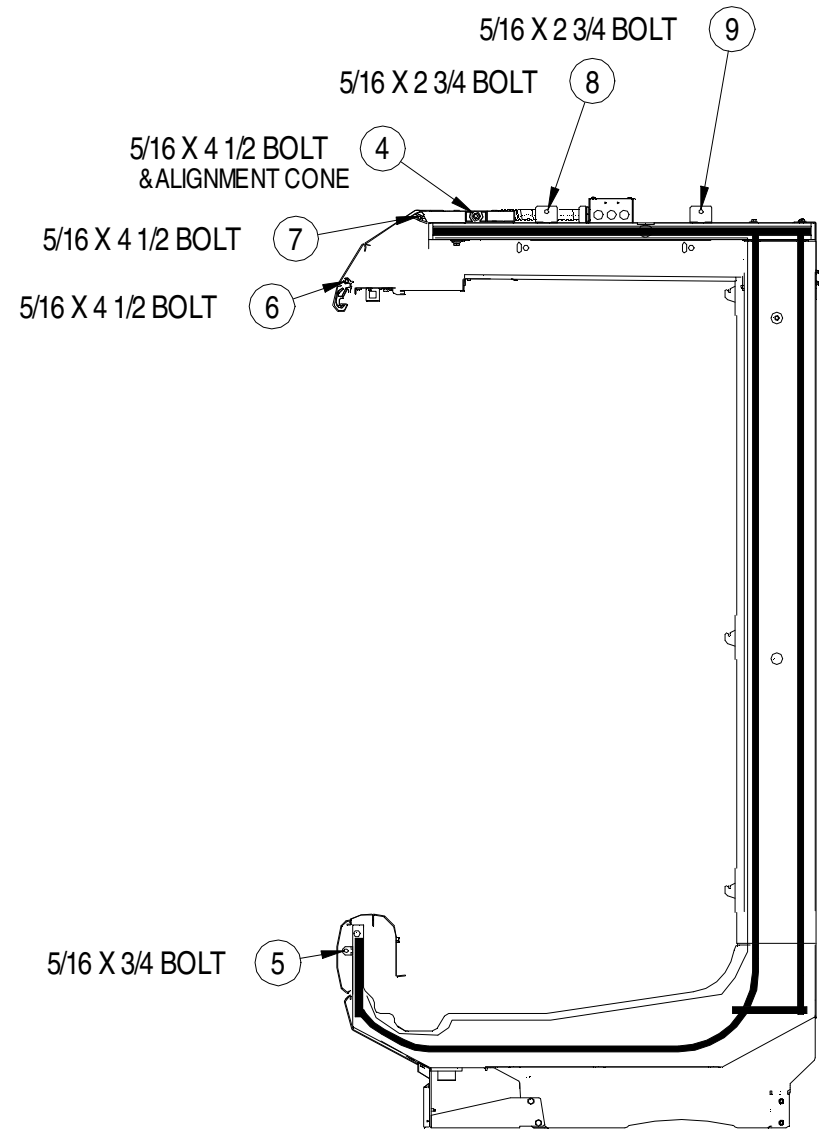
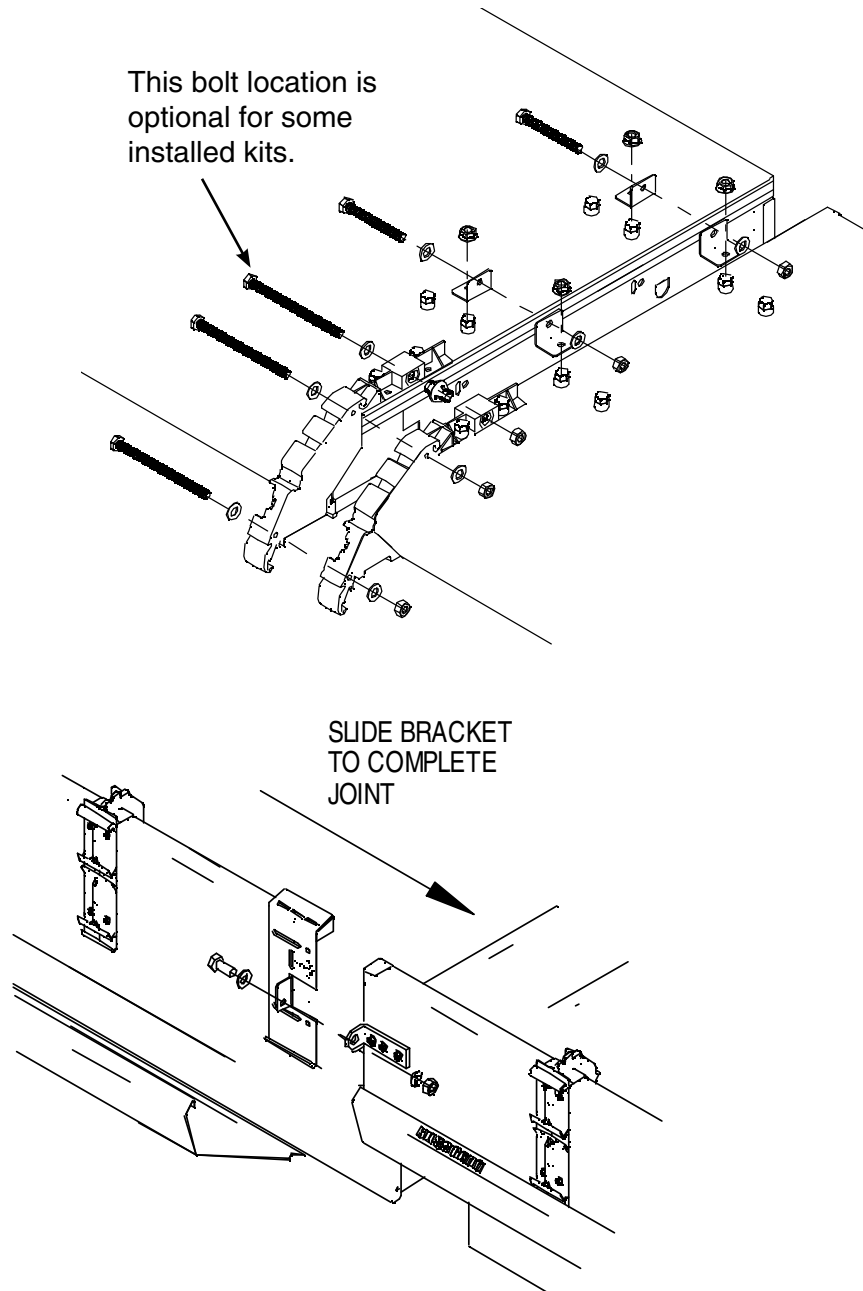

CASE JOINING MULTI-DECK & REAR LOAD

IP4 / IM5 / ID5 / ID6 / IC6 / IC4

Refer to detail views.

LEGEND:

D = COVER-HAND RAIL JOINT

Push Cover
in this direction
to snap fit

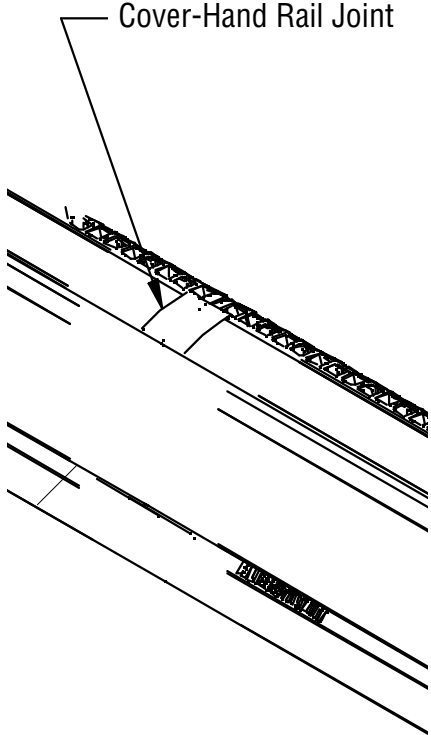
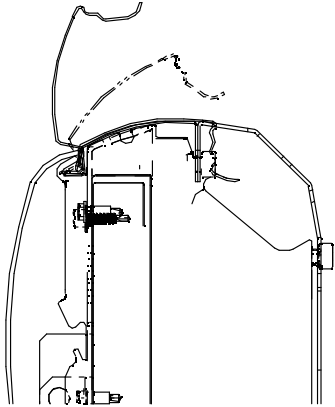

D

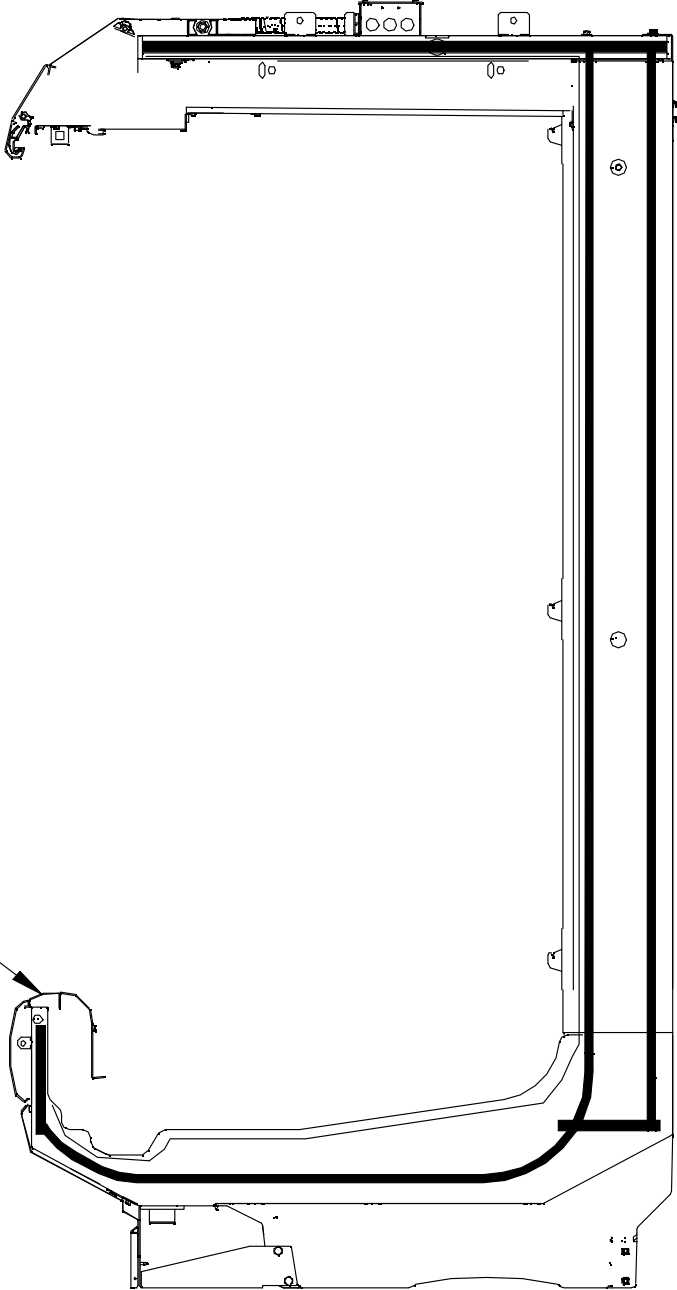

APPLY GASKETS - CONVERTIBLE

IC2 / IC2X / IC3

Case bolting details begin on the next page.

LEGEND:

A=1/2 X 1/2 INCH GASKET

B=NEUTRAL CURING SILICONE SEALANT

C=PIN-ALIGNMENT

D=COVER-HAND RAIL JOINT

E=BRACKET-FASCIA ALIGNMENT

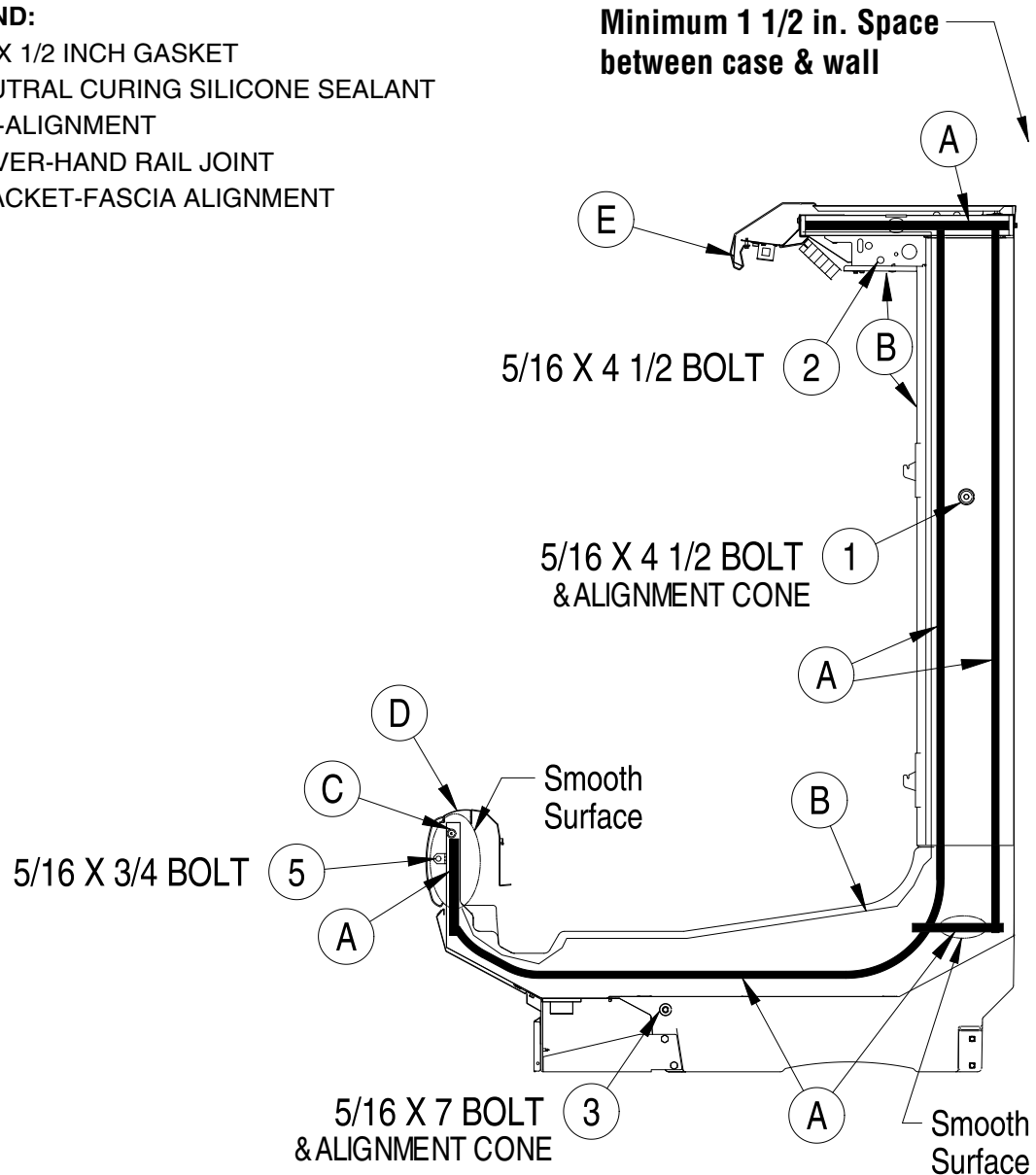

IMPORTANT:

Do not pull cases together with bolts. Cases must be moved together as close as possible. Follow sequence balloons to tighten bolts.

- Apply gasket to only one side of case joint.
- Remove end shipping braces as described on Page 1-5.
- Cases must be leveled as described on Page 1-6.
- Removed any casters - if installed.
- Install case lineup from left to right.
- Remove shelves, display racks, pans & interior back panels at the joining area.
- Insert gasket into case channels the entire length with no gaps.
- Do not stretch gasket, especially around corners.
- Do not butt gaskets, always overlap them.
- Remove paper backing after gasket has been applied.
- Perimeter gasket is required by NSF.
- Apply a continuous bead of neutral curing silicone sealant.
- Joints must be air tight to prevent formation of ice of condensation.

CASE JOINING - CONVERTIBLE

IC2 / IC2X / IC3 Refer to detail views.

LEGEND:

C=PIN-ALIGNMENT

E=BRACKET-FASCIA ALIGNMENT

Do not pull cases together with bolts. Cases must be moved together as close as possible. Follow sequence balloons to tighten bolts.

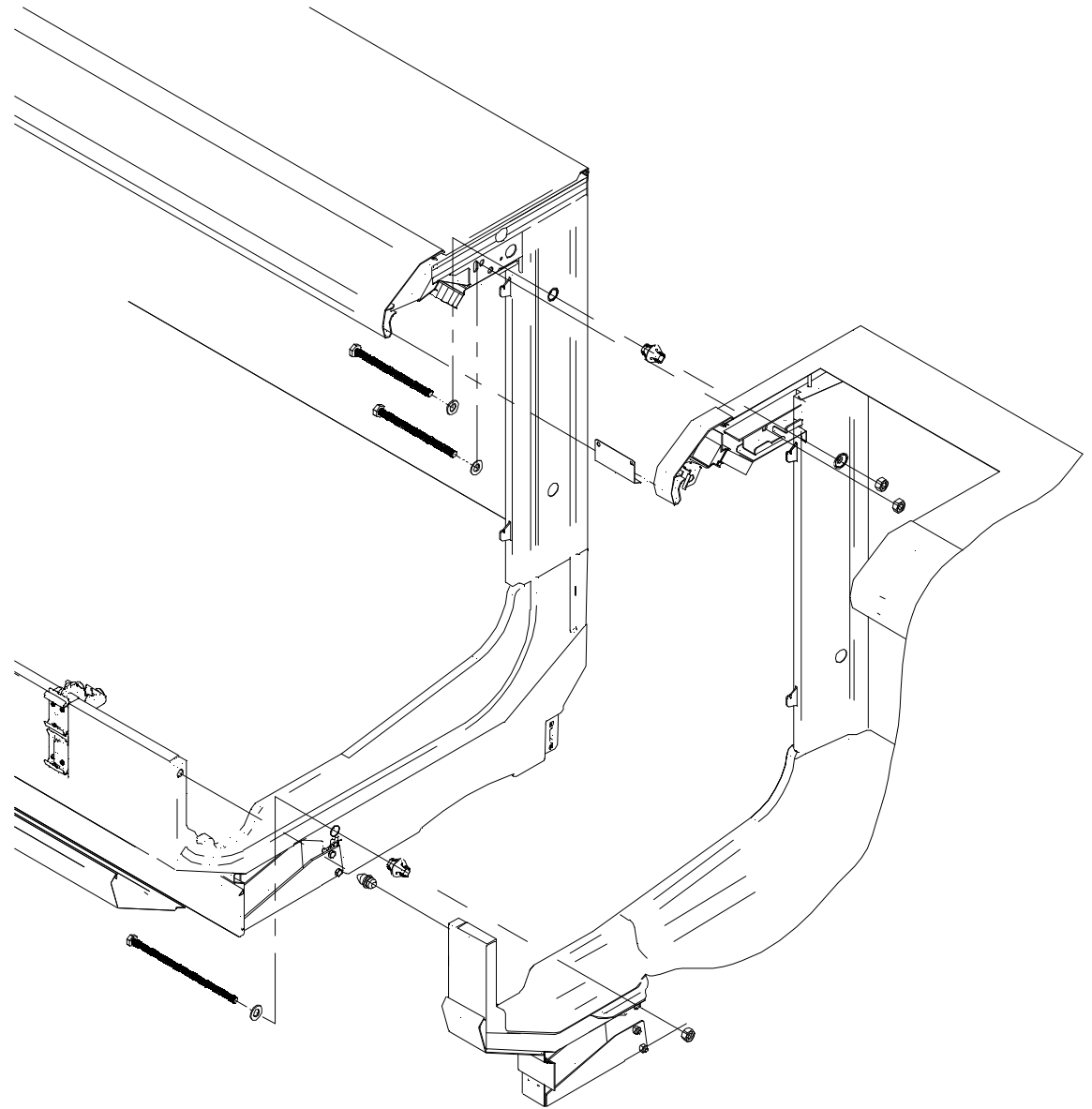
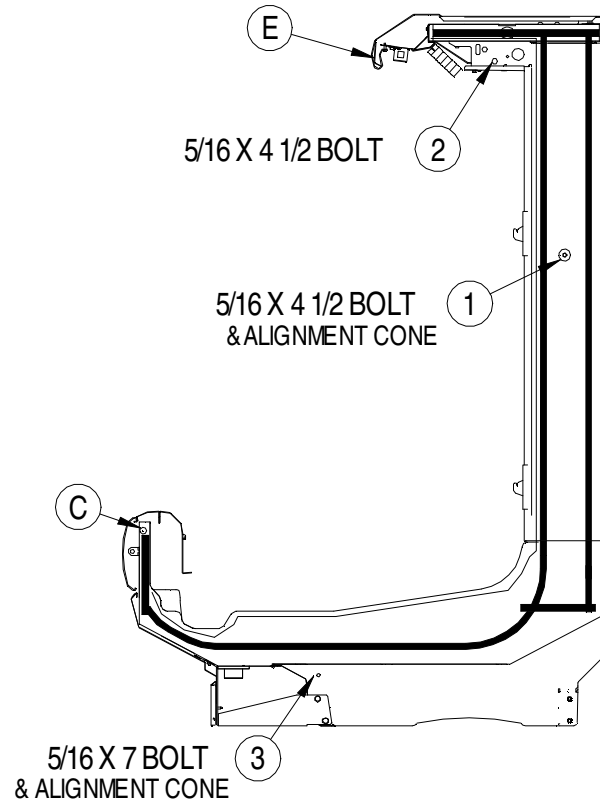

Case Joining - Convertible
IC2 / IC2X / IC3 Refer to detail views.

LEGEND:

E=BRACKET-FASCIA ALIGNMENT

(Can be modified by hand for better fit if necessary)

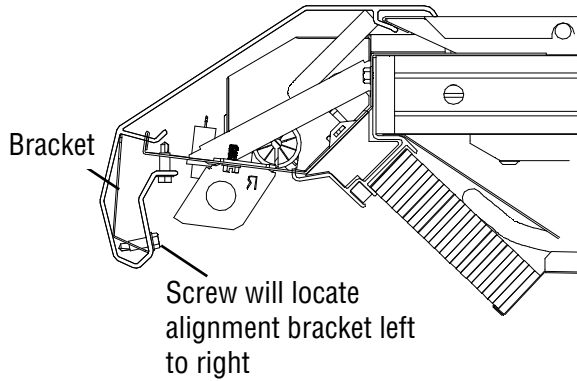

**Faceted Fascia
right side view**

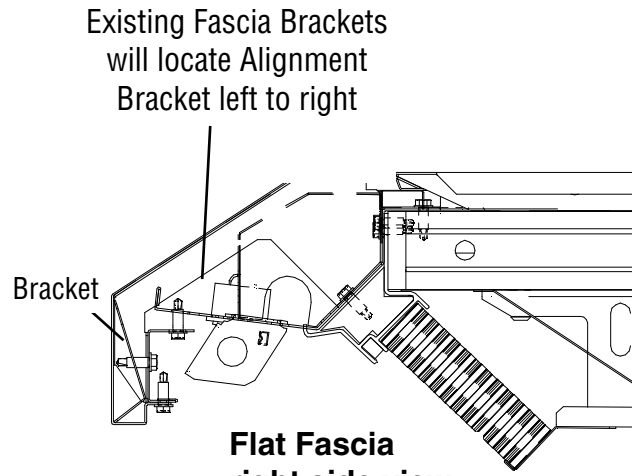

**Flat Fascia
right side view**

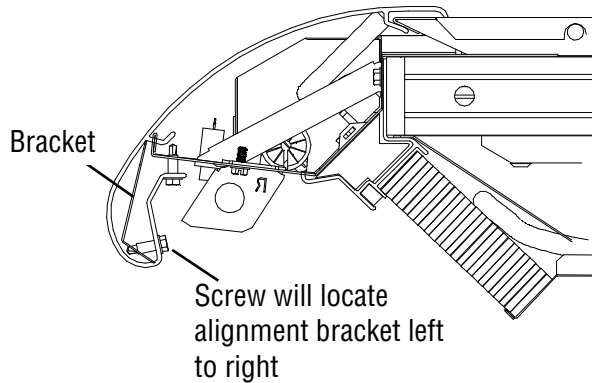

**Ellipse Fascia
right side view**

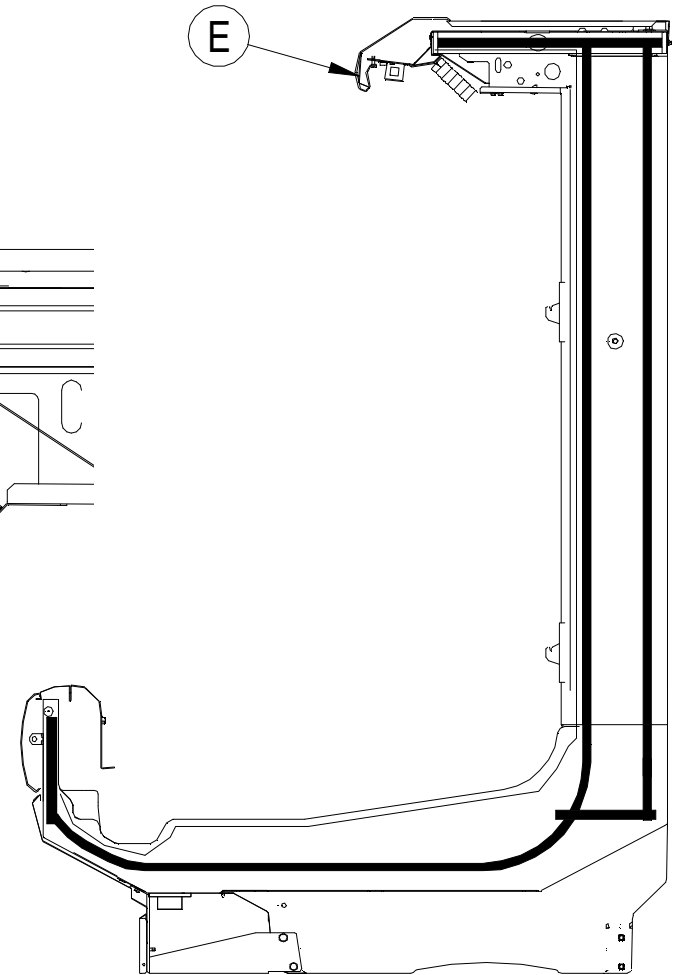

Case Joining - Convertible
IC2 / IC2X / IC3 Refer to detail views.

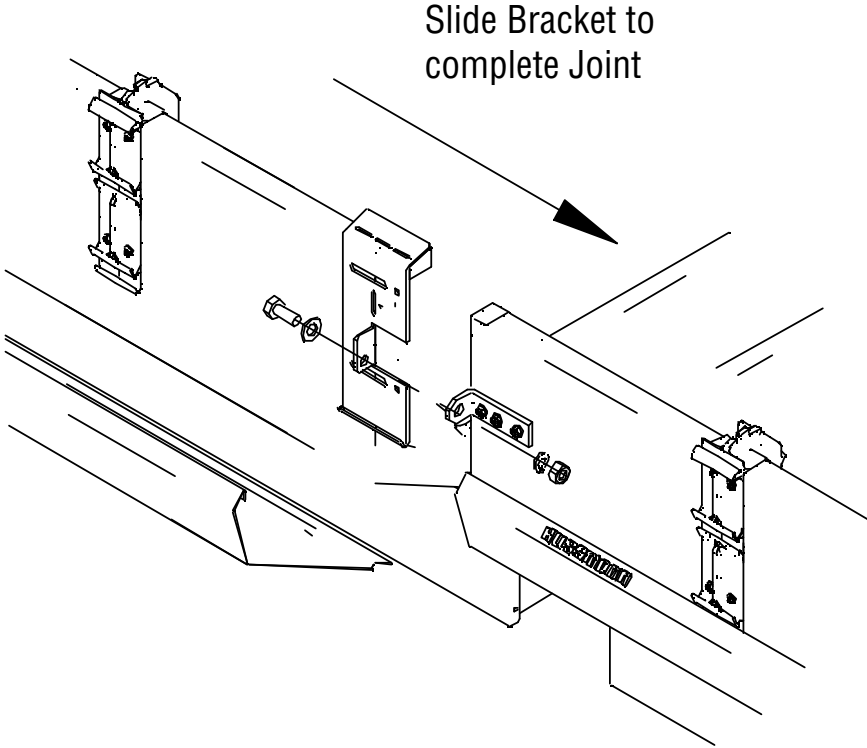

5/16 X 3/4 BOLT

5

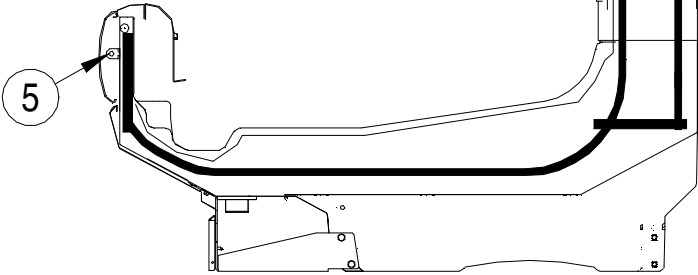

CASE JOINING (CONVERTIBLE)
IC2 / IC2X / IC3 Refer to detail views.

LEGEND:

D = COVER-HAND RAIL JOINT

Push Cover
in this direction
to snap fit

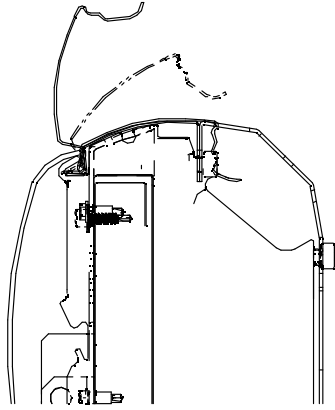

Cover-Hand
Rail Joint

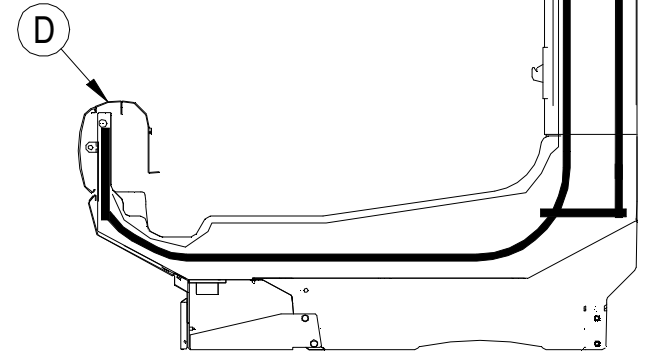
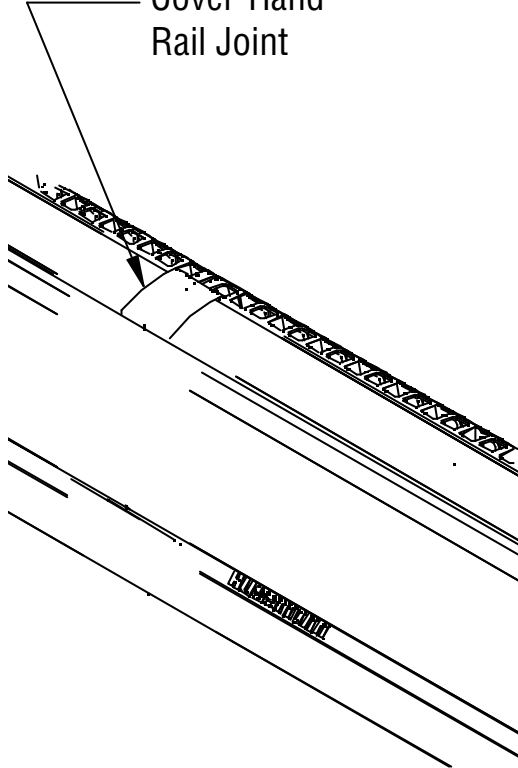

APPLY GASKET- SINGLE DECK

IM1 / IP1 Case bolting details begin on the next page.

LEGEND:

A = 1/2 x 1/2 INCH GASKET

B = NEUTRAL CURING SILICONE SEALANT

C = PIN-ALIGNMENT

D = COVER-HAND RAIL JOINT

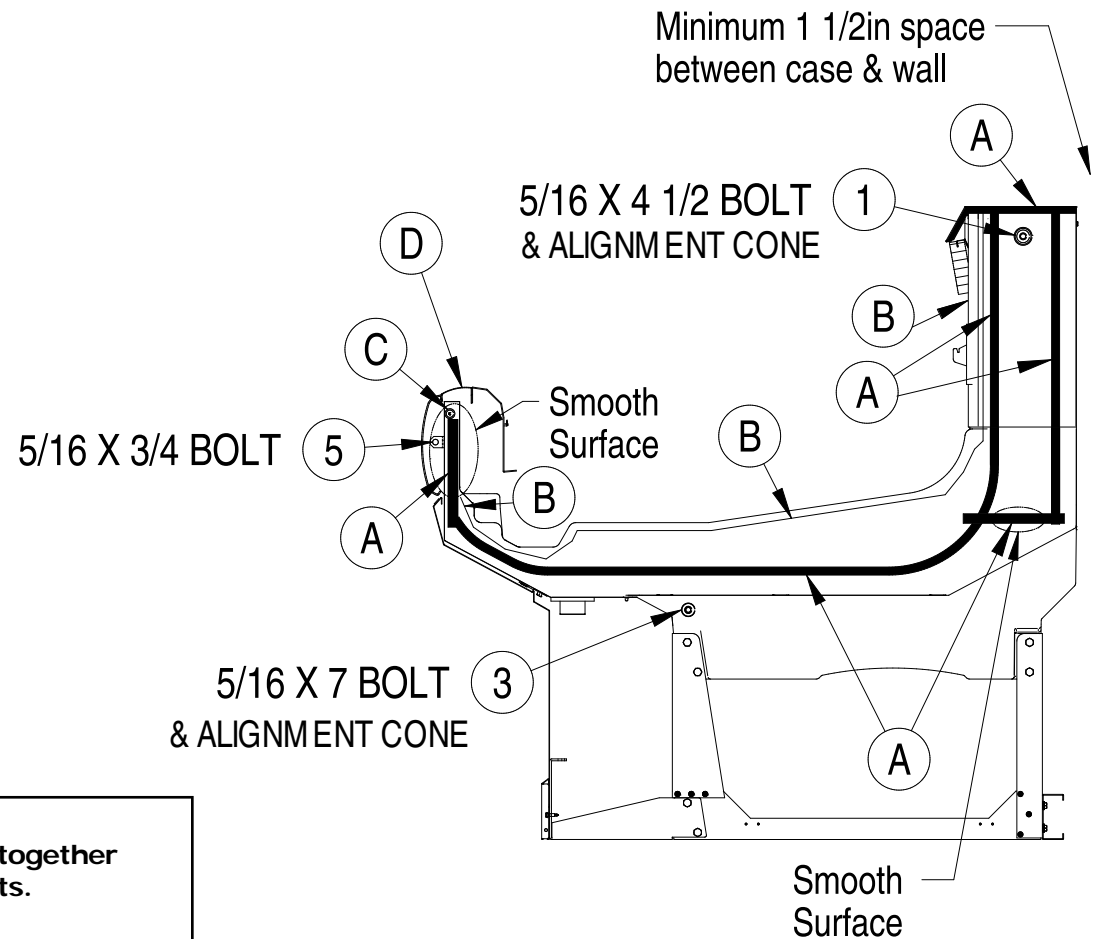

IMPORTANT:

Do not pull cases together with bolts. Cases must be moved together as close as possible. Follow sequence balloons to tighten bolts.

- Apply gasket to only one side of case joint.
- Remove end shipping braces as described on Page 1-5.
- Cases must be leveled as described on Page 1-6.
- Removed any casters - if installed.
- Install case lineup from left to right.
- Remove shelves, display racks, pans & interior back panels at the joining area.
- Insert gasket into case channels the entire length with no gaps.
- Do not stretch gasket, especially around corners.
- Do not butt gaskets, always overlap them.
- Remove paper backing after gasket has been applied.
- Perimeter gasket is required by NSF.
- Apply a continuous bead of neutral curing silicone sealant.
- Joints must be air tight to prevent formation of ice of condensation.

CASE JOINING - SINGLE DECK

IM1 / IP1 Refer to detail views.

LEGEND:

C = PIN-ALIGNMENT

Do not pull cases together with bolts. Cases must be moved together as close as possible. Follow sequence balloons to tighten bolts.

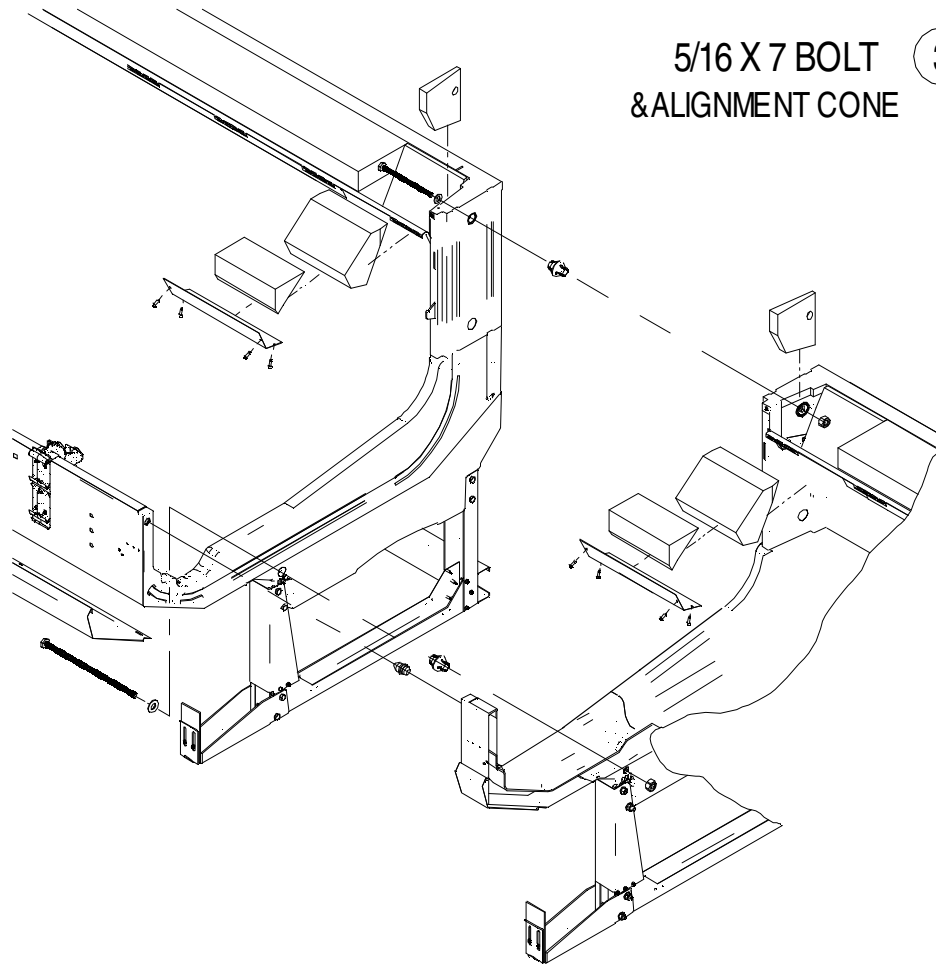

5/16 X 7 BOLT
& ALIGNMENT CONE

3

5/16 X 4 1/2 BOLT
& ALIGNMENT CONE

1

C

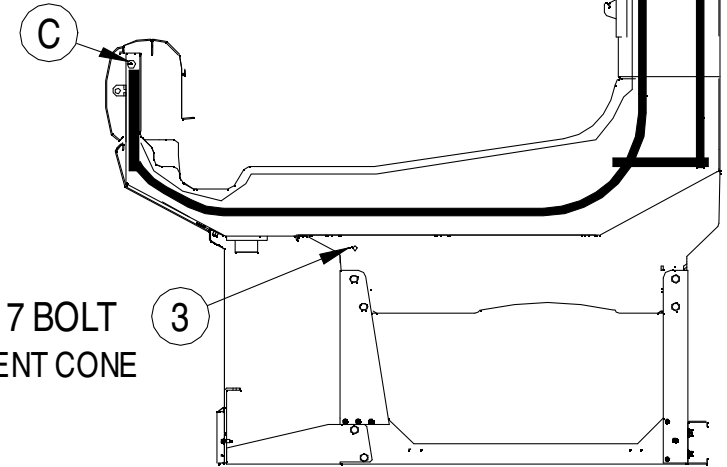

Case Joining - Single Deck
IM1 / IP1 Refer to detail views.

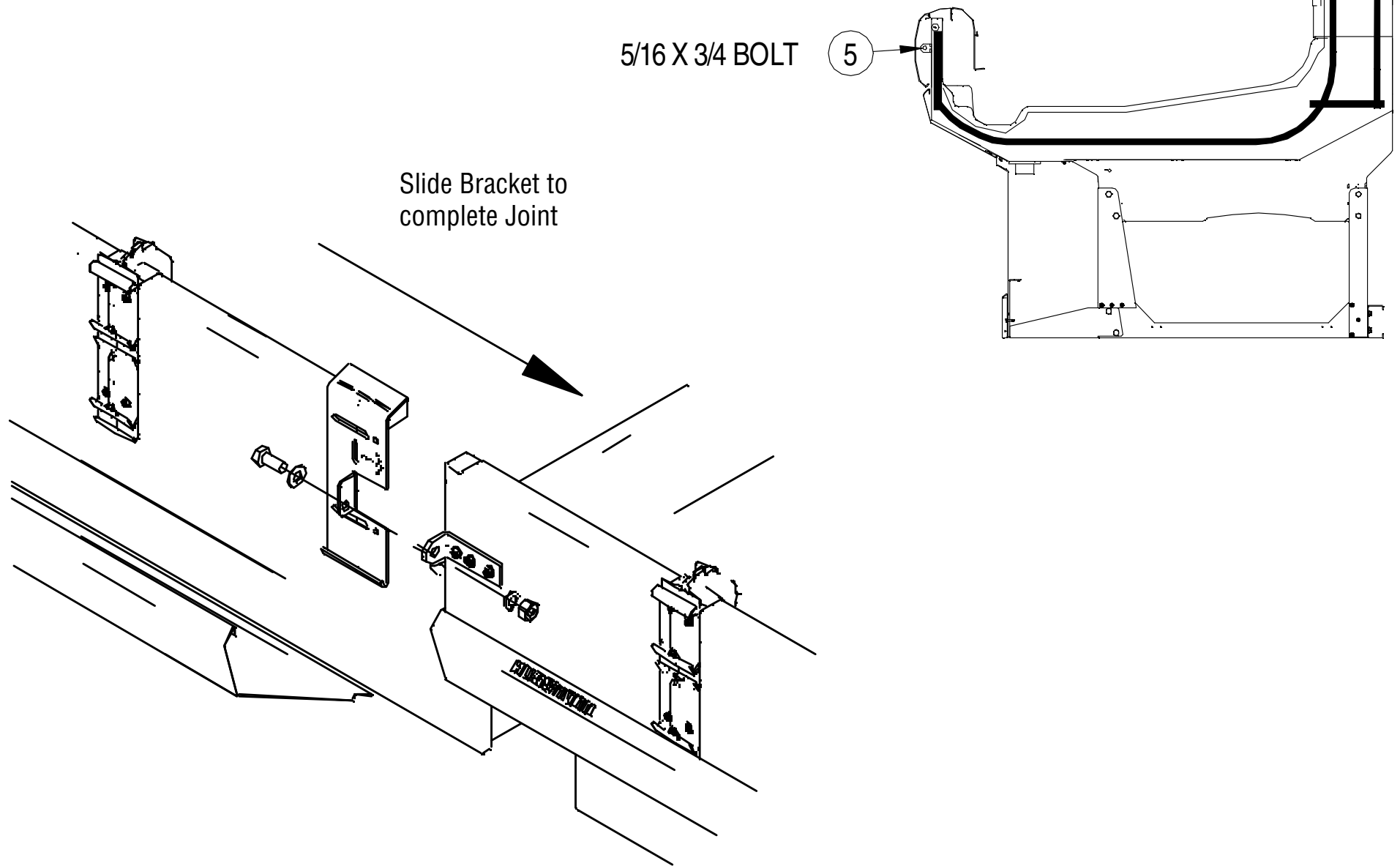

Case Joining - Single Deck
IM1 / IP1 Refer to detail views.

LEGEND:
D = COVER-HAND RAIL JOINT

Push Cover
in this direction
to snap fit

D

Cover-Hand
Rail Joint

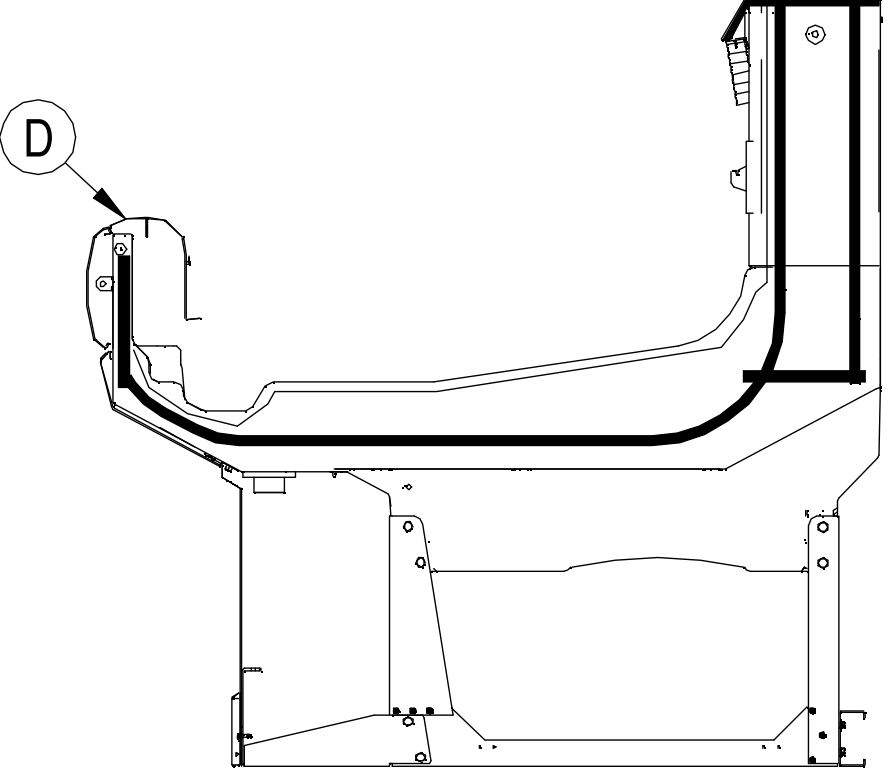
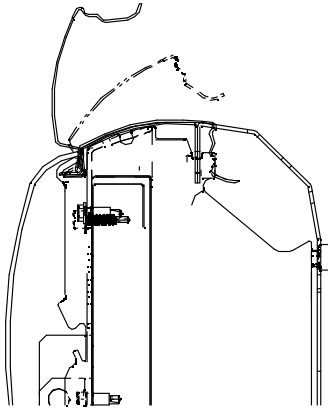
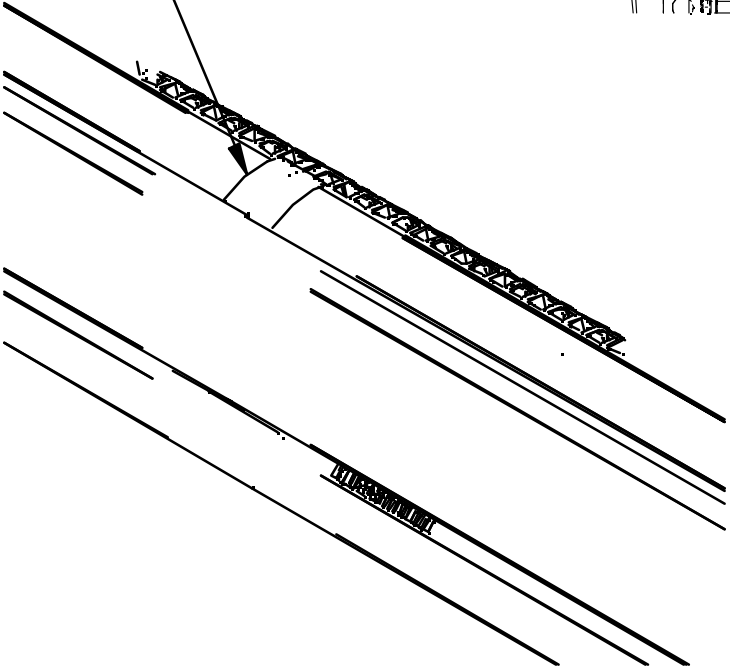

SEALING LINEUP JOINTS (ALL CASES)

The joint between the two joined case must be sealed for sanitation. Apply Butyl tape across the case joint. Apply a long, continuous bead of silicone to fill any gaps between the cases.

Be sure to start from the back and go all the way to the air return as shown in the illustration below.

⚠ WARNING

» Use caution when working around refrigeration lines or water lines, damage to equipment and personal injury could occur.

! **IMPORTANT** Fill any gaps between cases with silicone.

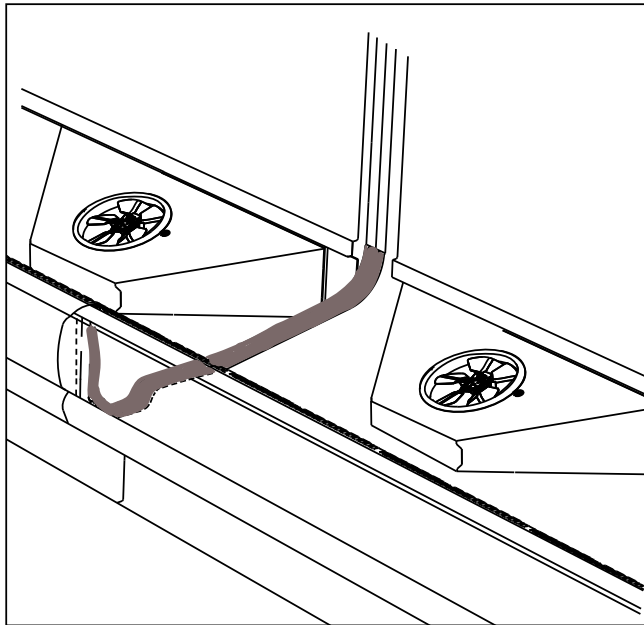

Apply Butyl Tape

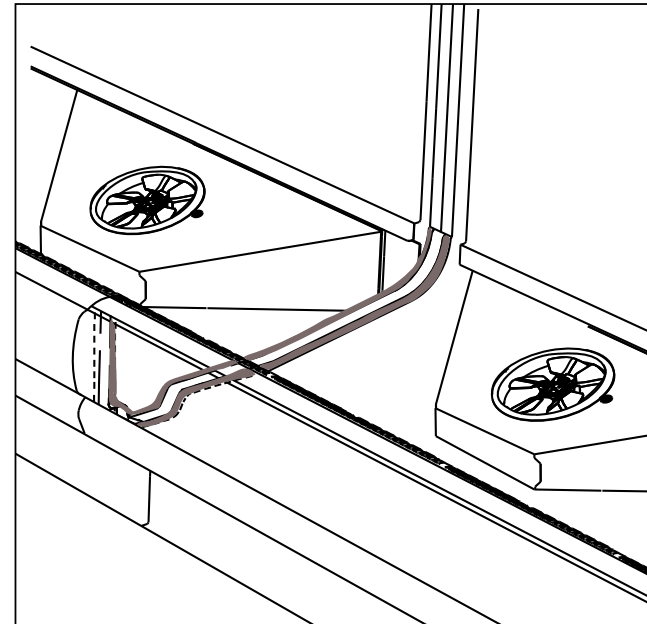

**Apply Neutral Curing
Silicone Sealant**

**Apply Neutral Curing Silicone Sealant
in any gaps between the Case Joints.**

REAR LOAD AND DOOR CASE INSTALLATION

Rear Load

Sealing case(s) in front of cooler opening:

Rear load cases are designed to be installed in the cooler opening. A 1½ in. gap around the outside of the cooler opening must be maintained. Use the dimensions below to build a sealed wall between the cooler opening and the rear of the case(s). Use silicone around the perimeter of the frame to seal the cases on the inside and outside of the cooler.

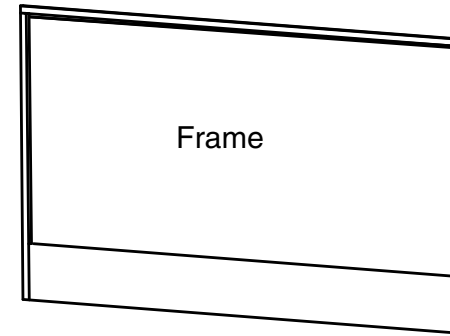

A frame must be built between the cooler opening and the rear loading area of the case(s). Seal the frame with silicone. The area around the rear access doors should be sealed to the cooler wall. The seal should be air and water tight.

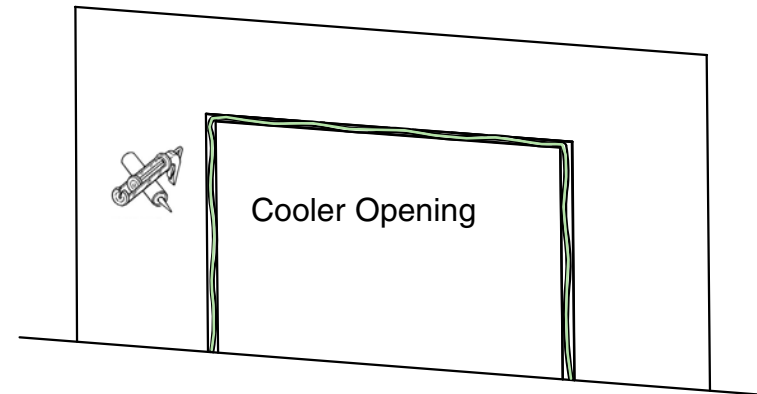

Rear Access Doors

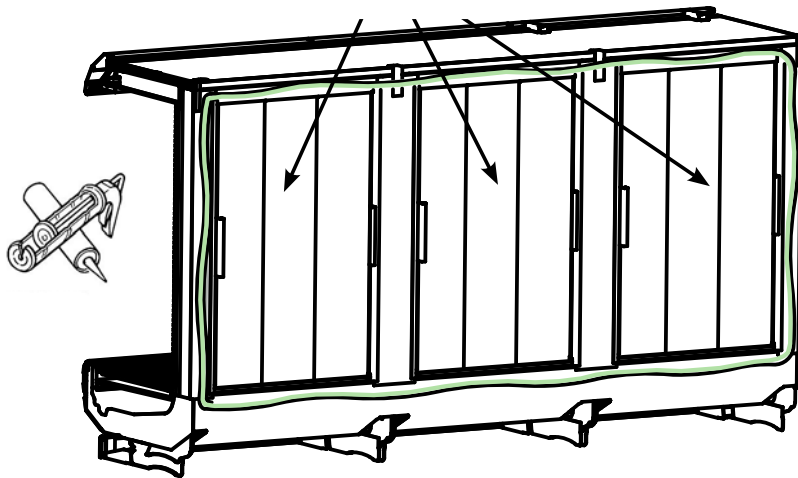

**REAR VIEW DIMENSIONS ID6SUR / ID5SLR
OF CASES WITH EXTERNAL SLIDING
REAR LOADING DOORS
(4 ft, 6 ft, 8 ft, 12 ft)**

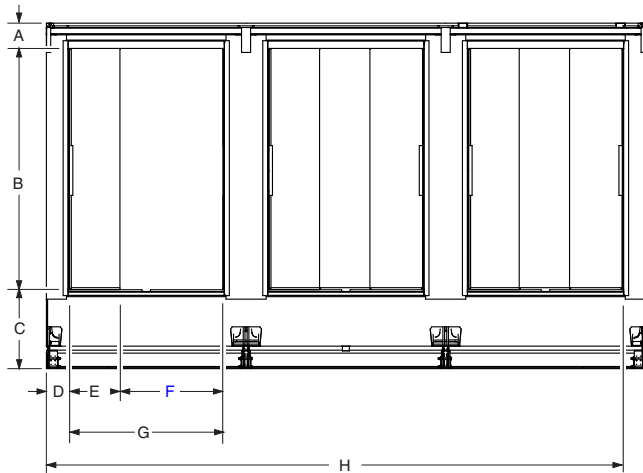

*Dimension E and F is with doors fully opened.

Rear Views

Double-walled telescoping doors slide both left and right

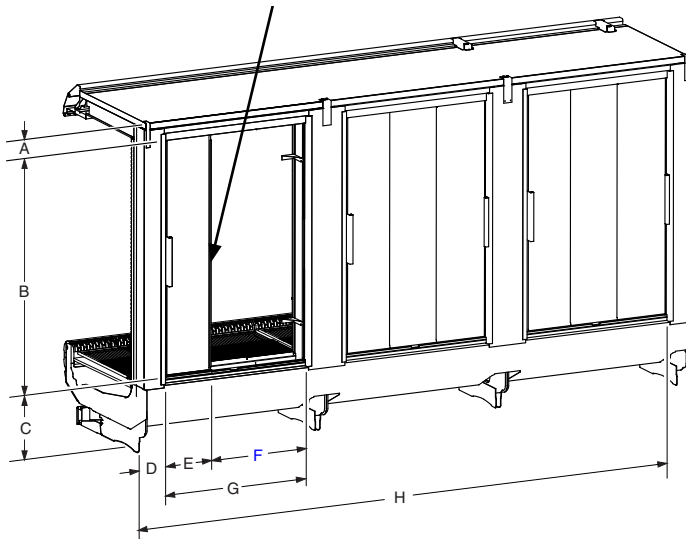

Item	ID6SUR Merchandisers			
	4ft	6ft	8ft	12ft
A	6 ¹ / ₈ (155)			
B	67 ¹ / ₂ (1724)			
C	16 ¹ / ₈ (419)			
D	5 ¹ / ₈			
E	12 ¹ / ₄ (309)	8 ¹ / ₈ (206)	12 ¹ / ₄ (309)	12 ¹ / ₄ (309)
* F	24 ⁷ / ₈ (631)	17 (430)	24 ⁷ / ₈ (631)	24 ⁷ / ₈ (631)
G	37 ¹ / ₈ (941)	25 ¹ / ₈ (636)	37 ¹ / ₈ (941)	37 ¹ / ₈ (941)
H	42 ⁵ / ₈ (1082)	66 ³ / ₄ (1694)	90 ³ / ₄ (2305)	138 ⁷ / ₈ (3526)

Item	ID5SLR Merchandisers			
	4ft	6ft	8ft	12ft
A	6 ¹ / ₈ (155)			
B	58 ¹ / ₄ (1478)			
C	19 ¹ / ₈ (484)			
D	5 ¹ / ₈			
* E	12 ¹ / ₄ (309)	8 ¹ / ₈ (206)	12 ¹ / ₄ (309)	12 ¹ / ₄ (309)
* F	24 ⁷ / ₈ (631)	17 (430)	24 ⁷ / ₈ (631)	24 ⁷ / ₈ (631)
G	37 ¹ / ₈ (941)	25 ¹ / ₈ (636)	37 ¹ / ₈ (941)	37 ¹ / ₈ (941)
H	42 ⁵ / ₈ (1082)	66 ³ / ₄ (1694)	90 ³ / ₄ (2305)	138 ⁷ / ₈ (3526)

**REAR VIEW DIMENSIONS ID5SLRS
OF CASES WITH EXTERNAL SLIDING
REAR LOADING DOORS
(4 ft, 6 ft, 8 ft, 12 ft)**

Item	ID5SLRS Merchandisers			
	4 Ft	6 Ft	8 Ft	12 Ft
A	2 ⁷ / ₈ (74)			
B	64 ¹ / ₈ (1628)			
C	16 ³ / ₈ (415)			
D	5 ¹ / ₂ (139)			
E	37 ¹ / ₈ (943)	25 ¹ / ₈ (636)	37 ¹ / ₈ (943)	37 ¹ / ₈ (943)
F	11 (279)			
G	37 ¹ / ₈ (943)	61 ¹ / ₄ (1556)	85 ¹ / ₄ (2165)	133 ³ / ₈ (3388)
H	48 ¹ / ₈ (1222)	72 ¹ / ₄ (1835)	96 ¹ / ₄ (2445)	144 ³ / ₈ (3668)

Note: Consult Cooler Close-off Kit for instructions on connecting the merchandiser to the cooler.

Rear Views

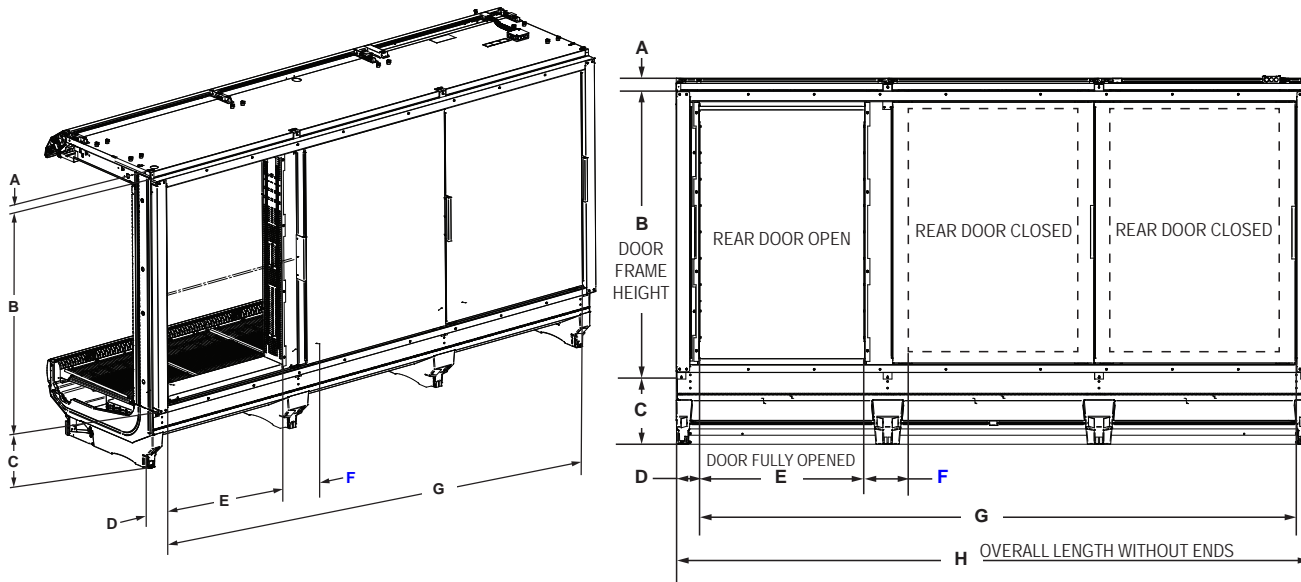

Dimensions shown as in. and (mm).

APPLY GASKETS - REAR LOAD

Refer to Pages 1-6, 1-11.

LEGEND:

A = 1/2 x 1/2 INCH GASKET

B = NEUTRAL CURING SILICONE SEALANT

C = PIN-ALIGNMENT

D = COVER-HAND RAIL JOINT



IMPORTANT:

Do not pull cases together with bolts. Cases must be moved together as close as possible. Follow sequence balloons to tighten bolts.

- Apply gasket to only one side of case joint.
- Remove end shipping braces as described on Page 1-5.
- Cases must be leveled as described on Page 1-6.
- Removed any casters - if installed.
- Install case lineup from left to right.
- Remove shelves, display racks, pans & interior back panels at the joining area.
- Insert gasket into case channels the entire length with no gaps.
- Do not stretch gasket, especially around corners.
- Do not butt gaskets, always overlap them.
- Remove paper backing after gasket has been applied.
- Perimeter gasket is required by NSF.
- Apply a continuous bead of neutral curing silicone sealant.
- Joints must be air tight to prevent formation of ice or condensation.

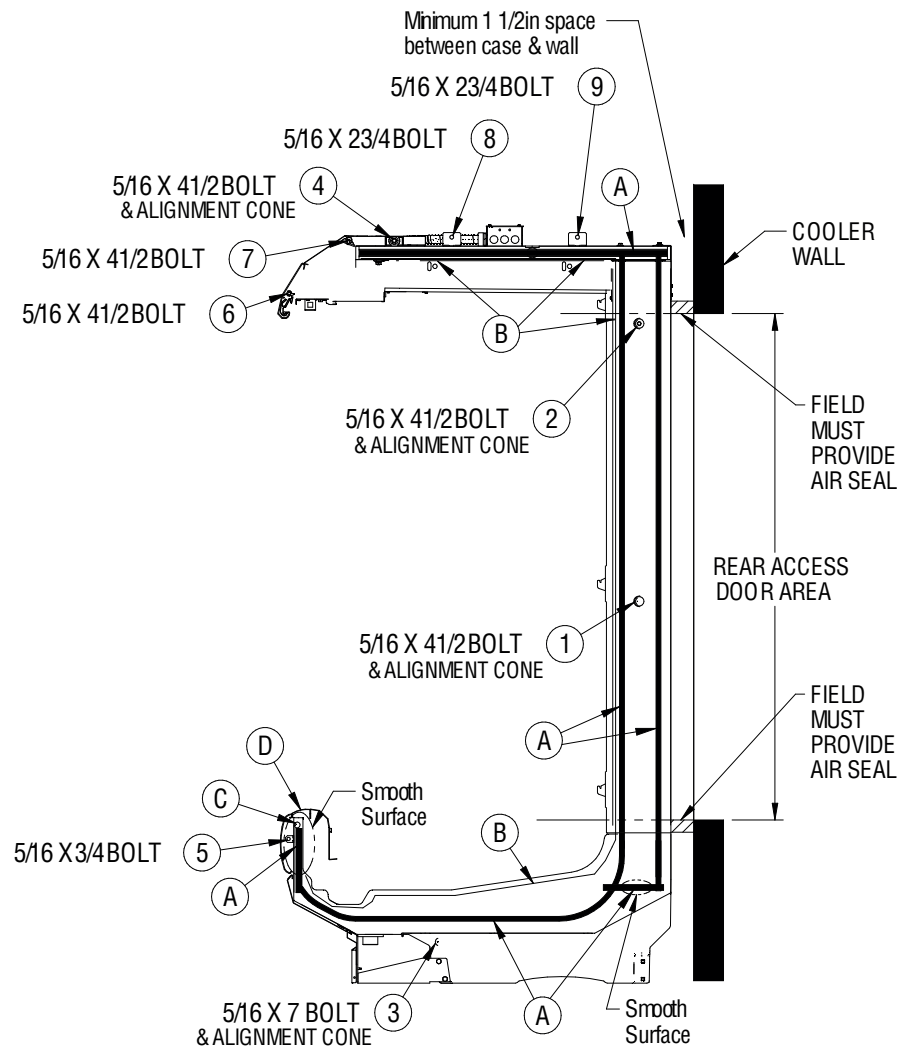

APPLY GASKETS - DOORED CASES

case bolting details begin on the next page. Refer to Page 1-6 for hardware list.

Do not pull cases together with bolts. Cases must be moved together as close as possible. Follow sequence balloons to tighten bolts.

LEGEND:

A = 1/2 x 1/2 INCH GASKET

B = NEUTRAL CURING SILICONE SEALANT

C = PIN-ALIGNMENT

F = PLATE BOTTOM DOOR RAIL ALIGNMENT

IMPORTANT:

Do not pull cases together with bolts. Cases must be moved together as close as possible. Follow sequence balloons to tighten bolts.

- Apply gasket to only one side of case joint.
- Remove end shipping braces as described on Page 1-5.
- Cases must be leveled as described on Page 1-6.
- Removed any casters - if installed.
- Install case lineup from left to right.
- Remove shelves, display racks, pans & interior back panels at the joining area.
- Insert gasket into case channels the entire length with no gaps.
- Do not stretch gasket, especially around corners.
- Do not butt gaskets, always overlap them.
- Remove paper backing after gasket has been applied.
- Perimeter gasket is required by NSF.
- Apply a continuous bead of neutral curing silicone sealant.
- Joints must be air tight to prevent formation of ice or condensation.

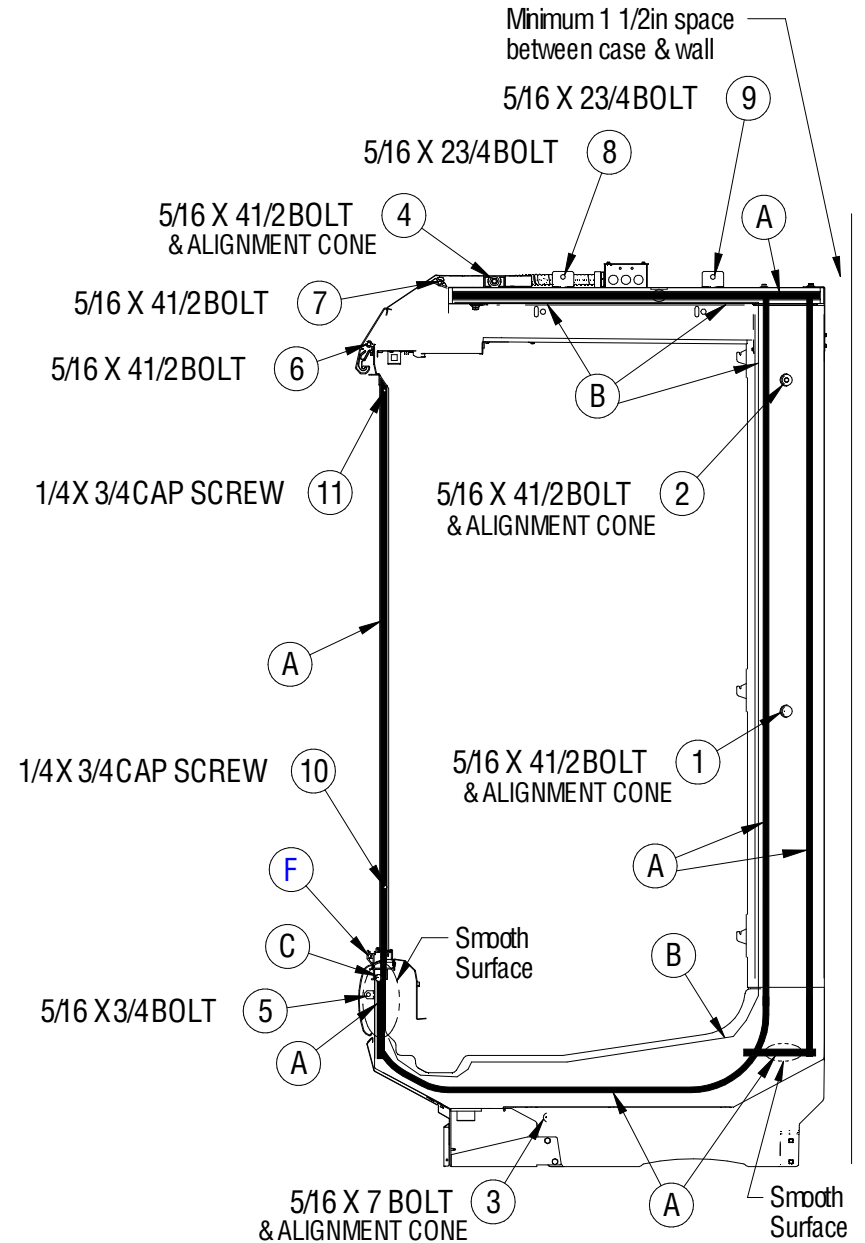

CASE JOINING DOORED AND REAR LOAD

(DOOR & REAR LOAD CASES) CONTINUED

LEGEND:

C=PIN-ALIGNMENT

F=PLATE-BOTT DOOR RAIL ALIGNMENT

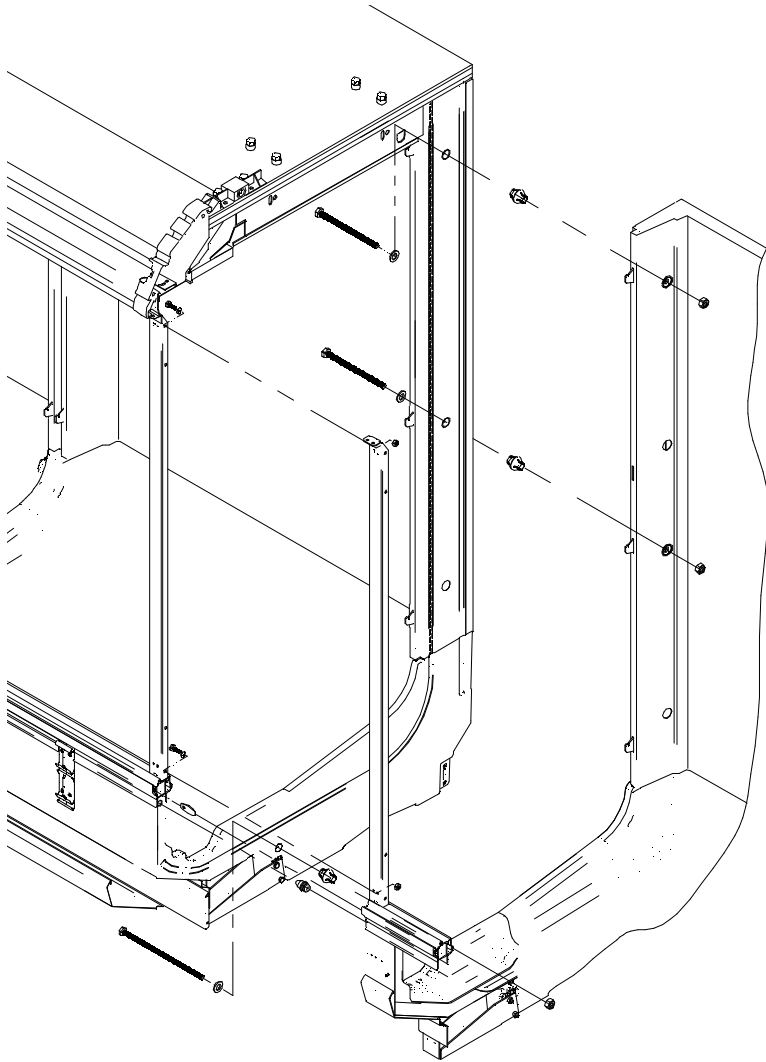

1/4 X 3/4 CAP SCREW 11

5/16 X 4 1/2 BOLT & ALIGNMENT CONE 2

1/4 X 3/4 CAP SCREW 10

5/16 X 4 1/2 BOLT & ALIGNMENT CONE 1

F

C

5/16 X 7 BOLT & ALIGNMENT CONE 3

Install 1/2" x 1/2" gasket along edge of door mullion from top to bottom of one case when joining cases.

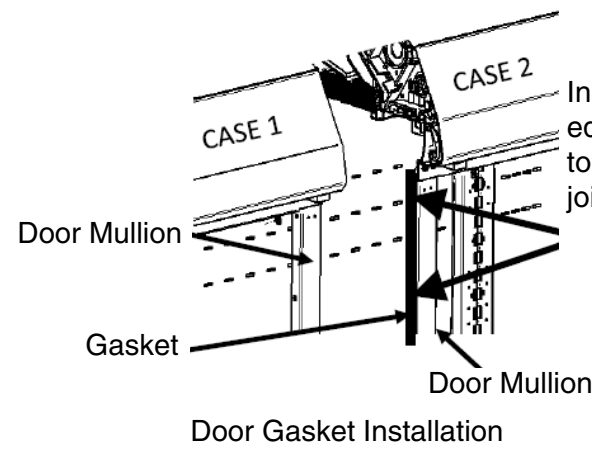

**CASE JOINING
(DOOR & REAR LOAD CASES)**

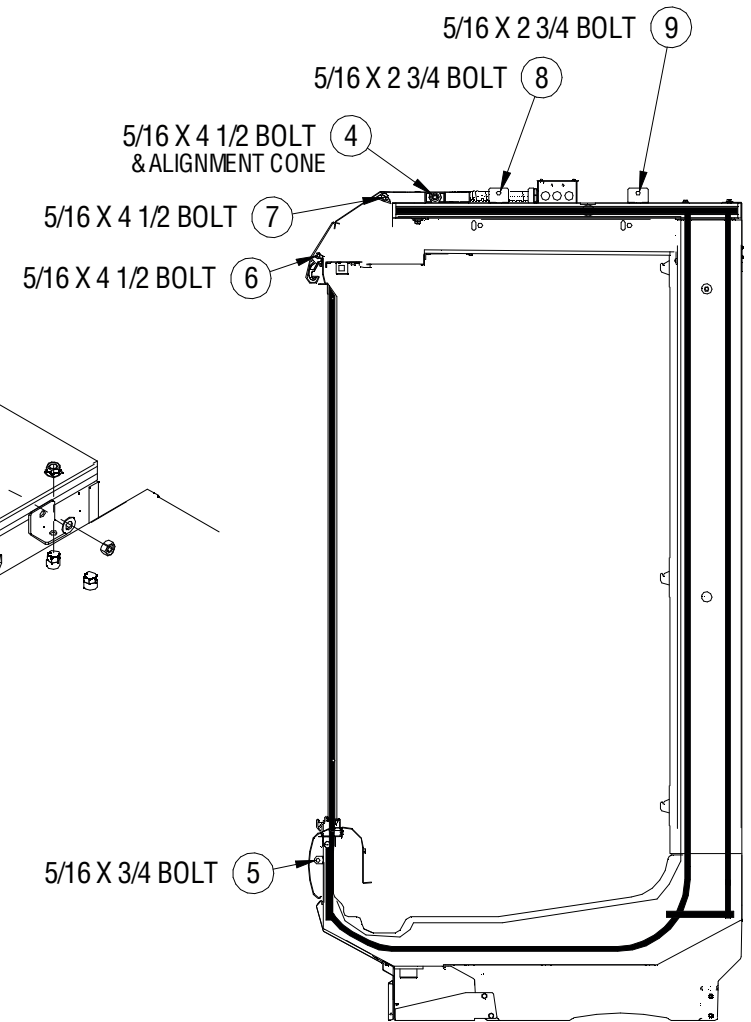
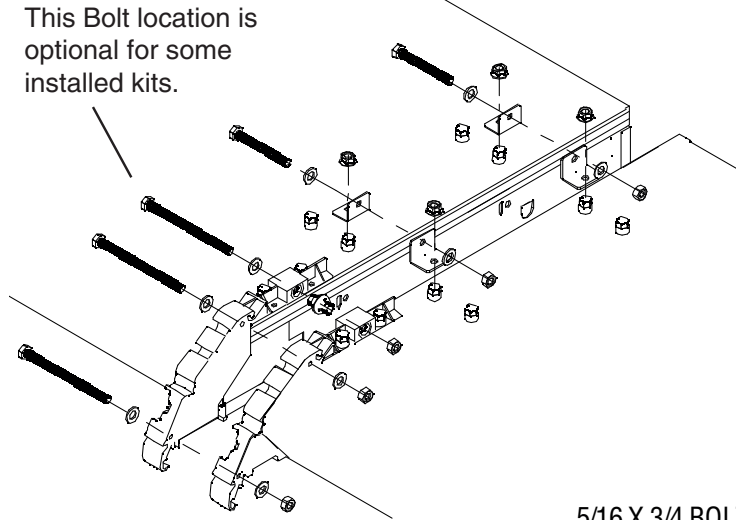
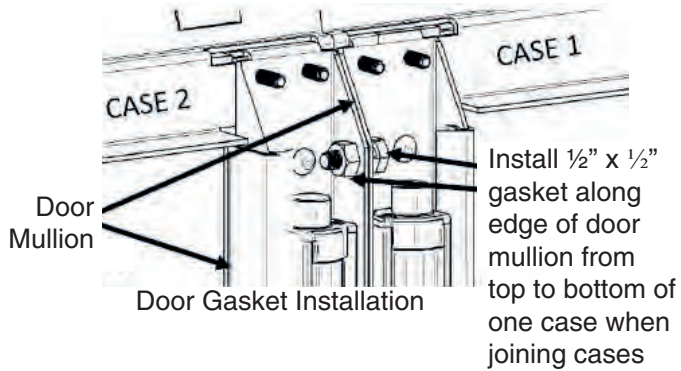
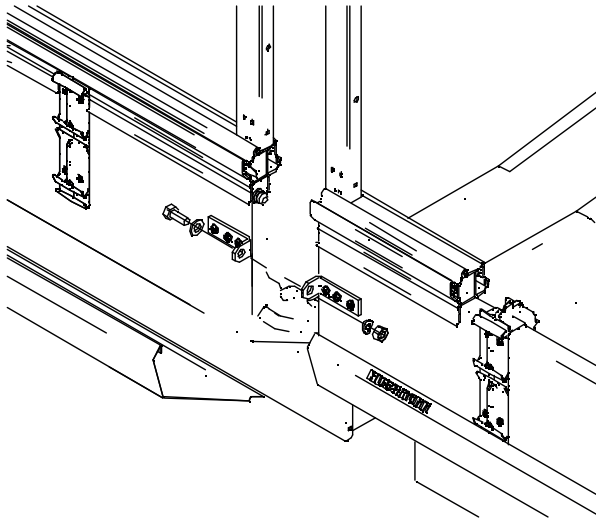

DOORS - INSTALLING, REMOVING, ADJUSTING

- A. To install a door: Lean door back, and push pin into mullion. Ensure push pins are fully seated in canopy support bracket.
- B. To remove a door: Raise door up and lift rod bottom out of bottom hinge plate hole

ADJUSTING ECOVISION DOORS

Check that all doors open and close properly.

- A. Leveling — Merchandisers must be installed level to ensure proper operation of the refrigeration system, and to ensure proper drainage of defrost water.

Glass alignment is also affected with improper leveling of the merchandisers. All steps of setting joining and case leveling attention to the glass position is critical. Do not attempt to make glass adjustments prior to case leveling.

- B. Door Adjustment — Loosen the screws A, B and C as shown below (Do not remove the screws completely).

Slide the bottom plate left and right until proper alignment is achieved. Re-tighten the screws A, B and C. Install fasteners in locations 1 and 2 as shown below.

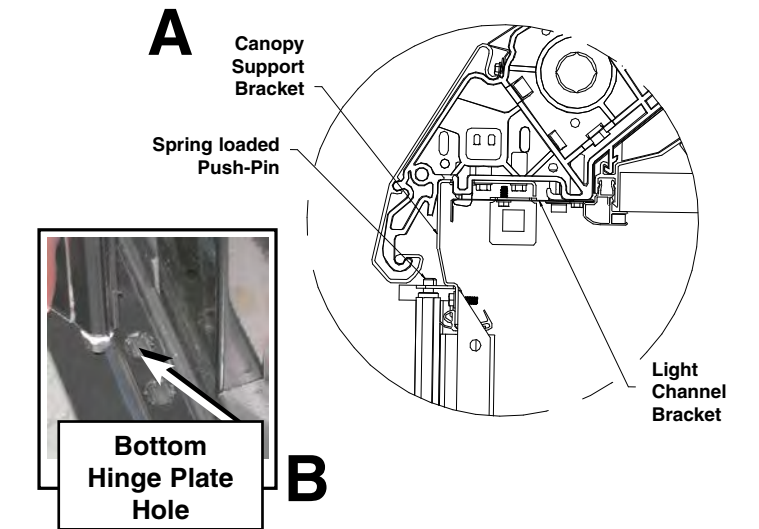

Excessive ambient conditions may cause condensation and therefore sweating of doors. Facility operators should monitor doors and floor conditions to ensure safety of persons.

EcoVision Door Alignment - Modular Bottom Hinge Plate

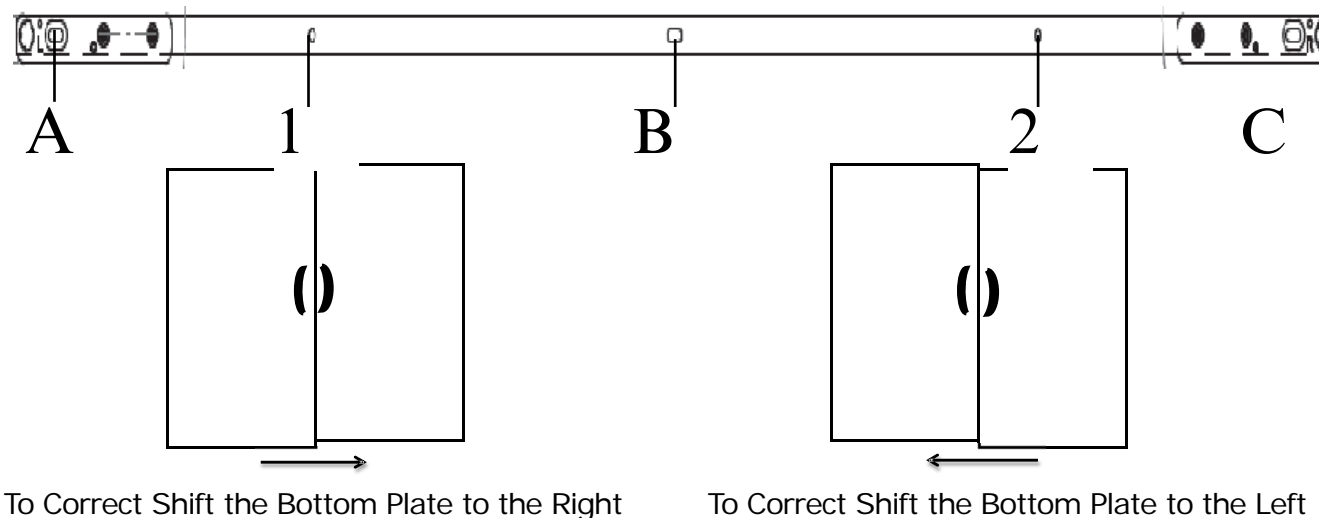

ADJUSTING DOOR CLOSING SPEED

The door's closing speed is factory adjusted, but the door may also be field adjusted.

Do the following to adjust the doors:

1. To release door tension, open the door to 90° and lift up the door from the bottom. Lift the torsion rod out of the star pattern in the bottom hinge plate. (The door should be lifted out of the star pattern in the hinge plate to prevent any damage to the star pattern.)
2. Use a ½ in. open end wrench to tighten the torsion of the door. Adjust tension with each audible click. Doors should be adjusted to 4 clicks, more if needed. Door must be properly resealed in star pattern of hinge plate after torsion tension is applied.

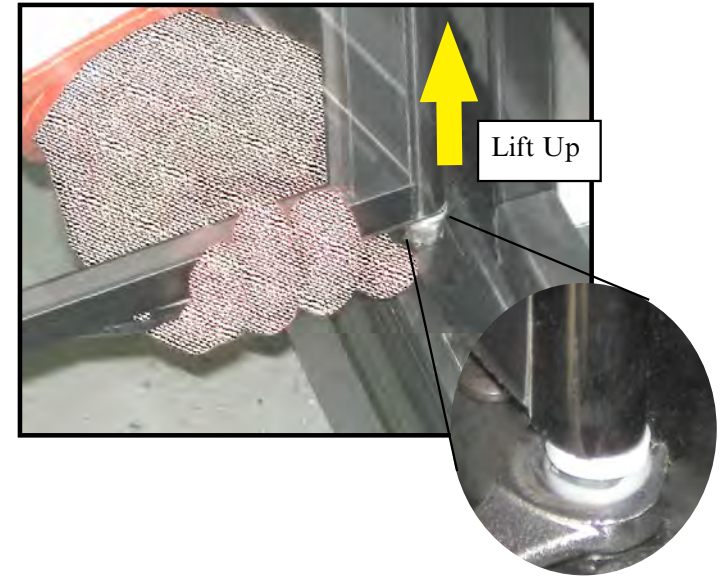

REPLACING LED MULLION LIGHT BARS

LED vertical mullion lights are an available lighting option for EcoVision doors. Center fixtures illuminate the middle of the case, and the end fixtures illuminate the ends, or sides of the case.

These LEDs have different shaped lenses. They are not to be interchanged. Contact your Hussmann representative to order replacements.

The light bars are attached to the door mullions with mounting clips, and can be replaced similar to the canopy lights — just remove them from the mounting clips, and connect new wires at quick connect.

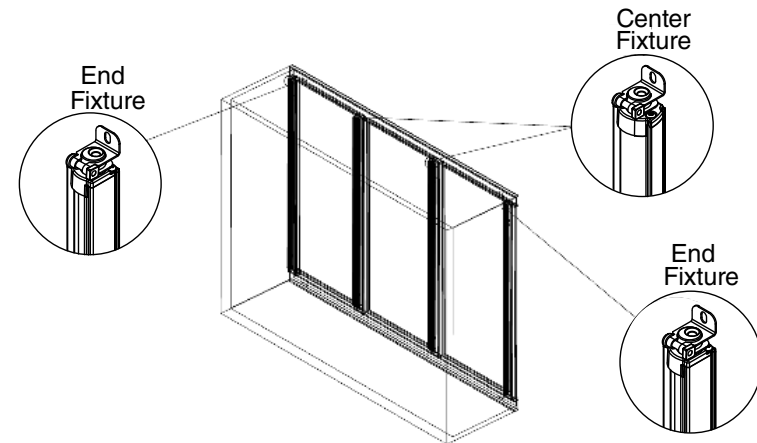

INSTALLING END ASSEMBLIES

Remove shipping brace. Brace screws will be replaced with shorter screws found in packout kit. Ensure nut retainers are in place. Apply Gaskets and Silicone to End Frame.

Apply ½ x ½ in. (12.7 mm) x (12.7 mm) gaskets into the case channels. Check that the gasket is properly inserted into the entire length of the channels with no gaps. Apply silicone between case end cap and end.

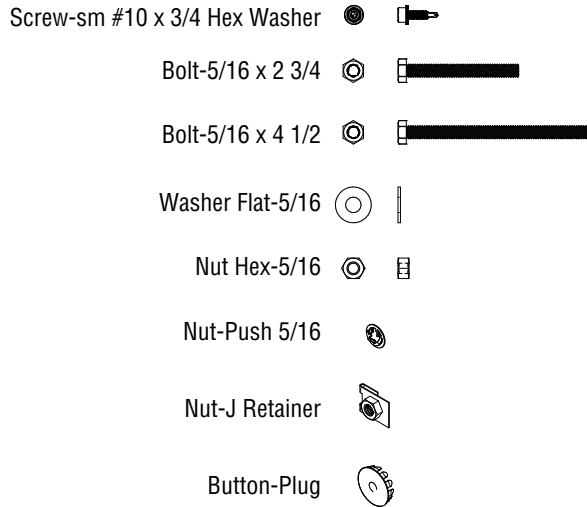

FIELD INSTALLED HARDWARE	Multi Deck Qty/Each	Convertible Qty/Each	Single Deck Qty/Each	View End Multi Deck Qty/Each
Description				
SEALER SILICONE ADHESIVE	1	1	1	1
GASKET 1/2 X 1/2 X 180	1	1	1	1
SCREW SM 10-16X3/4 HX WASHER	1	1	1	N/A
BOLT 5/16 x 2 3/4 GRADE 5 ZINC PLATED TAP*	4	2	1	5
BOLT- TAP, 5/16 x 4 1/2, STEEL, ZINC FINISH, GR5	1	1	1	1
WASHER-FLAT 5/16" ZINC*	7	4	2	8
NUT-HEX 5/16 STEEL ZINC FINISH GRADE 8*	3	2	2	4
NUT-PUSH 5/16" RETAINER STEEL ZINC*	2	1	1	2
NUT-J RETAINER 5/16*	2	1	N/A	2
BUTTON-PLUG 7/8 DIA*	5	3	2	6

*Quantities may vary depending on which type of end is to be placed on case.

IMPORTANT:

Do not pull cases together with bolts. Cases must be moved together as close as possible. Follow sequence balloons to tighten bolts.

- Apply gasket to only one side of case joint.
- Remove end shipping braces as described on Page 1-5.
- Cases must be leveled as described on Page 1-6.
- Removed any casters - if installed.
- Install case lineup from left to right.
- Remove shelves, display racks, pans & interior back panels at the joining area.
- Insert gasket into case channels the entire length with no gaps.
- Do not stretch gasket, especially around corners.
- Do not butt gaskets, always overlap them.
- Remove paper backing after gasket has been applied.
- Perimeter gasket is required by NSF.
- Apply a continuous bead of neutral curing silicone sealant.
- Joints must be air tight to prevent formation of ice of condensation.

CASE END INSTALLATION

MULTI-DECK (REAR-LOAD & DOOR)

Refer to detail views

LEGEND:

A = 1/2 x 1/2 INCH GASKET

B = NEUTRAL CURING SILICONE SEALANT

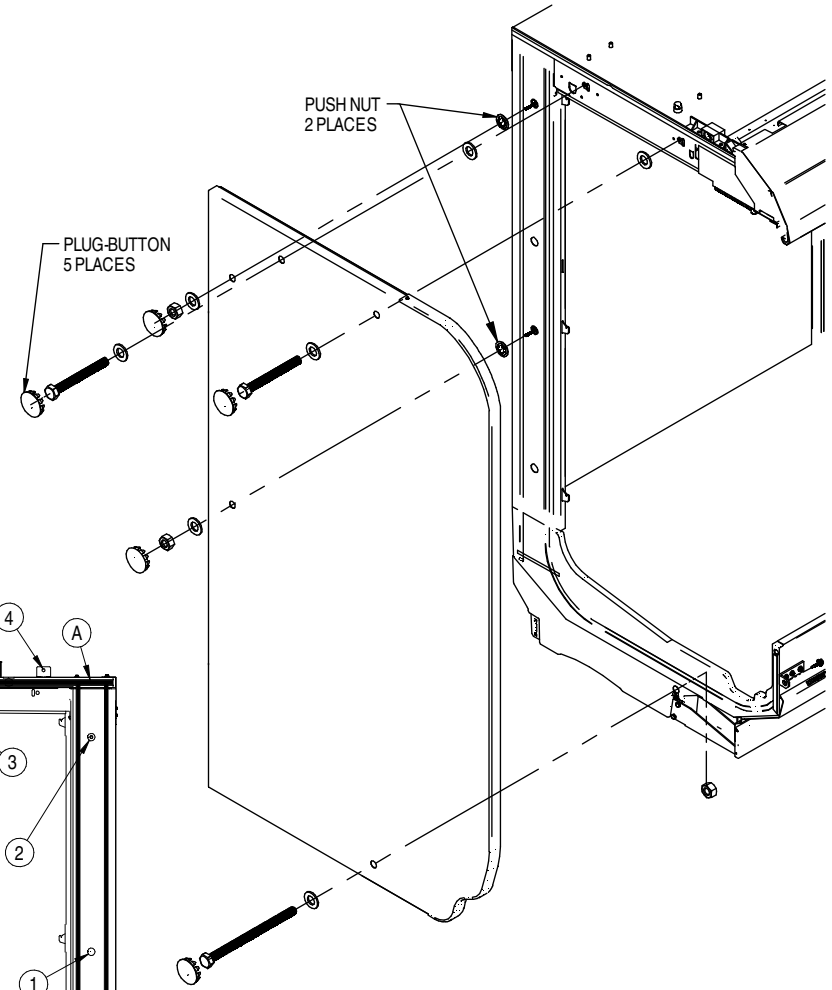
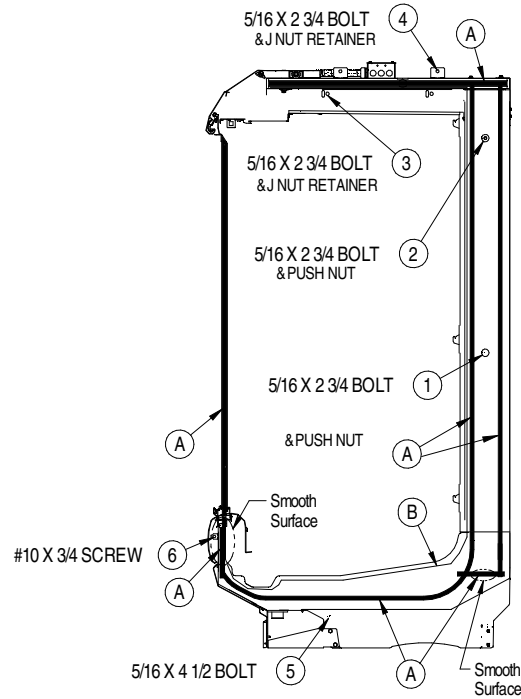
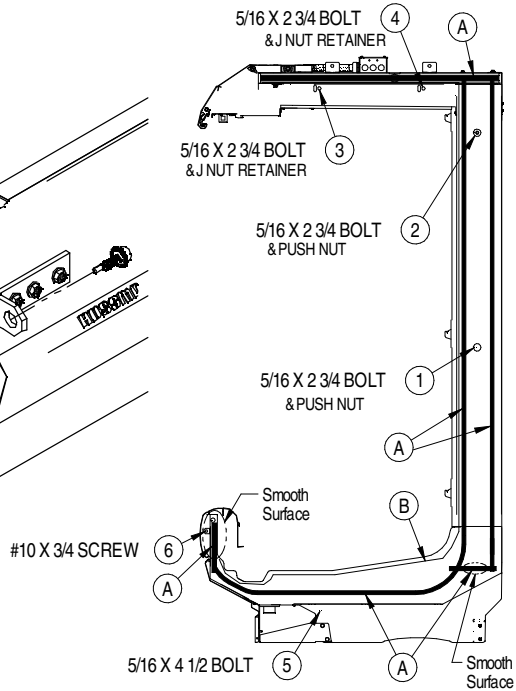
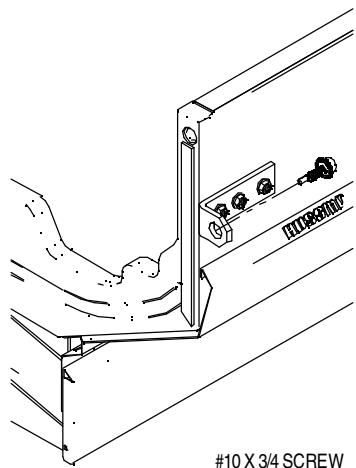
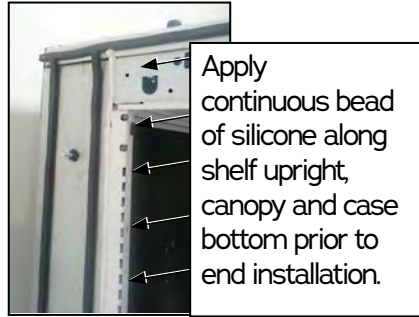

CASE VIEW END INSTALLATION

MULTI-DECK (REAR-LOAD & DOOR)

Refer to detail views

LEGEND:

A = 1/2 x 1/2 INCH GASKET

B = NEUTRAL CURING SILICONE SEALANT

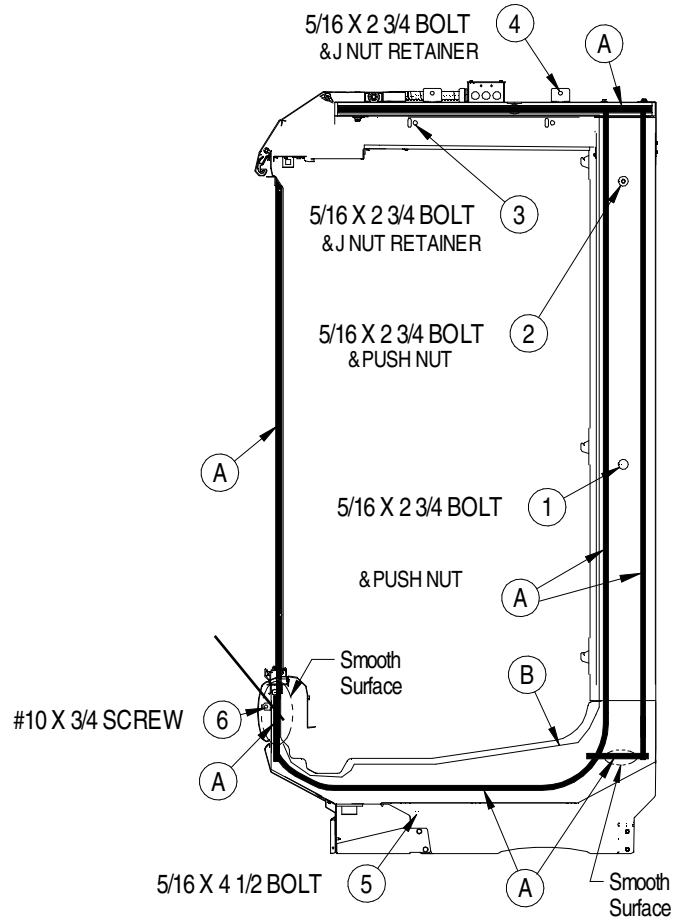
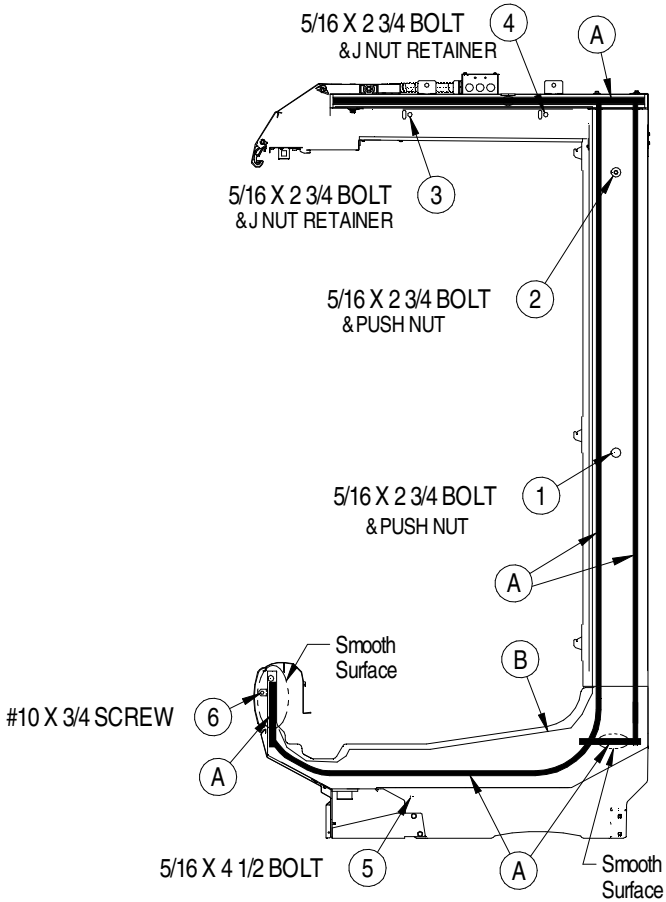
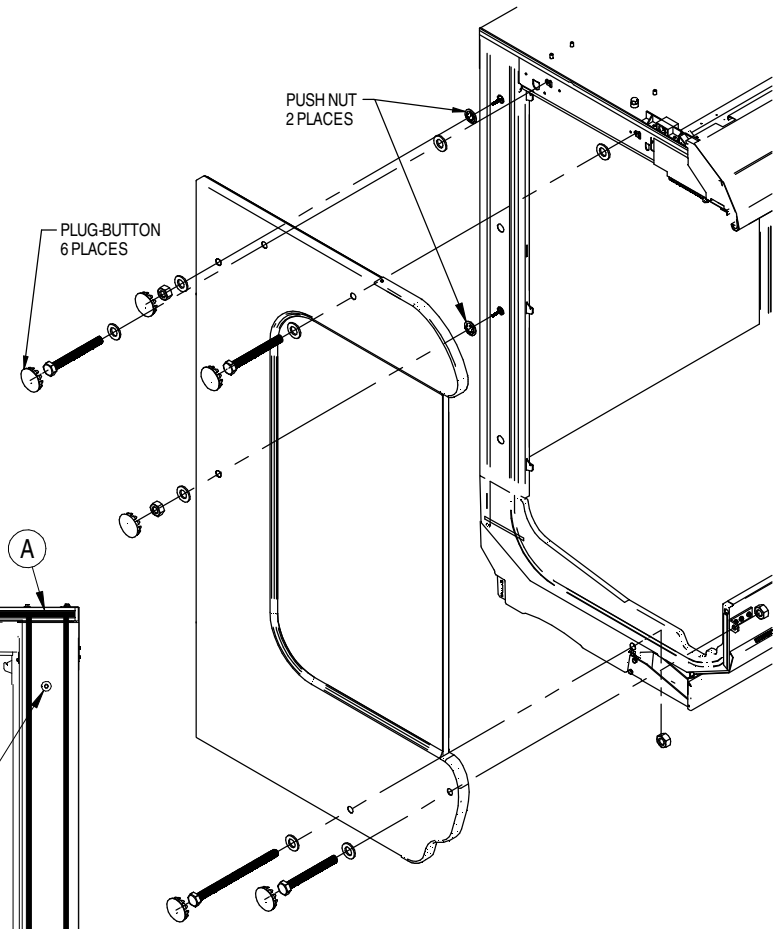
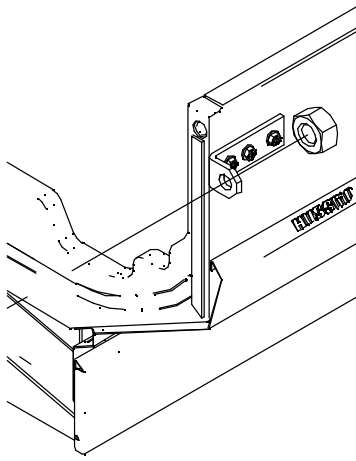

CONVERTIBLE CASE END INSTALLATION

Refer to detail views

LEGEND:

A = 1/2 x 1/2 INCH GASKET

B = NEUTRAL CURING SILICONE SEALANT

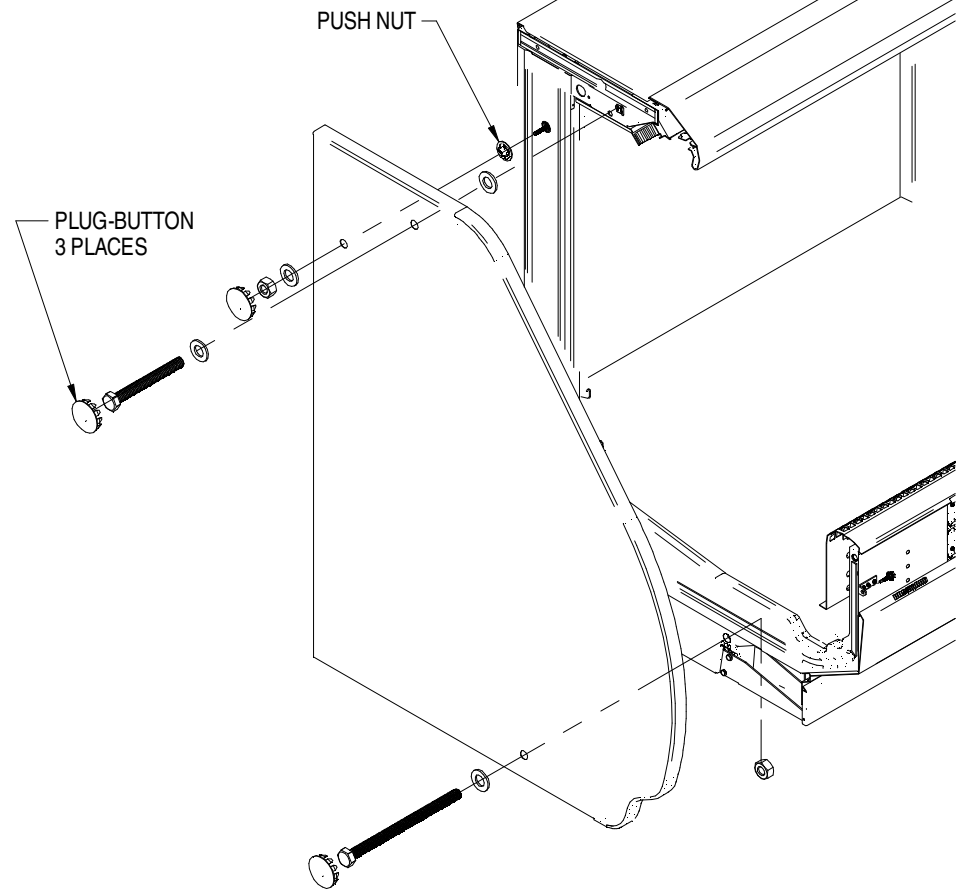
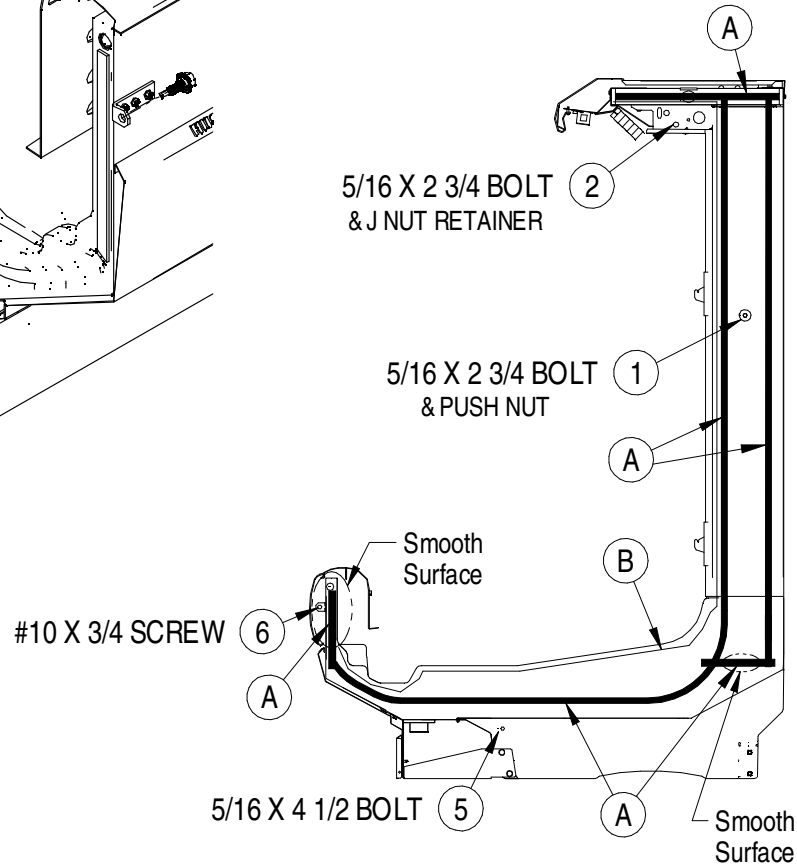
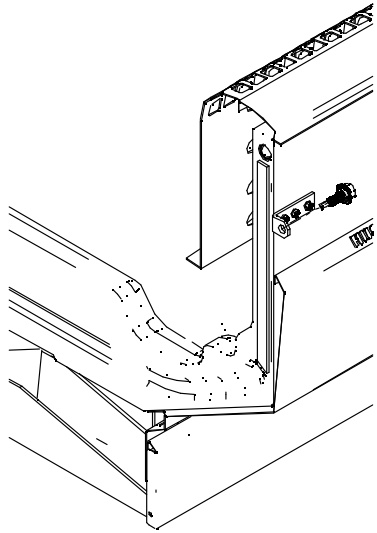

SINGE DECK CASE END INSTALLATION

Refer to detail views

LEGEND:

A = 1/2 x 1/2 INCH GASKET



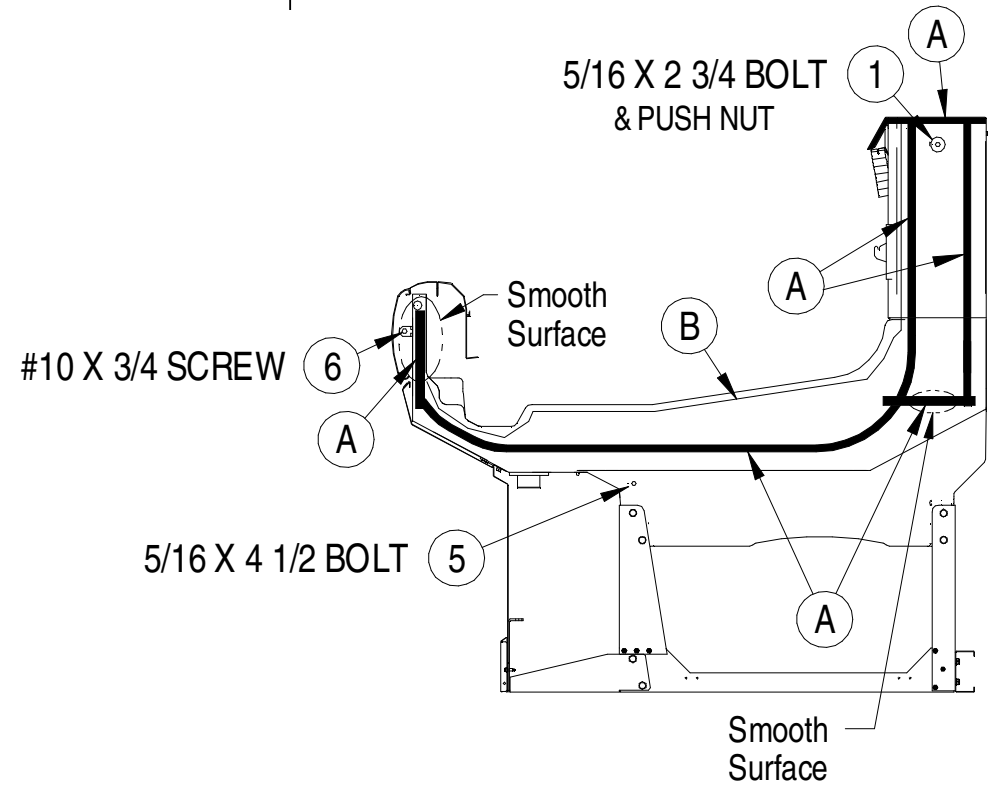
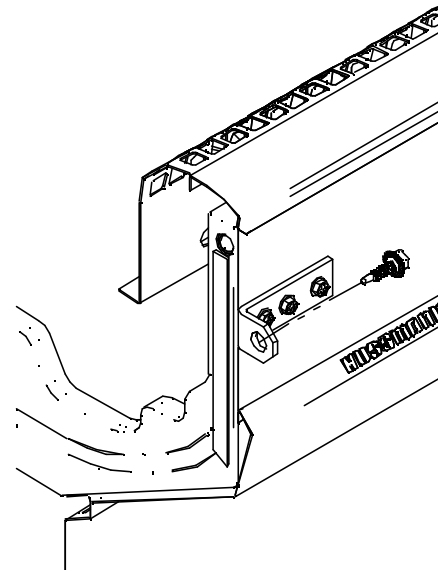
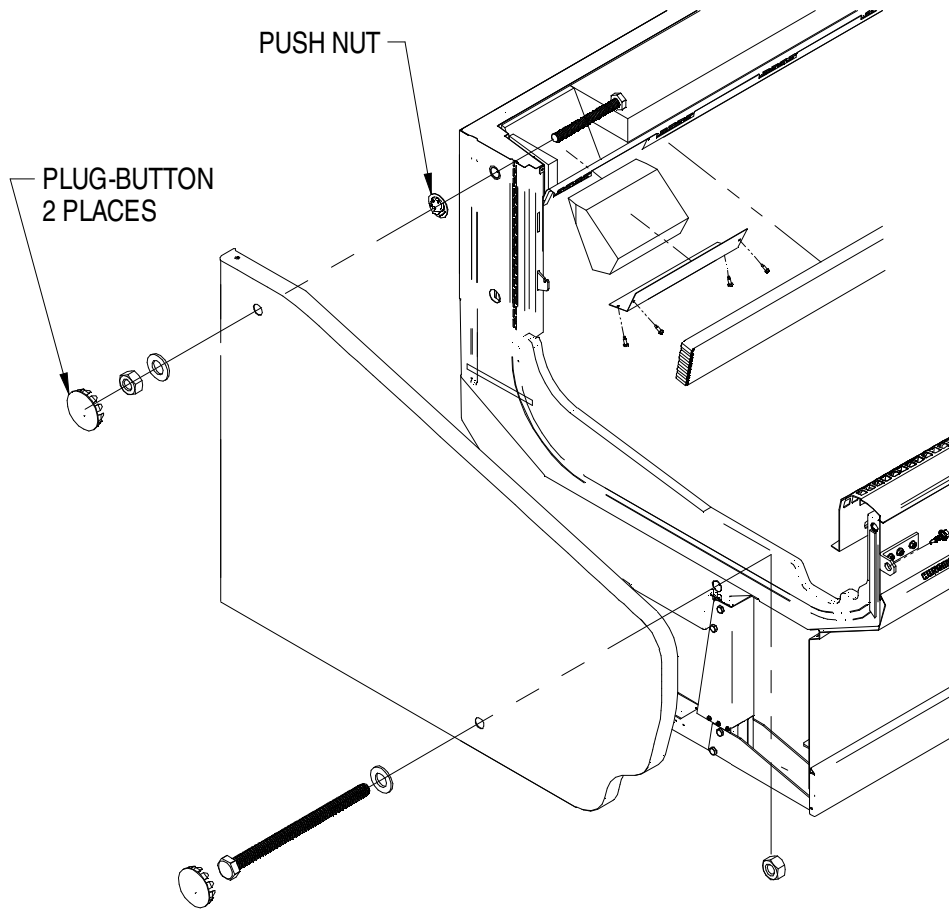

















B = NEUTRAL CURING SILICONE SEALANT



PARTITION HARDWARE

Remove shipping brace. Brace screws will be replaced with shorter screws found in packout kit. Ensure Nut Retainers are in place. Apply Gaskets and Silicone to End Frame.

Apply ½ x ½ in. (12.7 mm) x (12.7 mm) gaskets into the case channels. Check that the gasket is properly inserted into the entire length of the channels with no gaps. Apply silicone between case end cap and end.

- Screw-Sheet Metal #8 x 5/8 
- Screw-sm #10 x 3/4 Hex Washer 
- Bolt-1/4 x 1 1/2 
- Bolt-1/4 x 2 1/4 
- Bolt-1/4 x 4 
- Bolt-5/16 x 2 3/4 
- Bolt-5/16 x 4 1/2 
- Bolt-5/16 x 7 
- Bolt-5/16 x 8 
- Washer Flat-1/4 
- Washer Flat-5/16 
- Nut Hex-5/16 
- Nut Hex-3/8 Serr Flange 
- Nut-Push 5/16 
- Nut-J Retainer 
- Bracket-Case Joining 
- Bracket-Canopy (Alt Applications) 
- Bracket-Unibody (Alt Applications) 
- Button-Plug 
- Bracket-Closeoff Splashguard 
- Closeoff-Splashguard 

Description	Alt Canopy Applications	Multi Deck/Door Same Case Qty/ Each	Multi Deck/Door Different Case Qty/ Each	Convertible Different Case Qty/ Each
SEALER SILICONE ADHESIVE	Refer to Multi Deck Different Case	2	2	2
GASKET 1/2 X 1/2 X 180	Refer to Multi Deck Different Case	2	2	2
SCREW-SHEET METAL #8 X 5/8 PHIL HX HD	3 or 4	1	1	1
SCREWSM10-16X3/4 HX WASHER	1	2	2	2
BOLT HEX 1/4 x 1 1/2	Refer to Multi Deck Different Case	N/A	2	N/A
BOLT HEX 1/4 x 2 1/4*	1	N/A	2	2
BOLT HEX 1/4 x 4.0	Refer to Multi Deck Different Case	N/A	1	N/A
BOLT HEX 5/16 x 2 3/4*	Refer to Multi Deck Different Case	1	4	2
BOLT-HEX 5/16 x 4 1/2	Refer to Multi Deck Different Case	2	1	N/A
BOLT-HEX 5/16 x 7.0*	Refer to Multi Deck Different Case	2	N/A	N/A
BOLT-HEX 5/16 x 8.0	Refer to Multi Deck Different Case	1	N/A	1
WASHER-FLAT 1/4*	1	N/A	5	2
WASHER-FLAT 5/16*	Refer to Multi Deck Different Case	8	5	4
NUT-HEX 5/16*	Refer to Multi Deck Different Case	7	3	4
NUT-HEX 3/8-24 SERRATED FLANGE	1	4	2	N/A
NUT-PUSH5/16* RETAINERSTEEL ZINC*	Refer to Multi Deck Different Case	2	N/A	N/A
NUT-J RETAINERS5/16*	Refer to Multi Deck Different Case	1	2	1
BRACKET-CASE JOINING	N/A	4	2	N/A
BRACKET-CANOPY (ALT APPLICATIONS)	1	N/A	N/A	N/A
BRACKET-UNIBODY (ALT APPLICATIONS)	1	N/A	N/A	N/A
BUTTON-PLUG7/8 DIA*	Refer to Multi Deck Different Case	N/A	2	1
BRACKET-CLOSEOFF SPLASHGUARD	Refer to Multi Deck Different Case	1	1	1
CLOSEOFF-SPLASHGUARD	Refer to Multi Deck Different Case	1	1	1

*Quantities may vary depending on which type of end is to be placed on case.

IMPORTANT:

Do not pull cases together with bolts. Cases must be moved together as close as possible. Follow sequence balloons to tighten bolts.

- Apply gasket to only one side of case joint.
- Remove end shipping braces as described on Page 1-5.
- Cases must be leveled as described on Page 1-6.
- Removed any casters - if installed.
- Install case lineup from left to right.
- Remove shelves, display racks, pans & interior back panels at the joining area.
- Insert gasket into case channels the entire length with no gaps.
- Do not stretch gasket, especially around corners.
- Do not butt gaskets, always overlap them.
- Remove paper backing after gasket has been applied.
- Perimeter gasket is required by NSF.
- Apply a continuous bead of neutral curing silicone sealant.
- Joints must be air tight to prevent formation of ice or condensation.

SAME CASE PARTITIONS

MULTIDECK (REAR LOAD & DOOR)

Refer to detail views.

LEGEND:

A = 1/2 x 1/2 INCH GASKET

B = NEUTRAL CURING SILICONE SEALANT

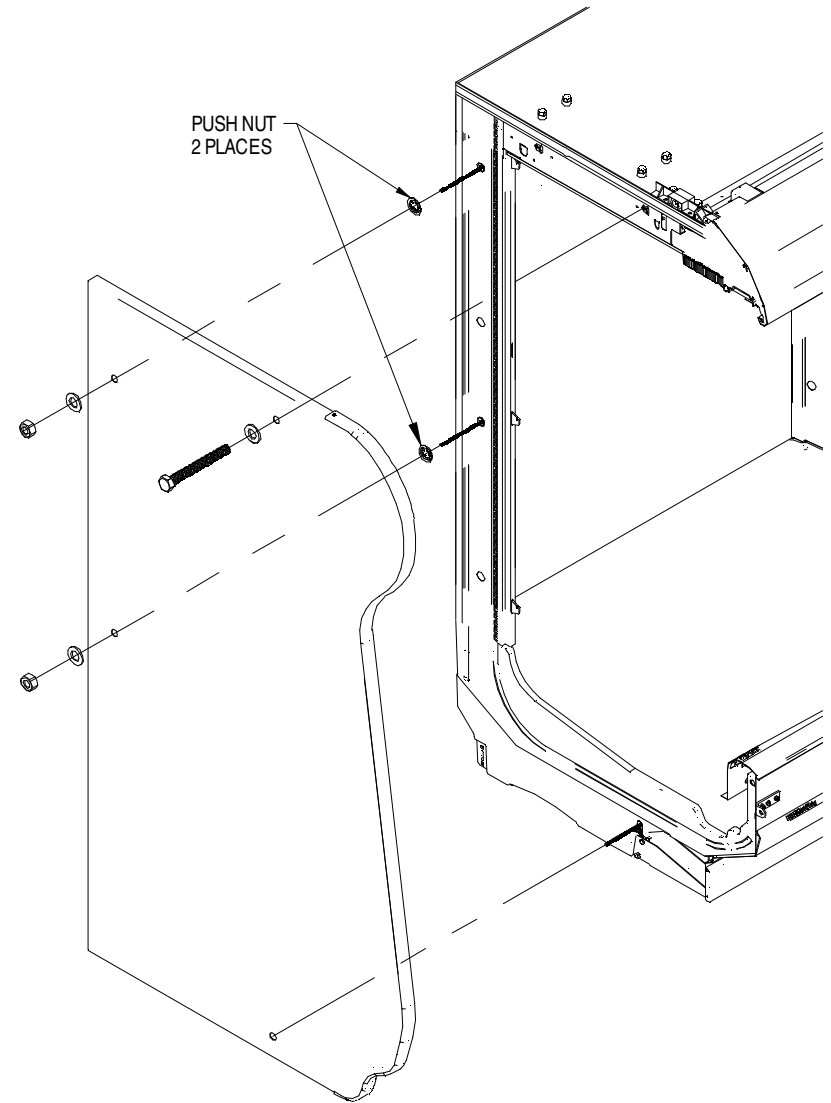
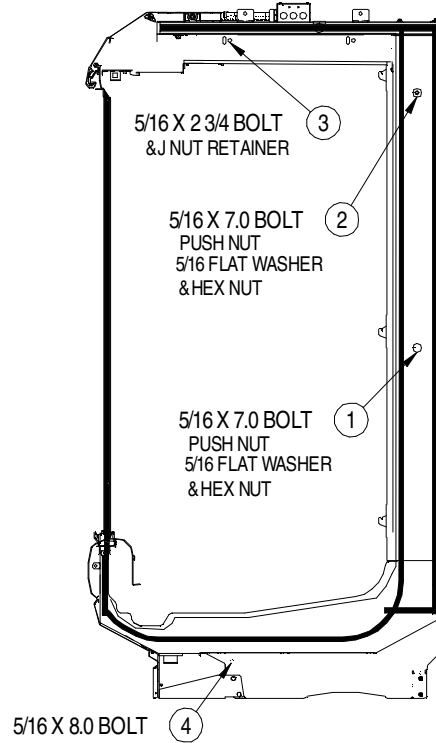
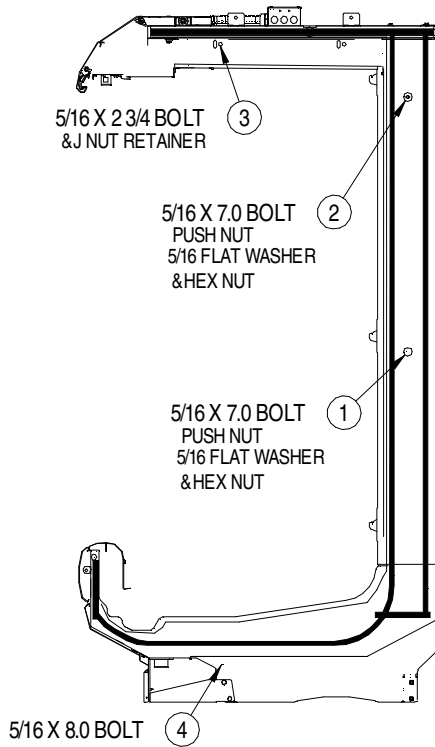

MULTI DECK (REAR-LOAD & DOOR)
 SAME CASE PARTITIONS CONTINUED
 Refer to detail views.

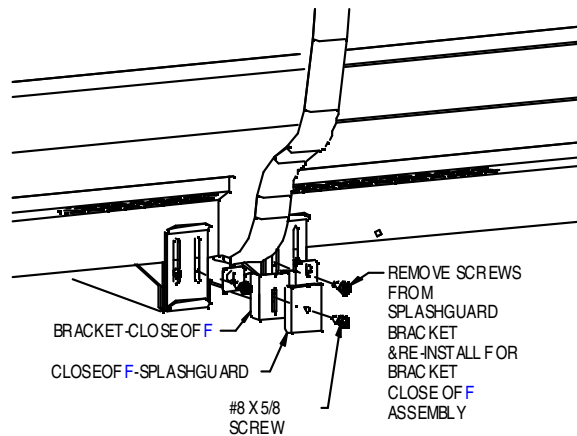
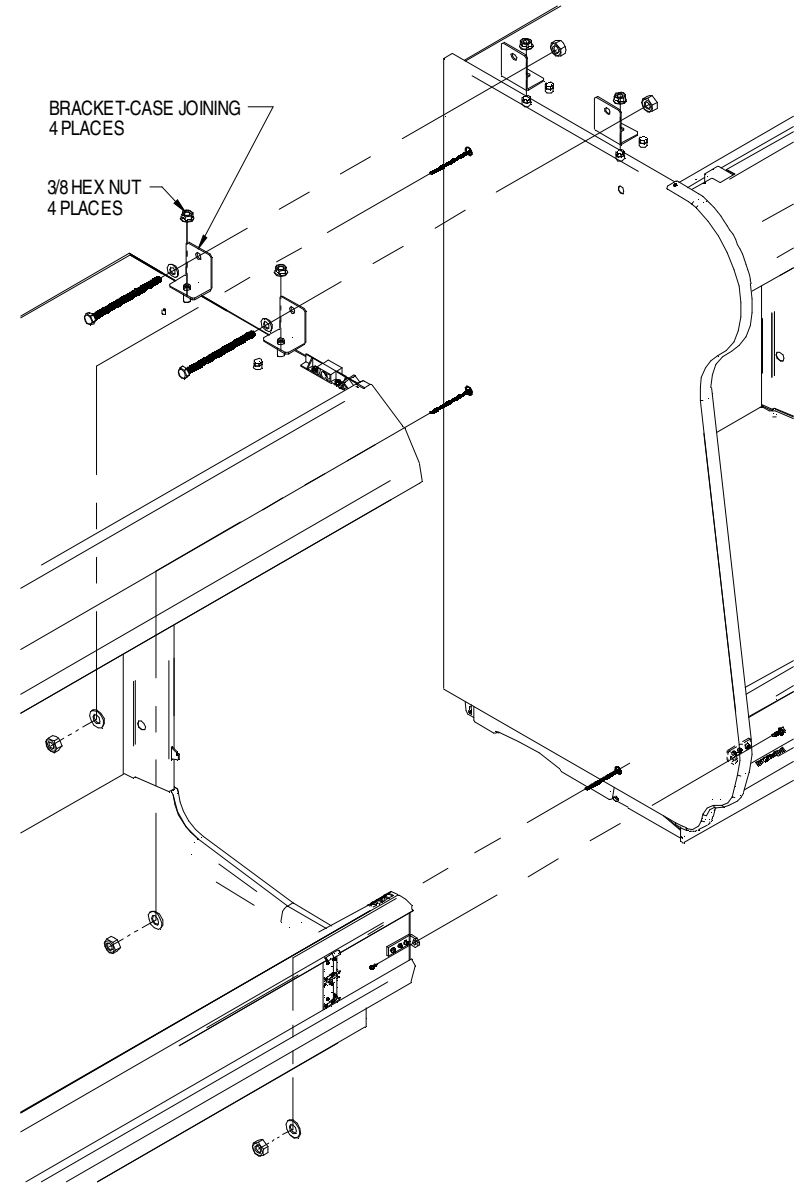
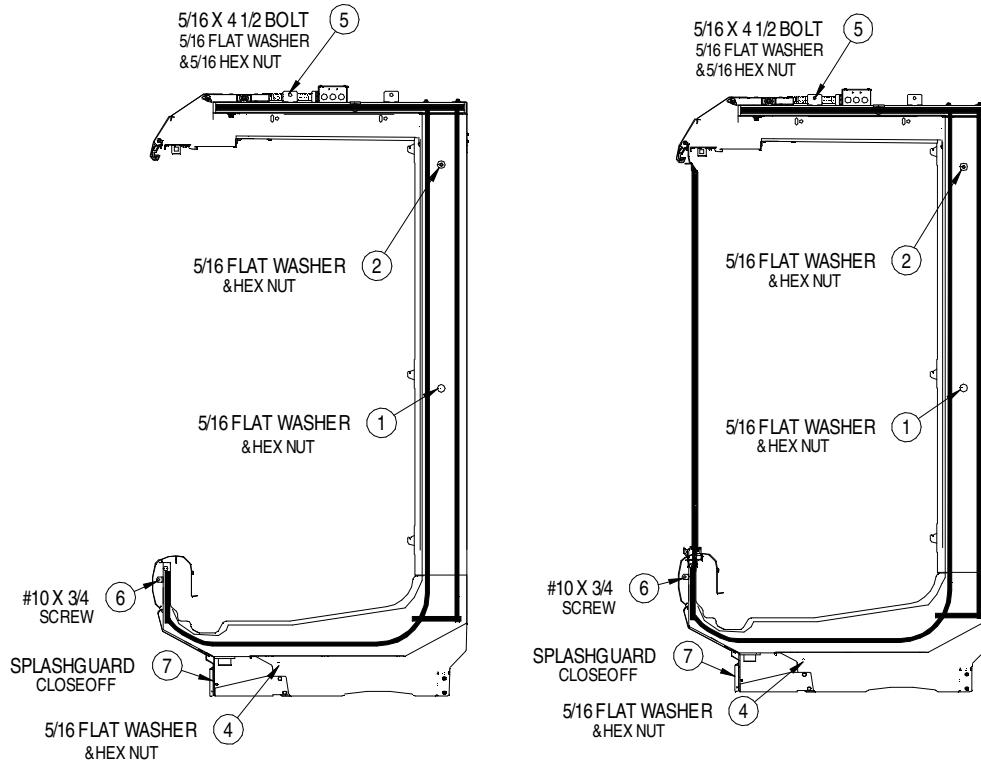

DIFFERENT CASE PARTITIONS

MULTIDECK (REAR LOAD & DOOR)

Refer to detail views.

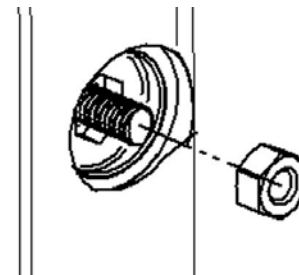
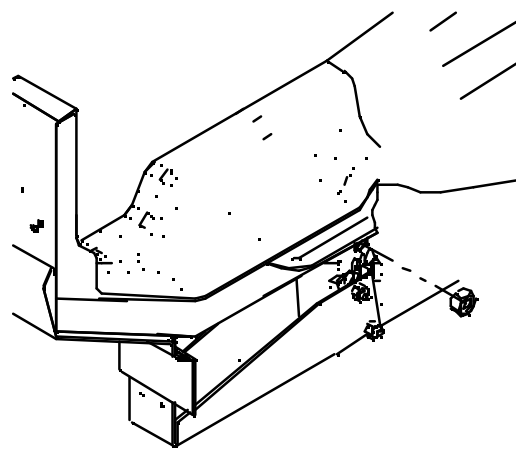
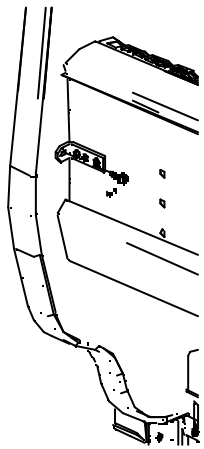
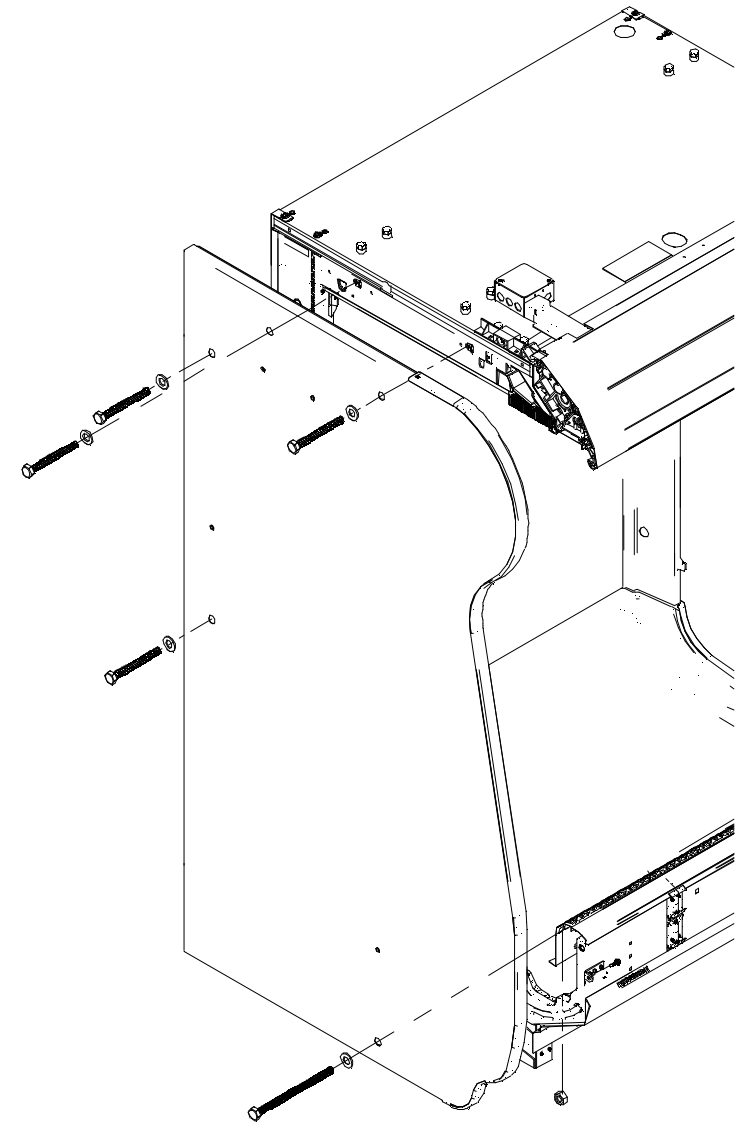
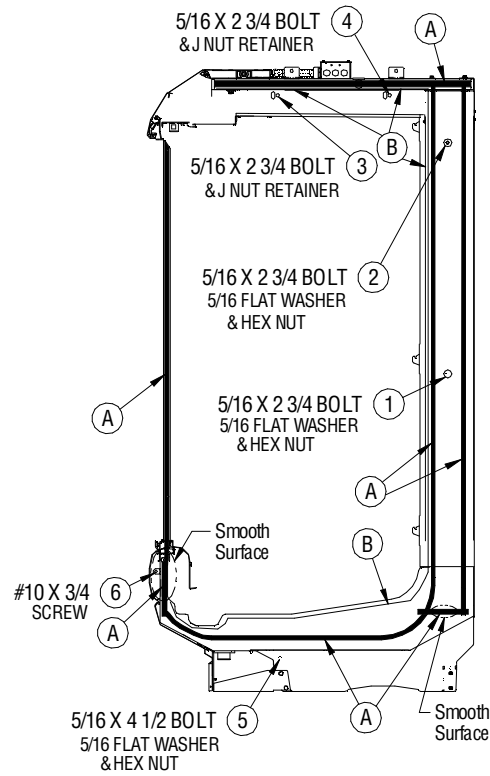
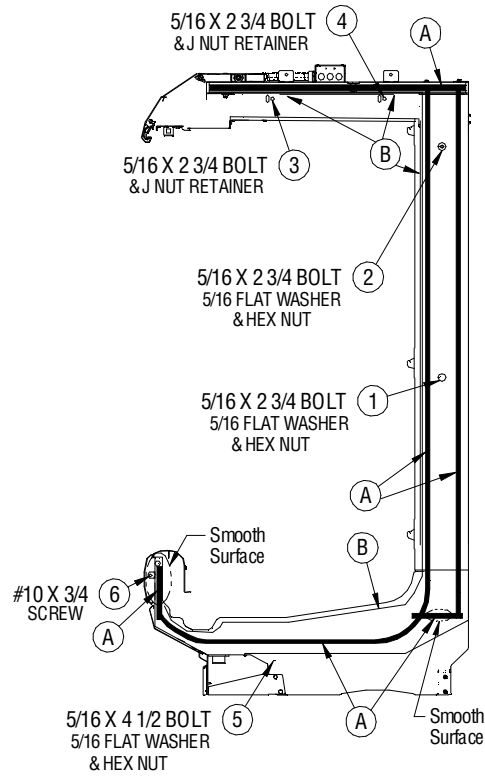

MULTIDECK (REAR-LOAD & DOOR)
DIFFERENT CASE PARTITIONS
CONTINUED

Refer to detail views.

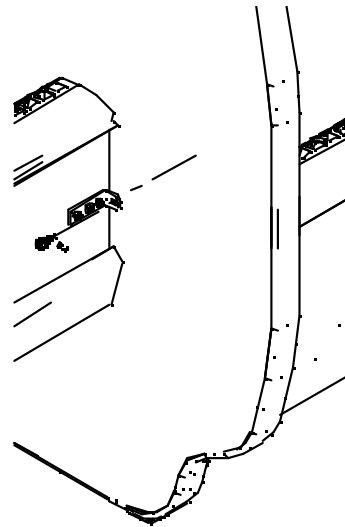
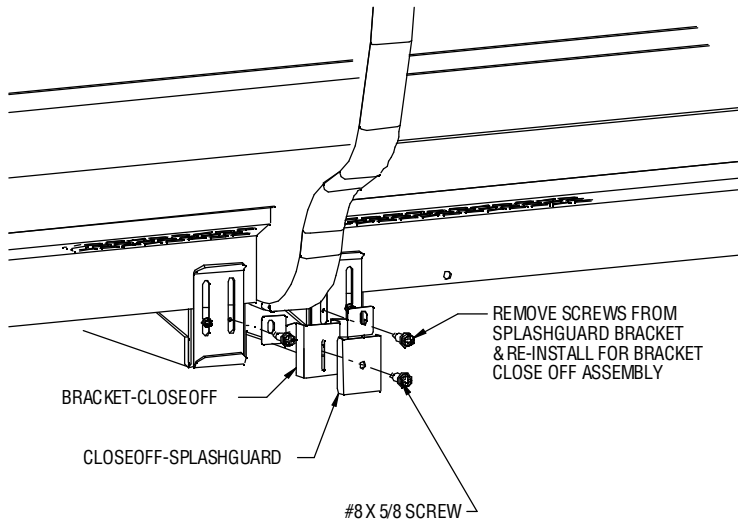
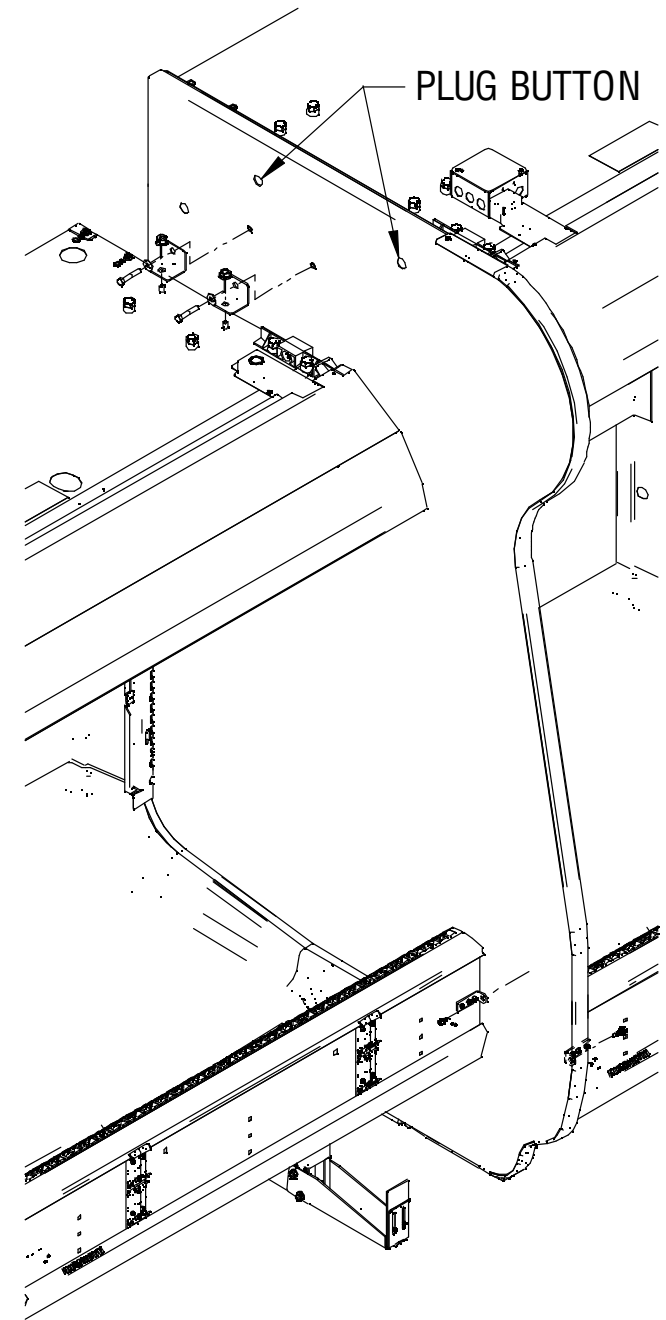
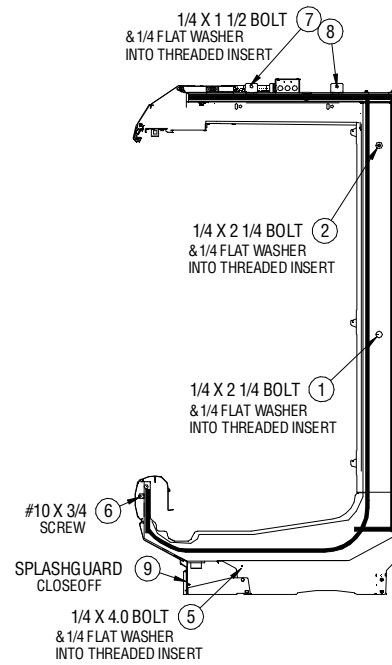
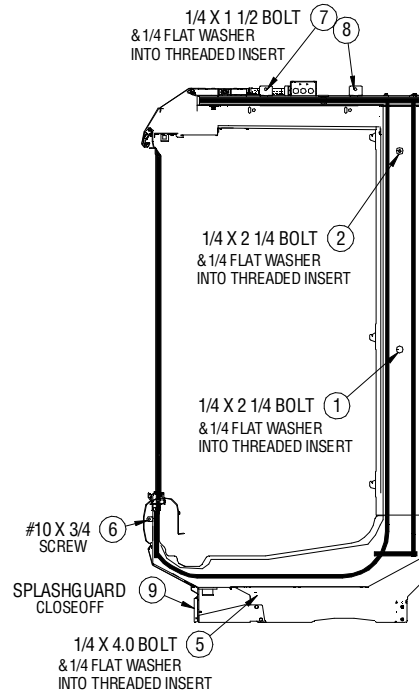

DIFFERENT CASE PARTITIONS MULTI-DECK (REAR-LOAD & DOOR)
ALTERNATIVE CANOPY APPLICATIONS
CONTINUED

Refer to detail views.

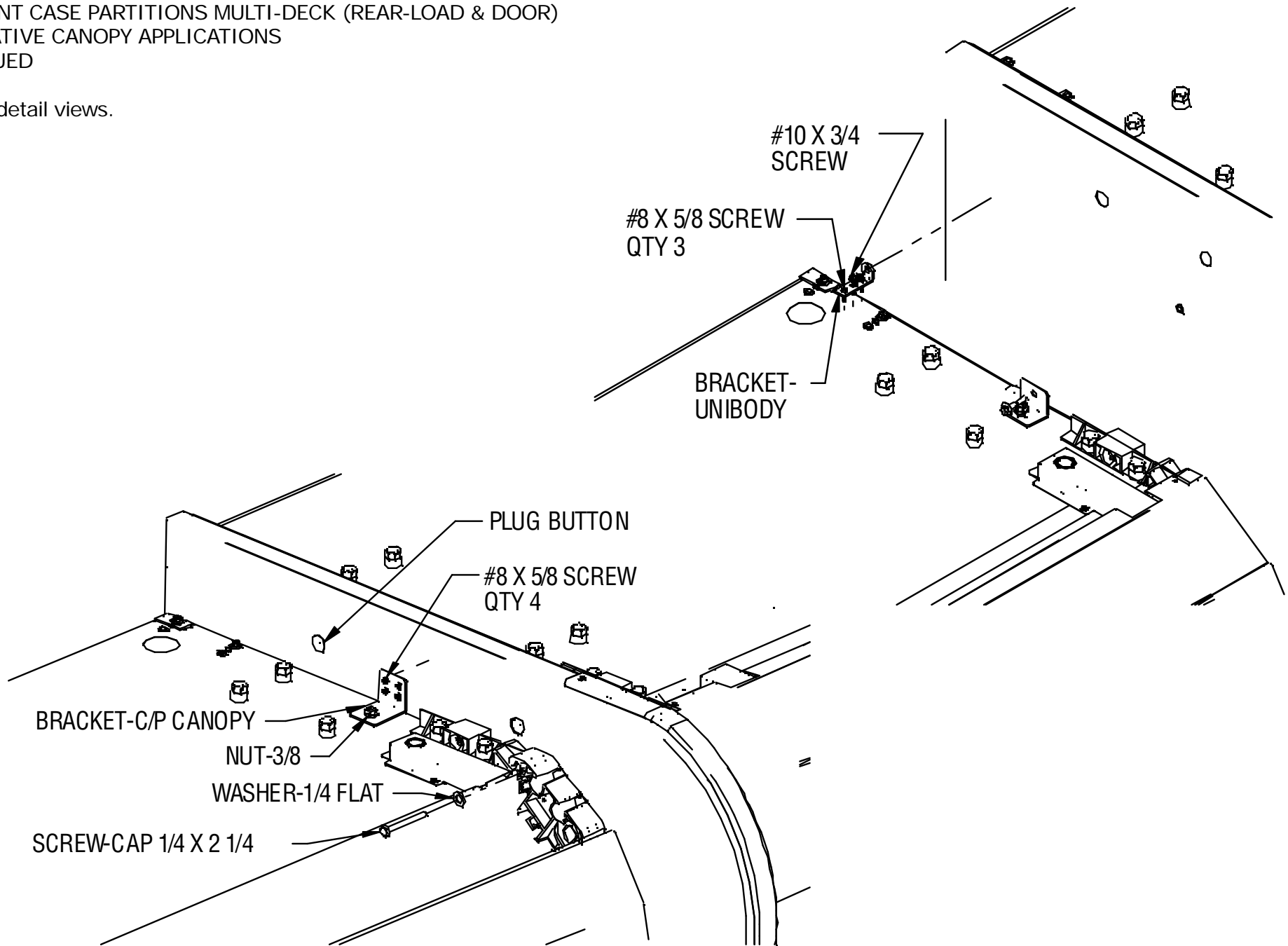

CONVERTIBLE DIFFERENT CASE PARTITIONS

Refer to detail views.

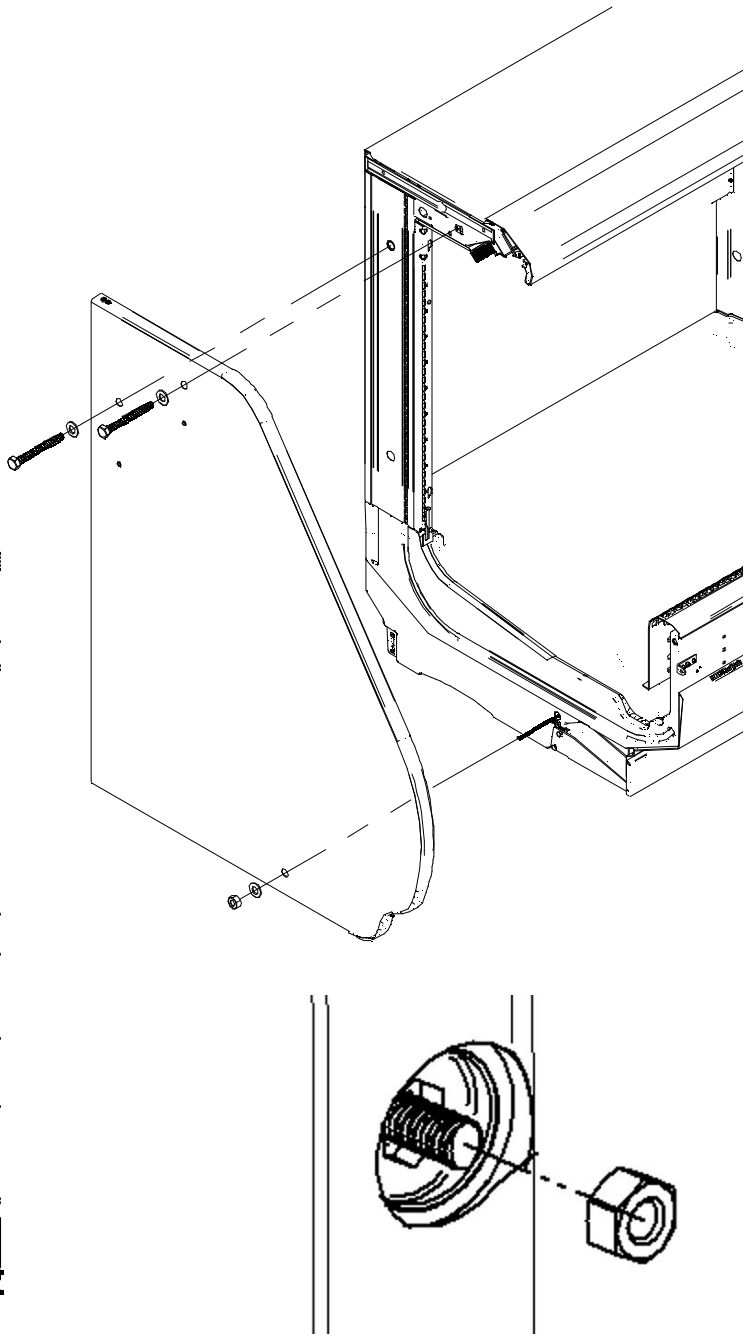
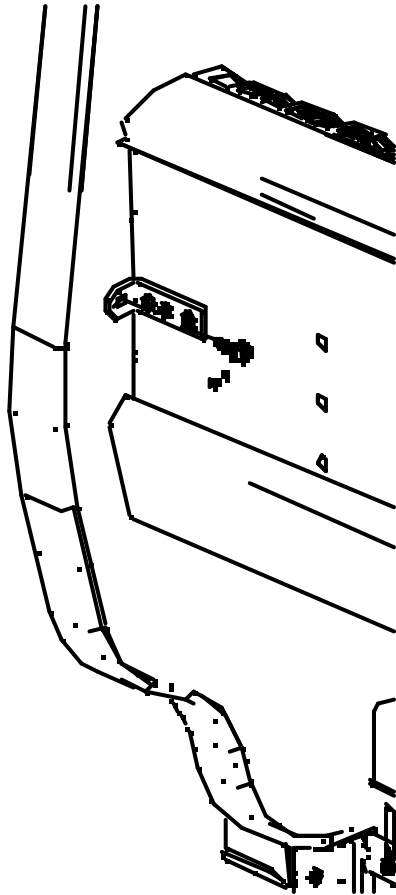
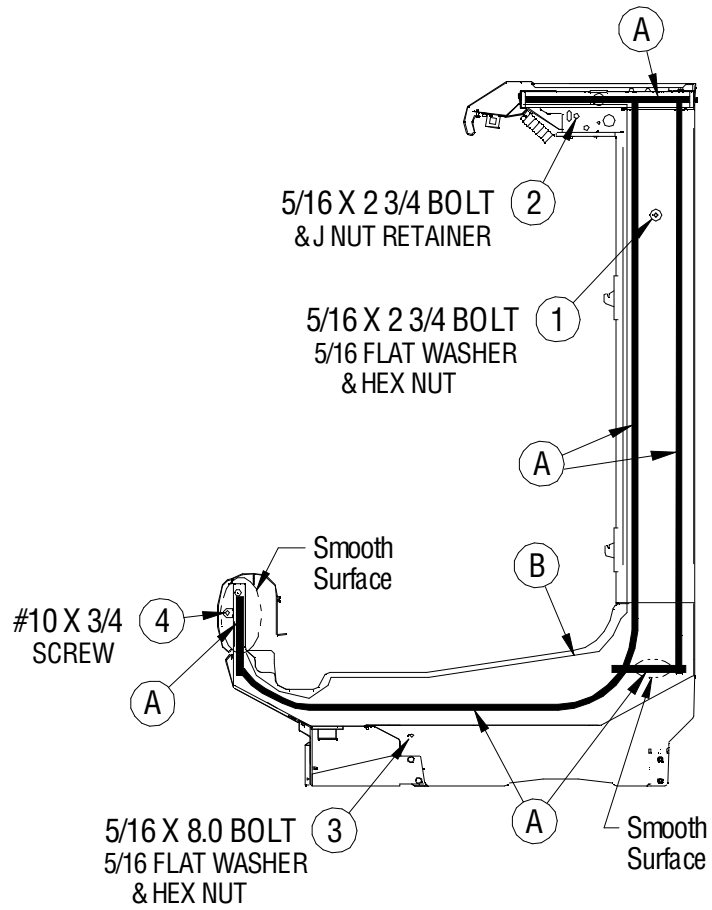

CONVERTIBLE DIFFERENT CASE PARTITIONS
CONTINUED

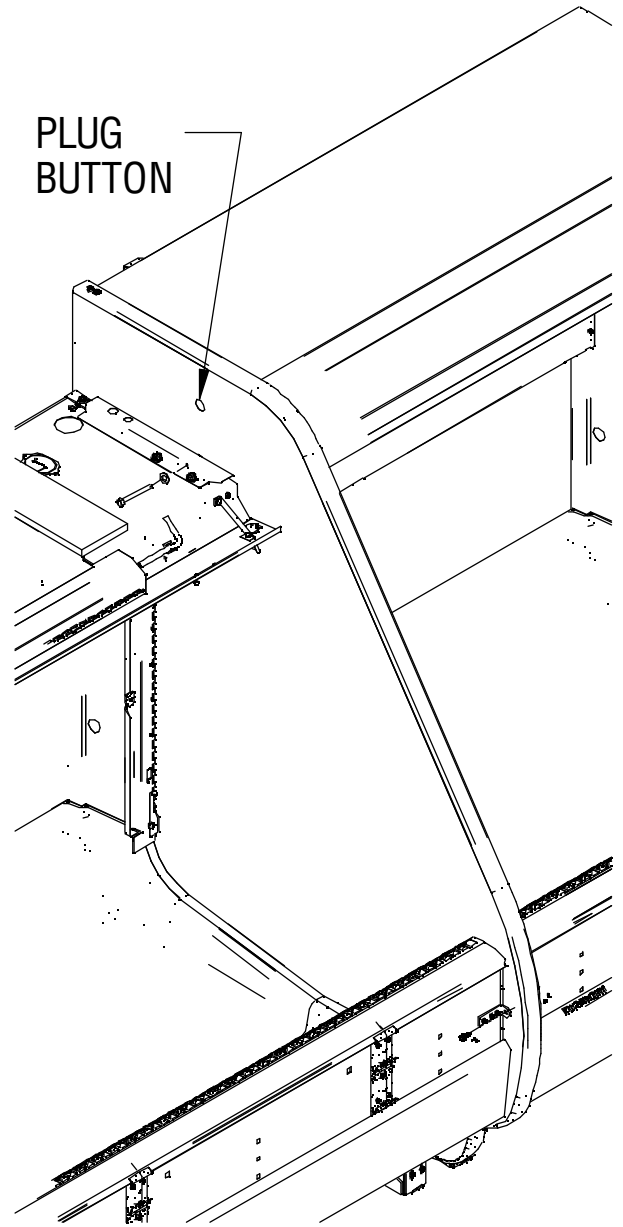
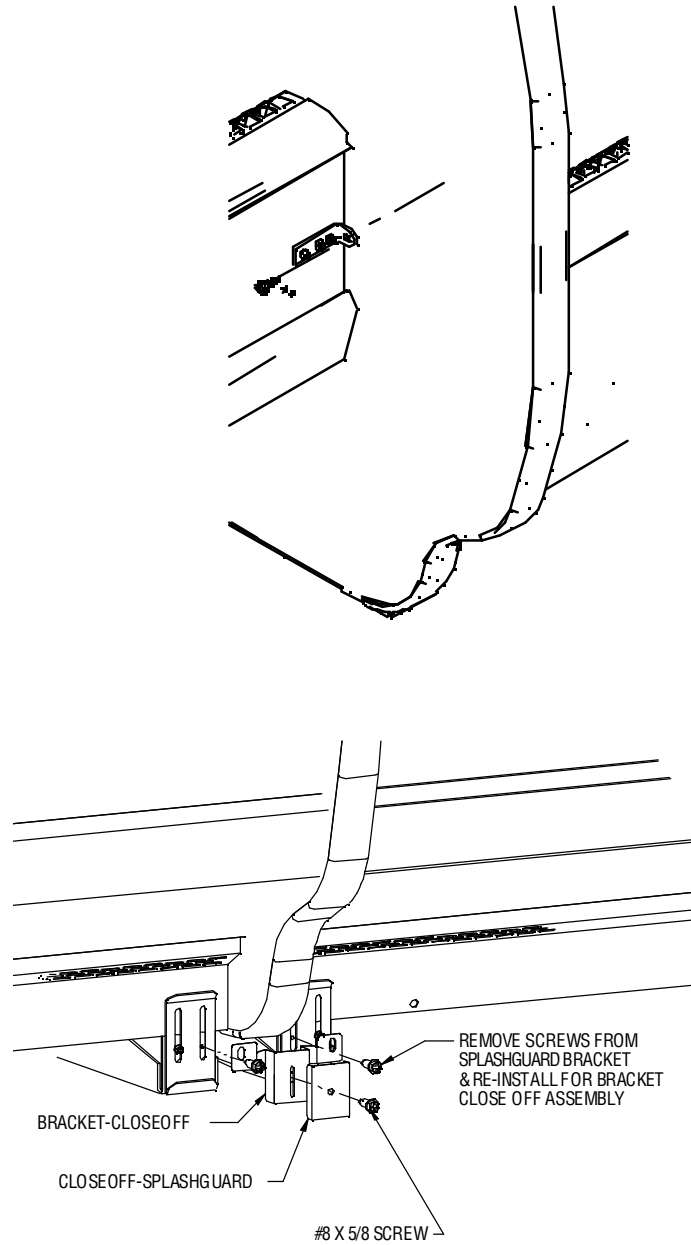
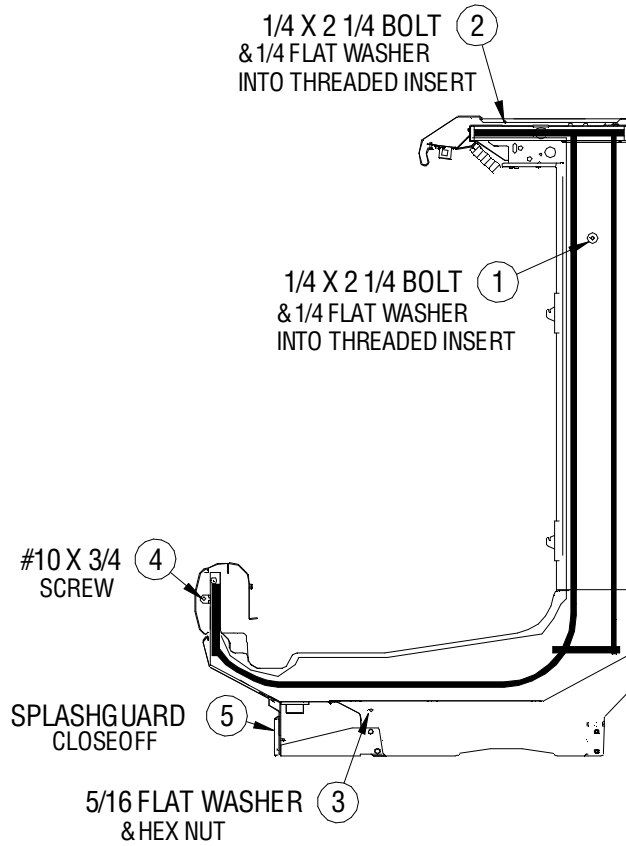

Refer to detail views.



ACRYLIC PARTITION HARDWARE

Description	Multi Deck Qty/Each	Convertible Qty/Each
PARTITION-ACRYLIC	1	1
BRACKET-CANOPY	1	1
BRACKET-RETURNAIRGRILL	N/A	1
SCREWS#8 x 5/8 HEX	3	4
SCREWMACHINE#8 x 1/2 PHILL	3	4
LOCKWASHER-#8 EXT TOOTH	3	4
NUT-#8 MACHINEHEX	3	4

Screw-Sheet Metal #8 x 5/8  

Screw-Machine #8 x 1/2 Phill  

Lockwasher-Ext Tooth #8  

Nut Machine Hex-#8  

Bracket-Canopy Multideck

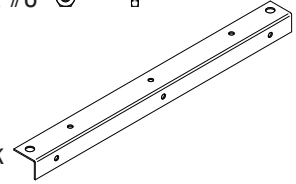

Bracket-Canopy Convertible

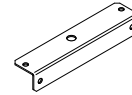

Bracket-Return Air Grill



Partition-Acrylic



ACRYLIC PARTITIONS - MULTIDECK

Refer to detail views.

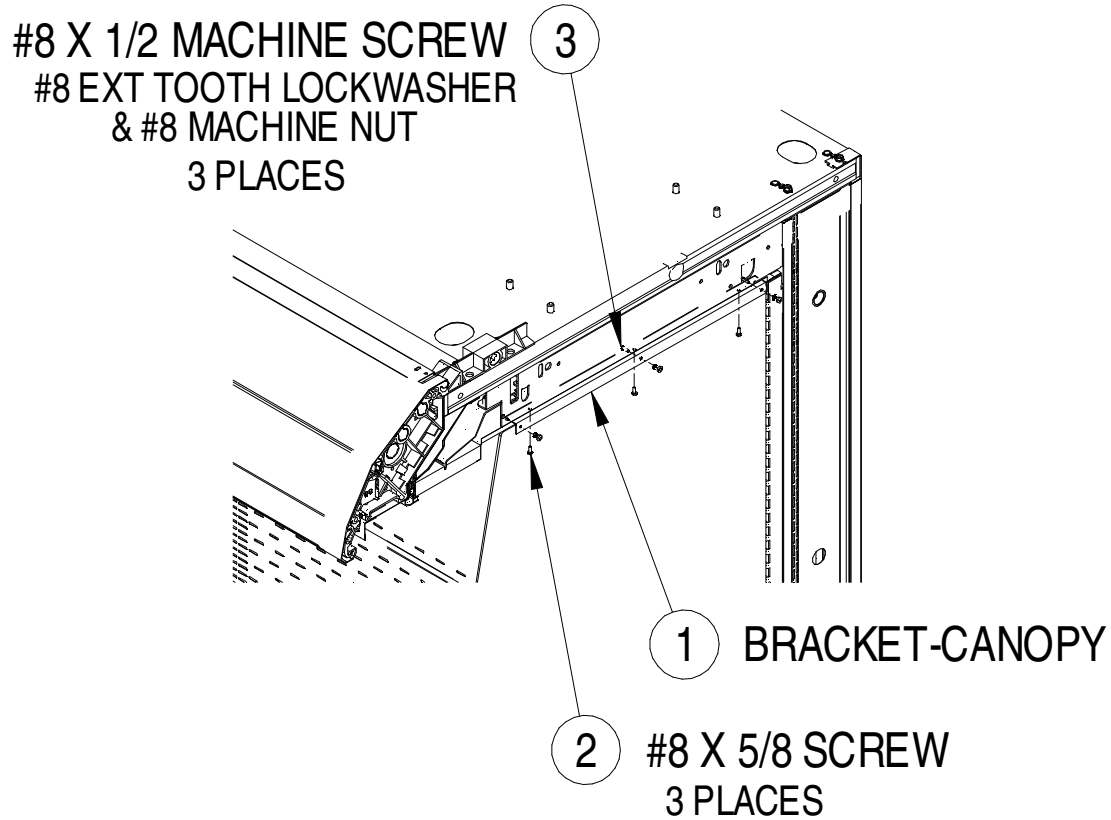

ACRYLIC PARTITION
TO BE MOUNTED
BETWEEN TWO
CASES ATTACH
BRACKET TO ONLY
ONE CASE

This technical drawing illustrates the installation of an acrylic partition between two cases. The partition is shown as a curved, perforated panel. The bracket-canopy assembly is attached to the top of one case, and the acrylic partition is mounted between the two cases. The drawing shows the partition being held in place by the bracket-canopy assembly.

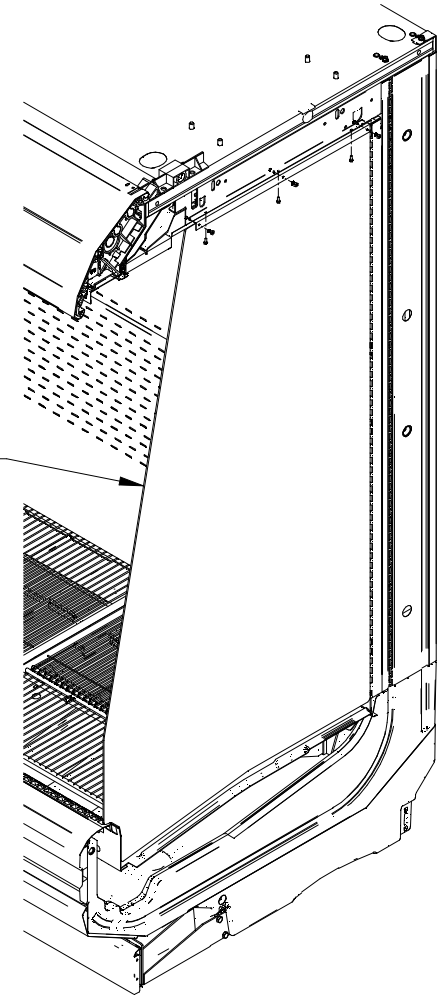

CONVERTIBLE
ACRYLIC PARTITIONS

Refer to detail views.

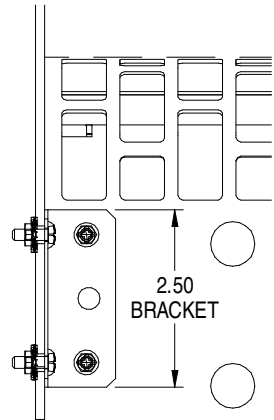

RETURN AIR GRILL VIEW
APPROXIMATE LOCATION
OF BRACKET

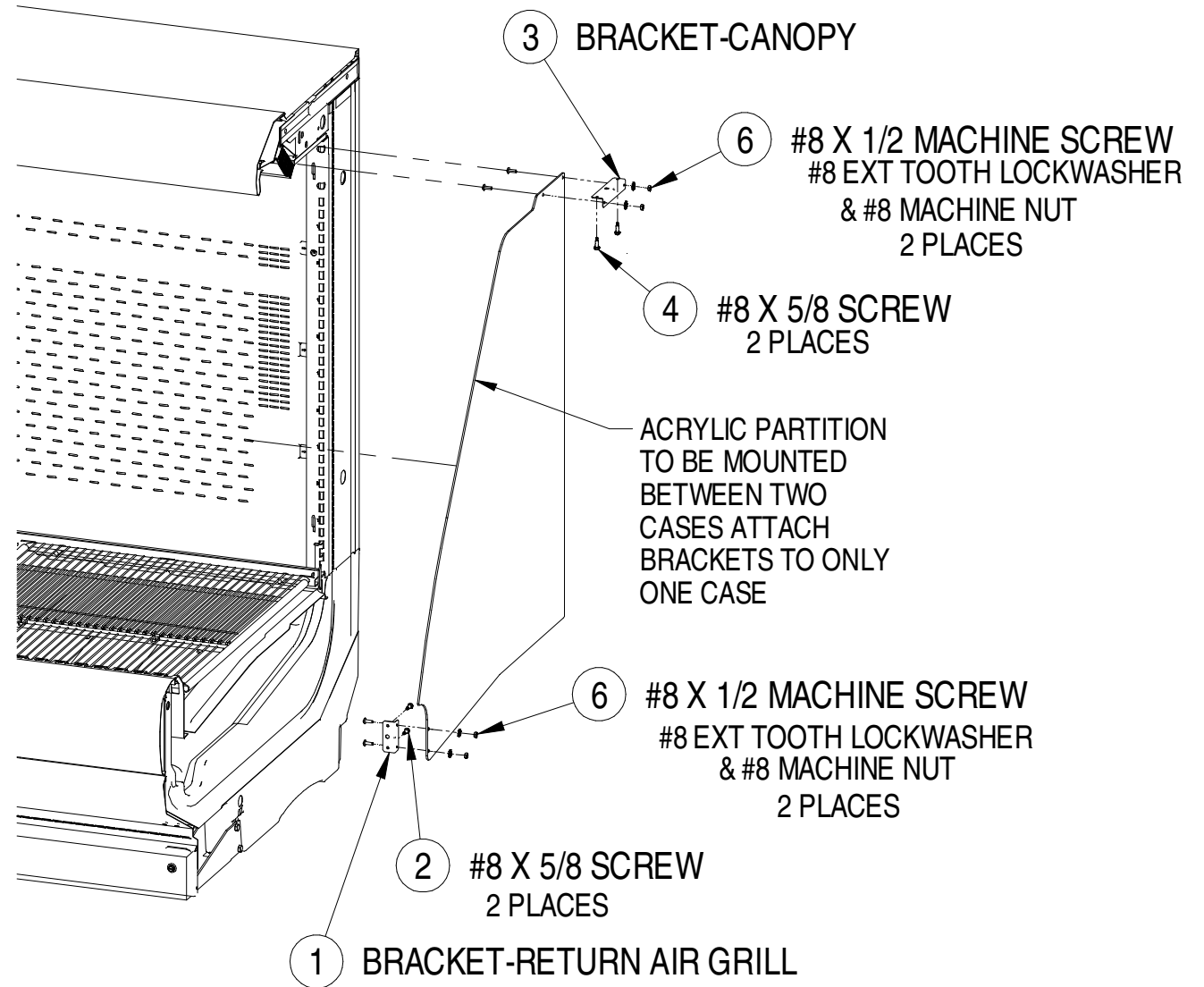

INSTALLING BUMPERS

1. Bumpers are packed out with the case and snap onto the bumper retainer. Gaskets are factory installed in the bumper retainers to provide support for the bumpers. Do not remove the gaskets.
2. Bumper joint inserts are provided with the case to disguise joints for a lineup of cases.
3. Start at the left end of the lineup. Install 3ft starter bumper first. Refer to bumper side view illustration to ensure the bumper is orientated correctly. Place top of bumper over bumper retainer, then snap bottom of bumper into place at bottom of retainer. Position internal joint trim between the starter bumper and full-length bumper.
4. Continue installing bumper(s) until the lineup is complete. The last piece of bumper will need to be cut so that it is flush with the right end cap. Use a fine tooth saw to cut the bumper vertically at a 90° angle.
5. Ensure joint trim is positioned behind bumper at all joints to close any gaps in the lineup. Remove protective film from bumper once installation is complete.

NOTE Bumpers come in two styles —
Ellipse and Faceted.

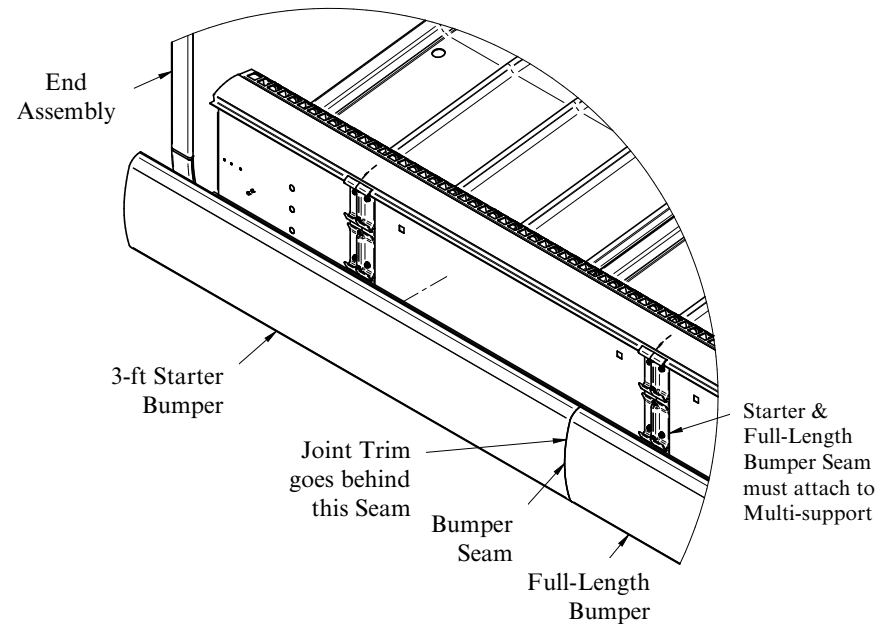
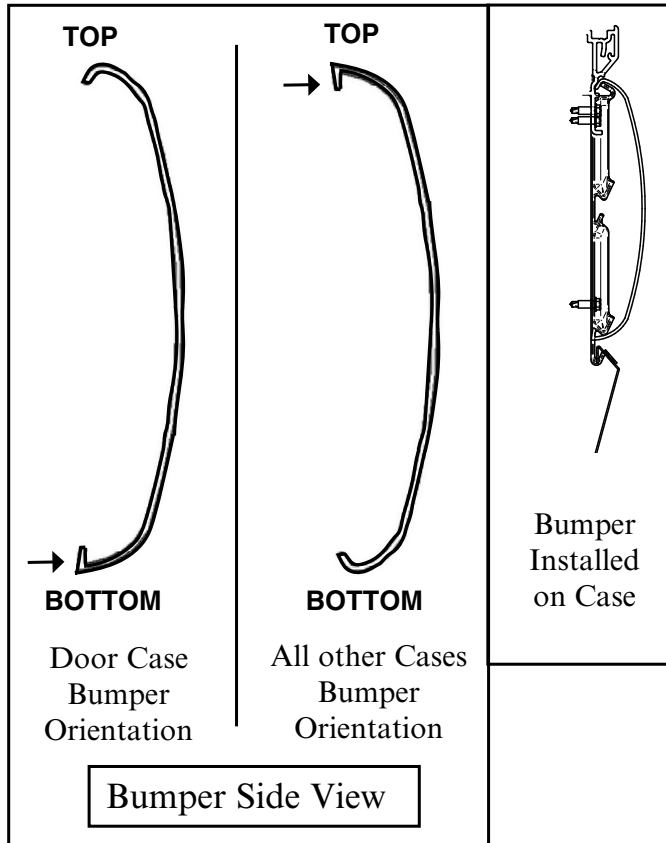
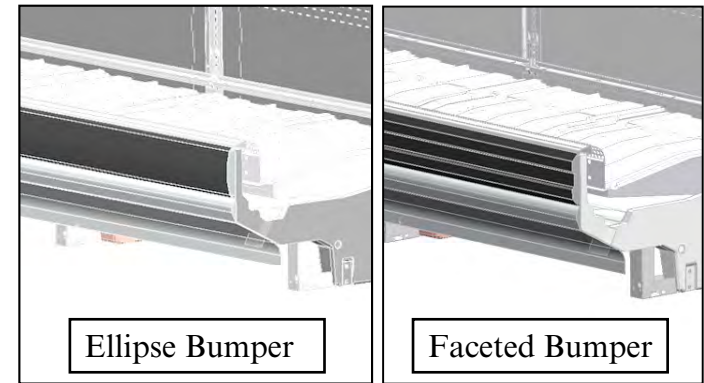

INSTALLING NIGHT BLINDS

STEP 1

Slide the lefthand night blind into bracket cutout.

NOTE  Left section of case always uses the front cutout. Alternate front to back for remaining sections.

STEP 2

Swing righthand side of night blind into slot on side of canopy support arm.

NOTE  Left section of case always uses the bottom slot. Alternate bottom to top for remaining sections.

STEP 3

Push/pull down on night blind slightly to slide pin past detent.

STEP 4

Check pin engagement to ensure at least 3/16" of pin is firmly in the slot.

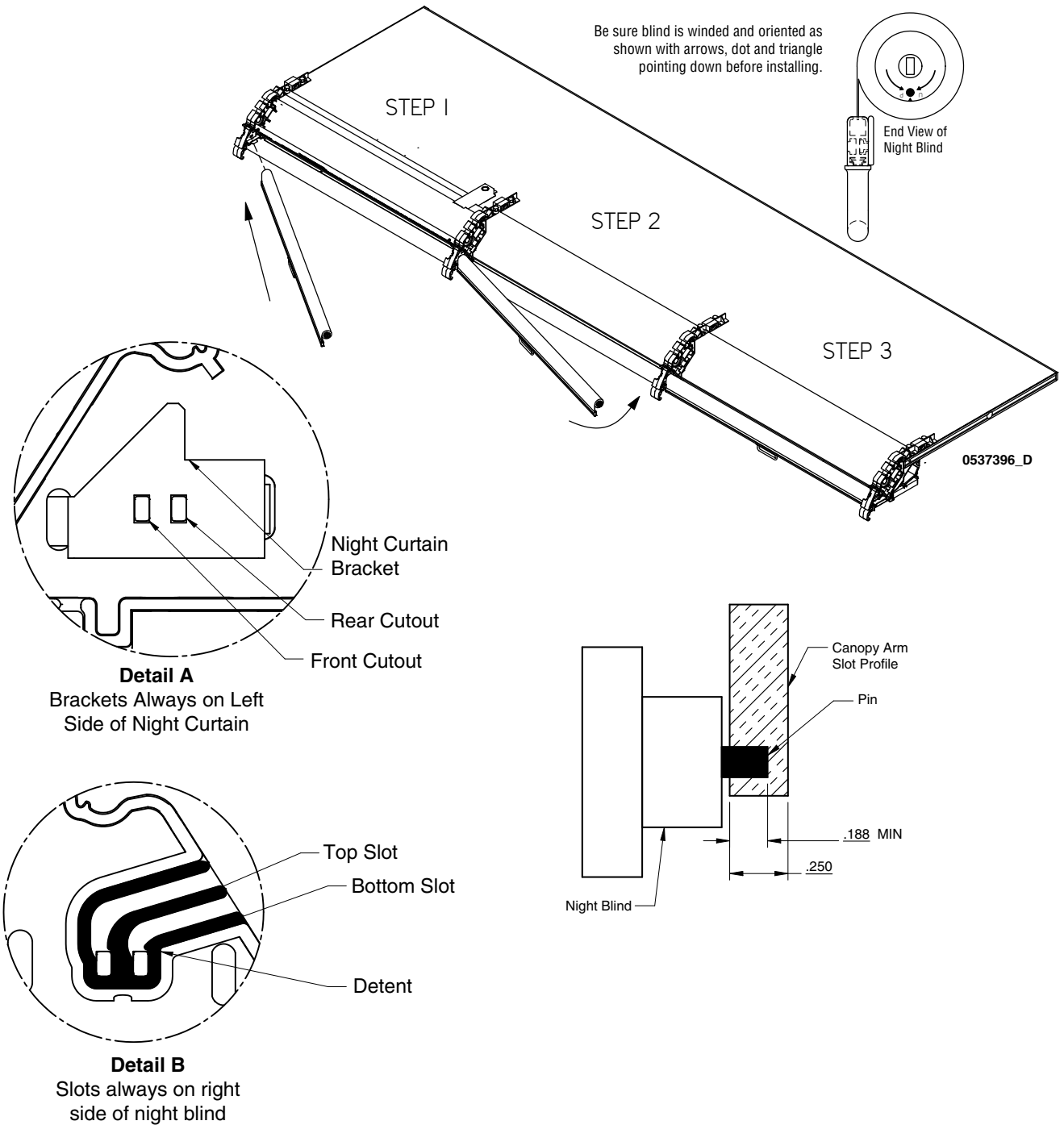

Be sure blind is wound and oriented as shown with arrows, dot and triangle pointing down before installing.

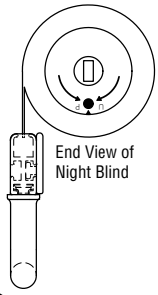

End View of Night Blind

0537396_D

Detail A
Brackets Always on Left Side of Night Curtain

Detail B
Slots always on right side of night blind

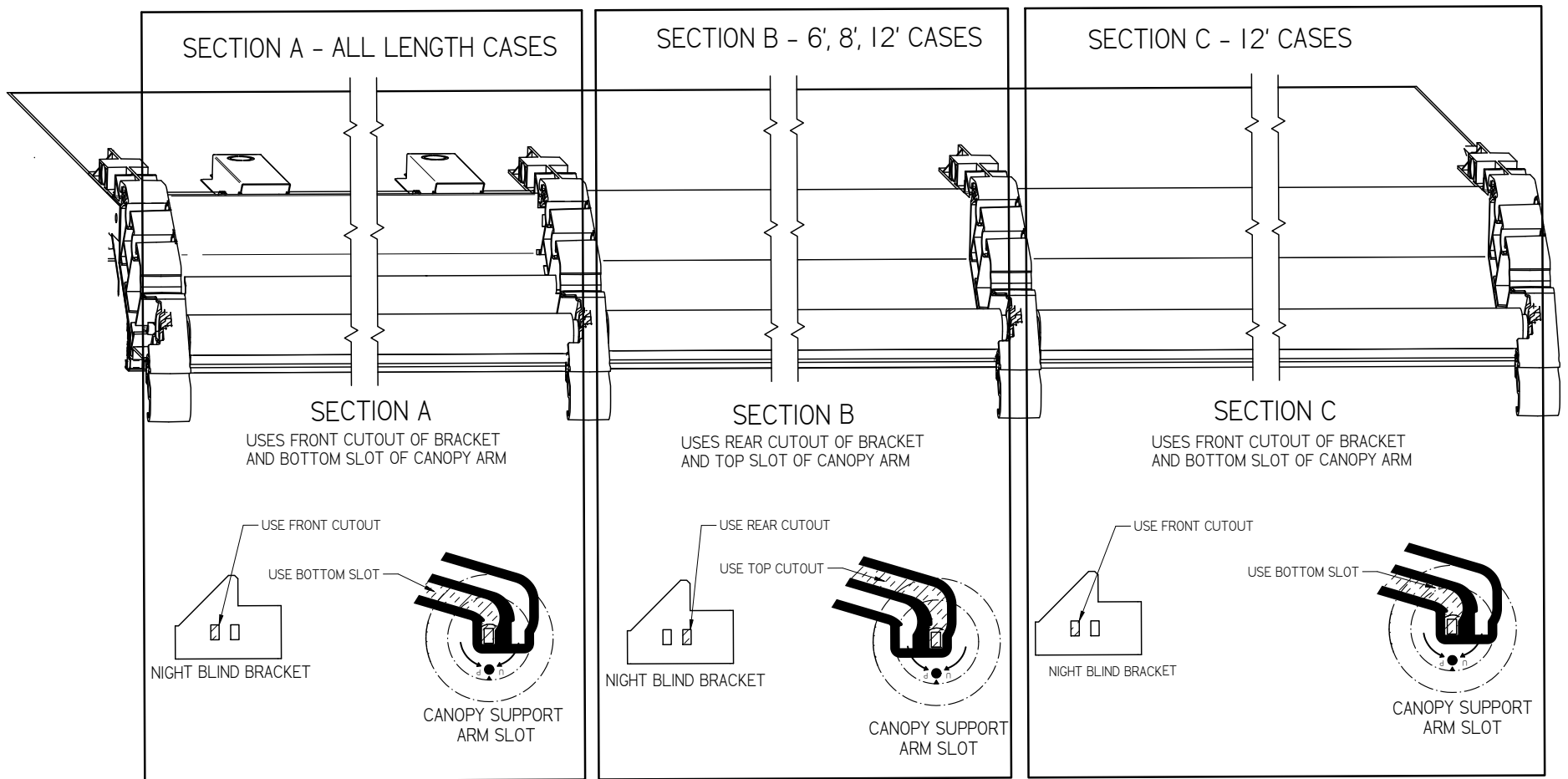

LOADING BLIND SPRING

Night blinds are delivered preloaded. However, if it is necessary to load night blind spring, use a wrench (part number [0477098](#)) to twist rectangular pin on right side of night blind. Twist clockwise 14 to 15 full revolutions.

NOTE  **Keep arrow / dot / up pointed up while winding. Keep pointed down when installed.**



Reference Mark (triangle or circle) must be oriented upward when winding and downward during installation.

Image showing wrench tightening night blind

Night Blind Handle

Twist wrench clockwise for 14 to 15 revolutions

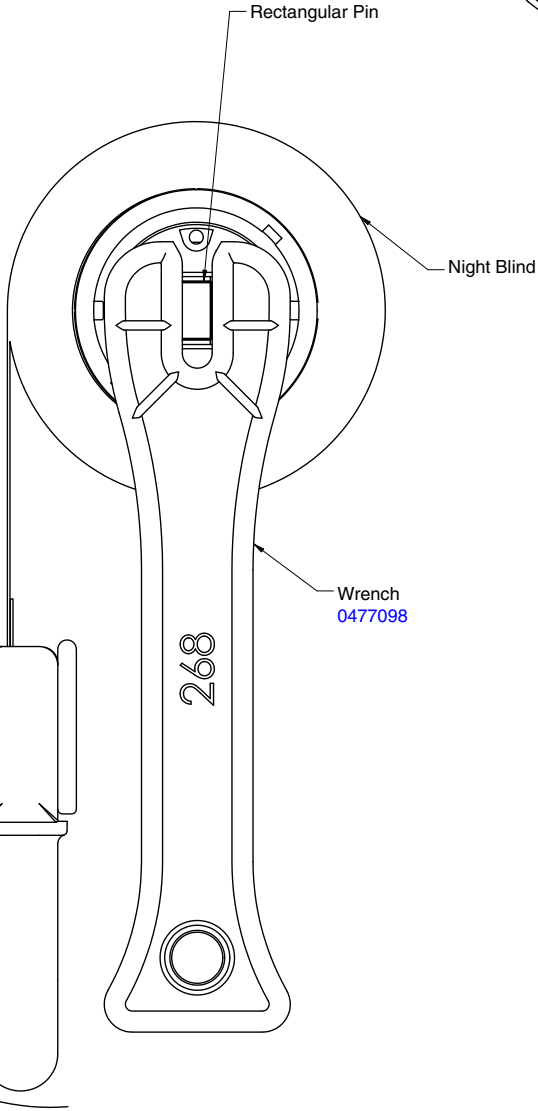

Rectangular Pin

Night Blind

Wrench 0477098

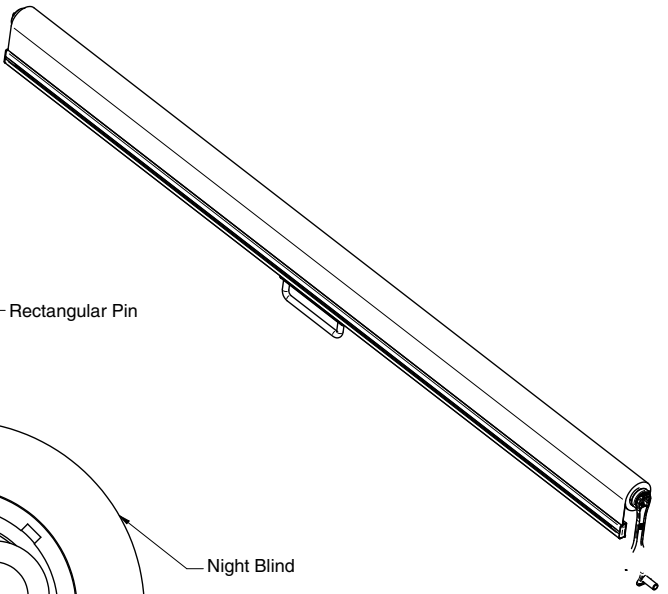

TROUBLESHOOTING NIGHT BLINDS

If night blind is not installed:

STEP 1

Only install brackets on the lefthand support arm and each center support arm.

STEP 2

On the righthand side of each arm, insert front tab of bracket into the front slot, then snap into the rear slot.

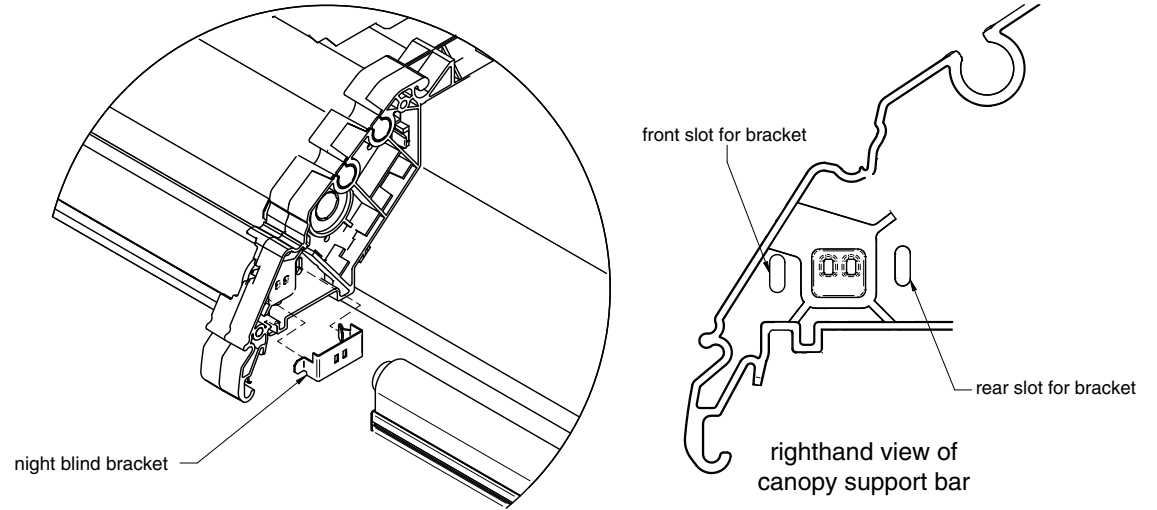

If pin is too short or rounding out canopy arm:

STEP 1

Remove night curtain from case.

STEP 2

Use pliers to pull metal pin out to desired length.

STEP 3

Replace night curtain into canopy

NOTE  **Keep pointed down when installed.**

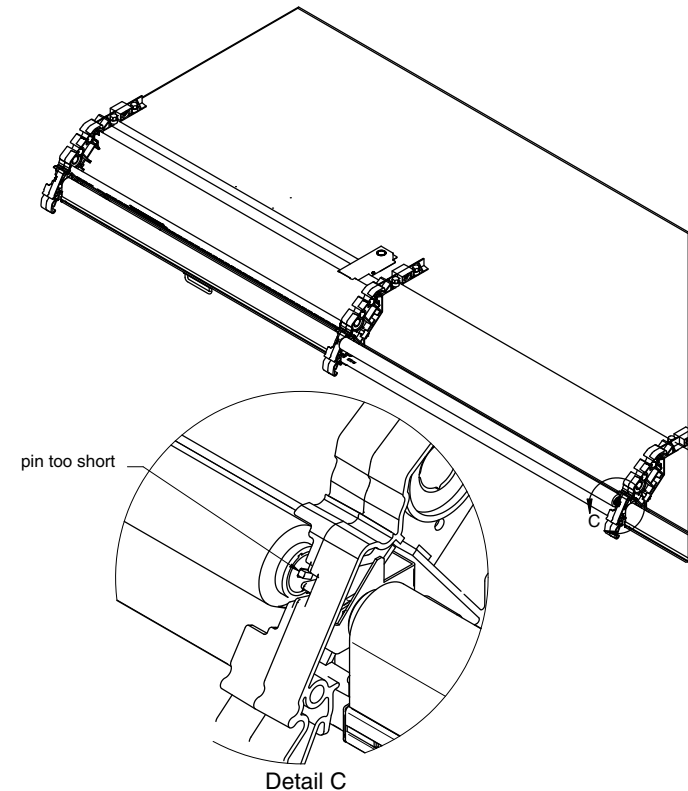

REFRIGERATION / ELECTRICAL

REFRIGERANT

The correct type of refrigerant will be stamped on each merchandiser's serial plate. The merchandiser refrigeration piping is leak tested, factory sealed and pressurized. Before making refrigeration hookups, depress the universal line valve to ensure that coils have maintained pressure during shipment. When using high glide refrigerants (e.g., R-407A, R-448A), if superheat needs to be adjusted, use the evaporator pressure and subtract the dew point from the coil outlet refrigerant temperature to measure the superheat level.

The triple evacuation method should be used to achieve a leak-free, dry system. For the first evacuation, the system should be pulled down to 1,000 microns. The second evacuation should be pulled to 500 microns. The final evacuation should be pulled down to at least 300 microns. A dry, leak-free system is when the system holds a vacuum of 300 microns for 24 hours with the vacuum pump de-energized and valved off. Between each evacuation, break the vacuum with dry nitrogen.

When connecting hoses between the refrigeration system, manifold gauges, and refrigerant cylinder, ensure that the connections are secure and there are no potential sources of ignition nearby. Ensure that contamination of different refrigerants does not occur when using charging equipment.

Use dedicated hoses to service the type of refrigeration system being serviced (e.g., R-454C equipment for an R-454C system). Hoses or lines should be as short as possible to minimize the amount of refrigerant contained in them.

Ensure that the refrigeration system is properly grounded prior to charging the system with refrigerant, to avoid the potential for static build-up. In addition to conventional charging procedures, the following requirements shall be followed:

- a. Ensure that contamination of different refrigerants does not occur when using charging equipment. Hoses or lines shall be as short as possible to minimize the amount of refrigerant contained in them.
- b. Cylinders shall be kept in an appropriate position according to the instructions.

- c. Ensure that the REFRIGERATING SYSTEM is earthed prior to charging the system with refrigerant.
- d. Label the system when charging is complete (if not already).
- e. Extreme care shall be taken not to overfill the REFRIGERATING SYSTEM.

Prior to recharging the system, it shall be pressure-tested with the appropriate purging gas. The system shall be leak-tested on completion of charging but prior to commissioning. A follow up leak test shall be carried out prior to leaving the site.

Extreme care must be taken not to over fill the refrigeration system. After charging, carefully disconnect the hoses, attempting to minimize the quantity of refrigerant released. Further leak check the service ports, hoses, refrigerant tanks.

WARNING

- » Refrigeration lines are under pressure. Depressurize and recover refrigerant before attempting any connection or repair. Refrigerant vapor is hazardous to your health and can cause death. Avoid breathing refrigerant and lubrication vapor or mist. Exposure may irritate eyes, nose and throat. If accidental system discharge occurs, ventilate work area before resuming service.
- » Always wear safety goggles and protective gloves when working with refrigerants. Contact with refrigerant may cause injury. Disconnect hoses with extreme caution! All hoses may contain liquid refrigerant under pressure.
- » Be sure that any room where you are working is thoroughly ventilated, especially if a leak is suspected.
- » Read all safety information regarding the safe handling of refrigerant and refrigerant oil, including the Material Safety Data Sheet. MSDS sheets can be obtained from your refrigerant supplier.

PIPING INSTALLATION REQUIREMENTS

- Installation shall include protection from physical damage in operation and service and be in compliance with national and local codes and standards, such as ANSI/ASHRAE 15, IAPMO Uniform Mechanical Code, ICC International Mechanical Code, or CSA B52. All field joints shall be accessible for inspection prior to being covered or enclosed.
- The installation of pipework shall be kept to a minimum.
- A brazed, welded, or mechanical connection shall be made before opening the valves to permit refrigerant to flow between the refrigerating system parts.
- Mechanical connectors used indoors shall comply with ISO 14903 or UL 207 or CSA C22.2 No. 140.3. When mechanical connectors are reused indoors, sealing parts shall be renewed. When flared joints are reused indoors, the flare part shall be refabricated.
- Refrigerant tubing shall be protected or enclosed to avoid damage. Flexible refrigerant connectors (such as connecting lines between the indoor and outdoor unit) that might be displaced during normal operation shall be protected against mechanical damage.
- Mechanical connections shall be accessible for maintenance purposes.
- Provision shall be made for expansion and contraction of long runs of piping.
- Protection devices, piping, and fittings shall be protected as far as possible against adverse environmental effects, for example, the danger of water collecting and freezing in relief pipes or the accumulation of dirt and debris.
- Piping in refrigeration systems shall be so designed and installed to minimize the likelihood of hydraulic shock damaging the system.
- Flexible pipe elements shall be protected against mechanical damage, excessive stress by torsion, or other forces, and they should be checked for mechanical damage annually.
- Precautions shall be taken to avoid excessive vibration or pulsation to the refrigerant piping.
- After completion of field piping for split systems, the field pipework shall be pressure tested with an inert gas and then vacuum tested prior to refrigerant charging, according to the following requirements as detailed by UL safety standard. Pressures may come from unit data plate or from customer specification.
 1. The minimum test pressure for the low side of the system shall be the low side design pressure and the minimum test pressure for the high side of the system shall be the high side design pressure, unless the high side of the system cannot be isolated from the low side of the system in which case the entire system shall be pressure tested to the low side design pressure.
 2. The test pressure after removal of the pressure source shall be maintained for at least 1 hour with no decrease of pressure indicated by the test gauge, with test gauge resolution not exceeding 5% of the test pressure.
 3. During the evacuation test, after achieving a vacuum level specified in the manual or less, the refrigeration system shall be isolated from the vacuum pump and the pressure shall not rise above 1500 microns within 10 min.
- Field-made refrigerant joints indoors shall be tightness tested according to applicable codes and requirements.
- Equipment piping in the occupied space shall be installed in such a way to protect against accidental damage in operation and service.
- Any solenoid valves and/or safety shut-off valves shall be correctly positioned in the piping to avoid hydraulic shock or pressure.
- Insulation shall be suitable for use with the material being insulated.
- The indoor equipment and pipes shall be securely mounted and guarded such that accidental rupture of equipment cannot occur from such events as moving furniture or reconstruction activities.

REFRIGERANT PIPING

Standard Case Connection Location

The refrigerant line connections are at the right end of the merchandiser (as viewed from the front) beneath the display pans. The installer must saw a hole to exit the case. After connections have been made, thoroughly seal this outlet. Seal both the inside and the outside.

It is recommended to use an expanding polyurethane foam insulation. Cover foam with silicone to prevent water from entering foam.

Refrigerant lines must not interfere with the drain covers. Drain covers must be removed to provide access for cleaning.

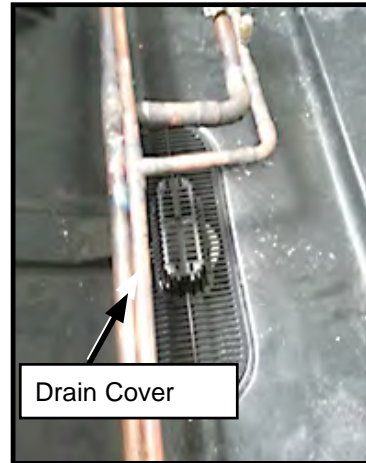
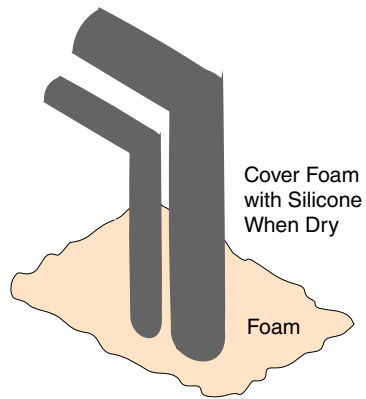

⚠️ WARNING

- » **Hussmann does not recommend using spray hoses or misting systems due to risk of serious injury or death from electrical shock.**
- » **Do not use spray hoses or misting systems on cases with shelf or rail lighting.**

BACK WALL PIPING PENETRATIONS

Cases that are to be piped from the back have a factory installed $\frac{1}{4}$ pilot hole in the exterior liner. Use the pilot hole to locate the hole saw to drill out a hole $2\frac{1}{2}$ " diameter hole to run the coil piping.

After connections have been made, thoroughly seal this outlet. Seal both the inside and the outside.

It is recommended to use an expanding polyurethane foam insulation. Cover foam with silicone to prevent water from entering foam.

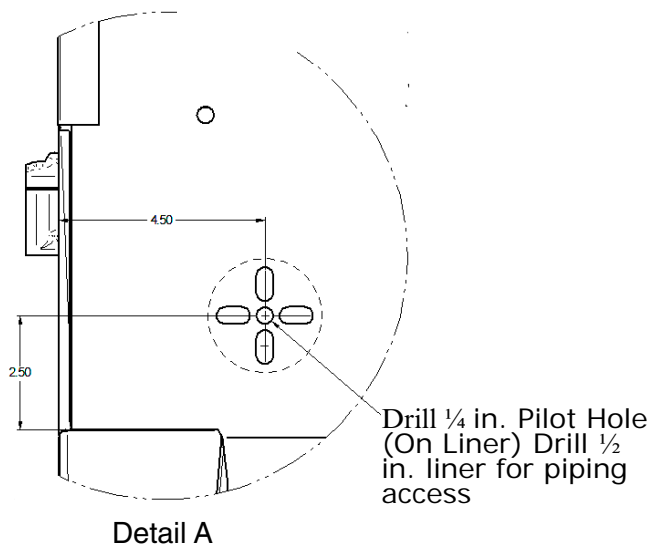

CAUTION

- » When brazing pipes be sure to use the insulation blanket shipped with the merchandiser to prevent damage to the foam bottom.

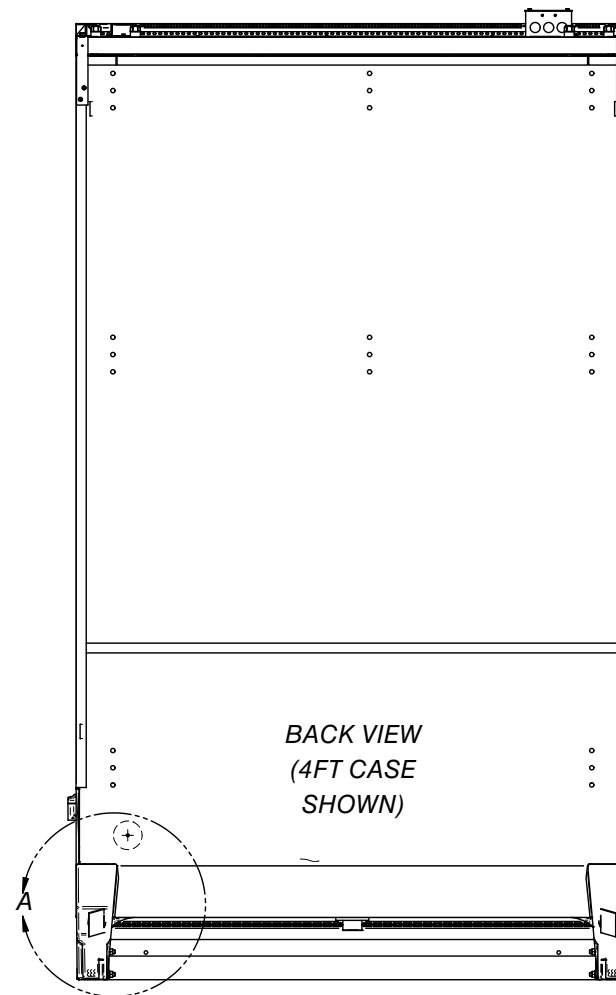

NARROW AND WEDGE CASE CONNECTION USE SHROUD

A shroud should be used to seal pipe penetrations in the bottom liner for narrow Insight cases as well as wedge cases. Saw a hole through the bottom liner that is large enough to fit the refrigerant piping.

Place the refrigeration shroud over refrigeration piping so that when the shroud is rotated into place, it will be in the upright position.

Use the supplied refrigeration brazing blanket to avoid burning the liner. Be careful not to burn, scorch or over-heat the shroud when making connections

Attach the shroud to the liner using 8 supplied screws. Apply a continuous bead of silicone sealant around the bottom of the shroud after all connections are made and insulation has been applied to the piping. Seal the outlet thoroughly. Seal both the inside and outside. Hussmann recommends using expanding polyurethane foam insulation. Cover foam with silicone to ensure seal around insulation and to prevent deterioration of foam.

NOTE:

Wedge cases get sheet metal screws, narrow cases use plastic screws.

Multiplexing

Piping of merchandisers operating on the same refrigeration system may be run from merchandiser to case. Do not run refrigerant lines through merchandisers that are not on the same refrigeration system branch as this may result in poor refrigeration control and compressor failure.

Interconnecting piping inside the case must be located as shown below to allow room for lifting the hinged fan plenums and for clearance beneath the display pans. Alternately, the interconnecting piping may be run outside the case.

Line Sizing

Refrigerant lines should be sized as shown on the refrigeration legend that is furnished for the store or according to ASHRAE guidelines. Refer to the information on the next page for branch line piping of Hussmann Equipment.

Oil Traps

P-traps (oil traps) must be installed at the base of all suction line vertical risers.

Pressure Drop

Pressure drop can rob the system of capacity. To keep the pressure drop to a minimum, keep the refrigerant line run as short as possible using a minimum number of elbows. Where elbows are required, use long radius elbows only.

INSULATION

Additional insulation for the balance of the liquid and suction lines is recommended wherever condensation is objectionable or lines are exposed to ambient conditions.

SUCTION LINE

- Pitch in direction of flow.
- May be reduced by one size at one third of merchandiser run load and again after the second third. Do not reduce below the merchandiser suction line size.
- Merchandiser suction lines should enter at the top of the branch line.

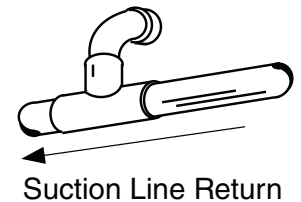

LIQUID LINE

May be reduced by one size after one half the merchandiser run load. Do not reduce below the merchandiser liquid line connection size.

Take-offs to merchandiser liquid lines should exit the bottom of the branch liquid line. Provide an expansion loop for each evaporator take-off (minimum 3 inches [76 mm] loop).

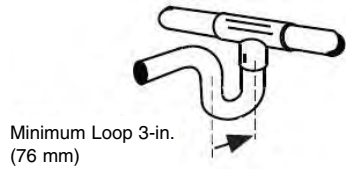

Liquid Line Take Off

REFRIGERATION THERMOSTAT

Insight models do not use a defrost termination thermostat and are time terminated only.

DEFROST SEQUENCES

Insight merchandisers require defrost cycles for proper operation. Refer to the data sheets for application data. The Time Clock initiates defrost. The evaporator fans continue to circulate air across the evaporator coil, melting any frost build-up. If temperature termination is required, an applicable defrost sensor must be installed on the case.

Offtime Defrost

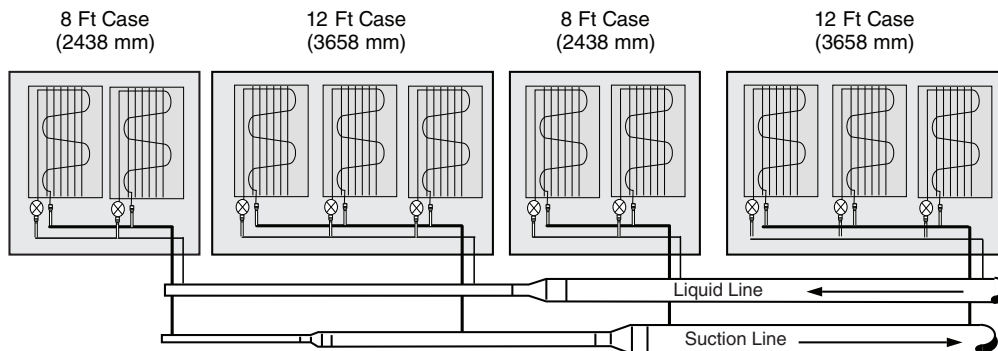

MERCHANDISER ELECTRICAL DATA

Technical data sheets are also shipped with the case. The data sheets provide merchandiser electrical data, electrical schematics, parts lists and performance data. Refer to the technical data sheets and merchandiser serial plate for electrical information.

ELECTRICAL CONNECTIONS

All wiring must be in compliance with NEC and local codes. All electrical connections are to be made in the electrical raceway or Handy Box.

FIELD WIRING

Field wiring must be sized for component amperes stamped on the serial plate. Actual ampere draw may be less than specified.

Field wiring from the refrigeration control panel to the merchandisers is required for defrost termination thermostats and for optional refrigeration thermostats. When multiple merchandisers are on the same defrost circuit, the defrost termination thermostats are wired in series. Field wiring from the refrigeration control panel to the merchandisers is required for defrost termination thermostats and for optional refrigeration thermostats. When multiple merchandisers are on the same defrost circuit, the defrost termination thermostats are wired in series.

IDENTIFICATION OF FIELD WIRING

ALWAYS CHECK THE SERIAL PLATE FOR COMPONENT AMPERES.

Leads for all electrical circuits are identified by colored plastic bands. These bands correspond to the color code sticker (shown below) located inside the merchandiser's wireway cover.

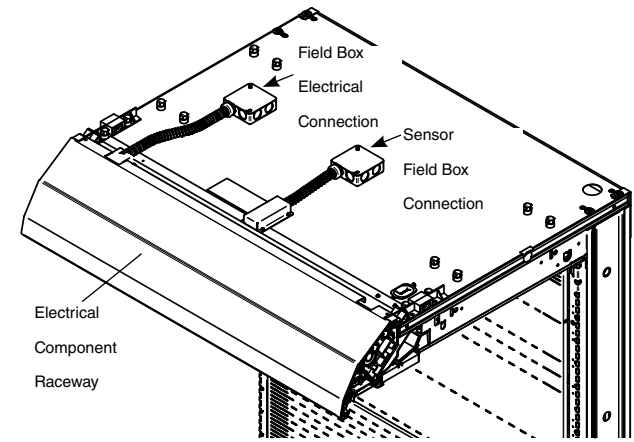

SENSOR LOCATION

Discharge air sensor is located in the case canopy by the honeycomb. An electrical box is shown at right for field installation of the sensor. (Field box may not be present if a sensor was not originally factory installed.)

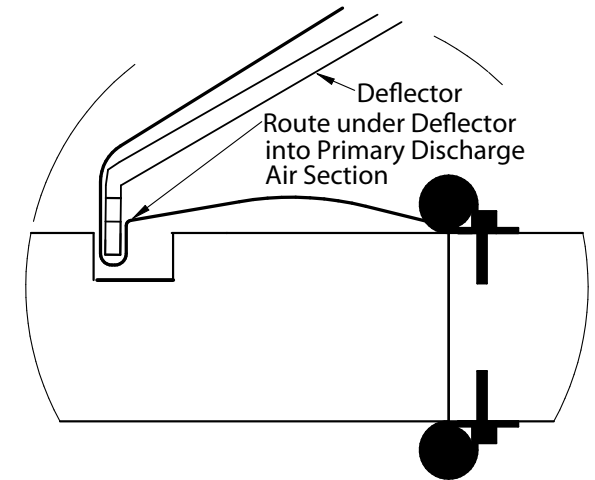
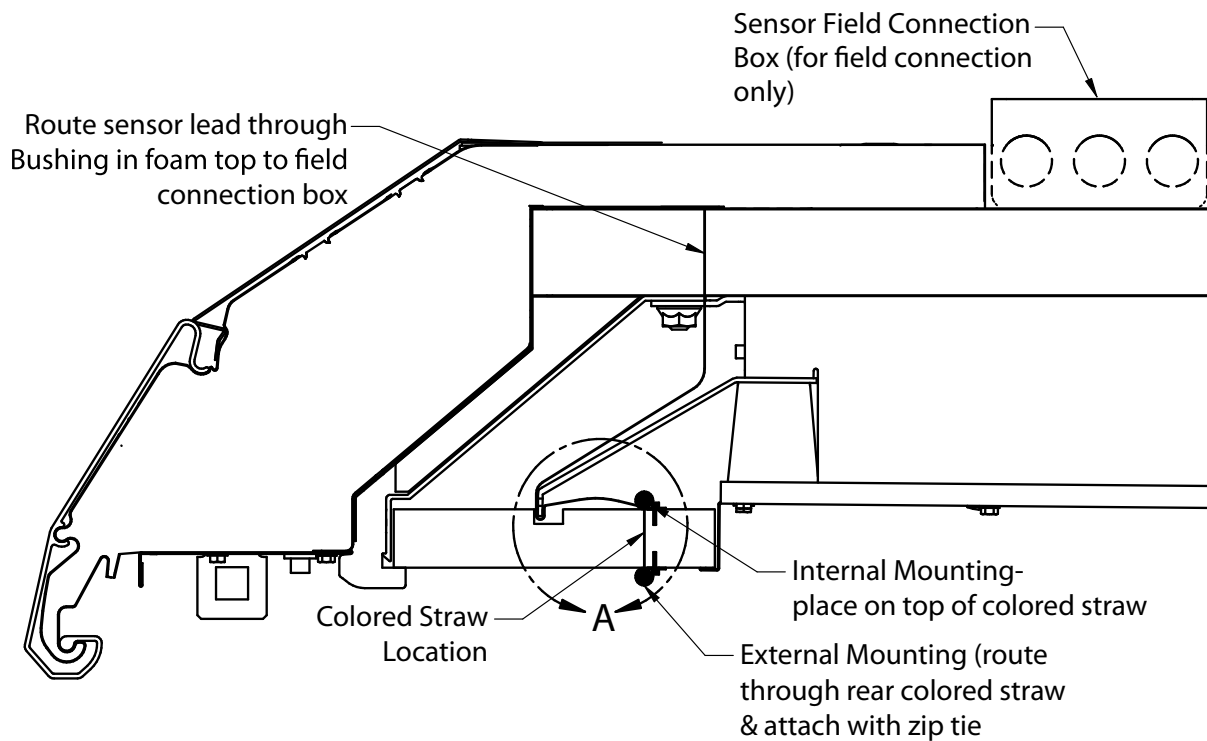

ELECTRICAL ACCESS FOR SIGN-READY & FLAT-FRONT FASCIAS

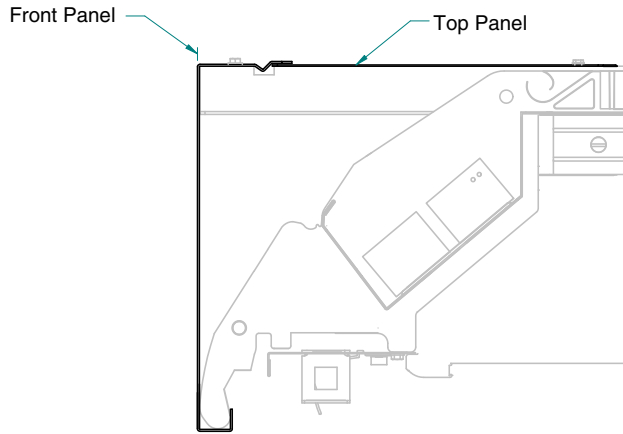

WIRING COLOR CODE

Leads for all electrical circuits are identified by a colored plastic band: neutral wire for each circuit has either White insulation or a White plastic sleeve in addition to the color band.

PINK.....	REFRIG. THERMOSTAT LOW TEMP.	ORANGE OR	
LIGHT BLUE...	REFRIG. THERMOSTAT NORM TEMP.	TAN.....	LIGHTS
DARK BLUE....	DEFROST TERM. THERMOSTAT	MAROON	RECEPTACLES
PURPLE.....	CONDENSATE HEATERS	YELLOW.....	DEFROST HEATERS 120V
BROWN.....	FAN MOTORS	RED	DEFROST HEATERS 208V
GREEN*.....	GROUND *EITHER COLORED SLEEVE OR COLORED INSULATION		

**ELECTRICIAN NOTE: Use copper conductor wire only.
MERCHANTISER MUST BE GROUNDED**

THESE ARE MARKER COLORS, WIRES MAY VARY.

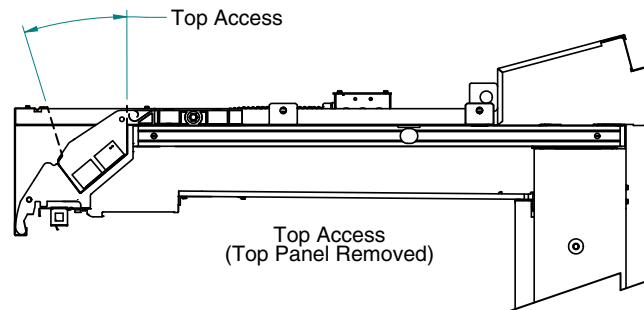
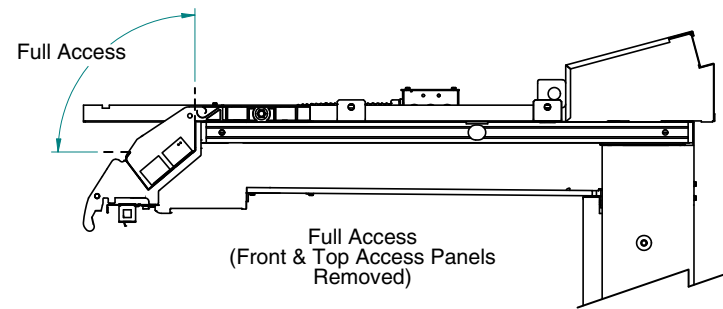
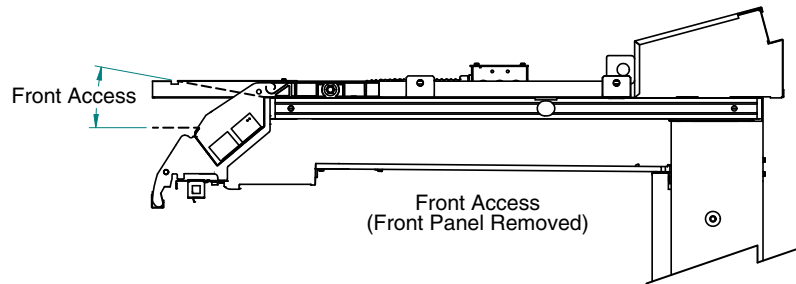

DRIP PIPING / FIT & FINISH / SPLASHGUARDS

WASTE OUTLET AND WATER SEAL

Insight merchandisers have one waste outlet located in the front center of the bottom or right-hand side for 8 ft cases. Water seals are field installed with waste outlet to prevent air leakage and insect entrance into the case. Tees and clean-outs are supplied for each case.

A hat-shaped strainer is also shipped with the merchandiser. Place strainer over the waste outlet as shown below.

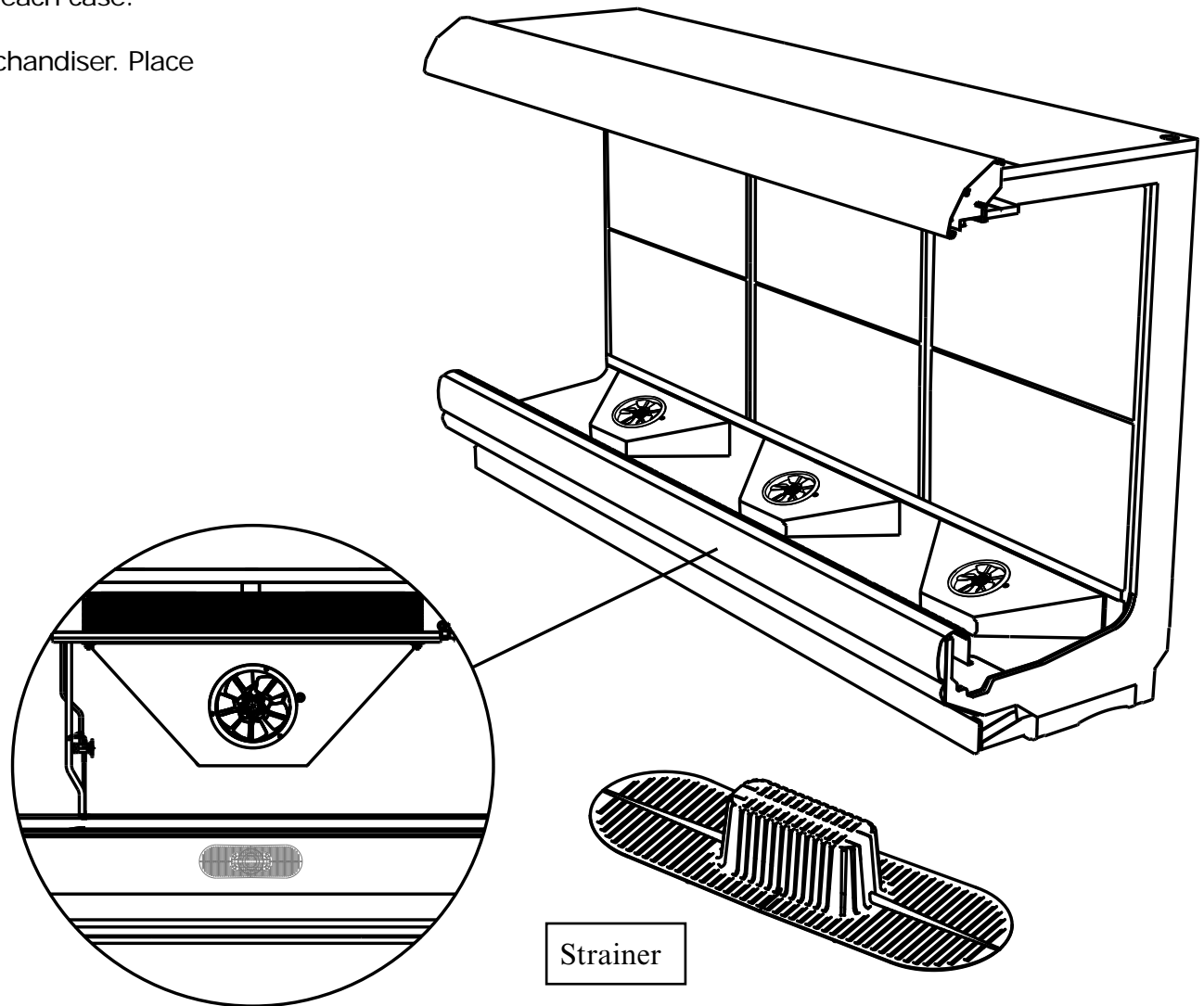
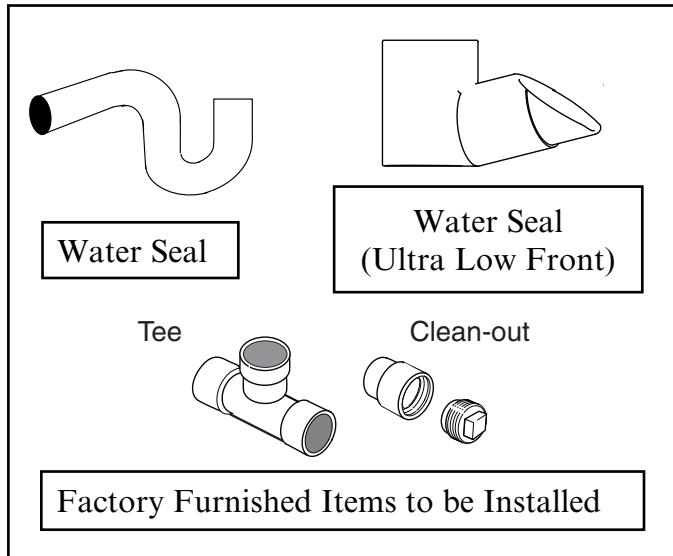

INSTALLING DRIP PIPING

Poorly or improperly installed drip pipes can seriously interfere with the merchandiser's operation and result in costly maintenance and product losses.

Optional drip pipe arrangements are shown on the next page. It is the installing contractor's responsibility to consult local agencies for local code requirements. Assemble the components using field-supplied PVC primer and glue according to the manufacturers direction.

Please follow the recommendations listed below when installing drip pipes to ensure proper installation.

1. When connecting drip piping, the "water seal" must be used as part of the drip piping to prevent air leakage or insect entrance. Never use two water seals in series in any one drip pipe. Double water seals in series will cause an air lock and prevent draining.
2. Pitch the drip piping in the direction of flow. There should be a minimum pitch of $\frac{1}{4}$ " per ft (20 mm per 1 m).

3. Avoid long runs of drip piping. Long runs make it impossible to provide the pitch necessary for good drainage.
4. All connections must be watertight and sealed with the appropriate PVC or ABS cement.
5. Ensure that drip piping is supported to relieve any stress on drip pipe connectors and drain hub. Drip piping MUST be supported no more than 24 in. from drain hub tee.
6. Provide a suitable air break between flood rim of the floor drain and outlet of drip pipe. To meet code on low base merchandisers, it may be necessary to install a field-supplied drip pipe reducer. An alternative is to cut the last section of drip pipe at an angle.
7. Prevent drip pipes from freezing: Do not install drip pipes in contact with uninsulated suction lines. Suction lines should be insulated with a nonabsorbent insulation material. Where drip pipes are located in dead air spaces, such as between merchandisers or between a merchandiser and a store wall, provide means to prevent freezing.



Drip Piping Example for Standard Case Height (Not for Ultra Low Front Cases)

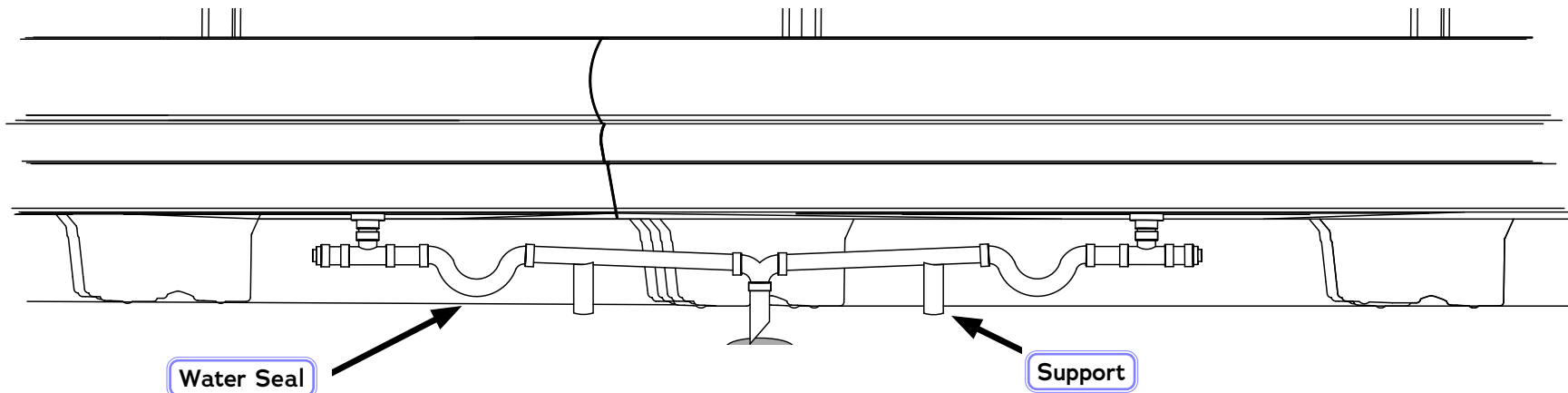

Never use drip piping smaller than the nominal diameter of the pipe or water seal supplied with the merchandiser.



It is the installing contractor's responsibility to consult local agencies for local code requirements.

Flush Floor Drip Piping Example for Ultra Low Front Cases



Elbow is to be oriented toward rear of case. Install elbow to tee, place elbow on hub. Push elbow until it meets the liner.

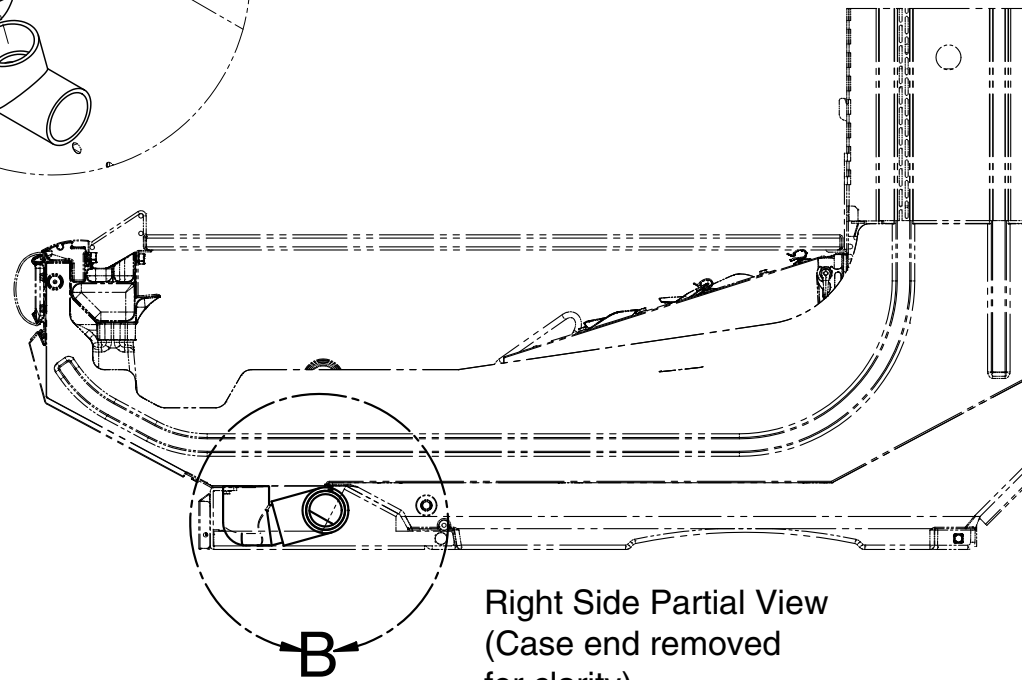
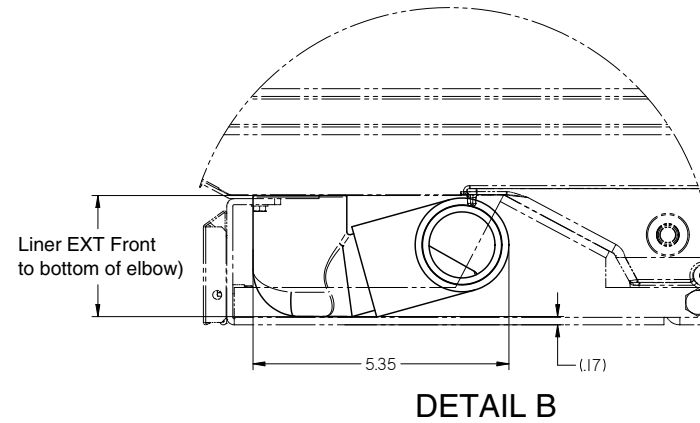
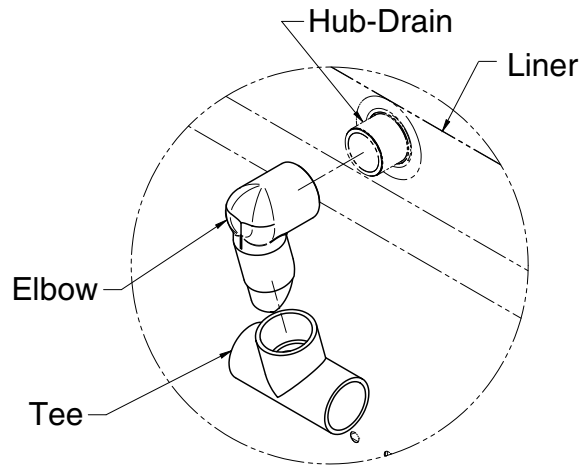

Right Side Partial View
(Case end removed
for clarity)

Optional Waste Outlet Drip Piping Example for Ultra Low Front Cases

There is limited space underneath the case for piping ultra low front cases. If there is a waste outlet in the floor, use the ultra low front piping kit. This extends the splashguard forward. Follow the waste outlet location drawings on the following pages to install the drip piping in the correct location. This kit can also be used to pipe multiple cases to a single floor waste outlet/sink.

ITEM NUMBER	TITLE	QUANTITY	COMMENTS
1	ADAPTER-.750 SKT F X M 90 ELBOW	1	FACTORY INSTALLED
2	ELBOW-22.5 DEG .750 SOCKET SCH40	2	FACTORY INSTALLED
3	PIPE-.750 X 2 PVC SCH40	1	FACTORY INSTALLED
4	TEE-.750 SOCKET SCH 40 PVC	1	FACTORY INSTALLED
5	BUSHING-.750 X .5 SPIG X FNPT RDCR	1	FIELD INSTALLED
6	PLUG-.5 MNPT SCH 40 PVC	1	FIELD INSTALLED
7	ELBOW-90 DEG .750 SOCKET SCH40	3	FIELD INSTALLED
8	PIPE-.750 X 4.5 PVC SCH40	4	FIELD INSTALLED

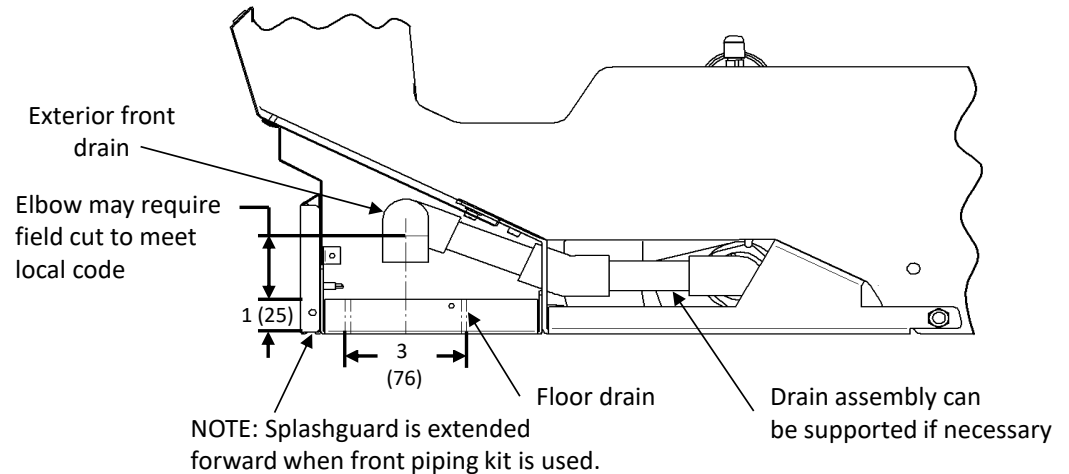
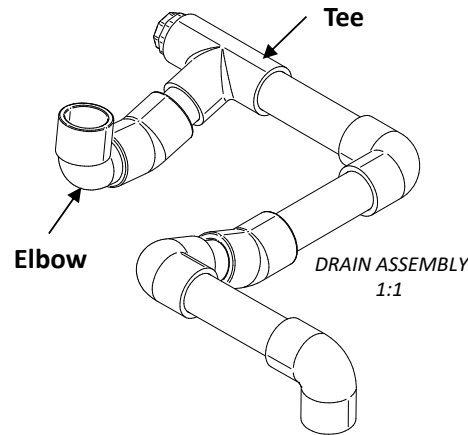
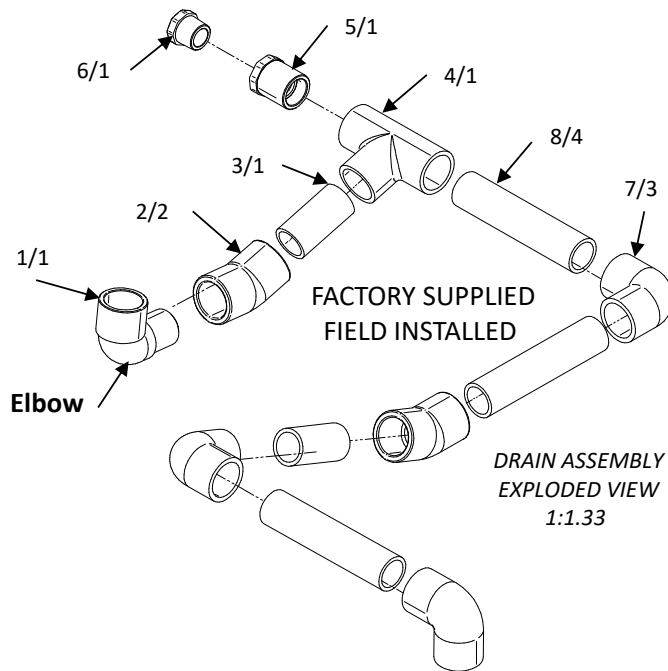

Elbow trap is to be oriented toward rear of case. Install elbow to tee, place elbow on waste outlet of case. Push elbow trap until it meets the liner.

Drain Location with Drain Extension Kit (Dimensions in Inches)

Standard Depth Models Ending in SU	4-foot	6-foot	8-foot	12-foot
(A) RH end of case to center of original waste outlet	24 1/8	24 1/8	24 1/8	72 1/4
(B) RH end of case to center of relocated waste outlet (with drain extension kit) *	13 3/4	13 3/4	13 3/4	61 7/8
(C) Back of case to center of original waste outlet	33 1/2	33 1/2	33 1/2	33 1/2
(D) Back of case to center of relocated waste outlet (with drain extension kit)	38 1/4	38 1/4	38 1/4	38 1/4
(E) Back of case to the back of the relocated splashguard (with drain extension)	41	41	41	41

* Drain Extension shown piped to the right but may be piped either direction

Drain Location with Drain Extension Kit (Dimensions in Inches)

Narrow Depth Models Ending in NU	4-foot	6-foot	8-foot	12-foot
(A) RH end of case to center of original waste outlet	24 1/8	24 1/8	24 1/8	72 1/4
(B) RH end of case to center of relocated waste outlet (with drain extension kit) *	13 3/4	13 3/4	13 3/4	61 7/8
(C) Back of case to center of original waste outlet	28 5/8	28 5/8	28 5/8	28 5/8
(D) Back of case to center of relocated waste outlet (with drain extension kit)	33 1/2	33 1/2	33 1/2	33 1/2
(E) Back of case to the back of the relocated splashguard (with drain extension)	35 1/8	35 1/8	35 1/8	35 1/8

* Drain Extension shown piped to the right but may be piped either direction

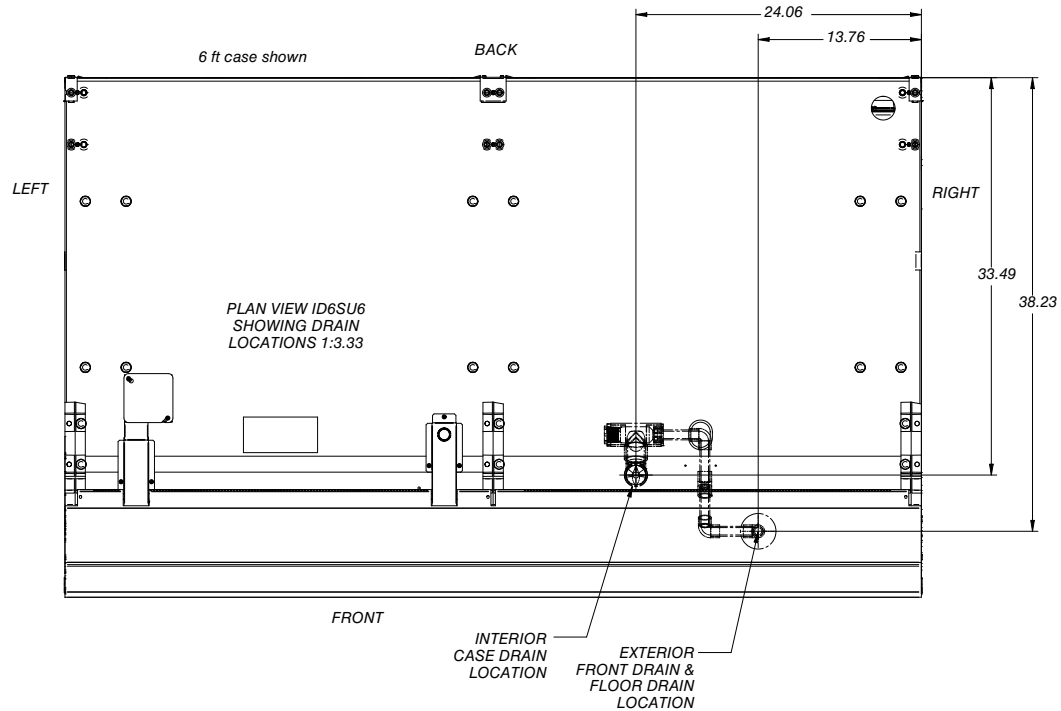
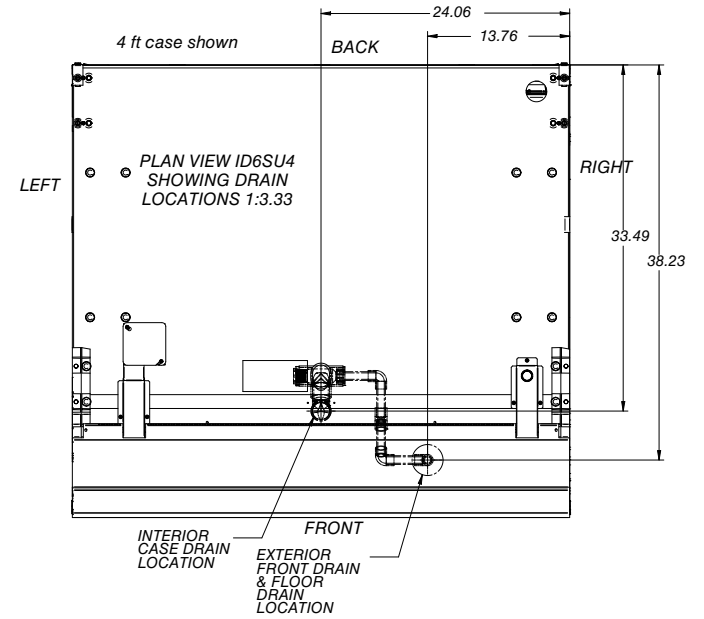

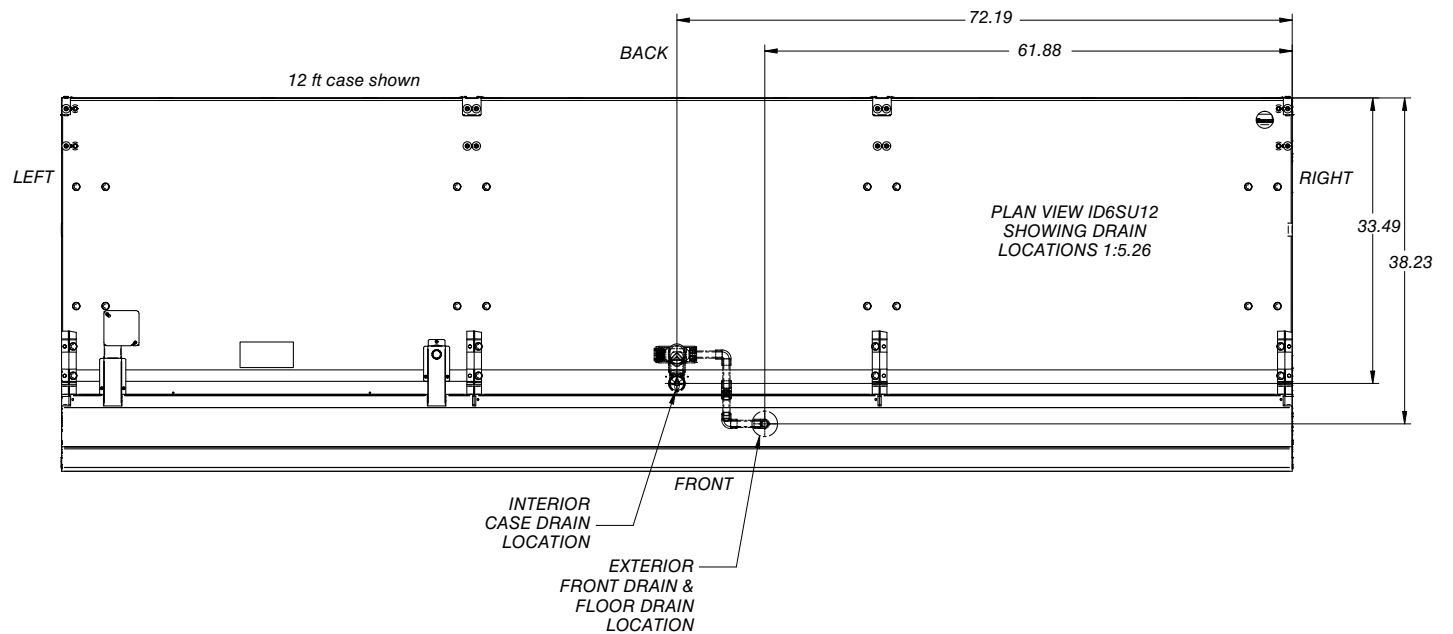
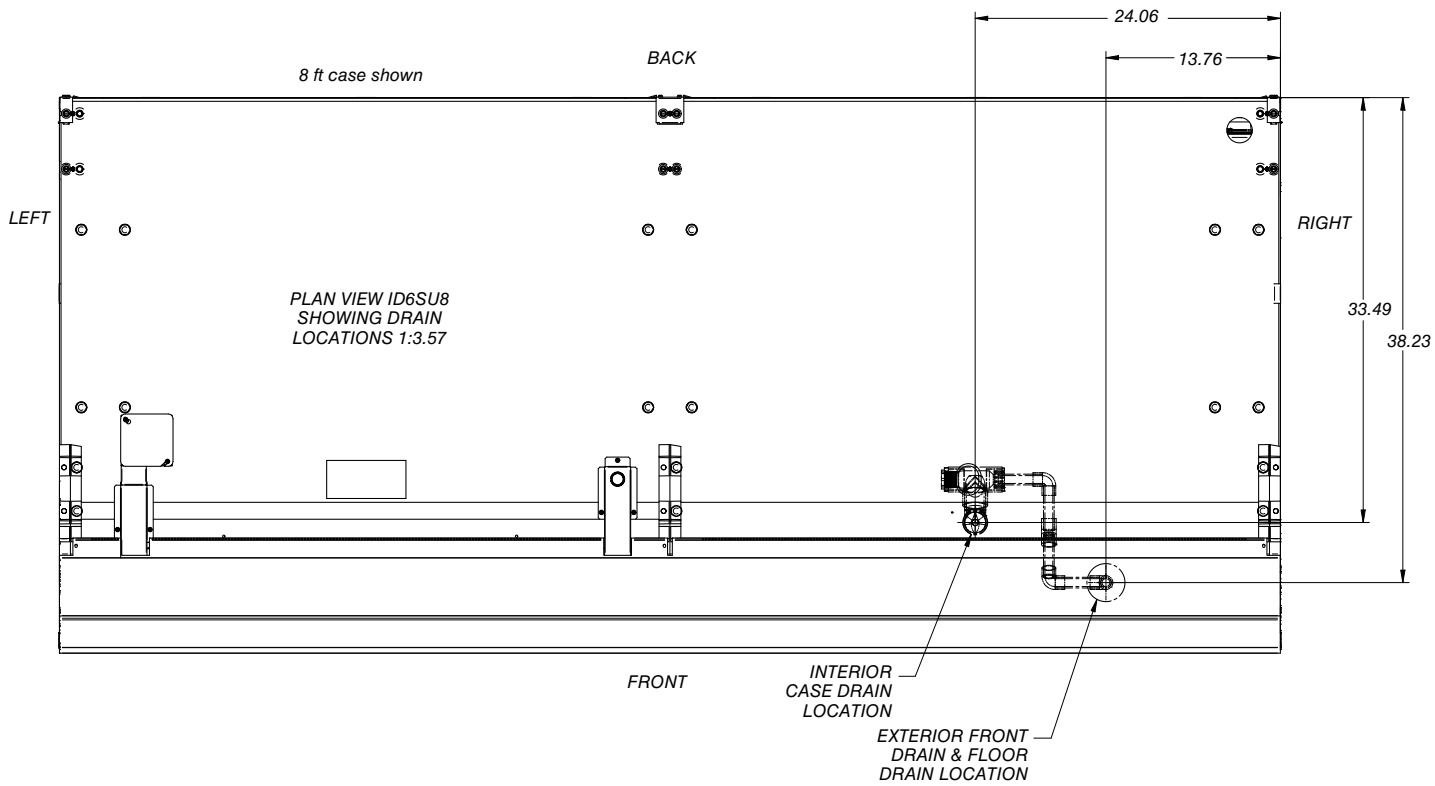

FINAL ALIGNMENT / FIT & FINISH

Fascia Top Cap Alignment

Applies to (IP4/IM5/ID5/ID6/IC6)

Fascia Top Cap can slide toward the center of (multideck) case lineups to eliminate gaps.

1. Pull fascia top cap to uncover fixing screws.

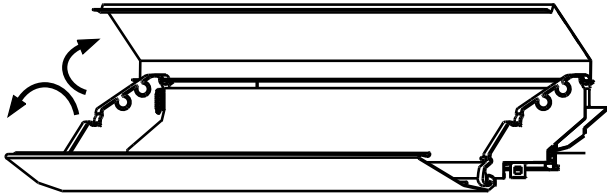

2. Loosen the screws of fascia top cap.
3. Move fascia top cap towards the lineup center. Tighten the screws after finishing the alignment.
4. Snap fascia top cap to closed position.
5. Install fascia trim (optional) between joints and at ends. Hook at bottom first, then snap top into place.

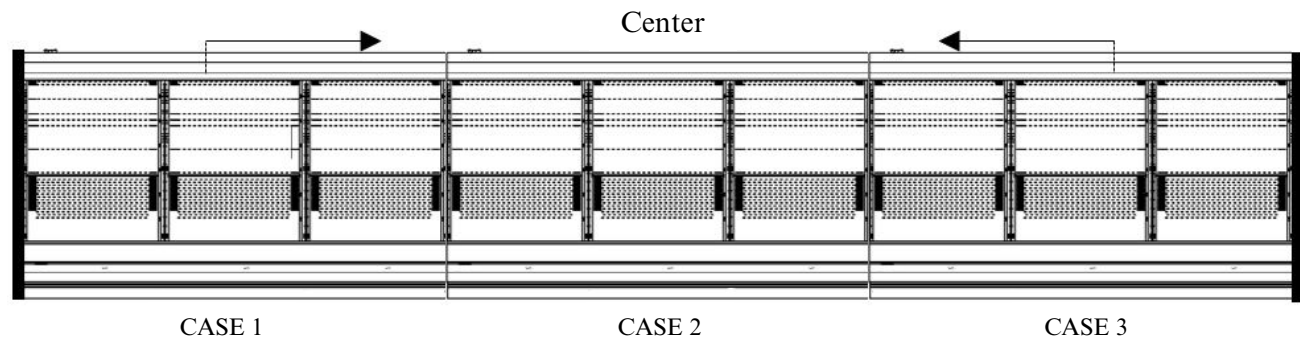
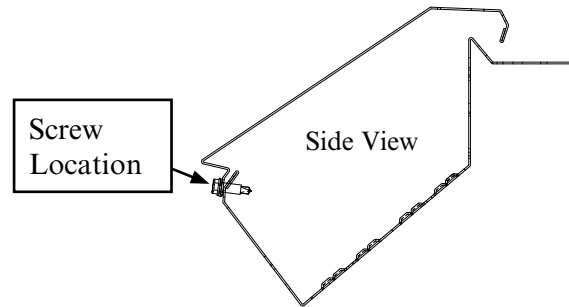
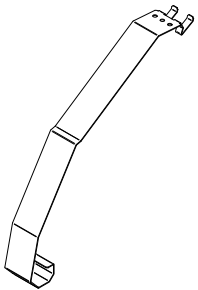

Fascia Panel Alignment

Applies to (IP4/IM5/ID5/ID6/IC6)

Fascia panels can slide toward the center of (multideck) case lineups to eliminate gaps.

1. Slide fascia panels toward lineup center as shown in the illustration below.
2. Place optional fascia trim between fascia joints between end panel and fascia and between case lineup joints. Install tape to joint first, then attach bottom and top fascia trim.

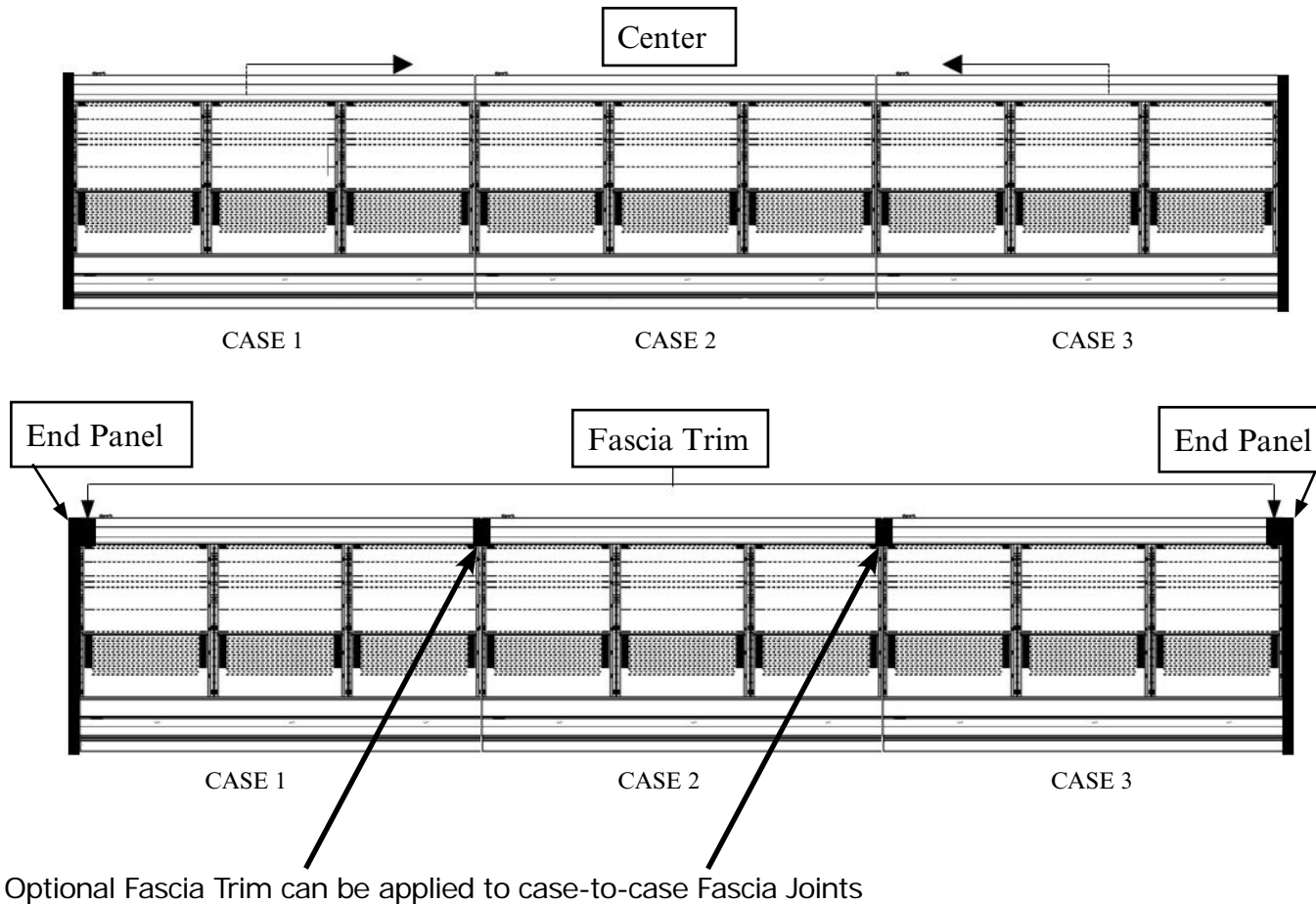
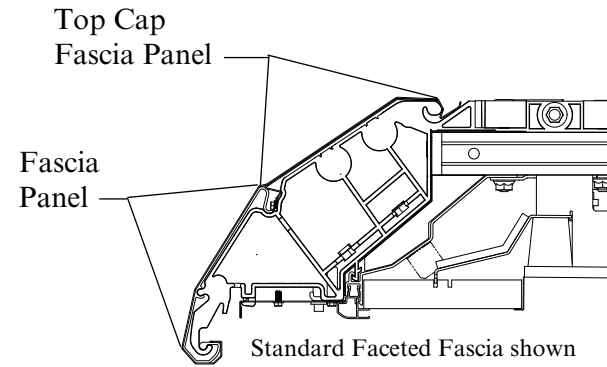

Fascia Panel Alignment Applies to (IC2 / IC2X / IC3)

Fascia panel can slide toward the center of case lineups to eliminate gaps.

Fascia trim is then needed at the end of either side of the lineups to eliminate gaps at the ends.

1. Loosen the fascia screws located at the inner bottom of fascia.
2. Slide fascias toward the lineup center to eliminate gaps between fascias and tighten the screws.
3. Place optional fascia trim between fascia joints between end panel and fascia and between case lineup joints. Install tape to joint first, then attach bottom and top fascia trim.

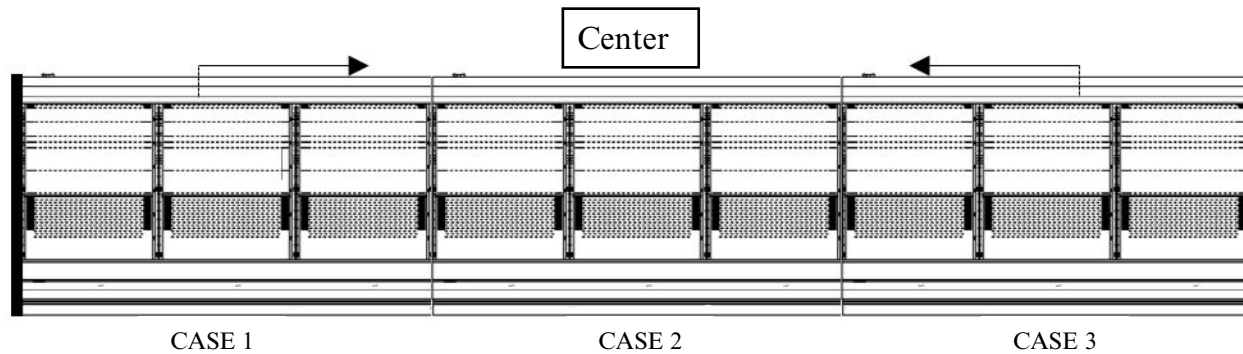
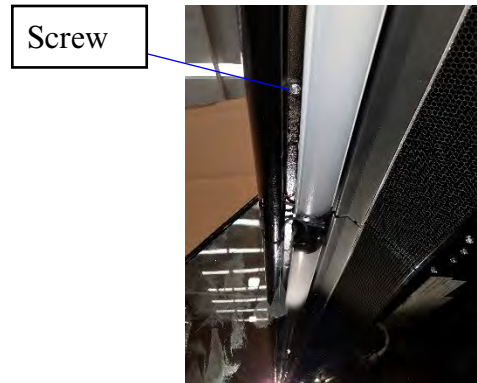

Front Panel Alignment

Front Panels can slide toward the center of (multideck) case lineups to eliminate gaps.

1. Loosen the front panel screws located at the bottom of Front Panel.
2. Slide front panel towards the lineup center to eliminate gaps between front panels. Tighten the screws after finishing the alignment.
3. Place optional front panel trim at case lineup joint. Install tape to joint first, then attach front panel trim.

NOTE Remove Front Skid Brace before aligning Front Panels. Align Panels before installing the Splashguard Front and Bumpers.



Front Panel Screw

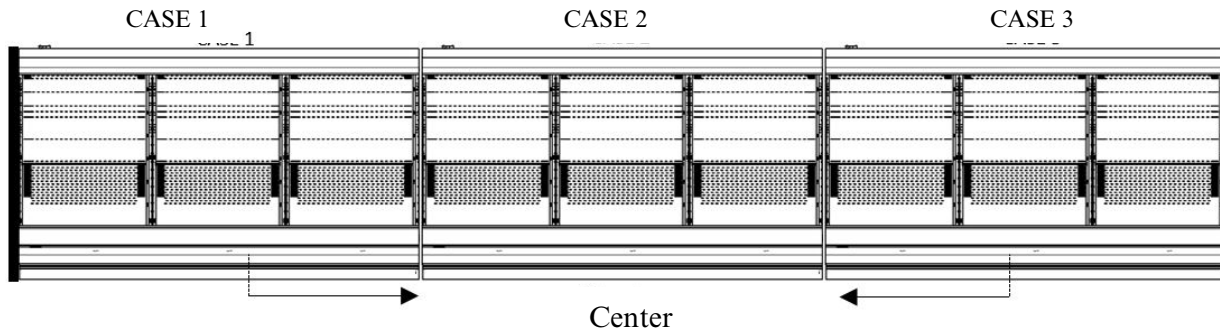
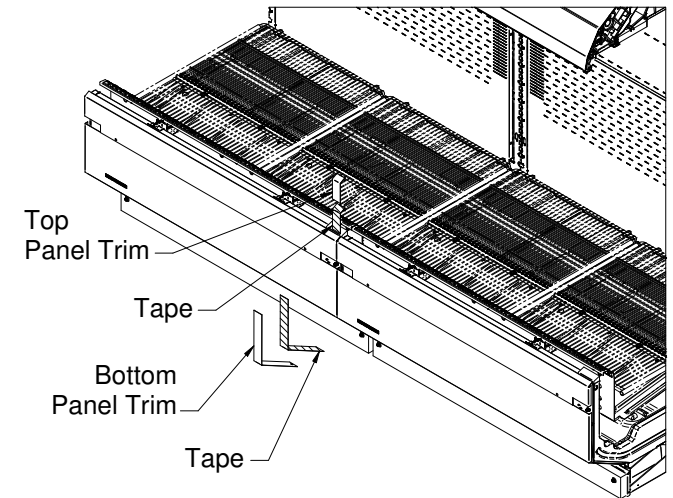
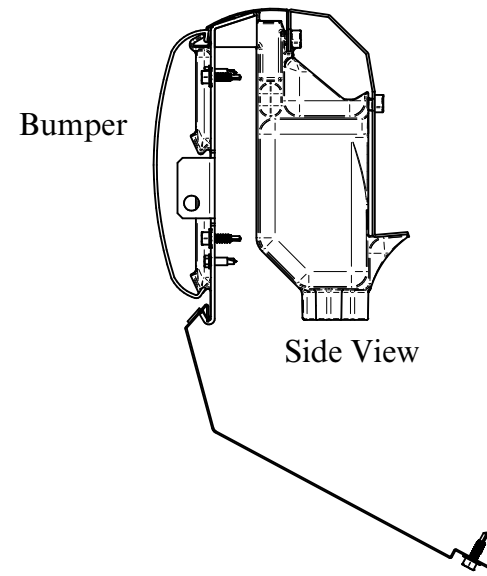

INSTALLING END SPLASHGUARDS

(Standard Case)

1. End splashguard must be slid in from the front, so that it fits behind the end panel. Attach end splashguard brackets to base at locations shown in the illustrations below.
2. Align forward edge of splashguard end panel to the inside of front splashguard. Fasten end splashguard to bracket with screws.
3. If end assembly bolt is loosened & seal broken when installing end splashguard, apply caulk to seal end assembly to inside of case.



End Splashguard Panel fits to the inside of End Assembly.



IMPORTANT

Install end splashguard before installing front splashguards.

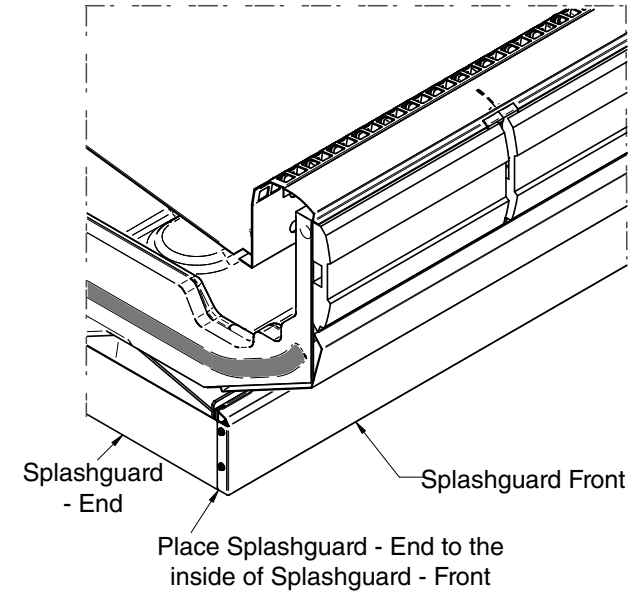
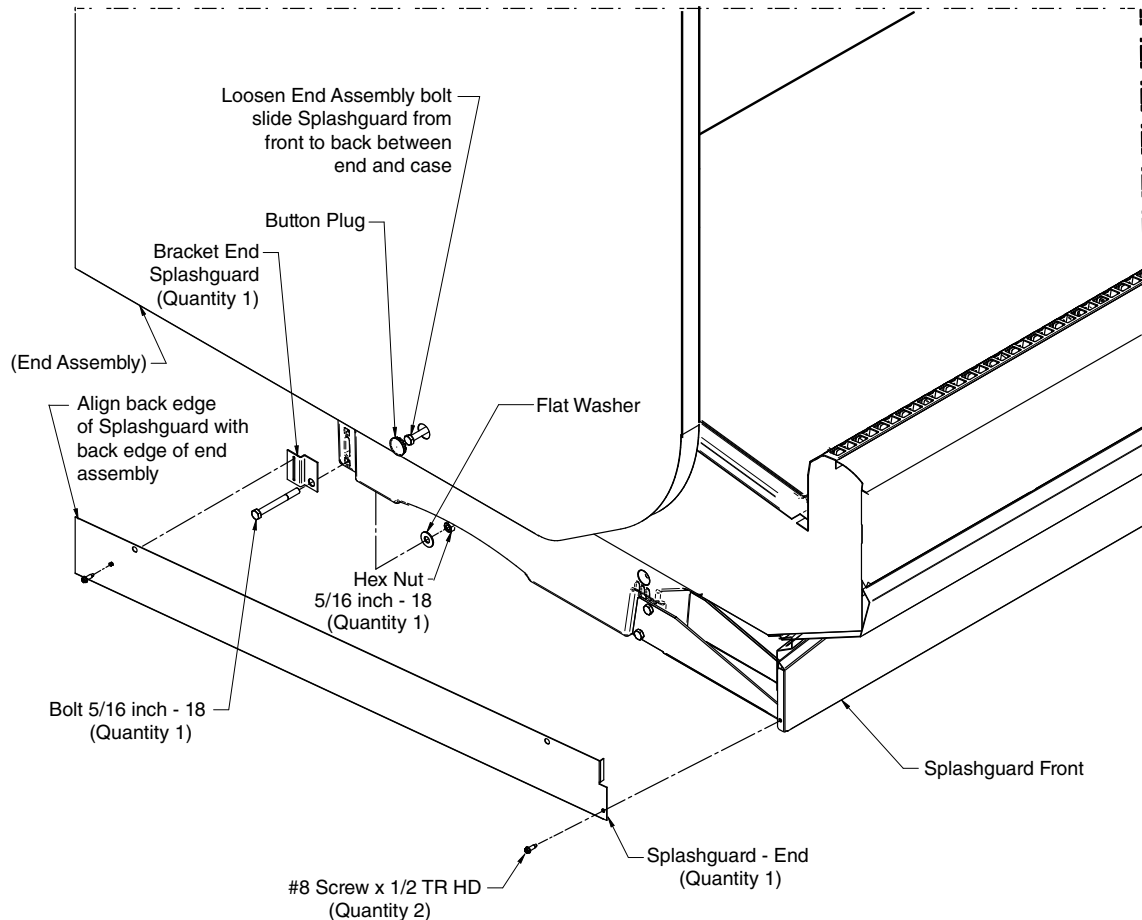

Installing End Splashguards

(Detail below for cases with elevated case heights.)

1. End splashguard must be slid in from the front, so that it fits behind the end panel. Attach end splashguard brackets (2) to base at locations shown in the illustrations below.
2. Align forward edge of splashguard end panel to the inside of front splashguard. Fasten end splashguard to bracket with screws.

NOTE

End Splashguard Panel fits to the inside of End Assembly.



IMPORTANT

Install end splashguard before installing front splashguards.

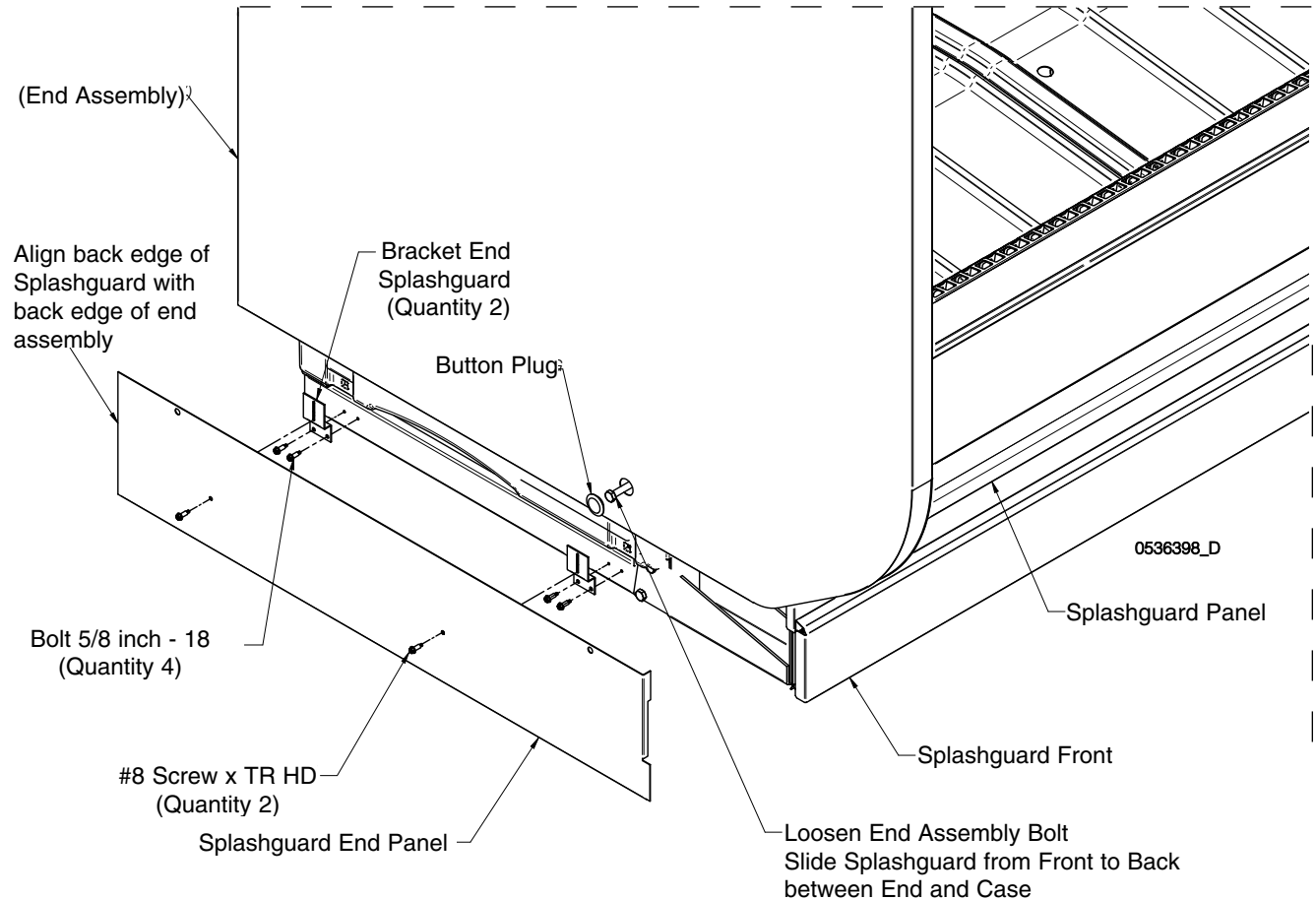
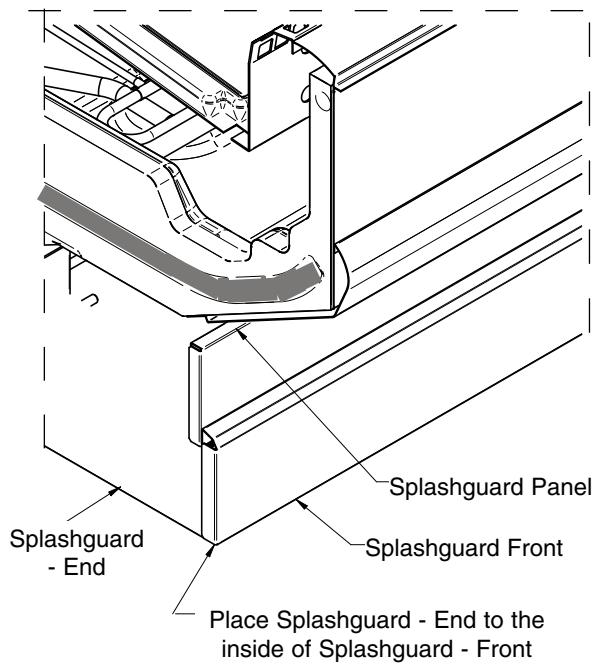

INSTALLING SPLASHGUARD BRACKETS

Position splashguard brackets at the front base (legs) of the merchandiser near the floor. Loosely assemble Splashguard Bracket using #8 x 5/8 inch SM screws as shown in Detail A below. More detail of splashguard installation shown on next page.

⚠ WARNING

» Use caution when working around refrigeration lines or water lines. Damage to equipment and/or personal injury could occur.

Splashguard Bracket and Panel Installation (12 ft Shown)

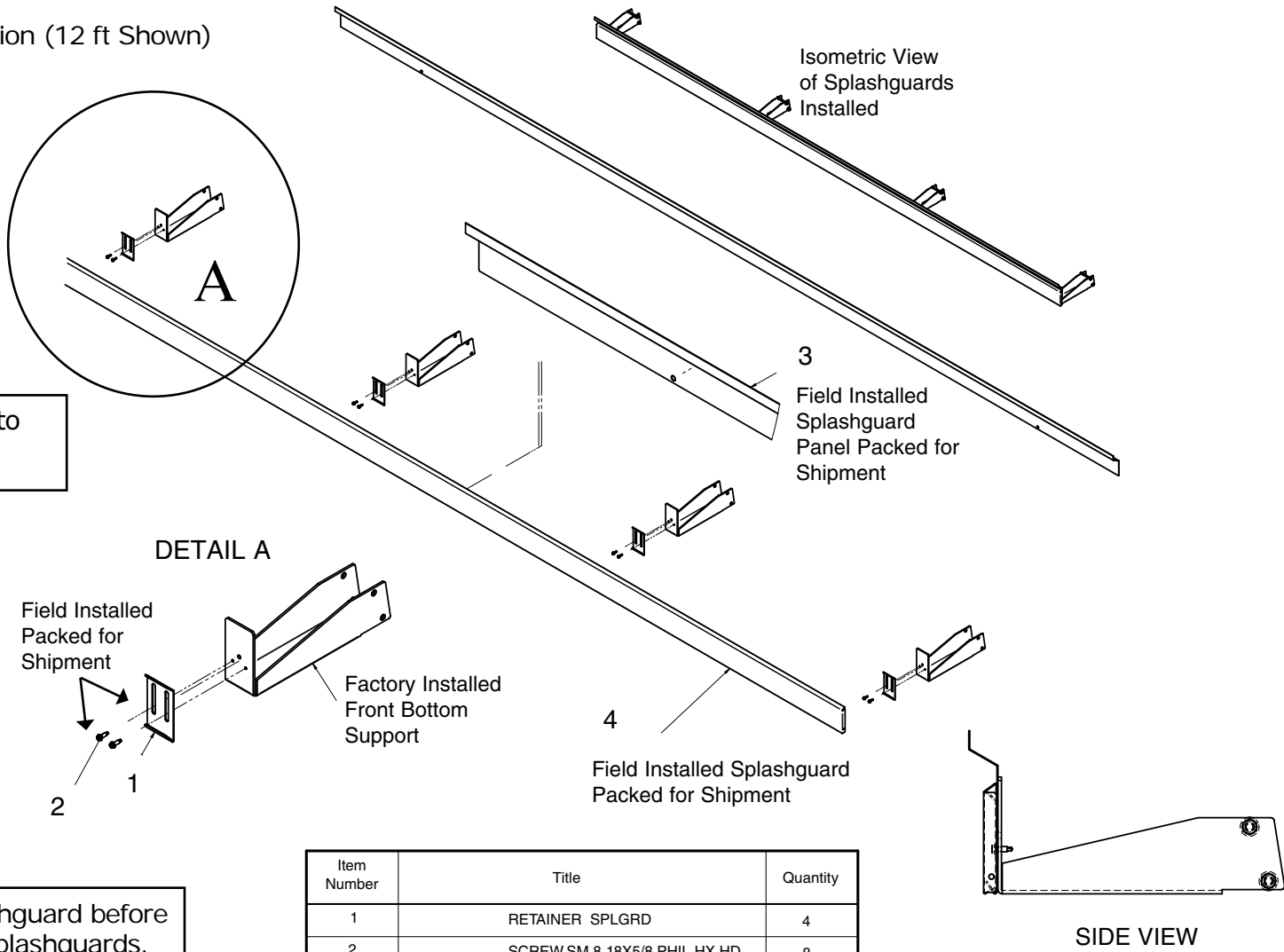

NOTE End Splashguard Panel fits to the inside of End Assembly.

IMPORTANT Install end splashguard before installing front splashguards.

Item Number	Title	Quantity
1	RETAINER SPLGRD	4
2	SCREW SM 8 18X5/8 PHIL HX HD	8
3	PANEL 5.4" SPLGRD CL/O 12FT	1
4	SPLASHGUARD FRONT 12FT	1

INSTALLING SPLASHGUARDS

(Retainers and Panels)

Splashguards are shipped inside each merchandiser, 4 brackets for 12 ft case, 3 for 6 ft , etc. After merchandisers have been leveled and joined, and all drip piping, electrical and refrigeration work has been completed, install the splashguard.

To Install Splashguards:

1. Check to be sure that all splashguard brackets are level with the floor. Refer to previous page for additional exploded view pictures.
2. Loosely attach the lower splashguard retainer bracket using # 8 SM screws (1).
3. Install close-off panel as shown in (2 & 3). Slide splashguard close-off panel between the bracket and lower front support.
4. Raise the splashguard close-off panel to where the top fits into bend on the lower color panel, then tighten the splashguard brackets.
5. Fit the lower splashguard into the slots on the lower splashguard retainer. Lower splashguard snaps into place (4).

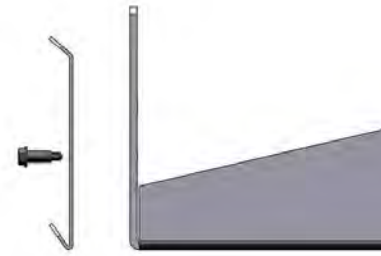

1.

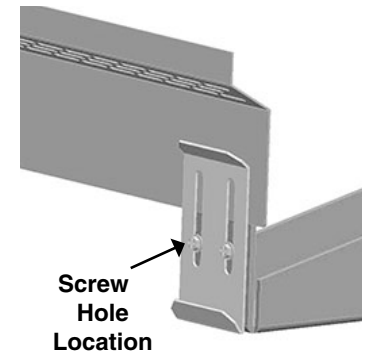

2.

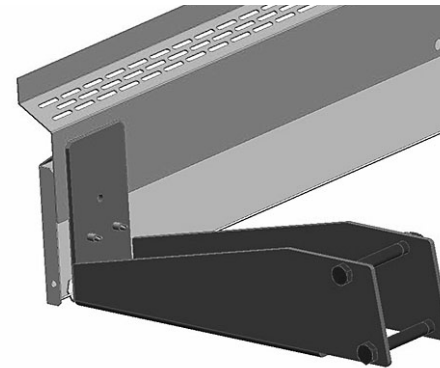

Rear View

3.

To install Optional cove trim to the splashguard:

1. Remove all dirt, wax and grease from the area of the splashguard where adhesion will be necessary to ensure a secure installation.
2. Apply a good contact cement to the cove trim and allow proper drying time according to the directions supplied with the cement.
3. Install the trim to the splashguard so that it is lying flush with the floor. Do not seal the trim to the floor.
4. If required by local health codes the Cove Trim may be sealed to the floor, using a silicone type sealer. Sealant must be removed and replaced when servicing.

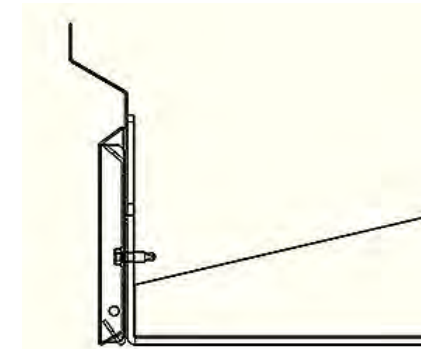

4.

Splashguard Alignment to eliminate gaps in cases Line-Up

1. Slide Splashguard towards line-up center to eliminate Splashguards gaps.

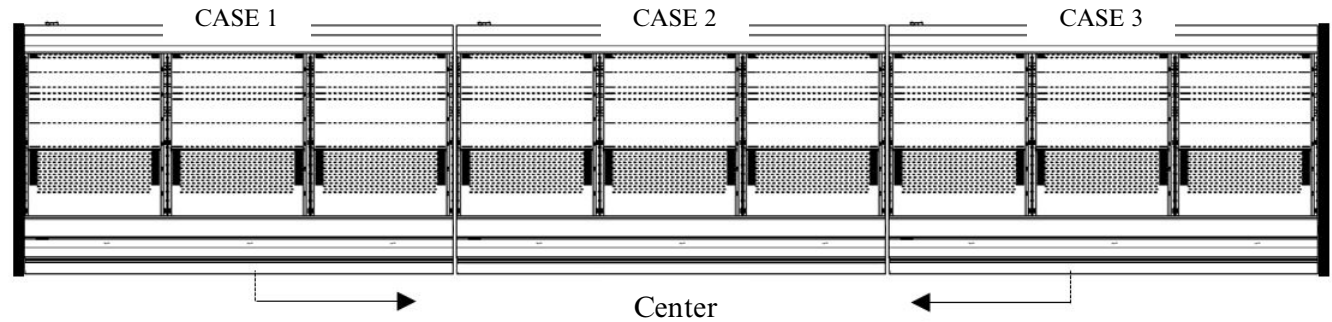

INSTALLING SPLASHGUARD BRACKETS ULTRA-LOW FRONT CASES

Position splashguard brackets at the front base (legs) of the merchandiser near the floor. Loosely assemble Splashguard Bracket using #8 x 5/8 inch SM screws as shown in Detail A below.

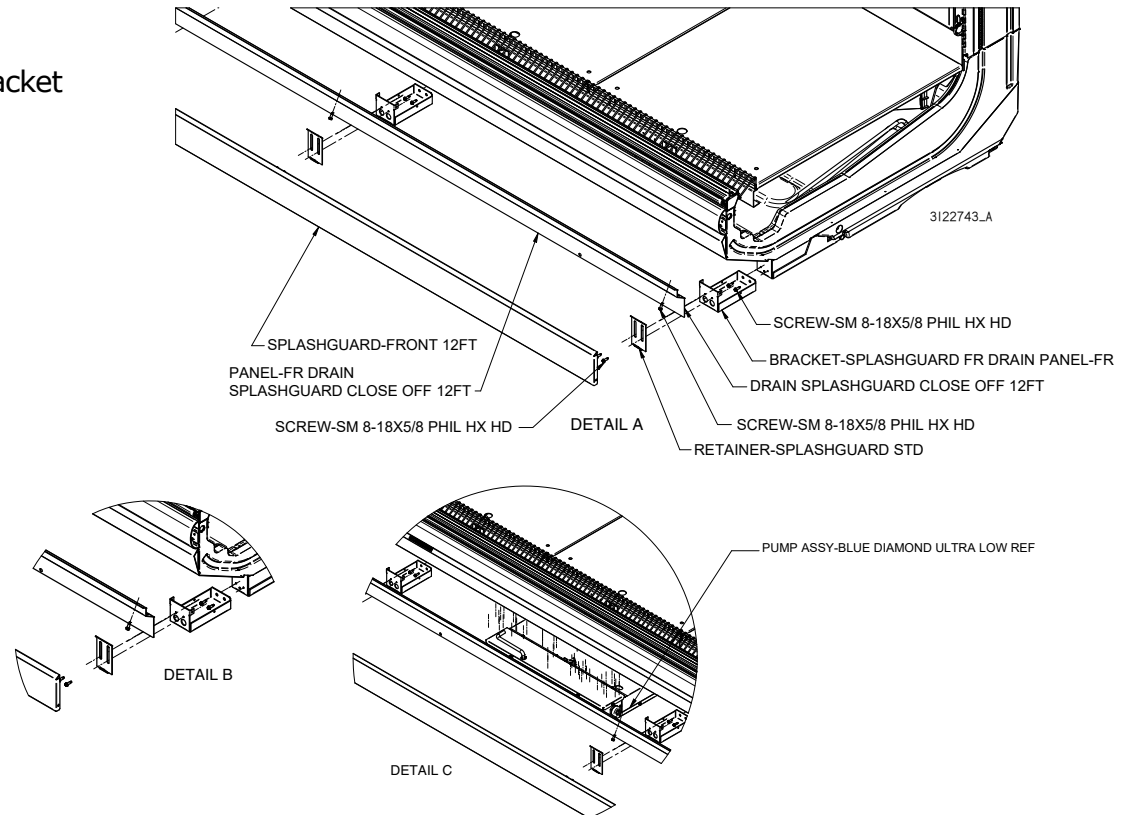
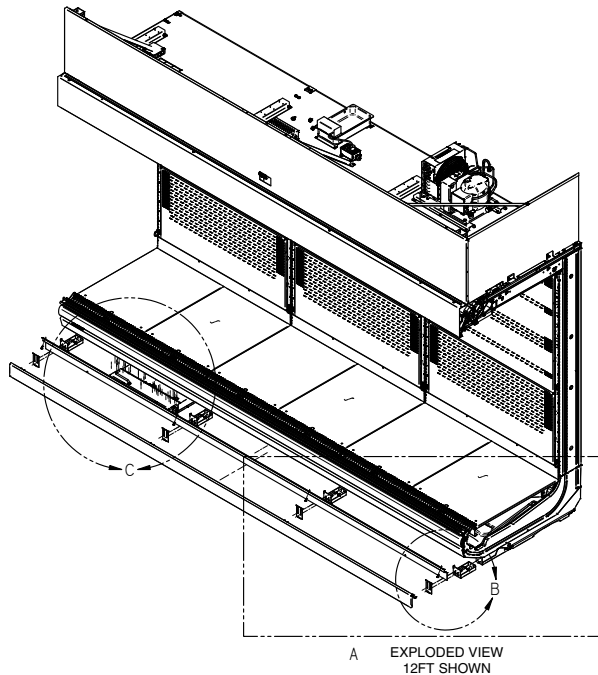

STARTUP / OPERATION

STARTUP / OPERATION

See the merchandiser's Technical Data Sheet (TDS) for refrigerant settings and defrost requirements. Bring merchandisers down to the operating temperatures listed on the data sheet.

Excessive ambient conditions may cause condensation and therefore sweating of doors. Facility operators should monitor doors and floor conditions to ensure safety of persons.

Each four-foot section has its own evaporator coil and pre-set adjustable thermostatic expansion valve (TEV). Evaporator super heat must be checked on all cases during startup. The TEV has been factory set to provide the recommended performance settings as specified on merchandiser data sheets. Only a certified technician should adjust these valves.

⚠ CAUTION

- » Always be sure to replace TEV Cap, missing TEV Cap could result in refrigerant loss.
- » Case must operate for 24 hours before loading product.

⚠ WARNING

- » Case ventilation openings must be clear of any obstructions. Do not damage the refrigerant circuit.

LOAD LIMITS

Each merchandiser has a load limit. Shelf life of perishables will be short if load limit is violated. At no time should merchandisers be stocked beyond the load limits indicated.

STOCKING

Do not block honeycomb or return air grille. Product should not be placed inside of merchandisers until merchandiser is at proper operating temperature. Proper rotation of product during stocking is necessary to prevent product loss. Always bring the oldest product to the front and set the newest to the back.

Air discharge and return flues must remain open and free of obstruction at all times to provide proper refrigeration and air curtain performance. Do not allow product, packages, signs, etc. to block these grilles. Do not use non-approved shelving, baskets, display racks, or any accessory that could hamper air curtain performance.

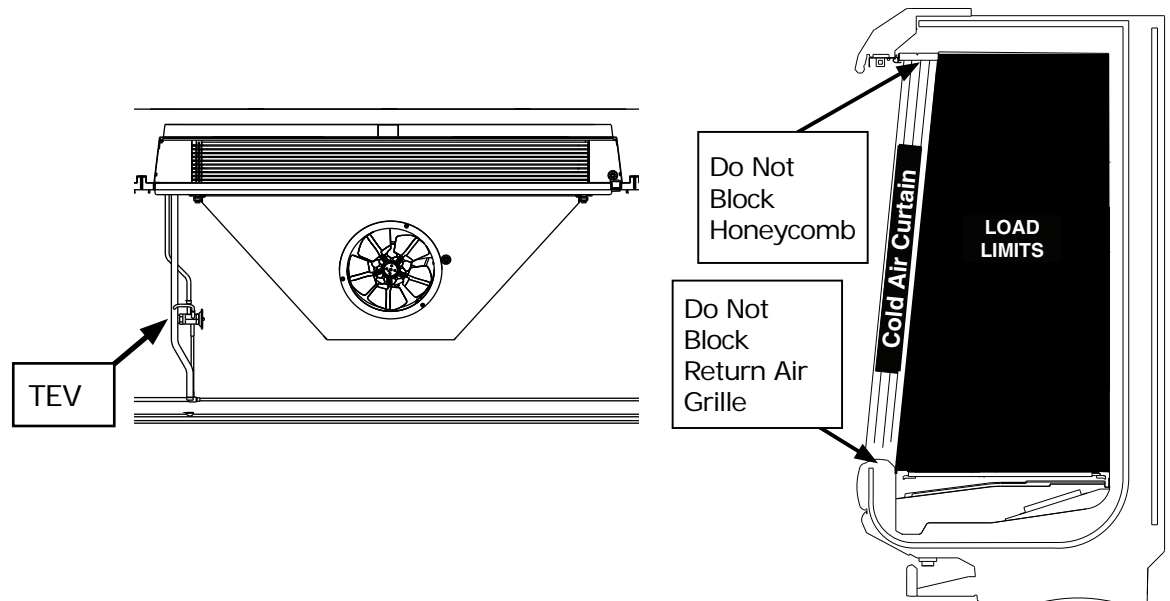

SHELF MAXIMUM WEIGHT LIMITS

Hussmann merchandiser shelves are designed to support the maximum weight load limits as indicated in this table.

Exceeding these maximum weight load limits may cause damage to the shelf or shelves, damage to the merchandiser, damage to store products, and potentially create a hazardous condition for customers and staff. Exceeding the indicated maximum weight load limits constitutes misuse as described in the Hussmann Limited Warranty.

Weight Limits for Merchandiser Shelving

Nominal Shelf Depth	Maximum Load Limit
12 in. (305 mm)	125 lb (56.7 kg)
14 in. (357 mm)	125 lb (56.7 kg)
16 in. (406 mm)	200 lb (90.7 kg)
18 in. (457 mm)	200 lb (90.7 kg)
20 in. (508 mm)	250 lb (113.4 kg)
22 in. (559 mm)	250 lb (113.4 kg)
24 in. (610 mm)	250 lb (113.4 kg)
Heavy Duty Beverage Shelf 16 in. (406 mm)	300 lb (136 kg)
Heavy Duty Beverage Shelf 18 in. (457 mm)	320 lb (145.1 kg)
Heavy Duty Beverage Shelf 20 in. (508 mm)	350 lb (158.8 kg)
Heavy Duty Beverage Shelf 22 in. (559 mm)	350 lb (158.8 kg)
Heavy Duty Beverage Shelf 24 in. (610 mm)	350 lb (158.8 kg)

*Shelf load limits at 0° tilt

Merchandiser Shelf Depths

	Recommended	Maximum
Narrow (37 in. Merchandiser Depths)	16 in. (406 mm)	18 in. (457 mm)
Standard (42 in. Merchandiser Depths)	22 in. (559 mm)	24 in. (610 mm)

MULTIDECK SHELF CONFIGURATION

Shelves are individually mounted in 1 in. (25 mm) increments and have two-, three-, or four-position brackets, permitting shelves to be placed in a flat or down-tilt position (see illustration). Front product stops are recommended when shelves are placed in the down-tilt position.

Case performance will be degraded if peg shelves are used without baffles. Unauthorized specialty shelving may cause poor merchandiser performance. Consult your Hussmann representative to ensure optimum performance of Hussmann equipment.

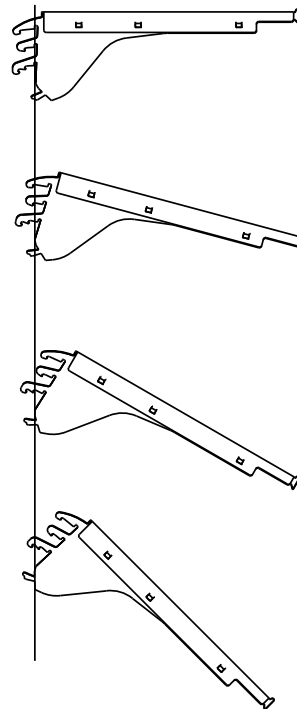

4-position Shelf

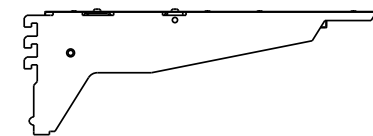

Beverage Shelf

INSTALLING CASESHIELDPTM(S) (OPTIONAL)

The CaseShieldPTM is installed on the front edge of shelves as a replacement to existing price tag molding (PTM). It acts as a guide for the air from the discharge to the return air grille to reduce turbulence and save energy.

To install the CaseShieldPTM:

Slide the CaseShieldPTM onto the shelf as shown in (B) below.

NOTE: For use only with straight shelves. Do not apply CASESHIELD PTM(s) to angled shelves.

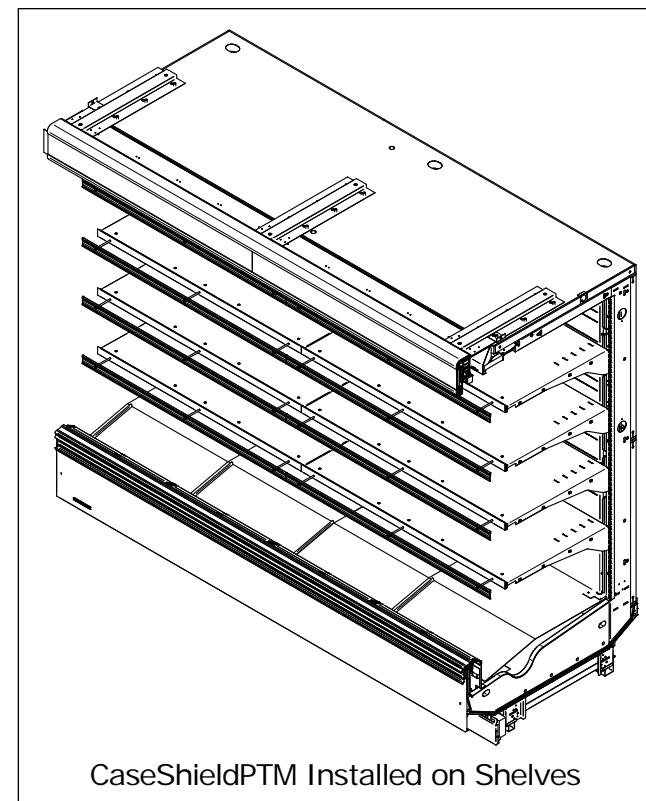

CaseShieldPTM Installed on Shelves

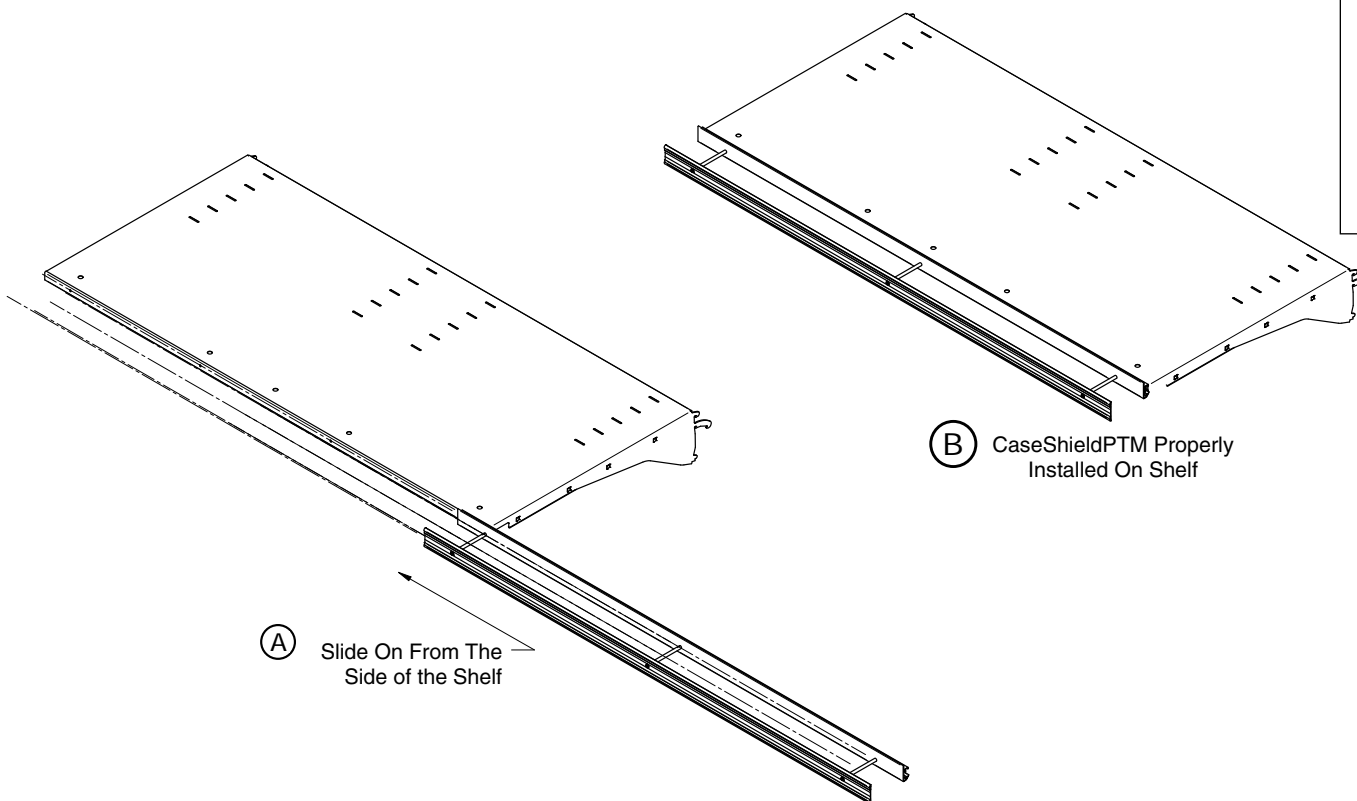

(A) Slide On From The Side of the Shelf

(B) CaseShieldPTM Properly Installed On Shelf

LED FIXTURES

These merchandisers are equipped with 24 volt DC power supplies that power the LEDs. The power supplies are located in the canopy raceway. Power supplies are located in the field connection box for wedges. LEDs work well for dimming or on/off operation using an occupancy sensor (optional kits). Replace lights with like fixtures. Contact your Hussmann representative for more information.

They can be turned on and off in a cold environment with no warm-up time and no negative impact on lamp life.

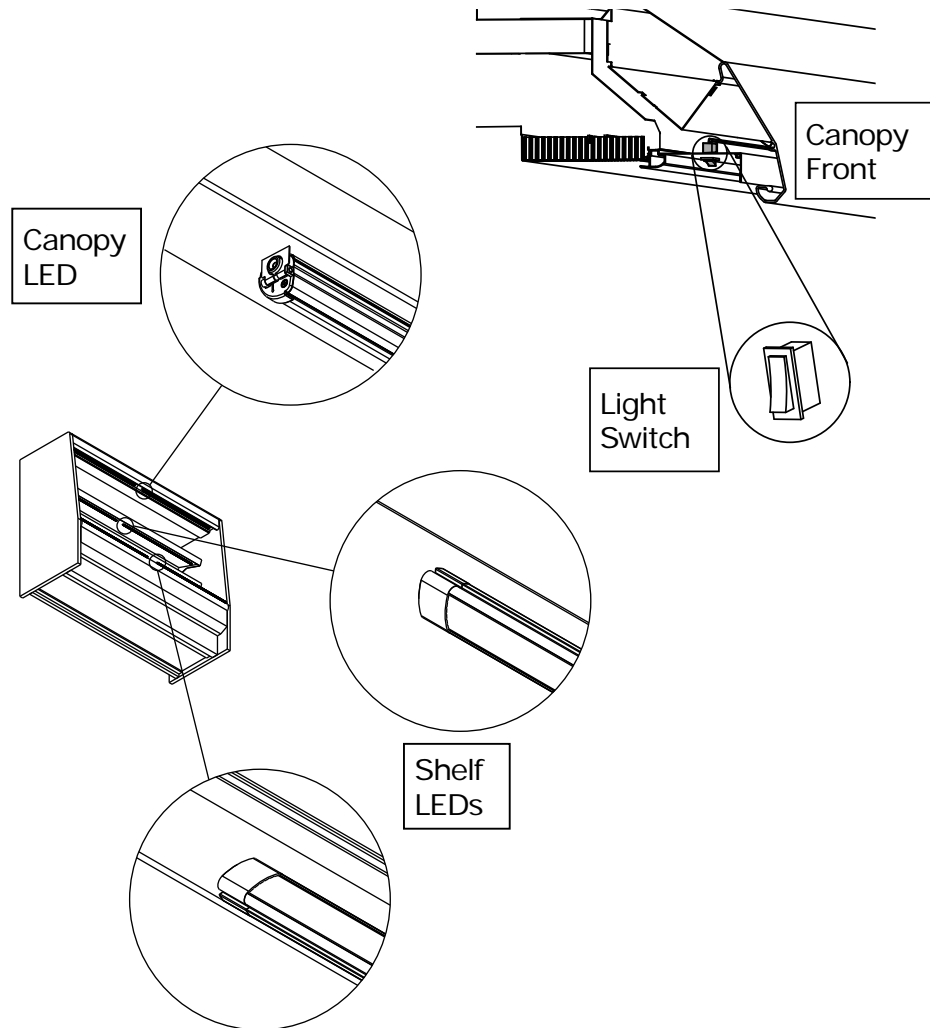

⚠ WARNING

— LOCK OUT / TAG OUT —

» To avoid serious injury or death from electrical shock, always disconnect the electrical power at the breaker when servicing or replacing any electrical component. This includes, but is not limited to, such items as doors, lights, fans, heaters, and thermostats.

PROCEDURE FOR INSTALLING LIGHTED SHELVES

Follow these instructions to ensure good contact between male and female connectors.

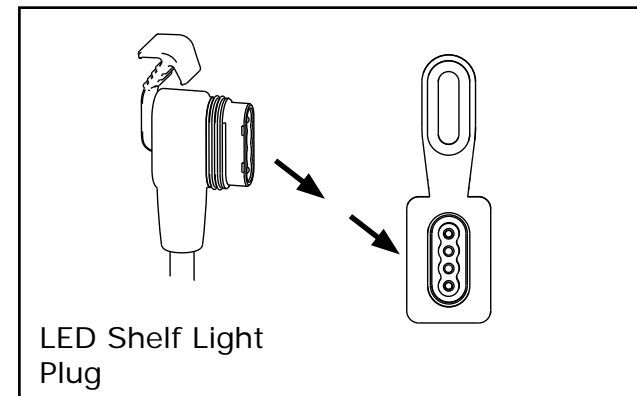

1. Remove any products from the case and place in cooler. Shut off power to the merchandiser.
2. Turn off Canopy Light Switch. Remove all packed shelves.

- Engage each power socket cap, and ensure that each cap is fully seated before cleaning. Ensure the proper seating of the cap at all times when the plug is not engaged.

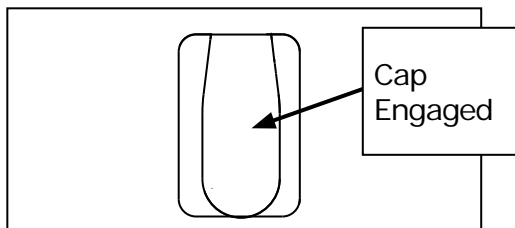

- Clean the merchandiser as described in the Care and Cleaning paragraphs of Section 5 — Maintenance. Keep liquid out of sockets. (Allow merchandiser shelves to dry before turning on shelf power.)
- Verify power to the merchandiser is turned ON. Verify that the merchandiser light switch is turned OFF. The switch is located in the canopy, on the left side.
- Refer to the illustration at the top of the next page. Note that other models will have fewer rows of shelves. Starting from the left-hand (where applicable) bottom section, choose the location for the first shelf, X-1.
- Secure the shelf in the slotted upright. Make certain that the shelf is level and that ends are in the same slot on the left and right upright. Markings on the shelf uprights indicate the proper shelf notch for each shelf location. It is important that shelf brackets be properly seated in the slotted upright.
- Working from left to right (where applicable), install the next shelf, X-2, to the right of the first shelf you installed. Always work from left to right and from the bottom up in each 90° wedge case.
- After each shelf on the bottom row is in position, be sure to remove the cap and insert the shelf connector. Push firmly.
- Turn ON the wedge case light switch after the entire bottom row has been installed. The shelf lights should light.

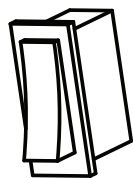

If an LED shelf light does not operate:

- Turn off light switch.
- Remove and firmly re-insert each shelf plug.
- Turn on light switch.

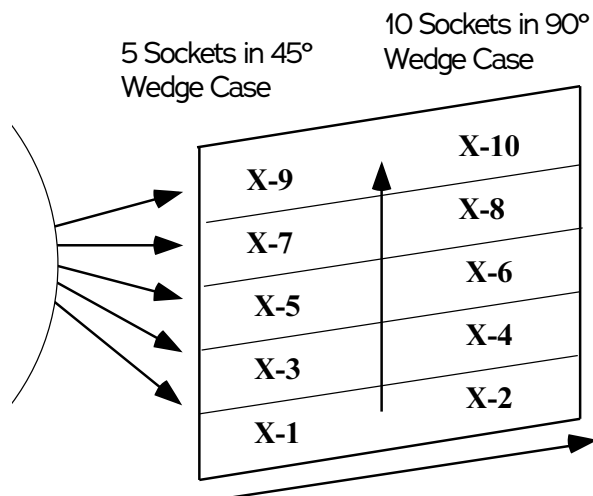

Always work Left to Right, and Bottom to Top

If lights do not operate after checking the items listed above, contact the installation contractor.

- Using the row of shelves just installed as support, set the next shelf, X-3, in the desired location. Remove the cap and insert the shelf plug. Continue working left to right installing shelf X-4.

Note: Since the location for the remaining shelves, X-4 to X-10, may be directly over the rear wall receptacle, the shelf should be plugged in before engaging brackets in the uprights. The lower shelf will support the weight of the next shelf until it is plugged in. After installing each shelf, verify that its plug is properly connected to its rear wall receptacle. Continue working row by row, bottom up, left to right.

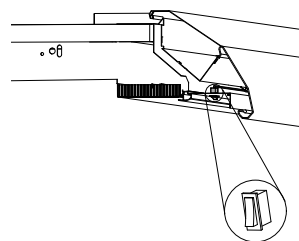

If a shelf is plugged in and the lamp does not work, verify the case light switch is ON.

Shelf LED clips must be first inserted into the front lip underneath the shelf as shown at left. Next the retaining clip is "snapped on" to the rear of the LED clip.

SHELF LED CLIP INSTALLATION

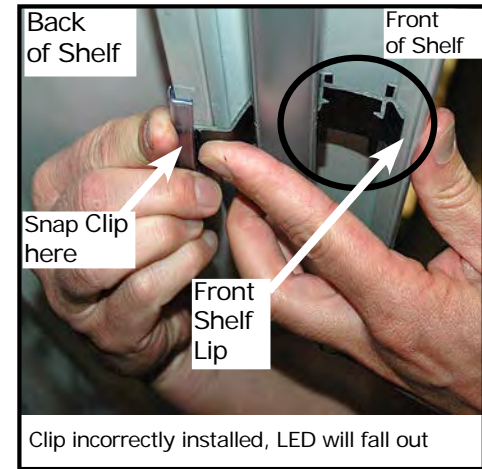
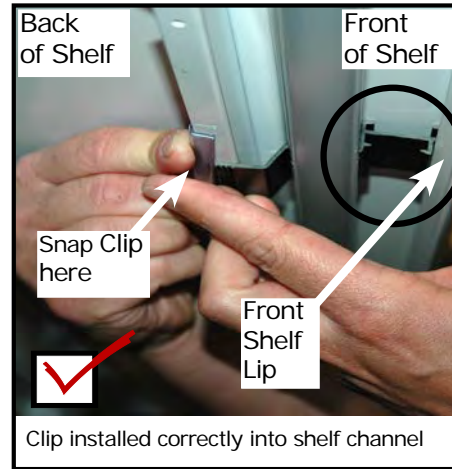

Use caution when installing Product Stops. Product stop legs must be inserted at an angle. When product leg goes through the shelf, it must rest BEHIND the LED shelf light as shown below.

PRODUCT STOP INSTALLATION

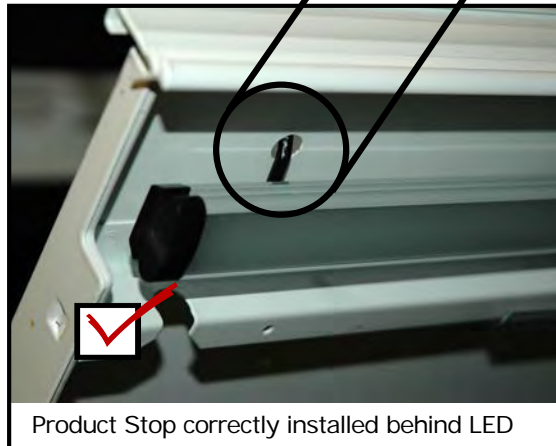

INSTALLING FDA/NSF REQUIRED THERMOMETER

The following pages provide the same information that ships with the thermometer. This requirement does not apply to display refrigerators intended for bulk produce (refer to Page 1-1 for definitions. Please note that the tape cannot be exposed after installation. A digital thermometer may be ordered as an optional kit. Suggested mounting locations for EGP cases is on the interior end panel in a location where the temperature can easily be seen.

This is an NSF-7 &
US FDA Food Code
Required
Thermometer

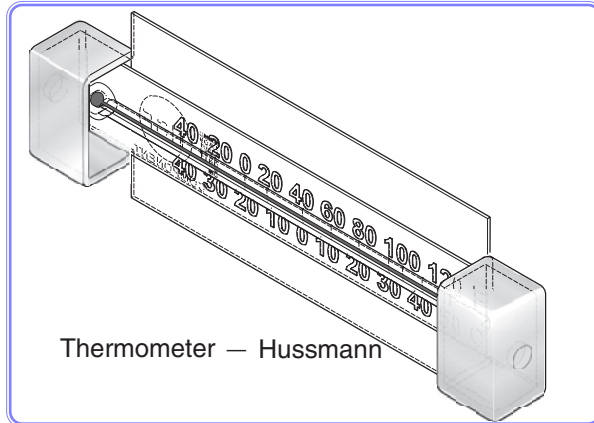

SAFETY INSTRUCTIONS

- » Merchandiser must operate for 24 hours before loading product!
- » Regularly check merchandiser temperatures. Do not break the cold chain. Keep products in freezer before loading into merchandiser.
- » Medium temperature merchandisers are designed for loading ONLY pre-chilled products. Low temperature merchandisers are designed for loading ONLY frozen products.

Important – Please read!

This thermometer is provided in response to United States
Food and Drug Administration (US FDA) Food Code [<http://www.fda.gov/>]
and
National Sanitation Foundation (NSF / ANSI) Standard 7 [<http://www.nsf.org/>]

Each installation will be different depending on how the unit is stocked, shopping patterns in the department and ambient conditions of the store. The suggested locations provided herein are possible locations. It is the responsibility of the purchaser / user to determine the location within the food storage area of the unit that best meets the code requirements above.

The thermometer may need to be moved several times to find the warmest location. Mounting options include flexible plastic for price tag molding application, magnet applied to back of flexible plastic for steel end wall, and double stick tape. Tape must not be exposed after installation.

Questions about either code should be addressed to local agencies or other appropriate officials.

**Keep with merchandiser
or give to store manager.**

DO NOT DESTROY.

MAINTENANCE AND SERVICE

SAFETY CHECKS

WARNING

- Repair and maintenance to electrical components shall include initial safety checks and component inspection procedures. If a fault exists that could compromise safety, then no electrical supply shall be connected to the circuit until it is satisfactorily dealt with. If the fault cannot be corrected immediately but it is necessary to continue operation, an adequate temporary solution shall be used. This shall be reported to the owner of the equipment, so all parties are advised. Initial safety checks shall include:
 - i. Ensure that capacitors are discharged—this shall be done in a safe manner to avoid the possibility of sparking.
 - ii. Ensure that no live electrical components and wiring are exposed while charging, recovering, or purging the system.
 - iii. Ensure that there is continuity of earth bonding.
- Do not apply any permanent inductive or capacitance loads to the circuit without ensuring that this will not exceed the permissible voltage and current permitted for the equipment in use.
- LOCK OUT / TAG OUT — To avoid serious injury or death from electrical shock, always disconnect the electrical power at the main disconnect when servicing or replacing any electrical component. This includes, but is not limited to, such items as doors, lights, fans, heaters, and thermostats.
- Check that cabling will not be subject to wear, corrosion, excessive pressure, vibration, sharp edges, or any other adverse environmental effects. The check shall also take into account the effects of aging or continual vibration from sources such as compressors or fans.
- Refrigerating pipe or components are installed in a position where they are unlikely to be exposed to any substance which may corrode refrigerant containing components, unless the components are constructed of materials which are inherently resistant to being corroded or are suitably protected against being so corroded.
- To reduce the risk of fire, electrical shock or injury when cleaning this merchandiser:
 - Unplug the merchandiser before cleaning
 - Keep all liquids away from electrical and electronic components.

BEFORE WORKING WITH REFRIGERANT

Safety Checks

- Prior to beginning work on systems containing FLAMMABLE REFRIGERANTS, safety checks are necessary to ensure that the risk of ignition is minimized.
- Work shall be undertaken under a controlled procedure so as to minimize the risk of a flammable gas or vapor being present while the work is being performed.
- All maintenance staff and others working in the local area shall be instructed on the nature of work being carried out. Work in confined spaces shall be avoided.
- The area shall be checked with an appropriate refrigerant detector prior to and during work, to ensure the technician is aware of potentially toxic or flammable atmospheres. Ensure that the leak detection equipment being used is suitable for use with all applicable refrigerants, i.e., non-sparking, adequately sealed, or intrinsically safe.
- If any hot work is to be conducted on the refrigerating equipment or any associated parts, appropriate fire extinguishing equipment shall be available on hand. A dry chemical or CO₂ fire extinguisher should be adjacent to the charging area.
- No person carrying out work in relation to a REFRIGERATING SYSTEM which involves exposing any pipe work shall use any sources of ignition in such a manner that it may lead to the risk of fire or explosion. All possible ignition sources, including cigarette smoking, should be kept sufficiently far away from the site of installation, repairing, removing and disposal, during which refrigerant can possibly be released to the surrounding space. Prior to work taking place, the area around the equipment shall be surveyed to make sure that there are no flammable hazards or ignition risks. "No Smoking" signs shall be displayed.
- Ensure that the area is in the open or that it is adequately ventilated before breaking into the system or conducting any hot work. A degree of ventilation shall continue during the period that the work is carried out. The ventilation should safely disperse any released refrigerant and preferably expel it externally into the atmosphere.
- Where electrical components are being changed, they shall be fit for the purpose and to the correct specification. At all times, the manufacturer's maintenance and service guidelines shall be followed. If in doubt, consult the manufacturer's technical department for assistance.
- The following checks shall be applied to installations using FLAMMABLE REFRIGERANTS:
 - a. The actual REFRIGERANT CHARGE is in accordance with the room size within which the refrigerant containing parts are installed;
 - b. The ventilation machinery and outlets are operating adequately and are not obstructed;
 - c. If an indirect refrigerating circuit is being used, the secondary circuit shall be checked for the presence of refrigerant;
 - d. Marking to the equipment continues to be visible and legible. Markings and signs that are illegible shall be corrected;
 - e. Refrigerating pipe or components are installed in a position where they are unlikely to be exposed to any substance which may corrode refrigerant containing components, unless the components are constructed of materials which are inherently resistant to being corroded or are suitably protected against being so corroded.

Checks and Repairs to Electrical Devices

Repair and maintenance to electrical components shall include initial safety checks and component inspection procedures. If a fault exists that could compromise safety, then no electrical supply shall be connected to the circuit until it is satisfactorily dealt with. If the fault cannot be corrected immediately but it is necessary to continue operation, an adequate temporary solution shall be used. This shall be reported to the owner of the equipment, so all parties are advised.

Initial safety checks shall include:

- a. That capacitors are discharged: this shall be done in a safe manner to avoid possibility of sparking;
- b. That no live electrical components and wiring are exposed while charging, recovering or purging the system;
- c. That there is continuity of earth bonding.



- LOCK OUT / TAG OUT — To avoid serious injury or death from electrical shock, always disconnect the electrical power at the main disconnect when servicing or replacing any electrical component. This includes, but is not limited to, such items as doors, lights, fans, heaters, and thermostats.
- To reduce the risk of fire, electrical shock or injury when cleaning this merchandiser:
 - Unplug the merchandiser before cleaning.
 - Keep all liquids away from electrical and electronic components.
- To avoid serious injury or death from electrical shock, always disconnect the electrical power at the main disconnect when servicing or replacing any electrical component. This includes, but is not limited to, such items as doors, lights, fans, heaters, and thermostats.
- Particular attention shall be paid to the following to ensure that by working on electrical components, the casing is not altered in such a way that the level of protection is affected. This shall include damage to cables, excessive number of connections, terminals not made to original specification, damage to seals, incorrect fitting of glands, etc.

- Ensure that the apparatus is mounted securely.
- Ensure that seals or sealing materials have not degraded to the point that they no longer serve the purpose of preventing the ingress of flammable atmospheres. Replacement parts shall be in accordance with the manufacturer's specifications.
- Where electrical components are being changed, they shall be fit for the purpose and to the correct specification. At all times, the manufacturer's maintenance and service guidelines shall be followed. If in doubt, consult the manufacturer's technical department for assistance.
- When servicing, ensure that seals or sealing materials have not degraded to the point that they no longer serve the purpose of preventing the ingress of flammable atmospheres.
- During repairs to sealed components, all electrical supplies shall be disconnected from the equipment being worked upon prior to any removal of sealed covers, etc. If it is absolutely necessary to have an electrical supply to equipment during servicing, then a permanently operating form of leak detection shall be located at the most critical point to warn of a potentially hazardous situation.
- Component parts are designed for propane and are non-incendive and non-sparking. Component parts shall be replaced with like components, and servicing shall be done by factory authorized service personnel only, so as to minimize the risk of possible ignition due to incorrect parts or improper service.
- Do not apply any permanent inductive or capacitance loads to the circuit without ensuring that this will not exceed the permissible voltage and current permitted for the equipment in use.
- Intrinsically safe components are the only types that can be worked on while live in the presence of a flammable atmosphere. The test apparatus shall be at the correct rating.
- Replace components only with parts specified by the manufacturer. Other parts can result in the ignition of refrigerant in the atmosphere from a leak.

CARE AND CLEANING

Long life and satisfactory performance of any equipment is dependent upon the care it receives. To ensure long life, proper sanitation and minimum maintenance costs, these merchandisers should be thoroughly cleaned, all debris removed and the interiors washed down as part of a regular store sanitation schedule.

Fan Plenum

To facilitate cleaning, the fan plenum is hinged. After cleaning be sure the plenum is properly lowered into position or product loss will result due to improper refrigeration.

Fan motor harness plug must be securely connected. Do not disconnect fan motor harness plug for cleaning or maintenance procedures.

To lift the fan plenum:

1. Gently bend the bottom of the hinge pin arm away from the plenum to release the retainer from the coil support.
2. Rotate the hinge pin 180° so that the arm is pointed upwards.
3. Slide the hinge pin out and away from the plenum.



Lift up Fan Plenum. Use chain to hook up fan plenum to facilitate cleaning.

The plenum can also be removed, but this is not necessary for routine cleaning.

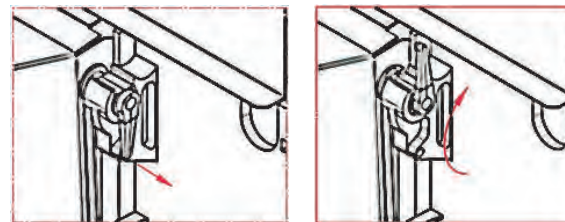

1. Flip the arm up and pull arm out to release the plenum.

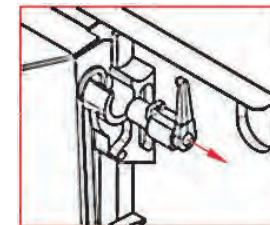

Removable Return Air Grilles

The return air grilles may be removed to facilitate cleaning. Lift a four foot section up and out as shown below.



⚠ WARNING

- » All case cleaning and maintenance procedures should be performed with the power disconnected at the breaker.

IDENTIFICATION OF CASE PARTS

⚠ WARNING

» Do NOT allow cleaning agent or cloth to contact food product.

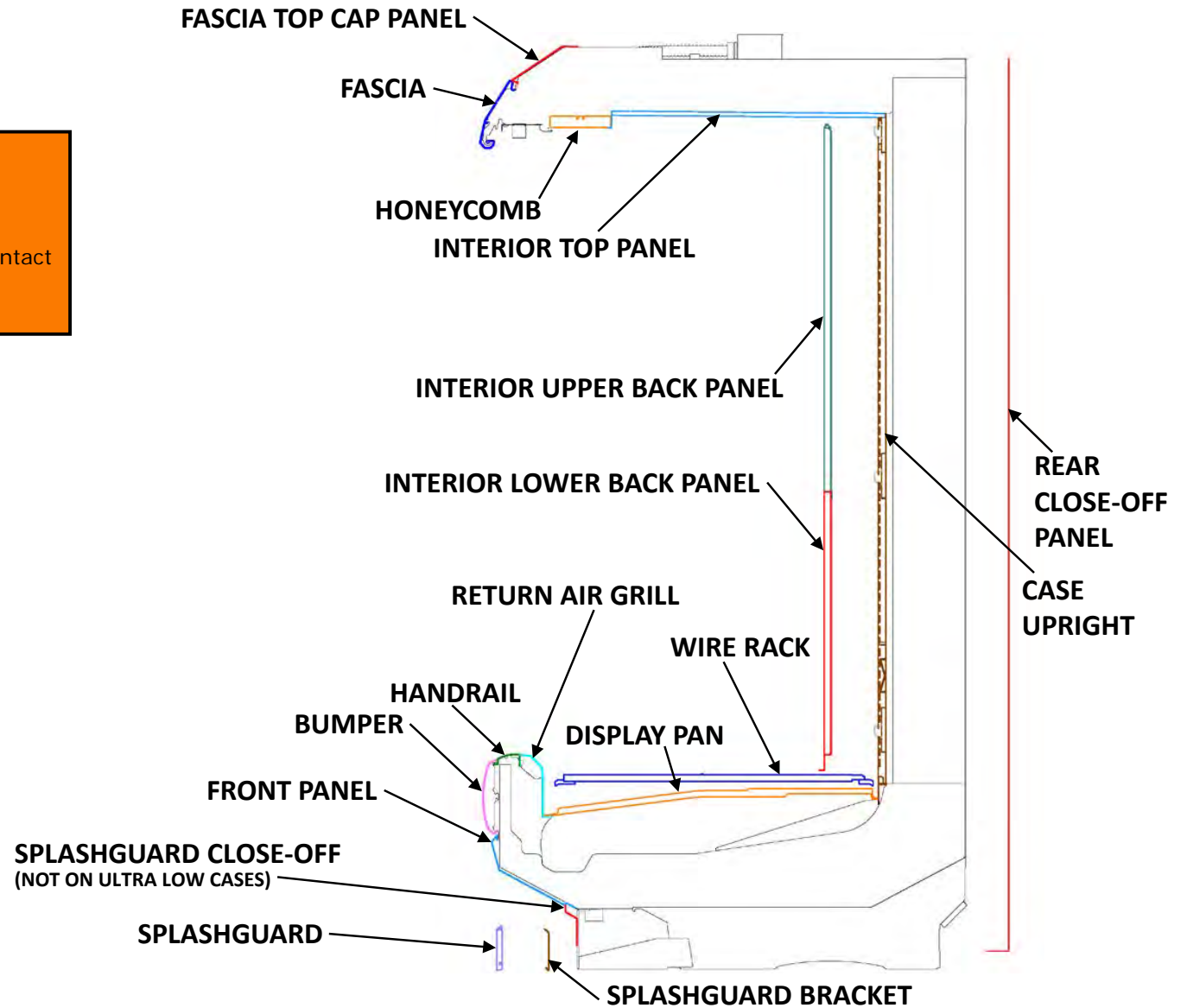

Fascia Panels

The exterior of the fascia panels should be cleaned with a mild detergent and warm water.

Do not use ammonia-based products to clean optional acrylic panels. Never use abrasive cleansers or scouring pads.

EXTERIOR SURFACES

The exterior surfaces must be cleaned with a mild detergent and warm water to protect and maintain their attractive finish.

Never use abrasive cleaners or scouring pads.

INTERIOR SURFACES

The interior surfaces may be cleaned with most domestic detergents, ammonia based cleaners and sanitizing solutions will not harm the surface. Always read and follow the manufacturer's instructions when using any cleaning product.

Inspect all LED connections and plug/ receptacles for signs of arcing. Replace any component that shows signs of arcing. Make sure all unused receptacles have close-off covers securely attached.

Do Not:

- Abrasive cleansers and scouring pads, as these will mar the finish.
- Coarse paper towels on coated glass.
- Ammonia-based cleaners on acrylic parts.
- Do not spray water from a hose directly on the canopy lights or fans.
- Solvent, oil or acidic based cleaners on any interior surfaces.
- A pressure nozzle on canopy lights, shelf lights or any other electrical connection.
- Do not use water pressure beyond what is supplied from the potable water system and spray nozzle (ie Do not use a pressure washer.)

Steps:

- First turn off refrigeration, then disconnect electrical power. Turn off case power at breaker. Make sure all unused light receptacles have their close-off covers securely attached.
- Remove the product and all loose debris to avoid clogging the waste outlet.
- Store product in a refrigerated area such as a cooler. Remove only as much product as can be taken to the cooler in a timely manner.
- Thoroughly clean all surfaces with soap and warm water. Do not use steam or high water pressure hoses to wash the interior. These will destroy the merchandisers' sealing causing leaks and poor performance.
- Lift hinged fan plenum for cleaning. Hook chain in rear panel to secure plenum during cleaning. Be sure to reposition the fan plenum after cleaning merchandiser.
- Take care to minimize direct contact between fan motors and cleaning or rinse water.
- Rinse with warm water, but do not flood. Never introduce water faster than the waste outlet can remove it.
- Allow merchandisers to dry before resuming operation.
- Wipe down lighted shelves with a damp sponge or cloth so that water does not enter the light channel.
- After cleaning is completed, turn on power to the merchandiser.

WARNING

- » Do not use mechanical devices or other means to accelerate the defrosting process.
- » Do not use electrical appliances inside the food storage compartments of the case(s).

RECOMMENDED CLEANING INSTRUCTIONS

The directions below are recommended cleaning instructions for Insight cases and should not be used as a substitute for the store's regular maintenance schedule. Follow all local and national health codes. Cleanliness of the case encourages long-lasting life of the equipment. This guide lists some of the key areas of the cases that require cleaning to help maintain the overall appearance and performance of the equipment and keep it free of debris. The cases may need additional cleaning, especially in high traffic areas, dusty areas and during unusually extended periods of use of the equipment.

Cleaning Instructions Weekly or Monthly

1. Remove product; store it in another case or suitable walk-in cooler.
2. Remove wire racks and bottom pans. Cleaning them in the case with warm water and a soap solution, then rinse and set aside.
3. Turn off case power at breaker.
4. Flip up the fan plenum assembly to provide more room for cleaning in the case if necessary.
5. Remove all loose debris and food particles that may clog drain. Check drain to make sure it is not clogged. Do not force items down drain, use the drain catch to remove debris and dispose.
6. Remove honeycomb and price display molding.
7. Clean all surfaces including shelves and honeycomb by spraying down water (preferably warm) and mild detergent. Use a brush or cleaner pad if necessary to aid in penetrating dirt.
8. Rinse all surfaces with water, then spray with a sanitizer. Rinse off sanitizer with clean water using a hose. Allow surfaces to air dry, since wiping would defeat the purpose of sanitizing.
9. Replace all internal parts carefully so that they seat properly. This is necessary for proper case operation.
10. Turn ON power to the fans at breaker.
11. Replace product.

Cleaning Instructions Quarterly or Semiannually

1. Remove product; store it in another case or suitable walk-in cooler.
2. Remove wire racks and bottom pans. Cleaning them in the case with warm water and a soap solution, then rinse and set aside.
3. Turn off case power at breaker.
4. Flip up the fan plenum assembly to provide more room for cleaning in the case if necessary.
5. Remove all loose debris and food particles that may clog drain. Check drain to make sure it is not clogged. Do not force items down drain, use the drain catch to remove debris and dispose.
6. Remove honeycomb and price display moulding.
7. Clean all surfaces including shelves and honeycomb by spraying down water (preferably warm) and mild detergent. Use a brush or cleaner pad if necessary to aid in penetrating dirt.
8. Remove all the shelves and set aside then remove the back panels.
9. Clean the backside of the back panels in the case as you remove them.
10. Clean the newly exposed surfaces and the coil by spraying down with water (preferably warm) and a mild detergent solution.
11. Rinse the newly exposed surfaces and the coil with water then spray with a sanitizer. Allow surfaces to air-dry, since wiping would defeat the purpose of sanitizing.
12. Replace the back panels and shelves.
13. Rinse all surfaces with water, then spray with a sanitizer. Allow surfaces to air-dry since wiping would defeat the purpose of sanitizing.
13. Replace all remaining internal parts carefully so that they seat properly. This is necessary for proper case operation.
14. Turn ON power to the fans at breaker.
15. Replace product.

CLEANING HONEYCOMB ASSEMBLIES

Honeycombs should be cleaned every six months, or depending on store environment the honeycombs may need to be cleaned more often. Dirty honeycombs will cause cases to perform poorly.

The honeycombs may be cleaned with a vacuum cleaner. Soap and water may be used if all water is removed from the honeycomb cells before replacing. Be careful not to damage the honeycombs.

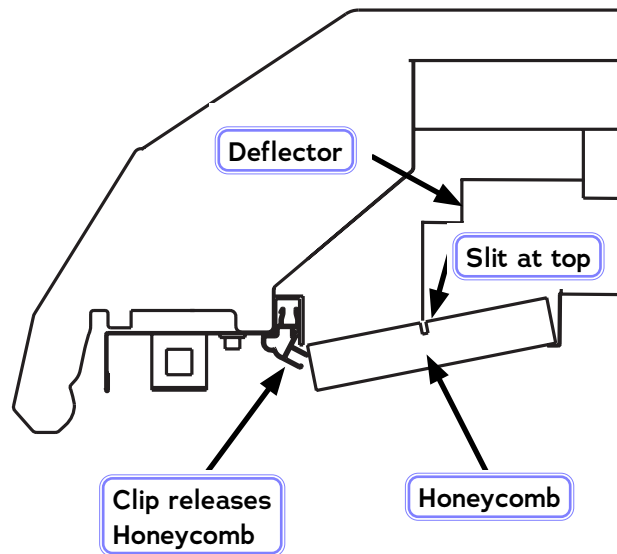

1. Remove honeycomb by pulling clip as shown above.
2. Clean and dry the honeycomb.
3. Honeycomb is symmetrical.
4. After cleaning, replace honeycomb. Ensure clip is centered and engaged along full-length of honeycomb.

Damaged honeycomb must be replaced.

CLEANING MIRRORS

Mirrors are sheets of clear glass that have very thin reflective and protective coatings applied to one side. These coatings are susceptible to deterioration if certain cleaning solutions and even water are allowed to come in contact with them. Every precaution should be taken to keep all liquids away from the coated side of the mirrors. If liquids are allowed to flow along the face side of the mirror to its edge, the liquid can seep up between the coating and the glass, causing serious damage.

To Help Prolong the Life of the Mirrors:

- Use only mild cleaning solutions that do not leave residue, such as a weak (10%) solution of vinegar and water.
- Do not spray liquids on the mirrors. Away from food, dampen the cleaning cloth, then use the cloth to wipe the mirror.
- Wipe water from the mirrors immediately to prevent difficult to remove water spots and also to prevent the water from reaching the mirror's edge.
- Never use dirty cloths, scrapers or any other abrasive materials for cleaning.

⚠ WARNING

- » Product will be degraded and may spoil if allowed to sit in a non-refrigerated area.
- » All products in the case should be removed and stored in a cooler at the appropriate temperature before cleaning the interior of the case.

REMOVING INTERIOR BACK PANELS

The interior back panels may be removed for cleaning and to gain access to the evaporator coils. Remove the rear interior back panels as follows:

1. Disconnect the electrical power to the merchandiser.
2. Unplug shelf lights and insert plastic protective cap. Remove shelving.
3. Remove the lower panel first: lift the panel up, then pull forward and out.
4. Remove the top panel.



5. Replace panels in reverse order, starting with the top panel.

BOTTOM LINER REPAIR

Insight merchandisers have bottom liners, which are made of a high density polyethylene material (HDPE). Repairs may be made if the bottom liner becomes damaged. Follow the illustrations at right to repair the liner.

For minor repairs:

Minor repairs consist of deep scratches and tears that are no more than 1/8 inch thick.

1. Remove all product, and disconnect power to the case that is to be serviced. Locate the damaged area of the liner. Clear and clean the area, then wipe it dry.
2. Use an electric hot air gun to heat the tear. Heat to 600°F (316°C). Solder the tear with 1/8 inch filler welding rod, made from HDPE. Ensure no voids or skips in completed bead.
3. Let the area cool, then buff the area flat. A 5-inch, 80 grit disc works well for this. The repair is now complete.



Forthoff Mini Electric Hot Air Gun
(120V 1300W)

For major repairs:

1. For repairs with larger size gashes or holes, a piece of HDPE may be cut into a square as shown in (F) at right. (The square HDPE shown in the photo is white for clarity.)
2. Remove all product and disconnect power to the case that is to be serviced. Locate the damaged area of the liner. Clear and clean the area, then wipe it dry. Ensure no voids or skips in completed bead.
3. The square is then tacked at all four corners using the hot air gun.
4. Solder with 1/8 inch filler welding rod around the perimeter of the HDPE square.
5. Buff the area flat if needed. The repair is now complete.

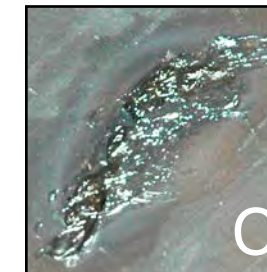
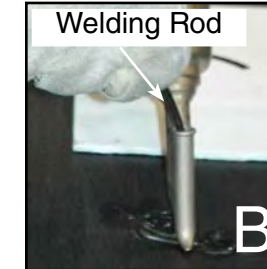
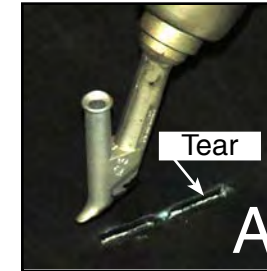

⚠ WARNING

- » Always wear protective clothing when operating hot air gun, such as fire resistant gloves and arm guards. Hot air gun operates at extremely high temperature and could cause serious burns. Always have fire protective gear on hand in case of fire.
- » To avoid serious injury or death from electrical shock, always disconnect the electrical power at the breaker when servicing or replacing any electrical component. This includes, but is not limited to, such items as doors, lights, fans, heaters, and thermostats.

CLEANING UNDER MERCHANDISERS

Remove splashguards not sealed to floor. Use a vacuum with a long wand attachment to remove accumulated dust and debris from under the merchandiser.

CLEANING COILS

Never use sharp objects around coils!

Use a soft brush or vacuum brush to clean debris from coils. Do not puncture coils! Do not bend fins. Contact an authorized service technician if a coil is punctured, cracked or otherwise damaged.

ICE in or on the coil indicates the refrigeration and defrost cycle is not operating properly. Contact an authorized service technician to determine the cause of icing, and to make adjustments as necessary. To maintain product integrity, move all product to a cooler until the unit has returned to normal operating temperatures.

- Do not puncture coils!
- Do not bend fins. Contact an authorized service technician if a coil is punctured, cracked, or otherwise damaged.
- Do NOT use chlorine or ammonia-based cleaners to clean aluminum coils.

CLEANING STAINLESS STEEL FRONT RAILS

Use non-abrasive tools, and always polish with grain of the steel. Use alkaline chlorinated or non-chlorine containing cleaners. Do not use cleaners containing salts as this may cause pitting and rusting of the stainless steel finish.

Clean frequently to avoid build-up of hard, stubborn stains. Rinse and wipe dry immediately after cleaning. Never use hydrochloric acid (muriatic acid) on stainless steel.

REMOVING SCRATCHES FROM BUMPER

Most scratches and dings can be removed using the following procedure.

- Use steel wool to smooth out the surface area of the bumper.
- Clean area.
- Apply vinyl or car wax and polish surface for a smooth glossy finish.

WARNING

- » Do not use HOT water on COLD glass surfaces. This can cause the glass to shatter and could result in personal injury. Allow glass fronts, ends and service doors to warm before applying hot water.

SERVICE

TROUBLESHOOTING

Problem	Possible Cause	Possible Solution
Case temperature is too warm.	Ambient conditions may be affecting the case operation.	Check case position in store. Is the case located near an open door, window, electric fan or air conditioning vent that may cause air currents? Case must be located minimum 15 ft away from doors or windows. Cases are designed to operate at 55% Relative humidity and a temperature of 75°F.
	Discharge air temp is out of spec.	Check evaporator fan operation. Check electrical connections and input voltage.
		Fans are installed backwards. Check airflow direction.
		Make sure fan blades have correct pitch and are per specification.
		Check to see that fan plenum is installed correctly. It should not have any gaps.
		Check suction pressure and ensure that it meets factory specifications.
	Case is in defrost.	Check defrost settings. See Technical Data Sheet.
	Product is outside of the load limit area, blocking airflow.	Redistribute product so it does not exceed load limit. There is a sticker on the inside of the case indicating the maximum load limit.
Coil is freezing over.	Return air is blocked, make sure debris is not blocking the intake section.	
	Coil close-offs are not installed. Inspect coil to make sure these parts are on the case.	
	Clean coil.	
Condensing coil or evaporator coil is clogged or dirty.		
Case temperature is too cold.	The t-stat temp is set too low.	Check settings. See Technical Specifications on the data sheet.
	Ambient conditions may be affecting the case operation.	Check case position in store. Is the case located near an open door, window, electric fan or air conditioning vent that may cause air currents? Case must be located minimum 15 ft away from doors or windows. Cases are designed to operate at 55% Relative humidity and a temperature of 75°F.

TROUBLESHOOTING CONTINUED

Problem	Possible Cause	Possible Solution
Water has pooled under case.	Case drain is clogged.	Clear drain.
	PVC drains under case may have a leak.	Repair as needed.
	Case tub has unsealed opening.	Seal as needed.
	If the case is in a line-up, case to case joint is missing or unsealed.	Install case to case joint and seal as needed.
	Evaporator pan is overflowing (if applicable).	Check electrical connection to evaporator pan. Check float assembly, it should move freely up and down the support stem. Clear any debris.
	Case is not level.	Level the case.
	Drain screen is plugged.	Clean drain screen and remove any debris.
Case is not draining properly.	Drain or P-trap is clogged.	Clear any debris.
Frost or ice on evaporator coil.	Evaporator fans are not functioning.	Check electrical connections.
	Defrost clock is not functioning.	Case should be serviced by a qualified service technician.
	Coil is freezing over.	Return air is blocked, make sure debris is not blocking the intake section. Coil close-offs are not installed. Inspect coil to make sure these parts are on the case.
Lights do not come on.	LED Driver / light socket wiring.	Check electrical connections. See Electrical Section and check wiring diagram.
	LED Driver needs to be replaced.	Case should be serviced by a qualified service technician. See Electrical Section.
	LED fixture socket / connection needs to be replaced.	Case should be serviced by a qualified service technician.
	LED fixture needs to be replaced.	See Maintenance Section.
	Light Switch needs to be replaced.	Case should be serviced by a qualified service technician.

REFRIGERANT REMOVAL, EVACUATION AND RECOVERY

When breaking into the refrigerant circuit to make repairs—or for any other purpose—conventional procedures shall be used. However, for flammable refrigerants it is important that best practice be followed, since flammability is a consideration. The following procedure shall be adhered to:

- a. Safely remove refrigerant following local and national regulations;
- b. Purge the circuit with inert gas;
- c. Evacuate;
- d. Purge with inert gas;
- e. Open the circuit by cutting or brazing.

The refrigerant charge shall be recovered into the correct recovery cylinders if venting is not allowed by local and national codes. The system shall be purged with oxygen-free nitrogen to render the appliance safe for flammable refrigerants. This process might need to be repeated several times. Compressed air or oxygen shall not be used for purging refrigerant systems.

Refrigerants purging shall be achieved by breaking the vacuum in the system with oxygen-free nitrogen and continuing to fill until the working pressure is achieved, then venting to atmosphere, and finally pulling down to a vacuum. This process shall be repeated until no refrigerant is within the system. When the final oxygen-free nitrogen charge is used, the system shall be vented down to atmospheric pressure to enable work to take place.

Ensure that the outlet for the vacuum pump is not close to any potential ignition sources and that ventilation is available.

RECOVERY PROCEDURE

When removing refrigerant from a system, either for servicing or decommissioning, it is recommended good practice that all refrigerants are removed safely. When transferring refrigerant into cylinders, ensure that only appropriate refrigerant recovery cylinders are employed. Ensure that the correct number of cylinders for holding the total system charge is available.

All cylinders to be used are designated for the recovered refrigerant

and labeled for that refrigerant (i.e., special cylinders for the recovery of refrigerant). Cylinders shall be complete with pressure-relief valve and associated shut-off valves in good working order. Empty recovery cylinders are evacuated and, if possible, cooled before recovery occurs.

The recovery equipment shall be in good working order with a set of instructions concerning the equipment that is at hand and shall be suitable for the recovery of all appropriate refrigerants including, when applicable, FLAMMABLE REFRIGERANTS. In addition, a set of calibrated weighing scales shall be available and in good working order. Hoses shall be complete with leak-free disconnect couplings and in good condition. Before using the recovery machine, check that it is in satisfactory working order, has been properly maintained and that any associated electrical components are sealed to prevent ignition in the event of a refrigerant release. Consult manufacturer if in doubt.

The recovered refrigerant shall be returned to the refrigerant supplier in the correct recovery cylinder, and the relevant waste transfer note arranged. Do not mix refrigerants in recovery units and especially not in cylinders.

If compressors or compressor oils are to be removed, ensure that they have been evacuated to an acceptable level to make certain that FLAMMABLE REFRIGERANT does not remain within the lubricant. The evacuation process shall be carried out prior to returning the compressor to the supplier. Only electric heating to the compressor body shall be employed to accelerate this process. When oil is drained from a system, it shall be carried out safely.

REFRIGERANT CHARGING PROCEDURE

A calibrated scale with +/-2 gram accuracy must be used to charge the system. The charge amount is shown on the serial plate.

No gas charge adjustments are allowed. When connecting hoses between the refrigeration system, manifold gauges, and refrigerant cylinder, ensure that the connections are secure and there are no potential sources of ignition nearby. Ensure that contamination of different refrigerants does not occur when using charging equipment.

Use dedicated hoses to service refrigeration systems. Hoses or lines should be as short as possible to minimize the amount of refrigerant contained in them.

Ensure that the refrigeration system is properly grounded prior to charging the system with refrigerant, to avoid the potential for static build-up.

In addition to conventional charging procedures, the following requirements shall be followed:

- a. Ensure that contamination of different refrigerants does not occur when using charging equipment. Hoses or lines shall be as short as possible to minimize the amount of refrigerant contained in them.
- b. Cylinders shall be kept in an appropriate position according to the instructions.
- c. Ensure that the REFRIGERATING SYSTEM is earthed prior to charging the system with refrigerant.
- d. Label the system when charging is complete (if not already).
- e. Extreme care shall be taken not to overfill the REFRIGERATING SYSTEM.

Prior to recharging the system, it shall be pressure-tested with the appropriate purging gas. The system shall be leak-tested on completion of charging but prior to commissioning. A follow up leak test shall be carried out prior to leaving the site.

Extreme care must be taken not to overfill the refrigeration system. After charging, carefully disconnect the hoses, attempting to minimize the quantity of refrigerant released. Further leak check the service ports, hoses, refrigerant tanks.

Thoroughly leak check the service ports. If no leak is present, use a pinch-off tool to close the ends of the service tubes before brazing them shut. If a Schrader valve is used on the compressor service tube, it must be removed and the previous steps followed in order to braze the service tube shut.

REPLACING FAN MOTORS

See Appendix for separate fan motor replacement instructions if motor harness connector is different than the one shown below.

Should it ever be necessary to service or replace the fan motors or blades, be certain that the fan blades are reinstalled correctly.

To access and replace fan motor:

1. Turn off case power at breaker.
2. Remove bottom display pans.
3. Unpack new motor/harness assembly and set aside outside of case.
4. Remove screws holding existing fan motor bracket assembly to plenum, and remove assembly from plenum.
5. Disengage and unplug existing motor harness connector; remove existing motor.
 - A. Grasp the plug and receptacle, and apply slight pressure to pull apart. The connector should not separate without depressing the locking tab.



Locking Tab



6. Taking care to avoid any existing moisture in the case, IMMEDIATELY connect and lock new motor harness as follows:
 - A. Align the plug and receptacle, and push together until the locking tab engages. (Locking tab must engage in the window of receptacle and not separate.)



Locking Tab

Window

⚠ WARNING

— LOCK OUT / TAG OUT —

- » To avoid serious injury or death from electrical shock, always disconnect the electrical power at the main disconnect when servicing or replacing any electrical component. This includes, but is not limited to, such items as doors, lights, fans, heaters, and thermostats.
- » Warning: Before obtaining access to terminals, all supply circuits must be disconnected.

7. Place new fan motor assembly back into plenum, and reinstall screws to secure.
8. Turn on power.
9. Verify that motor is working and blade is turning in the correct direction.
10. Close air gaps under fan plenum. Warmer air moving into refrigerated air reduces effective cooling. If the plenum does not rest against the case bottom without gaps, apply foam tape to the bottom of the fan plenum to reduce improper air movement. Use silicone sealant to close other gaps.
11. Replace display pans. Bring merchandiser to operating temperature before restocking.



WARNING

STOP - DO NOT UNPLUG

All case cleaning and maintenance procedures should be performed with the power disconnected at the breaker. Failure to adhere to these instructions can lead to damage to the unit and creates the risk of flammability or electrical shock. The fan motor harness plug MUST be properly secured in order to achieve its IP68 rating.

This connection should ONLY be disconnected / connected by a qualified contractor and ONLY in the event of fan motor replacement. The fan motor harness should not be disconnected / connected in performing any other cleaning, service, or repair. Refer to the installation, operation and services manual for sequence of repair.

REPLACING DOOR HANDLES

These doors have glued on studs. If the handle is broken it should be replaced along with the stud.

1. Use a razor blade to remove the excess glue from the door. Only replace the stud that is damaged.
2. Clean the glass surface. Apply isopropyl alcohol to the surface of the glass and wipe using a paper towel until dry.
3. Clean the surface of the stud. Apply isopropyl alcohol to the surface to the stud and wipe using a paper towel until dry.
4. Apply Loctite SF 7387 to the bottom flat surface of the stud and wait 30 seconds or until dry.



Tools and Supplies Needed:

EcoVision Stud: P/N [3119359](#)

Glue: Loctite AA 392

Activator: Loctite SF 7387

Razor

Hammer, if needed

Template

Isopropyl Alcohol

Paper Towels

Tape

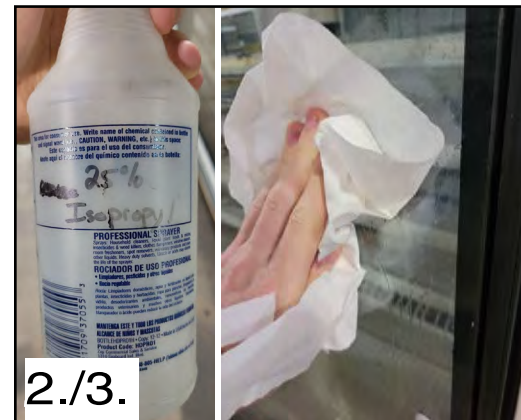

5. Place the stud template in the correct orientation/location and secure to surface of the door. Ensure tape does not leave residue when removed. Painter's tape and 3M 8898 are the suggested choice of tape to use.
6. Apply a drop of Loctite AA 392 to the center of the stud.
7. By hand, firmly press the stud to the glass for 15 seconds.



8. Carefully remove the stud template from the door and wait 5 minutes to allow the glue to cure fully.
9. Carefully wipe away any excess glue / activator from glass surface and clean using isopropyl alcohol.

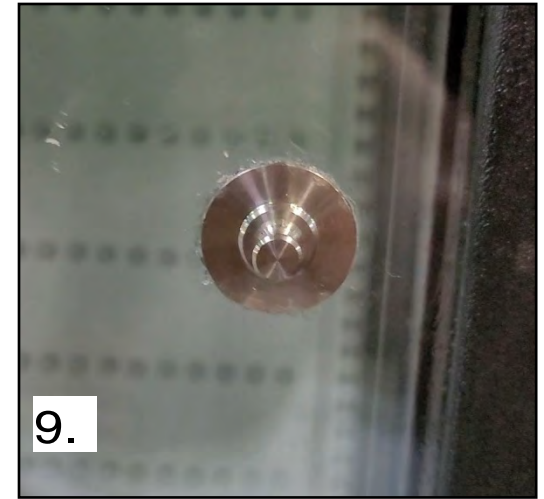

REPLACING ALUMINUM COIL

The aluminum coils used in Hussmann merchandisers may be easily repaired in the field. Materials are available from local refrigeration wholesalers.

Hussmann recommends the following technique:

1. Locate Leak.
2. Remove all pressure.
3. Brush area under heat.
4. Only use a Prestolite torch with number 6 tip.
5. Maintain separate set of stainless steel brushes, and use only on aluminum.
6. Tin surface around area.
7. Brush tinned surface UNDER HEAT, thoroughly filling the open pores around leak.
8. Repair leak. Let aluminum melt solder, NOT the torch.
9. Don't repair for looks. Go for the thickness.
10. Perform a leak check.
11. Wash with water.
12. Cover with a good flexible sealant.

CAUTION

- » When brazing pipes be sure to use an insulation blanket to prevent damage to the plastic case bottom.

DECOMMISSIONING PROCESS

Before carrying out this procedure, it is essential that the technician is completely familiar with the equipment and all its details. It is recommended good practice that all refrigerants are recovered safely. Prior to the task being carried out, an oil and refrigerant sample should be taken in case analysis is required prior to re-use of recovered refrigerant. It is essential that electrical power is available before the task is commenced.

- a. Become familiar with the equipment and its operation.
- b. Isolate the system electrically.
- c. Before attempting the procedure, ensure:
 - i. Mechanical handling equipment is available, if required, for handling refrigerant cylinders.
 - ii. All personal protective equipment is available and being used correctly.
 - iii. The recovery process is supervised at all times by a qualified, competent person.
 - iv. Recovery equipment and cylinders conform to the appropriate standards.
- d. Pump down refrigerant system, if possible.
- e. If a vacuum is not possible, make a manifold so that refrigerant can be removed from various parts of the system.
- f. Make sure that cylinder is situated on the scales before recovery takes place.
- g. Start the recovery machine and operate in accordance with instructions.
- h. Do not overfill cylinders (no more than 80% volume liquid charge).
 - i. Do not exceed the maximum working pressure of the cylinder, even temporarily.
- j. When the cylinders have been filled correctly and the process completed, make sure that the cylinders and the equipment are removed from site promptly and all isolation valves on the equipment are closed off.
- k. Recovered refrigerant shall not be charged into another refrigerating system unless it has been cleaned and checked.

Equipment shall be labeled stating that it has been decommissioned and emptied of refrigerant. The label shall be dated and signed. For appliances containing flammable refrigerants, ensure that there are labels on the equipment stating the equipment contains flammable refrigerant.

APPENDIX

REPLACING FAN MOTORS

(For fan motors with locking harness connector)

Fan control electronics are electrostatic sensitive (ESD). If the case is equipped with an optional fan speed selector (FSS), use a grounding kit before handling. See Page 7-3.

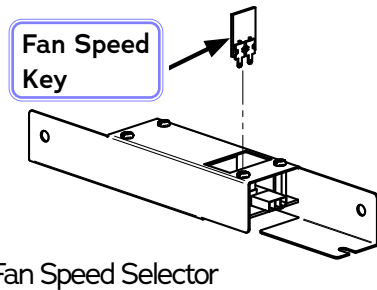

See cross section for location of evaporator fans. Should it ever be necessary to service or replace the fan motors or blades be certain that the fan blades are re-installed correctly.

To access and replace fan motor:



1. Turn off case power at breaker.
2. Remove bottom display pans.
3. Unpack new motor/harness assembly and set aside outside of case.
4. Remove screws holding existing fan motor bracket assembly to plenum, and remove assembly from plenum.
5. Unlock and Unplug existing motor harness from harness; remove existing motor.
 - A. Rotate locking ring counterclockwise to unlock.
 - B. Pull connector straight out to disengage.
6. Taking care to avoid any existing moisture in the case, IMMEDIATELY connect and lock new motor harness as follows:

⚠ WARNING

— LOCK OUT / TAG OUT —

» To avoid serious injury or death from electrical shock, always disconnect the electrical power at the main disconnect when servicing or replacing any electrical component. This includes, but is not limited to, such items as doors, lights, fans, heaters, and thermostats.

Correct connection procedure for main fan motor harness connector:

- A. Align arrows and push connector into position.
- B. Rotate locking ring until all three arrows are aligned in the secured position.

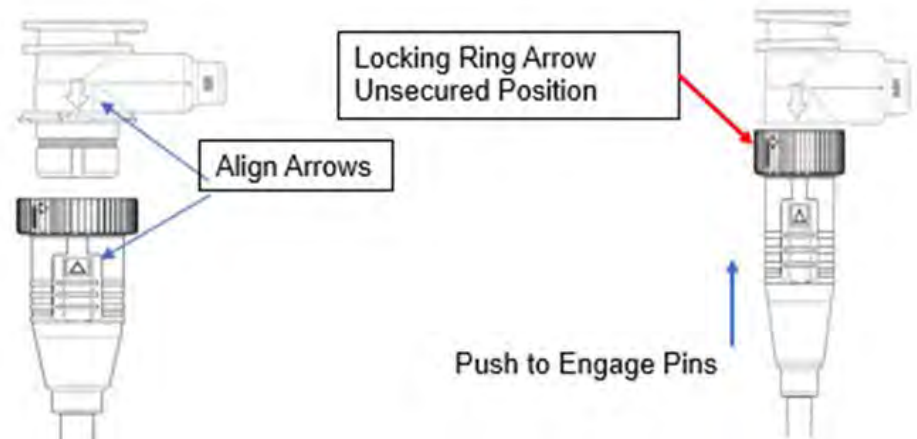

- C. Push straight in to engage pins.
- D. Turn locking ring until all three arrows are aligned.

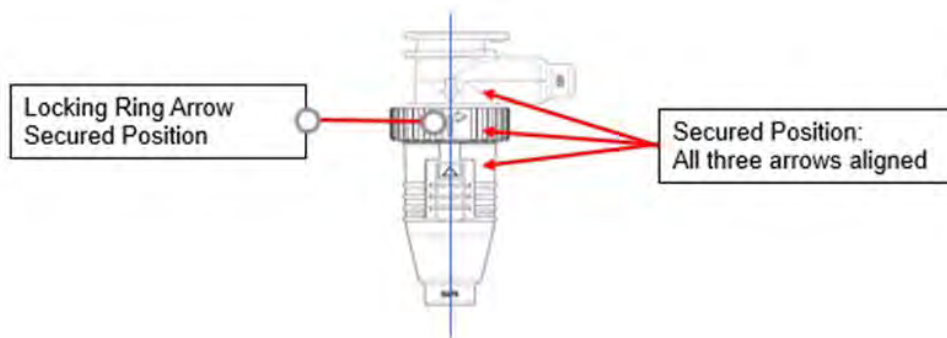

Remember. Push to engage, then twist to secure.

- 7. Place new fan motor assembly back into plenum, and reinstall screws to secure.
- 8. Turn on power.
- 9. Verify that motor is working and blade is turning in the correct direction.
- 10. Close air gaps under fan plenum. Warmer air moving into refrigerated air reduces effective cooling. If the plenum does not rest against the case bottom without gaps, apply foam tape to the bottom of the fan plenum to reduce improper air movement. Use silicone sealant to close other gaps.
- 11. Replace display pans. Bring merchandiser to operating temperature before restocking.

⚠ WARNING

STOP - DO NOT UNPLUG

The fan motor harness plug **MUST** be properly secured in order to perform at its IP67 rating. The component is a twist lock style connector with an alignment arrow to validate a secure connection. This connection should **ONLY** be disconnected / connected by a qualified contractor and **ONLY** in the event of a fan motor replacement. The fan motor harness plug should not be disconnected/connected in performing any other cleaning, service or repair. Refer to the installation, operation and services manual for sequence of repair. All case cleaning & maintenance procedures should be performed with the power disconnected at the breaker. Failure to adhere to these instructions can lead to damage to the unit and creates a risk of flammability.

FAN SPEED SELECTOR

(Handling Electrostatic Sensitive Devices)

For cases manufactured before September 27th, 2023.

Some Insight merchandisers are equipped with a fan speed selector to optimize fan speeds and enhance energy performance. The electronics may be standard or later installed to the cases as a kit. These electronics consist of an input in the motor, and a controller with a key that allows fan speeds to be changed. (Only a professional technician should make any changes to the fan speeds.) A different speed key may need to be ordered to change the fan speed. Contact your Hussmann representative to learn and order what speed key is appropriate for your products.

ESD (electrostatic discharge) sensitive device. Charged devices and circuit boards can discharge without detection. Although this product contains protection circuitry, damage may occur on devices subjected to high energy ESD. Proper precautions should be taken to avoid loss of functionality.

A field grounding kit is recommended for installation of components from a kit or for field service work performed by internal service personnel. The following equipment is recommended for work being performed in the case:



Example of Grounding Kit
3M 8507 with audible alarm

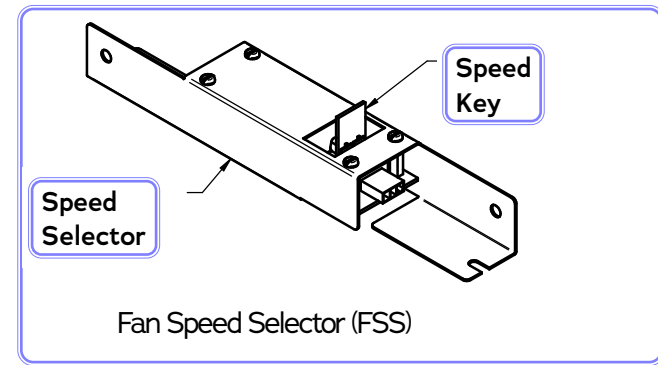

DO:

- Minimize handling.
- Keep parts in original packaging until ready for use.
- Store and carry components in Original Manufacture Packaging or equivalent Static shielding bags.
- Discharge static before handling device by touching nearby grounded surface.
- Handle devices by the body.
- Keep a dust free work area.

DON'T:

- Touch the leads of any device.
- Slide ES Sensitive devices over any surface.
- Store or carry components or assemblies in plastic bags.
- Store sensitive components in thermocole/plastic foam.

Field Ground Kit with instructions for use

Recommended Suppliers/Distributors of Equipment:

DESCO Industries

Part Numbers (18575 or 18576 or 95651)

3M Corporation

Part Numbers (8501 or 8505 or 8507 or FSKL3RD)

Amazon, DigiKey, Grainger, Mouser, Newark. Search under ESD Service Kits.

INSTALLING TYPE II FAN SPEED SELECTOR KIT

A fan speed selector may be required for a merchandiser to operate for certain applications such as Type II conditions. However, if the speed key is removed, the fans will return to the default fan speed, which typically aligns with Type I operation. Each key is configured from the factory to operate for the specific model for which it was ordered.

ANSI/NSF-7 Type II – Display Refrigerator / Freezer Intended for 80°F / 55% RH Ambient Application

Contact your Hussmann representative to order this kit if the cases in your lineup are required to operate in Type II conditions. The selector will operate up to 6 fan motors. Only an experienced electrician should install the fan selector.

1. Mount the selector inside of the raceway of each case. Insert the speed key into the selector. Insert harness connector (2-pin) into the Selector. The 2-pin side supplies power to the selector. It can be used with 110V or 220V circuits.
2. Insert the harness connector (3-pin) into the selector. The 3-pin side sends a signal to the fan motor and the fan speed RPM is now changed to the new setting.

Air curtain fans are shown on the next page.

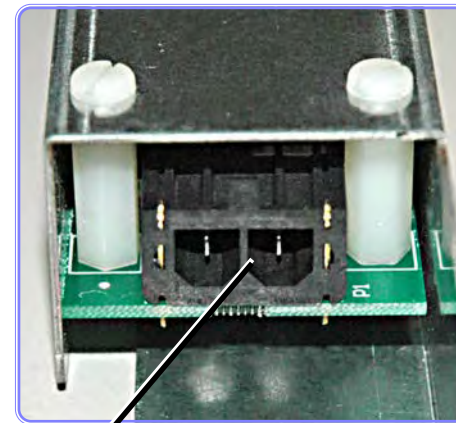

2-Pin Input Line Voltage
to Selector

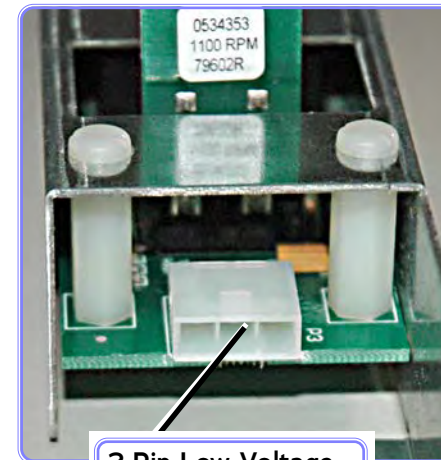

3-Pin Low Voltage
Signal to Fan Motor
(for RPM Speed)

⚠ WARNING

— LOCK OUT / TAG OUT —

- » To avoid serious injury or death from electrical shock, always disconnect the electrical power at the breaker when servicing or replacing any electrical component. This includes, but is not limited to, such items as doors, lights, fans, heaters, and thermostats.

TYPE II FAN SPEED SELECTOR LOCATION

Fan Speed Selector Harness Routing Tall Multi-Deck (when required)

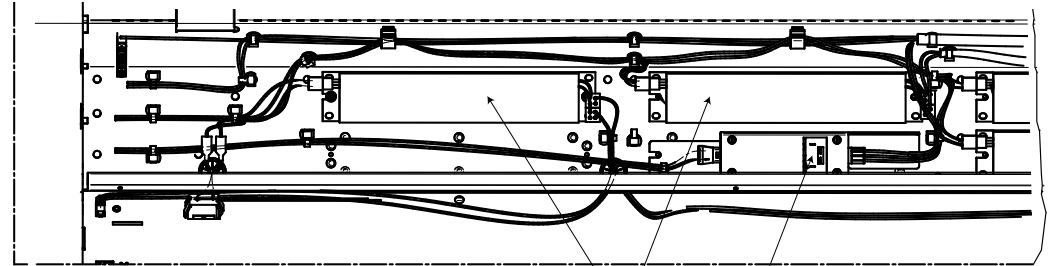

LED Power Fan Speed Selector (FSS)
Supply

Fan Speed Selector Harness Routing Single Deck IC2, IC2X IC3 (when required)

Fan Speed Selector (FSS)

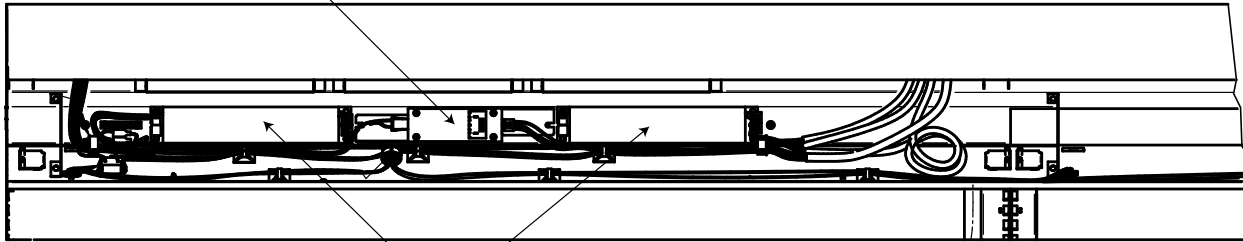

LED Power
Supply

Fan Speed Selector Harness Routing Single Deck IM1-IP1-IC1 (when required)

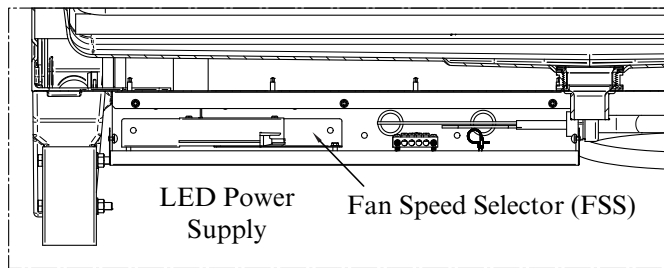

4FT LENGTH

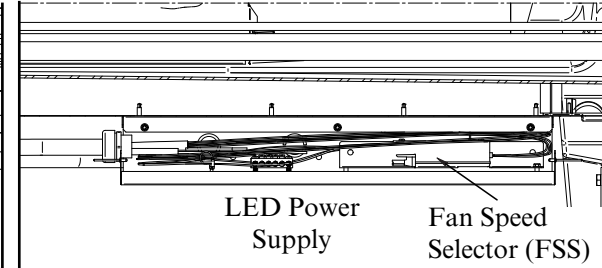

LED Power
Supply Fan Speed
Selector (FSS)

6, 8 & 12FT LENGTHS

WARRANTY

To obtain warranty information or other support, contact your Hussmann representative or visit:

<https://www.hussmann.com/services/warranty>.

Please include the model and serial number of the product.

For questions about your equipment, please contact our Technical Support Team at 1-866-785-8499

For general support or service calls, contact our Customer Support Call Center at 1-800-922-1919

For ordering aftermarket warranty parts, call 1-855-HussPrt (1-855-487-7778) or email the following address:

Hussmann_part_warranty@hussmann.com

REVISION HISTORY

Revision W: Add CO2 high pressure information; modified drain piping assembly, page 3-4; added splashguard assembly for ultra-low front cases, page 3-13

Revision V: Updated for Compliance with UL 60335

Revision U - Added French part number and updated contact information.

Revision T - Updated fan motor instructions; created Appendix

Revision S - manual not used or published



Scan the QR code on your mobile device to access additional product information or order parts.

Parts may also be ordered at:

parts.hussmann.com

Call toll free: 1.855.487.7778

We reserve the right to change or revise specifications and product design in connection with any feature of our products. Such changes do not entitle the buyer to corresponding changes, improvements, additions or replacements for equipment previously sold or shipped.