

Insight®

Single & Multi-Deck

Includes Front Door & Rear-Load Cases



IMPORTANT

Keep in store for future reference!

MEDIUM TEMPERATURE

Installation & Operation Manual

Shipped With Case Data Sheets

P/N 0535974_R

April 2023

Spanish P/N 0535975



BEFORE YOU BEGIN

Read these instructions completely and carefully.



This manual was written in accordance with originally prescribed equipment that is subject to change. Hussmann reserves the right to change or revise specifications and product design in connection with any feature of our products.

PERSONAL PROTECTION EQUIPMENT (PPE)



Only qualified personnel should install and service this equipment. Personal Protection Equipment (PPE) is required whenever servicing this equipment. Wear safety glasses, gloves, protective boots or shoes, long pants, and a long-sleeve shirt when working with this equipment and handling glass. Observe all precautions on tags, stickers, labels and literature attached to this equipment.



This warning does not mean that Hussmann products will cause cancer or reproductive harm, or is in violation of any product-safety standards or requirements. As clarified by the California State government, Proposition 65 can be considered more of a 'right to know' law than a pure product safety law. When used as designed, Hussmann believes that our products are not harmful. We provide the Proposition 65 warning to stay in compliance with California State law. It is your responsibility to provide accurate Proposition 65 warning labels to your customers when necessary. For more information on Proposition 65, please visit the California State government website.

TABLE OF CONTENTS

ANSI Z535.5 DEFINITIONS iv INSIGHT INSTALLATION TOOL LIST iv INSTALLATION UL Listing 1-1 Federal / State Regulations 1-1 Location 1-1 Product Temperatures 1-1 Shipping Damage 1-2 Unloading 1-2 Exterior Loading 1-2 Unloading Using a Pallet Jack 1-3 Optional Casters and Dollies 1-3 Serial Plate Location 1-3 QR Code 1-3 Merchandisers Shipped with End Installed 1-4 End Shipping Braces 1-4 Shipping Rider 1-4 Merchandiser Leveling 1-5 Joining Open Cases in Lineup 1-6 Sealing Lineup Joint 1-20 Rear Load and Door Cases Installation 1-21 Rear View Dimensions of Cases with External Sliding Rear Loading Doors 1-22 Apply Gaskets 1-24 Case Joining (Door & Rear Load Cases) 1-26 Installing, Removing, Adjusting Doors 1-28 Adjusting EcoVision Doors 1-28 Adjusting Door Closing Speed 1-29 Replacing LED Vertical Mullion Light Bars 1-29 Installing End Assemblies 1-30 Partition Hardware 1-35 Acrylic Partition Hardware 1-43 Installing Bumpers 1-46 Installing Night Blinds 1-47 Loading Blind Spring 1-49 Troubleshooting Night Blinds 1-50 REFRIGERATION / ELECTRICAL Refrigerant 2-1 Refrigerant Piping 2-1 Back Wall Piping Penetrations 2-2 Narrow and Wedge Case Connection use Shroud 2-3 Multiplexing 2-3 Line Sizing 2-3 Oil Traps 2-3 Pressure Drop 2-3 Insulation 2-3 Suction Line 2-3 Liquid Line 2-4 Refrigeration Thermostat 2-4 Defrost Sequences 2-4 Merchandiser Electrical Data 2-4 Electrical Connections 2-4 Field Wiring 2-4 Identification of Wiring 2-5 Sensor Location 2-5 Electrical Access for Sign-Ready & Flat-Front Fascias 2-6 Handling Electrostatic Sensitive Devices (Fan Selector) 2-7 Installing Type II Fan Speed Selector Kit 2-8 Type II Fan Speed Selector Location 2-9	DRIP PIPING / FIT & FINISH / SPLASHGUARDS Waste Outlet and Water Seal 3-1 Installing Drip Piping 3-2 Flush Floor Drip Piping Example for Ultra Low Front Cases 3-3 Optional Waste Outlet Drip Piping Example for Ultra Low Front Cases 3-4 Fascia Top Cap Alignment 3-7 Fascia Panel Alignment 3-8 Front Panel Alignment 3-10 Installing End Splashguards 3-11 Installing Splashguard Brackets 3-13 Installing Splashguards 3-14 Splashguard Alignment to Eliminate Gaps in Cases Line-Up 3-15 START UP / OPERATION Start Up/Operation 4-1 Load Limits 4-1 Stocking 4-1 Shelf Maximum Weight Limits 4-2 Multi-Deck Shelf Configuration 4-2 Installing Caseshield PTM(s) 4-3 LED Fixtures 4-4 Procedure for Installing Lighted Shelves 4-5 Shelf LED Clip Installation 4-7 Product Stop Installation 4-7 Installing FDA/NSF Required Thermometer 4-8 MAINTENANCE Care and Cleaning 5-1 Fan Plenum 5-1 Removable Return Air Grilles 5-1 Identification of Case Parts 5-2 Fascia Panels 5-3 Exterior Surfaces 5-3 Interior Surfaces 5-3 Recommended Cleaning Instructions 5-4 Weekly or Monthly 5-4 Quarterly or Semiannually 5-4 Cleaning Honeycomb Assemblies 5-5 Cleaning Mirrors 5-6 Removing Interior Back Panels 5-6 Bottom Liner Repair 5-7 Cleaning Coils 5-8 Cleaning Stainless Steel Front Rails 5-8 Removing Scratches from Bumper 5-8 Cleaning Under Merchandisers 5-8 SERVICE Replacing Fan Motors 6-1 Replacing Door Handles 6-3 Repairing Aluminum Coil 6-6 Warranty Information 6-7
---	--

ANSI Z535.5 DEFINITIONS

The definitions below are used to clarify the magnitude and urgency of harm and damage, considering problems arising from misuse. Relative to their potential danger, the definitions are divided into four parts according to ANSI Z535 Series.



DANGER indicates a hazardous situation which, if not avoided, will result in death or serious injury.



WARNING indicates a hazardous situation which, if not avoided, could result in death or serious injury.



CAUTION indicates a hazardous situation which, if not avoided, could result in minor or moderate injury.



NOTICE is used to address practices not related to personal injury.



SAFETY INSTRUCTIONS (or equivalent) signs indicate specific safety-related instructions or procedures.

INSIGHT INSTALLATION

TOOL LIST

(recommended)



Unloading From Trailer:

Lever Bar (also known as a Mule,
Johnson Bar, J-bar, Lever Dolly, and pry lever)

Moving Dolly



Setting Case Line-Up:

Level, 4 ft (suggested)

Ratchet

¼ in. Socket Drill Bit

5/16 in. Socket Drill Bit

½ in. Socket - Deep Drill Bit

½ in. Open End Wrench

Cordless Impact Drill

Caulking Gun

10 in. Adjustable Crescent Wrench

Pallet Jack

MANUAL REVISION HISTORY

REVISION R

1. Removed Page 5-4; Revised fan motor service instructions, Page 6-1, 6-2. Updated cleaning procedures, Page 5-1. Updated warning colors

REVISION Q

Not used

REVISION P

1. Revised procedures for fan motor harness connector, Section 5 & 6.

INSTALLATION

UL LISTING

These merchandisers are manufactured to meet ANSI/ UL 471 standard requirements for safety. Proper installation is required to maintain the listing.

FEDERAL / STATE REGULATIONS

These merchandisers at the time they are manufactured, meet all federal and state/ provincial regulations. Proper installation is required to ensure these standards are maintained. Near the serial plate, each merchandiser carries a label identifying the environment for which the merchandiser was designed for use. A Type II fan speed control kit is required for each merchandiser to operate at Type II conditions.

**ANSI/NSF-7 Type I – Display Refrigerator / Freezer
Intended for 75°F (24°C) / 55% RH Ambient Application**

**ANSI/NSF-7 Type II – Display Refrigerator / Freezer
Intended for 80°F / 55% RH Ambient Application**

**ANSI/NSF-7 – Display Refrigerator
Intended for Bulk Produce**

LOCATION

These merchandisers are designed for displaying products in air conditioned stores where temperature is maintained at or below the ANSI/ NSF-7 specified level and relative humidity is maintained at or below 55%.

Placing refrigerated merchandisers in direct sunlight, near hot tables or near other heat sources could impair their efficiency. Like other merchandisers, these are sensitive to air disturbances. Air currents passing around merchandisers will seriously impair their operation. Do NOT allow air conditioning, electric fans, open doors or windows, etc. to create air currents around the merchandisers.

PRODUCT TEMPERATURE

Product should always be maintained at proper temperature. This means that from the time the product is received, through storage, preparation and display, the temperature of the product must be controlled to maximize product life.

ATTENTION

Merchandiser must operate for 24 hours before loading product!

Regularly check merchandiser temperatures. Do not break the cold chain. Keep products in cooler or freezer before loading into merchandiser.

Medium temperature merchandisers are designed for loading ONLY pre-chilled products.

Low temperature merchandisers are designed for loading ONLY frozen products.



A 1.5 inch (38 mm) space between the rear of the merchandiser and wall must be maintained for air circulation. However, in high ambient conditions, sweating may still occur. If this happens install a method of forced ventilation such as a fan ventilation kit.

⚠ WARNING

- » Use caution when working around refrigeration lines or water lines. Damage to equipment and/or personal injury could occur.

SHIPPING DAMAGE

All equipment should be thoroughly examined for shipping damage before and during unloading.

This equipment has been carefully inspected at our factory. Any claim for loss or damage must be made to the carrier. The carrier will provide any necessary inspection reports and/or claim forms.

Apparent Loss or Damage

If there is an obvious loss or damage, it must be noted on the freight bill or express receipt and signed by the carrier’s agent; otherwise, carrier may refuse claim.

Concealed Loss or Damage

When loss or damage is not apparent until after equipment is uncrated, retain all packing materials and submit a written request to the carrier for inspection, within 15 days.

UNLOADING

Improper handling may cause damage to the merchandiser when unloading. Use the shipping brace and arched pod locations to lift when unloading cases.

1. Do not drag the merchandiser out of the trailer. Use a Johnson bar (mule).
2. Do not lift the case by the liner. Lift with the metal case base, arched plastic pods or the shipping brace.
3. Do not lift from the bottom edge of the end panel.

EXTERIOR LOADING

Do NOT walk on top or inside of merchandisers or damage to the merchandisers and serious personal injury could occur. **THEY ARE NOT STRUCTURALLY DESIGNED TO SUPPORT EXCESSIVE EXTERNAL LOADING** such as the weight of a person. Use caution when working around refrigeration lines or water lines, damage to equipment and personal injury could occur.

⚠ WARNING

» If the case is to be moved using a fork lift, position the forks of the lift directly under the arched pods or shipping rails. Use extreme caution when transporting cases. Personal injury or death could result if a case falls on personnel.

⚠ WARNING

» Do not walk on case. Do not store items or flammable materials atop the case.

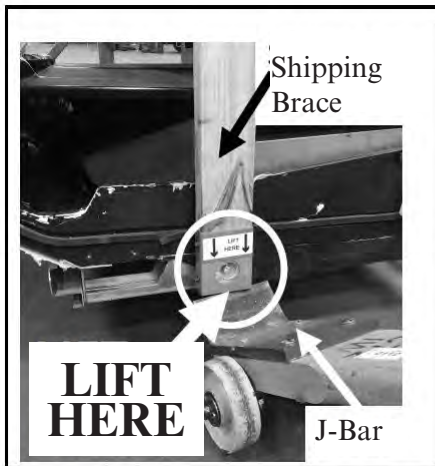

LIFT POINTS
Shipping Brace & Arched Pod

Installer lift at either of **THESE POINTS** with J-Bar when moving case.

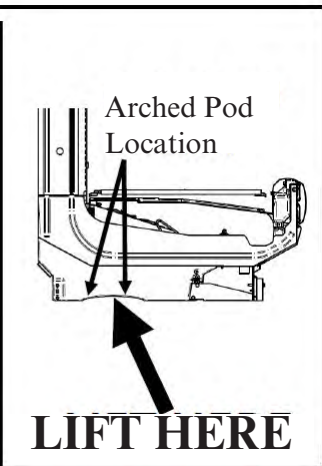

UNLOADING USING A PALLET JACK

A pallet jack is also very helpful in moving a merchandiser to its permanent location. It can also be used to remove optional casters or to shim the case.



OPTIONAL CASTERS AND DOLLIES

Cases may be equipped with factory installed casters or dollies. Instructions for removing the casters or dollies are included in a separate document, shipped with the case. Use caution when transporting cases from the truck to the store location.

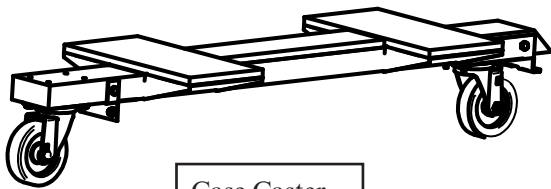

Case Caster

⚠ WARNING

» Use caution when moving cases with casters or dollies. Damage to equipment and personal injury could occur from improper handling.

SERIAL PLATE LOCATION

Serial plates are located on the left side, facing the case. The serial plate contains information about the specific model and its operating parameters.

NOTE: A second serial plate for multi-deck cases is also located behind the return air grille in the same location as single-deck cases (shown below).

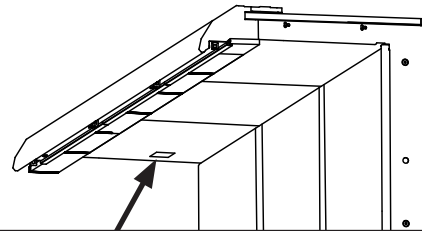

Serial Plate inside Canopy (multi-deck)

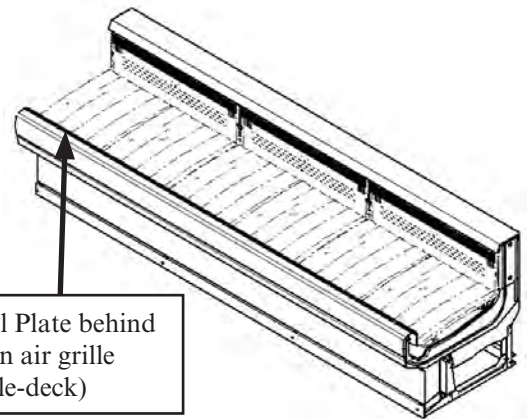

Serial Plate behind return air grille (single-deck)

QR CODE

Insight cases have a QR code located on the serial plate(s). Once you scan the QR code with a smart phone, all of the information about that case will be at your fingertips. Links to installation videos, data sheets with case specifications, the installation and operation manual, as well as a link to replacement parts from Hussmann’s Performance Parts Website.



MERCHANDISERS SHIPPED WITH END INSTALLED

If the merchandiser was shipped with the end installed, two long bolts were used to hold the shipping brace to the end. If the shipping bolts are reinserted after removing the brace, they will extend into the product area. **THEREFORE, BE SURE TO REPLACE THESE BOLTS WITH THE SHORTER BOLTS PROVIDED.** NSF requires any bolt or screw in the product area be capped or cut off if it has more than three exposed threads.



Be careful not to damage the factory installed end while moving the merchandiser.

CAUTION
» Do not remove shipping braces until the merchandisers are positioned for installation.

END SHIPPING BRACES

Move the merchandiser as close as possible to its permanent location, then remove all packaging. Check for damage before discarding packaging. Remove all separately packed accessories such as kits and shelves.

Do not remove end braces until joining begins. Recycle wooden braces and hardware.

SHIPPING RIDER

Some merchandisers are shipped on a rider to protect the factory installed front legs, and to make positioning the merchandiser easier. To remove the rider, remove bolts attaching rider to each leg.

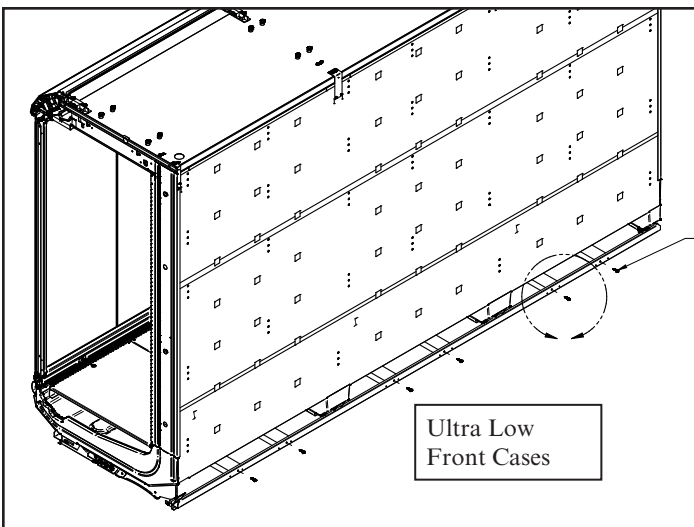
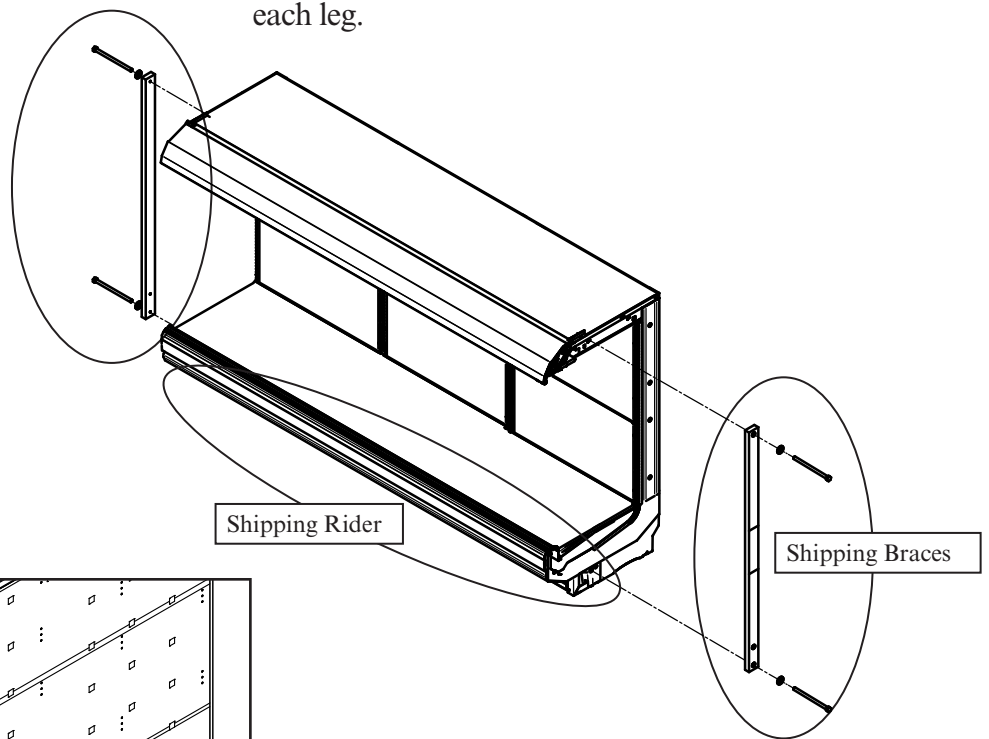

Remove 6 Screws and Wooden Supports Prior to Moving Case into Position (rear rail will remain attached to merchandiser)

MERCHANDISER LEVELING

IMPORTANT

Merchandisers must be installed level to ensure proper operation of the refrigeration system and to ensure proper drainage of defrost water. Pay close attention to case position during all steps of setting, joining and leveling.

NOTE: BEGIN LINEUP LEVELING FROM THE HIGHEST POINT OF THE STORE FLOOR.

Preparation

1. Using store blueprints, measure off and mark on floor the exact dimensions/locations of the merchandiser footprint. **A 1½ inch space is required behind each merchandiser to prevent condensation.**
2. Snap a chalk line for the front and rear positions of the base pods.
3. Mark the location of each joint from front to back lines.
4. **USE SUPPLIED SHIMS TO LEVEL CASE. Shims are to be inserted under the black, plastic base pods.**

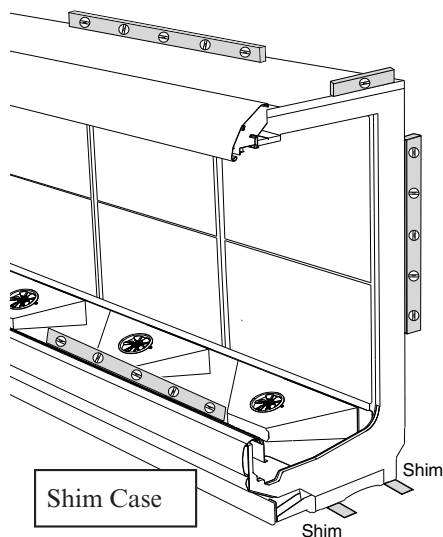

CAUTION

- » Tipping Hazard! Case tipping may occur if cases are not properly leveled and secured, or if cases are not properly loaded.



Case Lineup Leveling

1. **FLOORS ARE NOT LEVEL!** The whole lineup must be leveled on the same plane, left to right and front to back. This means that the entire lineup must be brought up to the level of the highest case in the lineup.

Along the lines previously marked, find the highest point of the floor by:



















- Walking the floor and noticing any dips or mounds;
- Using a string level; and
- Using a transit.

2. Position the first merchandiser at the highest point on the floor. Work outward from that point to create the merchandiser lineup.
3. Use a 48 inch (1220 mm) or longer level for end-to-end leveling. The rear edge of the top foam panel of the merchandiser is a good location for the level at the rear of the case.
4. For leveling the merchandiser front-to-rear, a 24 inch (610 mm) level should be placed on the lower flange of the merchandiser end frame. If the merchandiser has a factory installed end, the level should be placed on the canopy support brackets on top of the merchandiser. Suggested level locations are shown in the illustration.

Note:
See PAGE 1-21 at end of manual for joining rear load and door cases.

JOINING OPEN CASES IN A LINEUP

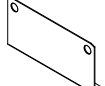
JOINING AND SEALING HARDWARE	Multi Deck Qty/Each	Convertible Qty/Each	Single Deck Qty/Each	Door Multi Deck Qty/Each
SEALER SILICONE ADHESIVE	1	1	1	1
GASKET 1/2 X 1/2 X 180	2	1	1	2
SCREW-SHEET METAL #8 X 5/8 PHIL HX HD	N/A	1	N/A	N/A
SCREW-CAP 1/4 x 3/4 HEX	N/A	N/A	N/A	2
BOLT HEX CAP 5/16 x 3/4	1	1	1	1
BOLT 5/16 x 2 3/4 GRADE 5 ZINC PLATED TAP	2	N/A	N/A	2
BOLT- TAP, 5/16 x 4 1/2, STEEL, ZINC FINISH, GR5 (Qty Varies)	5	2	1	5
BOLT- TAP, 5/16 x 7, STEEL, ZINC FINISH, GR5	1	1	1	1
WASHER-FLAT 5/16" ZINC (Qty Varies)	13	5	3	13
LOCKWSHR 1/4 SPLT STL	N/A	N/A	N/A	2
LOCKWSHR 5/16 SPLT STL	1	1	1	1
NUT-HEX 1/4	N/A	N/A	N/A	2
NUT-HEX 5/16 STEEL ZINC FINISH GRADE 8 (Qty Varies)	9	4	3	9
NUT-HEX 3/8-24 SERRATED FLANGE	4	N/A	N/A	4
PIN-ALIGNMENT	1	1	1	N/A
CONE-CASE ALIGNMENT (Qty Varies)	4	2	2	4
PLATE-BOTT DOOR RAIL ALIGNMENT	N/A	N/A	N/A	1
BRACKET-CASE JOINING	4	N/A	N/A	4
BRACKET-FASCIA ALIGNMENT IC2 & IC3	N/A	1	N/A	N/A
COVER-HAND RAIL JOINT	1	1	1	N/A
TAPE-BUTYL 1/16 x 2" X 49"	1	1	1	1

- Screw-Sheet Metal #8 x 5/8 
- Screw-Cap 1/4 x 3/4 
- Bolt-5/16 x 3/4 
- Bolt-5/16 x 2 3/4 
- Bolt-5/16 x 4 1/2 
- Bolt-5/16 x 7 
- Washer Flat-5/16 
- Washer Lock-1/4 
- Washer Lock-5/16 
- Nut Hex-1/4 
- Nut Hex-5/16 
- Nut Hex-3/8 Serr Flange 
- Pin-Alignment 
- Cone-Alignment 
- Plate-Bottom Door Rail Alignment 
- Bracket-Case Joining 
- Bracket-Fascia Alignment IC2 & IC3 
- Cover-Handrail Joint 

IMPORTANT:

Do not pull cases together with bolts. Cases must be moved together as close as possible. Follow sequence balloons to tighten bolts.

Apply gasket to only one side of case joint.

Remove end shipping braces as described on Page 1-4.

Cases must be leveled as described on Page 1-5.

Removed any casters - if installed.

Install case lineup from left to right.

Remove shelves, display racks, pans & interior back panels at the joining area.

Insert gasket into case channels the entire length with no gaps.

Do not stretch gasket, especially around corners.

Do not butt gaskets, always overlap them.

Remove paper backing after gasket has been applied.

Perimeter gasket is required by NSF.

Apply a continuous bead of neutral curing silicone sealant.

Joints must be air tight to prevent formation of ice or condensation.

APPLY GASKETS

(MULTI-DECK)

IP4 / IM5 / ID5 / ID6 / IC6 / IC4

Case bolting details begin on the next page.

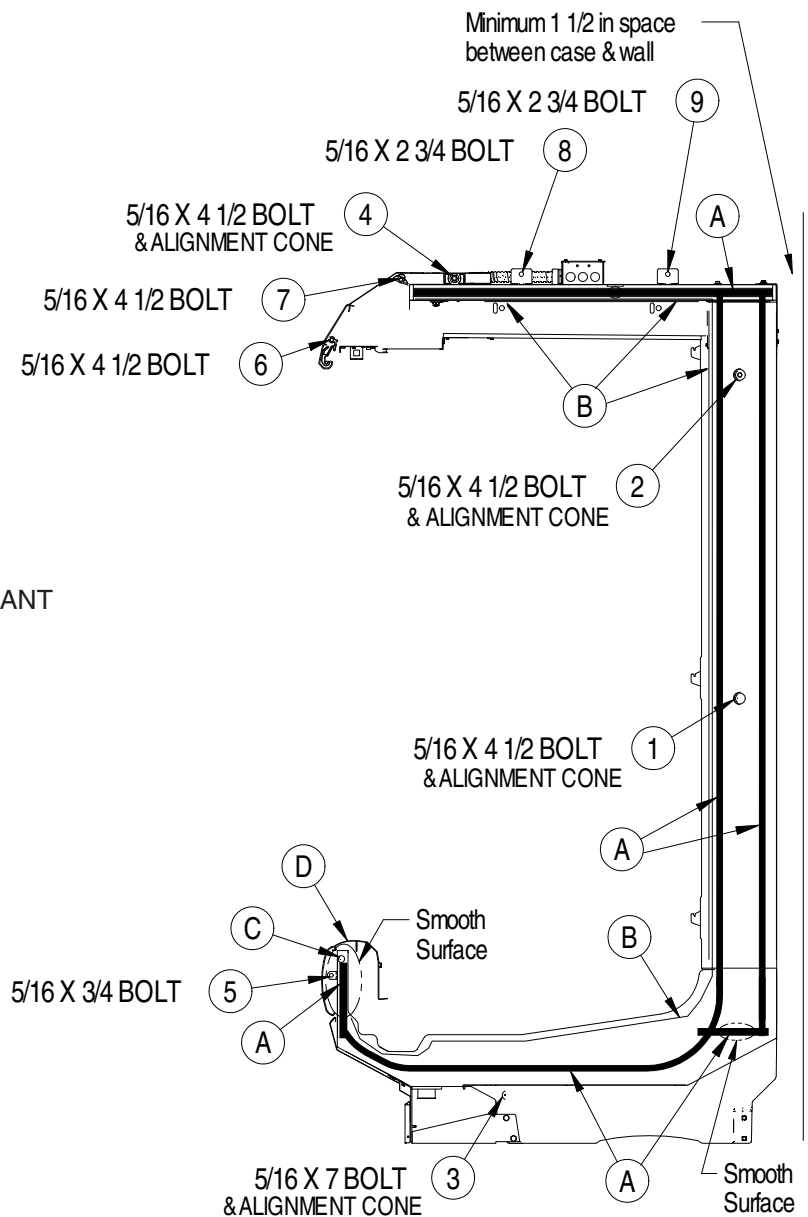

LEGEND:

A = 1/2 x 1/2 INCH GASKET

B = NEUTRAL CURING SILICONE SEALANT

C = PIN-ALIGNMENT

D = COVER-HAND RAIL JOINT

IMPORTANT:

Do not pull cases together with bolts. Cases must be moved together as close as possible Follow sequence balloons to tighten bolts.

Merchandiser case joint & end gasket to be applied on only one side of joint.

Merchandiser partition gasket to be applied on both sides of joint.

Remove end shipping braces as described on Page 1-4

Cases must be leveled as described on Page 1-5

Removed any casters - if installed

Install case lineup from left to right

Remove shelves, display racks, pans & interior back panels at the joining area

Insert gasket into case channels the entire length with no gaps

Do not stretch gasket, especially around corners

Do not butt gaskets, always overlap them

Remove paper backing after gasket has been applied

Perimeter gasket is required by NSF

Apply a continuous bead of neutral curing silicone sealant

Joints must be air tight to prevent formation of ice or condensation.

CASE JOINING (MULTI-DECK / REAR LOAD)
IP4 / IM5 / ID5 / ID6 / IC6 / IC4

Refer to detail views

LEGEND:

C = PIN-ALIGNMENT

Do not pull cases together with bolts. Cases must be moved together as close as possible. Follow sequence balloons 1, 2, 3 to tighten bolts.

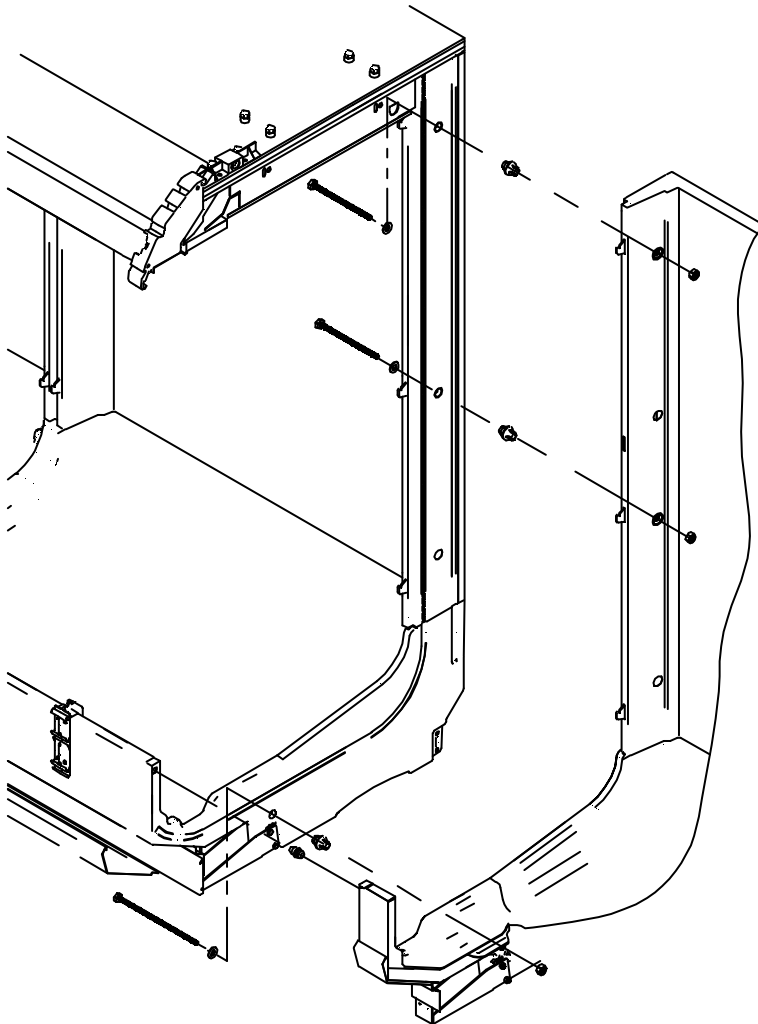
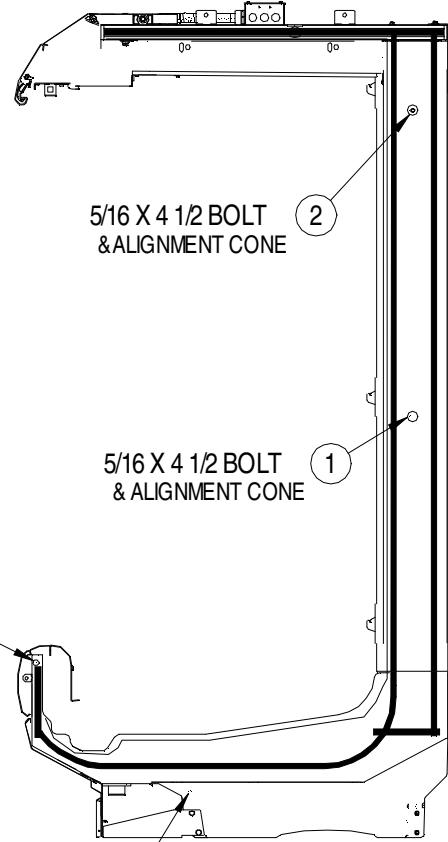

CASE JOINING (MULTI-DECK / REAR LOAD)

IP4 / IM5 / ID5 / ID6 / IC6 / IC4

Refer to detail views

This Bolt location is optional for some installed kits.

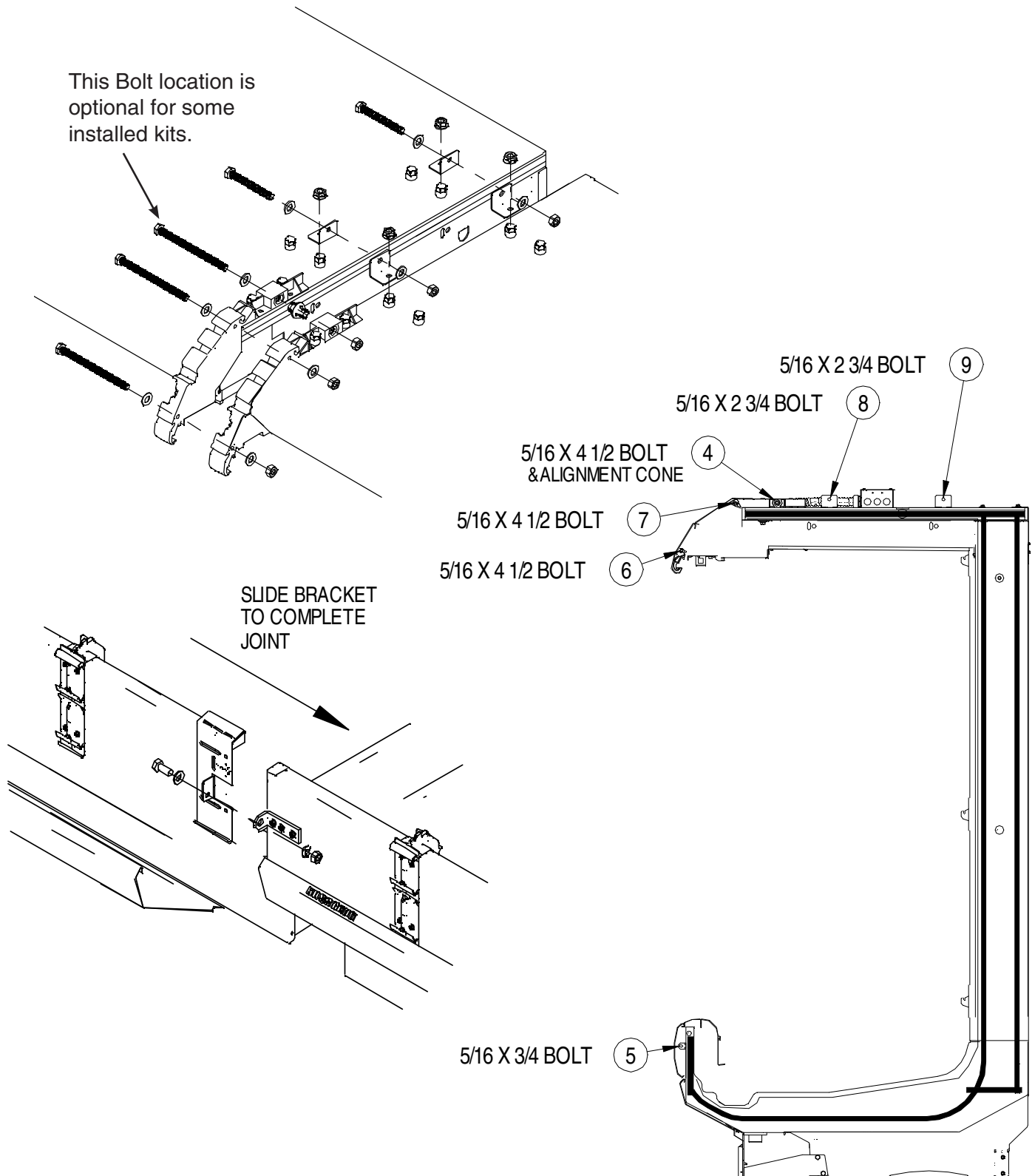

1-10

CASE JOINING (MULTI-DECK / REAR LOAD)

IP4 / IM5 / ID5 / ID6 / IC6 / IC4

Refer to detail views

LEGEND:

D = COVER-HAND RAIL JOINT

Push Cover
in this direction
to snap fit

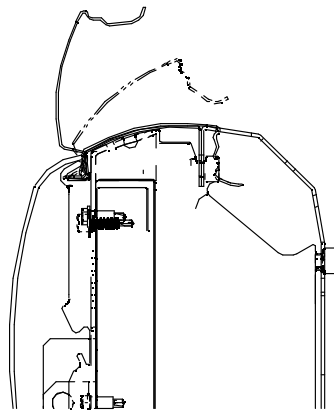

Cover-Hand Rail Joint

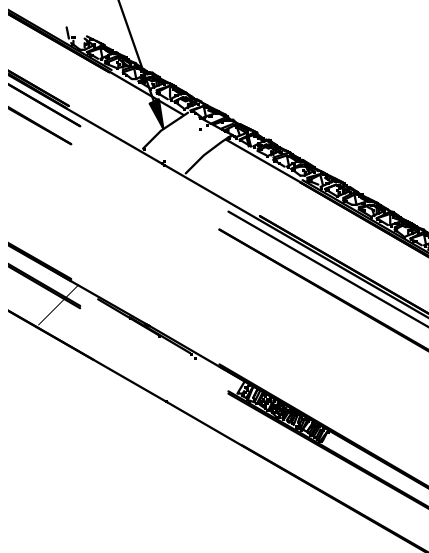

D

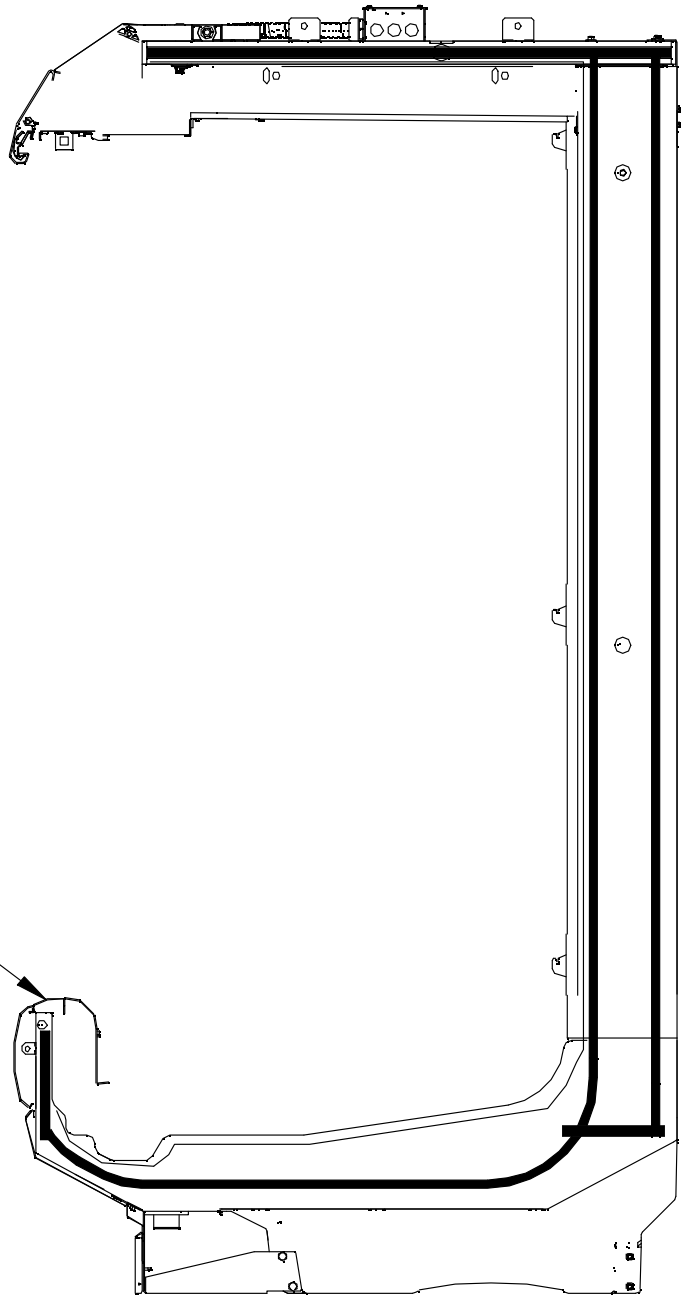

**APPLY GASKETS
(CONVERTIBLE)
IC2 / IC2X / IC3**

Case bolting details begin on the next page.

LEGEND:

- A=1/2 X 1/2 INCH GASKET
- B=NEUTRAL CURING SILICONE SEALANT
- C=PIN-ALIGNMENT
- D=COVER-HAND RAIL JOINT
- E=BRACKET-FASCIA ALIGNMENT

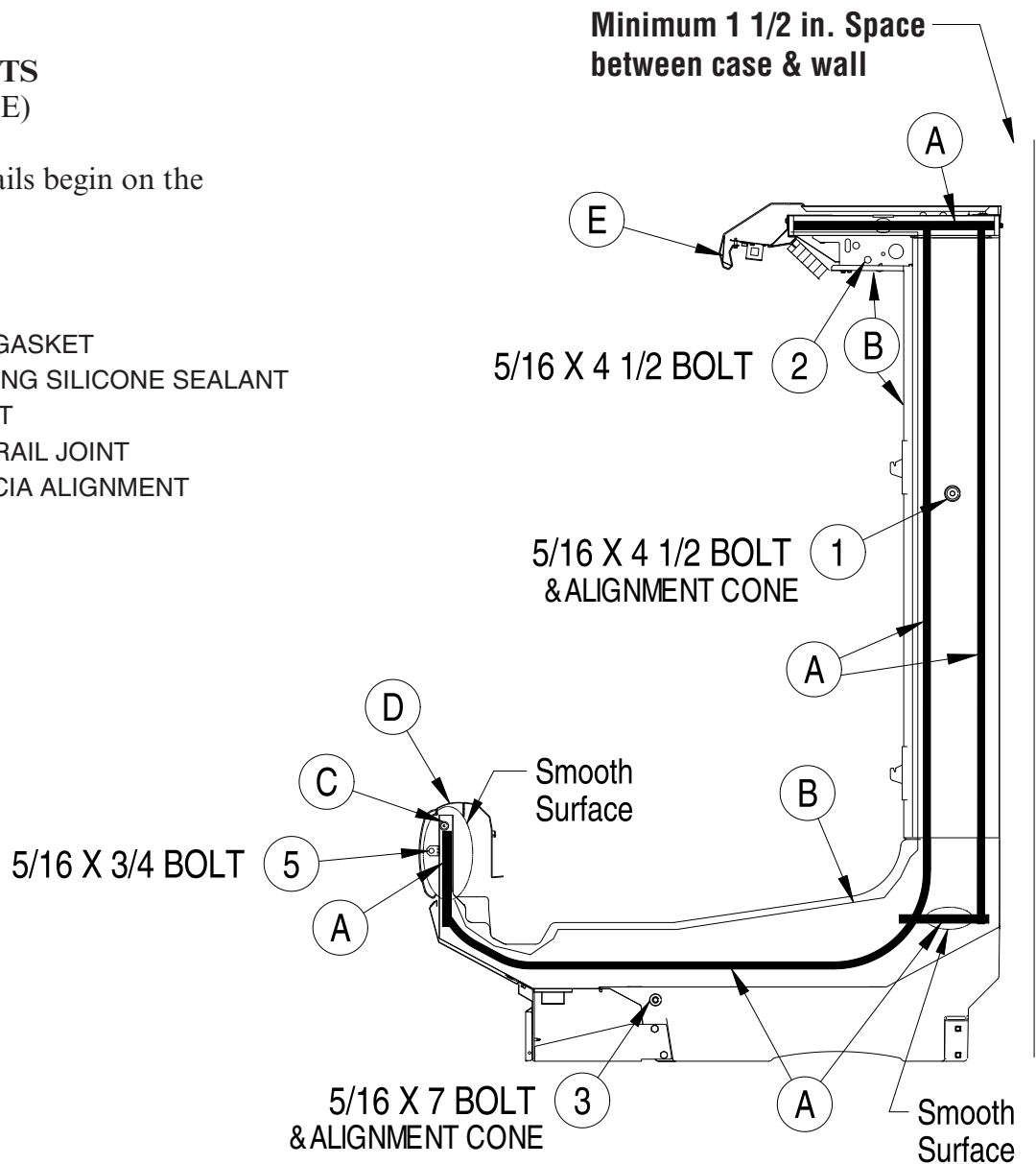

IMPORTANT:

Do not pull cases together with bolts. Cases must be moved together as close as possible Follow sequence balloons to tighten bolts.

Merchandiser case joint & end gasket to be applied on only one side of joint.

Merchandiser partition gasket to be applied on both sides of joint.

Remove end shipping braces as described on Page 1-4

Cases must be leveled as described on Page 1-5

Removed any casters - if installed

Install case lineup from left to right

Remove shelves, display racks, pans & interior back panels at the joining area

Insert gasket into case channels the entire length with no gaps

Do not stretch gasket, especially around corners

Do not butt gaskets, always overlap them

Remove paper backing after gasket has been applied

Perimeter gasket is required by NSF

Apply a continuous bead of neutral curing silicone sealant

Joints must be air tight to prevent formation of ice or condensation.

CASE JOINING (CONVERTIBLE)

IC2 / IC2X / IC3

Refer to detail views

LEGEND:

C=PIN-ALIGNMENT

E=BRACKET-FASCIA ALIGNMENT

Do not pull cases together with bolts. Cases must be moved together as close as possible. Follow sequence balloons to tighten bolts.

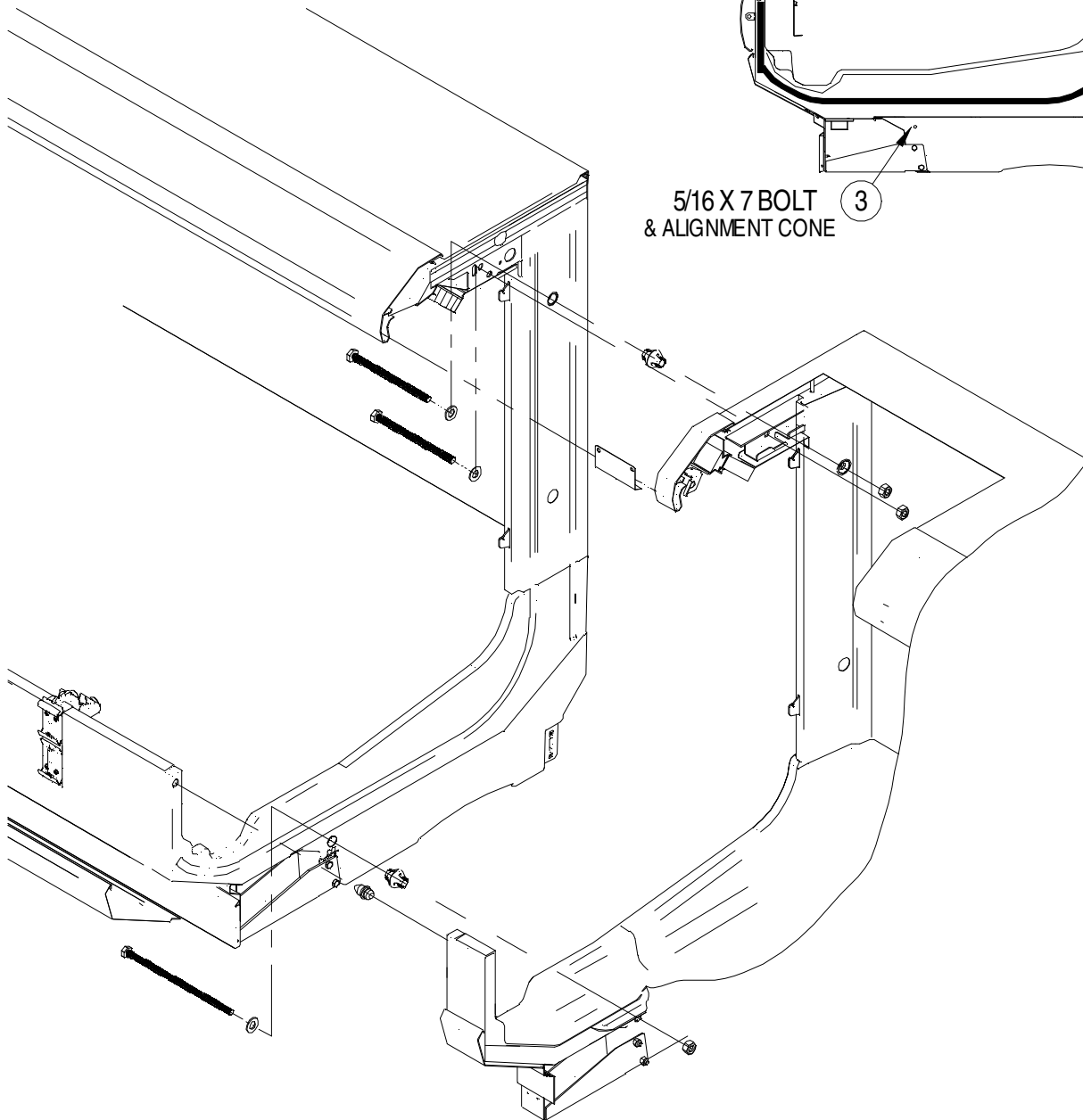
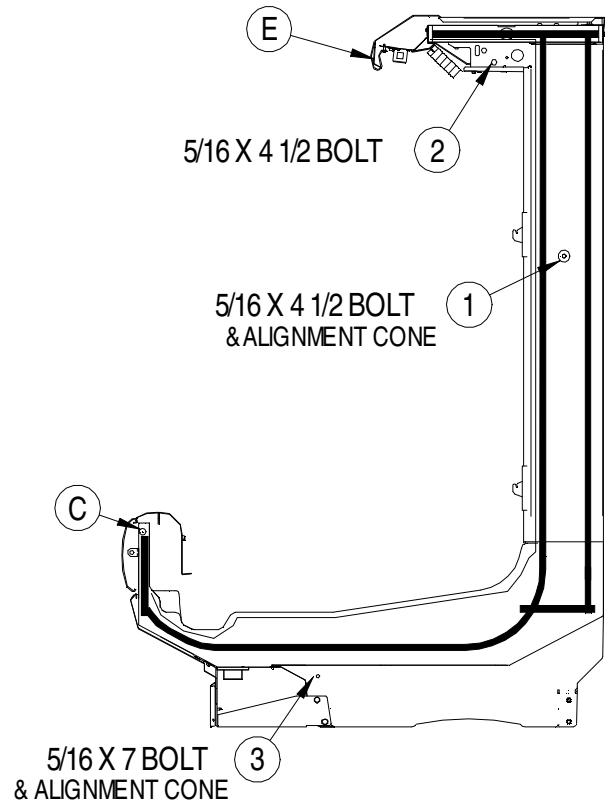

**CASE JOINING (CONVERTIBLE)
IC2 / IC2X / IC3**

Refer to detail views

LEGEND:

E=BRACKET-FASCIA ALIGNMENT

(Can be modified by hand for better fit if necessary)

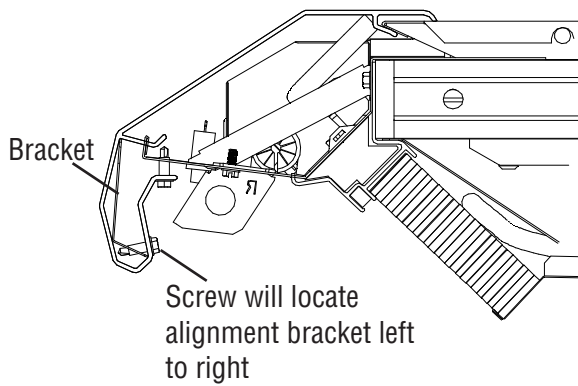
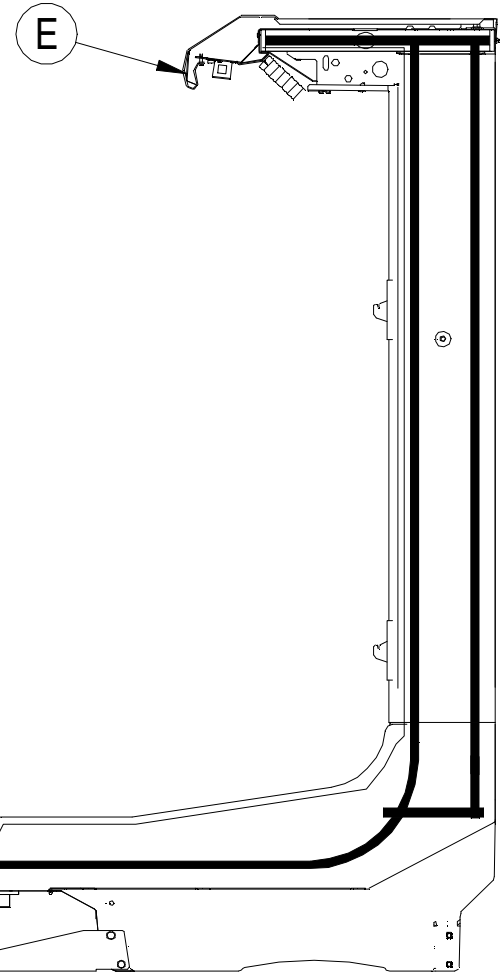

**Faceted Fascia
right side view**

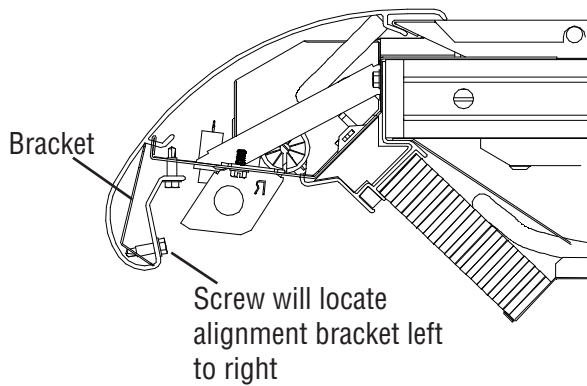

**Ellipse Fascia
right side view**

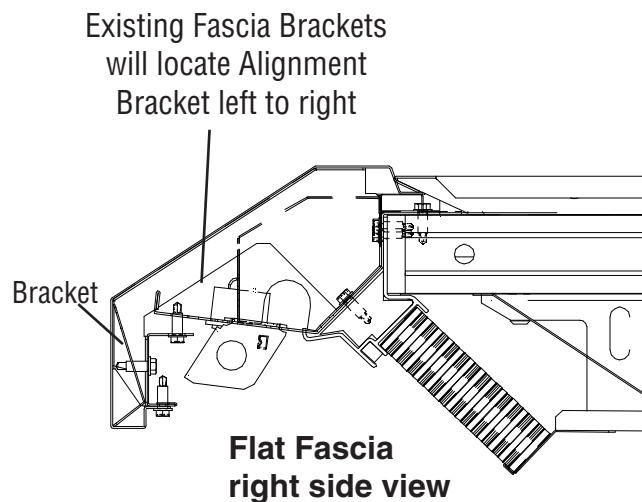

**Flat Fascia
right side view**

CASE JOINING (CONVERTIBLE)

IC2 / IC2X / IC3

Refer to detail views

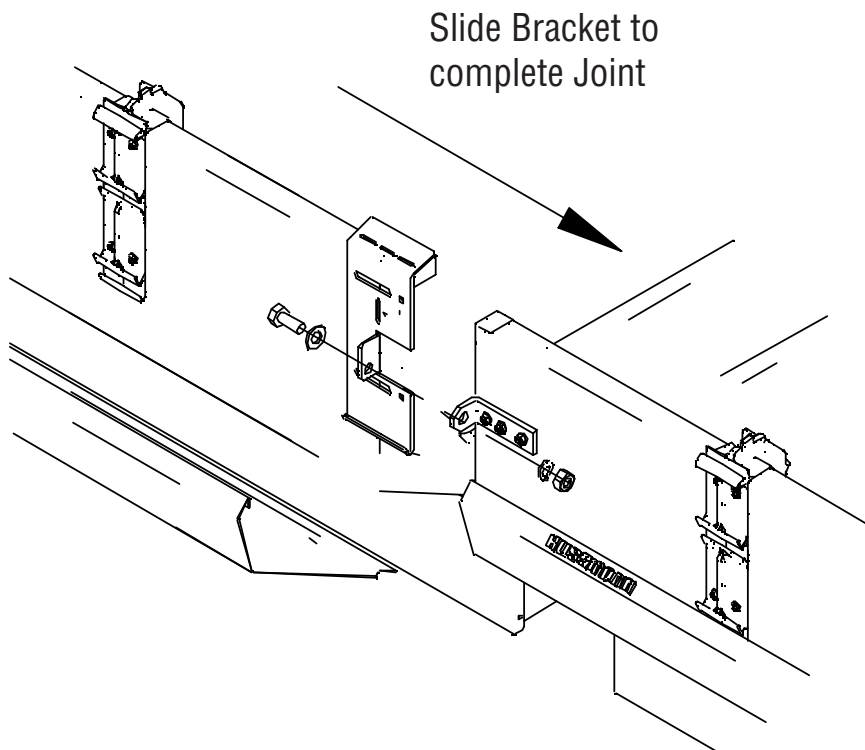
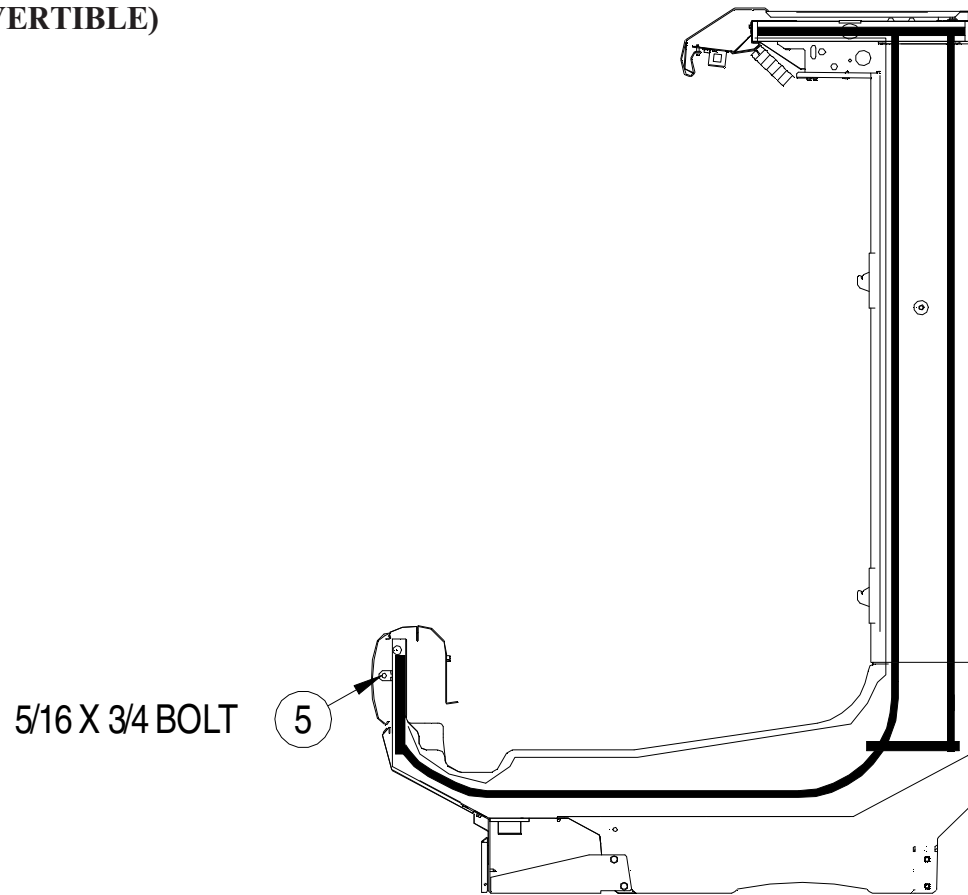

CASE JOINING (CONVERTIBLE)

IC2 / IC2X / IC3

Refer to detail views

LEGEND:

D = COVER-HAND RAIL JOINT

Push Cover
in this direction
to snap fit

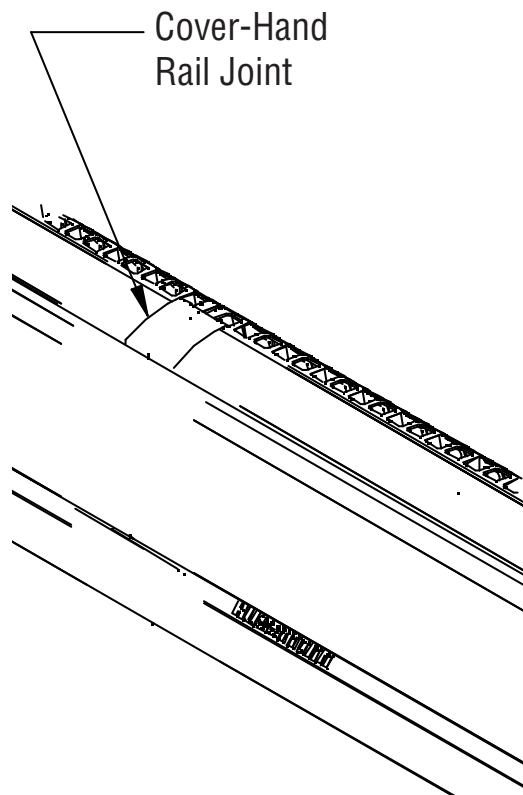
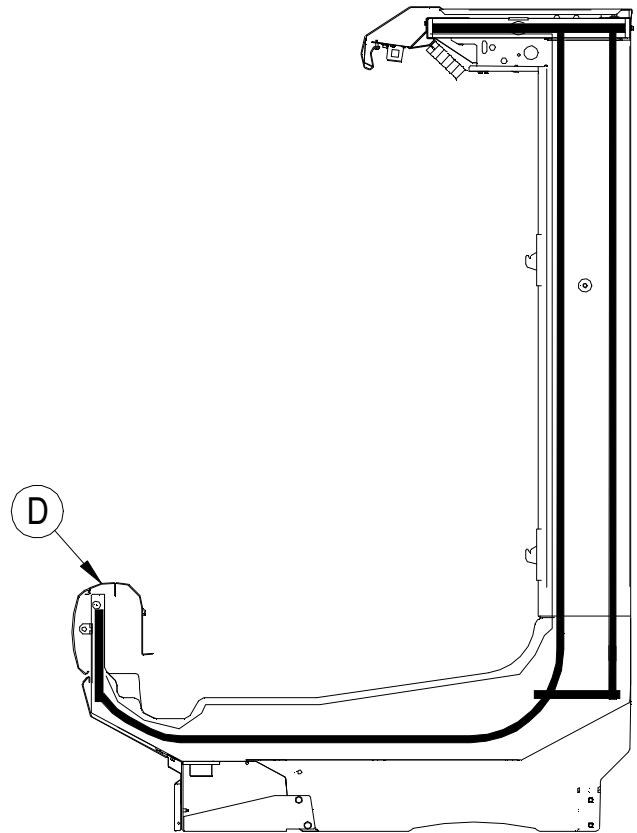
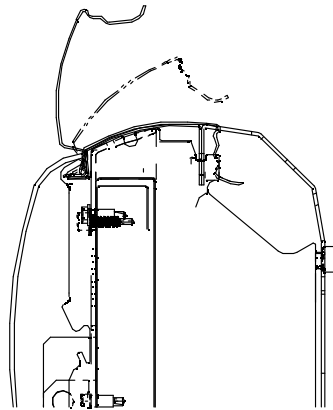

**APPLY GASKETS
(SINGLE-DECK)**

IIM1 / IP1

Case bolting details begin on the next page.

LEGEND:

A = 1/2 x 1/2 INCH GASKET

B = NEUTRAL CURING SILICONE SEALANT

C = PIN-ALIGNMENT

D = COVER-HAND RAIL JOINT

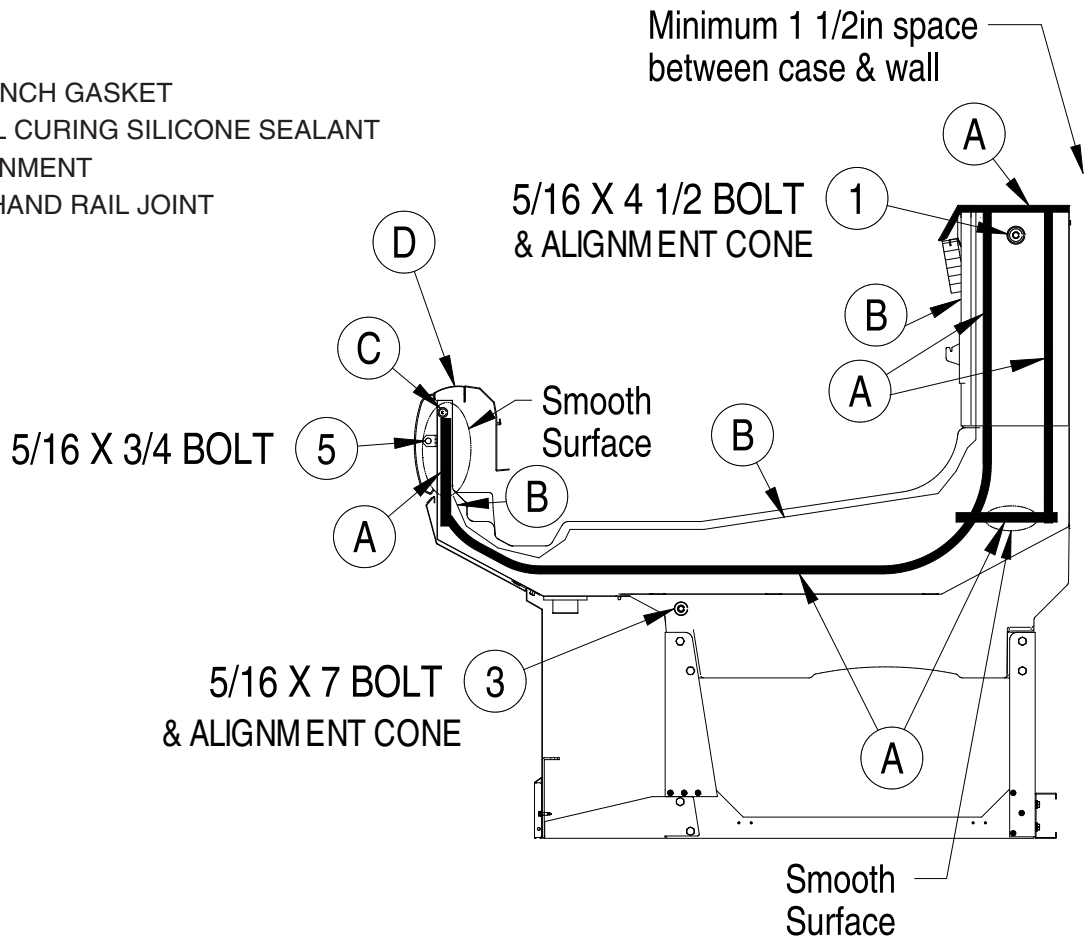

IMPORTANT:

Do not pull cases together with bolts. Cases must be moved together as close as possible Follow sequence balloons to tighten bolts.

Merchandiser case joint & end gasket to be applied on only one side of joint.

Merchandiser partition gasket to be applied on both sides of joint.

Remove end shipping braces as described on Page 1-4

Cases must be leveled as described on Page 1-5

Removed any casters - if installed

Install case lineup from left to right

Remove shelves, display racks, pans & interior back panels at the joining area

Insert gasket into case channels the entire length with no gaps

Do not stretch gasket, especially around corners

Do not butt gaskets, always overlap them

Remove paper backing after gasket has been applied

Perimeter gasket is required by NSF

Apply a continuous bead of neutral curing silicone sealant

Joints must be air tight to prevent formation of ice or condensation.

CASE JOINING (SINGLE DECK)

IM1 / IP1

Refer to detail views

LEGEND:

C = PIN-ALIGNMENT

Do not pull cases together with bolts. Cases must be moved together as close as possible. Follow sequence balloons to tighten bolts.

5/16 X 4 1/2 BOLT
& ALIGNMENT CONE

1

C

3

5/16 X 7 BOLT
& ALIGNMENT CONE

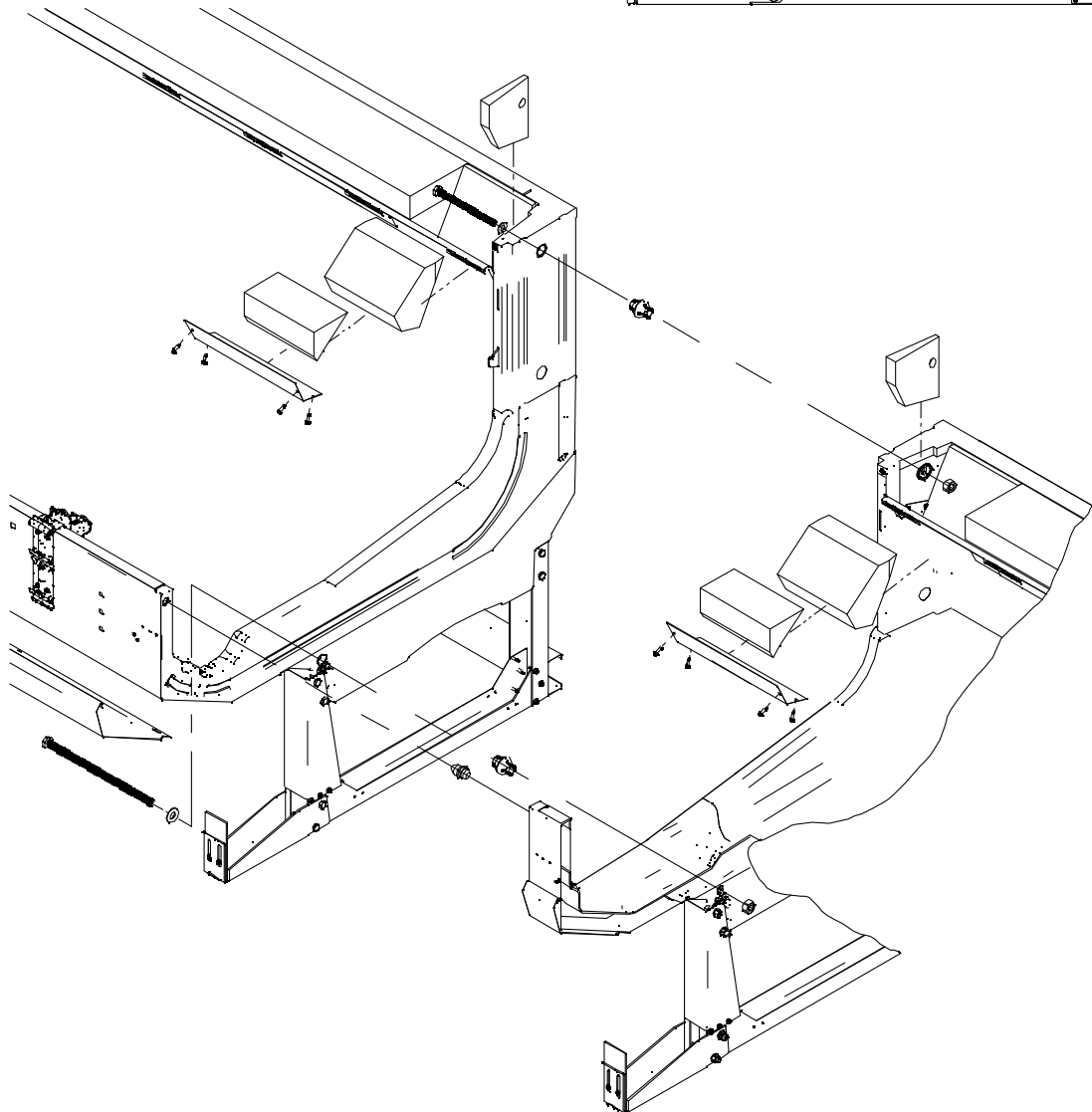

CASE JOINING (SINGLE DECK)
IM1 / IP1
Refer to detail views

5/16 X 3/4 BOLT

5

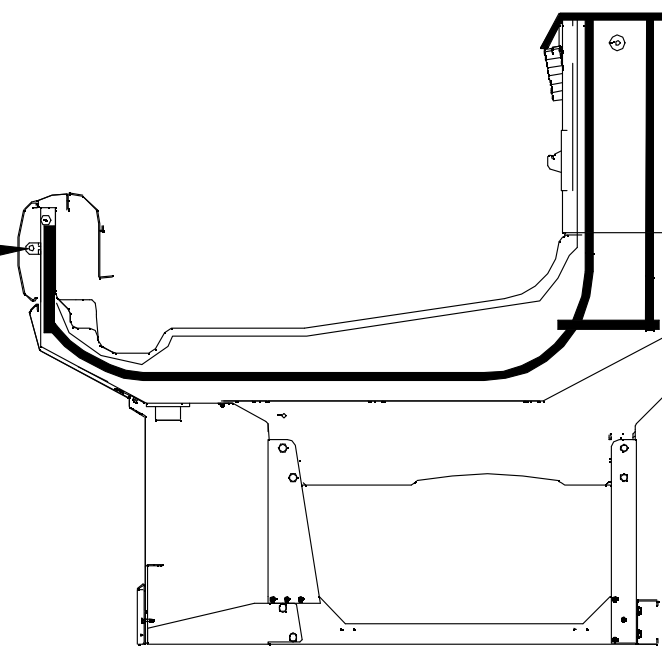

Slide Bracket to
complete Joint

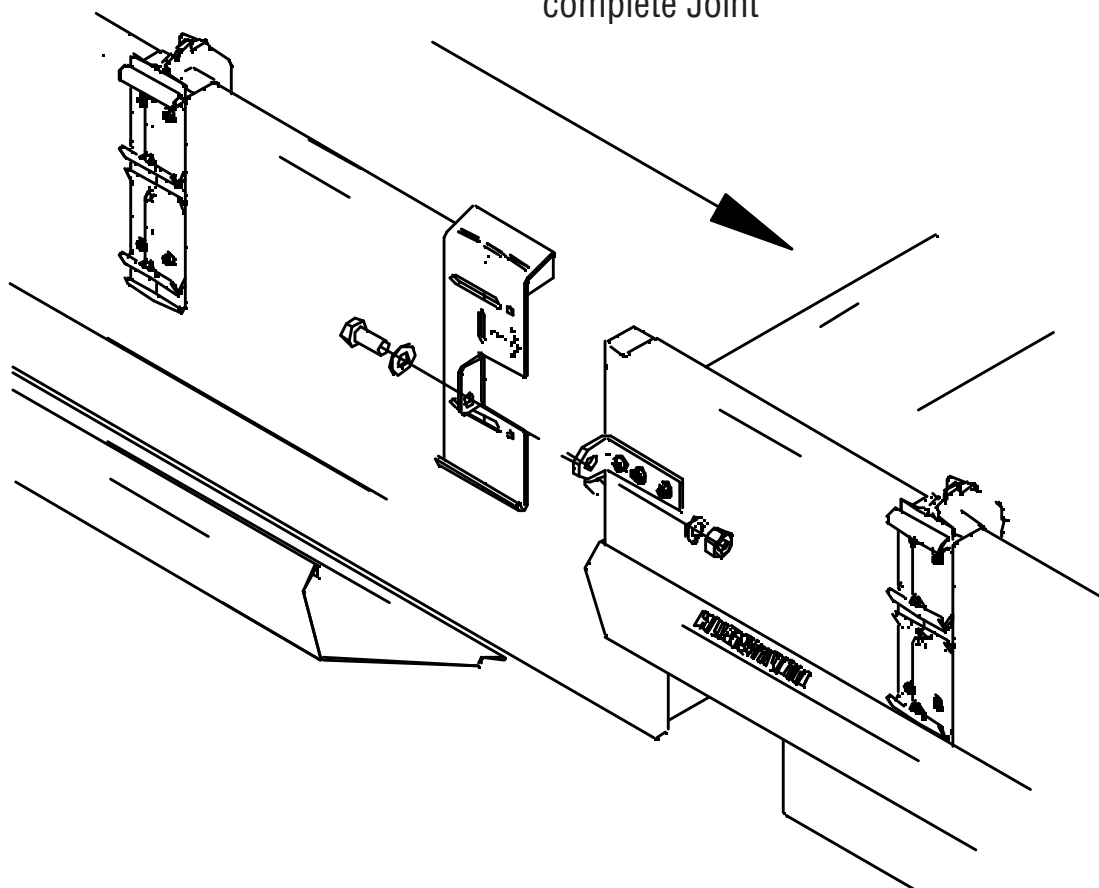

CASE JOINING (SINGLE DECK)

IM1 / IP1

Refer to detail views

LEGEND:

D = COVER-HAND RAIL JOINT

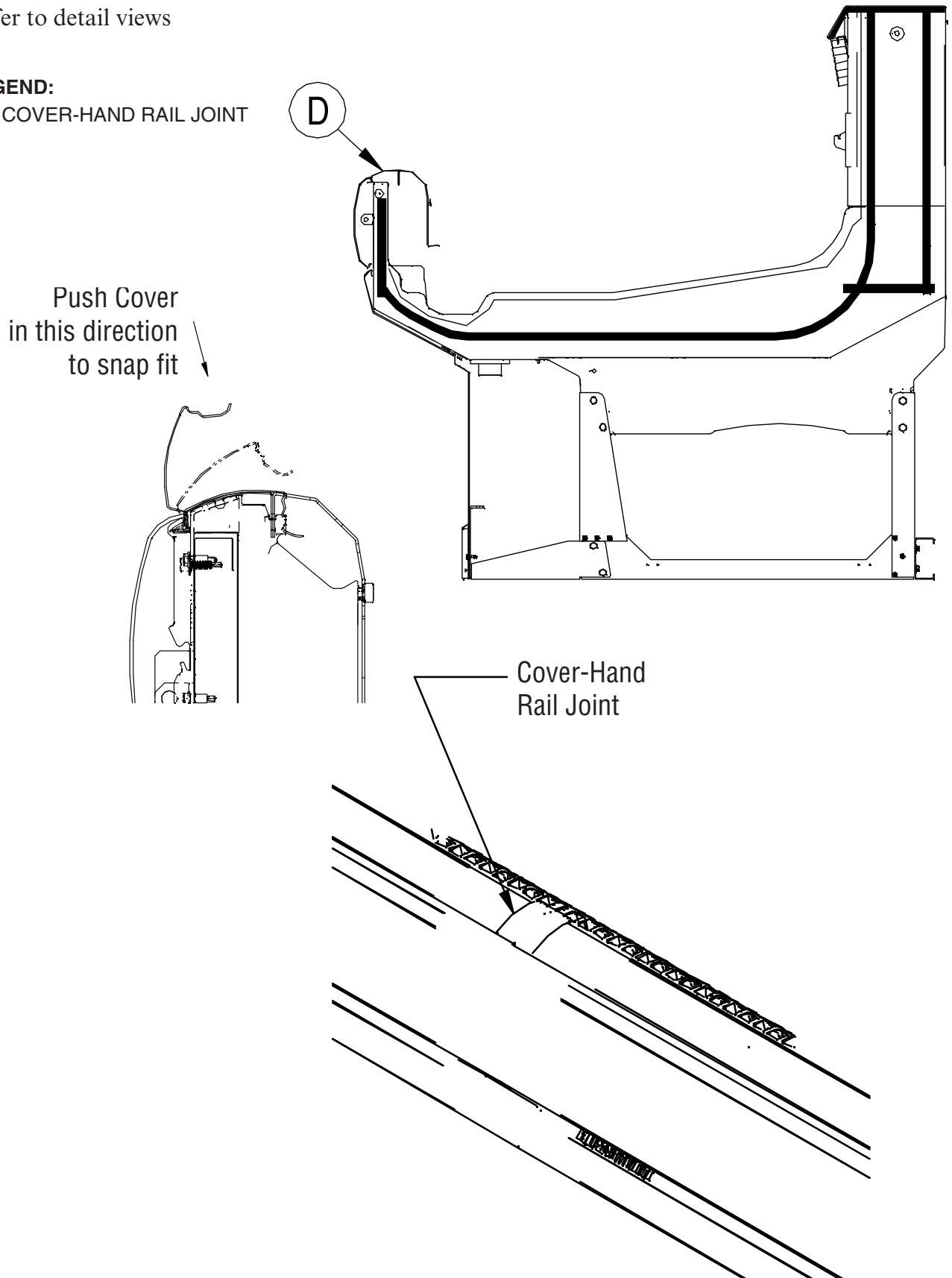

Sealing Lineup Joints (all cases)

The joint between the two joined case must be sealed for sanitation. Apply Butyl tape across the case joint. Apply a long, continuous bead of silicone to fill any gaps between the cases.

Be sure to start from the back and go all the way to the air return as shown in the illustration below.

⚠ WARNING

» Use caution when working around refrigeration lines or water lines, damage to equipment and personal injury could occur.

📄 IMPORTANT Fill any gaps between cases with silicone.

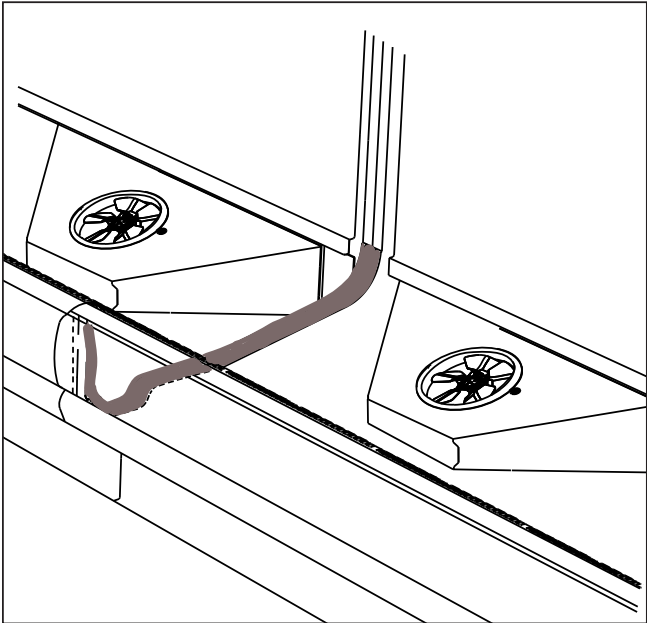

Apply Butyl Tape

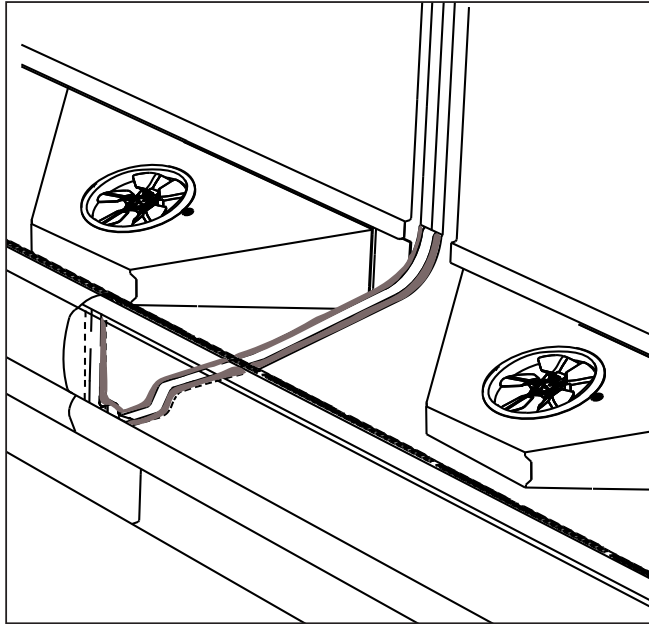

Apply Neutral Curing
Silicone Sealant

**Apply Neutral Curing Silicone Sealant
in any gaps between the Case Joints.**

REAR LOAD AND DOOR CASES INSTALLATION

REAR LOAD

SEALING CASE(S) IN FRONT OF COOLER OPENING

Rear load cases are designed to be installed in the cooler opening. A 1½ in. gap around the outside of the cooler opening must be maintained. Use the dimensions below to build a sealed wall between the cooler opening and the rear of the case(s). Use silicone around the perimeter of the frame to seal the cases on the inside and outside of the cooler.

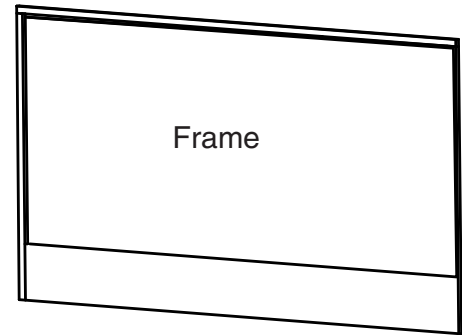

A frame must be built between the cooler opening and the rear loading area of the case(s). Seal the frame with silicone. The area around the rear access doors should be sealed to the cooler wall. The seal should be air and water tight.

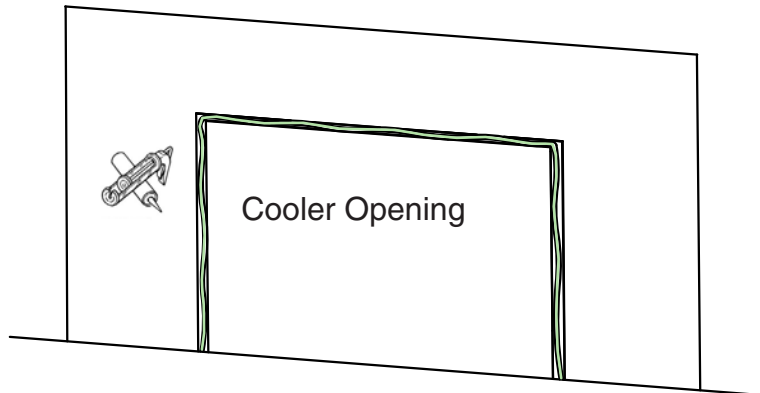

Rear Access Doors

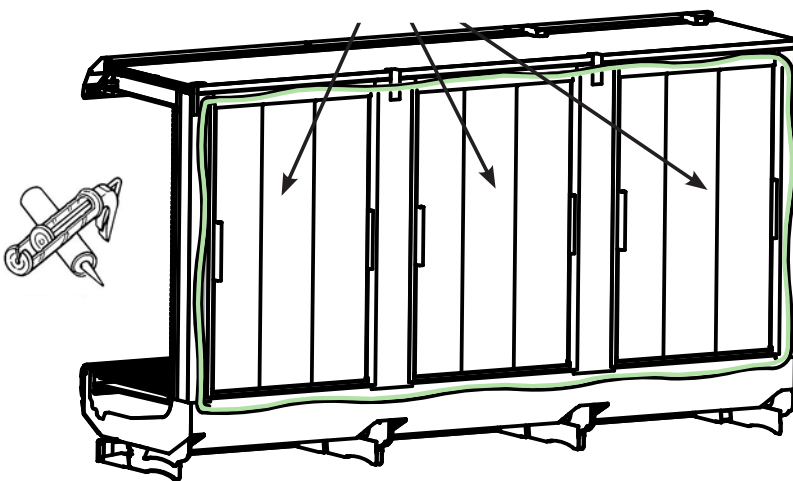

**REAR VIEW DIMENSIONS ID6SUR / ID5SLR
OF CASES WITH EXTERNAL SLIDING
REAR LOADING DOORS
(4 ft, 6 ft, 8 ft, 12 ft)**

Item	ID6SUR Merchandisers			
	4ft	6ft	8ft	12ft
A	6 ¹ / ₈ (155)			
B	67 ¹ / ₂ (1724)			
C	16 ¹ / ₈ (419)			
D	5 ¹ / ₈			
* E	12 ¹ / ₄ (309)	8 ¹ / ₈ (206)	12 ¹ / ₄ (309)	12 ¹ / ₄ (309)
* F	24 ⁷ / ₈ (631)	17 (430)	24 ⁷ / ₈ (631)	24 ⁷ / ₈ (631)
G	37 ¹ / ₈ (941)	25 ¹ / ₈ (636)	37 ¹ / ₈ (941)	37 ¹ / ₈ (941)
H	42 ⁵ / ₈ (1082)	66 ³ / ₄ (1694)	90 ³ / ₄ (2305)	138 ⁷ / ₈ (3526)

Item	ID5SLR Merchandisers			
	4ft	6ft	8ft	12ft
A	6 ¹ / ₈ (155)			
B	58 ¹ / ₄ (1478)			
C	19 ¹ / ₈ (484)			
D	5 ¹ / ₈			
* E	12 ¹ / ₄ (309)	8 ¹ / ₈ (206)	12 ¹ / ₄ (309)	12 ¹ / ₄ (309)
* F	24 ⁷ / ₈ (631)	17 (430)	24 ⁷ / ₈ (631)	24 ⁷ / ₈ (631)
G	37 ¹ / ₈ (941)	25 ¹ / ₈ (636)	37 ¹ / ₈ (941)	37 ¹ / ₈ (941)
H	42 ⁵ / ₈ (1082)	66 ³ / ₄ (1694)	90 ³ / ₄ (2305)	138 ⁷ / ₈ (3526)

Rear Views

Double-walled telescoping doors slide both left and right

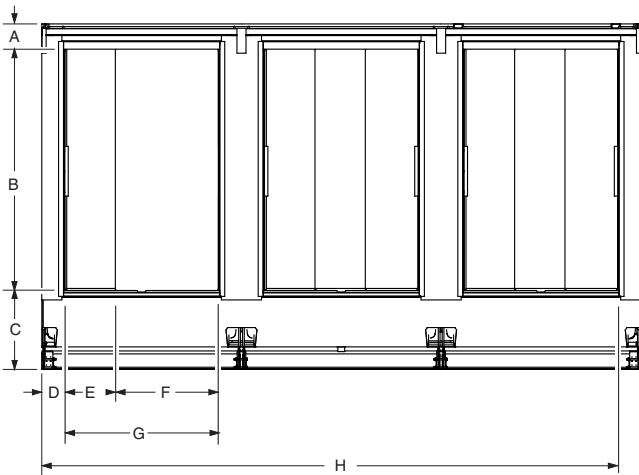

*Dimension E and F is with doors fully opened.

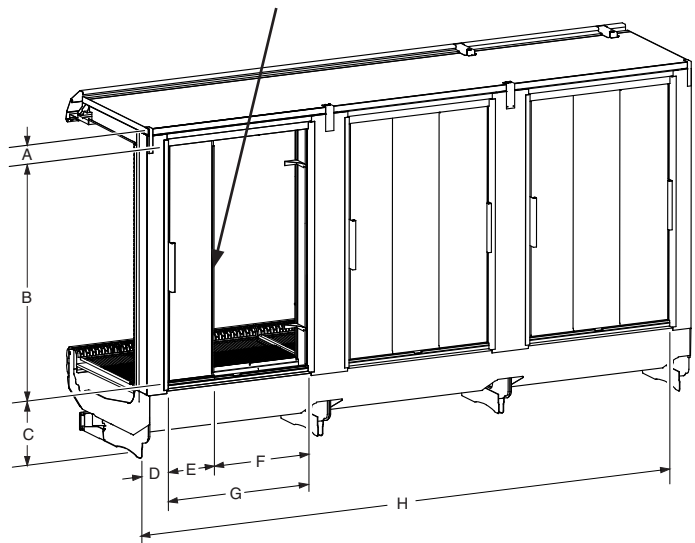

REAR VIEW DIMENSIONS **ID5SLRS**
OF CASES WITH EXTERNAL SLIDING
REAR LOADING DOORS
(4 ft, 6 ft, 8 ft, 12 ft)

Item	ID5SLRS Merchandisers			
	4 Ft	6 Ft	8 Ft	12 Ft
A	2 7/8 (74)			
B	64 1/8 (1628)			
C	16 3/8 (415)			
D	5 1/2 (139)			
E	37 1/8 (943)	25 1/8 (636)	37 1/8 (943)	37 1/8 (943)
F	11 (279)			
G	37 1/8 (943)	61 1/4 (1556)	85 1/4 (2165)	133 3/8 (3388)
H	48 1/8 (1222)	72 1/4 (1835)	96 1/4 (2445)	144 3/8 (3668)

Note: Consult Cooler Close-off Kit for instructions on connecting the merchandiser to the cooler.

Rear Views

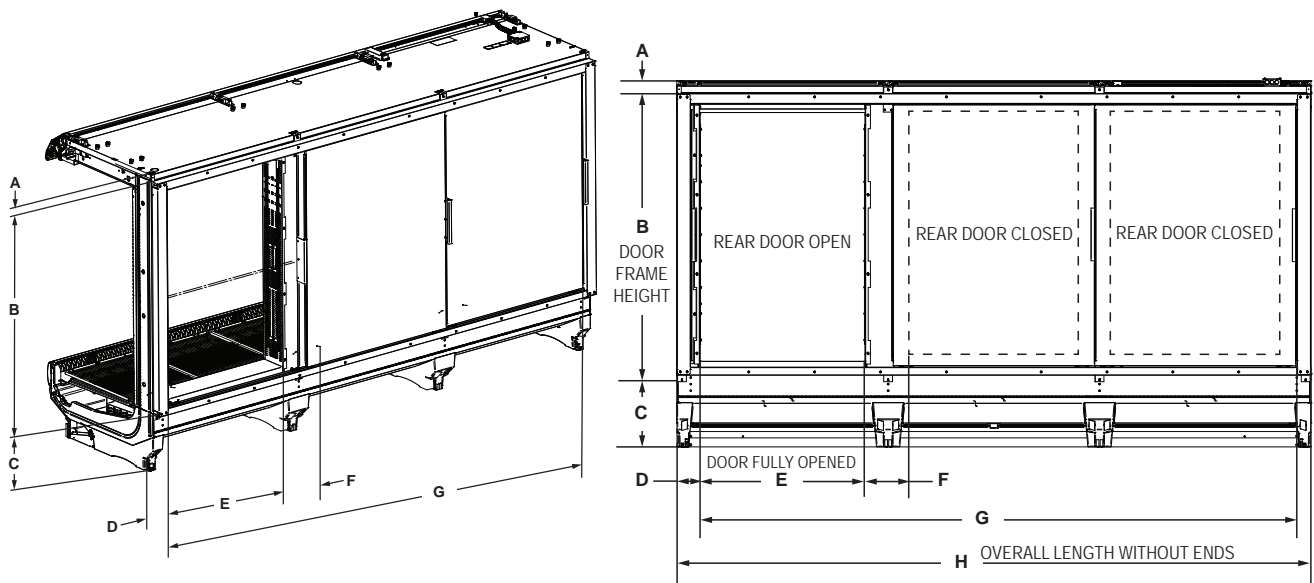

Dimensions shown as in. and (mm).

APPLY GASKETS

(Rear Load)

Refer to Pages 1-6 to 1-10.

LEGEND:

A = 1/2 x 1/2 INCH GASKET

B = NEUTRAL CURING SILICONE SEALANT

C = PIN-ALIGNMENT

D = COVER-HAND RAIL JOINT



Remove tie cable

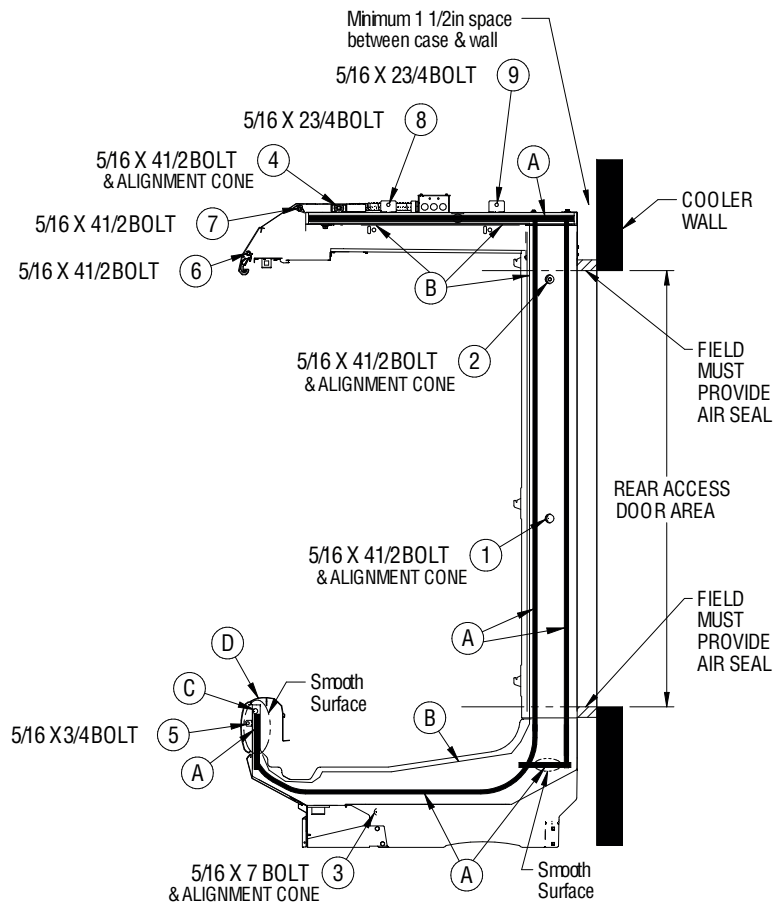

IMPORTANT:

Do not pull cases together with bolts. Cases must be moved together as close as possible Follow sequence balloons to tighten bolts.

Merchandiser case joint & end gasket to be applied on only one side of joint.

Merchandiser partition gasket to be applied on both sides of joint.

Remove end shipping braces as described on Page 1-4

Cases must be leveled as described on Page 1-5

Removed any casters - if installed

Install case lineup from left to right

Remove shelves, display racks, pans & interior back panels at the joining area

Insert gasket into case channels the entire length with no gaps

Do not stretch gasket, especially around corners

Do not butt gaskets, always overlap them

Remove paper backing after gasket has been applied

Perimeter gasket is required by NSF

Apply a continuous bead of neutral curing silicone sealant

Joints must be air tight to prevent formation of ice or condensation.

**APPLY GASKETS
(DOOR CASES)**

Case bolting details begin on the next page.
Refer to Page 1-6 for hardware list.

Do not pull cases together with bolts.
Cases must be moved together as close as possible. Follow sequence balloons to tighten bolts.

LEGEND:

- A = 1/2 x 1/2 INCH GASKET
- B = NEUTRAL CURING SILICONE SEALANT
- C = PIN-ALIGNMENT
- F = PLATE BOTTOM DOOR RAIL ALIGNMENT

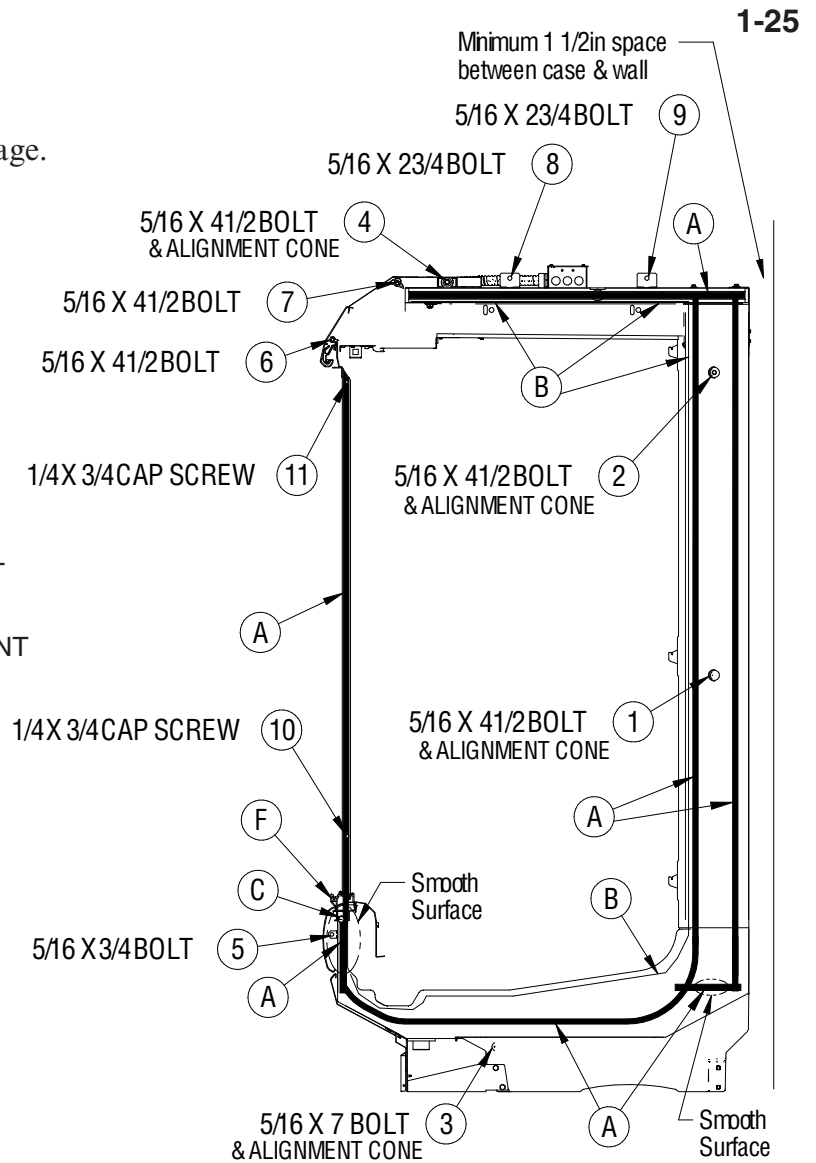

IMPORTANT:

Do not pull cases together with bolts. Cases must be moved together as close as possible. Follow sequence balloons to tighten bolts.

Merchandise case joint & end gasket to be applied on only one side of joint.

Merchandise partition gasket to be applied on both sides of joint.

Remove end shipping braces as described on Page 1-4

Cases must be leveled as described on Page 1-5

Remove any casters - if installed

Install case lineup from left to right

Remove shelves, display racks, pans & interior back panels at the joining area

Insert gasket into case channels the entire length with no gaps

Do not stretch gasket, especially around corners

Do not butt gaskets, always overlap them

Remove paper backing after gasket has been applied

Perimeter gasket is required by NSF

Apply a continuous bead of neutral curing silicone sealant

Joints must be air tight to prevent formation of ice or condensation.

**CASE JOINING
(DOOR & REAR LOAD CASES)
CONTINUED**

LEGEND:

C=PIN-ALIGNMENT

F=PLATE-BOTT DOOR RAIL ALIGNMENT

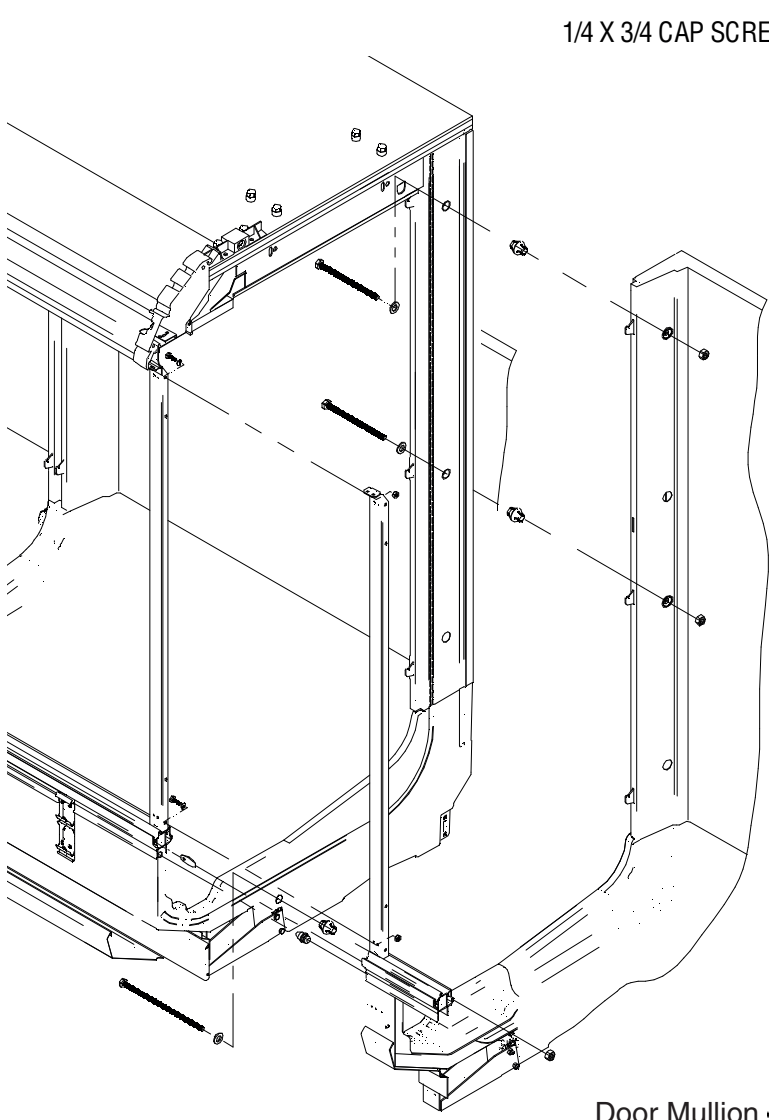

1/4 X 3/4 CAP SCREW (11)

5/16 X 4 1/2 BOLT & ALIGNMENT CONE (2)

1/4 X 3/4 CAP SCREW (10)

5/16 X 4 1/2 BOLT & ALIGNMENT CONE (1)

(F)

(C)

5/16 X 7 BOLT & ALIGNMENT CONE (3)

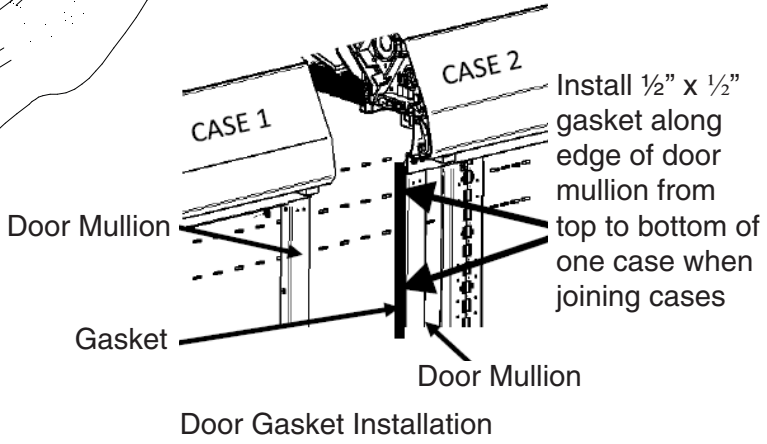

CASE JOINING (DOOR & REAR LOAD CASES)

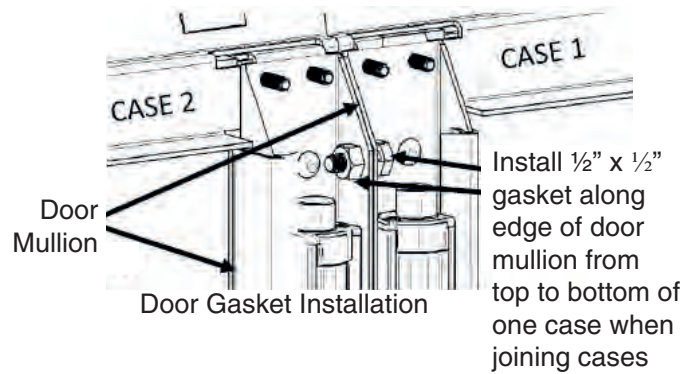
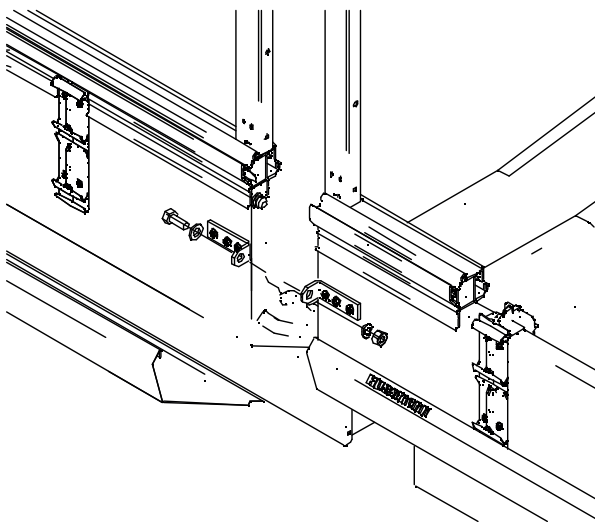
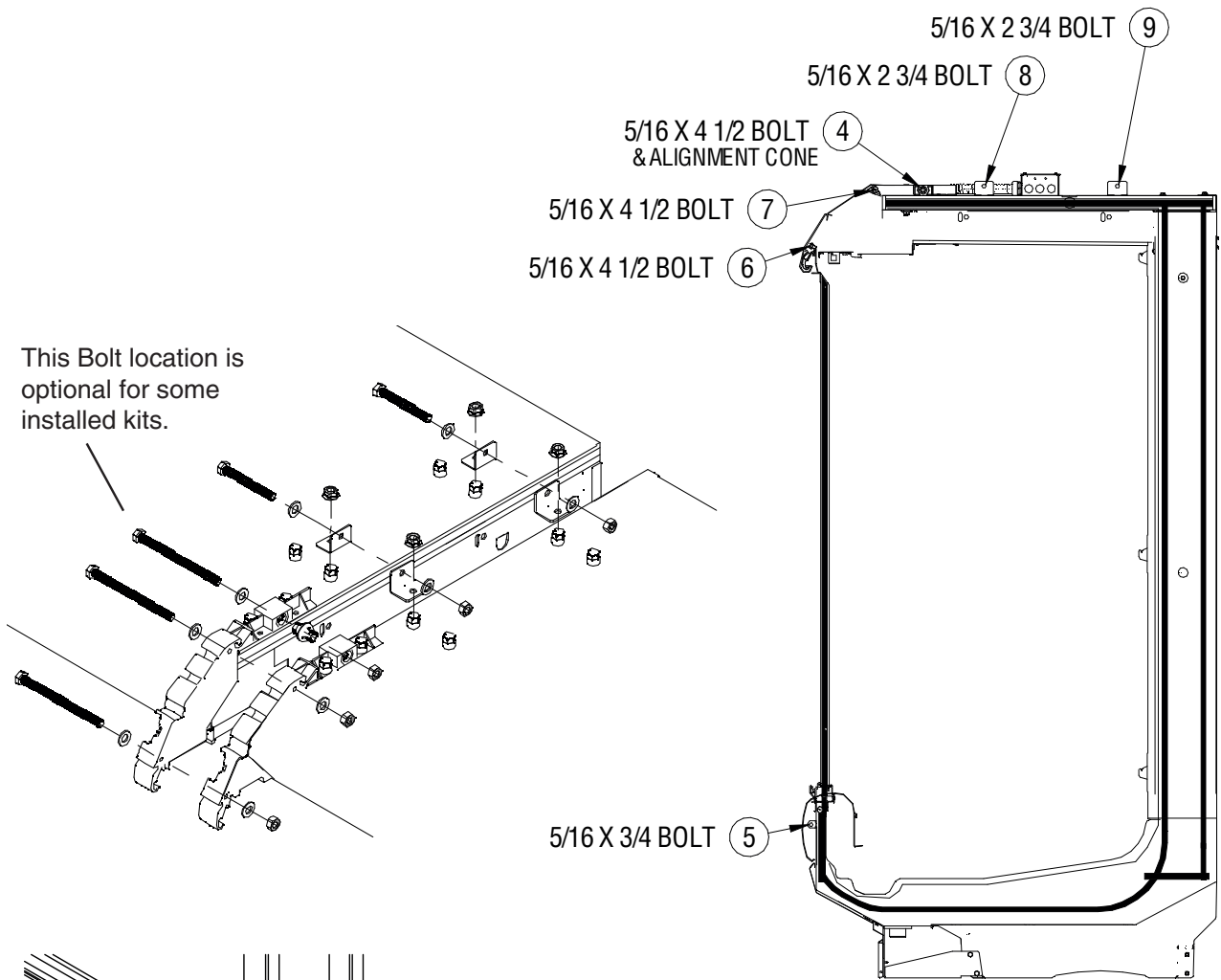

**DOORS
(INSTALLING, REMOVING, ADJUSTING)**

A. To install a door:
Lean door back, and push pin into mullion.
Ensure push pins are fully seated in canopy support bracket.

B. To remove a door:
Raise door up and lift rod bottom out of
bottom hinge plate hole

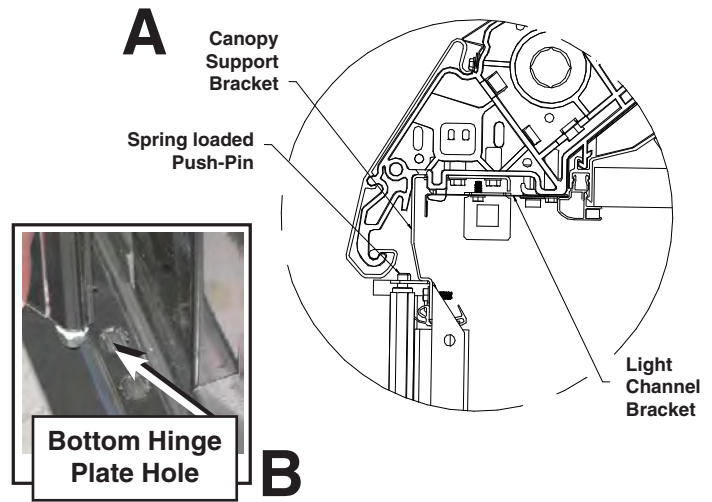

ADJUSTING ECOVISION DOORS

Check that all doors open and close properly.

Excessive ambient conditions may cause condensation and therefore sweating of doors. Facility operators should monitor doors and floor conditions to ensure safety of persons.

A. Leveling — Merchandisers must be installed level to ensure proper operation of the refrigeration system, and to ensure proper drainage of defrost water.

B. Door Adjustment — Loosen the screws A, B and C as shown below (Do not remove the screws completely).

Glass alignment is also affected with improper leveling of the merchandisers. All steps of setting joining and case leveling attention to the glass position is critical. Do not attempt to make glass adjustments prior to case leveling.

Slide the bottom plate left and right until proper alignment is achieved. Retighten the screws A, B and C. Install fasteners in locations 1 and 2 as shown below.

EcoVision Door Alignment - Modular Bottom Hinge Plate

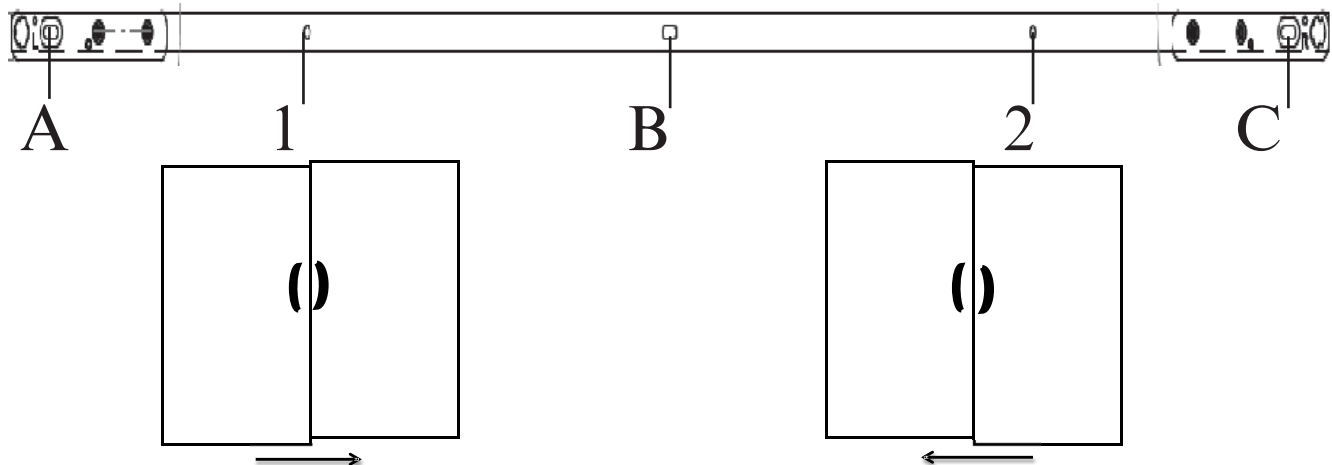

To Correct Shift the Bottom Plate to the Right

To Correct Shift the Bottom Plate to the Left

ADJUSTING DOOR CLOSING SPEED

The door's closing speed is factory adjusted, but the door may also be field adjusted.

Do the following to adjust the doors:

1. To release door tension, open the door to 90° and lift up the door from the bottom. Lift the torsion rod out of the star pattern in the bottom hinge plate. (The door should be lifted out of the star pattern in the hinge plate to prevent any damage to the star pattern.)
2. Use a ½ in. open end wrench to tighten the torsion of the door. Adjust tension with each audible click. Doors should be adjusted to 4 clicks, more if needed. Door must be properly resealed in star pattern of hinge plate after torsion tension is applied.

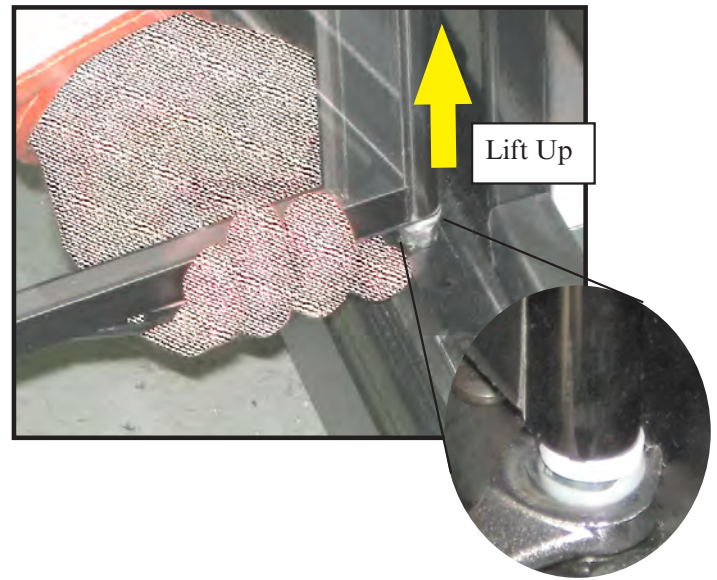

REPLACING LED VERTICAL MULLION LIGHT BARS

LED vertical mullion lights are an available lighting option for EcoVision doors. Center fixtures illuminate the middle of the case, and the end fixtures illuminate the ends, or sides of the case.

The light bars are attached to the door mullions with mounting clips, and can be replaced similar to the canopy lights — just remove them from the mounting clips, and connect new wires at quick connect.

These LEDs have different shaped lenses. They are not to be interchanged. Contact your Hussmann representative to order replacements.

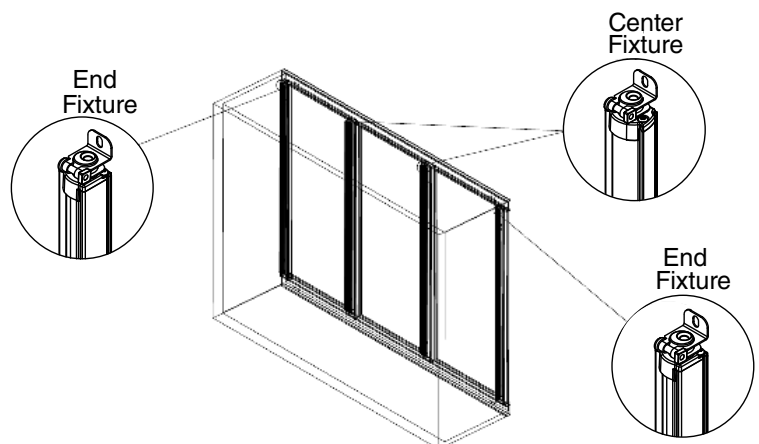

















INSTALLING END ASSEMBLIES

Remove shipping brace. Brace screws will be replaced with shorter screws found in packout kit. Ensure Nut Retainers are in place. Apply Gaskets and Silicone to End Frame.

Apply 1/2 x 1/2 in. (12.7 mm) x (12.7 mm) gaskets into the case channels. Check that the gasket is properly inserted into the entire length of the channels with no gaps. Apply silicone between case end cap and end.

FIELD INSTALLED HARDWARE	Multi Deck Qty/Each	Convertible Qty/Each	Single Deck Qty/Each	View End Multi Deck Qty/Each
Description				
SEALER SILICONE ADHESIVE	1	1	1	1
GASKET 1/2 X 1/2 X 180	1	1	1	1
SCREW SM 10-16X3/4 HX WASHER	1	1	1	N/A
BOLT 5/16 x 2 3/4 GRADE 5 ZINC PLATED TAP*	4	2	1	5
BOLT- TAP, 5/16 x 4 1/2, STEEL, ZINC FINISH, GR5	1	1	1	1
WASHER-FLAT 5/16" ZINC*	7	4	2	8
NUT-HEX 5/16 STEEL ZINC FINISH GRADE 8*	3	2	2	4
NUT-PUSH 5/16" RETAINER STEEL ZINC*	2	1	1	2
NUT-J RETAINER 5/16"	2	1	N/A	2
BUTTON-PLUG 7/8 DIA*	5	3	2	6

*Quantities may vary depending on which type of end is to be placed on case.

- Screw-sm #10 x 3/4 Hex Washer  
- Bolt-5/16 x 2 3/4  
- Bolt-5/16 x 4 1/2  
- Washer Flat-5/16  
- Nut Hex-5/16  
- Nut-Push 5/16  
- Nut-J Retainer  
- Button-Plug  

IMPORTANT:

Do not pull cases together with bolts. Cases must be moved together as close as possible. Follow sequence balloons to tighten bolts.

Apply case end gasket to only one side of case joint.

Remove end shipping braces as described on Page 1-4.

Cases must be leveled as described on Page 1-5.

Removed any casters - if installed.

Install case lineup from left to right.

Remove shelves, display racks, pans & interior back panels at the joining area.

Insert gasket into case channels the entire length with no gaps.

Do not stretch gasket, especially around corners.

Do not butt gaskets, always overlap them.

Remove paper backing after gasket has been applied.

Perimeter gasket is required by NSF.

Apply a continuous bead of neutral curing silicone sealant.

Joints must be air tight to prevent formation of ice or condensation.

CASE VIEW END INSTALLATION MULTI-DECK (REAR-LOAD & DOOR)

Refer to detail views

LEGEND:

A = 1/2 x 1/2 INCH GASKET

B = NEUTRAL CURING SILICONE SEALANT

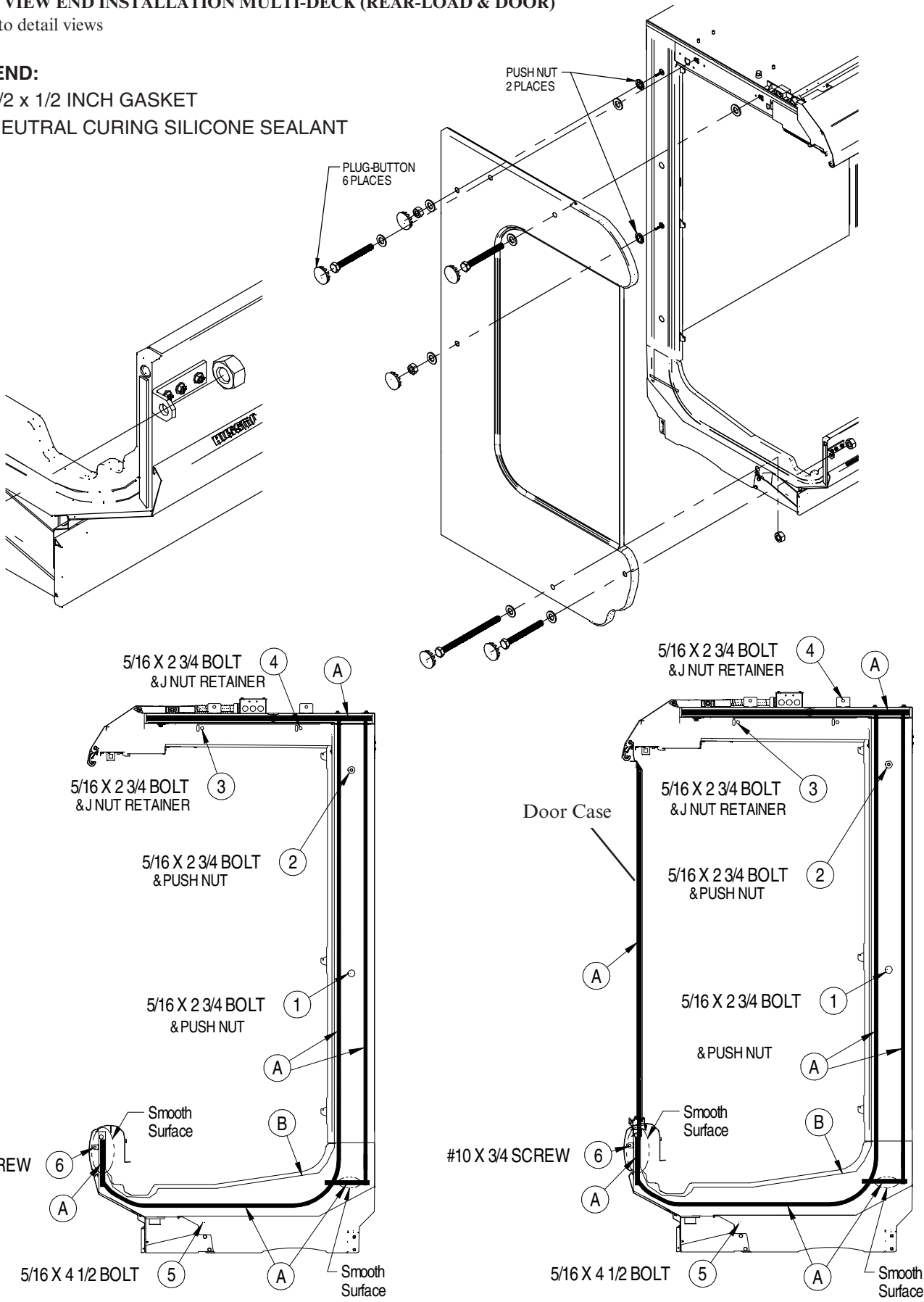

CONVERTIBLE CASE END INSTALLATION

Refer to detail views

LEGEND:

A = 1/2 x 1/2 INCH GASKET

B = NEUTRAL CURING SILICONE SEALANT

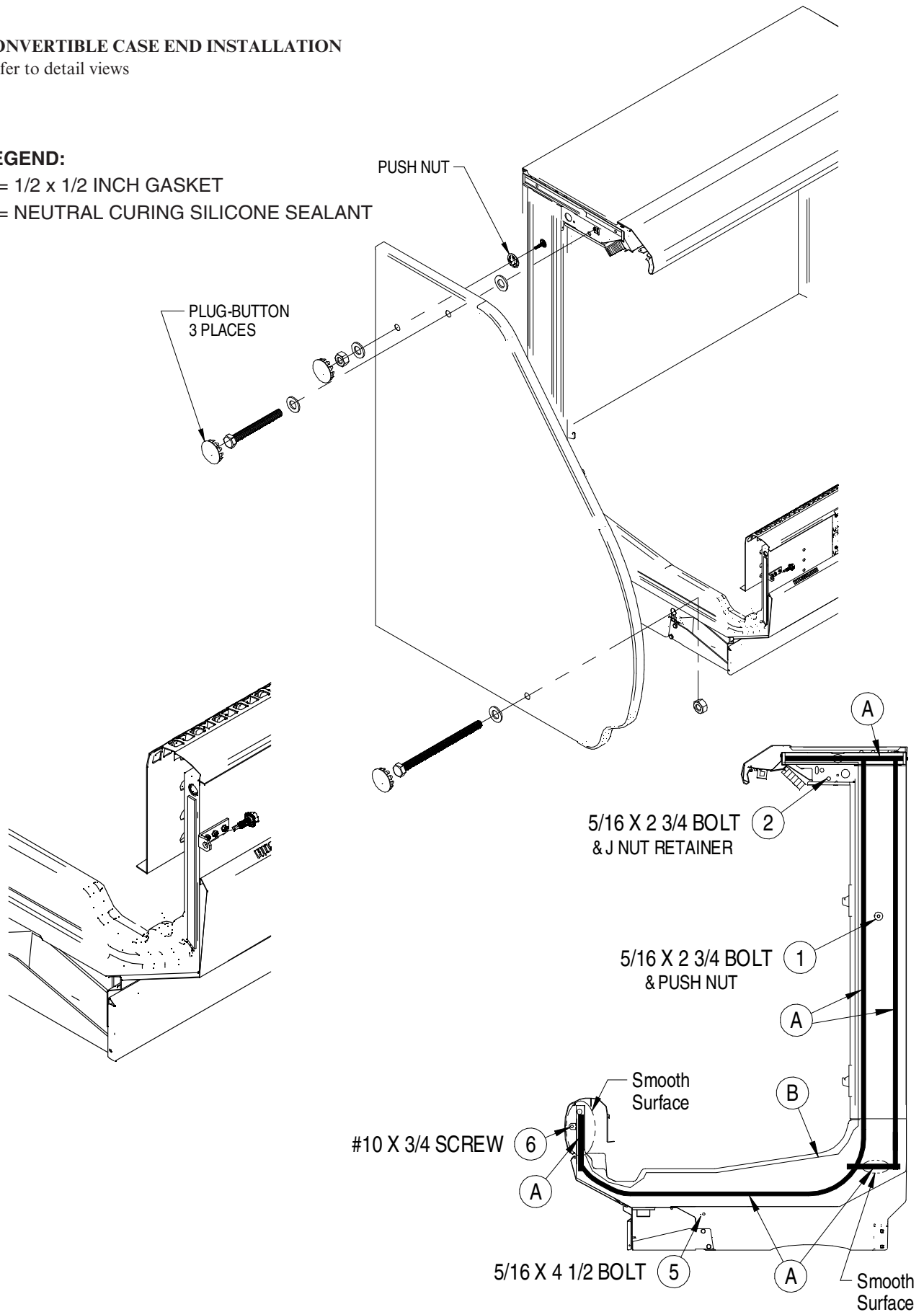

SINGLE DECK CASE END INSTALLATION

Refer to detail views

LEGEND:

A = 1/2 x 1/2 INCH GASKET

B = NEUTRAL CURING SILICONE SEALANT

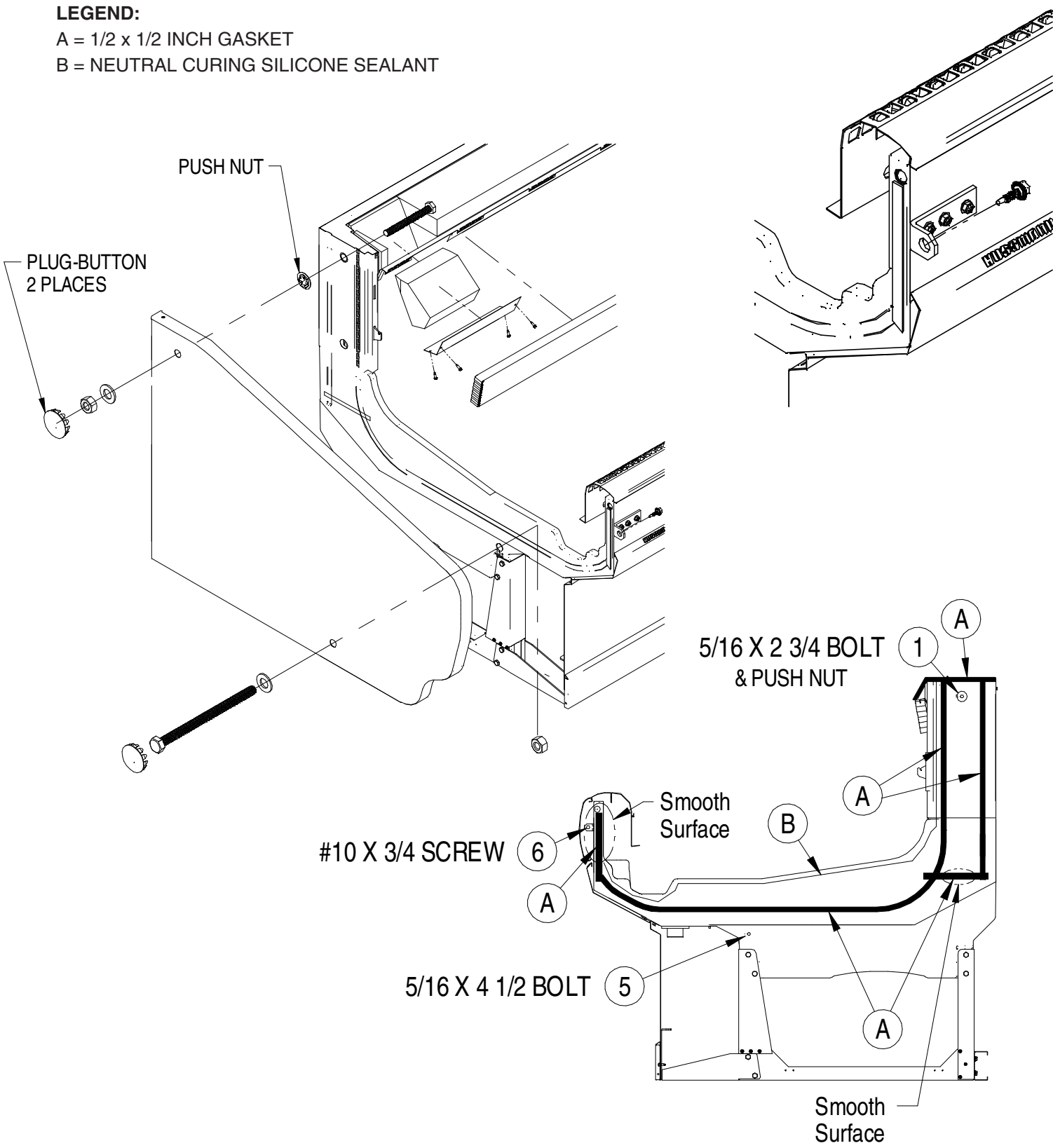















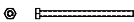





PARTITION HARDWARE

Remove shipping brace. Brace screws will be replaced with shorter screws found in packout kit. Ensure Nut Retainers are in place. Apply Gaskets and Silicone to End Frame.

Apply ½ x ½ in. (12.7 mm) x (12.7 mm) gaskets into the case channels. Check that the gasket is properly inserted into the entire length of the channels with no gaps. Apply silicone between case end cap and end.

Description	Alt Canopy Applications	Multi Deck/Door Same Case Qty/ Each	Multi Deck/Door Different Case Qty/ Each	Convertible Different Case Qty/ Each
SEALER SILICONE ADHESIVE	Refer to Multi Deck Different Case	2	2	2
GASKET 1/2 X 1/2 X 180	Refer to Multi Deck Different Case	2	2	2
SCREW-SHEET METAL #8 X 5/8 PHIL HX HD	3 or 4	1	1	1
SCREWSM10-16X3/4 HX WASHER	1	2	2	2
BOLT HEX 1/4 x 1 1/2	Refer to Multi Deck Different Case	N/A	2	N/A
BOLT HEX 1/4 x 2 1/4*	1	N/A	2	2
BOLT HEX 1/4 x 4.0	Refer to Multi Deck Different Case	N/A	1	N/A
BOLT HEX 5/16 x 2 3/4*	Refer to Multi Deck Different Case	1	4	2
BOLT-HEX 5/16 x 4 1/2	Refer to Multi Deck Different Case	2	1	N/A
BOLT-HEX 5/16 x 7.0*	Refer to Multi Deck Different Case	2	N/A	N/A
BOLT-HEX 5/16 x 8.0	Refer to Multi Deck Different Case	1	N/A	1
WASHER-FLAT 1/4*	1	N/A	5	2
WASHER-FLAT 5/16*	Refer to Multi Deck Different Case	8	5	4
NUT-HEX 5/16*	Refer to Multi Deck Different Case	7	3	4
NUT-HEX 3/8-24 SERRATED FLANGE	1	4	2	N/A
NUT-PUSH5/16* RETAINERSTEEL ZINC*	Refer to Multi Deck Different Case	2	N/A	N/A
NUT-J RETAINER5/16*	Refer to Multi Deck Different Case	1	2	1
BRACKET-CASE JOINING	N/A	4	2	N/A
BRACKET-CANOPY (ALT APPLICATIONS)	1	N/A	N/A	N/A
BRACKET-UNIBODY (ALT APPLICATIONS)	1	N/A	N/A	N/A
BUTTON-PLUG7/8 DIA*	Refer to Multi Deck Different Case	N/A	2	1
BRACKET-CLOSEOFF SPLASHGUARD	Refer to Multi Deck Different Case	1	1	1
CLOSEOFF-SPLASHGUARD	Refer to Multi Deck Different Case	1	1	1

*Quantities may vary depending on which type of end is to be placed on case.

- Screw-Sheet Metal #8 x 5/8 
- Screw-sm #10 x 3/4 Hex Washer 
- Bolt-1/4 x 1 1/2 
- Bolt-1/4 x 2 1/4 
- Bolt-1/4 x 4 
- Bolt-5/16 x 2 3/4 
- Bolt-5/16 x 4 1/2 
- Bolt-5/16 x 7 
- Bolt-5/16 x 8 
- Washer Flat-1/4 
- Washer Flat-5/16 
- Nut Hex-5/16 
- Nut Hex-3/8 Serr Flange 
- Nut-Push 5/16 
- Nut-J Retainer 
- Bracket-Case Joining 
- Bracket-Canopy (Alt Applications) 
- Bracket-Unibody (Alt Applications) 
- Button-Plug 
- Bracket-Closeoff Splashguard 
- Closeoff-Splashguard 

IMPORTANT:

Do not pull cases together with bolts. Cases must be moved together as close as possible. Follow sequence balloons to tighten bolts.

Apply case end gasket to only one side of case joint.

Remove end shipping braces as described on Page 1-4.

Cases must be leveled as described on Page 1-5.

Removed any casters - if installed.

Install case lineup from left to right.

Remove shelves, display racks, pans & interior back panels at the joining area.

Insert gasket into case channels the entire length with no gaps.

Do not stretch gasket, especially around corners.

Do not butt gaskets, always overlap them.

Remove paper backing after gasket has been applied.

Perimeter gasket is required by NSF.

Apply a continuous bead of neutral curing silicone sealant.

Joints must be air tight to prevent formation of ice or condensation.

1-36

**MULTI DECK (REAR LOAD & DOOR)
SAME CASE PARTITIONS**

Refer to detail views

LEGEND:

A = 1/2 x 1/2 INCH GASKET

B = NEUTRAL CURING SILICONE SEALANT

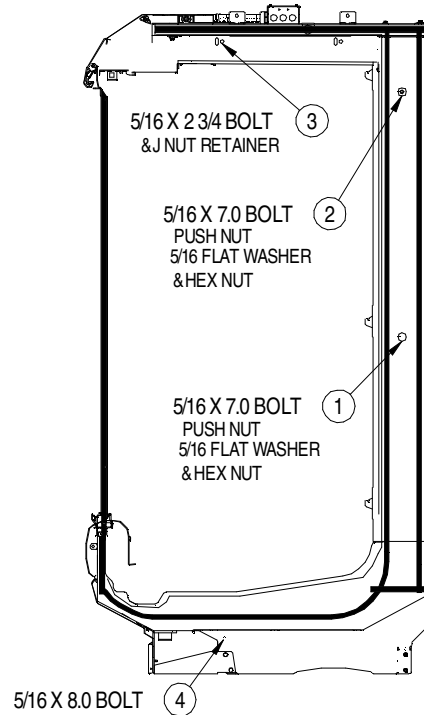
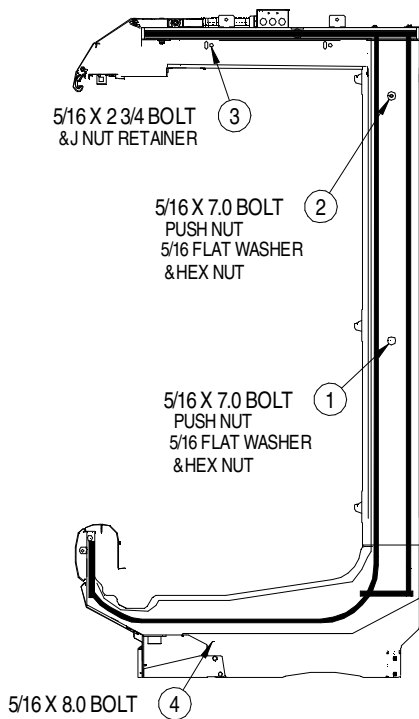
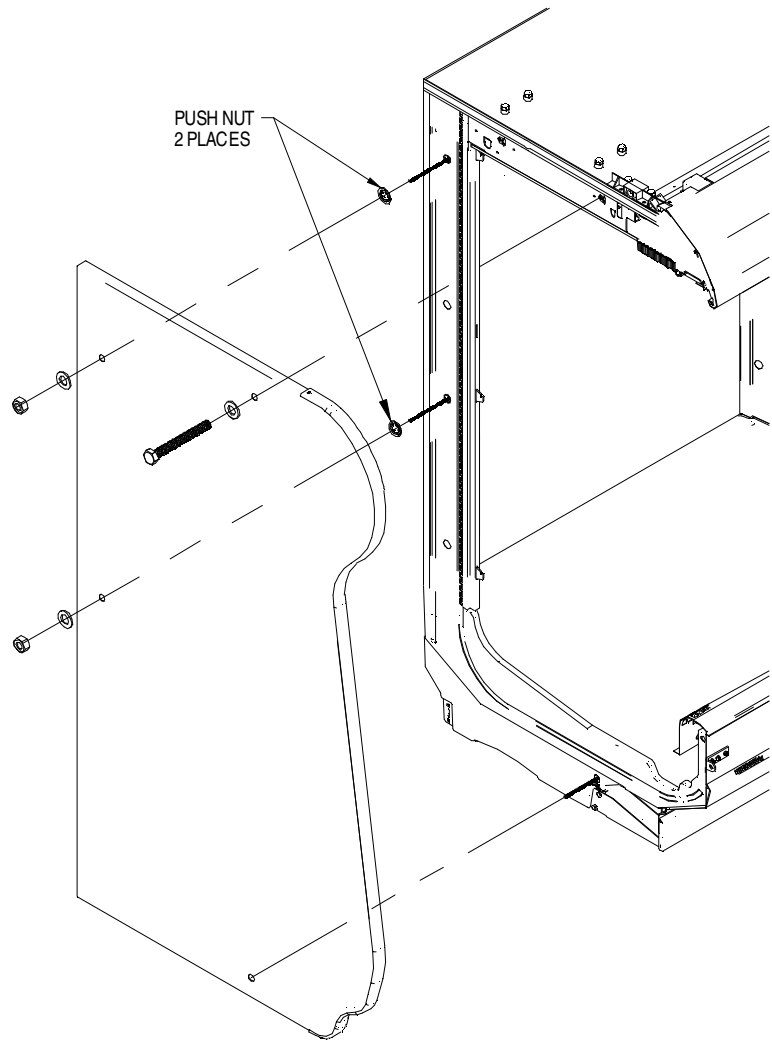

**MULTI DECK (REAR-LOAD & DOOR)
SAME CASE PARTITIONS CONTINUED**

Refer to detail views

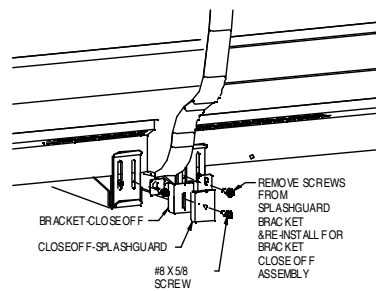
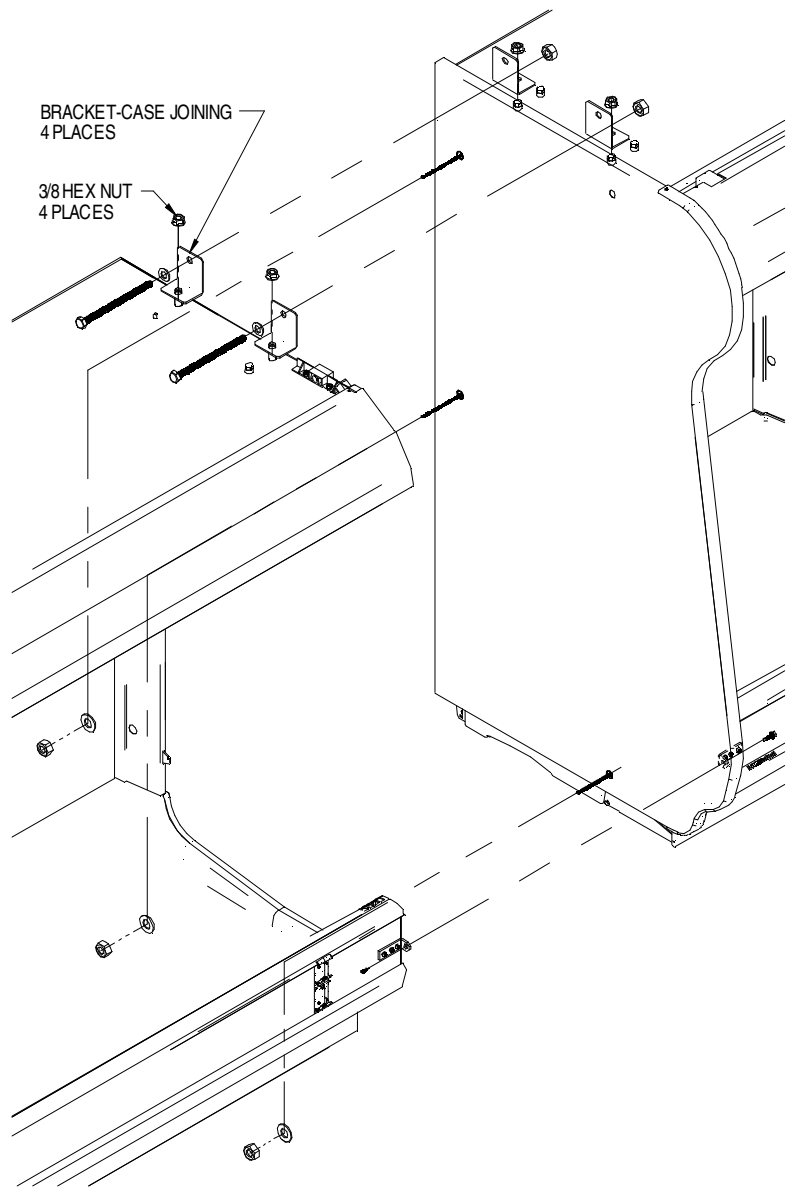
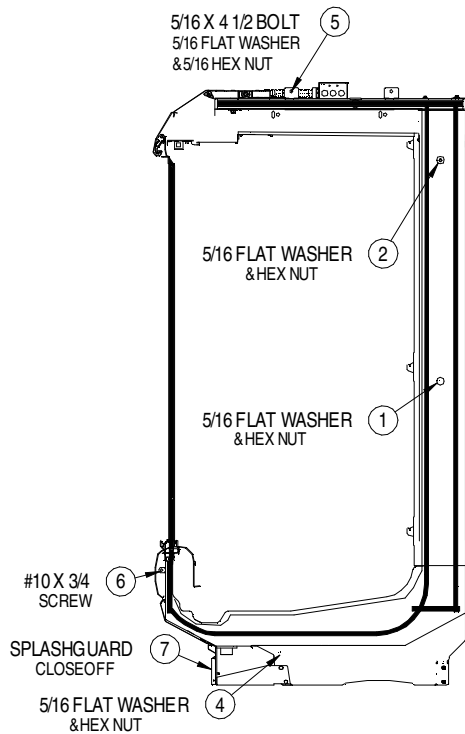
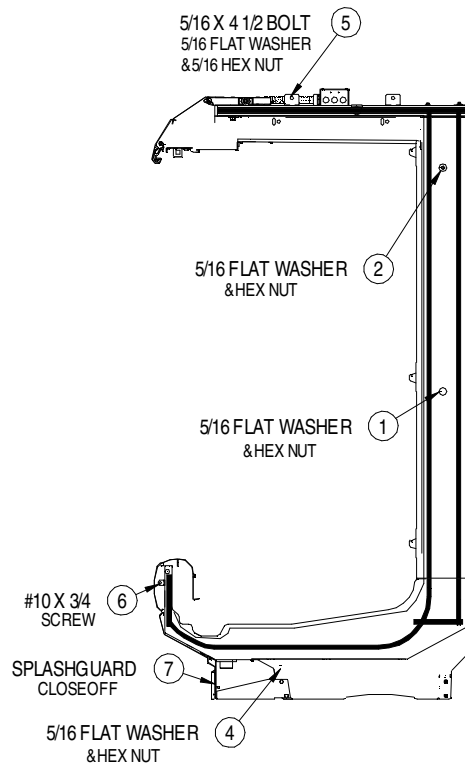

**MULTI DECK (REAR-LOAD & DOOR)
DIFFERENT CASE PARTITIONS**

Refer to detail views

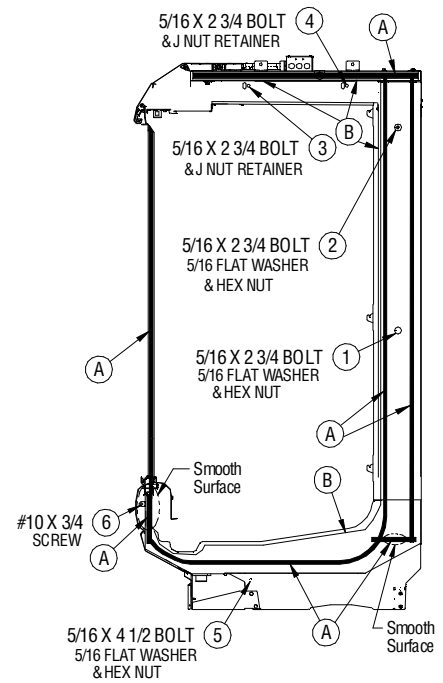
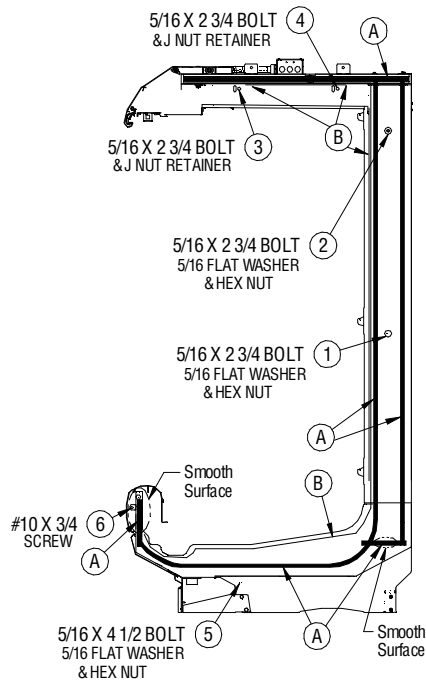
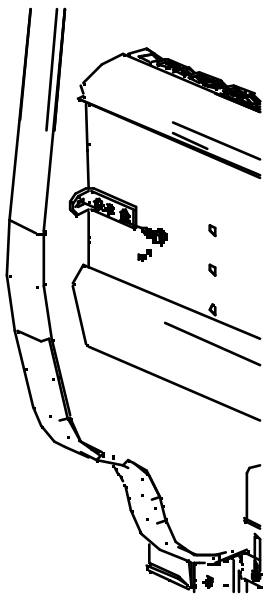
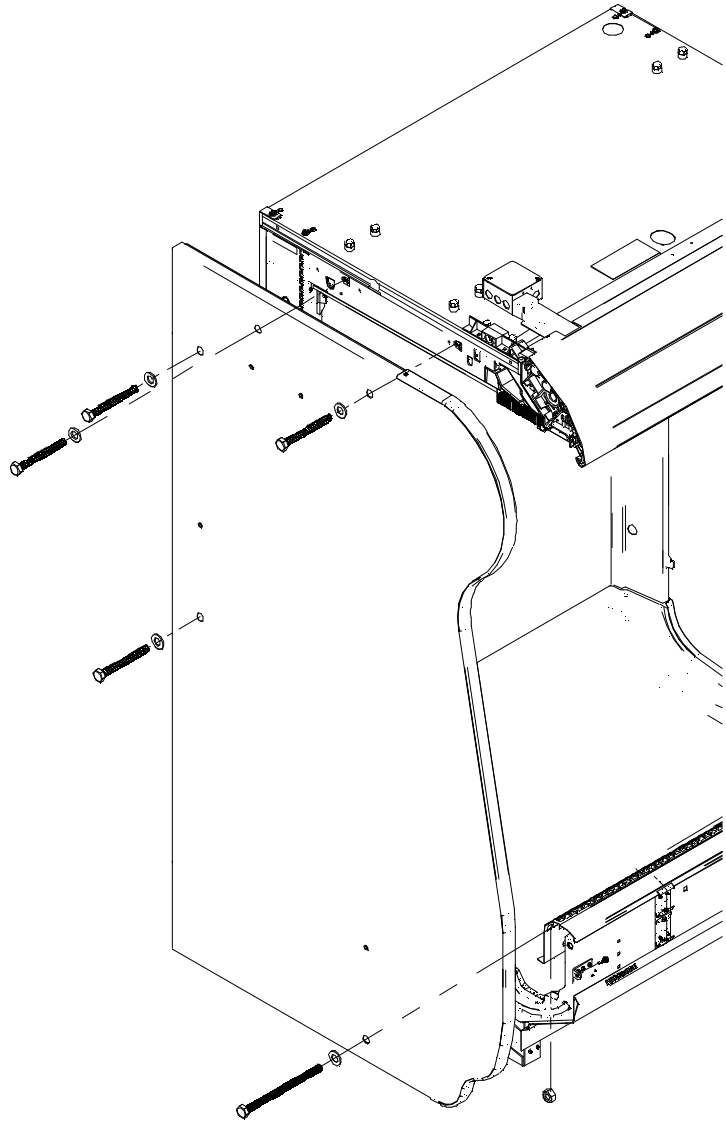
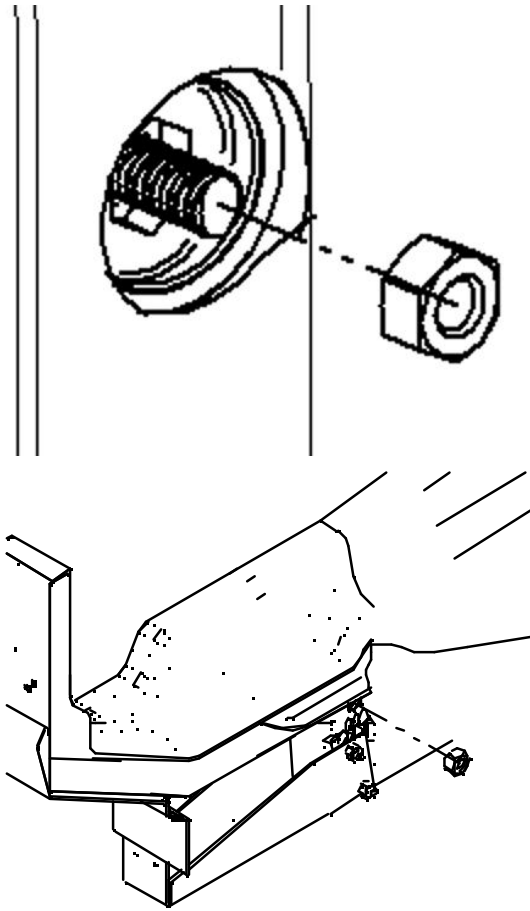

**MULTI DECK (REAR-LOAD & DOOR)
DIFFERENT CASE PARTITIONS
CONTINUED**

Refer to detail views

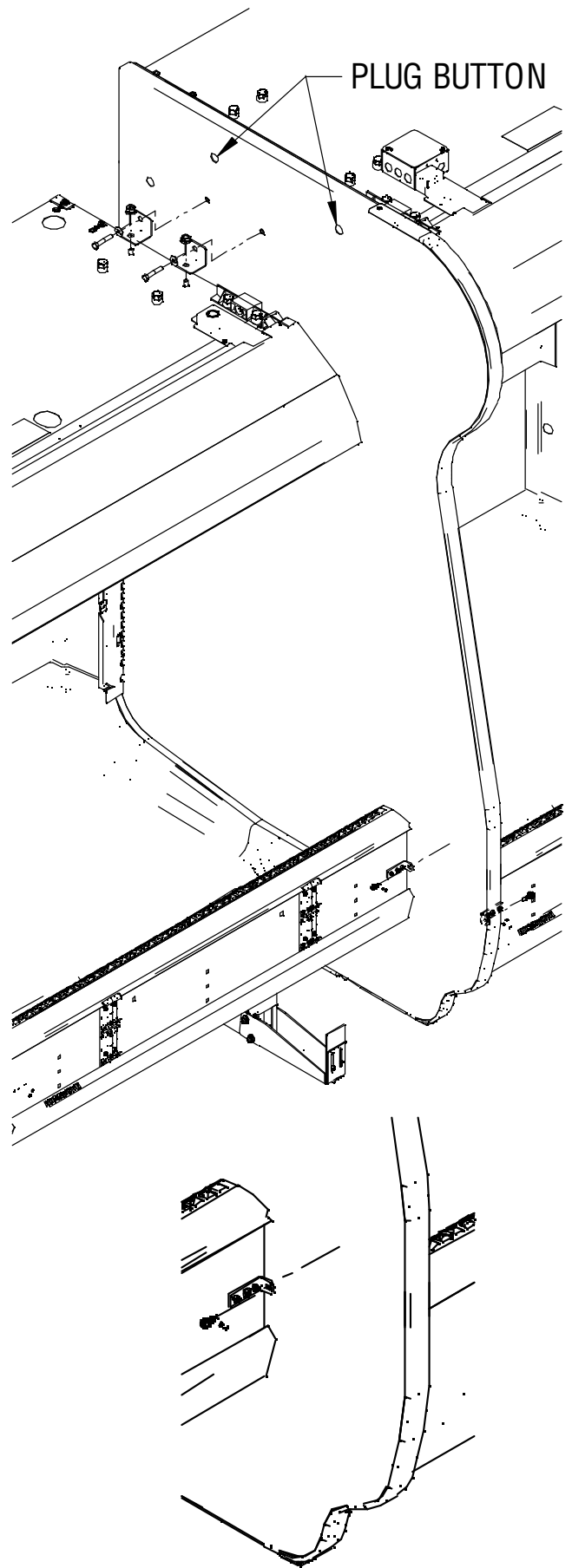
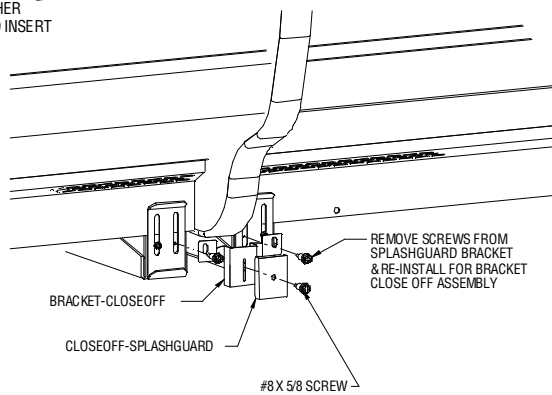
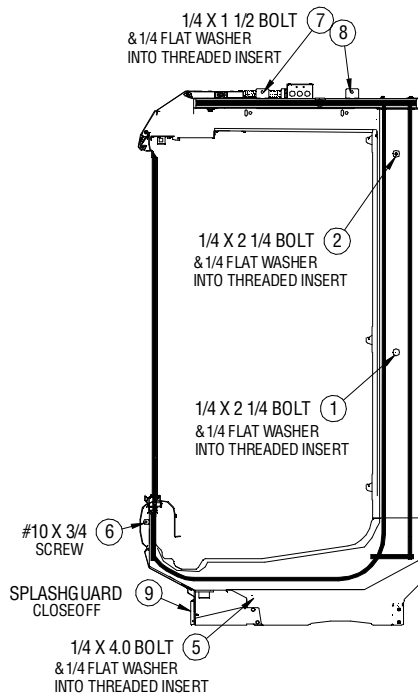
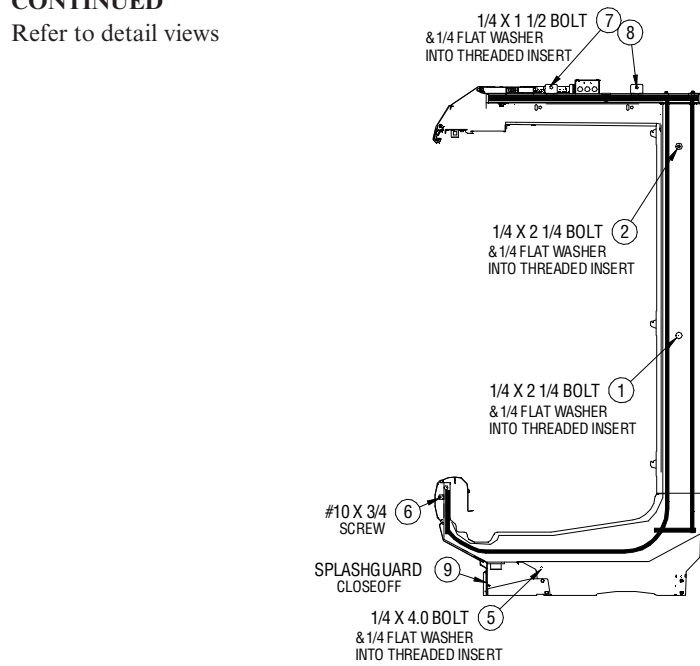

DIFFERENT CASE PARTITIONS MULTI-DECK (REAR-LOAD & DOOR)
ALTERNATIVE CANOPY APPLICATIONS
CONTINUED

Refer to detail views

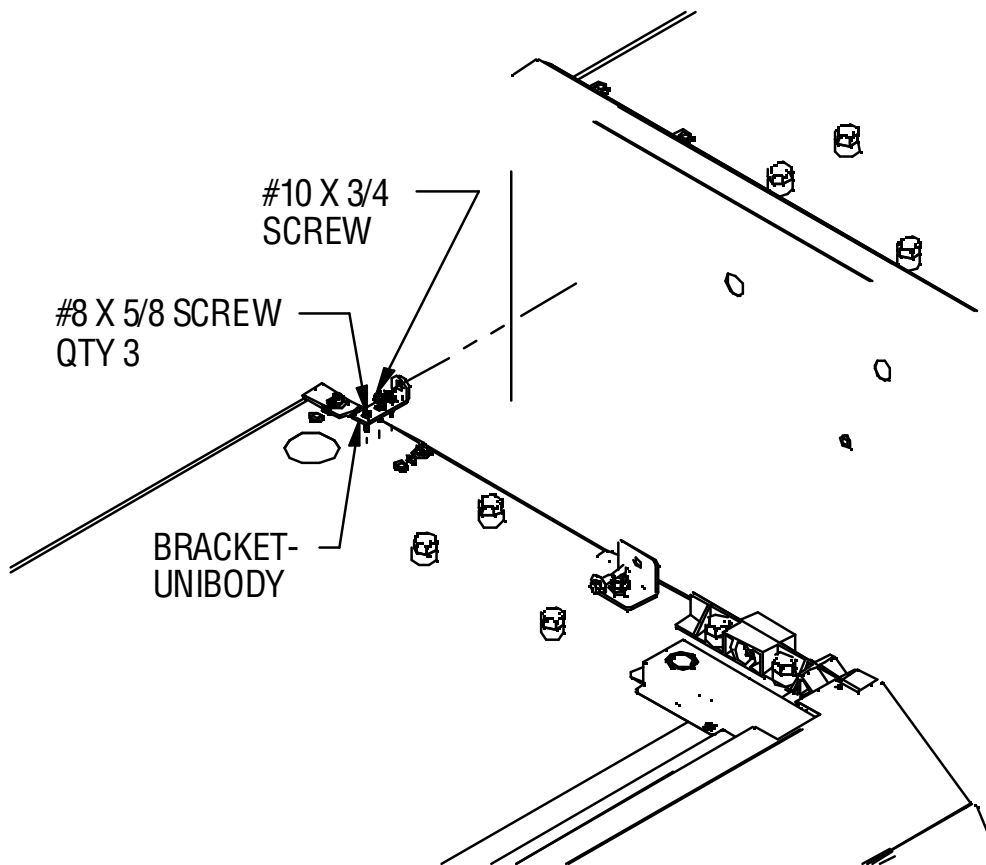
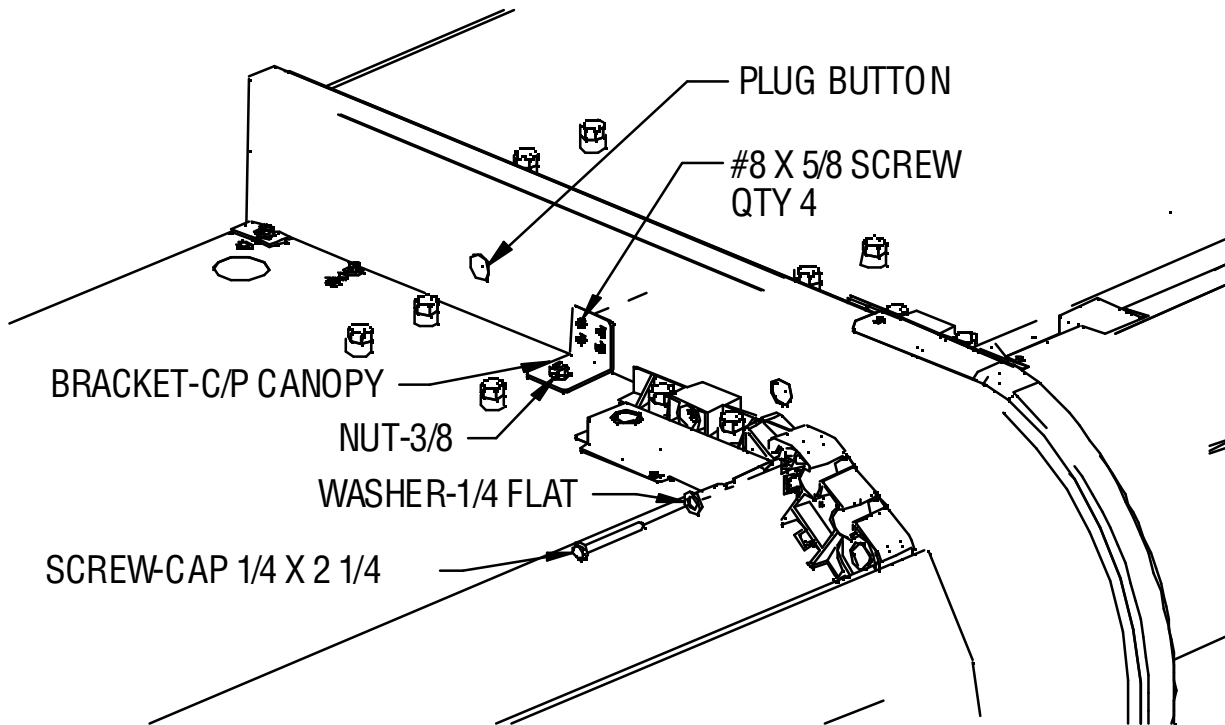

CONVERTIBLE DIFFERENT CASE PARTITIONS

Refer to detail views

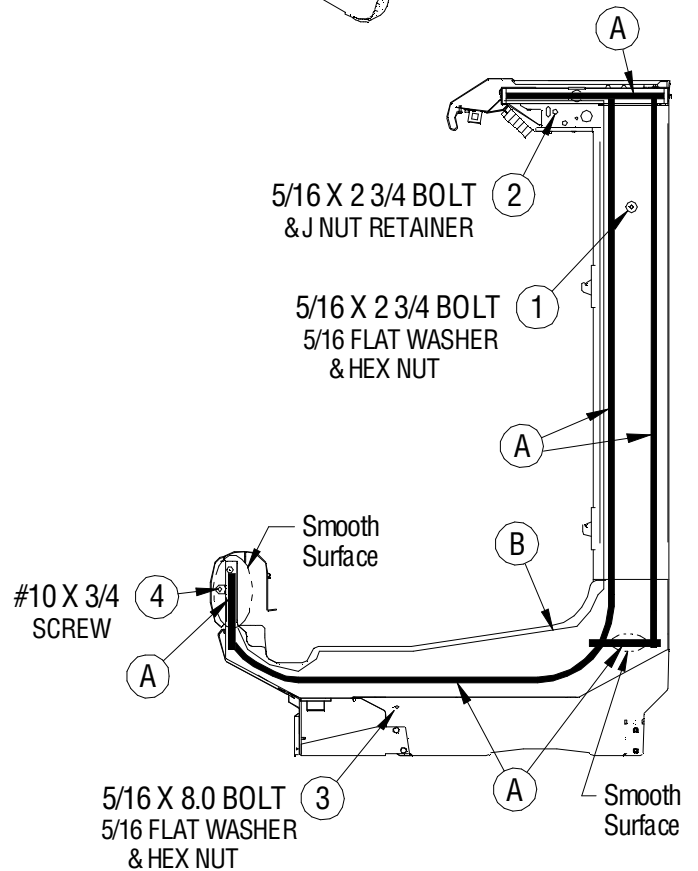
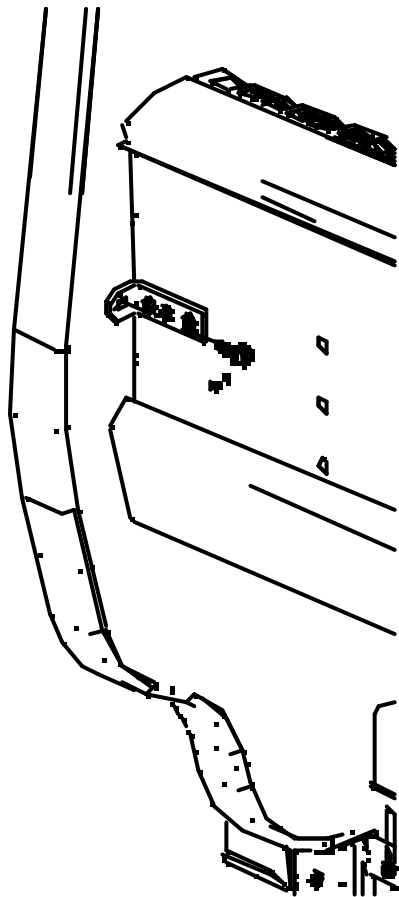
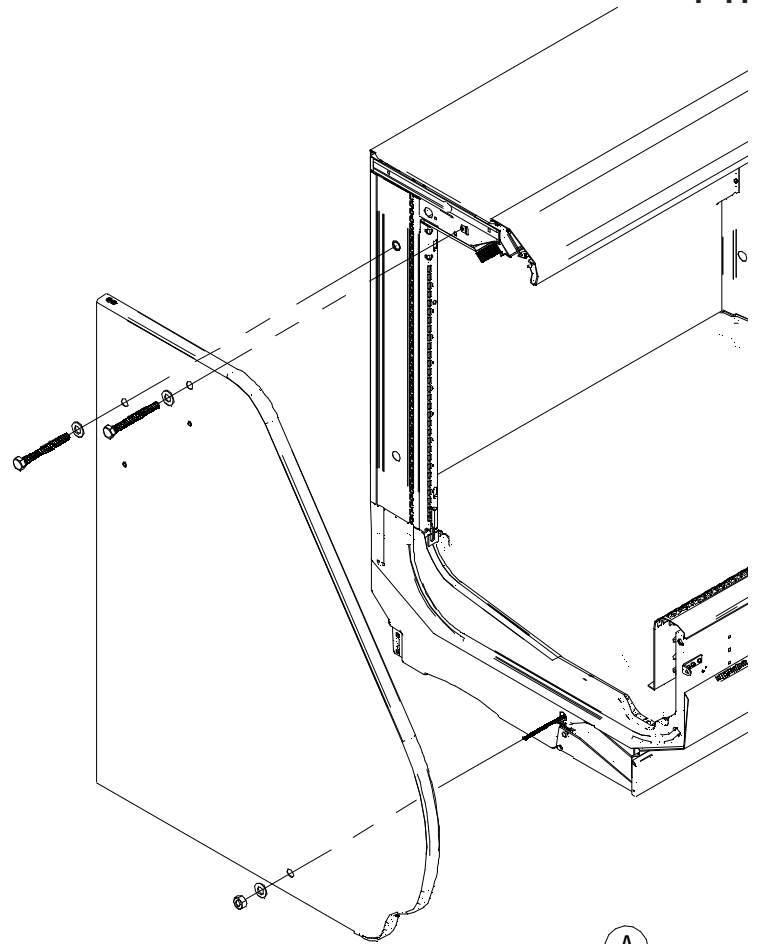
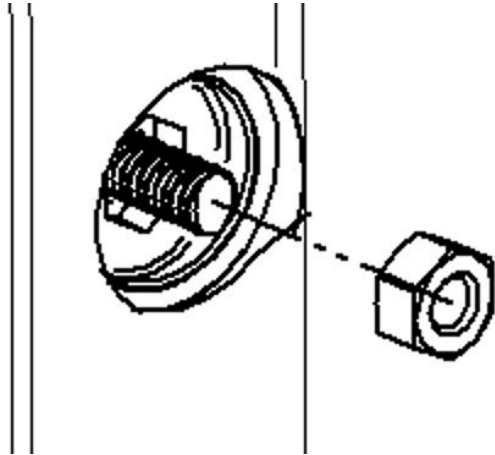

CONVERTIBLE DIFFERENT CASE PARTITIONS
CONTINUED

Refer to detail views

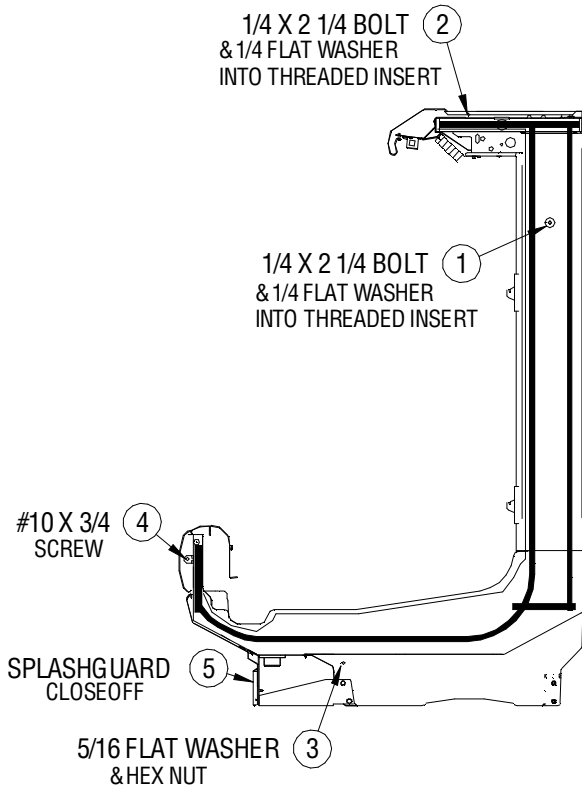

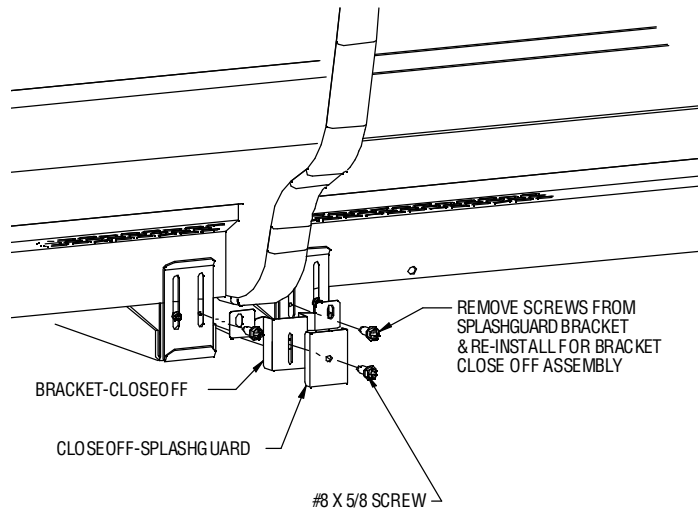
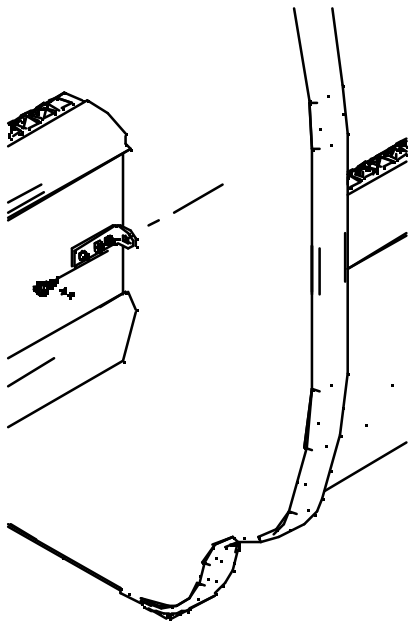
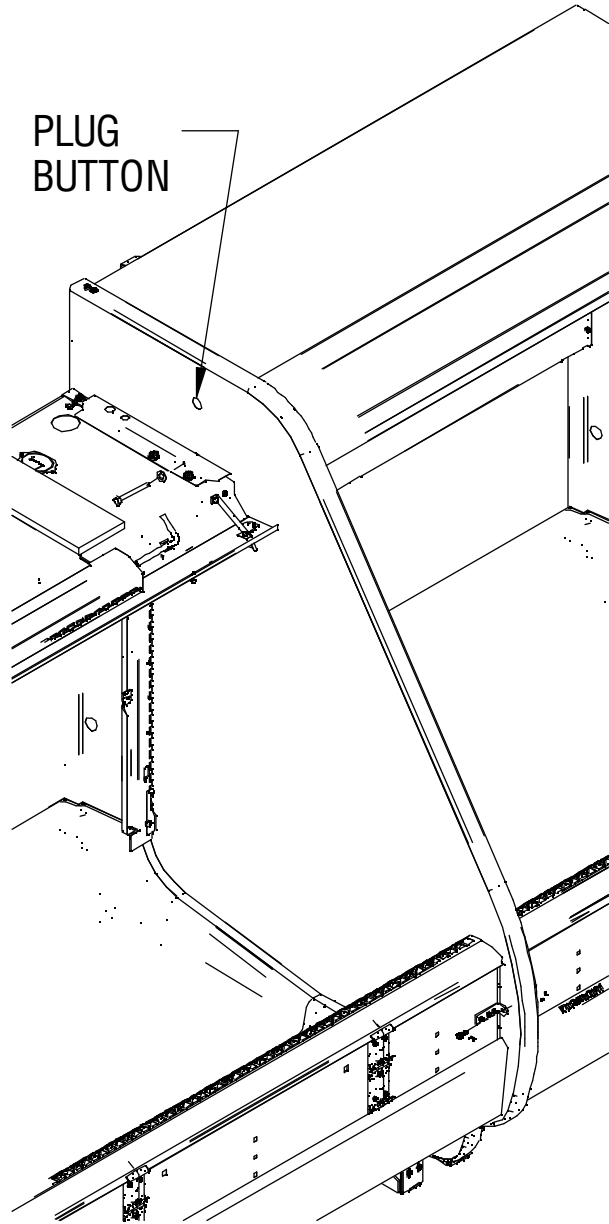

PLUG
BUTTON



ACRYLIC PARTITION HARDWARE

Description	Multi Deck Qty/Each	Convertible Qty/Each
PARTITION-ACRYLIC	1	1
BRACKET-CANOPY	1	1
BRACKET-RETURNAIRGRILL	N/A	1
SCREWSM#8 x 5/8 HEX	3	4
SCREWMACHINE#8 x 1/2 PHILL	3	4
LOCKWASHER-#8 EXT TOOTH	3	4
NUT-#8 MACHINEHEX	3	4

Screw-Sheet Metal #8 x 5/8  

Screw-Machine #8 x 1/2 Phill  

Lockwasher-Ext Tooth #8  

Nut Machine Hex-#8  

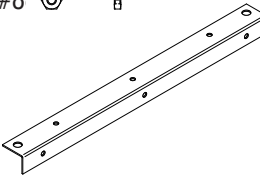
Bracket-Canopy Multideck 

Bracket-Canopy Convertible 

Bracket-Return Air Grill 

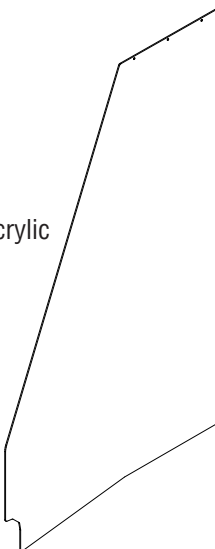
Partition-Acrylic 

MULTI-DECK
ACRYLIC PARTITIONS
Refer to detail views

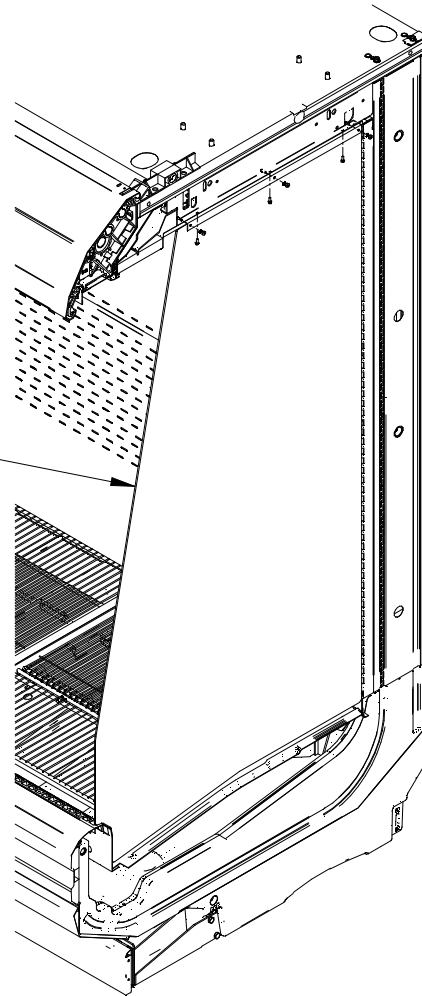

ACRYLIC PARTITION
TO BE MOUNTED
BETWEEN TWO
CASES ATTACH
BRACKET TO ONLY
ONE CASE

#8 X 1/2 MACHINE SCREW
#8 EXT TOOTH LOCKWASHER
& #8 MACHINE NUT
3 PLACES

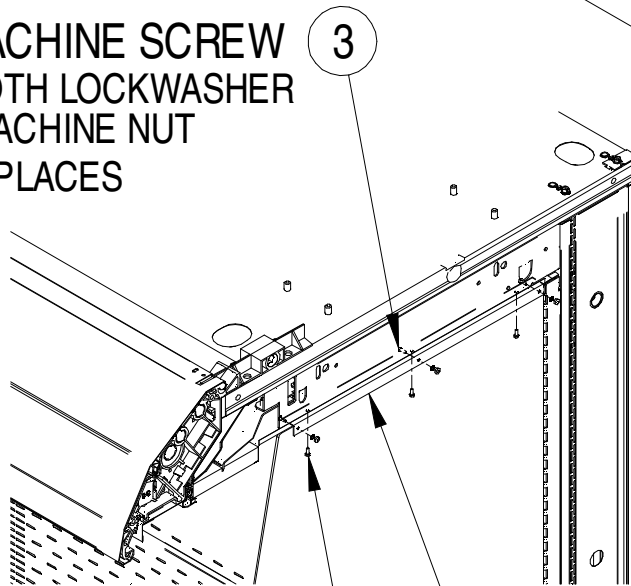

3

1 BRACKET-CANOPY

2

#8 X 5/8 SCREW
3 PLACES

**CONVERTIBLE
ACRYLIC PARTITIONS**
Refer to detail views

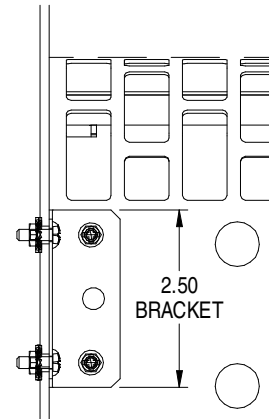

RETURN AIR GRILL VIEW
APPROXIMATE LOCATION
OF BRACKET

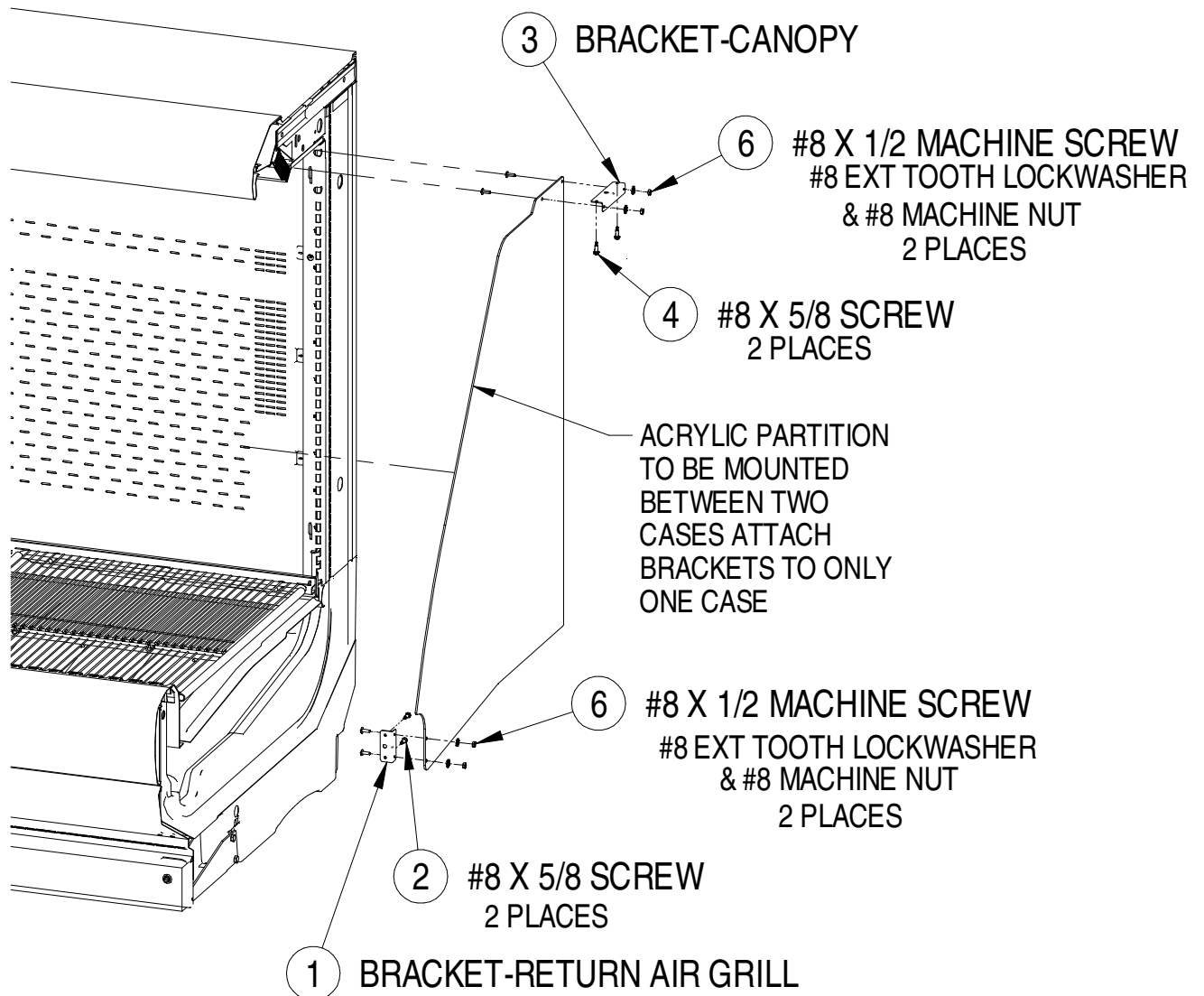

INSTALLING BUMPERS

1. Bumpers are packed out with the case and snap onto the bumper retainer. Gaskets are factory installed in the bumper retainers to provide support for the bumpers. Do not remove the gaskets.
2. Bumper joint inserts are provided with the case to disguise joints for a lineup of cases.
3. Start at the left end of the lineup. Install 3ft starter bumper first. Refer to bumper side view illustration to ensure the bumper is orientated correctly. Place top of bumper over bumper retainer, then snap bottom of bumper into place at bottom of retainer. Position internal joint trim between the starter bumper and full-length bumper.

4. Continue installing bumper(s) until the lineup is complete. The last piece of bumper will need to be cut so that it is flush with the right end cap. Use a fine tooth saw to cut the bumper vertically at a 90° angle.
5. Ensure joint trim is positioned behind bumper at all joints to close any gaps in the lineup. Remove protective film from bumper once installation is complete.

NOTE  Bumpers come in two styles — **Ellipse and Faceted.**

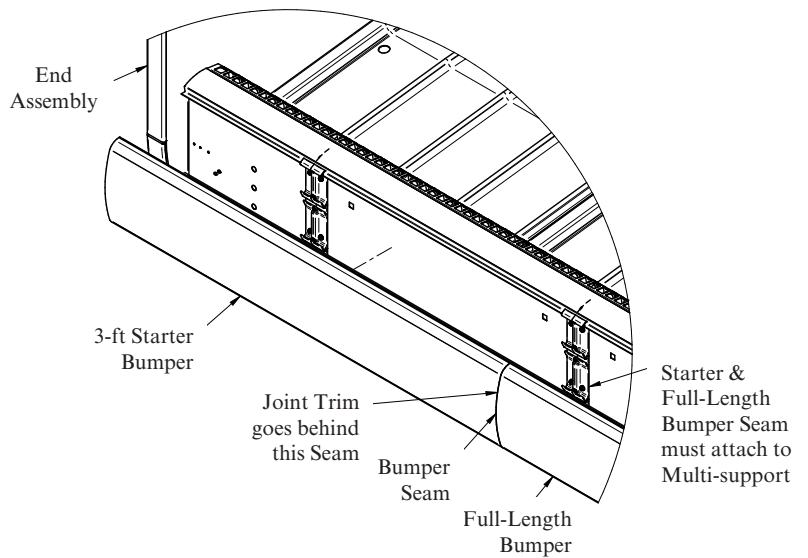
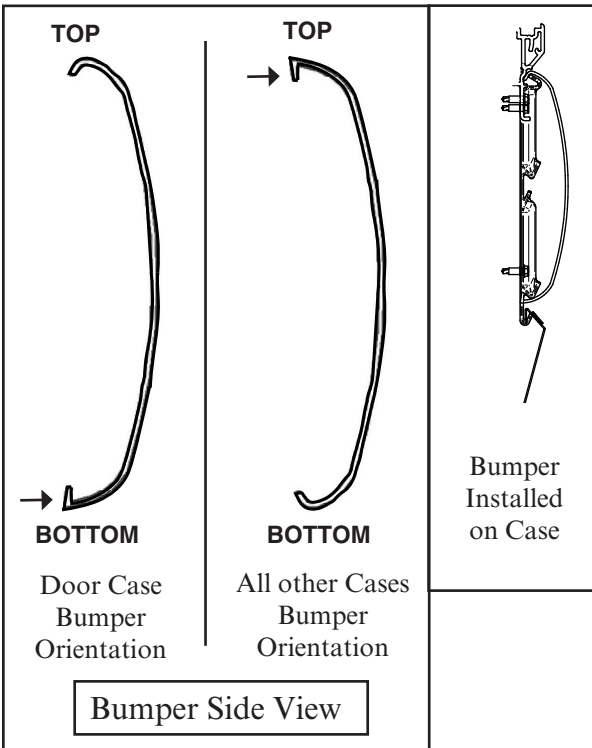
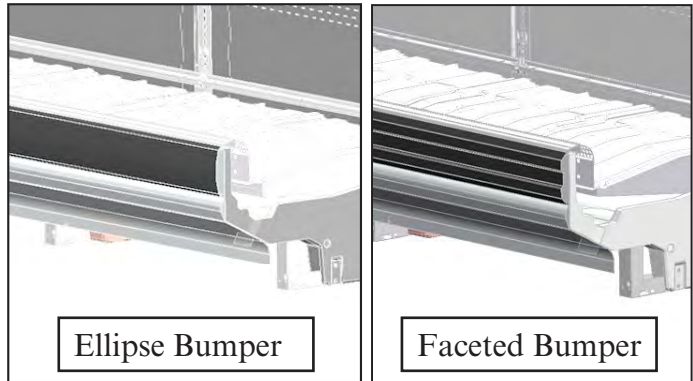

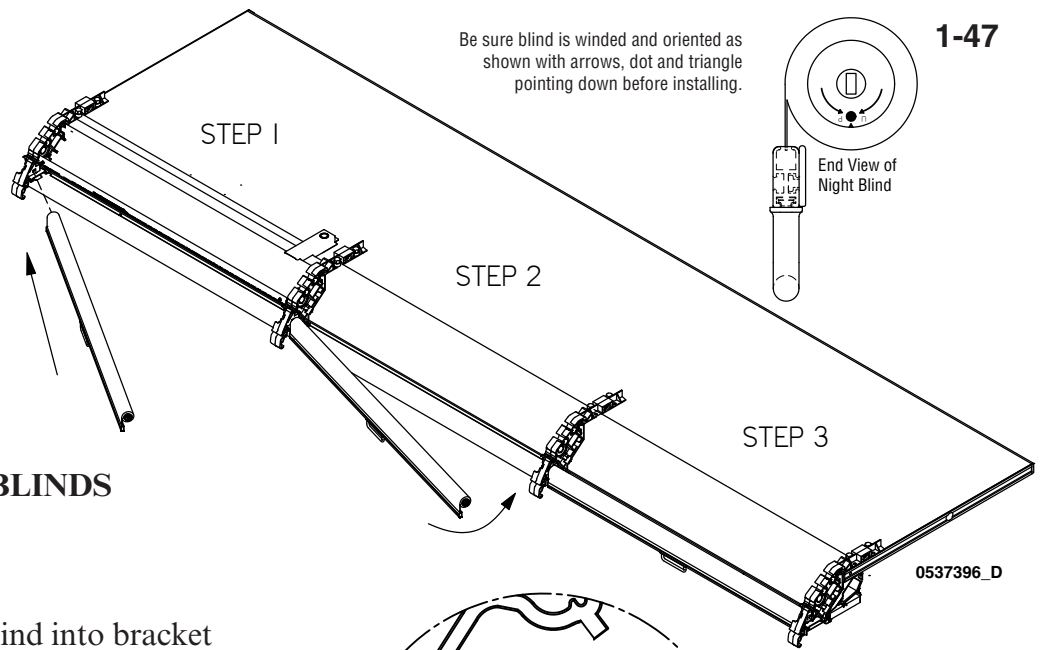

INSTALLING NIGHT BLINDS

STEP 1

Slide the lefthand night blind into bracket cutout.

NOTE Left section of case always uses the front cutout. Alternate front to back for remaining sections.

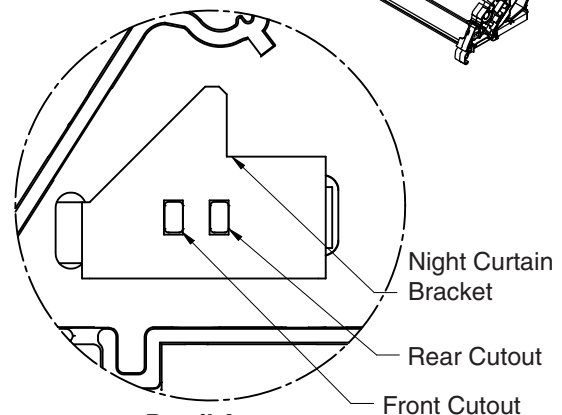

Detail A

Brackets Always on Left Side of Night Curtain

STEP 2

Swing righthand side of night blind into slot on side of canopy support arm.

NOTE Left section of case always uses the bottom slot. Alternate bottom to top for remaining sections.

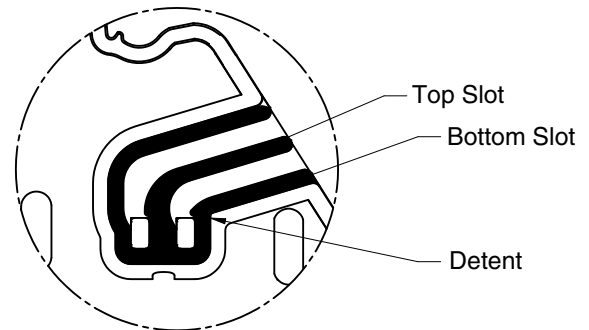

Detail B

Slots always on right side of night blind

STEP 3

Push/pull down on night blind slightly to slide pin past detent.

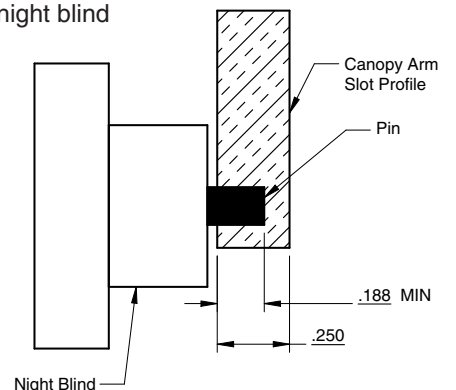

STEP 4

Check pin engagement to ensure at least 3/16" of pin is firmly in the slot.

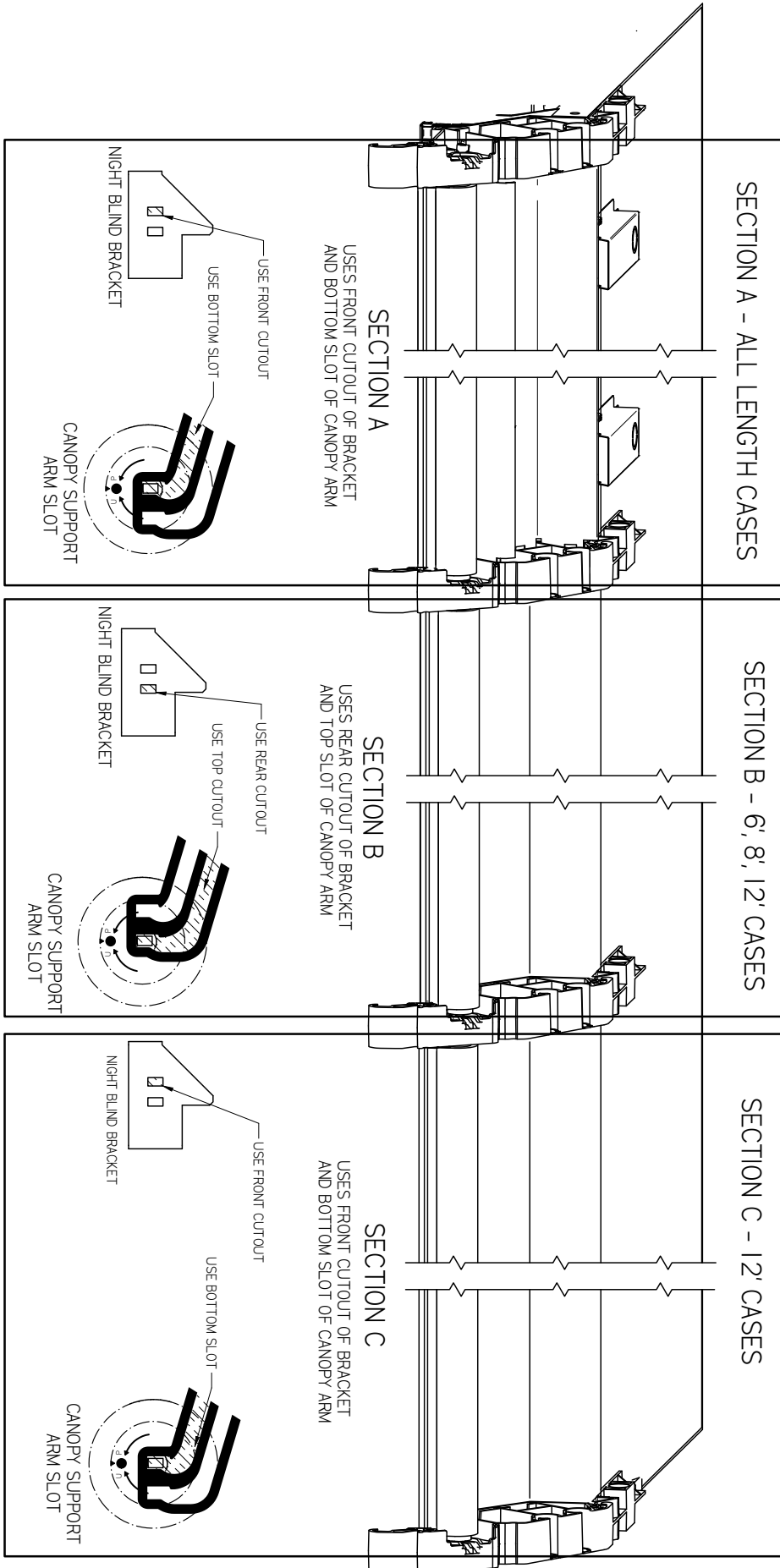

LOADING BLIND SPRING

Night blinds are delivered pre-loaded. However, if it is necessary to load night blind spring, use a wrench (part number 0477098) to twist rectangular pin on right side of night blind. Twist clockwise 14 to 15 full revolutions.

NOTE  **Keep arrow / dot / up pointed up while winding. Keep pointed down when installed.**

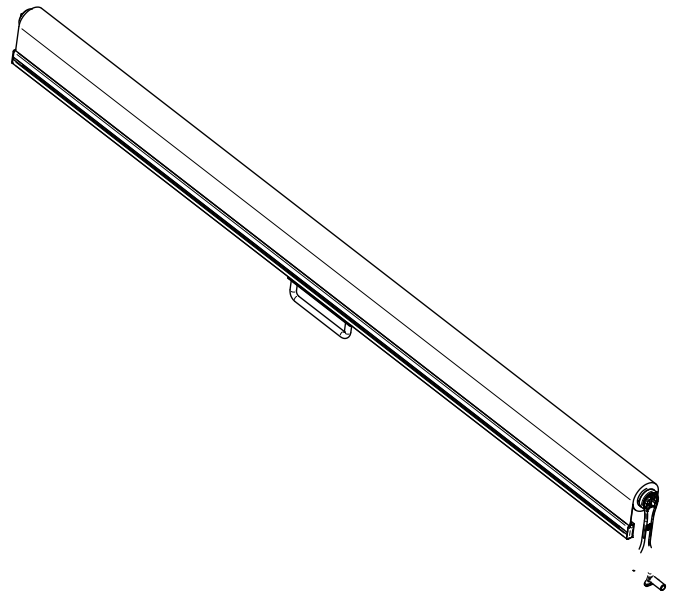

Image showing wrench tightening night blind

Reference Mark (triangle or circle) must be oriented upward when winding and downward during installation.

Night Blind Handle

Rectangular Pin

Night Blind

Wrench
0477098

Twist wrench clockwise for 14 to 15 revolutions



TROUBLESHOOTING NIGHT BLINDS

If night blind is not installed:

STEP 1

Only install brackets on the lefthand support arm and each center support arm.

STEP 2

On the righthand side of each arm, insert front tab of bracket into the front slot, then snap into the rear slot.

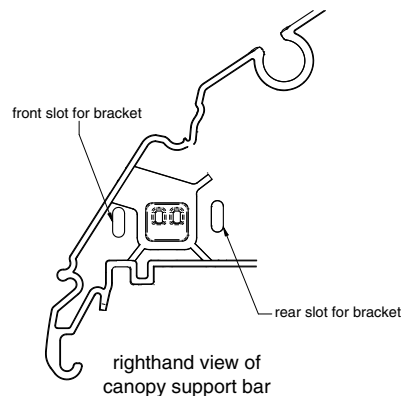
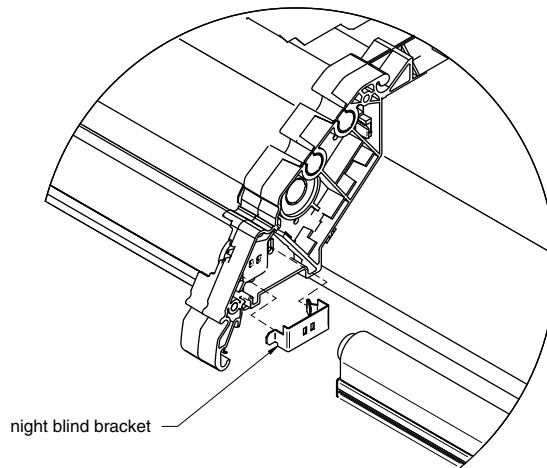

If pin is too short or rounding out canopy arm:

STEP 1

Remove night curtain from case

STEP 2

Use pliers to pull metal pin out to desired length

STEP 3

Replace night curtain into canopy

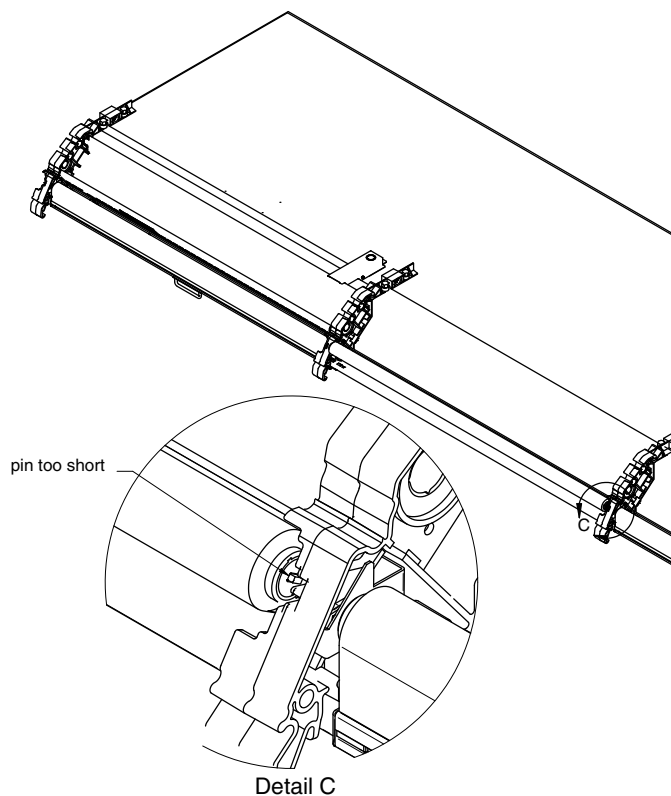

NOTE 

Keep pointed down when installed.

REFRIGERATION / ELECTRICAL

⚠ WARNING

- » Refrigeration lines are under pressure and should be de-pressurized before attempting to make any connections.
- » Refrigerant vapor is hazardous to your health and can cause death.
- » Avoid breathing refrigerant and lubrication vapor or mist. Exposure may irritate eyes, nose and throat. If accidental system discharge occurs, ventilate work area before resuming service.
- » Always wear safety goggles and protective gloves when working with refrigerants. Contact with refrigerant may cause injury. Disconnect hoses with extreme caution! All hoses may contain liquid refrigerant under pressure.
- » Be sure that any room where you are working is thoroughly ventilated, especially if a leak is suspected.
- » Read all safety information regarding the safe handling of refrigerant and refrigerant oil, including the Material Safety Data Sheet. MSDS sheets can be obtained from your refrigerant supplier.

It is recommended to use an expanding polyurethane foam insulation. Cover foam with silicone to prevent water from entering foam.

Refrigerant lines must not interfere with the drain covers. Drain covers must be removed to provide access for cleaning.

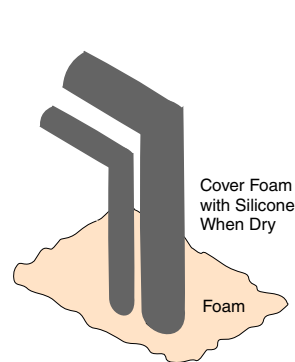

REFRIGERANT

The correct type of refrigerant will be stamped on each merchandiser's serial plate. The merchandiser refrigeration piping is leak tested, factory sealed and pressurized. Before making refrigeration hookups, depress the universal line valve to ensure that coils have maintained pressure during shipment. When using high glide refrigerants (e.g., R-407A, R-448A), if superheat needs to be adjusted, use the evaporator pressure and subtract the dew point from the coil outlet refrigerant temperature to measure the superheat level.

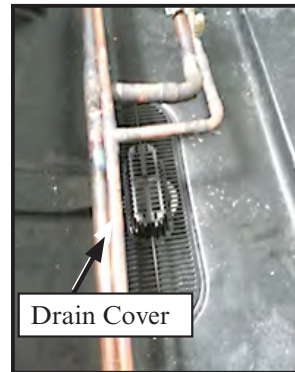

REFRIGERANT PIPING

Standard Case Connection Location

The refrigerant line connections are at the right end of the merchandiser (as viewed from the front) beneath the display pans. The installer must saw a hole to exit the case. After connections have been made, thoroughly seal this outlet. Seal both the inside and the outside.

⚠ WARNING

- » Hussmann does not recommend using spray hoses or misting systems due to risk of serious injury or death from electrical shock.
- » Do not use spray hoses or misting systems on cases with shelf or rail lighting.

Back Wall Piping Penetrations

Cases that are to be piped from the back have a factory installed ¼ pilot hole in the exterior liner. Use the pilot hole to locate the hole saw to drill out a hole 2½ in. diameter hole to run the coil piping.

After connections have been made, thoroughly seal this outlet. Seal both the inside and the outside.

It is recommended to use an expanding polyurethane foam insulation. Cover foam with silicone to prevent water from entering foam.

⚠ CAUTION

» When brazing pipes be sure to use the insulation blanket shipped with the merchandiser to prevent damage to the foam bottom.

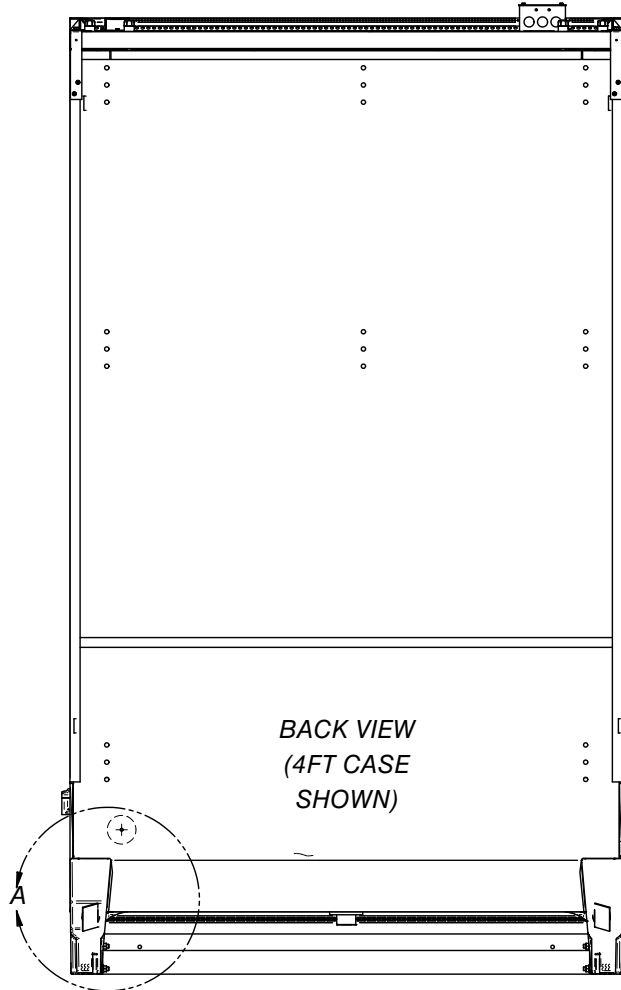
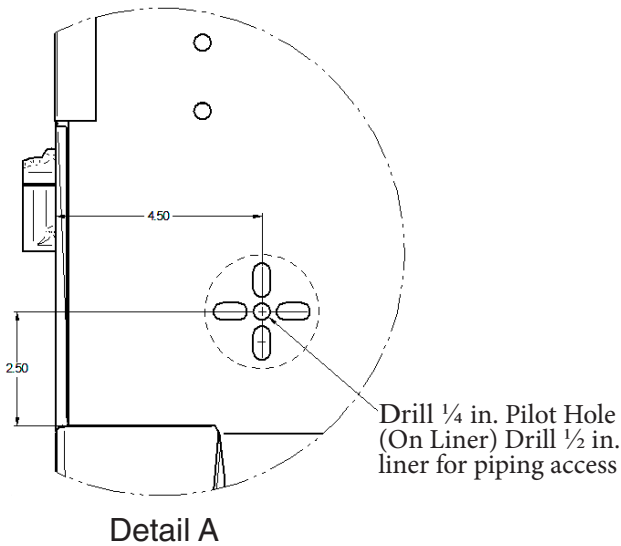

Narrow and Wedge Case Connection use Shroud

A shroud should be used to seal pipe penetrations in the bottom liner for narrow In-sight cases as well as wedge cases. Saw a hole through the bottom liner that is large enough to fit the refrigerant piping.

Place the refrigeration shroud over refrigeration piping so that when the shroud is rotated into place, it will be in the upright position.

Use the supplied refrigeration brazing blanket to avoid burning the liner. Be careful not to burn, scorch or over-heat the shroud when making connections

Attach the shroud to the liner using 8 supplied screws. Apply a continuous bead of silicone sealant around the bottom of the shroud after all connections are made and insulation has been applied to the piping. Seal the outlet thoroughly. Seal both the inside and outside. Hussmann recommends using expanding polyurethane foam insulation. Cover foam with silicone to ensure seal around insulation and to prevent deterioration of foam.

NOTE: Wedge cases get sheet metal screws, narrow cases use plastic screws.

Multiplexing

Piping of merchandisers operating on the same refrigeration system may be run from merchandiser to case. Do not run refrigerant lines through merchandisers that are not on the same refrigeration system branch as this may result in poor refrigeration control and compressor failure.

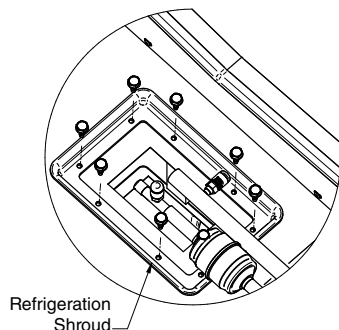

Interconnecting piping inside the case must be located as shown below to allow room for lifting the hinged fan plenums and for clearance beneath the display pans. Alternately, the interconnecting piping may be run outside the case.

Line Sizing

Refrigerant lines should be sized as shown on the refrigeration legend that is furnished for the store or according to ASHRAE guidelines. Refer to the information on the next page for branch line piping of Hussmann Equipment.

Oil Traps

P-traps (oil traps) must be installed at the base of all suction line vertical risers.

Pressure Drop

Pressure drop can rob the system of capacity. To keep the pressure drop to a minimum, keep the refrigerant line run as short as possible using a minimum number of elbows. Where elbows are required, use long radius elbows only.

INSULATION

Additional insulation for the balance of the liquid and suction lines is recommended whenever condensation is objectionable or lines are exposed to ambient conditions.

SUCTION LINE

- Pitch in direction of flow.
- May be reduced by one size at one third of merchandiser run load and again after the second third. Do not reduce below the merchandiser suction line size.
- Merchandiser suction lines should enter at the top of the branch line.

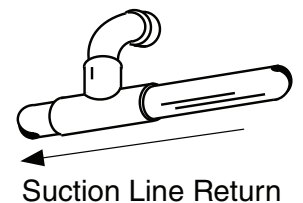

LIQUID LINE

- May be reduced by one size after one half the merchandiser run load. Do not reduce below the merchandiser liquid line connection size.
- Take-offs to merchandiser liquid lines should exit the bottom of the branch liquid line. Provide an expansion loop for each evaporator take-off (minimum 3 in. [76 mm] loop).

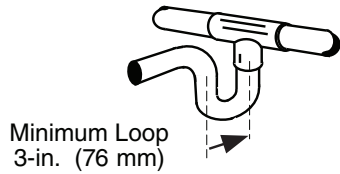

Liquid Line Take Off

REFRIGERATION THERMOSTAT

Insight models do not use a defrost termination thermostat and are time terminated only.

DEFROST SEQUENCES

Insight merchandisers require defrost cycles for proper operation. Refer to the data sheets for application data. The Time Clock initiates defrost. The evaporator fans continue to circulate air across the evaporator coil, melting any frost build-up.

If temperature termination is required, an applicable defrost sensor must be installed on the case.

MERCHANDISER ELECTRICAL DATA

Technical data sheets are also shipped with the case. The data sheets provide merchandiser electrical data, electrical schematics, parts lists and performance data. Refer to the technical data sheets and merchandiser serial plate for electrical information.

ELECTRICAL CONNECTIONS

All wiring must be in compliance with NEC and local codes. All electrical connections are to be made in the electrical wireway or *Handy Box*.

FIELD WIRING

Field wiring must be sized for component amperes stamped on the serial plate. Actual ampere draw may be less than specified.

Offtime Defrost

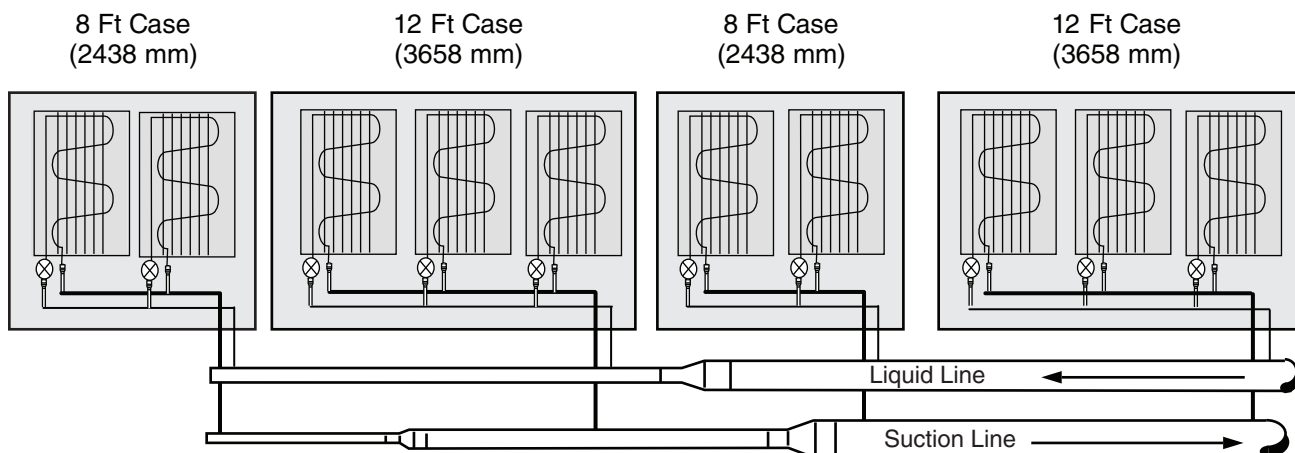

Field wiring from the refrigeration control panel to the merchandisers is required for defrost termination thermostats and for optional refrigeration thermostats. When multiple merchandisers are on the same defrost circuit, the defrost termination thermostats are wired in series.

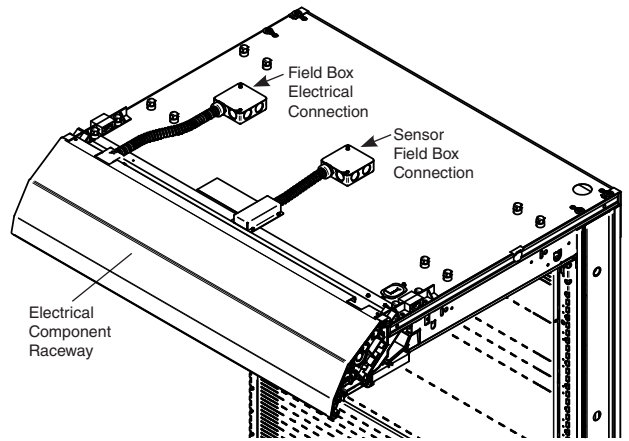

IDENTIFICATION OF WIRING

ALWAYS CHECK THE SERIAL PLATE FOR COMPONENT AMPERES.

Leads for all electrical circuits are identified by colored plastic bands. These bands correspond to the *color code sticker* (shown below) located inside the merchandiser's wireway cover.

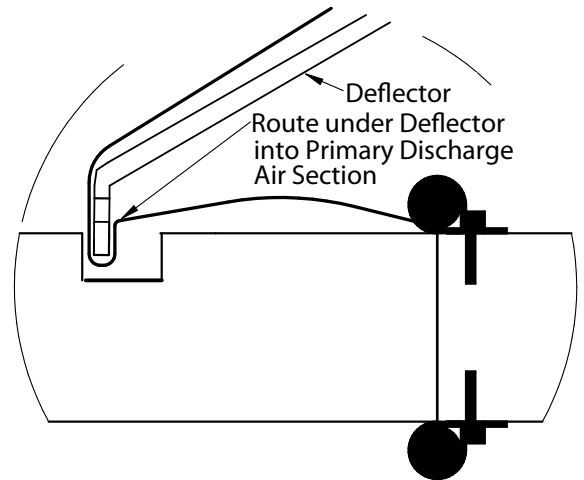

SENSOR LOCATION

Discharge air sensor is located in the case canopy by the honeycomb. An electrical box is shown at right for field installation of the sensor. (Field box may not be present if a sensor was not originally factory installed.)

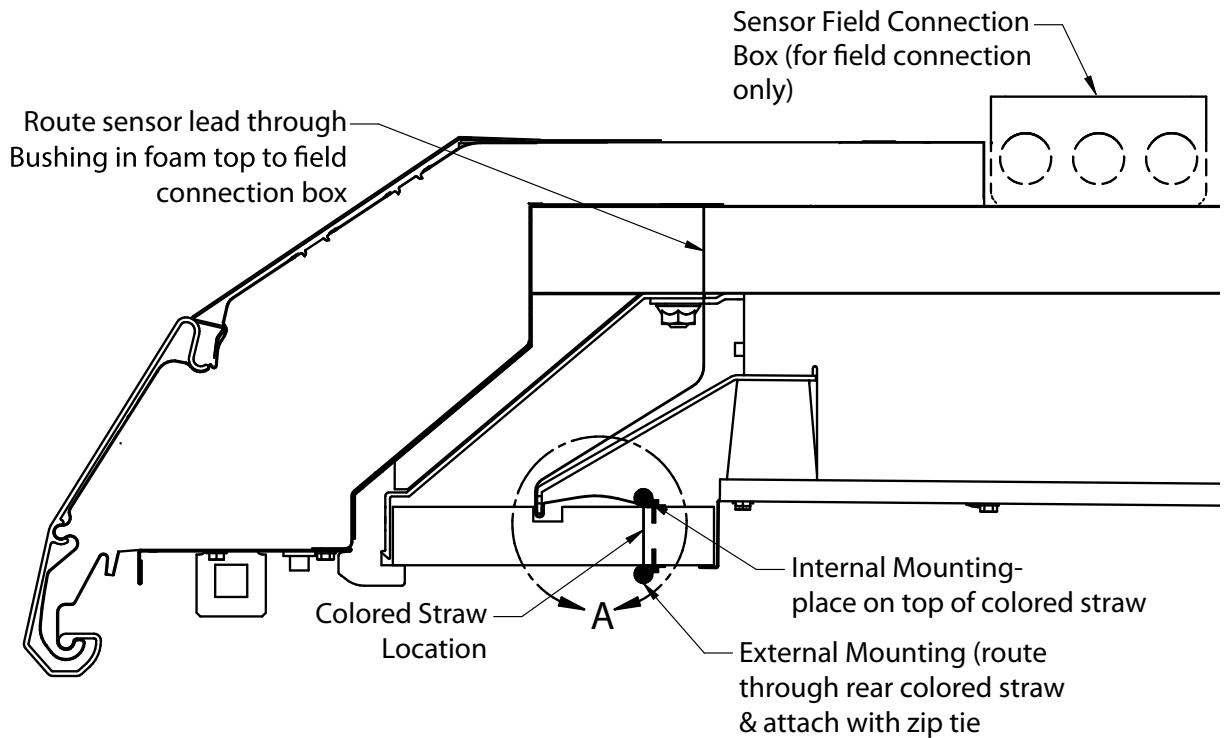

**ELECTRICAL ACCESS FOR
SIGN-READY & FLAT-FRONT
FASCIAS**

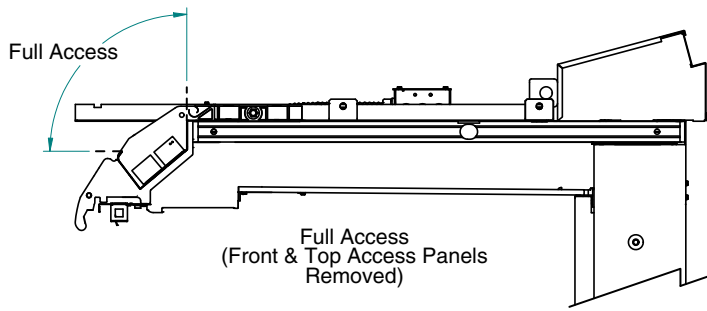
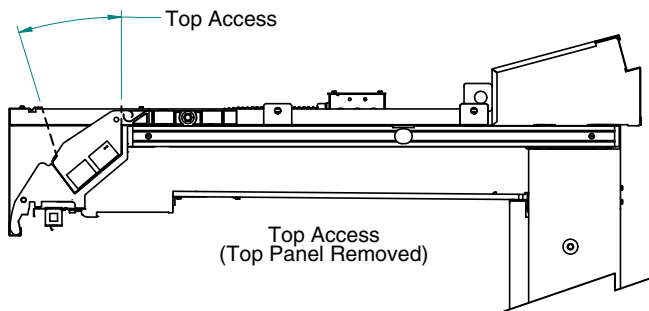
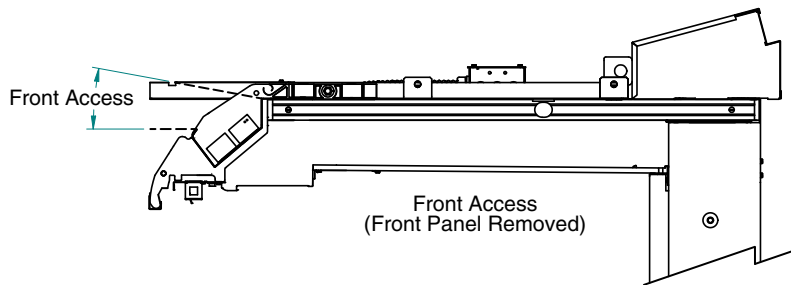
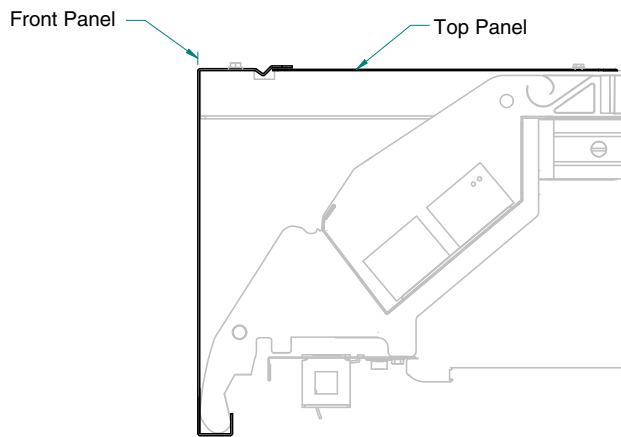

WIRING COLOR CODE

Leads for all electrical circuits are identified by a colored plastic band: neutral wire for each circuit has either White insulation or a White plastic sleeve in addition to the color band.

PINK.....	REFRIG. THERMOSTAT LOW TEMP.	ORANGE OR	
LIGHT BLUE ...	REFRIG. THERMOSTAT NORM TEMP.	TAN	LIGHTS
DARK BLUE....	DEFROST TERM. THERMOSTAT	MAROON.....	RECEPTACLES
PURPLE.....	CONDENSATE HEATERS	YELLOW	DEFROST HEATERS 120V
BROWN	FAN MOTORS	RED	DEFROST HEATERS 208V
GREEN*	GROUND *EITHER COLORED SLEEVE OR COLORED INSULATION		

**ELECTRICIAN NOTE: Use copper conductor wire only.
MERCHANDISER MUST BE GROUNDED**

THESE ARE MARKER COLORS, WIRES MAY VARY.

HANDLING ELECTROSTATIC SENSITIVE DEVICES (FAN SELECTOR)

Some Insight merchandisers are equipped with a fan speed selector to optimize fan speeds and enhance energy performance. The electronics may be standard or later installed to the cases as a kit. These electronics consist of an input in the motor, and a controller with a key that allows fan speeds to be changed. (Only a professional technician should make any changes to the fan speeds.) A different speed key may need to be ordered to change the fan speed. Contact your Hussmann representative to learn and order what speed key is appropriate for your products.

ESD (electrostatic discharge) sensitive device. Charged devices and circuit boards can discharge without detection. Although this product contains protection circuitry, damage may occur on devices subjected to high energy ESD. Proper precautions should be taken to avoid loss of functionality.

A field grounding kit is recommended for installation of components from a kit or for field service work performed by internal service personnel. The following equipment is recommended for work being performed in the case:



Example of Grounding Kit
3M 8507 with audible alarm

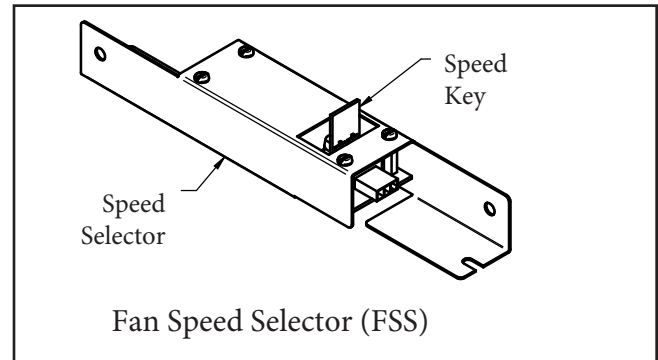

DO:

- Minimize handling.
- Keep parts in original packaging until ready for use.
- Store and carry components in Original Manufacture Packaging or equivalent Static shielding bags.
- Discharge static before handling device by touching nearby grounded surface.
- Handle devices by the body.
- Keep a dust free work area.

DON'T:

- Touch the leads of any device.
- Slide ES Sensitive devices over any surface.
- Store or carry components or assemblies in plastic bags.
- Store sensitive components in thermocole/ plastic foam.

Field Ground Kit with instructions for use
Recommended Suppliers/Distributors of
Equipment:

DESCO Industries

Part Numbers (18575 or 18576 or 95651)

3M Corporation

Part Numbers (8501 or 8505 or 8507 or
FSKL3RD)

Amazon, DigiKey, Grainger, Mouser, Newark.
Search under ESD Service Kits.

INSTALLING TYPE II FAN SPEED SELECTOR KIT

A fan speed selector may be required for a merchandiser to operate for certain applications such as Type II conditions. However, if the speed key is removed, the fans will return to the default fan speed, which typically aligns with Type I operation. Each key is configured from the factory to operate for the specific model for which it was ordered.

ANSI/NSF-7 Type II – Display Refrigerator / Freezer Intended for 80°F / 55% RH Ambient Application

Contact your Hussmann representative to order this kit if the cases in your lineup are required to operate in Type II conditions. The selector will operate up to 6 fan motors. Only an experienced electrician should install the fan selector.

1. Mount the selector inside of the wireway of each case. Insert the speed key into the selector. Insert harness connector (2-pin) into the Selector. The 2-pin side supplies power to the selector. It can be used with 110V or 220V circuits.

2. Insert the harness connector (3-pin) into the selector. The 3-pin side sends a signal to the fan motor and the fan speed RPM is now changed to the new setting.

Harness Routing and Field Connections are shown on the next Page.

⚠ WARNING

— LOCK OUT / TAG OUT —

- » To avoid serious injury or death from electrical shock, always disconnect the electrical power at the main disconnect when servicing or replacing any electrical component. This includes, but is not limited to, such items as doors, lights, fans, heaters, and thermostats.

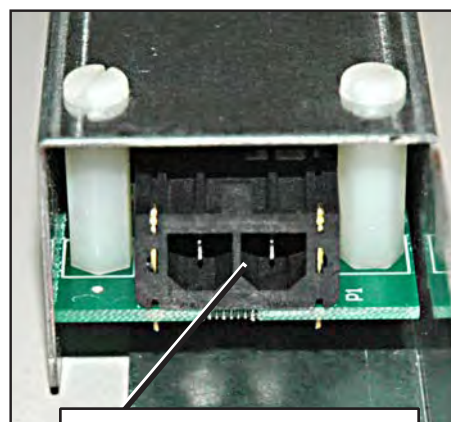

2-Pin Input Line Voltage to Selector

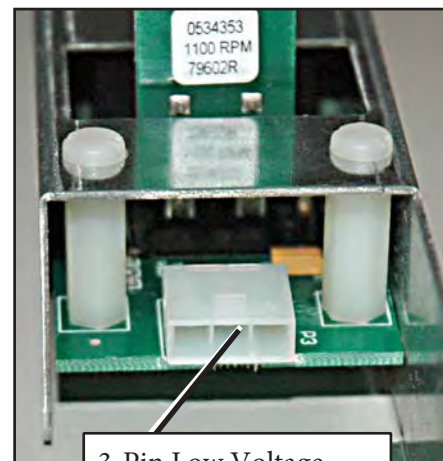

3-Pin Low Voltage Signal to Fan Motor (for RPM Speed)

TYPE II FAN SPEED SELECTOR LOCATION

**Fan Speed Selector Harness Routing
Tall Multi-Deck (when required)**

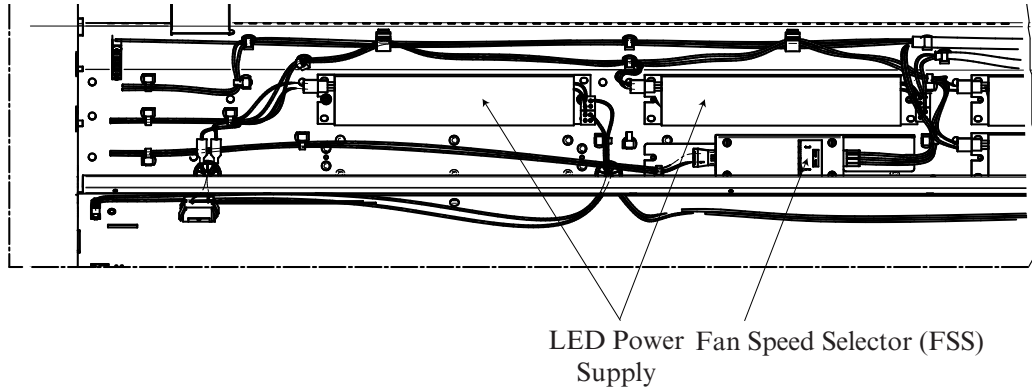

**Fan Speed Selector Harness Routing
Single Deck IC2, IC2X IC3 (when required)**

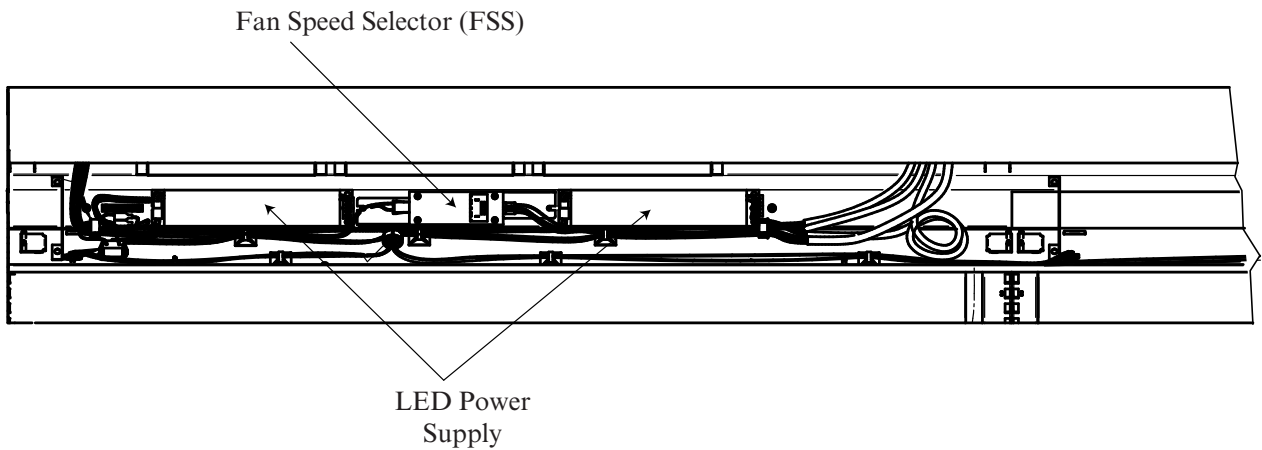

**Fan Speed Selector Harness Routing
Single Deck IM1-IP1-IC1 (when required)**

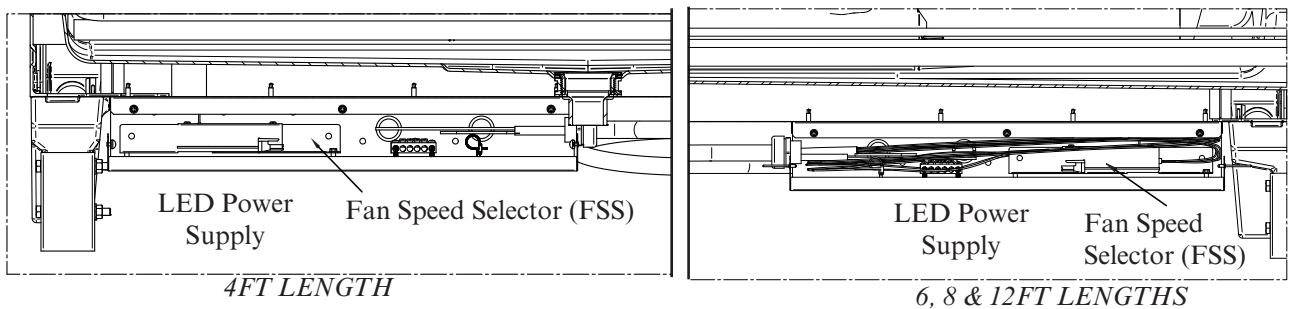

NOTES:

DRIP PIPING / FIT & FINISH / SPLASHGUARDS

WASTE OUTLET AND WATER SEAL

Insight merchandisers have one waste outlet located in the front center of the bottom or righthand side for 8 ft cases. Water seals are field installed with waste outlet to prevent air leakage and insect entrance into the case. Tees and clean-outs are supplied for each case.

A hat-shaped strainer is also shipped with the merchandiser. Place strainer over the waste outlet as shown below.

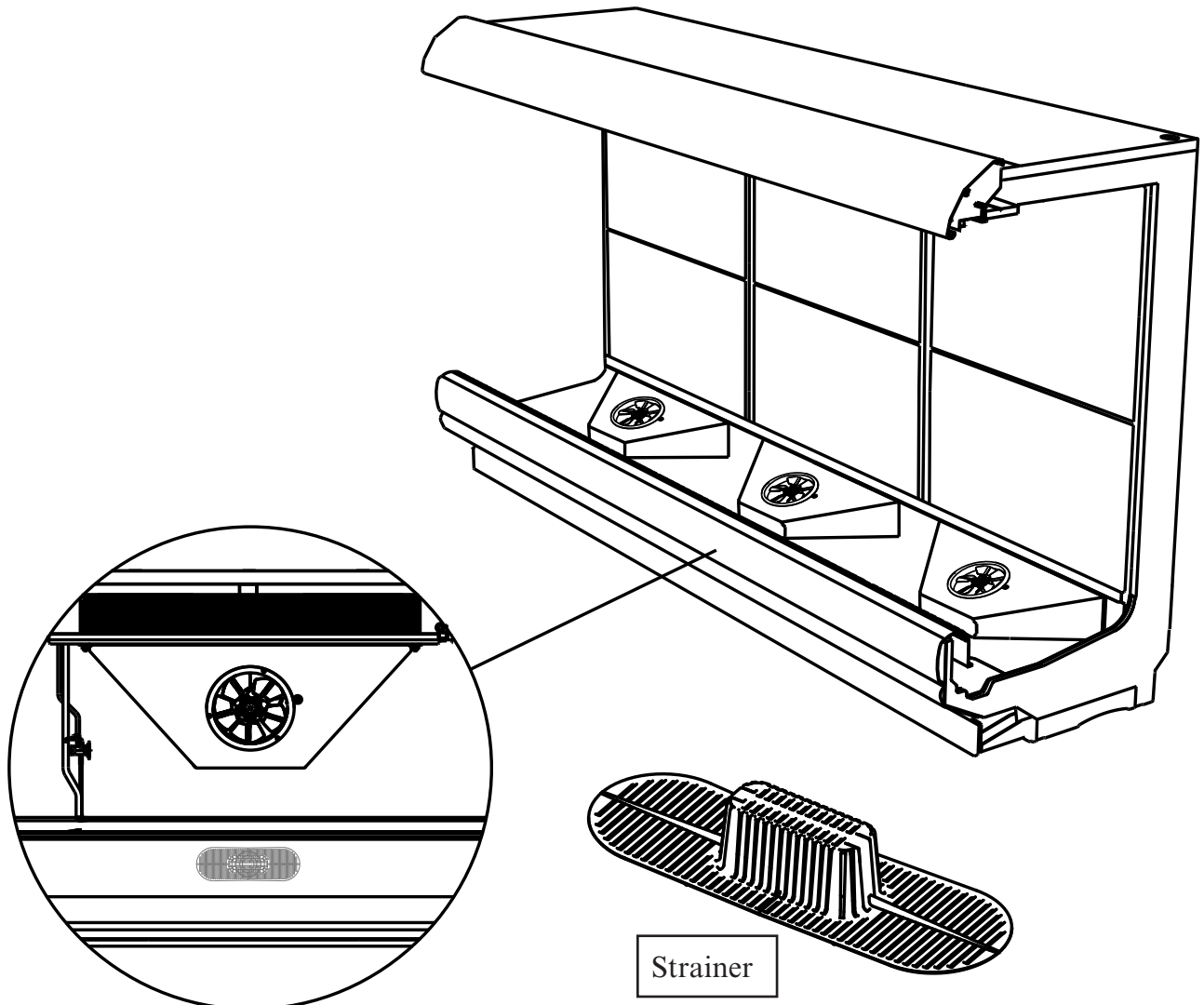
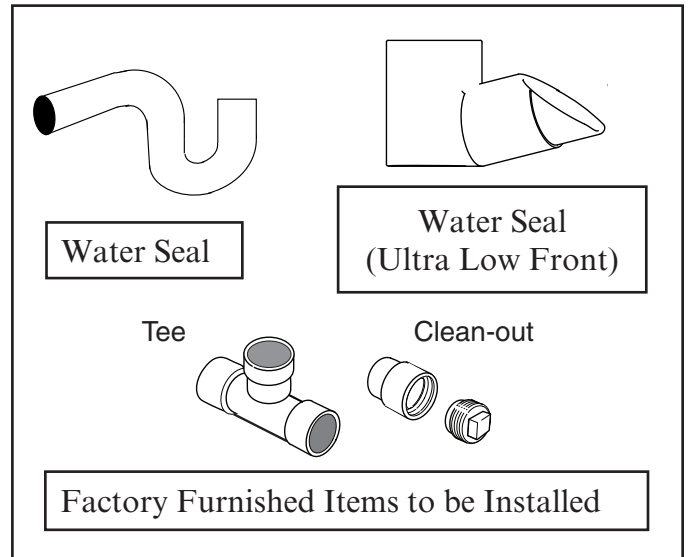

INSTALLING DRIP PIPING

Poorly or improperly installed drip pipes can seriously interfere with the merchandiser's operation and result in costly maintenance and product losses.

Optional drip pipe arrangements are shown on the next page. It is the installing contractor's responsibility to consult local agencies for local code requirements. Assemble the components using field-supplied PVC primer and glue according to the manufacturers direction.

Please follow the recommendations listed below when installing drip pipes to ensure proper installation.

1. When connecting drip piping, the "water seal" must be used as part of the drip piping to prevent air leakage or insect entrance. Never use two water seals in series in any one drip pipe. Double water seals in series will cause an air lock and prevent draining.

2. Pitch the drip piping in the direction of flow. **There should be a minimum pitch of ¼ in. per ft (20 mm per 1 m).**

3. Avoid long runs of drip piping. Long runs make it impossible to provide the pitch necessary for good drainage.

4. All connections must be watertight and sealed with the appropriate PVC or ABS cement.



Never use drip piping smaller than the nominal diameter of the pipe or water seal supplied with the merchandiser.



It is the installing contractor's responsibility to consult local agencies for local code requirements.

Drip Piping Example for Standard Case Height (Not for Ultra Low Front Cases)

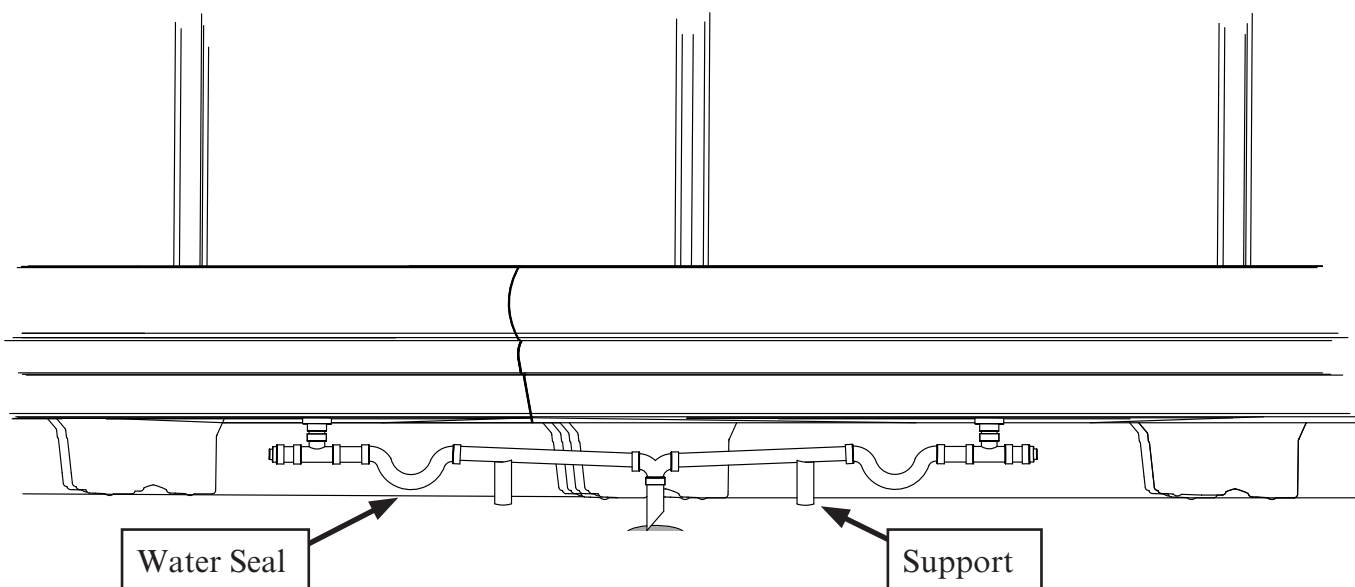

5. Ensure that drip piping is supported to relieve any stress on drip pipe connectors and waste outlet hub. Drip piping **MUST** be supported no more than 24 in. from waste outlet tee.

6. Provide a suitable air break between flood rim of the floor waste outlet and outlet of drip pipe. To meet code on low base merchandisers, it may be necessary to install a field-supplied drip pipe reducer.



An alternative is to cut the last section of drip pipe at an angle.

7. Prevent drip pipes from freezing:

Do not install drip pipes in contact with uninsulated suction lines. Suction lines should be insulated with a nonabsorbent insulation material.

Where drip pipes are located in dead air spaces, such as between merchandisers or between a merchandiser and a store wall, provide means to prevent freezing.

Flush Floor Drip Piping Example for Ultra Low Front Cases



Elbow is to be oriented toward rear of case. Install elbow to tee, place elbow on hub. Push elbow until it meets the liner.

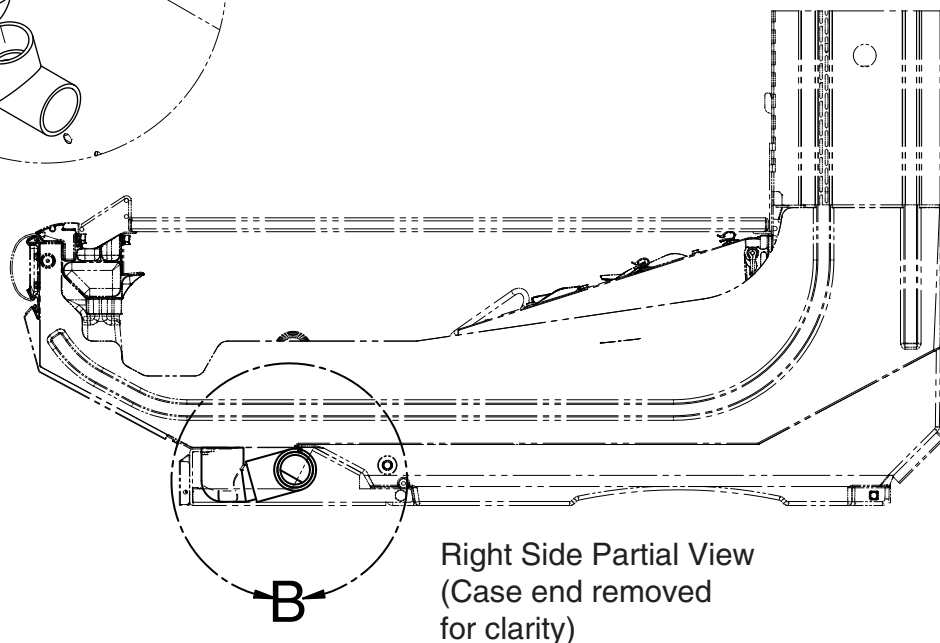
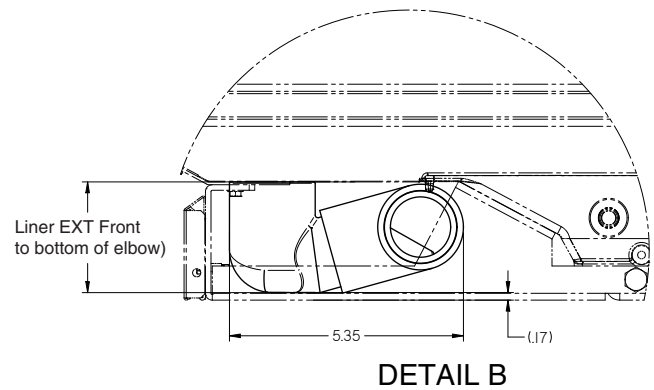
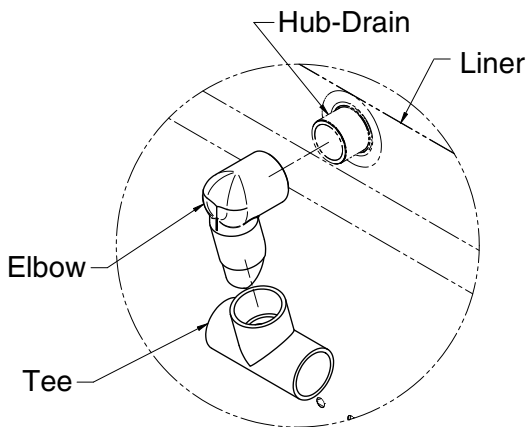

Optional Waste Outlet Drip Piping Example for Ultra Low Front Cases

There is limited space underneath the case for piping ultra low front cases. If there is a waste outlet in the floor, use the ultra low front piping kit. This extends the splashguard forward. Follow the waste outlet location drawings on the following pages to install the drip piping in the correct location. This kit can also be used to pipe multiple cases to a single floor waste outlet/sink.

Item Number	Title	Quantity	Comments
1	ELBOW- AIR SEAL INSIGHT	1	FACTORY INSTALLED
2	TEE-1.25	1	FACTORY INSTALLED
3	BUSHING-PVC REDUCER 1.250 X .50 SLIP	1	FIELD INSTALLED
4	REDUCER BUSHING-1.25x1.00	1	FIELD INSTALLED
5	PLUG-1.00	1	FIELD INSTALLED
6	PIPE-PVC .500 X 3.5 LONG	4	FIELD INSTALLED
7	ELBOW-PVC 90 DEG .500 SLIP	3	FIELD INSTALLED
8	ELBOW-PVC 22.5 DEG .500 SLIP	1	FIELD INSTALLED

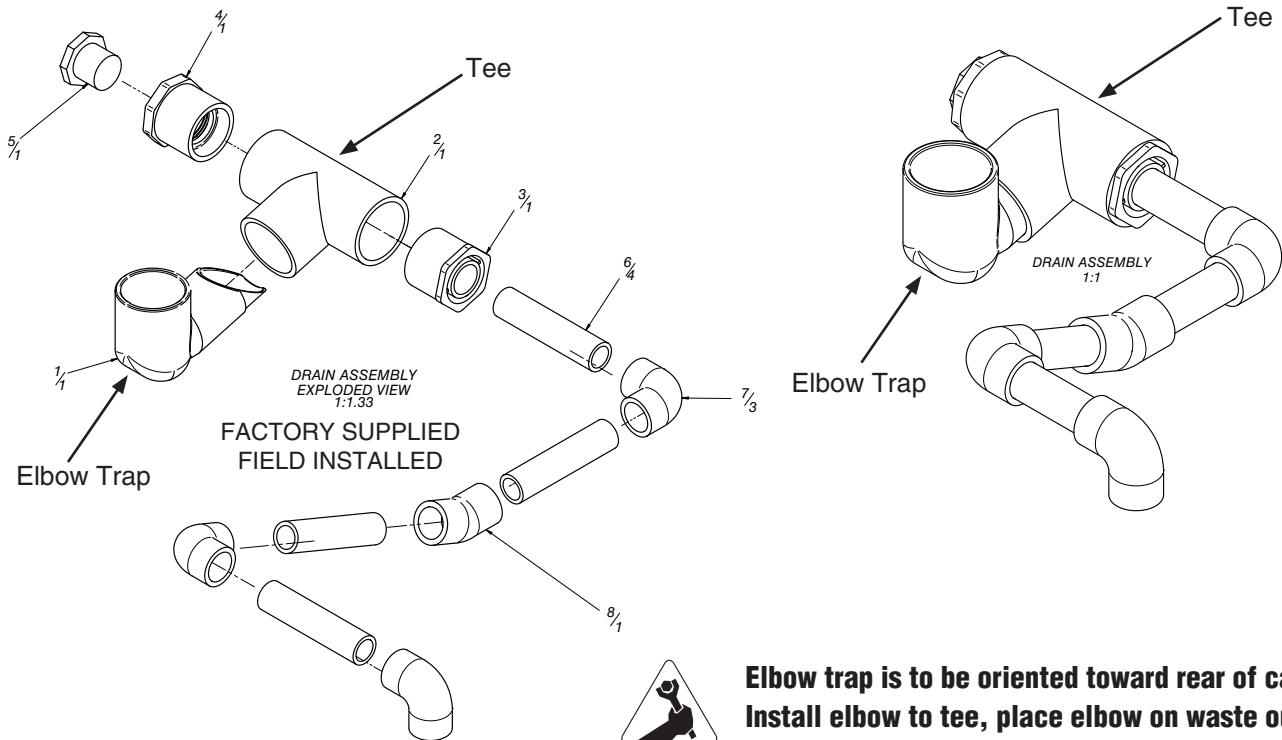

Elbow trap is to be oriented toward rear of case. Install elbow to tee, place elbow on waste outlet of case. Push elbow trap until it meets the liner.

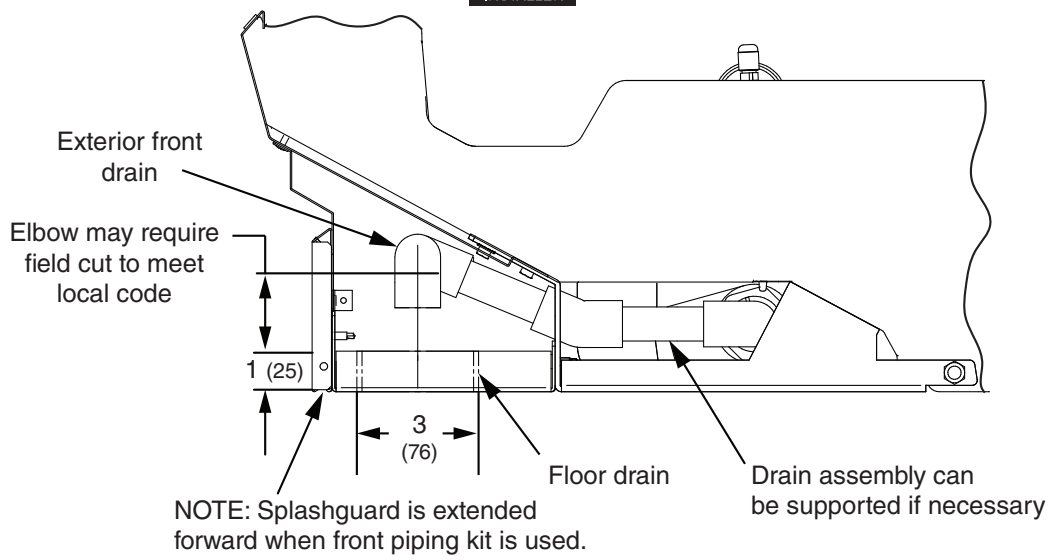

Drain Location with Drain Extension Kit (Dimensions in Inches)

Standard Depth Models Ending in SU	4-foot	6-foot	8-foot	12-foot
(A) RH end of case to center of original waste outlet	24 1/8	24 1/8	24 1/8	72 1/4
(B) RH end of case to center of relocated waste outlet (with drain extension kit) *	13 3/4	13 3/4	13 3/4	61 7/8
(C) Back of case to center of original waste outlet	33 1/2	33 1/2	33 1/2	33 1/2
(D) Back of case to center of relocated waste outlet (with drain extension kit)	38 1/4	38 1/4	38 1/4	38 1/4
(E) Back of case to the back of the relocated splashguard (with drain extension)	41	41	41	41

* Drain Extension shown piped to the right but may be piped either direction

Drain Location with Drain Extension Kit (Dimensions in Inches)

Narrow Depth Models Ending in NU	4-foot	6-foot	8-foot	12-foot
(A) RH end of case to center of original waste outlet	24 1/8	24 1/8	24 1/8	72 1/4
(B) RH end of case to center of relocated waste outlet (with drain extension kit) *	13 3/4	13 3/4	13 3/4	61 7/8
(C) Back of case to center of original waste outlet	28 5/8	28 5/8	28 5/8	28 5/8
(D) Back of case to center of relocated waste outlet (with drain extension kit)	33 1/2	33 1/2	33 1/2	33 1/2
(E) Back of case to the back of the relocated splashguard (with drain extension)	35 1/8	35 1/8	35 1/8	35 1/8

* Drain Extension shown piped to the right but may be piped either direction

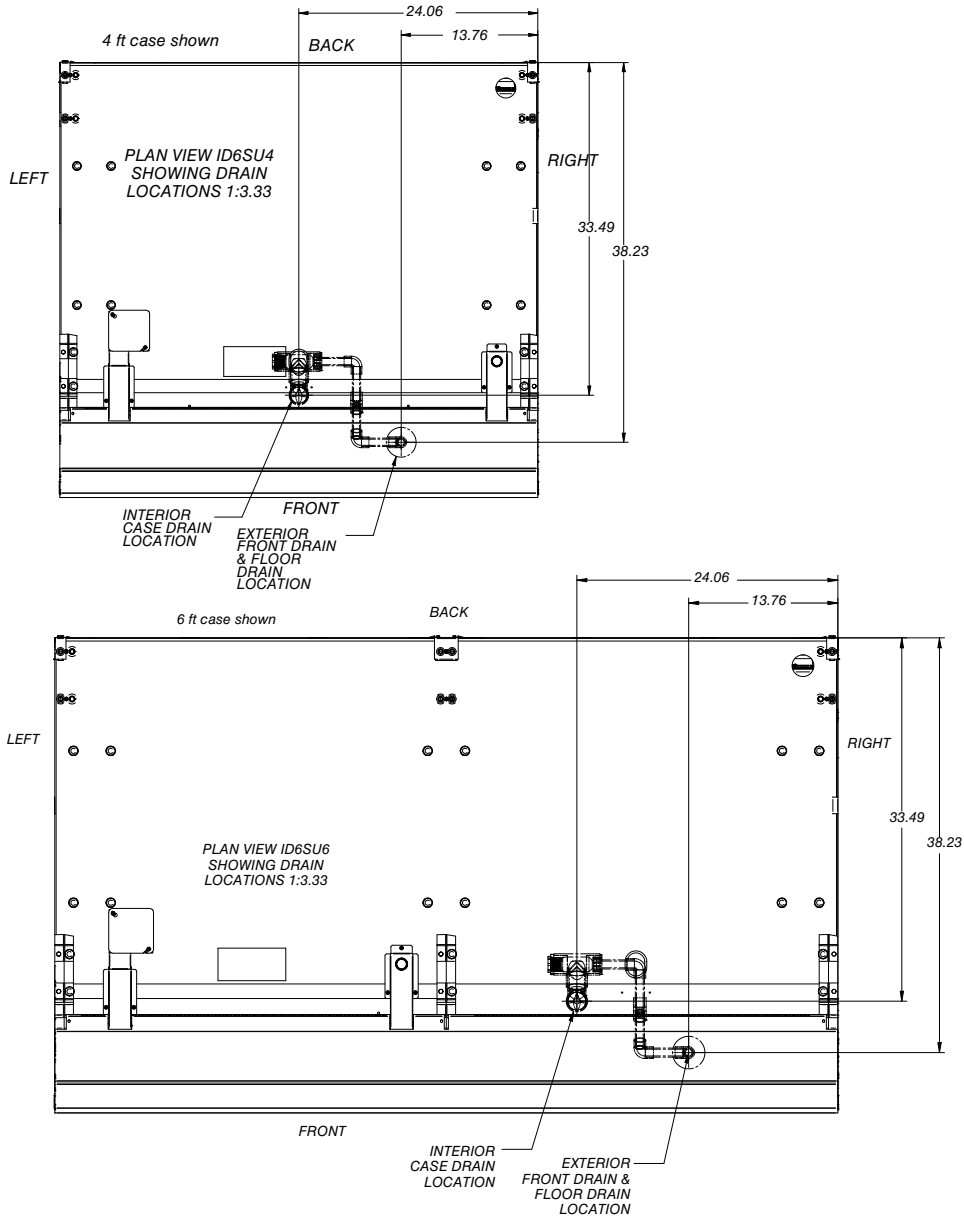

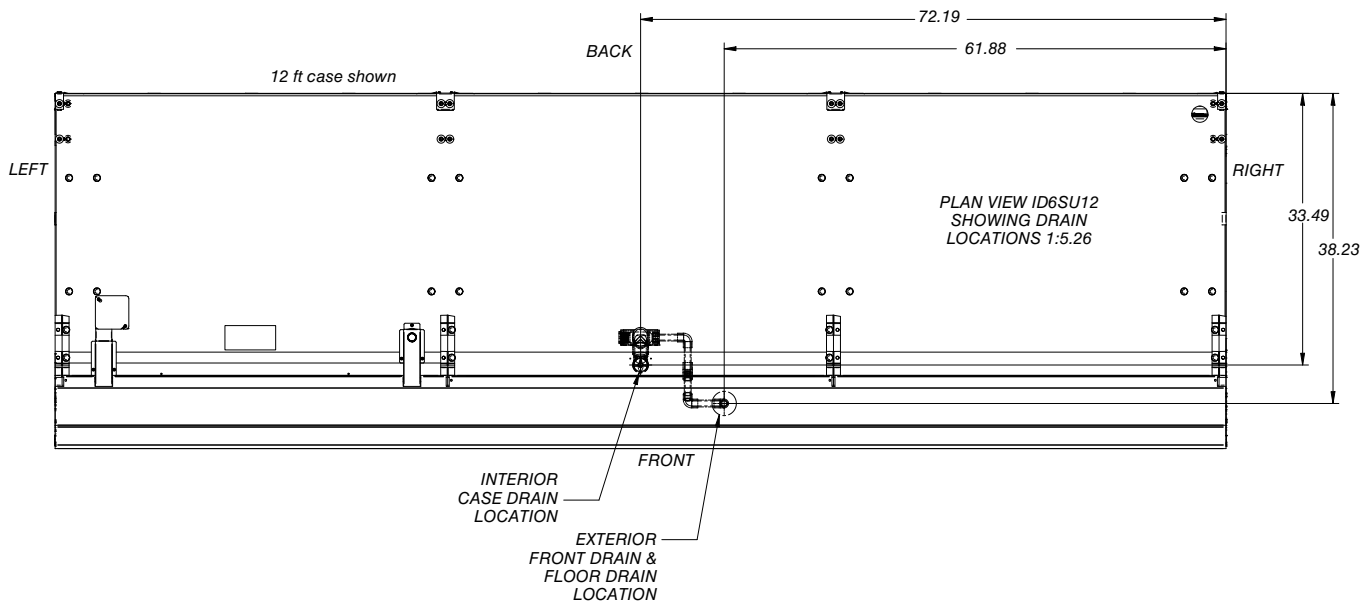
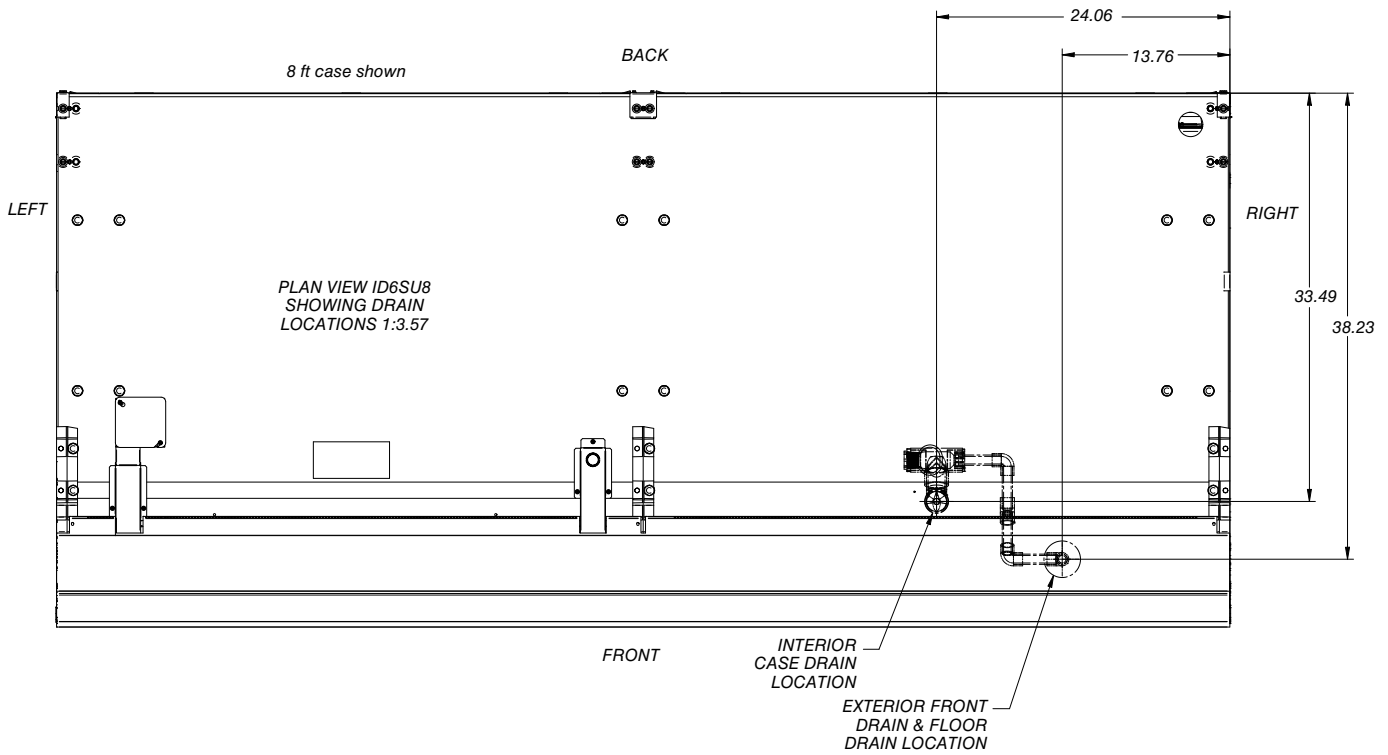

FINAL ALIGNMENT / FIT & FINISH

Fascia Top Cap Alignment

Applies to (IP4/IM5/ID5/ID6/IC6)

Fascia Top Cap can slide toward the center of (multideck) case lineups to eliminate gaps.

1. Pull fascia top cap to uncover fixing screws.

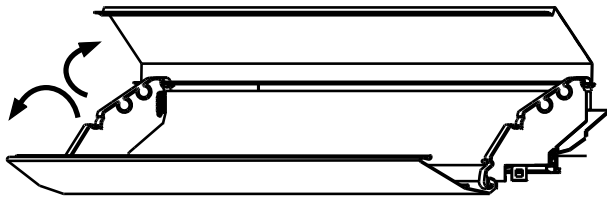

2. Loosen the screws of fascia top cap.

3. Move fascia top cap towards the lineup center. Tighten the screws after finishing the alignment.

4. Snap fascia top cap to closed position.

5. Install fascia trim (optional) between joints and at ends. Hook at bottom first, then snap top into place.

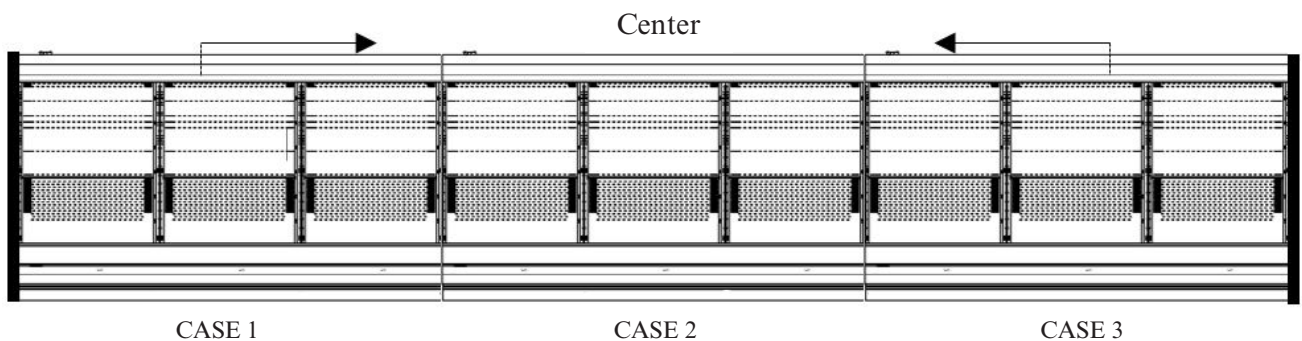
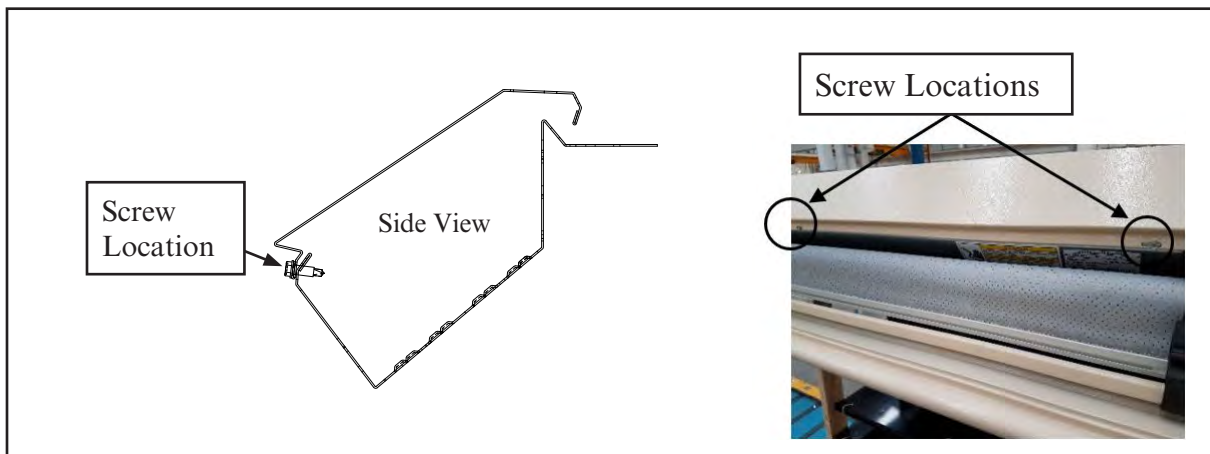
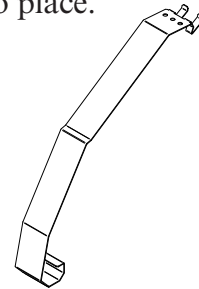

Fascia Panel Alignment

Applies to (IP4/IM5/ID5/ID6/IC6)

Fascia panels can slide toward the center of (multideck) case lineups to eliminate gaps.

1. Slide fascia panels toward lineup center as shown in the illustration below.

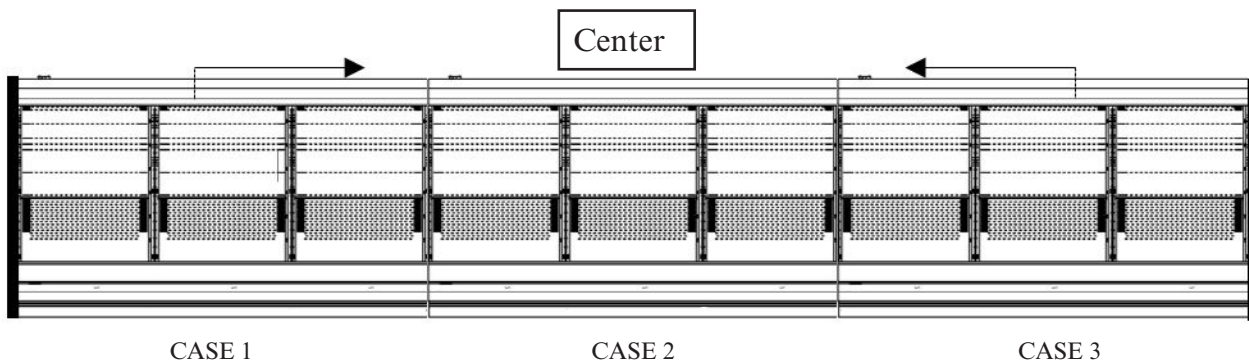
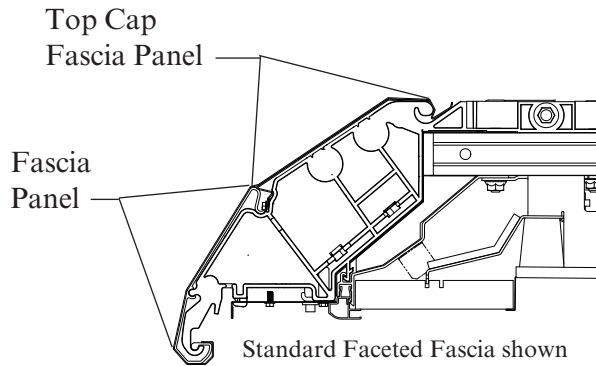

2. Place optional fascia trim between fascia joints between end panel and fascia and between case lineup joints. Install tape to joint first, then attach bottom and top fascia trim.

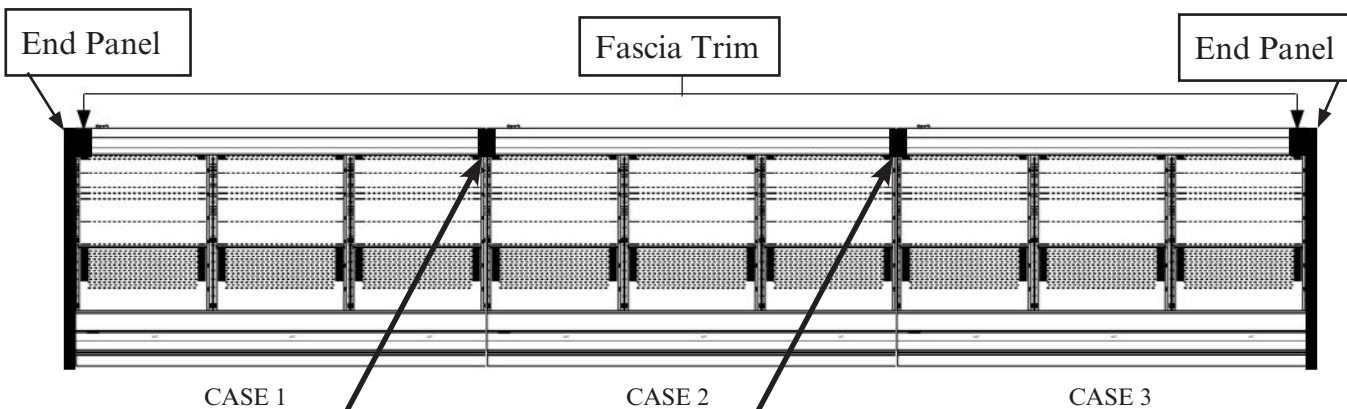

Optional Fascia Trim can be applied to case-to-case Fascia Joints

Fascia Panel Alignment

Applies to (IC2 / IC2X / IC3)

Fascia panel can slide toward the center of case lineups to eliminate gaps.

Fascia trim is then needed at the end of either side of the lineups to eliminate gaps at the ends.

1. Loosen the fascia screws located at the inner bottom of fascia.

2. Slide fascias toward the lineup center to eliminate gaps between fascias and tighten the screws.

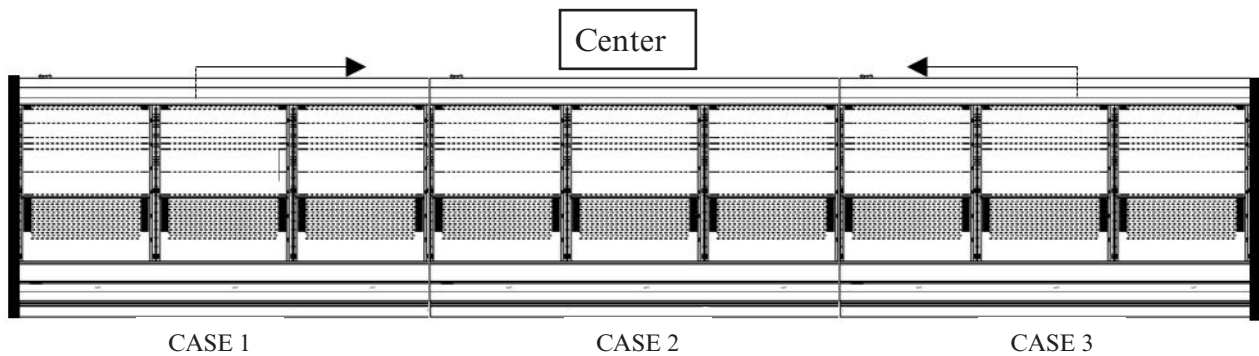

3. Place optional fascia trim between fascia joints between end panel and fascia and between case lineup joints. Install tape to joint first, then attach bottom and top fascia trim.

Front Panel Alignment

Front Panels can slide toward the center of (multideck) case lineups to eliminate gaps.

1. Loosen the front panel screws located at the bottom of Front Panel.
2. Slide front panel towards the lineup center to eliminate gaps between front panels. Tighten the screws after finishing the alignment.
3. Place optional front panel trim at case lineup joint. Install tape to joint first, then attach front panel trim.

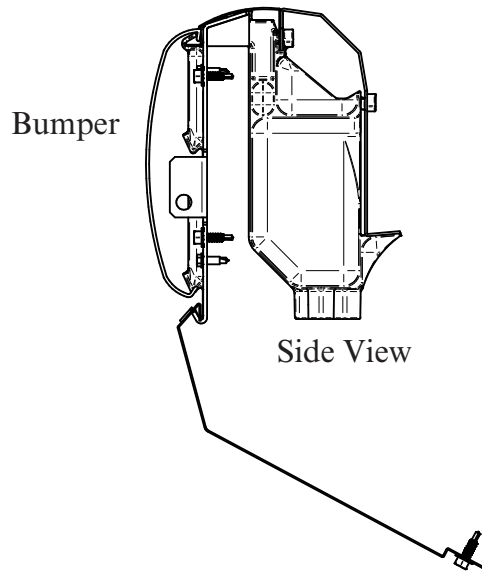

NOTE  Remove Front Skid Brace before aligning Front Panels. Align Panels before installing the Splashguard Front and Bumpers.

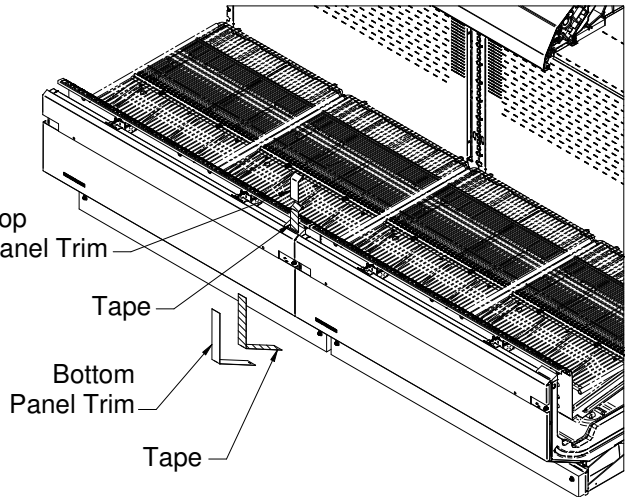

Front Panel Screw

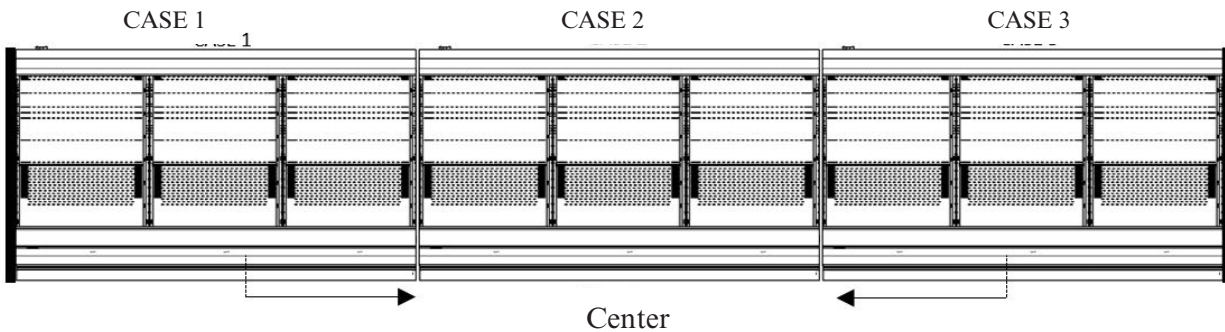

INSTALLING END SPLASHGUARDS
(Standard Case)

1. End splashguard must be slid in from the front, so that it fits behind the end panel. Attach end splashguard brackets to base at locations shown in the illustrations below.
2. Align forward edge of splashguard end panel to the inside of front splashguard. Fasten end splashguard to bracket with screws.
3. If end assembly bolt is loosened & seal broken when installing end splashguard, apply caulk to seal end assembly to inside of case.

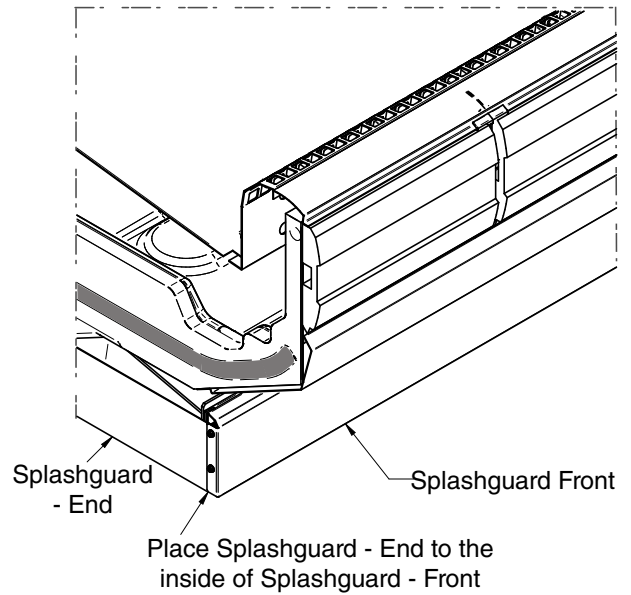

NOTE End Splashguard Panel fits to the inside of End Assembly.

IMPORTANT Install end splashguard before installing front splashguards.

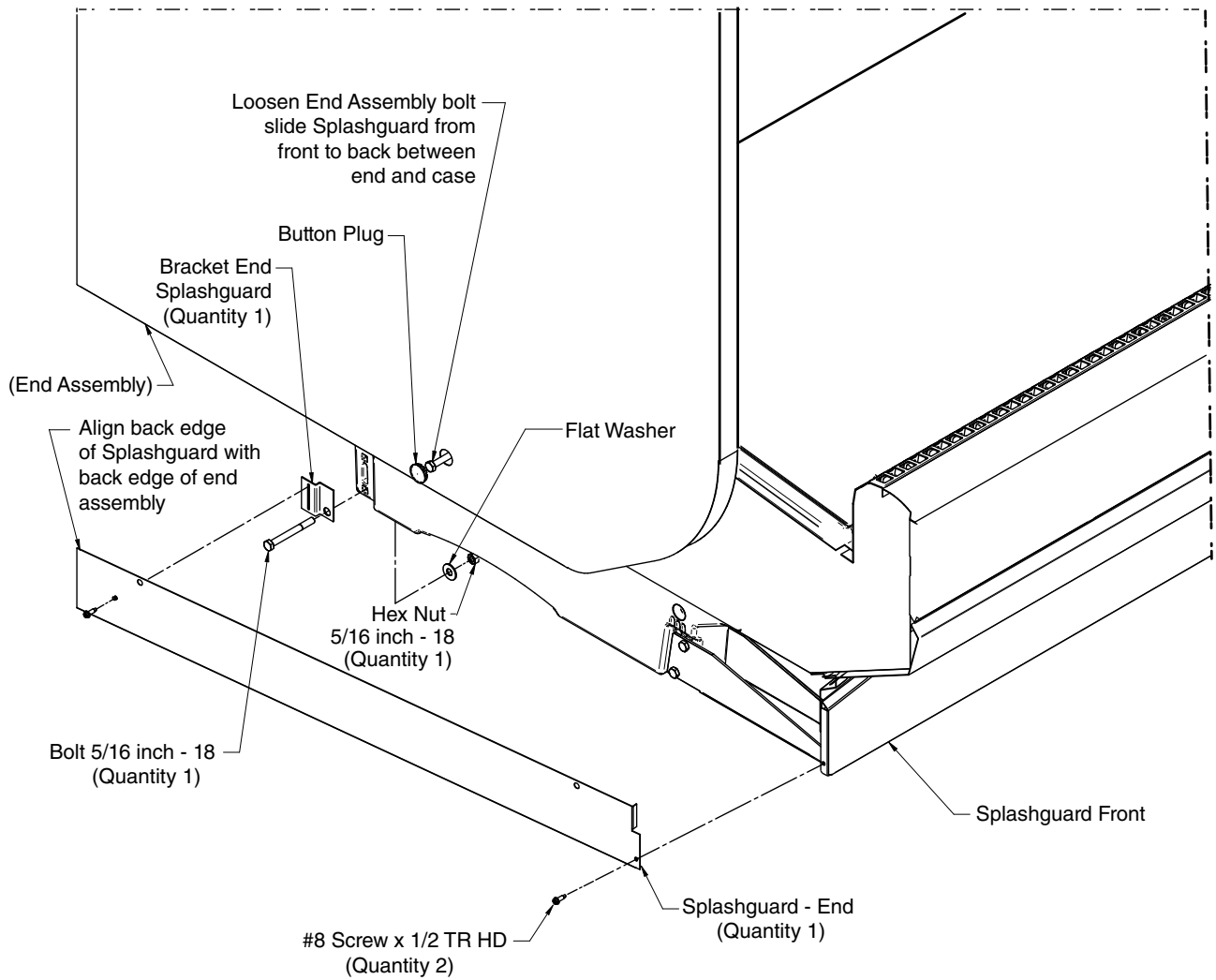

INSTALLING END SPLASHGUARD

(Detail below for cases with elevated case heights.)

1. End splashguard must be slid in from the front, so that it fits behind the end panel. Attach end splashguard brackets (2) to base at locations shown in the illustrations below.
2. Align forward edge of splashguard end panel to the inside of front splashguard. Fasten end splashguard to bracket with screws.

NOTE End Splashguard Panel fits to the inside of End Assembly.

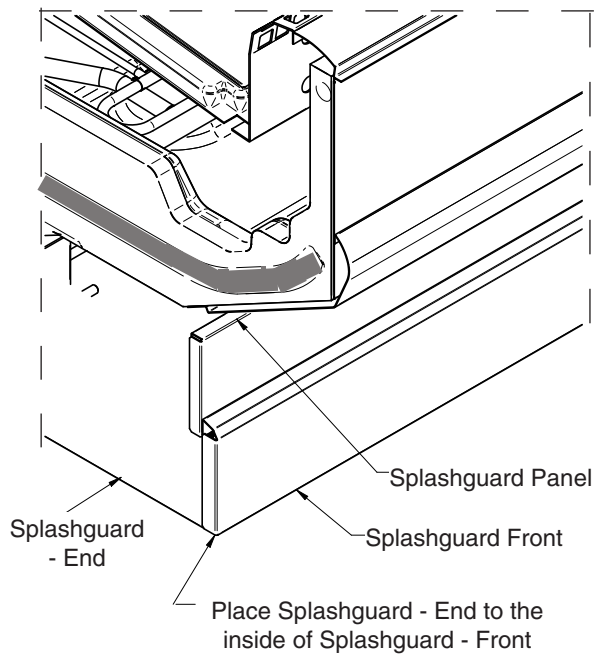

IMPORTANT Install end splashguard before installing front splashguards.

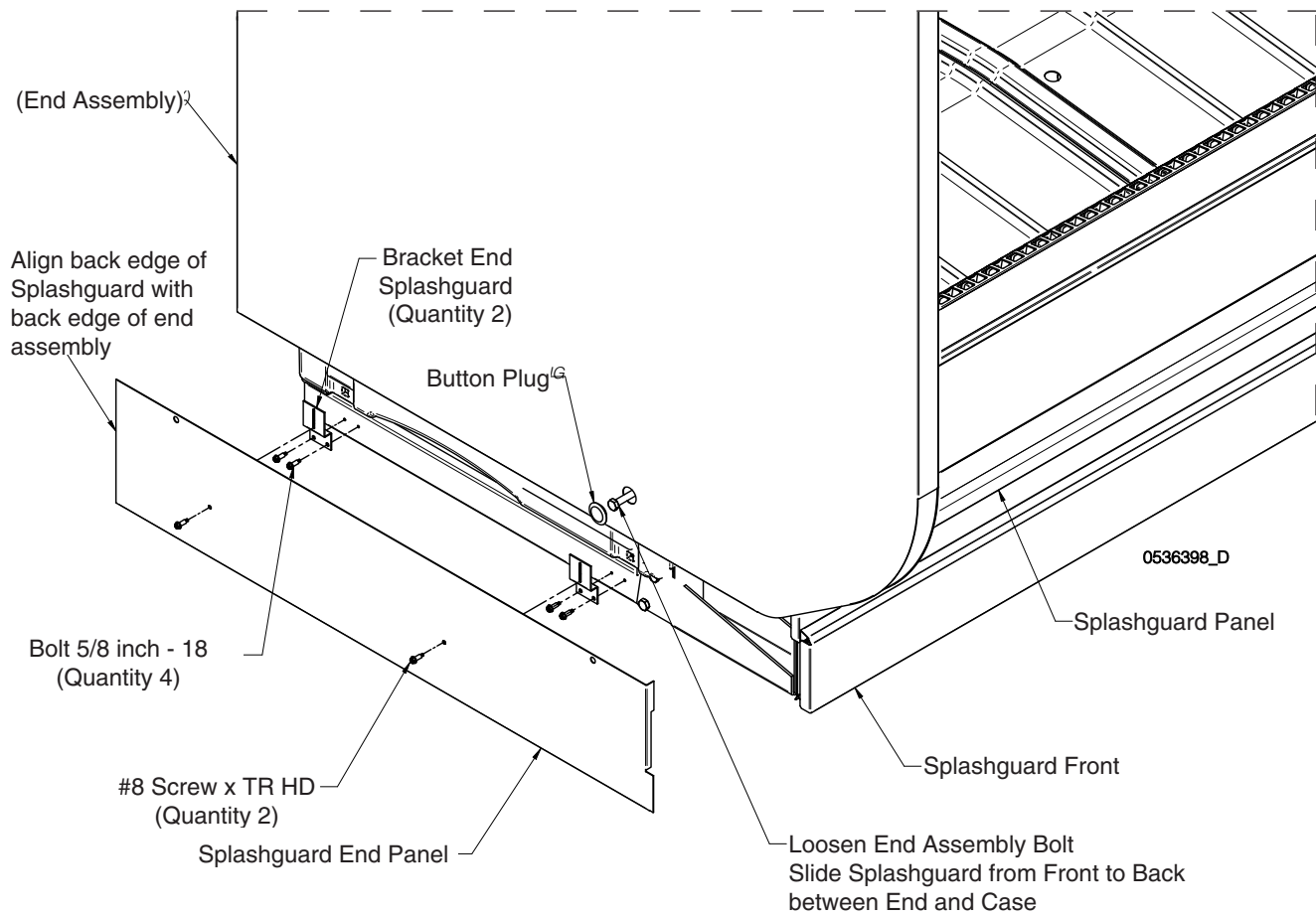

INSTALLING SPLASHGUARD BRACKETS

Position splashguard brackets at the front base (legs) of the merchandiser near the floor. Loosely assemble Splashguard Bracket using #8 x 5/8 inch SM screws as shown in Detail A below. More detail of splashguard installation shown on next page.

IMPORTANT
Install Drip Piping Before Installing Splashguards

⚠ WARNING

» Use caution when working around refrigeration lines or water lines. Damage to equipment and/or personal injury could occur.

Splashguard Bracket and Panel Installation (12 ft Shown)

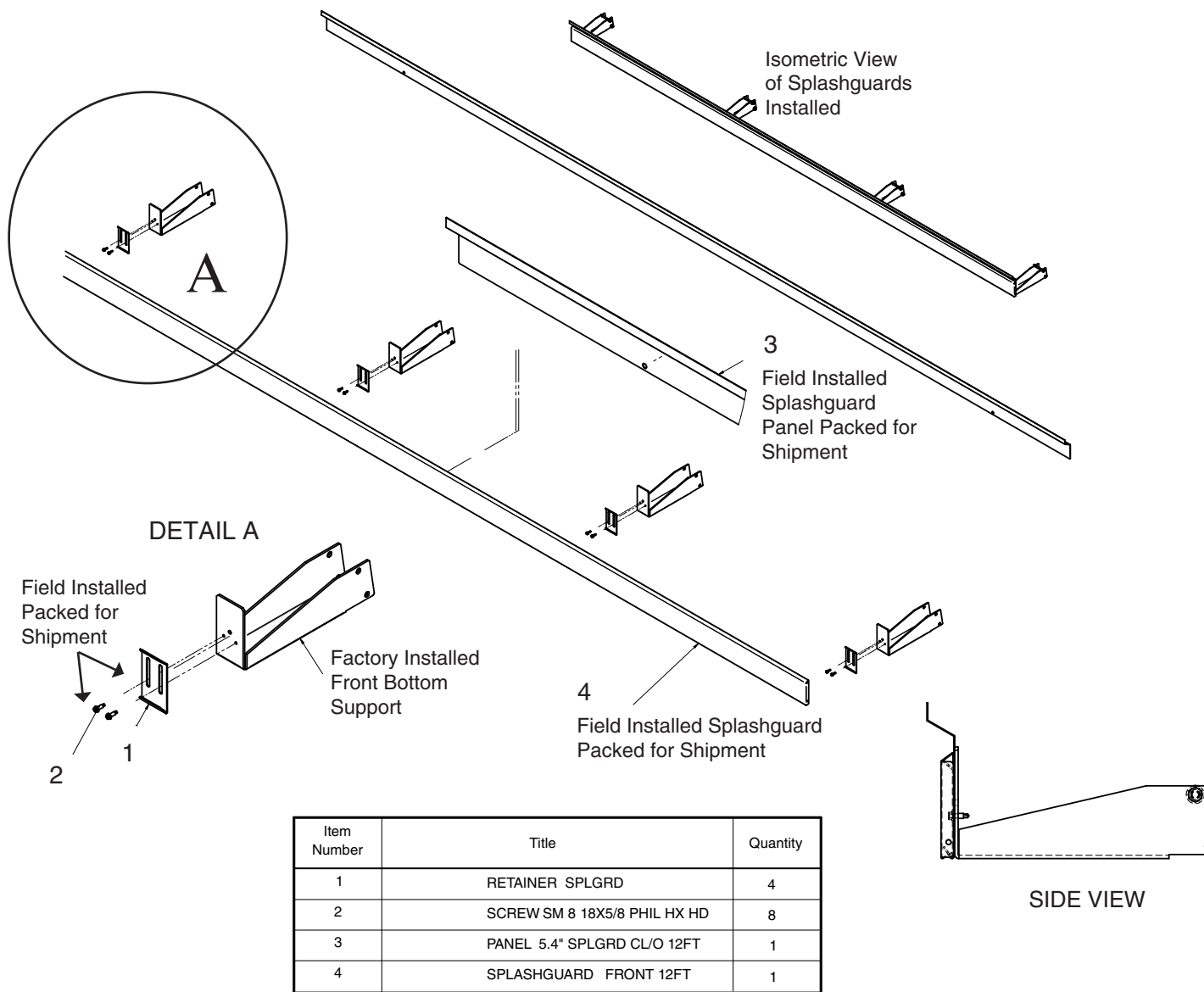

INSTALLING SPLASHGUARDS (Retainers and Panels)

Splashguards are shipped inside each merchandiser, 4 brackets for 12 ft case, 3 for 6 ft, etc. **AFTER** merchandisers have been leveled and joined, and all drip piping, electrical and refrigeration work has been completed, install the splashguard.

To Install Splashguards:

1. Check to be sure that all splashguard brackets are level with the floor. Refer to previous page for additional exploded view pictures.
2. Loosely attach the lower splashguard retainer bracket using # 8 SM screws (1).
3. Install close-off panel as shown in (2 & 3). Slide splashguard close-off panel between the bracket and lower front support.
4. Raise the splashguard close-off panel to where the top fits into bend on the lower color panel, then tighten the splashguard brackets.
5. Fit the lower splashguard into the slots on the lower splashguard retainer. Lower splashguard snaps into place (4).

To install OPTIONAL cove trim to the splashguard:

1. Remove all dirt, wax and grease from the area of the splashguard where adhesion will be necessary to ensure a secure installation.
2. Apply a good contact cement to the cove trim and allow proper drying time according to the directions supplied with the cement.
3. Install the trim to the splashguard so that it is lying flush with the floor. **DO NOT SEAL THE TRIM TO THE FLOOR.**
4. **If required by local health codes** the Cove Trim may be sealed to the floor, using a silicone type sealer. Sealant must be removed and replaced when servicing.

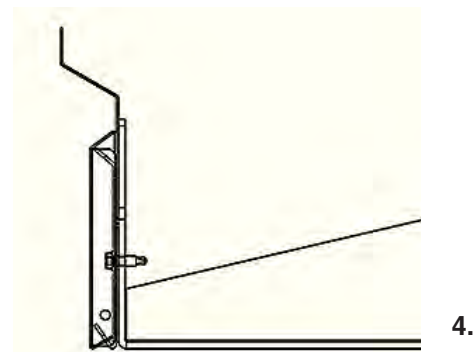
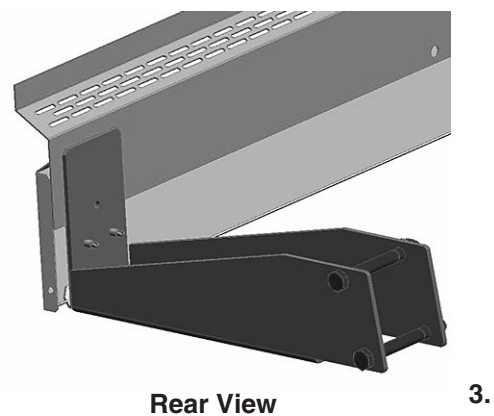
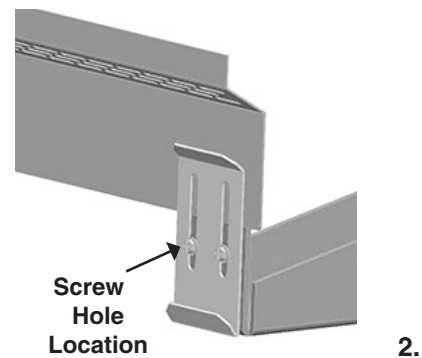
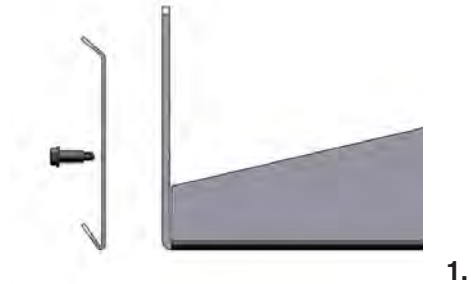

**SPLASHGUARD ALIGNMENT
TO ELIMINATE GAPS IN CASES LINE-UP**

1. Slide Splashguard towards line-up center to eliminate Splashguards gaps.

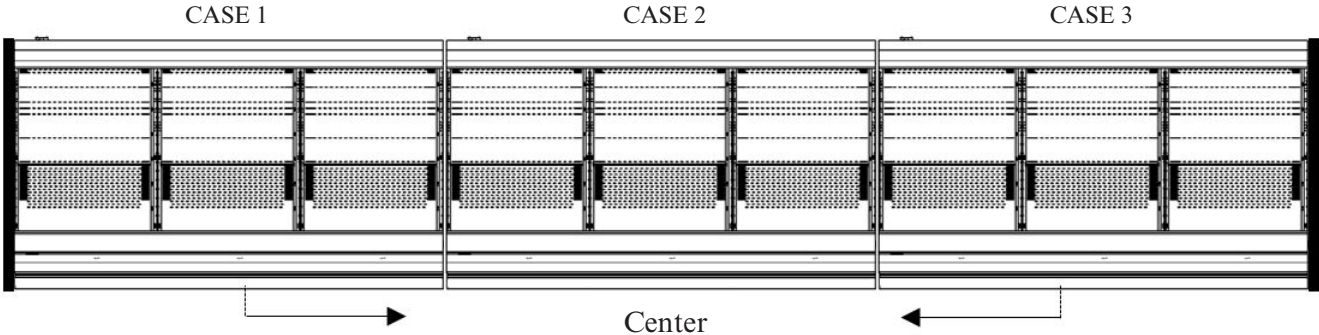

NOTES:

STARTUP / OPERATION

START UP / OPERATION

See the merchandiser’s Technical Data Sheet (TDS) for refrigerant settings and defrost requirements. Bring merchandisers down to the operating temperatures listed on the data sheet.

Excessive ambient conditions may cause condensation and therefore sweating of doors. Facility operators should monitor doors and floor conditions to ensure safety of persons.

Each four-foot section has its own evaporator coil and pre-set adjustable thermostatic expansion valve (TEV). Evaporator super heat must be checked on all cases during startup.

The TEV has been factory set to provide the recommended performance settings as specified on merchandiser data sheets. Only a certified technician should adjust these valves.

⚠ CAUTION

» Always be sure to replace TEV Cap, missing TEV Cap could result in refrigerant loss.

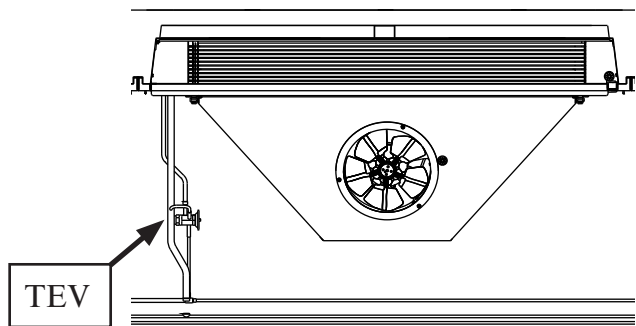

LOAD LIMITS

Each merchandiser has a load limit. Shelf life of perishables will be short if load limit is violated. At no time should merchandisers be stocked beyond the load limits indicated.

STOCKING

Do not block honeycomb or return air grille.

Product should not be placed inside of merchandisers until merchandiser is at proper operating temperature. Proper rotation of product during stocking is necessary to prevent product loss. Always bring the oldest product to the front and set the newest to the back.

Air discharge and return flues must remain open and free of obstruction at all times to provide proper refrigeration and air curtain performance. Do not allow product, packages, signs, etc. to block these grilles. Do not use non-approved shelving, baskets, display racks, or any accessory that could hamper air curtain performance.

⚠ WARNING

» Case ventilation openings must be clear of any obstructions. Do not damage the refrigerant circuit.

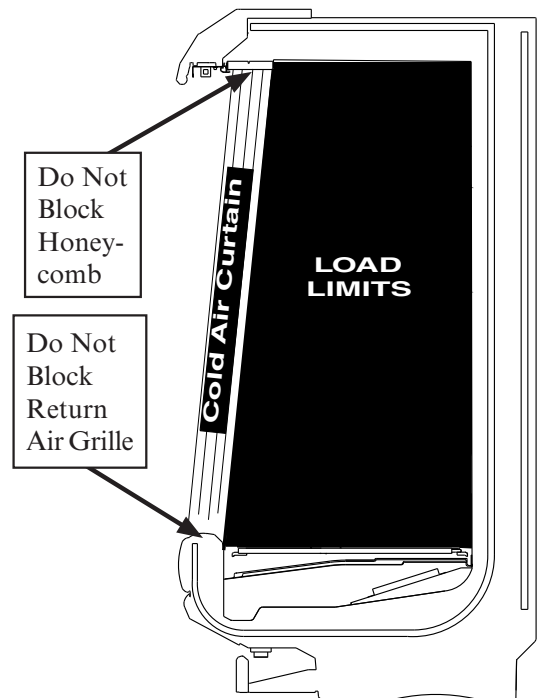

SHELF MAXIMUM WEIGHT LIMITS

Hussmann merchandiser shelves are designed to support the maximum weight load limits as indicated in this table.

Exceeding these maximum weight load limits may cause damage to the shelf or shelves, damage to the merchandiser, damage to store products, and potentially create a hazardous condition for customers and staff. Exceeding the indicated maximum weight load limits constitutes misuse as described in the Hussmann Limited Warranty.

Weight Limits for Merchandiser Shelving

Nominal Shelf Depth	Maximum Load Limit
12 in. (305 mm)	125 lb (56.7 kg)
14 in. (357 mm)	125 lb (56.7 kg)
16 in. (406 mm)	200 lb (90.7 kg)
18 in. (457 mm)	200 lb (90.7 kg)
20 in. (508 mm)	250 lb (113.4 kg)
22 in. (559 mm)	250 lb (113.4 kg)
24 in. (610 mm)	250 lb (113.4 kg)
Heavy Duty Beverage Shelf 16 in. (406 mm)	300 lb (136 kg)
Heavy Duty Beverage Shelf 18 in. (457 mm)	320 lb (145.1 kg)
Heavy Duty Beverage Shelf 20 in. (508 mm)	350 lb (158.8 kg)
Heavy Duty Beverage Shelf 22 in. (559 mm)	350 lb (158.8 kg)
Heavy Duty Beverage Shelf 24 in. (610 mm)	350 lb (158.8 kg)

*Shelf load limits at 0° tilt

Merchandiser Shelf Depths

	Recommended	Maximum
Narrow (37 in. Merchandiser Depths)	16 in. (406 mm)	18 in. (457 mm)
Standard (42 in. Merchandiser Depths)	22 in. (559 mm)	24 in. (610 mm)

MULTI-DECK SHELF CONFIGURATION

Shelves are individually mounted in 1 in. (25 mm) increments and have two-, three-, or four-position brackets, permitting shelves to be placed in a flat or down-tilt position (see illustration). Front product stops are recommended when shelves are placed in the down-tilt position.

Case performance will be degraded if peg shelves are used without baffles. Unauthorized specialty shelving may cause poor merchandiser performance. Consult your Hussmann representative to ensure optimum performance of Hussmann equipment.

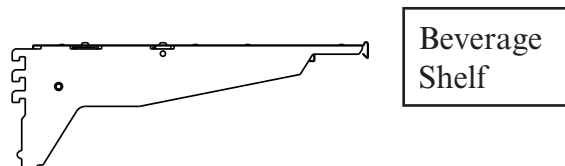
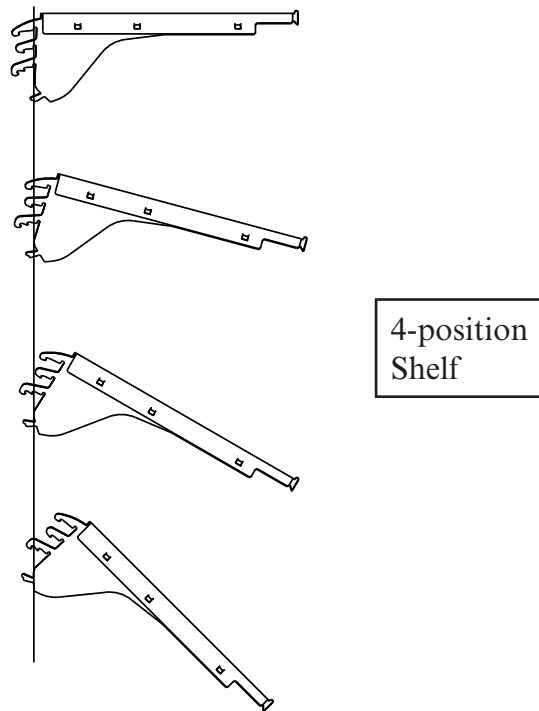

INSTALLING CASESHIELD PTM(S) (Optional)

The CaseShieldPTM is installed on the front edge of shelves as a replacement to existing price tag molding (PTM). It acts as a guide for the air from the discharge to the return air grille to reduce turbulence and save energy.

To install the CaseShieldPTM:

Slide the CaseShieldPTM onto the shelf as shown in **(B)** below.

NOTE: For use only with straight shelves. Do not apply CASESHIELD PTM(s) to angled shelves.

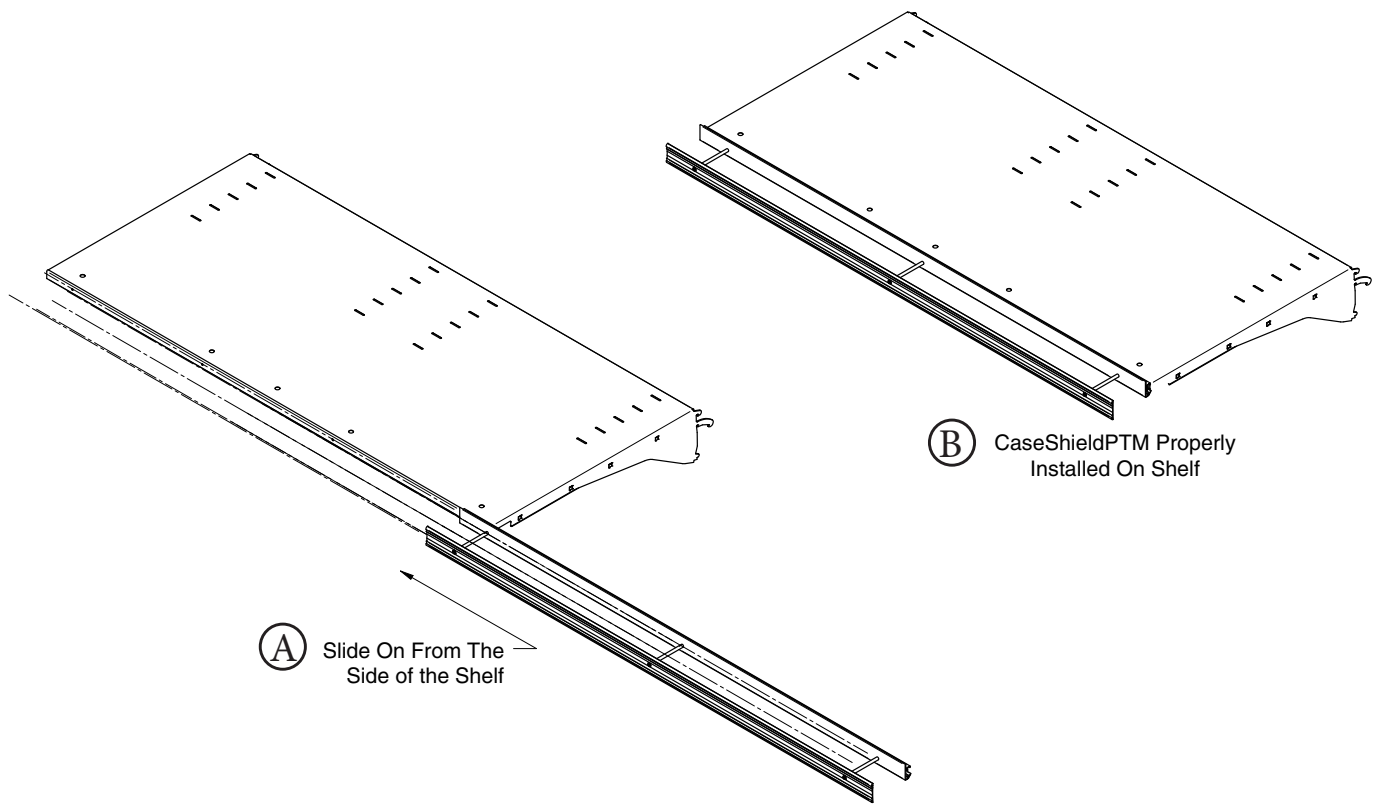
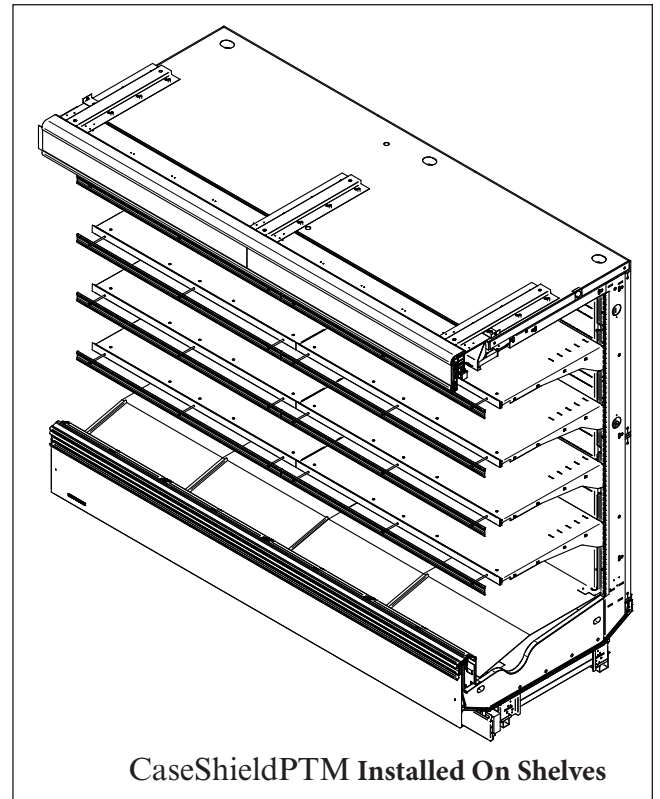

LED FIXTURES

These merchandisers are equipped with 24 volt DC power supplies that power the LEDs. The power supplies are located in the canopy wireway. EcoShine II LEDs work well for dimming or on/off operation using an occupancy sensor (optional kits).

They can be turned on and off in a cold environment with no warm-up time and no negative impact on lamp life. Hussmann EcoShine II LED light fixtures normally perform for more than 50,000 hours. Shelf lights are IP67 rated for water resistance. Canopy lights are IP54 rated for water splashes.

⚠ WARNING

— LOCK OUT / TAG OUT —

» To avoid serious injury or death from electrical shock, always disconnect the electrical power at the main disconnect when servicing or replacing any electrical component. This includes, but is not limited to, such items as doors, lights, fans, heaters, and thermostats.

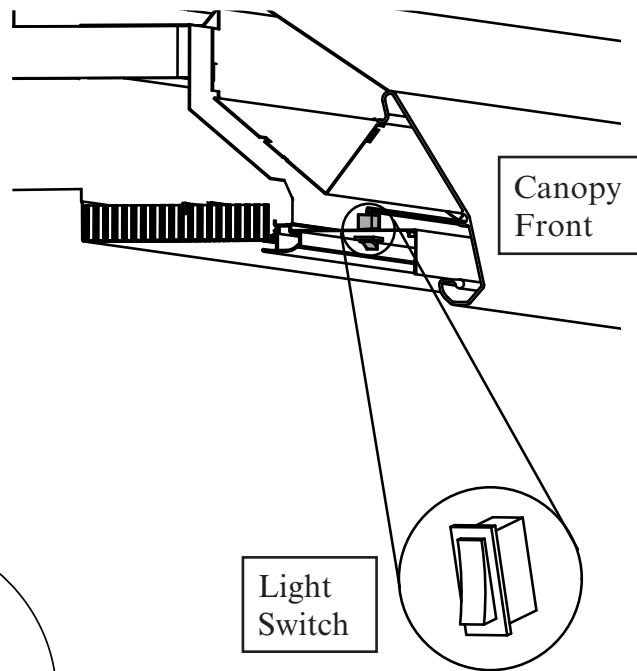
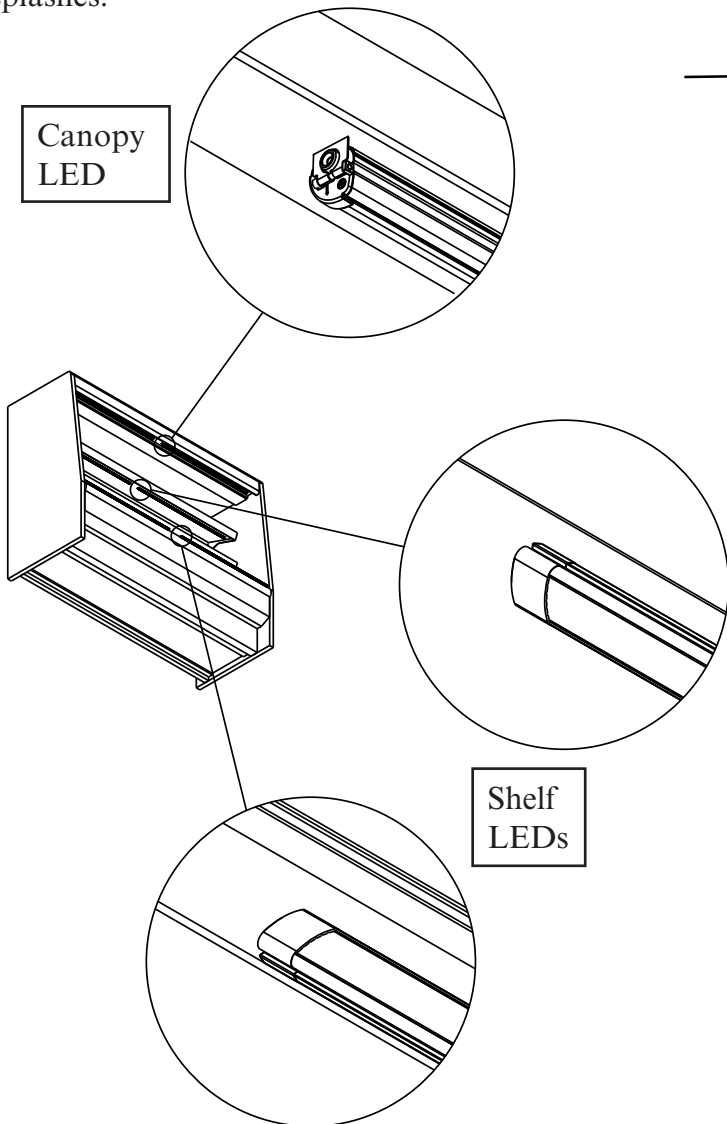

PROCEDURE FOR INSTALLING LIGHTED SHELVES

Follow these instructions to ensure good contact between male and female connectors.

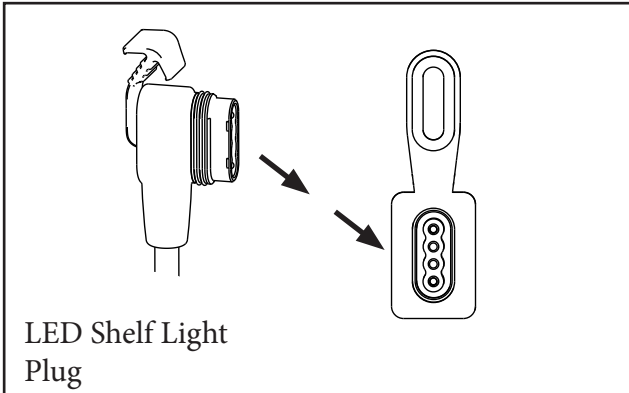

1. Remove any products from the case and place in cooler. Shut off power to the merchandiser.
2. Turn off Canopy Light Switch. Remove all packed shelves.
3. **Engage each power socket cap, and ensure that each cap is fully seated before cleaning.** Ensure the proper seating of the cap at all times when the plug is not engaged.

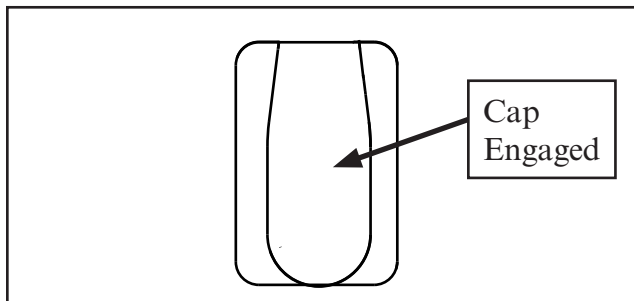

4. Clean the merchandiser as described in the *Care and Cleaning* paragraphs of **Section 5 — Maintenance**. **Keep liquid out of sockets.** (Allow merchandiser shelves to dry before turning on shelf power.)

5. Verify power to the merchandiser is turned ON. Verify that the merchandiser light switch is turned OFF. The switch is located in the canopy, on the left side.

6. Refer to the illustration at the top of the next page. Note that other models will have fewer rows of shelves. Starting from the left-hand bottom section, choose the location for the first shelf, X-1.

7. Secure the shelf in the slotted upright. Make certain that the shelf is level and that ends are in the same slot on the left and right upright. Markings on the shelf uprights indicate the proper shelf notch for each shelf location. It is important that shelf brackets be properly seated in the slotted upright.

8. Working from left to right, install the next shelf, X-2, to the right of the first shelf you installed. Always work from left to right and from the bottom up in each 8 ft (2438 mm) and 12 ft (3685 mm) merchandiser.

9. After each shelf on the bottom row is in position, be sure to remove the cap and insert the shelf connector. **Push firmly.**

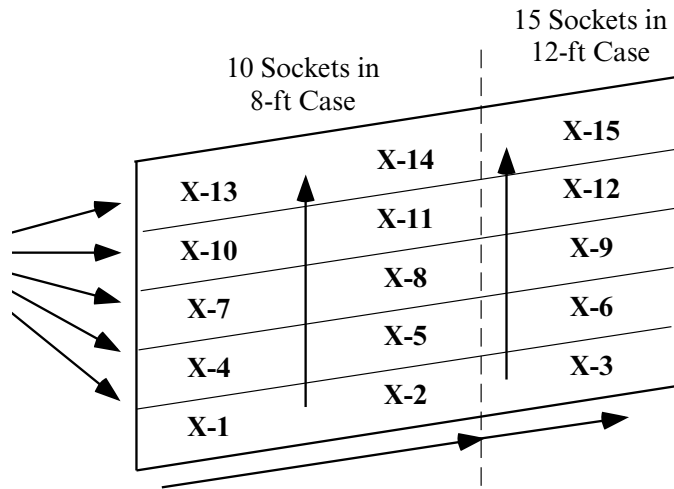

**Always work Left to Right,
and Bottom to Top**

10. Turn ON the merchandiser light switch after the entire bottom row has been installed in either 8 or 12 ft (2438 or 3658 mm) merchandisers. The shelf lights should light.

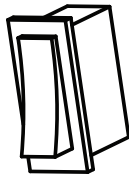

Note: Since the location for the remaining shelves, X-4 to X-15, may be directly over the rear wall receptacle, the shelf should be plugged in before engaging brackets in the uprights. The lower shelf will support the weight of the next shelf until it is plugged in. After installing each shelf, verify that its plug is properly connected to its rear wall receptacle. Continue working row by row, bottom up, left to right.

If an LED shelf light does not operate:

- Turn off light switch.
- Remove and firmly re-insert each shelf plug.
- Turn on light switch.

Important
If a shelf is plugged in and the lamp does not work, verify the case light switch is ON.

If lights do not operate after checking the items listed above, contact the installation contractor.

11. Using the row of shelves just installed as support, set the next shelf, X-4, in the desired location. Remove the cap and insert the shelf plug. Continue working left to right installing shelves X-5 and X-6.

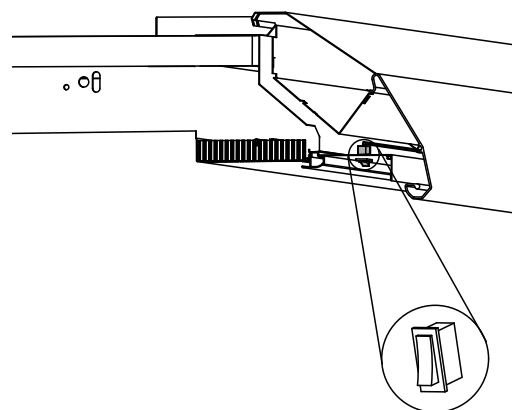

SHELF LED CLIP INSTALLATION

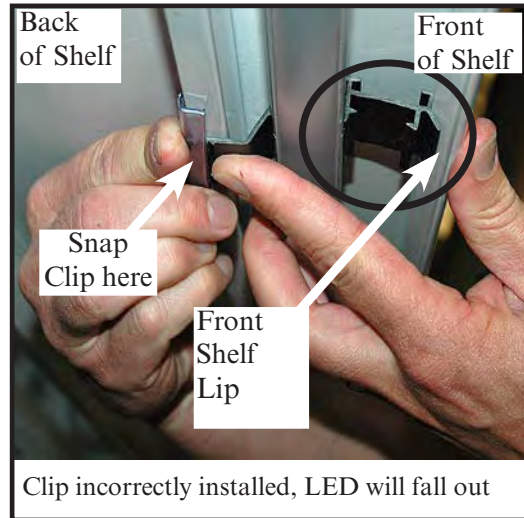
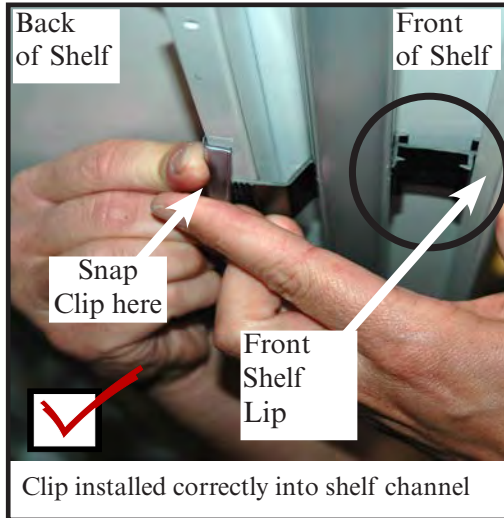

Shelf LED clips must be first inserted into the front lip underneath the shelf as shown at left. Next the retaining clip is “snapped on” to the rear of the LED clip.

PRODUCT STOP INSTALLATION

Use caution when installing Product Stops. Product stop legs must be inserted at an angle. When product leg goes through the shelf, it must rest **BEHIND** the LED shelf light as shown below.

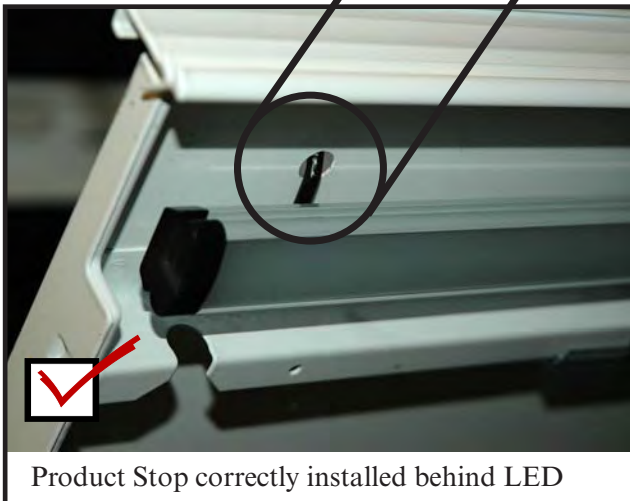

INSTALLING FDA/NSF REQUIRED THERMOMETER

The thermometer requirement does not apply to display refrigerators intended for bulk produce (refer to page 1-1). Please note that the tape cannot be exposed after installation.

This thermometer may not be required or provided in other countries. Check for local code requirements.

This is an NSF-7 & US FDA Food Code Required Thermometer

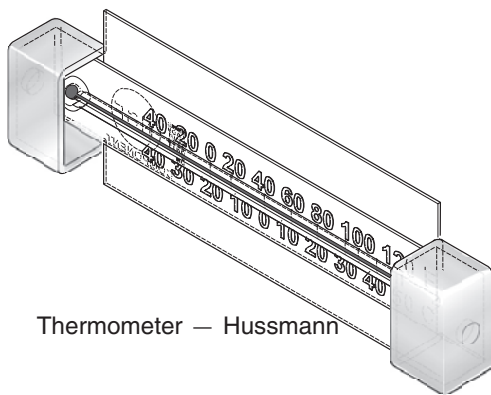

Thermometer — Hussmann

Hussmann Corporation • 12999 St. Charles Rock Road • Bridgeton, MO 63044-2483
 U.S. & Canada 1-800-922-1919 Mexico 1-800-890-2900 www.hussmann.com
 © 2013 • Hussmann Corporation

Suggested Mounting Locations in Single Deck Glass Front Merchandisers

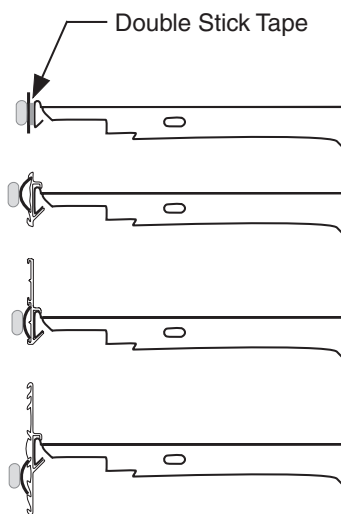
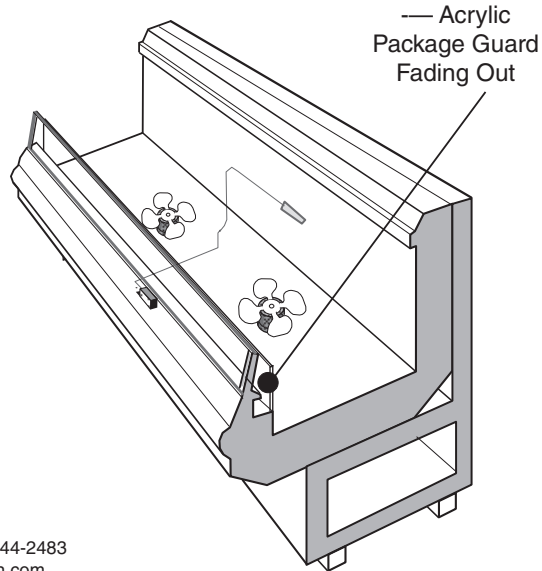

Flexible Plastic Fits in Price Tag Moldings

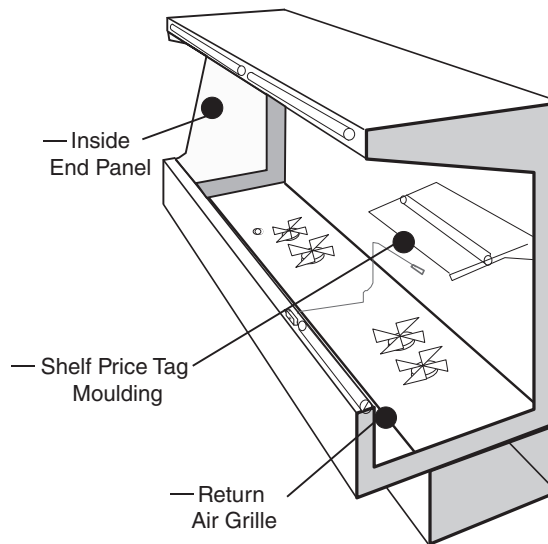

Suggested Mounting Locations in Multi-deck Merchandisers

Important – Please read!

This thermometer is provided in response to United States Food and Drug Administration (US FDA) Food Code [<http://www.fda.gov/>] and National Sanitation Foundation (NSF / ANSI) Standard 7 [<http://www.nsf.org/>]

Each installation will be different depending on how the unit is stocked, shopping patterns in the department and ambient conditions of the store. The suggested locations provided herein are possible locations. It is the responsibility of the purchaser / user to determine the location within the food storage area of the unit that best meets the code requirements above.

The thermometer may need to be moved several times to find the warmest location. Mounting options include flexible plastic for price tag molding application, magnet applied to back of flexible plastic for steel end wall, and double stick tape. Tape must not be exposed after installation.

Questions about either code should be addressed to local agencies or other appropriate officials.

**Keep with merchandiser
or give to store manager.**

DO NOT DESTROY.

NOTES:

MAINTENANCE

CARE AND CLEANING

Long life and satisfactory performance of any equipment is dependent upon the care it receives. To ensure long life, proper sanitation and minimum maintenance costs, these merchandisers should be thoroughly cleaned, all debris removed and the interiors washed down as part of a regular store sanitation schedule.

Fan Plenum

To facilitate cleaning, the fan plenum is hinged. After cleaning be sure the plenum is properly lowered into position or product loss will result due to improper refrigeration.

Fan motor harness plug must be securely connected. Do not disconnect fan motor harness plug for cleaning or maintenance procedures.

To lift the fan plenum:

1. Gently bend the bottom of the hinge pin arm away from the plenum to release the retainer from the coil support.
2. Rotate the hinge pin 180° so that the arm is pointed upwards.
3. Slide the hinge pin out and away from the plenum.

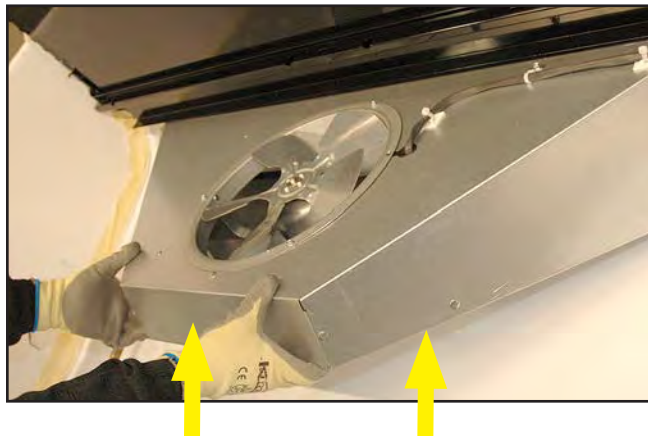

Lift up Fan Plenum. Use chain to hook up fan plenum to facilitate cleaning.

The plenum can also be removed, but this is not necessary for routine cleaning.

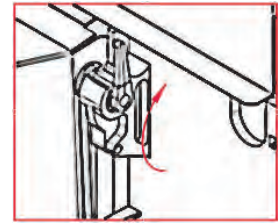
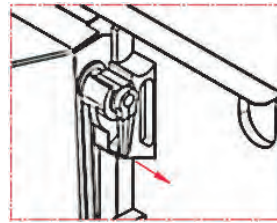

1. Flip the arm up and pull arm out to release the plenum.

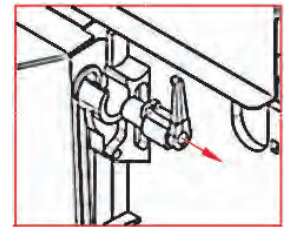

Removable Return Air Grilles

The return air grilles may be removed to facilitate cleaning. Lift a four foot section up and out as shown below.

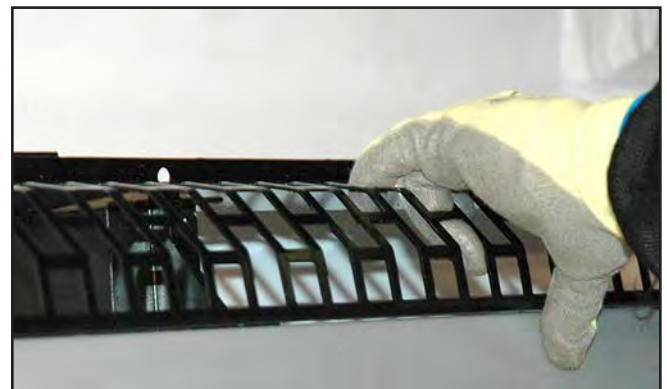

⚠ WARNING

- » All case cleaning and maintenance procedures should be performed with the power disconnected at the breaker.

IDENTIFICATION OF CASE PARTS

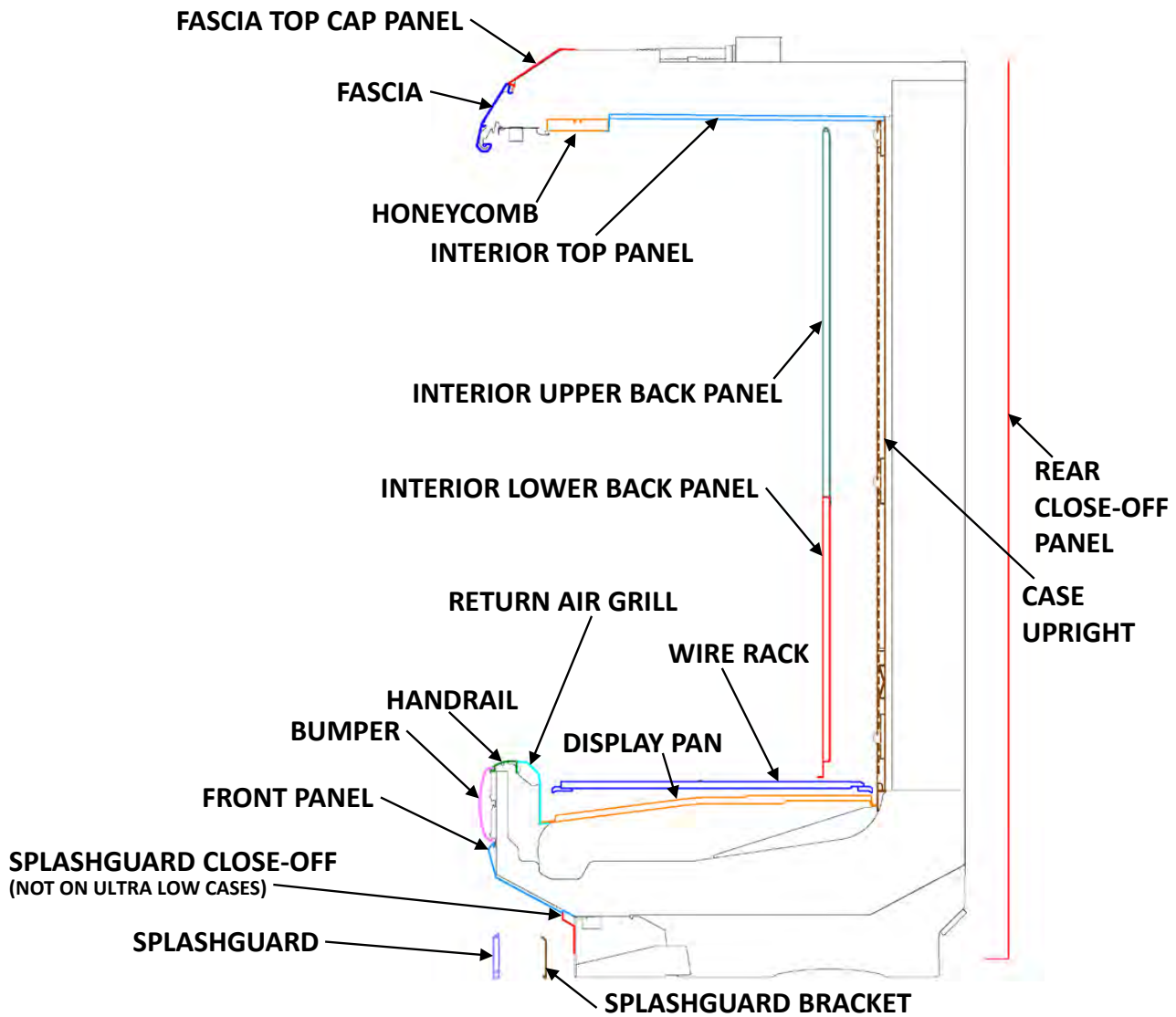

⚠ WARNING

» Do NOT allow cleaning agent or cloth to contact food product.

Fascia Panels

The exterior of the fascia panels should be cleaned with a mild detergent and warm water.

Do not use ammonia-based products to clean optional acrylic panels. Never use abrasive cleansers or scouring pads.

EXTERIOR SURFACES

The exterior surfaces must be cleaned with a mild detergent and warm water to protect and maintain their attractive finish.

NEVER USE ABRASIVE CLEANERS OR SCOURING PADS.

INTERIOR SURFACES

The interior surfaces may be cleaned with most domestic detergents, ammonia based cleaners and sanitizing solutions will not harm the surface. Always read and follow the manufacturer's instructions when using any cleaning product.

Inspect all LED connections and plug/ receptacles for signs of arcing. Replace any component that shows signs of arcing. Make sure all unused receptacles have close-off covers securely attached.

Do Not:

- Abrasive cleansers and scouring pads, as these will mar the finish.
- Coarse paper towels on coated glass.
- Ammonia-based cleaners on acrylic parts.
- Do not spray water from a hose directly on the canopy lights or fans.
- Solvent, oil or acidic based cleaners on any interior surfaces.

• A pressure nozzle on canopy lights, shelf lights or any other electrical connection. Do not use water pressure beyond what is supplied from the potable water system and spray nozzle (ie Do not use a pressure washer.)

Steps:

- First turn off refrigeration, then disconnect electrical power. Turn off case power at breaker. Make sure all unused light receptacles have their close-off covers securely attached.
- Remove the product and all loose debris to avoid clogging the waste outlet.
- Store product in a refrigerated area such as a cooler. Remove only as much product as can be taken to the cooler in a timely manner.
- Thoroughly clean all surfaces with soap and warm water. Do not use steam or high water pressure hoses to wash the interior. These will destroy the merchandisers' sealing causing leaks and poor performance.
- Lift hinged fan plenum for cleaning. Hook chain in rear panel to secure plenum during cleaning. Be sure to reposition the fan plenum after cleaning merchandiser.
- Take care to minimize direct contact between fan motors and cleaning or rinse water.
- Rinse with warm water, but do not flood. Never introduce water faster than the waste outlet can remove it.
- Allow merchandisers to dry before resuming operation.
- Wipe down lighted shelves with a damp sponge or cloth so that water does not enter the light channel.
- After cleaning is completed, turn on power to the merchandiser.

RECOMMENDED CLEANING INSTRUCTIONS

The directions below are recommended cleaning instructions for Insight cases and should not be used as a substitute for the store's regular maintenance schedule. Follow all local and national health codes. Cleanliness of the case encourages long-lasting life of the equipment. This guide lists some of the key areas of the cases that require cleaning to help maintain the overall appearance and performance of the equipment and keep it free of debris. The cases may need additional cleaning, especially in high traffic areas, dusty areas and during unusually extended periods of use of the equipment.

Rotate the type of detergent and sanitizer used. For example, rotate the use of an ammonia based, a chlorine based and/or a peroxide based detergent and sanitizer to ensure micro-organisms do not become resistant to a single detergent or sanitizer.

CLEANING INSTRUCTIONS

Weekly or Monthly

1. Remove product; store it in another case or suitable walk-in cooler.
2. Remove wire racks and bottom pans. Cleaning them in the case with warm water and a soap solution, then rinse and set aside.
3. Turn off case power at breaker.
4. Flip up the fan plenum assembly to provide more room for cleaning in the case if necessary.
5. Remove all loose debris and food particles that may clog drain. Check drain to make sure it is not clogged. Do not force items down drain, use the drain catch to remove debris and dispose.

6. Remove honeycomb and price display molding.
7. Clean all surfaces including shelves and honeycomb by spraying down water (preferably warm) and mild detergent. Use a brush or cleaner pad if necessary to aid in penetrating dirt.
8. Rinse all surfaces with water, then spray with a sanitizer. Rinse off sanitizer with clean water using a hose. Allow surfaces to air dry, since wiping would defeat the purpose of sanitizing.
9. Replace all internal parts carefully so that they seat properly. This is necessary for proper case operation.
10. Turn ON power to the fans at breaker.
11. Replace product.

CLEANING INSTRUCTIONS

Quarterly or Semiannually

1. Remove product; store it in another case or suitable walk-in cooler.
2. Remove wire racks and bottom pans. Cleaning them in the case with warm water and a soap solution, then rinse and set aside.
3. Turn off case power at breaker.
4. Flip up the fan plenum assembly to provide more room for cleaning in the case if necessary.
4. Remove all loose debris and food particles that may clog drain. Check drain to make sure it is not clogged. Do not force items down drain, use the drain catch to remove debris and dispose.
5. Remove honeycomb and price display moulding.

6. Clean all surfaces including shelves and honeycomb by spraying down water (preferably warm) and mild detergent. Use a brush or cleaner pad if necessary to aid in penetrating dirt.
7. Remove all the shelves and set aside then remove the back panels.
8. Clean the backside of the back panels in the case as you remove them.
9. Clean the newly exposed surfaces and the coil by spraying down with water (preferably warm) and a mild detergent solution.
10. Rinse the newly exposed surfaces and the coil with water then spray with a sanitizer. Allow surfaces to air-dry, since wiping would defeat the purpose of sanitizing.
11. Replace the back panels and shelves.
12. Rinse all surfaces with water, then spray with a sanitizer. Allow surfaces to air-dry since wiping would defeat the purpose of sanitizing.
13. Replace all remaining internal parts carefully so that they seat properly. This is necessary for proper case operation.
14. Turn ON power to the fans at breaker.
15. Replace product.

⚠ WARNING

- » Do not use mechanical devices or other means to accelerate the defrosting process.
- » Do not use electrical appliances inside the food storage compartments of the case(s).

CLEANING HONEYCOMB ASSEMBLIES

Honeycombs should be cleaned every six months, or depending on store environment the honeycombs may need to be cleaned more often. Dirty honeycombs will cause cases to perform poorly.

The honeycombs may be cleaned with a vacuum cleaner. Soap and water may be used if all water is removed from the honeycomb cells before replacing. Be careful not to damage the honeycombs.

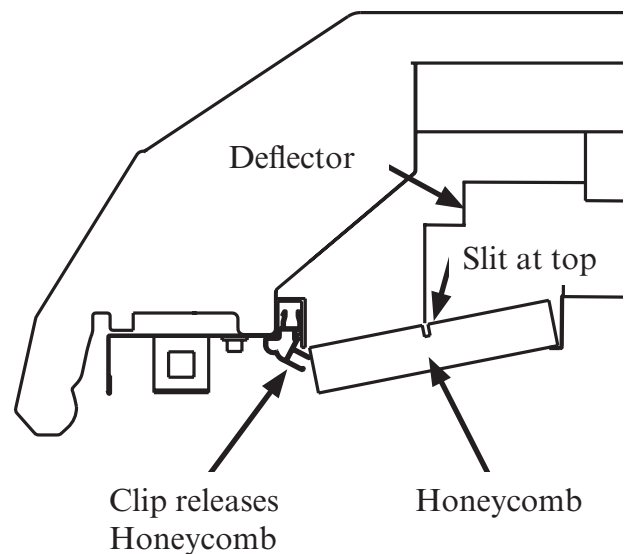

1. Remove honeycomb by pulling clip as shown above.
2. Clean and dry the honeycomb.
3. Honeycomb is symmetrical.
4. After cleaning, replace honeycomb. Ensure clip is centered and engaged along full-length of honeycomb.

Damaged honeycomb must be replaced.

CLEANING MIRRORS

Mirrors are sheets of clear glass that have very thin reflective and protective coatings applied to one side. These coatings are susceptible to deterioration if certain cleaning solutions and even water are allowed to come in contact with them. Every precaution should be taken to keep all liquids away from the coated side of the mirrors. **IF LIQUIDS ARE ALLOWED TO FLOW ALONG THE FACE SIDE OF THE MIRROR TO ITS EDGE, THE LIQUID CAN SEEP UP BETWEEN THE COATING AND THE GLASS, CAUSING SERIOUS DAMAGE.**

To Help Prolong the Life of the Mirrors:

- Use only mild cleaning solutions that do not leave residue, such as a weak (10%) solution of vinegar and water.
- Do NOT spray liquids on the mirrors. Away from food, dampen the cleaning cloth, then use the cloth to wipe the mirror.
- Wipe water from the mirrors immediately to prevent difficult to remove water spots and also to prevent the water from reaching the mirror's edge.
- Never use dirty cloths, scrapers or any other abrasive materials for cleaning.

▲WARNING

- » Product will be degraded and may spoil if allowed to sit in a non-refrigerated area.
- » All products in the case should be removed and stored in a cooler at the appropriate temperature before cleaning the interior of the case.

REMOVING INTERIOR BACK PANELS

The interior back panels may be removed for cleaning and to gain access to the evaporator coils. Remove the rear interior back panels as follows:

1. Disconnect the electrical power to the merchandiser.
2. Unplug shelf lights and insert plastic protective cap. Remove shelving.
3. Remove the lower panel first: lift the panel up, then pull forward and out.
4. Remove the top panel.



5. Replace panels in reverse order, starting with the top panel.

BOTTOM LINER REPAIR

Insight merchandisers have bottom liners, which are made of a high density polyethylene material (HDPE). Repairs may be made if the bottom liner becomes damaged. Follow the illustrations at right to repair the liner.

For minor repairs:

Minor repairs consist of deep scratches and tears that are no more than 1/8 inch thick.

1.) Remove all product, and disconnect power to the case that is to be serviced. Locate the damaged area of the liner. Clear and clean the area, then wipe it dry.

2.) Use an electric hot air gun to heat the tear. **Heat to 600°F (316°C)**. Solder the tear with 1/8 inch filler welding rod, made from HDPE. Ensure no voids or skips in completed bead.

3.) Let the area cool, then buff the area flat. A 5-inch, 80 grit disc works well for this. The repair is now complete.

For major repairs:

1.) For repairs with larger size gashes or holes, a piece of HDPE may be cut into a square as shown in **(F)** at right. (The square HDPE shown in the photo is white for clarity.)

2.) Remove all product and disconnect power to the case that is to be serviced. Locate the damaged area of the liner. Clear and clean the area, then wipe it dry. Ensure no voids or skips in completed bead.

3.) The square is then tacked at all four corners using the hot air gun.

4.) Solder with 1/8 inch filler welding rod around the perimeter of the HDPE square.

5.) Buff the area flat if needed. The repair is now complete.

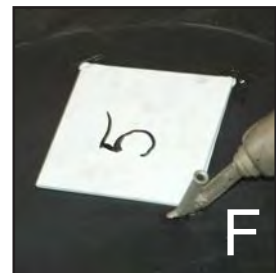
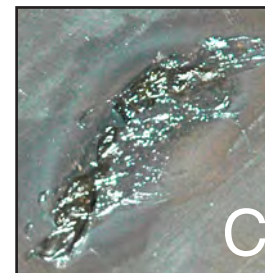
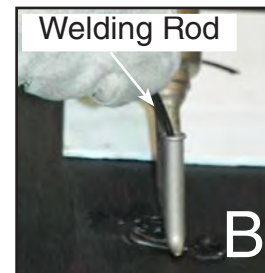
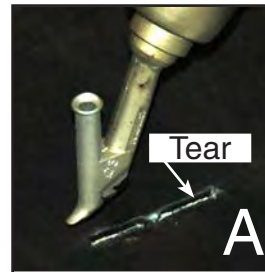

Forthoff Mini Electric Hot Air Gun
(120V 1300W)

**⚠ WARNING**

- » Always wear protective clothing when operating hot air gun, such as fire resistant gloves and arm guards. Hot air gun operates at extremely high temperature and could cause serious burns. Always have fire protective gear on hand in case of fire.
- » To avoid serious injury or death from electrical shock, always disconnect the electrical power at the breaker when servicing or replacing any electrical component. This includes, but is not limited to, such items as doors, lights, fans, heaters, and thermostats.

CLEANING COILS

NEVER USE SHARP OBJECTS AROUND COILS!

Use a soft brush or vacuum brush to clean debris from coils. *Do not puncture coils!* Do not bend fins. Contact an authorized service technician if a coil is punctured, cracked or otherwise damaged.

ICE in or on the coil indicates the refrigeration and defrost cycle is not operating properly. Contact an authorized service technician to determine the cause of icing, and to make adjustments as necessary. To maintain product integrity, move all product to a cooler until the unit has returned to normal operating temperatures.

CLEANING STAINLESS STEEL FRONT RAILS

Use non-abrasive tools, and always polish with grain of the steel.

Use alkaline chlorinated or non-chlorine containing cleaners. Do not use cleaners containing salts as this may cause pitting and rusting of the stainless steel finish.

Clean frequently to avoid build-up of hard, stubborn stains. Rinse and wipe dry immediately after cleaning. Never use hydrochloric acid (muriatic acid) on stainless steel.

REMOVING SCRATCHES FROM BUMPER

Most scratches and dings can be removed using the following procedure.

- Use steel wool to smooth out the surface area of the bumper.
- Clean area.
- Apply vinyl or car wax and polish surface for a smooth glossy finish.

CLEANING UNDER MERCHANDISERS

Remove splashguards not sealed to floor. Use a vacuum with a long wand attachment to remove accumulated dust and debris from under the merchandiser.

WARNING

- » Do not use HOT water on COLD glass surfaces. This can cause the glass to shatter and could result in personal injury. Allow glass fronts, ends and service doors to warm before applying hot water.

SERVICE

REPLACING FAN MOTORS

Fan control electronics are electrostatic sensitive (ESD). If the case is equipped with an optional fan speed selector (FSS), use a grounding kit before handling.

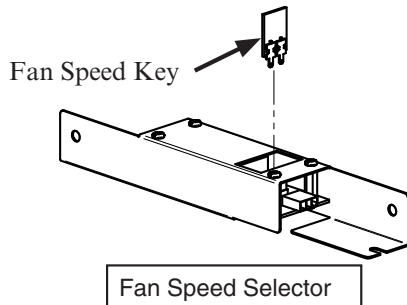

⚠ WARNING

— LOCK OUT / TAG OUT —

» To avoid serious injury or death from electrical shock, always disconnect the electrical power at the main disconnect when servicing or replacing any electrical component. This includes, but is not limited to, such items as doors, lights, fans, heaters, and thermostats.

See cross section for location of evaporator fans. Should it ever be necessary to service or replace the fan motors or blades be certain that the fan blades are re-installed correctly.

To access and replace fan motor:

1. Turn off case power at breaker.
2. Remove bottom display pans.
3. Unpack new motor/harness assembly and set aside outside of case.
4. Remove screws holding existing fan motor bracket assembly to plenum, and remove assembly from plenum.
5. Unlock and Unplug existing motor harness from harness; remove existing motor.
 - A. Rotate locking ring counterclockwise to unlock.
 - B. Pull connector straight out to disengage.
6. Taking care to avoid any existing moisture in the case, IMMEDIATELY connect and lock new motor harness as follows:



Correct connection procedure for main fan motor harness connector:

- A. Align arrows and push connector into position.
- B. Rotate locking ring until all three arrows are aligned in the secured position.

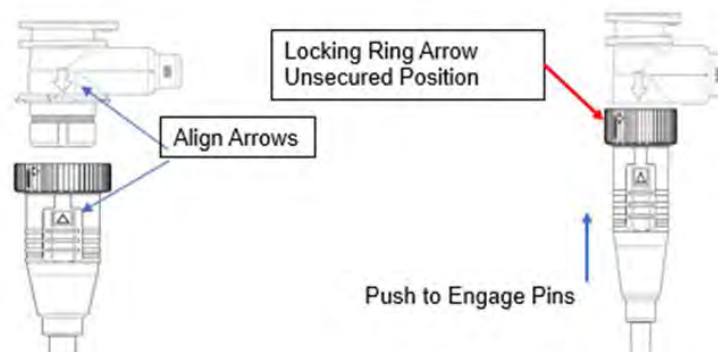

- C. Push straight in to engage pins.
- D. Turn locking ring until all three arrows are aligned.

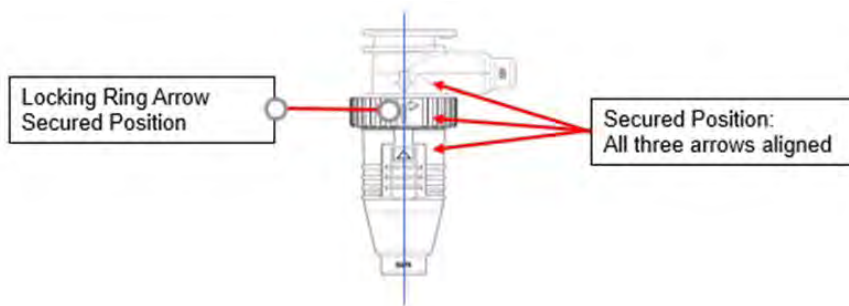

Remember. Push to engage, then twist to secure.

⚠ WARNING

STOP - DO NOT UNPLUG

The fan motor harness plug **MUST** be properly secured in order to perform at its IP67 rating. The component is a twist lock style connector with an alignment arrow to validate a secure connection. This connection should **ONLY** be disconnected / connected by a qualified contractor and **ONLY** in the event of a fan motor replacement. The fan motor harness plug should not be disconnected/connected in performing any other cleaning, service or repair. Refer to the installation, operation and services manual for sequence of repair. All case cleaning & maintenance procedures should be performed with the power disconnected at the breaker. Failure to adhere to these instructions can lead to damage to the unit and creates a risk of flammability.

7. Place new fan motor assembly back into plenum, and reinstall screws to secure.
8. Turn on power.
9. Verify that motor is working and blade is turning in the correct direction.
10. Close air gaps under fan plenum. Warmer air moving into refrigerated air reduces effective cooling. If the plenum does not rest against the case bottom without gaps, apply foam tape to the bottom of the fan plenum to reduce improper air movement. Use silicone sealant to close other gaps.
11. Replace display pans. Bring merchandiser to operating temperature before restocking.

REPLACING DOOR HANDLES

These doors have glued on studs. If the handle is broken it should be replaced along with the stud.

1. Use a razor blade to remove the excess glue from the door. Only replace the stud that is damaged.
2. Clean the glass surface. Apply isopropyl alcohol to the surface of the glass and wipe using a paper towel until dry.
3. Clean the surface of the stud. Apply isopropyl alcohol to the surface to the stud and wipe using a paper towel until dry.
4. Apply Loctite SF 7387 to the bottom flat surface of the stud and wait 30 seconds or until dry.

Tools and Supplies Needed:

EcoVision Stud: P/N 3119359

Glue: Loctite AA 392

Activator: Loctite SF 7387

Razor

Hammer, if needed

Template

Isopropyl Alcohol

Paper Towels

Tape

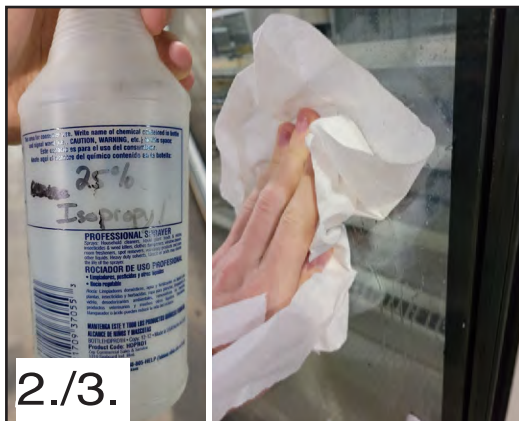

5. Place the stud template in the correct orientation/location and secure to surface of the door.

Ensure tape does not leave residue when removed. Painter's tape and 3M 8898 are the suggested choice of tape to use.

6. Apply a drop of Loctite AA 392 to the center of the stud.
7. By hand, firmly press the stud to the glass for 15 seconds.



8. Carefully remove the stud template from the door and wait 5 minutes to allow the glue to cure fully.
9. Carefully wipe away any excess glue/ activator from glass surface and clean using isopropyl alcohol.

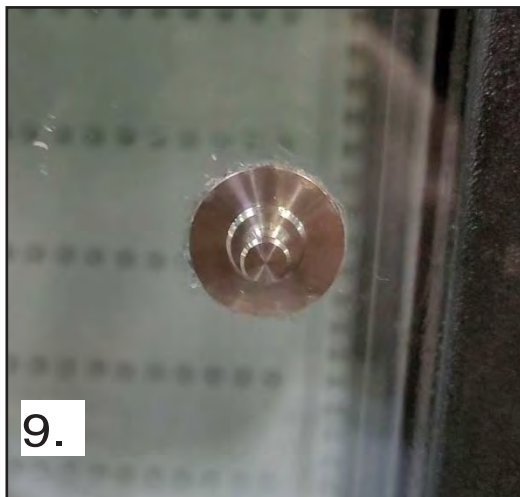
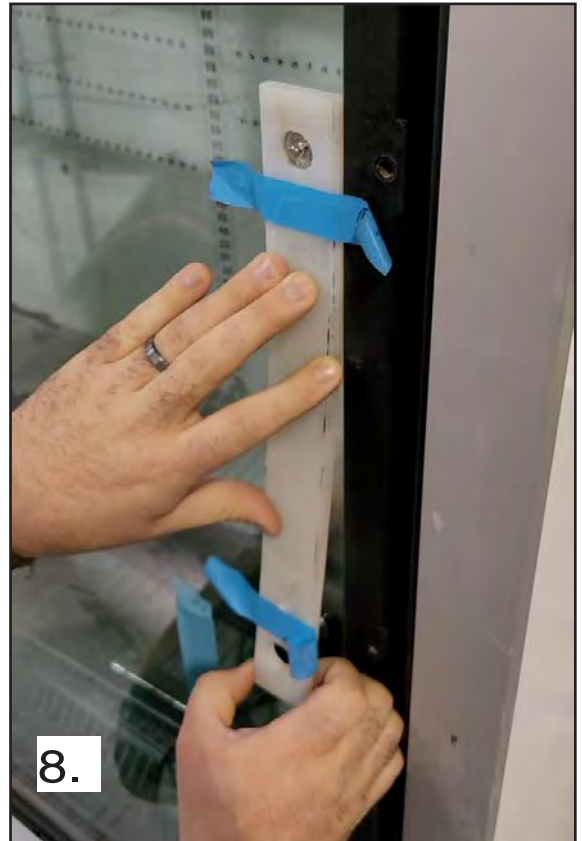

REPAIRING ALUMINUM COIL

The aluminum coils used in Hussmann Insight merchandisers may be easily repaired in the field. Materials are available from local refrigeration wholesalers.

Hussmann recommends the following solders and technique:

Solders

Aladdin Welding Products Inc.

P.O. Box 7188

1300 Burton St.

Grand Rapids, MI 49507

Phone: 1-800-645-3413

Fax: 1-800-645-3414

X-Ergon

1570 E. Northgate

P.O. Box 2102

Irving, TX 75062

Phone: 1-800-527-9916

NOTE:

Hussmann Aluminum melts at 1125°F (607°C)

Aladdin 3-in-1 rod at 732°F (389°C)

X-Ergon Acid core at 455°F (235°C)

Technique:

1. Locate Leak.
2. REMOVE ALL PRESSURE.
3. Brush area UNDER HEAT.
4. Use PRESTOLITE TORCH ONLY. Number 6 tip.
5. Maintain separate set of stainless steel brushes and USE ONLY ON ALUMINUM.
6. Tin surface around area.
7. Brush tinned surface UNDER HEAT, thoroughly filling the open pores around leak.
8. Repair leak. Let aluminum melt solder, NOT the torch.
9. Don't repair for looks. Go for thickness.
10. Perform a leak check.
11. Wash with water.
12. Cover with a good flexible sealant.

HUSSMANN[®]

To obtain warranty information
or other support, contact your Hussmann
representative.

Please include the model and
serial number of the product.