

HUSSMANN CHINO

RGD

UPRIGHT DELI CASE

Installation
& Operation
Manual

REV. 0124



HUSSMANN[®]

RGD
UPRIGHT DELI CASE

1. General Instructions

HUSSMANN®/CHINO

A publication of HUSSMANN® Chino
13770 Ramona Avenue • Chino, California 91710
(909) 628-8942 FAX
(909) 590-4910
(800) 395-9229

www.hussmann.com

This Booklet Contains Information on:

RGD: A narrow depth multi deck air curtain case designed to display pre-packaged Deli products. It can be placed at the end of gondolas or inline with gondola.

Shipping Damage

All equipment should be thoroughly examined for shipping damage before and during unloading.

This equipment has been carefully inspected at our factory and the carrier has assumed responsibility for safe arrival. If damaged, either apparent or concealed, claim must be made to the carrier.

Apparent Loss or Damage

If there is an obvious loss or damage, it must be noted on the freight bill or express receipt and signed by the carrier's agent; otherwise, carrier may refuse claim. The carrier will supply necessary claim forms.

Concealed Loss or Damage

When loss or damage is not apparent until after equipment is uncrated, a claim for concealed damage is made. Make request in writing to carrier for inspection within 15 days, and retain all packaging. The carrier will supply inspection report and required claim forms.

Shortages

Check your shipment for any possible shortages of material. If a shortage should exist and is found to be the responsibility of Hussmann Chino, notify Hussmann Chino. If such a shortage involves the carrier, *notify the carrier immediately*, and request an inspection. Hussmann Chino will acknowledge shortages within ten days from receipt of equipment.

Hussmann Chino Product Control

The serial number and shipping date of all equipment has been recorded in Hussmann's files for warranty and replacement part purposes. All correspondence pertaining to warranty or parts ordering must include the serial number of each piece of equipment involved, in order to provide the customer with the correct parts.

Keep this booklet with the case at all times for future reference.

2. Table of Contents

- 1. General Instructions.....2**
- 2. Table of Contents3**
- 3. Cut and Plan Views4**
- 4. Installation..... 11**
- 5. Plumbing14**
- 6. Refrigeration15**
- 7. Electrical.....22**
- 8. Finishing Touches23**
- 9. User Information.....23**
- 10. Maintenance.....26**
- 11. Controller Data.....28**
- 12. RGD Check List29**
- 13. Electrical Wiring Diagrams30**
- 14. Wiring Diagrams31**
- 15. Troubleshooting Guide67**
- 16. Appendices69**
- 17. Program Parameters72**
- 18. Controller Instructions.....74**

3. Cut and Plan Views

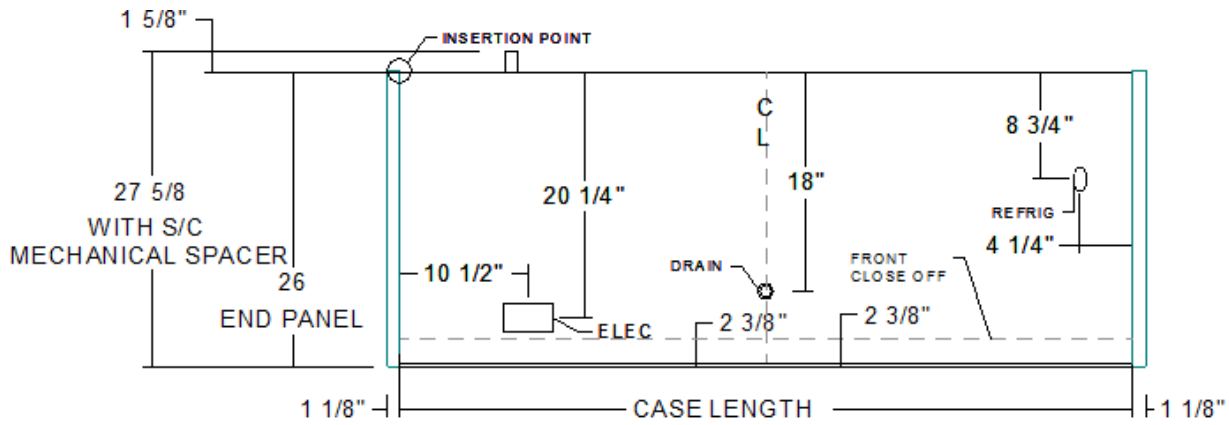

RGD SC 24" PLAN VIEW

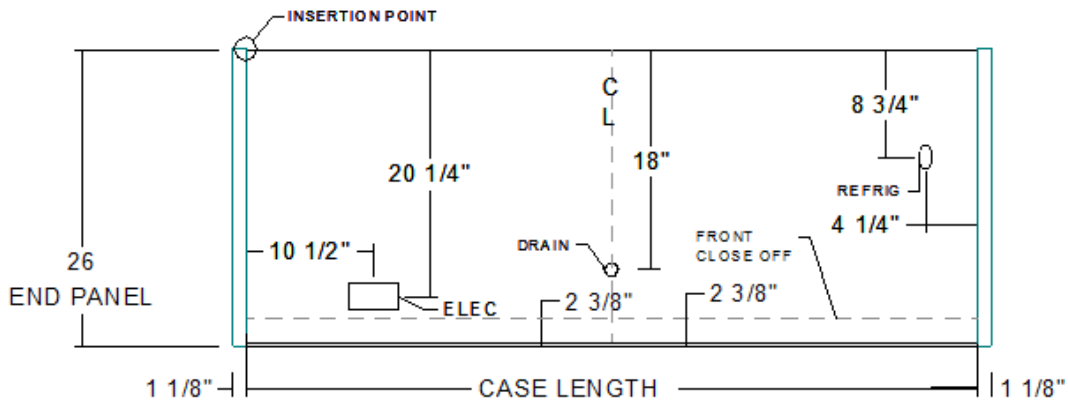

RGD-REM 24" PLAN VIEW

* NOTE END PANEL DEPTH NOT SHOWN SEE CROSS SECTION

Cut and Plan Views (Cont'd)

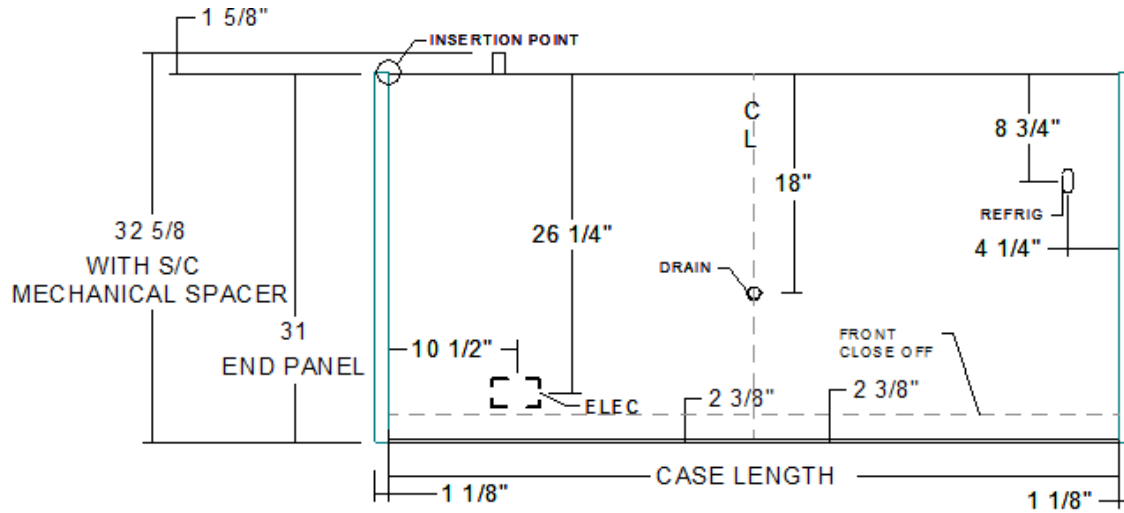

RGD SC 30" PLAN VIEW

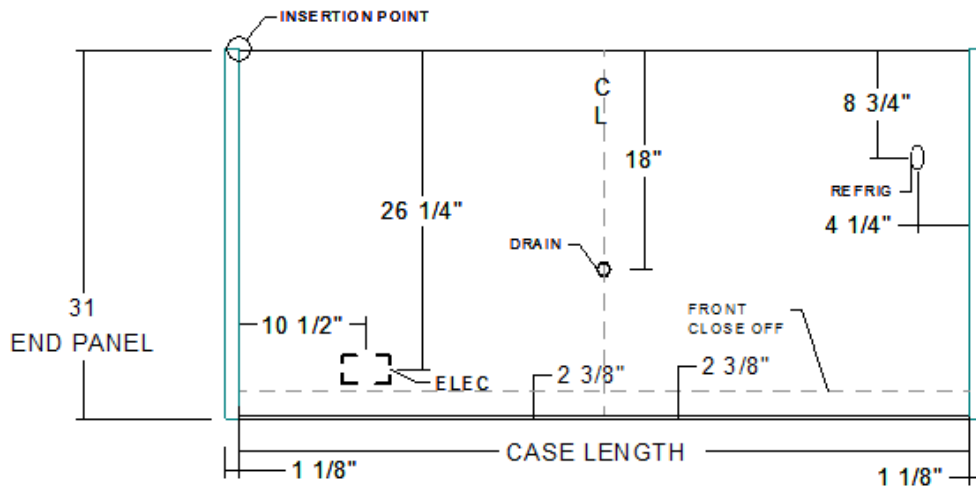

RGD-REM 30" PLAN VIEW

* NOTE END PANEL DEPTH NOT SHOWN SEE CROSS SECTION

Cut and Plan Views (Cont'd)

RGD S/C 24, 30 DEPTH CASE

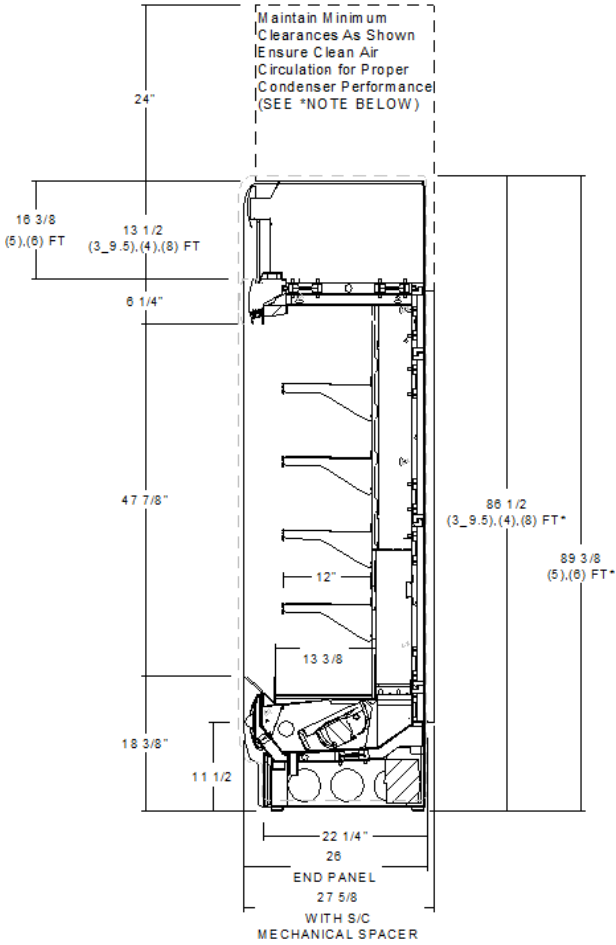

RGD24 72-S/C

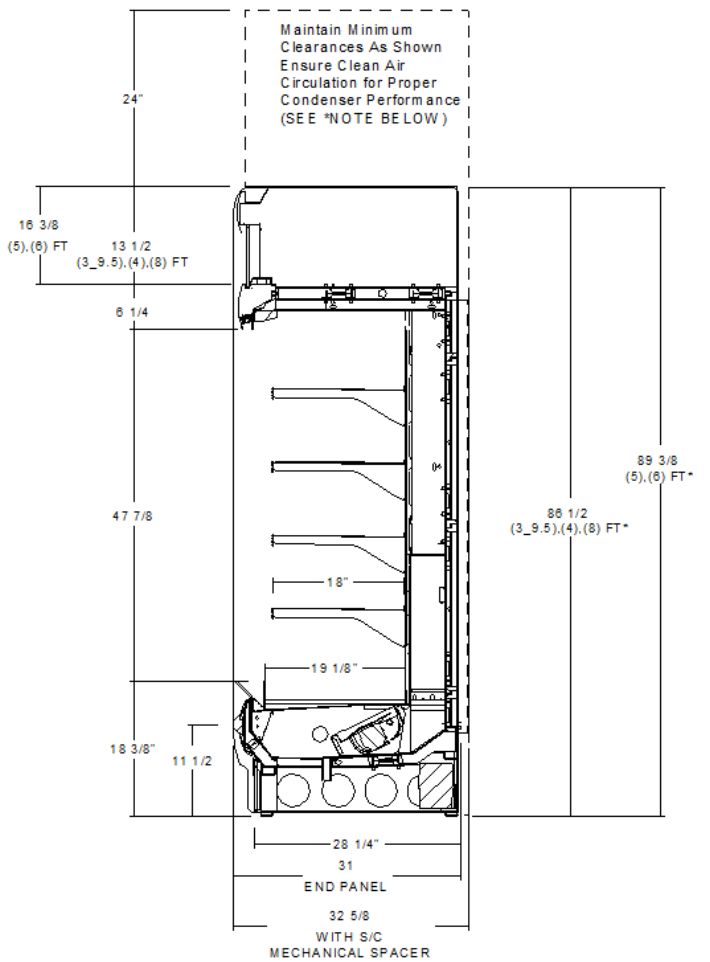

RGD30 72-S/C

Cut and Plan Views (Cont'd)

RGD REM 24 DEPTH CASE

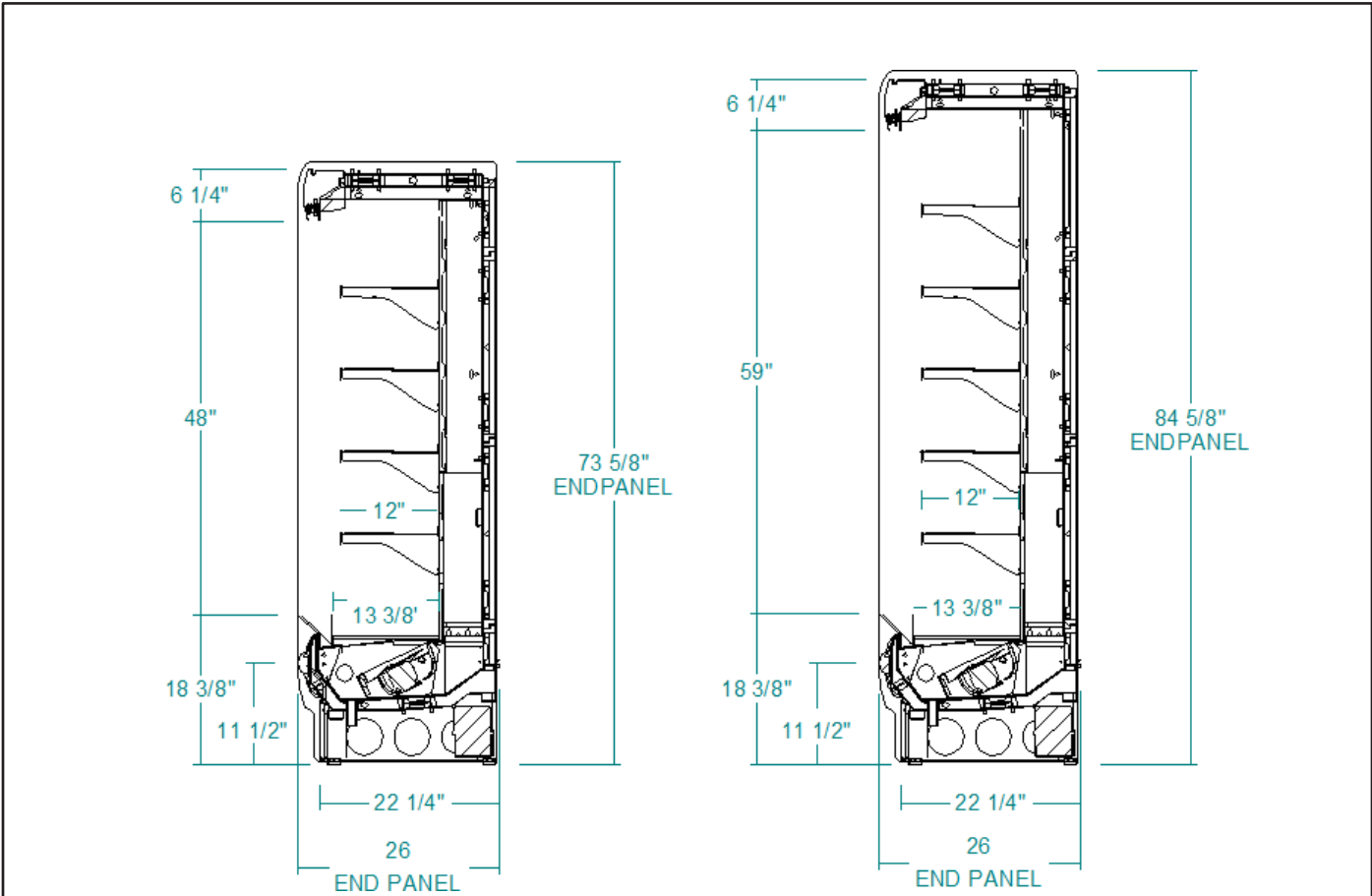

RGD24 72-REM RGD24 83-REM

Cut and Plan Views (Cont'd)

RGD30 REM HEIGHT CASE

RGD30 72-REM

RGD30 83-REM

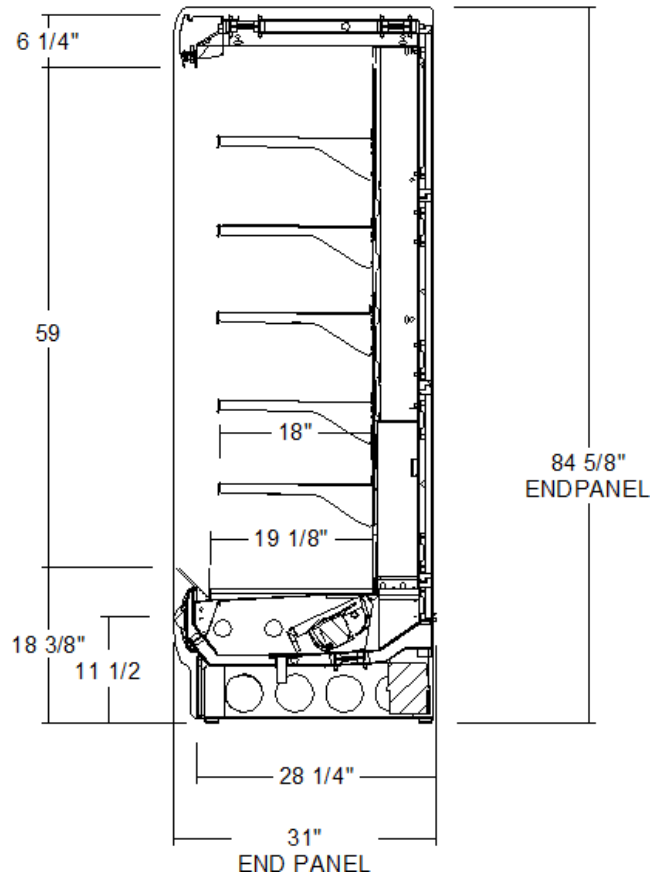
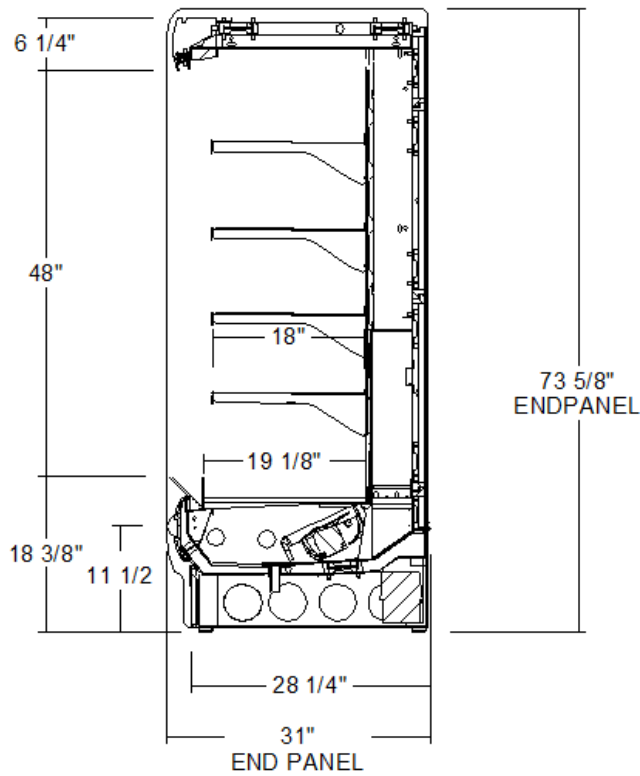

Cut and Plan Views (Cont'd)

RGDC 24 HEIGHT CASE

RGDC24 72-REM

RGDC24 83-REM

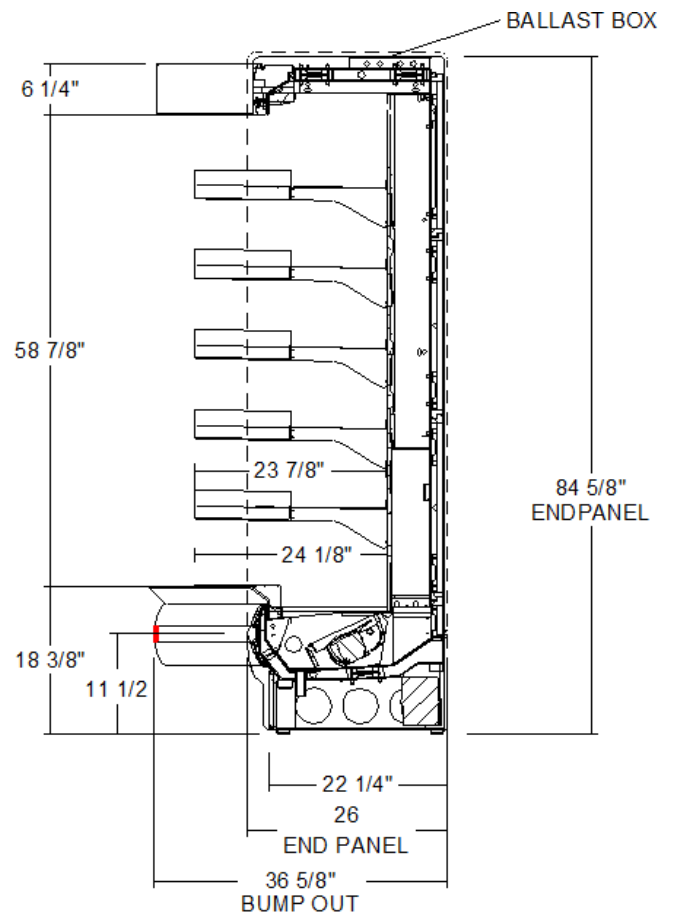
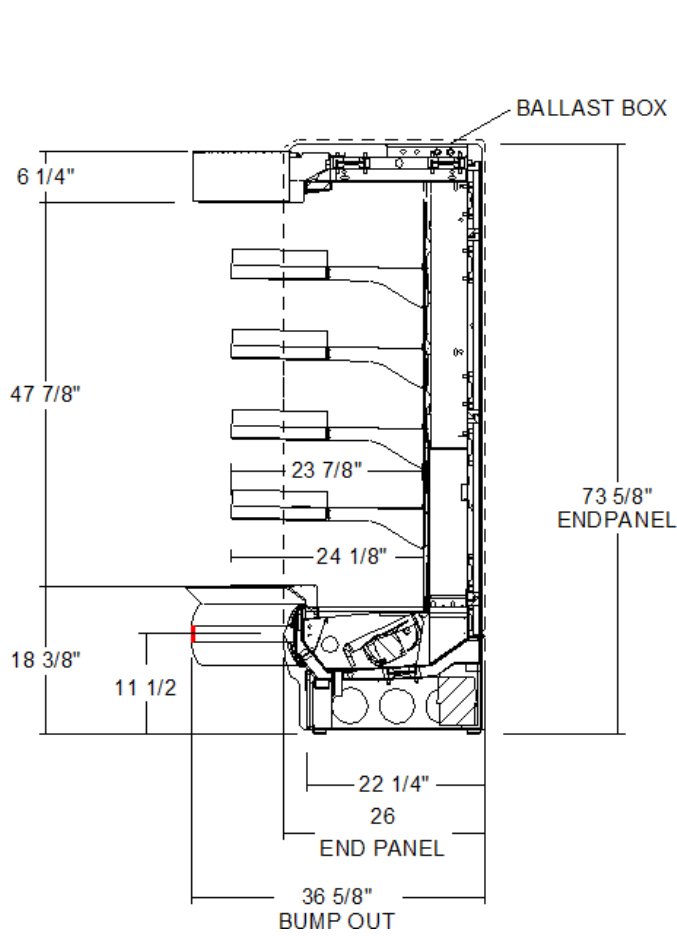

Cut and Plan Views (Cont'd)

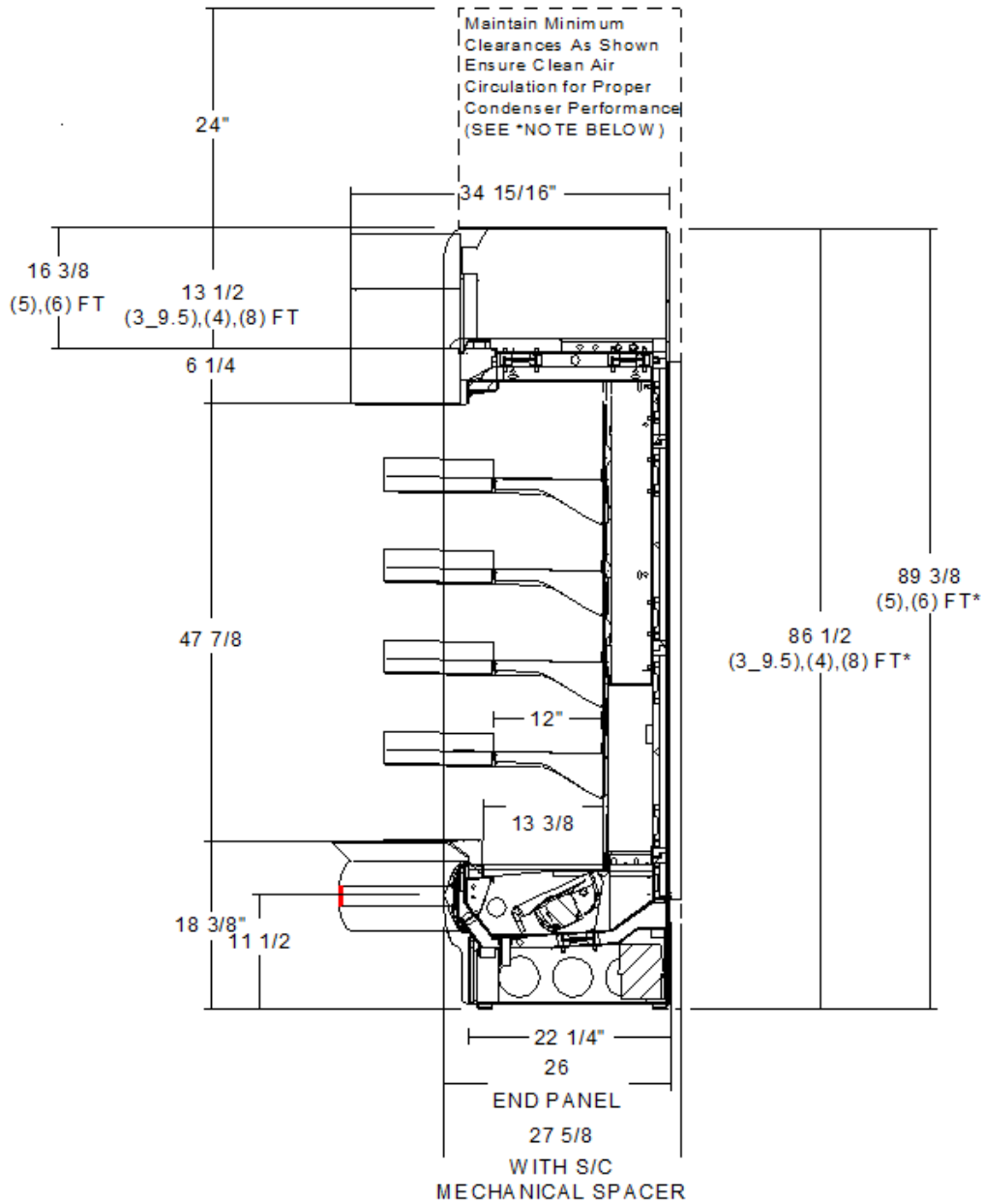

* NOTE

- Maintain Min. Clearances As Shown In (Dotted Area) To Facilitate Air Intake and Discharge
- Clean Air Circulation i.e. No Air Entrapment Above Unit So As To Allow Fresh Air Circulation

RGDC24 72-S\C

4. Installation

Location

The refrigerated merchandisers have been designed for use only in air conditioned stores where temperature and humidity are maintained at or below 75°F and 55% relative humidity. DO NOT allow air conditioning, electric fans, ovens, open doors or windows (etc.) to create air currents around the merchandiser, as this will impair its correct operation.



Uncrating the Stand

Place the fixture as close to its permanent position as possible. Remove the top of the crate. Detach the walls from each other and remove from the skid. Unbolt the case from the skid. The fixture can now be lifted off the crate skid. **Lift only at base of stand!**

Exterior Loading

These models have **not** been structurally designed to support excessive external loading. **Do not walk on their tops;** This could cause serious personal injury and damage to the fixture.

Setting and Joining

The sectional construction of these models enable them to be joined in line to give the effect of one continuous display. A joint trim kit is supplied with each joint.



Leveling

IMPORTANT! IT IS IMPERATIVE THAT CASES BE LEVELED FROM FRONT TO BACK AND SIDE TO SIDE PRIOR TO JOINING. A LEVEL CASE IS NECESSARY TO INSURE PROPER OPERATION, WATER DRAINAGE, GLASS ALIGNMENT, AND OPERATION OF THE HINGES SUPPORTING THE GLASS. LEVELING THE CASE CORRECTLY WILL SOLVE MOST HINGE OPERATION PROBLEMS.

NOTE: A. To avoid removing concrete flooring, begin lineup leveling from the highest point of the store floor.

B. When wedges are involved in a lineup, set them first.

All cases were leveled and joined prior to shipment to insure the closest possible fit when cases are joined in the field. When joining, use a carpenter's level and shim legs accordingly. Case must be raised correctly, under legs where support is best, to prevent damage to case.

1. Check level of floor where cases are to be set. Determine the highest point of the floor; cases will be set off this point.
2. Set first case, and adjust legs over the highest part of the floor so that case is level. Prevent damage - case must be raised under leg or by use of 2x6 or 2x4 leg brace. Remove side and back leg braces after case is set.
3. Set second case as close as possible to the first case, and level case to the first using the instructions in step one.
4. Apply masking tape 1/8" in from end of case on inside and outside rear mullion on both cases to be joined.

Method: RGD Alignment for Line Ups

1. Surface must be clean, dry, and free of debris. Apply Devan Sealant to RGD case sides along joint faces. (See Figure 1)
2. Identify Alignment/Bolting points provide as shown. (See Figure below)
3. Align and adjoin cases in line up configuration.
4. Bolt cases together at Alignment/Bolting points using provided hardware or equivalent hardware. BOLT HEX HEAD 3/8-16 X 3/4" NUT TOP LOCK 3/8-24 ZINC Devan Sealant 255-2
5. Once bolting is complete. Apply silicone to wrapper case joints. (See Figure below)

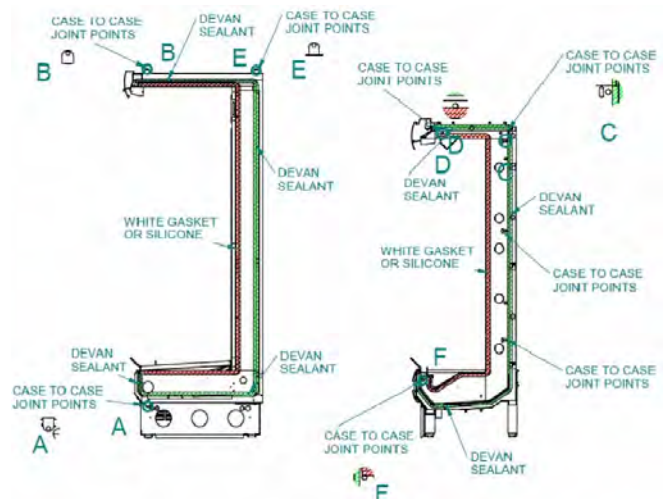

Installation (Cont'd)

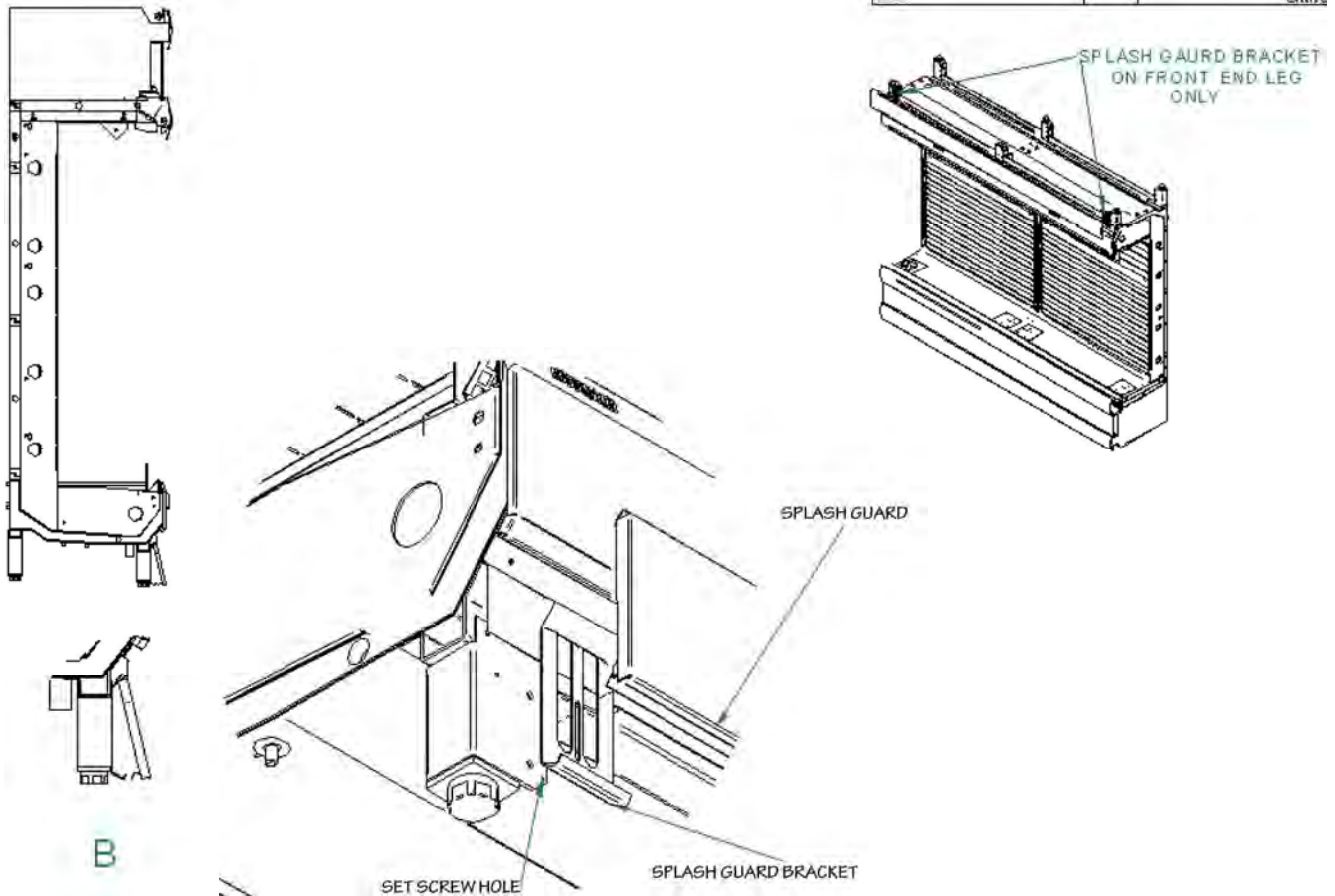

Mount Splashguard and Bracket

- Set bracket, align $\frac{1}{4}$ slot to set screw hole
- Screw bracket, loosely to a low to drop to floor
- Snap in splashguard by setting the top in first
- And push in firmly to snap in.
- See drawing above



SPLASH GUARD
MOUNT HOLE
LOCATION

Installation (Cont'd)



Bumper Installation Instructions

Step 1: Starting on one end: while inserting the bumper, push it up against the end to prevent the bumper from shrinking after installation (when it gets cold).

Step 2: As you insert the bumper into the channel with one hand, pull the bumper toward you with the other to open the inside lips. Slowly apply pressure by rolling the bumper into the track.

5. Plumbing

Waste Outlet and P-TRAP

The waste outlet is located in the center, 8" from the front of the case.

P-traps must be installed at the base of all refrigerated cases. The 1 ½" P-TRAPS and threaded adapters must be installed to prevent air leakage and insect entrance into the fixture.

Installing Condensate Drain

Poorly or improperly installed condensate drains can seriously interfere with the operation of this refrigerator, and result in costly maintenance and product losses. Please follow the recommendations listed below when installing condensate drains to insure a proper installation:

1. Never use pipe for condensate drains smaller than the nominal diameter of the pipe or P-TRAP supplied with the case.
2. When connecting condensate drains, the P-TRAP must be used as part of the condensate drain to prevent air leakage or insect entrance. Store plumbing system floor drains should be at least 14" off the center of the case to allow use of the P-TRAP pipe section. Never use two water seals in series in any one line. Double P-TRAPS in series will cause a lock and prevent draining.
3. Always provide as much down hill slope ("fall") as possible; 1/8" per foot is the preferred minimum. PVC pipe, when used, must be supported to maintain the 1/8" pitch and to prevent warping.
4. Avoid long runs of condensate drains. Long runs make it impossible to provide the "fall" necessary for good drainage.
5. Provide a suitable air break between the flood rim of the floor drain and outlet of condensate drain. 1" is ideal.
6. Prevent condensate drains from freezing:
 - a. Do not install condensate drains in contact with non-insulated suction lines. Suction lines should be insulated with a non absorbent insulation material such as Armstrong's Armaflex.
 - b. Where condensate drains are located in dead air spaces (between refrigerators or between a refrigerator and a wall), provide means to prevent freezing. The water seal should be insulated to prevent condensation.

RGD (Self Contained)

The waste outlet and P-TRAP are the same as the remote except the case condensate drains to a pump assembly mounted to the bottom rear of the case. Condensate is pumped to the top of the water evap pan assembly. Hot air from the condenser is forced through the water evap assembly, evaporating the water. Any overflow from the water evap assembly is directed back to the pump assembly. **It is critical that the case be level to keep the water evap assembly from overflowing!!** The metal cover over the top of the condensing unit must be in place to force the hot condenser air through the water evap assembly.

The condensate pump can be accessed through the front of the closeoff panel.

WARNING!
Do NOT apply thread sealer to ABS P-Trap.



6. Refrigeration

Refrigerant Type

The standard refrigerant will be R-404A unless otherwise specified on the customer order. Check the serial plate on the case for information.

Piping

The refrigerant line outlets are located under the deck pans. Insulate suction lines to prevent condensation drippage.

Access Panels

All electrical and drain access panels are clearly labeled on the deck of the Deli/Beverage case. The access for condensing units (in the self contained units) is located on the side of the stand, at the end. Ends of stand are fitted for removal, if condensing unit has to be taken out.

Refrigeration Lines

<u>Liquid</u>	<u>Suction</u>
3/8" O.D.	5/8" O.D.

NOTE: The standard coil is piped at 5/8" (suction); however, the store tie-in may vary depending on the number of coils and the draw the case has. Depending on the case setup, the connecting point in the store may be 5/8", 7/8", or 1 1/8". Refer to the particular case you are hooking up.

Refrigerant lines should be sized as shown on the refrigeration legend furnished by the store.

Oil traps must be installed at the base of all suction line vertical risers on refrigerated cases.

Pressure drop can rob the system of capacity. To keep the pressure drop to a minimum, keep refrigerant line run as short as possible, using the minimum number of elbows. Where elbows are required, use long radius elbows only.

Control Settings

See RGD technical data sheet for the appropriate settings for your merchandiser. Maintain these parameters to achieve near constant product temperatures. Product temperature should be measured first thing in the morning, after having been refrigerated overnight. For all multiplexing, defrost should be time terminated. Defrost times should be as follows: OFF CYCLE - Six times daily for 25 minutes. The number of defrosts per day should never change. The duration of the defrost cycle may be adjusted to meet conditions present at your location.

Access to TX Valves and Drain Lines

Mechanical - Remove product from end of case. Remove product racks. Remove refrigeration and drain access panels (labeled). TX valve (mechanical only) and drain are located under each access panel at end of the case.

Electronic - The Electronic Expansion valve master and

slave cylinder(s) are located within the electrical access panel(s).

Electronic Expansion Valve (Optional)

A wide variety of electronic expansion valves and case controllers can be utilized. Please refer to EEV and controller manufacturers information sheet. Sensors for electronic expansion valves will be installed on the coil outlet, and in the discharge air. (Some supermarkets require a 3rd sensor in the return air). Case controllers will be located in the electrical raceway or under the case.

Thermostatic Expansion Valve Location

An Alco balanced port expansion valve model is furnished as standard equipment, unless otherwise specified by customer. There is one expansion valve located on the left side of each evaporation coil under the bottom deck pans.

Expansion Valve Adjustment

Expansion valves must be adjusted to fully feed the evaporator. Before attempting any adjustments, make sure the evaporator is either clear or very lightly covered with frost, and that the fixture is within 10°F of its expected operating temperature.

Measuring the Operating Superheat

1. Determine the suction pressure with an accurate pressure gauge at the evaporator outlet.
2. From a refrigerant pressure temperature chart, determine the saturation temperature at the observed suction pressure.
3. Measure the temperature of the suction gas at the thermostatic remote bulb location.
4. Subtract the saturation temperature obtained in step No. 2 from the temperature measured in step No. 3.
5. The difference is superheat.
6. Set the superheat for 5°F - 7°F.

Condenser Ventilation

Be sure to supply adequate ventilation for the condenser in Self Contained units. Allow 212 square inches for units up to 1 h.p., and 260 for condenser units up to 1 1/2-1 3/4 h.p.

T-STAT Location

The T-STATS are located within the electrical raceway. The raceway's location will remain under the front fascia of the case. In all cases, the T-STAT is located on the same side of the case. If you are looking at the case from the front, it is the right-hand side.

Refrigeration cont'd

Self Contained

On self contained cases the unit is completely charged and tested to the proper temperature. Switch on the compressor. Set the timeclock to the proper time of day by turning the dial in the direction of the arrow until the pointer and current time of day align.

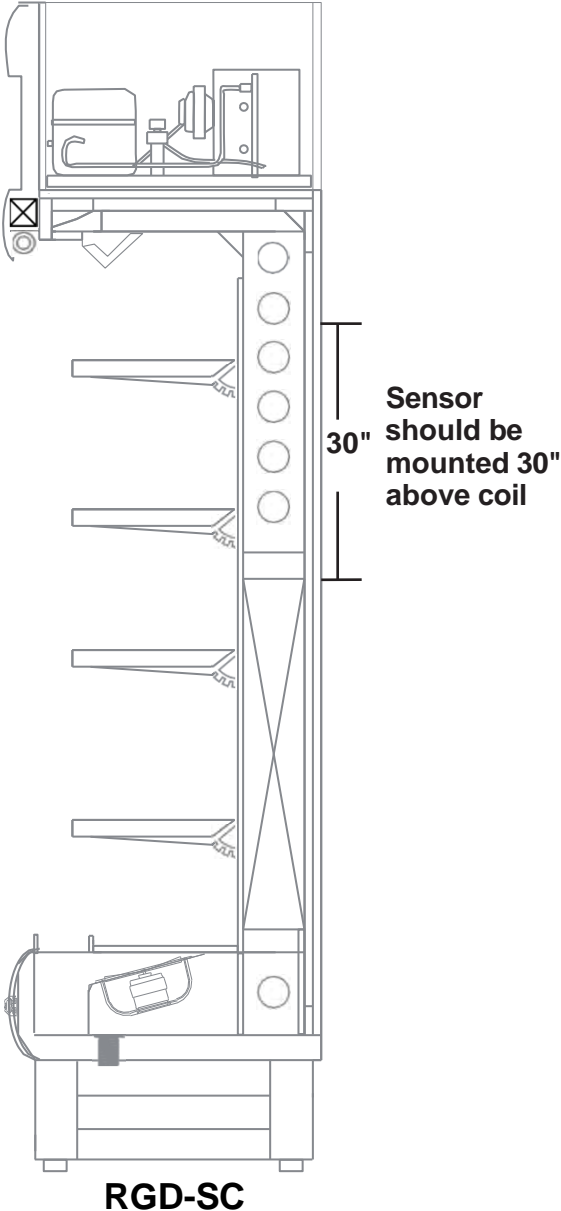



SELF-SERVICE DELI TYPE I
HUSSMANN - RGD - 24 - 72 SELF CONTAINED (CHINO)

REVISION DATE

17
07/09/20



Hussmann refrigerated merchandisers configured for sale for use in the United States meet or surpass the requirements of the DOE 2017 energy efficiency standards.

RGD 24, 30 Remote and Self Contained plan view

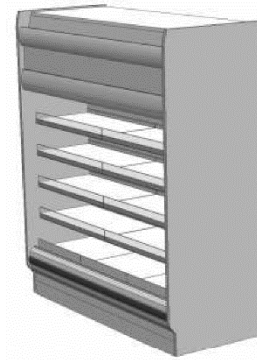
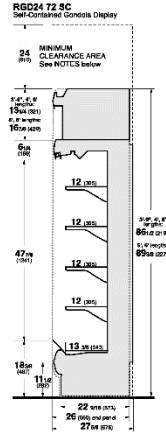
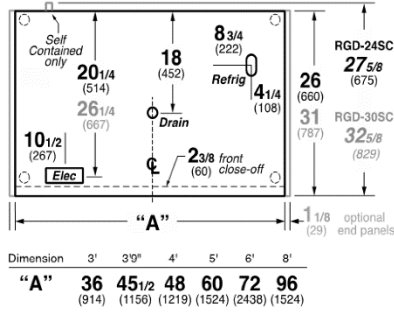

REFRIGERATION DATA:

CASE LENGTHS	CASE USAGE	CONVENTIONAL CAPACITY ** (BTU/HR/FT)	AVERAGE DISCHARGE AIR* (°F) (SEE SETPOINTS BELOW)	VELOCITY (FT/MIN)
3', 3'9", 4', 5', 6', 8'	SS DELI	1900	28-30	150-200

*FRONT DISCHARGE AIR MEASURED INSIDE AIR CURTAIN HONEYCOMB

**REFRIGERATION NOTES:

- CAPACITY FOR REFERENCE ONLY.
- ALL CASES EQUIPPED WITH NIGHT CURTAINS.
- USE DEW POINT FOR HIGH GLIDE REFRIGERANTS. CARE SHOULD BE TAKEN TO USE THE DEW POINT IN P/T TABLES FOR MEASURING AND ADJUSTING SUPERHEAT. ADJUST EVAPORATOR PRESSURE AS NEEDED TO MAINTAIN THE DISCHARGE AIR TEMPERATURE SHOWN.
- RATING CONDITION IS NSF TYPE I, 75°F/55% RH

REFRIGERATION DATA CONTINUED:

CONTROLLER / AIR SENSOR SETTINGS			DEFROST TYPE	FAILSAFE TIME (MIN)	DEFROST FREQUENCY (#/DAY)	TERM. TEMP (°F) AIR	DRIP TIME (MIN)	DEFROST WATER (LBS/DAY/FT)
USAGE	SET POINT (°F)	DIFFERENTIAL (°F)						
DELI	24	8	OFF TIME	25	4	48	NA	4.2

END PANEL WIDTH KEY		
# OF END PNLS	END PNL WIDTH (IN.)	TOTAL ADDED LENGTH (IN.)
1	1.125	1.125
2	1.125	2.25

ELECTRICAL DATA:

STANDARD FANS, HEATERS, LED LIGHTS (115 VOLT)

CASE LENGTH	EVAPORATOR FANS					CANOPY LIGHTS LED		OPTIONAL LED SHELF LIGHTS		MAX. LED LOAD (W/ ALL OPTIONS)		ANTI-SWEAT HEATERS		CONVENIENCE OUTLETS (OPTIONAL)		
	# OF EVAP FANS	BLADE DIA. (IN.)	BLADE PITCH (°)	AMPS	WATTS	AMPS	WATTS	AMPS	WATTS	AMPS	WATTS	AMPS	WATTS	# OUTLETS	VOLTS	AMPS
3'	1	8	25	0.3	8	0.17	19	0.34	39	0.50	58	N/A	N/A	N/A	N/A	N/A
3'9"	1	8	25	0.3	8	0.17	19	0.34	39	0.50	58	N/A	N/A	N/A	N/A	N/A
4'	1	8	25	0.3	8	0.23	27	0.45	51	0.68	78	N/A	N/A	N/A	N/A	N/A
5'	2	8	37	0.6	16	0.30	34	0.56	65	0.86	99	N/A	N/A	N/A	N/A	N/A
6'	2	8	25	0.6	16	0.34	39	0.67	77	1.01	116	N/A	N/A	N/A	N/A	N/A
8'	2	8	25	0.6	16	0.47	54	0.90	103	1.36	157	N/A	N/A	N/A	N/A	N/A

CONDENSING UNIT AND EVAPORATIVE PANS

CASE LENGTH	NOM. HP	CONDENSING UNIT			EVAPORATIVE PAN			PLUG TYPE ***	EST. REFG. CHR.G. (LBS)	
		REFRIG.	HZ/PH	VOLTS	RLA	VOLTS	AMPS			WATTS
3'	3/4	R-404A	60 / 1	208/240	6.8	240	6.3	1500	L14-30P	4.6
3'9"	1		60 / 1	208/240	7.7	240	6.3	1500	L14-30P	6.0
4'	1		60 / 1	208/240	7.7	240	6.3	1500	L14-30P	6.0
5'	1 1/4		60 / 1	208/240	9.3	240	6.3	1500	L14-30P	6.6
6'	1 3/4		60 / 1	208/240	12.6	240	6.3	1500	L14-30P	10.3
8' ****	1		60 / 1	208/240	7.7	240	12.5	3000	CS-6365-C 50A	12.0
3'	3/4	R-448A	60 / 1	208/240	9.0	240	6.3	1500	L14-30P	4.6
3'9"	1		60 / 1	208/240	9.3	240	6.3	1500	L14-30P	6.0
4'	1 1/4		60 / 1	208/240	10.0	240	6.3	1500	L14-30P	6.0
5'	1 3/4		60 / 1	208/240	12.6	240	6.3	1500	L14-30P	6.6
6'	1 3/4		60 / 1	208/240	12.6	240	6.3	1500	L14-30P	10.3
8' ****	1 1/4		60 / 1	208/240	10.0	240	12.5	3000	CS-6365-C 50A	12.0

***PLUG TYPE INCLUDES FANS, LIGHTS, COND. UNIT AND EVAP PAN

****2 CONDENSING UNITS

OPTIONAL HIGH OUTPUT LED LIGHTS (115 VOLT)

CASE LENGTH	CANOPY LIGHTS H.O. LED		OPTIONAL SHELF		MAX. H.O. LED LOAD	
	AMPS	WATTS	AMPS	WATTS	AMPS	WATTS
3'	0.21	24	0.63	73	0.84	96
3'9"	0.21	24	0.63	73	0.84	96
4'	0.28	32	0.75	86	1.03	118
5'	N/A	N/A	N/A	N/A	N/A	N/A
6'	0.41	47	1.26	145	1.67	193
8'	0.56	64	1.50	173	2.06	237



SELF-SERVICE DELI
HUSSMANN - RGD - 24 / 30 - 72 REMOTE (CHINO)

REVISION DATE 02/24/17



Hussmann refrigerated merchandisers configured for sale for use in the United States meet or surpass the requirements of the DOE 2017 energy efficiency standards.



RGD 24, 30 Remote and Self Contained plan view

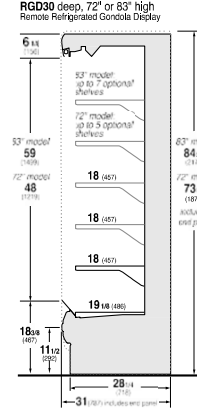
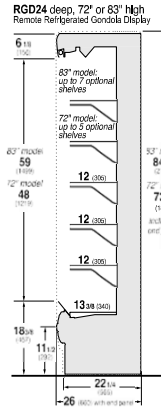
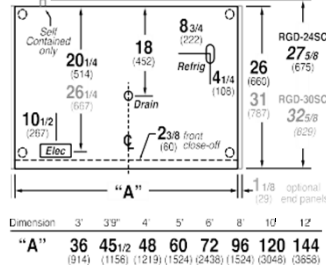

REFRIGERATION DATA:

CASE LENGTHS	CASE USAGE	CAPACITY *** (BTU/HR/FT)		TEMPERATURE (°F)			VELOCITY (FT/MIN)
		RATING CONDITION		EVAPORATOR		DISCHARGE AIR ** (°F)	
		NSF 7	AHRI 1200	NSF 7	AHRI 1200	NSF 7	
3'9", 4', 5', 6', 8', 10', 12'	SS DELI	1450	1150	20	24	28-30	150-200

CASE LENGTHS	EST. REFRIG. CHRG. (R404A) (LBS)	20°F GLYCOL 6" RISE	
		GPM	PSI
3'9"	0.7	2.0	2.1
4'	1.0	2.1	2.8
5'	1.2	2.6	4.3
6'	1.4	3.1	2.5
8'	2.0	4.1	4.0
10'	2.5	5.0	5.7
12'	2.9	5.9	5.2

****FRONT DISCHARGE AIR MEASURED INSIDE AIR CURTAIN HONEYCOMB**

*****REFRIGERATION NOTES:**

- 1) BTU'S INCLUDE 1 ROW CANOPY LED LIGHTS AND NO SHELF LIGHTS.
- 2) ADD 10 BTU'S PER FOOT/PER SHELF ROW FOR OPTIONAL LED SHELF LIGHTS.
- 3) ADD 140 BTU/HR/FT TO AHRI TEST FOR 30" DEPTH OPTION.
- 4) ALL CASES EQUIPPED WITH NIGHT CURTAINS.
- 5) FOR AHRI, NIGHT CURTAINS ARE PULLED DOWN FOR 6 OF 24 HOURS AND ALL LIGHTS ARE TURNED OFF PER AHRI 1200 TEST PROCEDURE.
- 6) FOR NSF 7, THE LOAD LISTED IS WITHOUT THE NIGHT CURTAINS PULLED DOWN.
- 7) AHRI 1200 RATING POINT FOR ENERGY CONSUMPTION COMPARISON ONLY.
- 8) USE DEW POINT FOR HIGH GLIDE REFRIGERANTS. CARE SHOULD BE TAKEN TO USE THE DEW POINT IN P/T TABLES FOR MEASURING AND ADJUSTING SUPERHEAT. ADJUST EVAPORATOR PRESSURE AS NEEDED TO MAINTAIN THE DISCHARGE AIR TEMPERATURE SHOWN.
- 9) RATING CONDITION IS NSF TYPE I, 75°F/55% RH.

REFRIGERATION DATA CONTINUED:

ELEC. THERMOSTAT / AIR SENSOR SETTINGS			DEFROST TYPE	TIME (MIN)	DEFROST FREQUENCY (#/DAY)	TERM. TEMP (°F) COIL ONLY	DRIP TIME	DEFROST WATER (LBS/DAY/FT)
USAGE	CUT IN (°F)	CUT OUT (°F)						
SS DELI	30	27	OFF TIME	25	6	48	N/A	7

END PANEL WIDTH KEY		
# OF END PNLS	END PNL WIDTH (IN.)	TOTAL ADDED LENGTH (IN.)
1	1.125	1.125
2	1.125	2.25

ELECTRICAL DATA:

STANDARD FANS, HEATERS, LED LIGHTS (115 VOLT)

CASE LENGTH	EVAPORATOR FANS				CANOPY LIGHTS LED		OPTIONAL LED SHELF LIGHTS		MAX. LED LOAD (W/ ALL OPTIONS)		ANTI-SWEAT HEATERS (ON FAN CIRCUIT)		CONVENIENCE OUTLETS (OPTIONAL)			
	# OF EVAP FANS	BLADE DIA. (IN.)	BLADE PITCH (°)	AMPS	WATTS	AMPS	WATTS	AMPS	WATTS	AMPS	WATTS	AMPS	WATTS	# OUTLETS	VOLTS	AMPS
3'9"	1	8	25	0.3	8	0.17	19	0.34	39	0.50	58	N/A	N/A	N/A	N/A	N/A
4'	1	8	25	0.3	8	0.23	27	0.45	51	0.68	78	N/A	N/A	N/A	N/A	N/A
5'	2	8	37	0.6	16	0.30	34	0.56	65	0.86	99	N/A	N/A	N/A	N/A	N/A
6'	2	8	25	0.6	16	0.34	39	0.67	77	1.01	116	N/A	N/A	N/A	N/A	N/A
8'	2	8	25	0.6	16	0.47	54	0.90	103	1.36	157	N/A	N/A	N/A	N/A	N/A
10'	4	8	37	1.2	32	0.59	68	1.13	130	1.72	198	N/A	N/A	N/A	N/A	N/A
12'	3	8	25	0.9	24	0.70	81	1.34	154	2.04	235	N/A	N/A	N/A	N/A	N/A

OPTIONAL HIGH OUTPUT LED LIGHTS (115 VOLT)

CASE LENGTH	CANOPY LIGHTS H.O. LED		OPTIONAL SHELF		MAX. H.O. LED LOAD	
	AMPS	WATTS	AMPS	WATTS	AMPS	WATTS
3'9"	N/A	N/A	N/A	N/A	N/A	N/A
4'	N/A	N/A	N/A	N/A	N/A	N/A
5'	N/A	N/A	N/A	N/A	N/A	N/A
6'	N/A	N/A	N/A	N/A	N/A	N/A
8'	N/A	N/A	N/A	N/A	N/A	N/A
10'	N/A	N/A	N/A	N/A	N/A	N/A
12'	N/A	N/A	N/A	N/A	N/A	N/A



SELF-SERVICE DELI
HUSSMANN - RGD - 24 / 30 - 83 (CHINO)

DOE 2017 Energy Efficiency Compliant
 Hussmann refrigerated merchandisers configured for sale for use in the United States meet or surpass the requirements of the DOE 2017 energy efficiency standards.

REVISION DATE 01/26/17

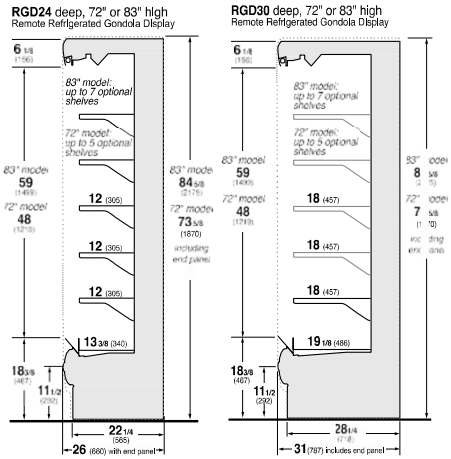
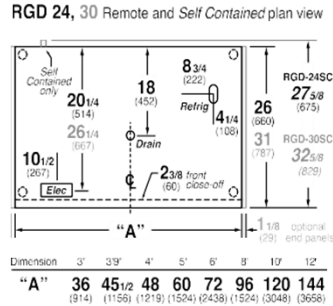

REFRIGERATION DATA:

CASE LENGTHS	CASE USAGE	CAPACITY *** (BTU/HR/FT)		TEMPERATURE (°F)			VELOCITY (FT/MIN)
		RATING CONDITION		EVAPORATOR		DISCHARGE AIR ** (°F)	
		NSF 7	AHRI 1200	NSF 7	AHRI 1200	NSF 7	
3'9", 4'5", 6'8", 10', 12'	SS DELI	1550	1450	20	26	30-32	160-250

CASE LENGTHS	EST. REFG. CHR.G. (R404A) (LBS)	20°F GLYCOL 6° RISE	
		GPM	PSI
3'9"	0.7	2.1	2.2
4'	1.0	2.2	2.9
5'	1.2	2.7	4.4
6'	1.4	3.2	2.6
8'	2.0	4.2	4.1
10'	2.5	5.2	5.9
12'	2.9	6.1	5.4

**FRONT DISCHARGE AIR MEASURED INSIDE AIR CURTAIN HONEYCOMB

***REFRIGERATION NOTES:

- 1) BTU'S INCLUDE 1 ROW CANOPY LED LIGHTS AND NO SHELF LIGHTS
- 2) ADD 10 BTU'S PER FOOT/PER SHELF ROW FOR OPTIONAL LED SHELF LIGHTS
- 3) ADD 140 BTU/HR/FT TO AHRI TEST FOR 30" DEPTH OPTION
- 4) ALL CASES EQUIPPED WITH NIGHT CURTAINS
- 5) FOR AHRI TEST, NIGHT CURTAINS ARE PULLED DOWN FOR 6 HOURS AND ALL LIGHTS ARE TURNED OFF PER AHRI 1200 TEST PROC
- 6) FOR NSF 7, THE LOAD LISTED IS WITHOUT THE NIGHT CURTAINS PULLED DOWN,
- 7) AHRI 1200 RATING POINT FOR ENERGY CONSUMPTION COMPARISON ONLY
- 8) USE DEW POINT FOR HIGH GLIDE REFRIGERANTS. CARE SHOULD BE TAKEN TO USE THE DEW POINT IN P/T TABLES FOR MEASURING AND ADJUSTING SUPERHEAT. ADJUST EVAPORATOR PRESSURE AS NEEDED TO MAINTAIN THE DISCHARGE AIR TEMPERATURE SHOWN.
- 9) RATING CONDITION IS NSF TYPE I, 75°F/55% RH

REFRIGERATION DATA CONTINUED:

ELEC. THERMOSTAT / AIR SENSOR SETTINGS			DEFROST TYPE	TIME (MIN)	DEFROST FREQUENCY (#/DAY)	TERM. TEMP (°F) COIL ONLY	DRIP TIME	DEFROST WATER (LBS/DAY/FT)
USAGE	CUT IN (°F)	CUT OUT (°F)						
SS DELI	31	28	OFF TIME	25	6	52	N/A	7.0

END PANEL WIDTH KEY		
# OF END PNLS	END PNL WIDTH (IN.)	TOTAL ADDED LENGTH (IN.)
1	1.125	1.125
2	1.125	2.25

ELECTRICAL DATA:

STANDARD FANS, HEATERS, LED LIGHTS (115 VOLT)

CASE LENGTH	EVAPORATOR FANS					CANOPY LIGHTS LED		OPTIONAL LED SHELF LIGHTS		MAX. LED LOAD (W/ ALL OPTIONS)		ANTI-SWEAT HEATERS (ON FAN CIRCUIT)		CONVENIENCE OUTLETS (OPTIONAL)		
	# OF EVAP FANS	BLADE DIA. (IN.)	BLADE PITCH (°)	AMPS	WATTS	AMPS	WATTS	AMPS	WATTS	AMPS	WATTS	AMPS	WATTS	# OUTLETS	VOLTS	AMPS
3'9"	1	8	37	0.3	8	0.2	19	0.5	54	0.6	73	N/A	N/A	N/A	N/A	N/A
4'	1	8	37	0.3	8	0.2	27	0.6	72	0.9	99	N/A	N/A	N/A	N/A	N/A
5'	2	8	37	0.6	16	0.3	34	0.8	91	1.1	125	N/A	N/A	N/A	N/A	N/A
6'	2	8	37	0.6	16	0.3	39	0.9	108	1.3	147	N/A	N/A	N/A	N/A	N/A
8'	2	8	37	0.6	16	0.5	54	1.3	144	1.7	198	N/A	N/A	N/A	N/A	N/A
10'	4	8	37	1.2	32	0.6	68	1.6	182	2.2	250	N/A	N/A	N/A	N/A	N/A
12'	3	8	37	0.9	24	0.7	81	1.9	216	2.6	297	N/A	N/A	N/A	N/A	N/A

OPTIONAL HIGH OUTPUT LED LIGHTS (115 VOLT)

CASE LENGTH	CANOPY LIGHTS H.O. LED		OPTIONAL SHELF		MAX. H.O. LED LOAD	
	AMPS	WATTS	AMPS	WATTS	AMPS	WATTS
3'9"	N/A	N/A	N/A	N/A	N/A	N/A
4'	N/A	N/A	N/A	N/A	N/A	N/A
5'	N/A	N/A	N/A	N/A	N/A	N/A
6'	N/A	N/A	N/A	N/A	N/A	N/A
8'	N/A	N/A	N/A	N/A	N/A	N/A
10'	N/A	N/A	N/A	N/A	N/A	N/A
12'	N/A	N/A	N/A	N/A	N/A	N/A



SELF-SERVICE DELI
HUSSMANN - RGD-24-83-X-R-DR (CHINO)

REVISION DATE 07/03/19

DOE 2017 Energy Efficiency Compliant Hussmann refrigerated merchandisers configured for sale for use in the United States meet or surpass the requirements of the DOE 2017 energy efficiency standards.

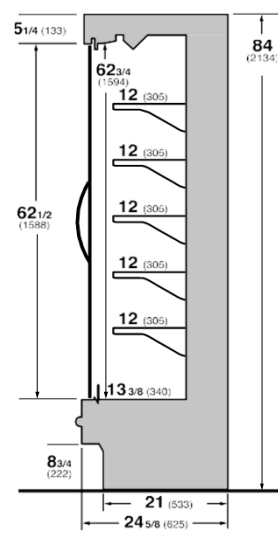
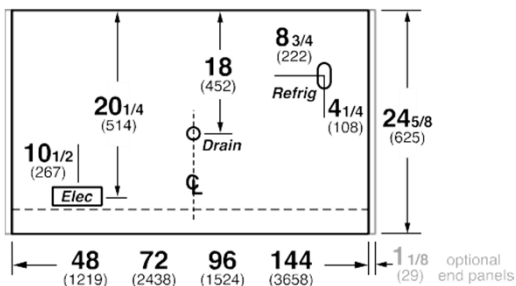

REFRIGERATION DATA:

CASE LENGTHS	CASE USAGE	CAPACITY *** (BTU/HR/FT)		TEMPERATURE (°F)			VELOCITY (FT/MIN)
		RATING CONDITION		EVAPORATOR		DISCHARGE AIR ** (°F)	
		NSF 7	AHRI 1200	NSF 7	AHRI 1200	NSF 7	NSF 7
4', 6', 8', 12'	DELI /CHEESE	330	300	26	28	32-34	250

CASE LENGTHS	EST. REFG. CHR.G. (R404A) (LBS)	20°F GLYCOL 6° RISE	
		GPM	PSI
4'	1.5	0.5	0.3
6'	1.9	0.7	0.3
8'	2.5	0.9	0.6
12'	2.4	1.3	0.9

**FRONT DISCHARGE AIR MEASURED INSIDE AIR CURTAIN HONEYCOMB

***REFRIGERATION NOTES:

- 1) BTU'S INCLUDE 1 ROW CANOPY LED LIGHTS, TWO END MULLION LIGHTS, AND NO SHELF LIGHTS
- 2) AHRI 1200 RATING POINT FOR ENERGY CONSUMPTION COMPARISON ONLY
- 3) USE DEW POINT FOR HIGH GLIDE REFRIGERANTS. CARE SHOULD BE TAKEN TO USE THE DEW POINT IN P/T TABLES FOR MEASURING AND ADJUSTING SUPERHEAT. ADJUST EVAPORATOR PRESSURE AS NEEDED TO MAINTAIN THE DISCHARGE AIR TEMPERATURE SHOWN.
- 5) RATING CONDITION IS NSF TYPE I, 75°F/55% RH

REFRIGERATION DATA CONTINUED:

ELEC. THERMOSTAT / AIR SENSOR SETTINGS			DEFROST TYPE	TIME (MIN)	DEFROST FREQUENCY (#/DAY)	TERM. TEMP (°F) COIL ONLY	DRIP TIME	DEFROST WATER (LBS/DAY/FT)
USAGE	CUT IN (°F)	CUT OUT						
DELI / CHEESE	34	30	OFF TIME	55	1	48	N/A	1

END PANEL WIDTH KEY		
# OF END PNLS	END PNL WIDTH (IN.)	TOTAL ADDED LENGTH (IN.)
1	1.125	1.125
2	1.125	2.25

ELECTRICAL DATA:

STANDARD FANS, HEATERS, LED LIGHTS (115 VOLT)

CASE LENGTH	EVAPORATOR FANS				CANOPY LIGHTS LED		MULLION LIGHTS LED		MAX. LED LOAD		ANTI-SWEAT HEATERS		CONVENIENCE OUTLETS (OPTIONAL)			
	# OF EVAP FANS	BLADE DIA. (IN.)	BLADE PITCH (°)	AMPS	WATTS	AMPS	WATTS	AMPS	WATTS	AMPS	WATTS	AMPS	WATTS	# OUTLETS	VOLTS	AMPS
4'	1	8.25	37°	0.3	8	0.2	27	0.2	21	0.4	48	N/A	N/A	N/A	N/A	N/A
6'	2	8.25	37°	0.6	16	0.3	39	0.3	35	0.6	74	N/A	N/A	N/A	N/A	N/A
8'	2	8.25	20°	0.6	16	0.5	54	0.3	35	0.8	89	N/A	N/A	N/A	N/A	N/A
12'	3	8.25	20°	0.9	24	0.7	81	0.4	49	1.1	130	N/A	N/A	N/A	N/A	N/A

OPTIONAL HIGH OUTPUT LED LIGHTS (115 VOLT)

CASE LENGTH	CANOPY LIGHTS H.O. LED		OPTIONAL SHELF		MAX. H.O. LED LOAD	
	AMPS	WATTS	AMPS	WATTS	AMPS	WATTS
4'	N/A	N/A	N/A	N/A	N/A	N/A
6'	N/A	N/A	N/A	N/A	N/A	N/A
8'	N/A	N/A	N/A	N/A	N/A	N/A
12'	N/A	N/A	N/A	N/A	N/A	N/A

7. Electrical

Wiring Color Code

<i>Standard Case Wire Color Code</i>	
<u>Color Description</u>	<u>Color</u>
■ Ground	Green
■ Anti-Sweat	Purple
■ Lights	Orange
■ Receptacles	Yellow
■ T-Stat/Solenoid 230VAC	Red/Black
■ T-Stat/Solenoid 115VAC	White/Black
■ T-Stat/Solenoid 24VAC	Red/White
■ Fan Motors	Brown
Blue Condensing Unit	

Use Copper Conductors Only
430-01-0338 R101003

CASE MUST BE GROUNDED

NOTE: Refer to label illustrated above that is affixed to case to determine the actual configuration as checked in the "TYPE INSTALLED" boxes.

Electrical Circuit Identification

Standard lighting for all models will be full length fluorescent lamps located within the case at the top.

The switch controlling the lights, the plug provided for digital scale, and the thermometer are located at the rear of the case mullion.

The receptacle that is provided on the exterior back of these models is intended for computerized scales with a five amp maximum load, not for large motors or other high wattage appliances. It should be wired to a dedicated circuit.



DANGER

**BEFORE SERVICING
ALWAYS DISCONNECT ELECTRICAL
POWER AT THE MAIN DISCONNECT
WHEN SERVICING OR REPLACING ANY
ELECTRICAL COMPONENT.
This includes (but not limited to) Fans, Heaters
Thermostats, and Lights.**

Field Wiring and Serial Plate Amperage

Field Wiring must be sized for component amperes printed on the serial plate. Actual ampere draw may be less than specified. Field wiring from the refrigeration control panel to the merchandisers is required for refrigeration thermostats. Case amperes are listed on the wiring diagram, but always check the serial plate.

LED Driver Location

Drivers are located within the access panel that runs the length of the rear of the case. Refer to diagram on page 8.

8. Finishing Touches

If more than one RGD is being installed next to each other, the factory fitted continuous fascia may need to be installed. All fasciae rest on the top of their cases. The self contained fascia has a hook that needs to be slid through a gusset on the side of the case.

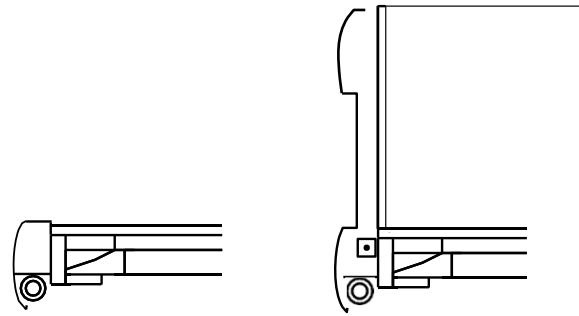

9. User Information

Stocking

Improper temperature and lighting will cause serious product loss. Discoloration, dehydration and spoilage can be controlled with proper use of the equipment and handling of product. Product temperature should always be maintained at a constant and proper temperature. This means that from the time the product is received, through storage, preparation and display, the temperature of the product must be controlled to maximize life of the product. Hussmann cases were not designed to “heat up” or “cool down” product - but rather to maintain an item’s proper temperature for maximum shelf life. To achieve the protection required always:

1. Minimize processing time to avoid damaging temperature rise to the product. Product should be at proper temperature.
2. Keep the air in and around the case area free of foreign gasses and fumes or food will rapidly deteriorate.
3. Maintain the display merchandisers temperature controls as outlined in the refrigerator section of this manual.
4. Do not place any product into these refrigerators until all controls have been adjusted and they are operating at the proper temperature. Allow merchandiser to operate a minimum of 6 hours before stocking with any product.
5. When stocking, never allow the product to extend beyond the recommended load limit. **Air discharge and return air flow must be unobstructed at all times to provide proper refrigeration.**
6. There are vents located at the base of the front of the glass, just above the front rail. These vents supply a continuous, gentle flow of air across the front glass which inhibits condensation. **Do not place any signs or other restrictive objects on the front of the refrigerator that will block these vents.**
7. Keep the service doors closed (when applicable). Refrigeration performance will be seriously affected if left open for a prolonged period of time.

8. Avoid the use of supplemental flood or spot lighting. Display light intensity has been designed for maximum visibility and product life at the factory. The use of higher output fluorescent lamps (H.O. and V.H.O.), will shorten the shelf life of the product.
9. In the Deli, Meat and Fish cases, completely cover the product each night with a clean damp cloth or butcher paper (never use plastic, as it does not allow for proper circulation). Make sure the cloth or paper is in direct contact with the product.
10. Turn and rotate the meat fairly often. The blood which gives the pink color works its way downward with time.
11. Cold coils remove heat and moisture from the case and deposit this as frost onto the coil. Thus, a defrost is required. Our humidity system induces moisture into the case and helps slow down the dehydration process. The only other moisture within the case is that in the product itself. A single level of meat will dry out faster than a fully loaded case of 3-4 levels of meat.

Important Steps

1. Do not set temperature too cold, as this causes product dehydration. **Product Temperature: 33°F-35°F!**
Set thermostat to cut in at 28°F discharge air. Meat holding box: 32°F. Meat prep room: 55°F. Meat bloom box: 36°F.
Process the meat to enter case at 40°F or below. Product deterioration is very rapid above 40°F.
2. Temperature control should be by means of a T-STAT and Suction Stop Solenoid at each case. Do not use EPR valves, Liquid Line Solenoids or electronic control devices of any kind, as these allow temperature swings causing dehydration and excessive energy consumption.
3. Product should be worked and rotated on a regular basis, not to exceed a 4-hour period.

User Information (Cont'd)

- At night, turn off case lights and cover the product with a damp (not wet) cloth similar to cheese cloth (etc.). This should be washed out in the morning and kept in a walk-in box during the day - so that it is cool and moist when covering the product.
- Discharge air temperature should be approximately 26°F, with between 150-200 FPM air velocity. Do not display product directly within the air discharge.
- Clean Humidity system a minimum of every 90 days for proper system operation.

Case Cleaning

Long life and satisfactory performance of any equipment are dependent upon the care given to it. To insure long life, proper sanitation and minimum maintenance costs, the refrigerator should be thoroughly cleaned frequently. SHUT OFF FAN DURING CLEANING PROCESS. It can be unplugged within the case, or shut off case at the source. The interior bottom may be cleaned with any domestic soap or detergent based cleaners. Sanitizing solutions will not harm the interior bottom, however, these solutions should always be used according to the manufacturer's directions. It is essential to establish and regulate cleaning procedures. This will minimize bacteria causing discoloration which leads to degraded product appearance and significantly shortening product shelf life.

Soap and hot water are not enough to kill this bacteria. A sanitizing solution must be included with each cleaning process to eliminate this bacteria.

- Scrub thoroughly, cleaning all surfaces, with soap and hot water.
- Rinse with hot water, but do not flood.
- Apply the sanitizing solution according to the manufacturer's directions.
- Rinse thoroughly.
- Dry completely before resuming operation.

Cleaning Glass and Mirrors

Only use a soft cloth and mild glass cleaner for cleaning any glass or mirrored components. Be sure to rinse and/or dry completely.

Never use hot water on cold glass surfaces! It may shatter and cause serious injury! Allow glass surfaces to warm first.



CAUTION

IF BY ANY REASON THE CUSTOMER MUST STORE THE CASE OTHER THAN ITS UPRIGHT POSITION. PLEASE ALLOW 2 HOURS MINIMUM PRIOR TO POWERING THE MERCHANDISER.

CAUTION

CLEANING PRECAUTIONS

When cleaning:

- Do not use high pressure water hoses
- Do not introduce water faster than waste outlet can drain
- NEVER INTRODUCE WATER ON SELF CONTAINED UNIT WITH AN EVAPORATOR PAN
- NEVER USE A CLEANING OR SANITIZING SOLUTION THAT HAS AN OIL BASE (these will dissolve the butyl sealants) or an AMMONIA BASE (this will corrode the copper components of the case)
- TO PRESERVE THE ATTRACTIVE FINISH:
- DO USE WATER AND A MILD DETERGENT FOR THE EXTERIOR ONLY
- DO NOT USE A CHLORANITED CLEANER ON ANY SURFACE
- DO NOT USE ABRASIVES OR STEEL WOOL SCOURING PADS (these will mar the finish)

Plexiglass and Acrylic Care

Cleaning

Clean with plenty of nonabrasive soap (or detergent) and luke warm water, using the bare hand to feel and dislodge any caked-on dirt. A soft, grit-free cloth, sponge or chamois may be used, but only as a means of carrying the water to the plastic. Dry with a clean damp chamois or clean soft cloth such as cotton flannel. Hard, rough cloths or paper towels will scratch the acrylic and should not be used.

NOTE: The base channel insert must slide out in order to be cleaned. A hose can be used for cleaning purposes of this base insert channel only when no end panel is provided on the case.

Waxing

If after removing dirt and grease, the acrylic can be waxed with a good grade commercial wax. This will improve the appearance of the surface by filling in most minor scratches. Wax should be applied in a thin even coat and brought to a high polish by rubbing lightly with a dry clean soft cloth, such as a cotton flannel. Excessive rubbing may cause scratching and/or buildup an electrostatic charge which attracts dust and dirt to the surface. Blotting with a clean damp cloth is recommended to remove charge.

Antistatic Coatings

For acrylic used indoors, antistatic coatings successfully prevent the accumulation of an electrostatic charge for periods of several months - if the surface is not washed or wiped down with a wet cloth. Between applications of the antistatic coatings, the parts need only be dusted with a soft clean cloth to maintain a good appearance. In use, liquid antistatic coatings should be applied in a very thin even coat. If beads appear as it is applied, the coat is too thick and the excess should be removed with another cloth. Allow the coating to dry, then bring to a high gloss with a soft cloth.

User Information (Cont'd)

LOADING BLIND SPRING

Night blinds are delivered pre-loaded. However, if it is necessary to load night blind spring, use a wrench (part number 0477098) to twist rectangular pin on right side of night blind. Twist clockwise 15 to 17 full revolutions.

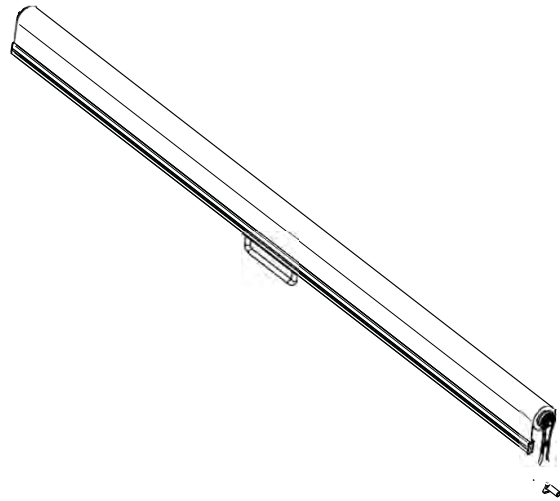

NOTE  Keep arrow / dot / up pointed up while winding. Keep pointed down when installed.

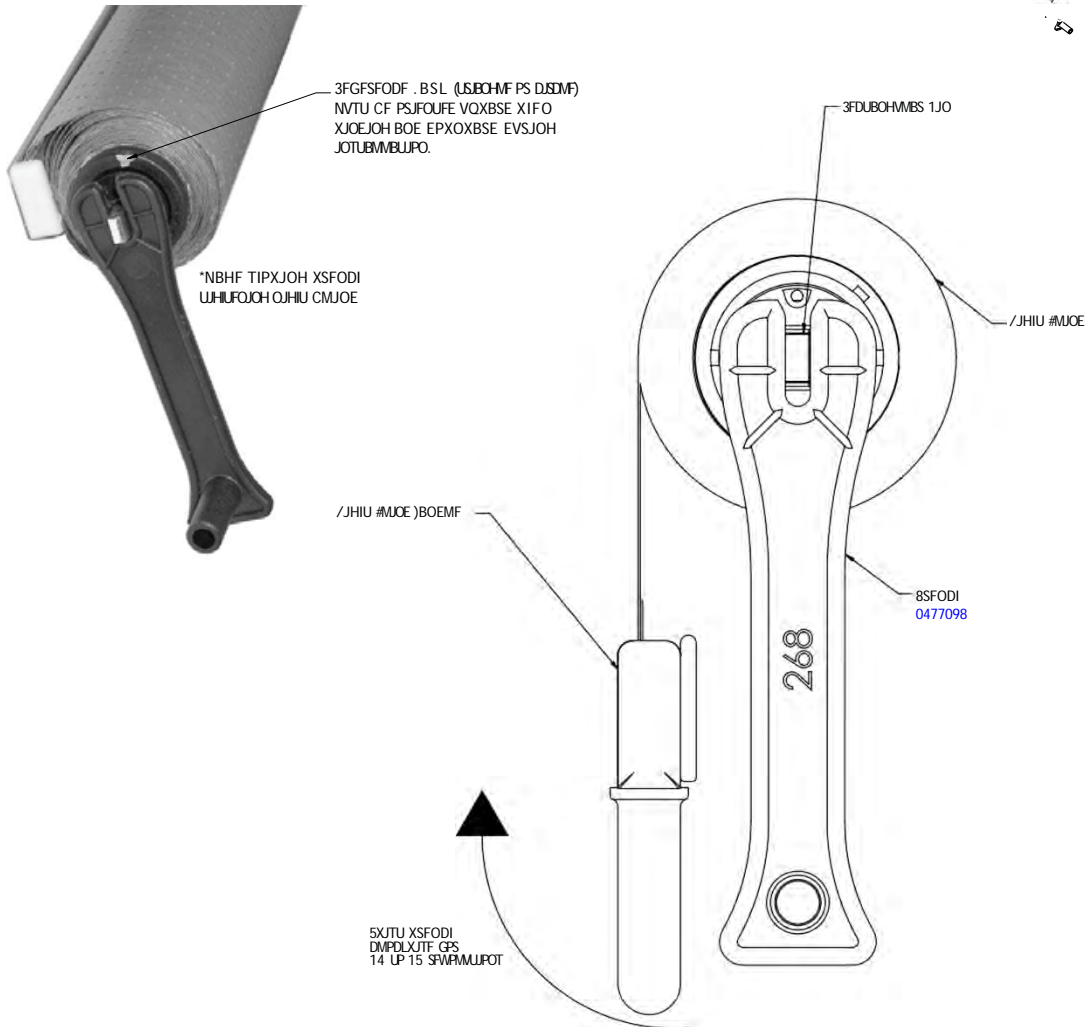

10. Maintenance



**BEFORE SERVICING
ALWAYS DISCONNECT ELECTRICAL
POWER AT THE MAIN DISCONNECT
WHEN SERVICING OR REPLACING ANY
ELECTRICAL COMPONENT.
This includes (but not limited to) Fans, Heaters
Thermostats, and Lights.**

Evaporator Fans

The evaporator fans are located at the center front of these merchandisers directly beneath the display pans. *Should fans or blades need servicing, always replace fan blades with the raised embossed side of the blade TOWARD THE MOTOR.*

Copper Coils

The copper coils used in Hussmann merchandisers may be repaired in the field. Materials are available from local refrigeration wholesalers.

Hussmann recommends using #15 Sil-Fos for repairs.

Tips and Troubleshooting

Before calling for service, check the following:

1. Check electrical power supply to the equipment for connection.
2. Check fixture loading. Overstocking case will affect its proper operation.
3. If frost is collecting on fixture and/or product, check that Humidity Control is working properly, and that no outside doors or windows are open - allowing moisture to enter store.



**IMPORTANT
INFORMATION**

**FOR PROMPT SERVICE
When contacting the factory,
be sure to have the Case Model and Serial
Number handy. This information is on a plate
located on the case itself.**

Maintenance (Cont'd)

Stainless Steel Cleaning and Care

There are three basic things, which can break down your stainless steel's passivity layer and allow corrosion.

1. Mechanical Abrasion

Mechanical Abrasion means those things that will scratch the steels surface. Steel Pads, wire Brushes, and Scrapers are prime examples.

2. Water

Water comes out of our tap in varying degrees of hardness. Depending on what part of the country you live in, you may have hard or soft water. Hard water may leave spots. Also, when heated, hard water leaves deposits behind that if left to sit, will break down the passive layer and rust your stainless steel. Other deposits from food preparation and service must be properly removed.

3. Chlorides

Chlorides are found nearly everywhere. They are in water, food and table salt. One of the worst perpetrators of chlorides can come from household and industrial cleaners.

Don't Despair! Here are a few steps that can help prevent stainless steel rust.

1. Use the Proper Tools

When cleaning your stainless steel products, take care to use non-abrasive tools. Soft Clothes and plastic scouring pads will NOT harm the steel's passive layer. Stainless steel pads can also be used but the scrubbing motion must be in the same direction of the manufacturer's polishing marks.

2. Clean With the Polish Lines

Some stainless steels come with visible polishing lines or "grain". When visible lines are present, you should ALWAYS scrub in a motion that is parallel to them. When the grain cannot be seen, play it safe and use a soft cloth or plastic scouring pad.

3. Use Alkaline, Alkaline Chlorinated or Non-chloride Containing Cleaners

While many traditional cleaners are loaded with chlorides, the industry is providing an ever increasing choice of non-chloride cleaners. If you are not sure of your cleaner's chloride content contact your cleaner supplier. If they tell you that your present cleaner contains chlorides, ask for an alternative. Also, avoid cleaners containing quaternary salts as they also can attack stainless steel & cause pitting and rusting.

4. Treat your Water

Though this is not always practical, softening hard water can do much to reduce deposits. There are certain filters that can be installed to remove distasteful and corrosive elements. Salts in a properly maintained water softener are your friends. If you are not sure of the proper water treatment, call a treatment specialist.

5. Keep your Food Equipment Clean

Use alkaline, alkaline chlorinated or non-chlorinated cleaners at recommended strength. Clean frequently to avoid build-up of hard, stubborn stains. If you boil water in your stainless steel equipment, remember the single most likely cause of damage is chlorides in the water. Heating cleaners that contain chlorides has a similar effect.

6. RINSE, RINSE, RINSE

If chlorinated cleaners are used you must rinse, rinse, rinse and wipe dry immediately. The sooner you wipe off standing water, especially when sit contains cleaning agents, the better. After wiping the equipment down, allow it to air dry for the oxygen helps maintain the stainless steel's passivity film.

7. Never Use Hydrochloric Acid (Muriatic Acid) on Stainless Steel

8. Regularly Restore/Passivate Stainless Steel

11. Controller Data

Function	Codes	Min	Max	Factory Setting	RGD TYPE1	RGD TYPE 2
Normal Operation						
Temperature (Set Point)	--	-50°C	50°C	2°C	24°F	24°F
Thermostat						
Differential	r01	0.1K	20K	2K	8	4
Max. limitation of setpoint setting	r02	-49°C	50°C	50°C	32°F	32°F
Min. limitation of setpoint setting	r03	-50°C	49°C	-50°C	24°F	20°F
Temperature Unit (C/F)	r05	°C	°F	°C	°F	°F
Manual Service (-1), Stop Regulation (0), Start Regulation (1)	r12	-1	1	0	1	1
Alarm						
Compressor						
Defrost						
Defrost Method (EL/Gas/Brine)	d01	no	Gas	EL	EL	EL
Defrost Stop Temperature	d02	0°C	25°C	6°C	48°F	48°F
Interval between defrost starts (Hours)	d03	0	48	8	6	2
Maximum Defrost duration (Minutes)	d04	0	180	45	25	15
Defrost Sensor (0=Time, 1=S5, 2=S4)	d10	0	2	0	0	0
Fans						
HACCP						
Real Time Clock						
Miscellaneous						
Service						

12. RGD Check List

- Check cases in and evaluate for missing or loose parts on each unit
- Create a list of any parts that are missing or damaged along with photos of damaged parts and submit PM to obtain parts (Aftermarket Parts)
- Ensure all lighting, including canopy and shelves, are fully functional
- Ensure that all case settings are intact by;
 - 1) Accessing the case controller

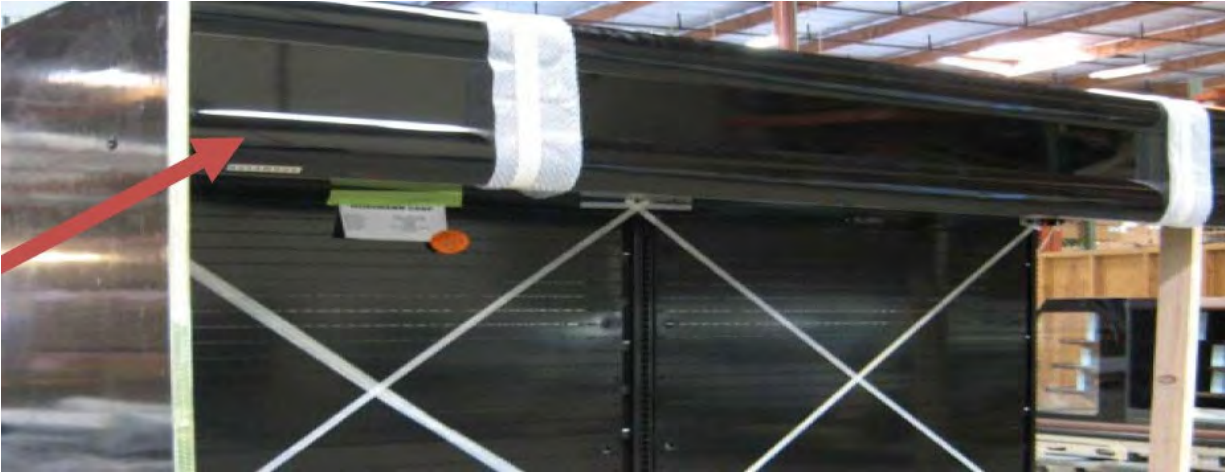

- 2) Check the Danfoss AKC-210-CC controller's set point is 24 degrees



13. Electrical Wiring Diagrams

RGD-24-72-3-SC R-404/448	3'	3127775
RGD-24-72-3'9"-SC R-404/448	3'9"	3127776
RGD-24-72-4-SC R-448	4'	3127777
RGD-30-72-4-SC R-448	4'	3127778
RGD-24-72-5-SC R-404/448	5'	3127779
RGD-30-72-5-SC R-404/448	5'	3127780
RGD-24-72-6-SC R-404/448	6'	3127781
RGD-30-72-6-SC R-404/448	6'	3127782
RGD-24-72-8-SC R-448	8'	3127783
RGD-30-72-8-SC R-448	8'	3127784

RGD-3'9-R 24 & 30 X 72, 24 & 30 X 83	3'9"	3013101
RGD-4-R 24 & 30 X 72, 24 & 30 X 83	4'	3013100
RGD-5-R 24 & 30 X 72, 24 & 30 X 83	5'	3013099
RGD-6-R 24 & 30 X 72, 24 & 30 X 83	6'	3013098
RGD-8-R 24 & 30 X 72, 24 & 30 X 83	8'	3013097
RGD-10-R 24 & 30 X 72, 24 & 30 X 83	10'	3013096
RGD-12-R 24 & 30 X 72, 24 & 30 X 83	12'	3013095
RGDC-3'9-R 24 & 30 X 72, 24 & 30 X 83	3'9"	3013151

RGD-24-72-3-S W/XR75 CTRLR	3'	3160912
RGD-24-72-4R-S/XR75 CTRLR	4'	3157196
RGD-24-72-3'9"-S W/XR75 CTRLR	45"	3165420
RGD-24-72-5-S W/XR75 CTRLR	5'	3168017
RGD-24-72-6-S W/XR75 CTRLR	6'	3164576
RGD-24-72-8-S W/XR75 CTRLR	8'	3160937
RGD-30-72-4-S W/XR75 CTRLR	4'	3157197
RGD-30-72-5-S W/XR75 CTRLR	5'	3164902
RGD-30-72-6-S W/XR75 CTRLR	6'	3157201
RGD-30-72-8-S W/XR75 CTRLR	8'	3160914

REV	ECN	DATE	REVISION DESCRIPTION	REV BY	CHKD BY	APPR BY
B	ECN-C00-0014512	11-30-21	NEW LIGHT	CB	CB	CB
C	FAN-C00-0018013	1-3-24	CHANGED FAN MOTOR	CB	CB	CB

REVISION HISTORY
COND. PUMPS BECKETT™ CB15UL1Z 225-01-1661 120V 17A
PLUG NEMA 5-15P

LOADING	240 V
L1	15.6
L2	16.3

CIRCUIT #1	LOADING
L1	15.6
L2	16.3

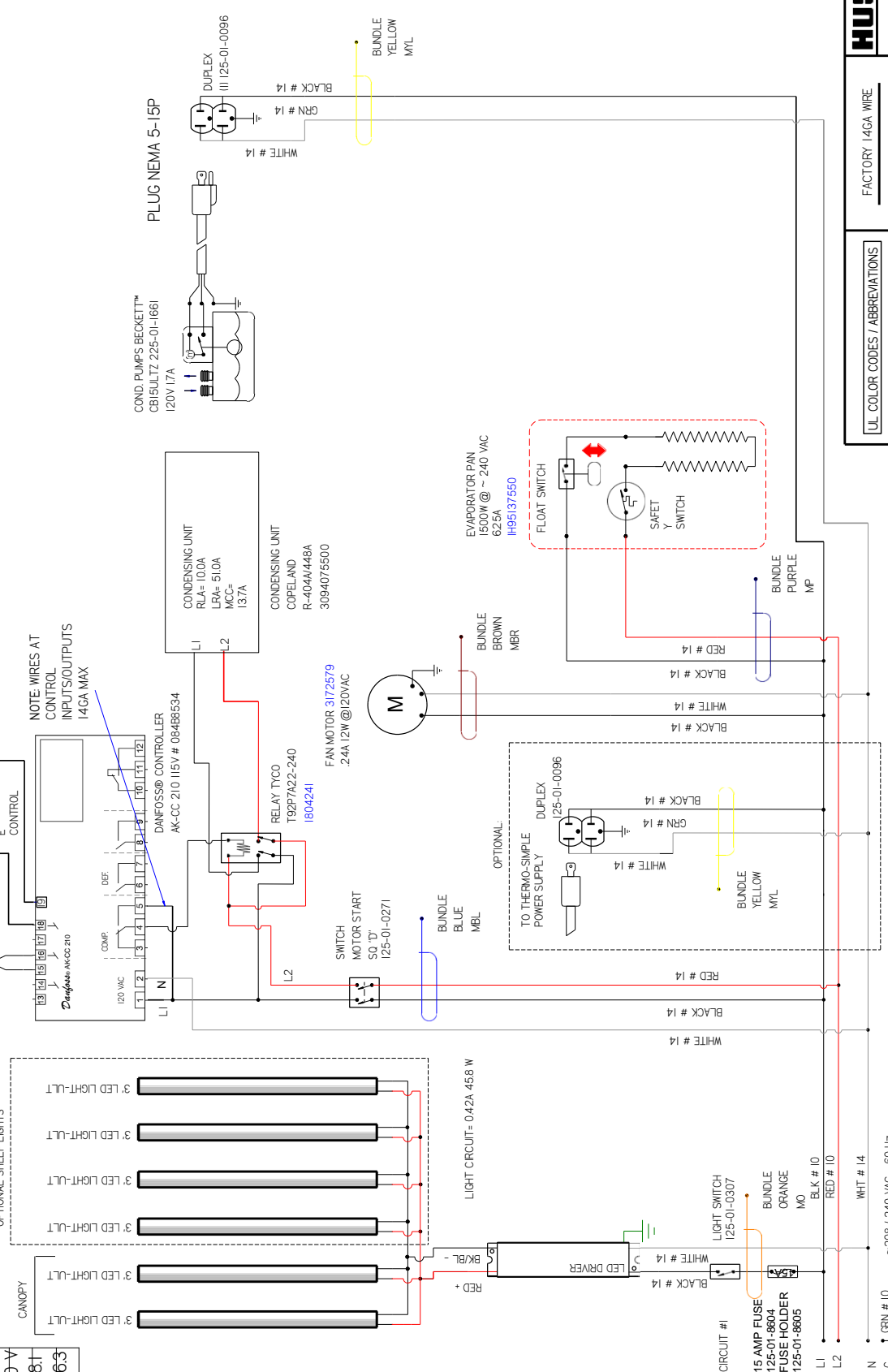

NOTE: 1. PRINTED DOCUMENT REQUIRED SETTING- ALL COLORS BLACK & WHITE.
 2. CASE & ANY REMOVABLE PANEL WITH ELECTRICAL PARTS. MUST BE GROUNDED.
 3. WHEN PASSING WIRES THROUGH METAL HOLES A GROMMET MUST BE USED.

UL COLOR CODES / ABBREVIATIONS	
RED = RD	WHITE = WT
BLACK = BK	GREEN = GN
BLUE = BL	BROWN = BN
YELLOW = YL	ORANGE = OR
YL GRAY = GY	OR VIOLET = VT

FACTORY 14GA WIRE
FACTORY 10GA WIRE
FIELD WIRE

DO NOT SCALE DRAWING
 SHEET 1 OF 1

HUSSMANN
 DIAGRAM-RGD-24-7
 2-39"-SC

3127776

183

183

183

183

183

183

183

183

183

183

183

183

183

183

183

183

183

183

CIRCUIT #1
LOADING

Z06V	Z4U
L1	L5
L4	L3
L	L

2

REV	ECN	DATE	REVISION DESCRIPTION	REV BY	CHKD BY	APPR BY
C	ECN-C00-0014512	12-1-21	NEW LIGHTS	CB	CB	CB
D	ECN-C00-00189013	1-3-24	CHANGED FAN MOTOR	CB	CB	CB

REVISION HISTORY

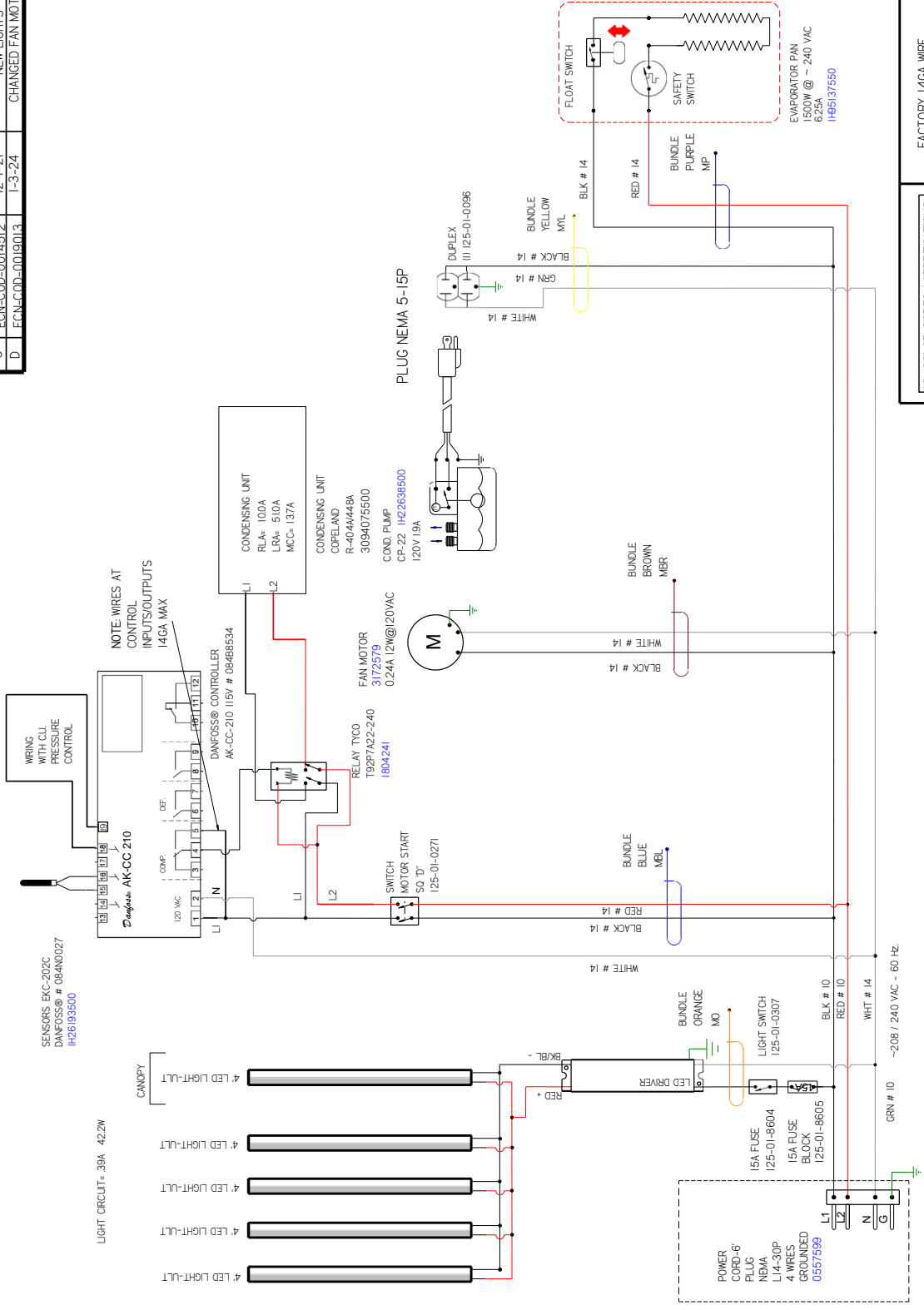

- NOTES:
1. PRINTED DOCUMENT REQUIRED SETTING: ALL COLORS BLACK & WHITE
 2. CASE & ANY REMOVABLE PANEL WITH ELECTRICAL PARTS MUST BE GROUNDED.
 3. WHEN PASSING WIRES THROUGH METAL HOLES A GROMMET MUST BE USED

HUSSMANN

DIAGRAM-RGD-24-7
2-4-SC

FACTORY 14GA WIRE
_FACTORY_10GA WIRE
FIELD WIRE

DO NOT SCALE DRAWING
SHEET 1 OF 1

3127777

REV	ECN	DATE	REVISION DESCRIPTION	REV BY	CHKD BY	APPR BY
B	ECN-C00-0014512	12-1-21	NEW LIGHTS	CB	CB	CB
C	ECN-C00-0018913	1-3-24	CHANGED FAN MOTOR	CB	CB	CB

REV	ECN	DATE	REVISION DESCRIPTION	REV BY	CHKD BY	APPR BY
B	ECN-C00-0014512	12-1-21	NEW LIGHTS	CB	CB	CB
C	ECN-C00-0018913	1-3-24	CHANGED FAN MOTOR	CB	CB	CB

LOADING	208	240-V
L1	15.7	18.2
L2	14.1	16.3

REVISION HISTORY
SENSOR EXC-202C DANFOSS # 084N0027 H26193500
NOTE: WIRES AT CONTROL INPUTS/OUTPUTS 14GA MAX

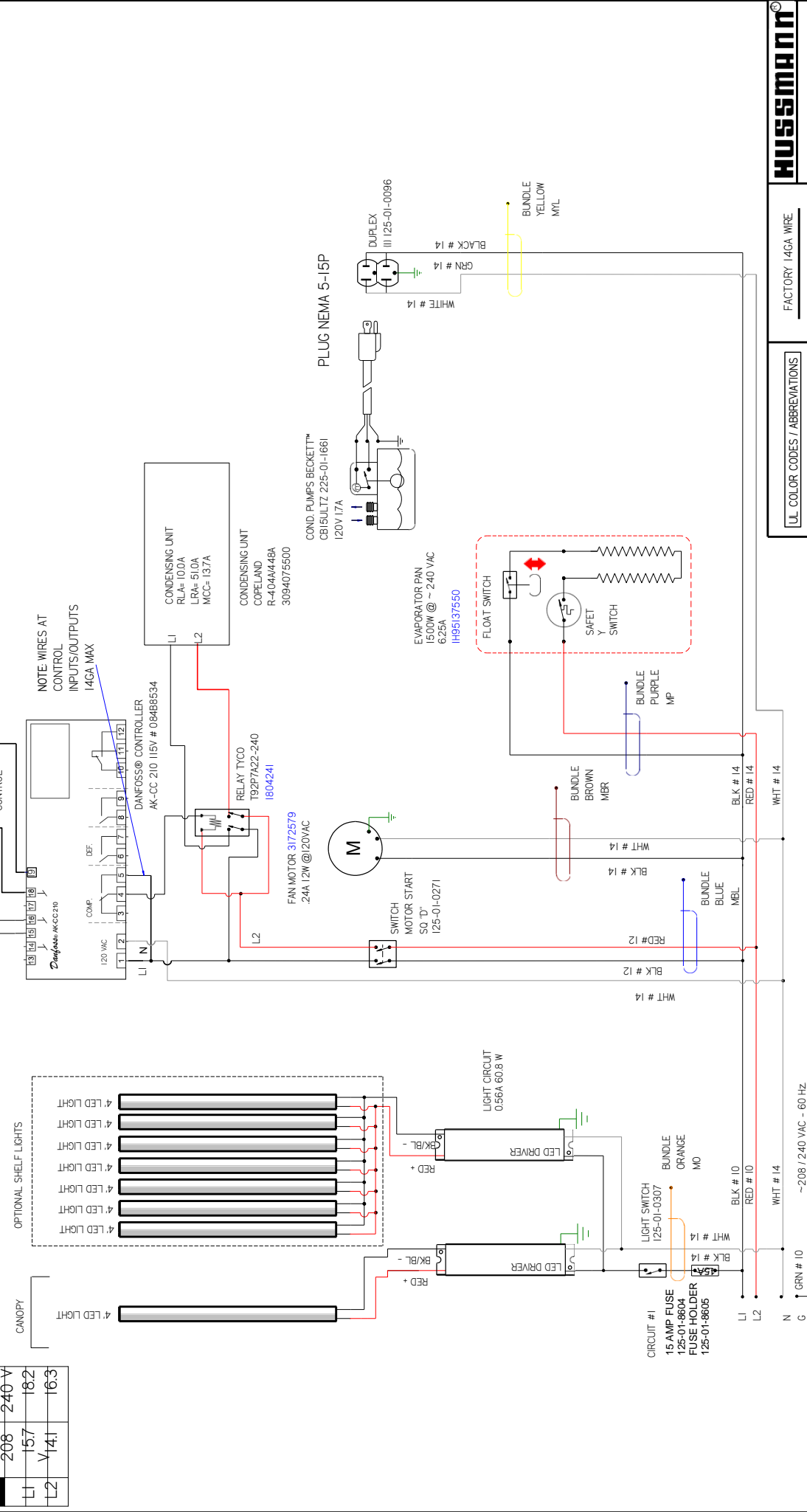

UL COLOR CODES / ABBREVIATIONS

- RED = RD
- BLACK = BK
- BLUE = BL
- YELLOW = YL
- GRAY = GR
- WHITE = WT
- GREEN = GN
- BROWN = BN
- ORANGE = OR
- OR VIOLET = VT

FACTORY 14GA WIRE

- FACTORY 14GA WIRE
- FIELD WIRE

DO NOT SCALE DRAWING

SHEET 1 OF 1

HUSSMANN

DIAGRAM-RGD-30-7

2-4-SC

3127778

183

NOTES:

- PRINTED DOCUMENT REQUIRED SETTING: ALL COLORS BLACK & WHITE
- CASE & ANY REMOVABLE PANEL WITH ELECTRICAL PARTS MUST BE GROUNDED.
- WHEN PASSING WIRES THROUGH METAL HOLES A GROMMET MUST BE USED

CIRCUIT #1

LOADING	
208V/240 V	
L1	18.7
L2	16.4
	18.9

CANOPY LIGHTS
5 LED LIGHT

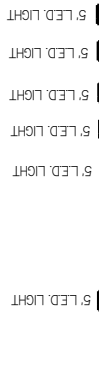

LIGHT CIRCUIT = 57A 61.4W



REVISION HISTORY			
REV	ECN	DATE	REVISION DESCRIPTION
B	ECN-C00-0014512	12-2-21	NEW LIGHTS
C	ECN-C00-0018913	1-4-24	CHANGED FAN MOTORS

REV	CHKD BY	APPR BY
B	CB	CB
C	CB	CB

EVAPORATOR PAN	
1500W @ - 240 VAC	
625A	
IH95137550	



COND. PUMPS BECKETT™	
CB15 IUL1Z 225-01-1661	
1.7A @120VAC	

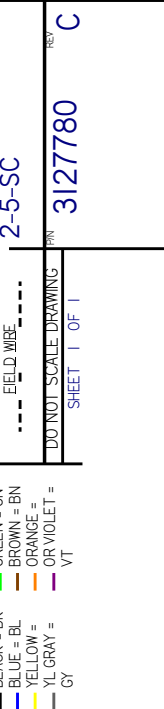
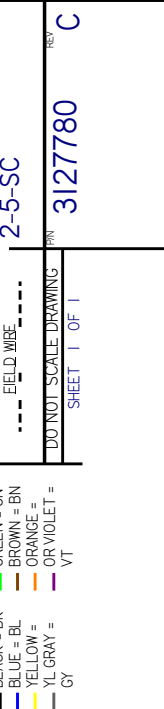
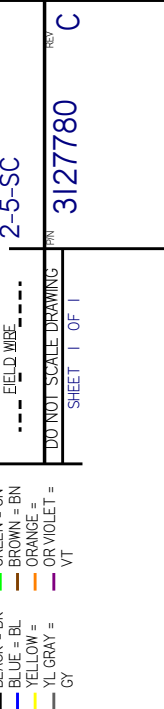
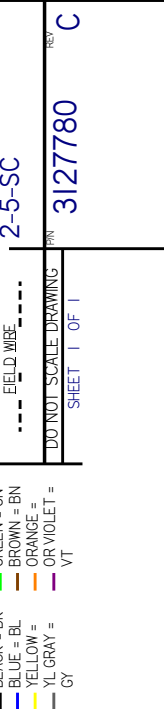
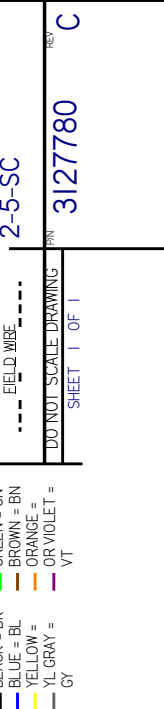
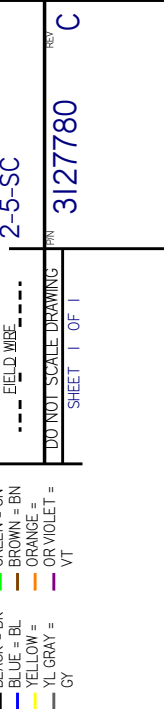
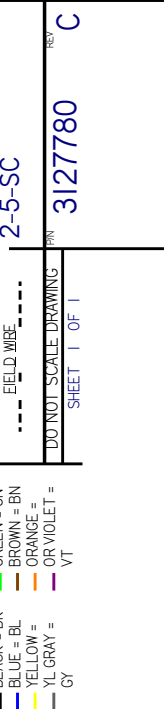
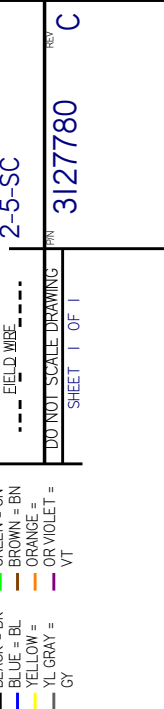
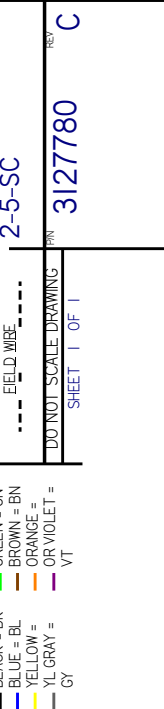
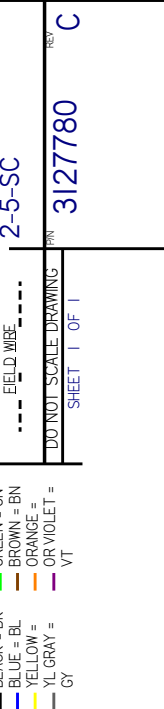
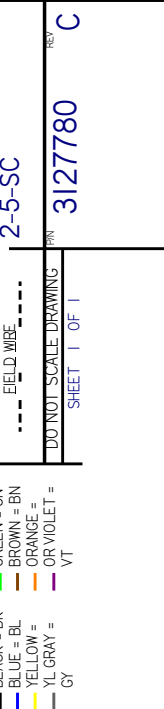
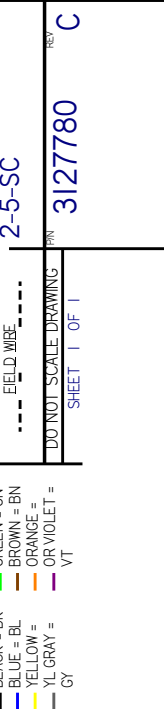
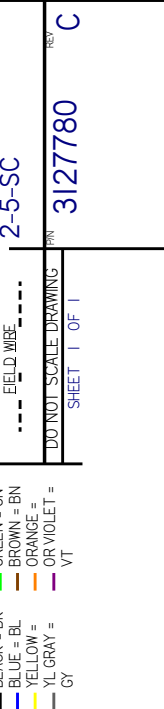
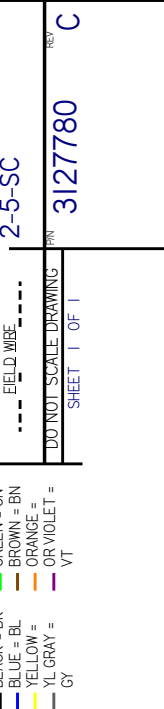
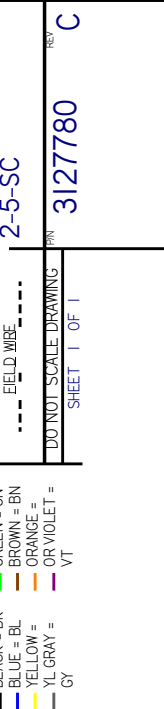
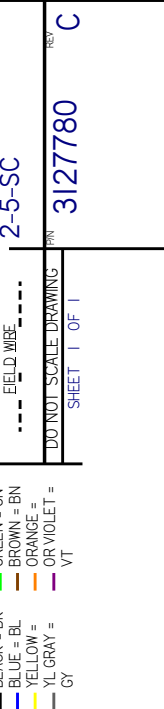
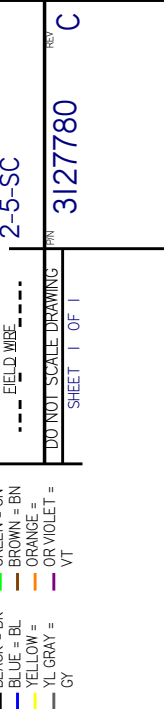
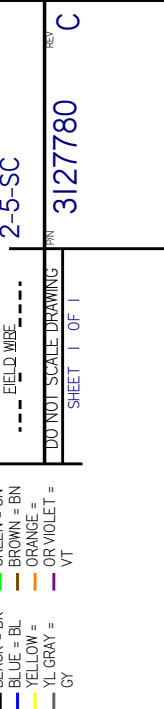
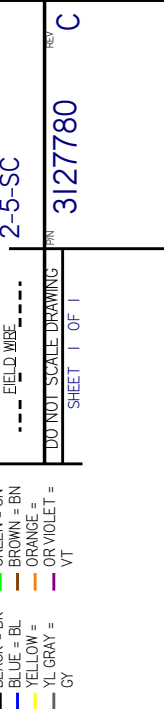
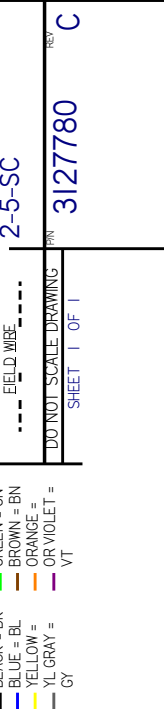
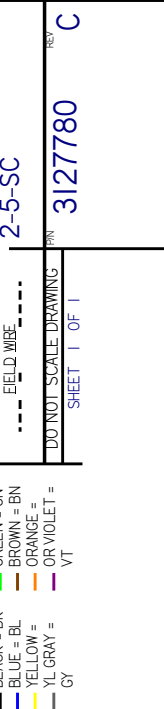
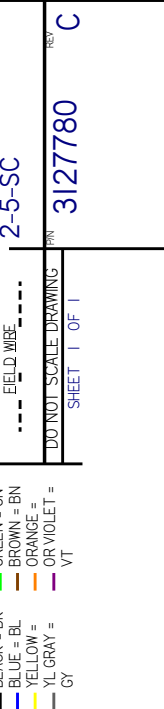
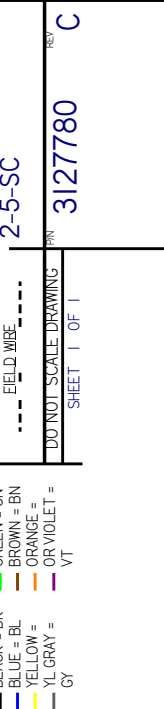
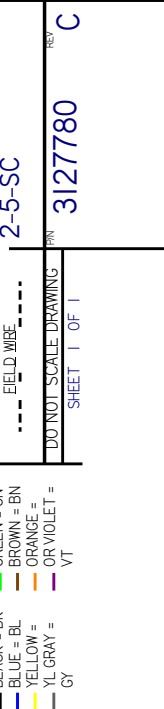
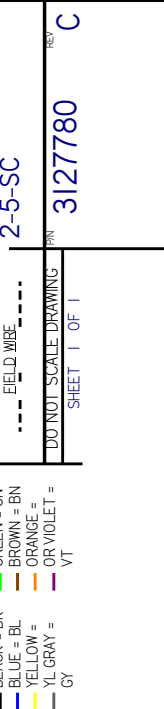
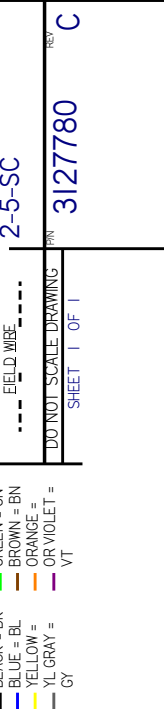
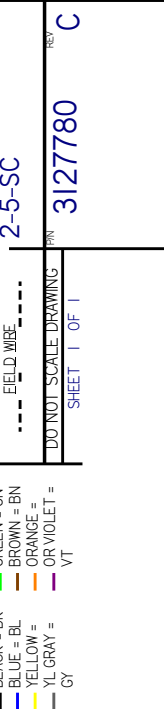
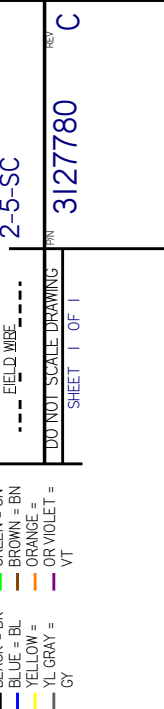
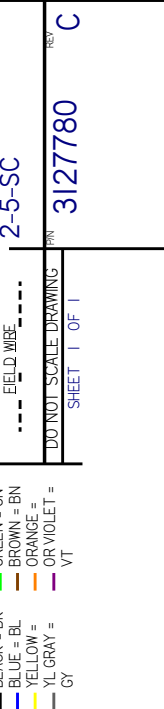
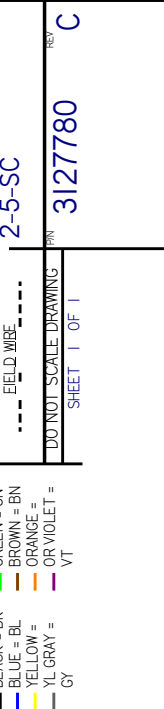
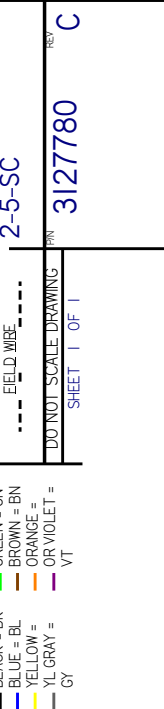
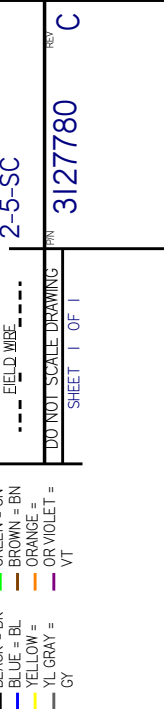
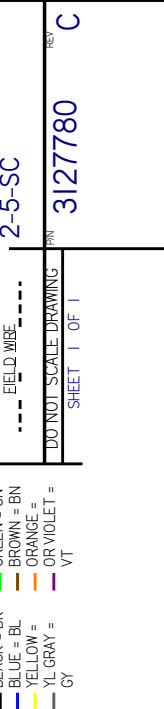
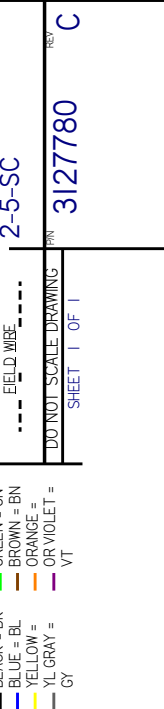
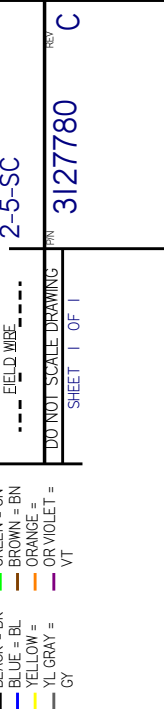
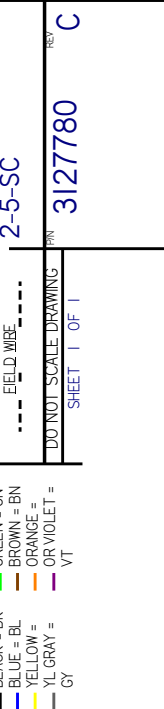
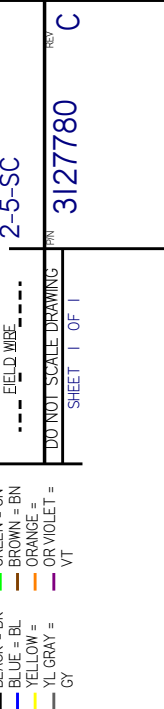
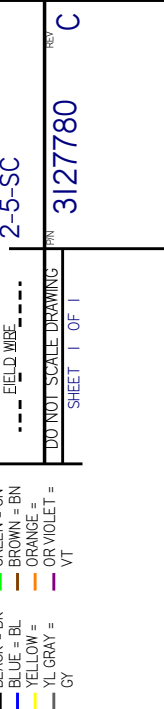
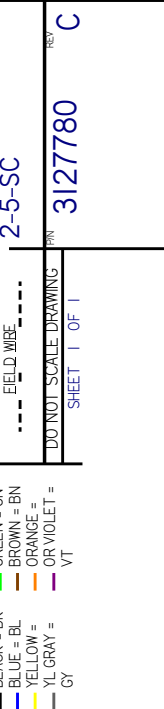
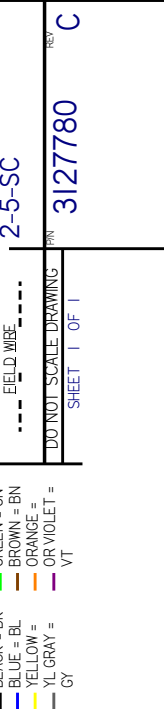
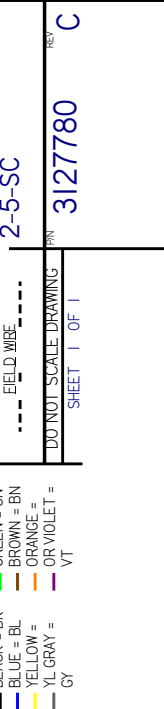
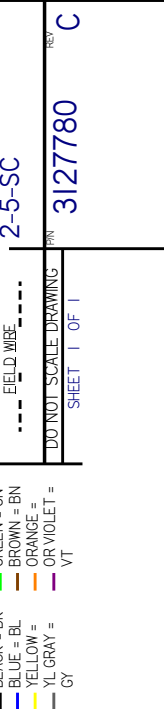
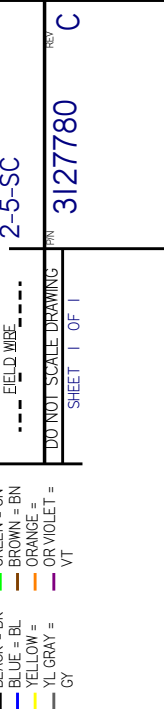
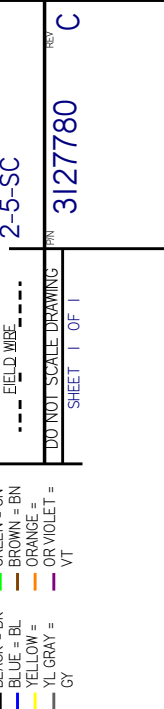
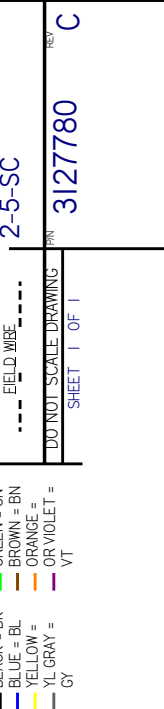
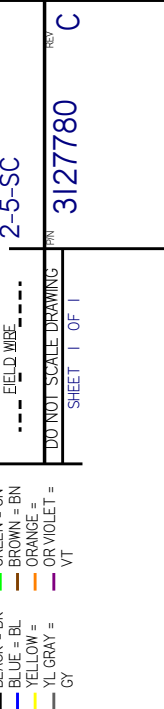
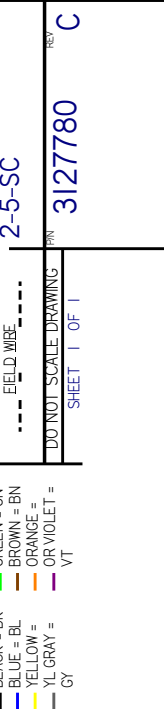
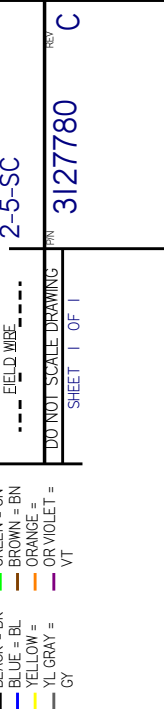
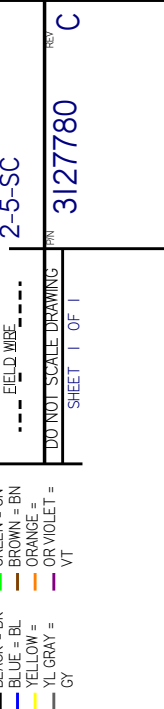
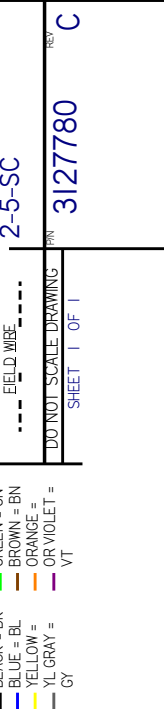
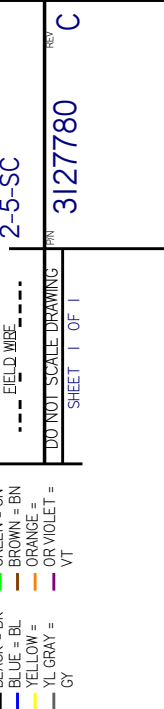
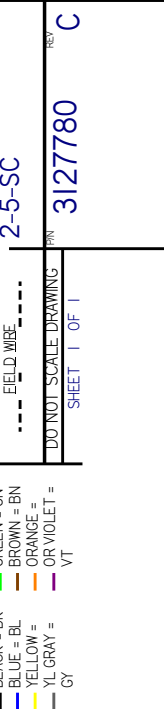
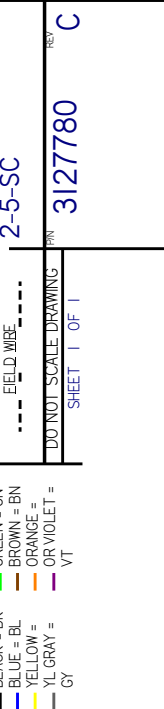
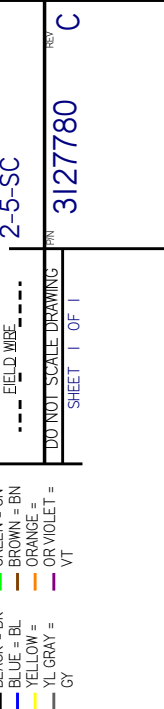
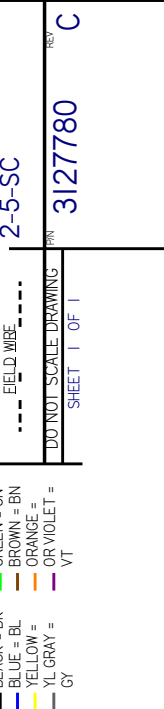
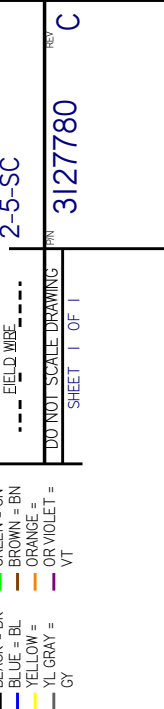
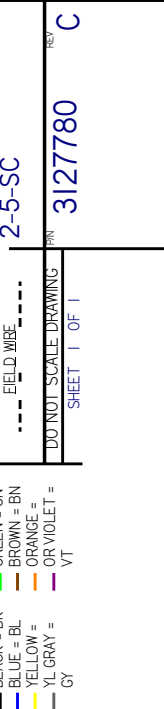
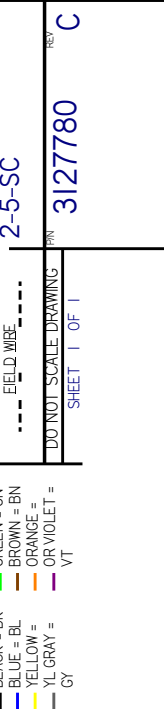
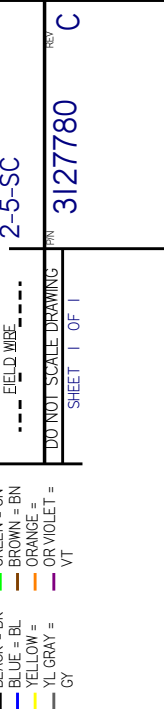
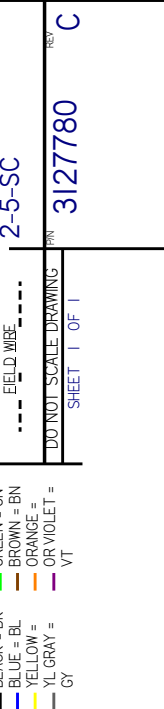
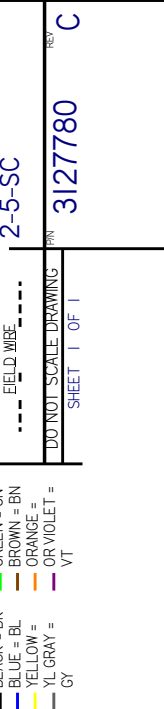
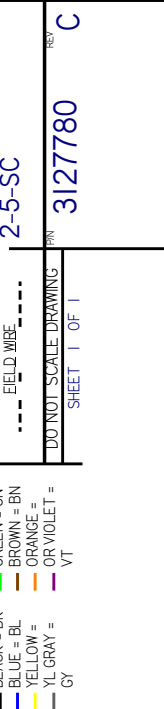
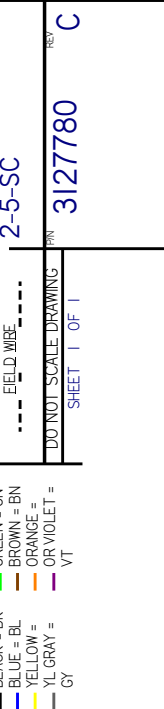
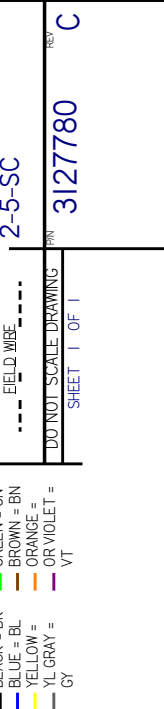
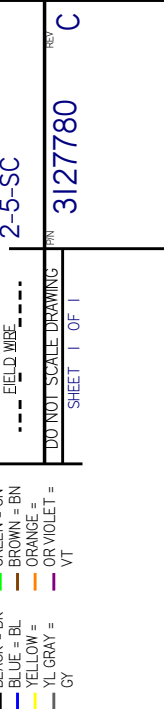
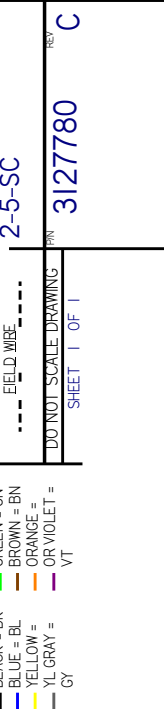
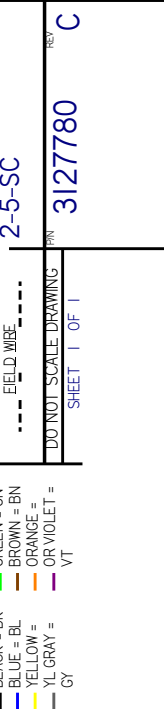
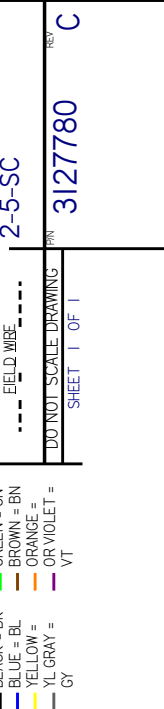
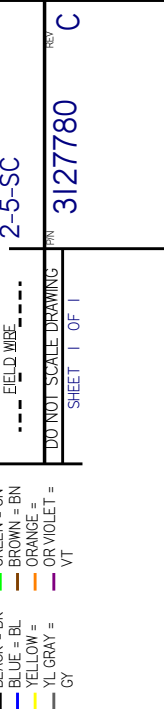
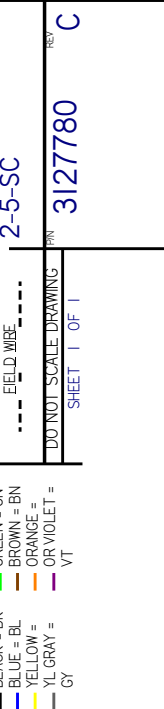
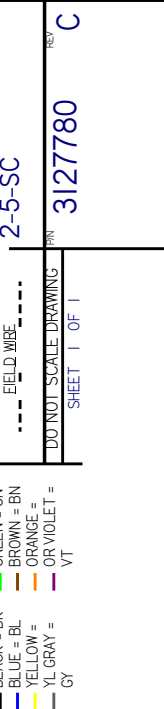
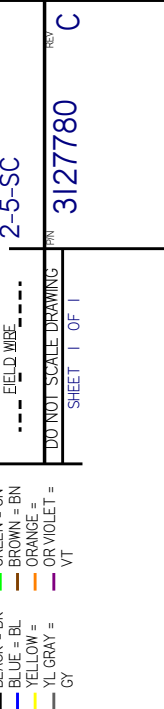
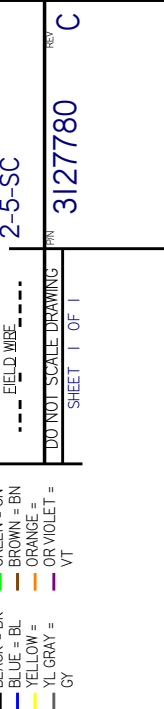
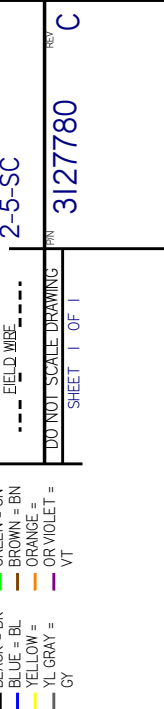
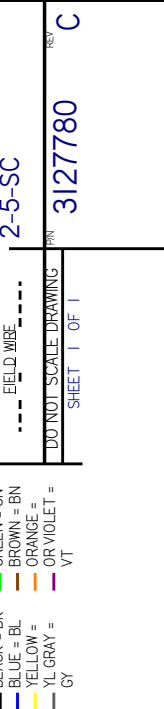
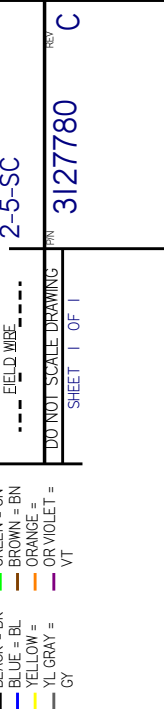
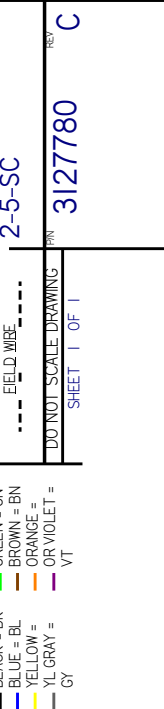
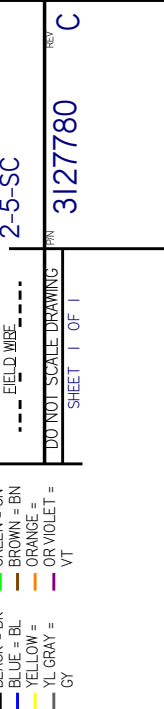
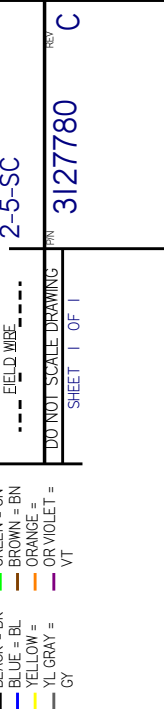
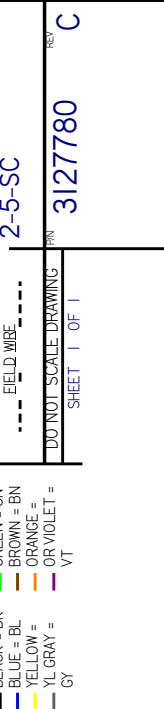
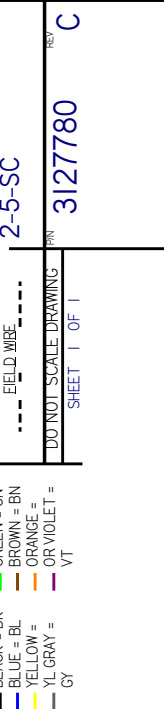
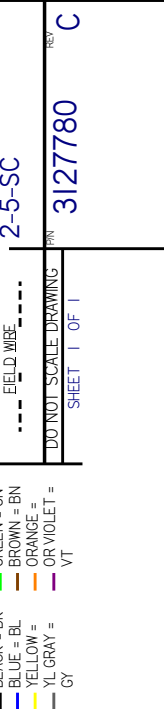
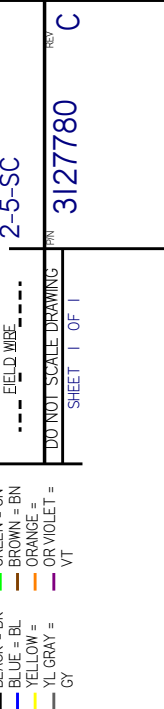
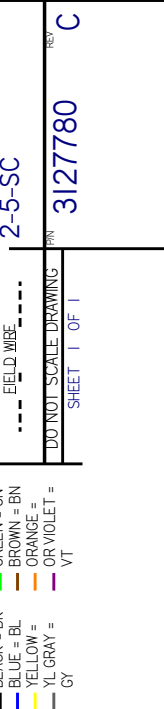
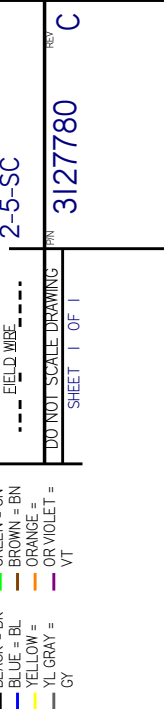
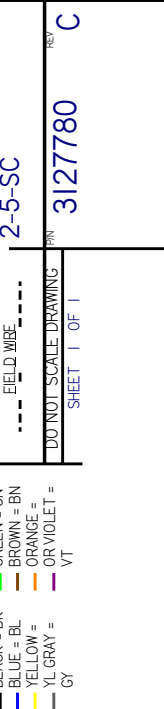
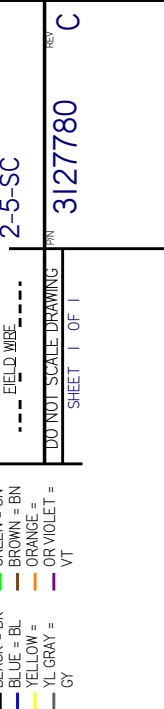
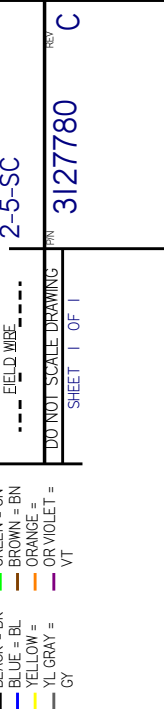
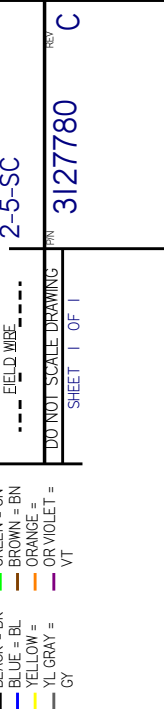
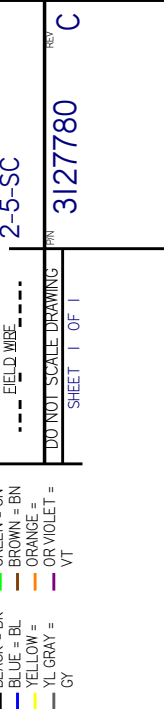
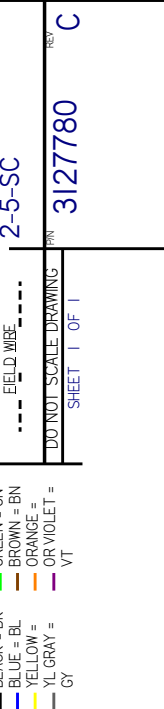
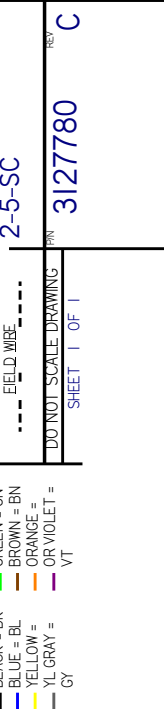
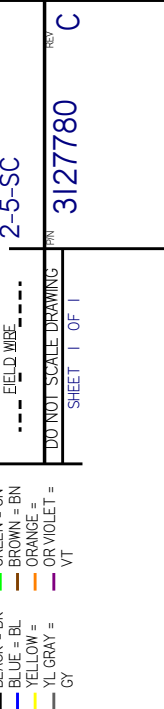
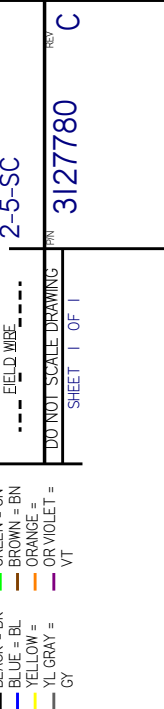
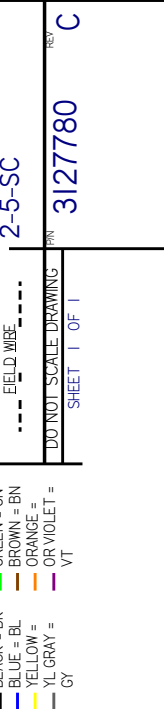
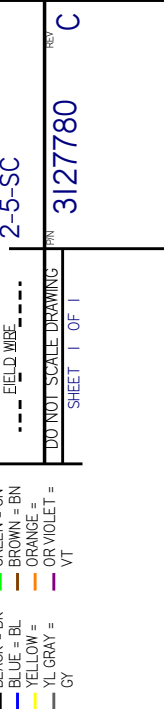
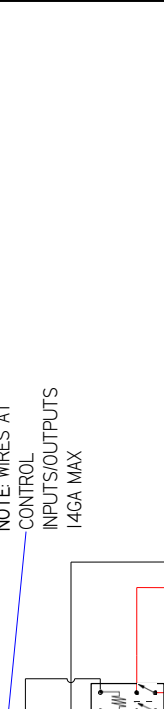
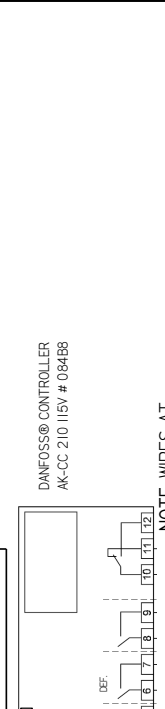

CIRCUIT #1

LOADING
208V/240 V
L1 190 22.
L2 16.4 18.9

CANOPY LIGHTS

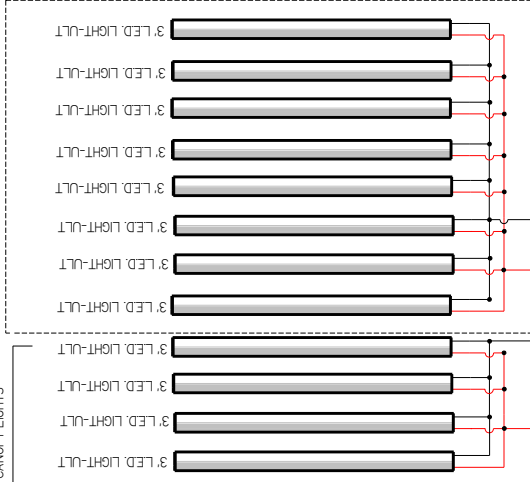

OPTIONAL SHELF LIGHTS



REV	ECN	DATE	REVISION DESCRIPTION	REV BY	CHKD BY	APPR BY
B	ECN-COD-001451/3	12-3-21	NEW LIGHTS	CB	CB	CB
C	ECN-COD-001801/3	1-4-24	CHANGED FAN MOTORS	CB	CB	CB

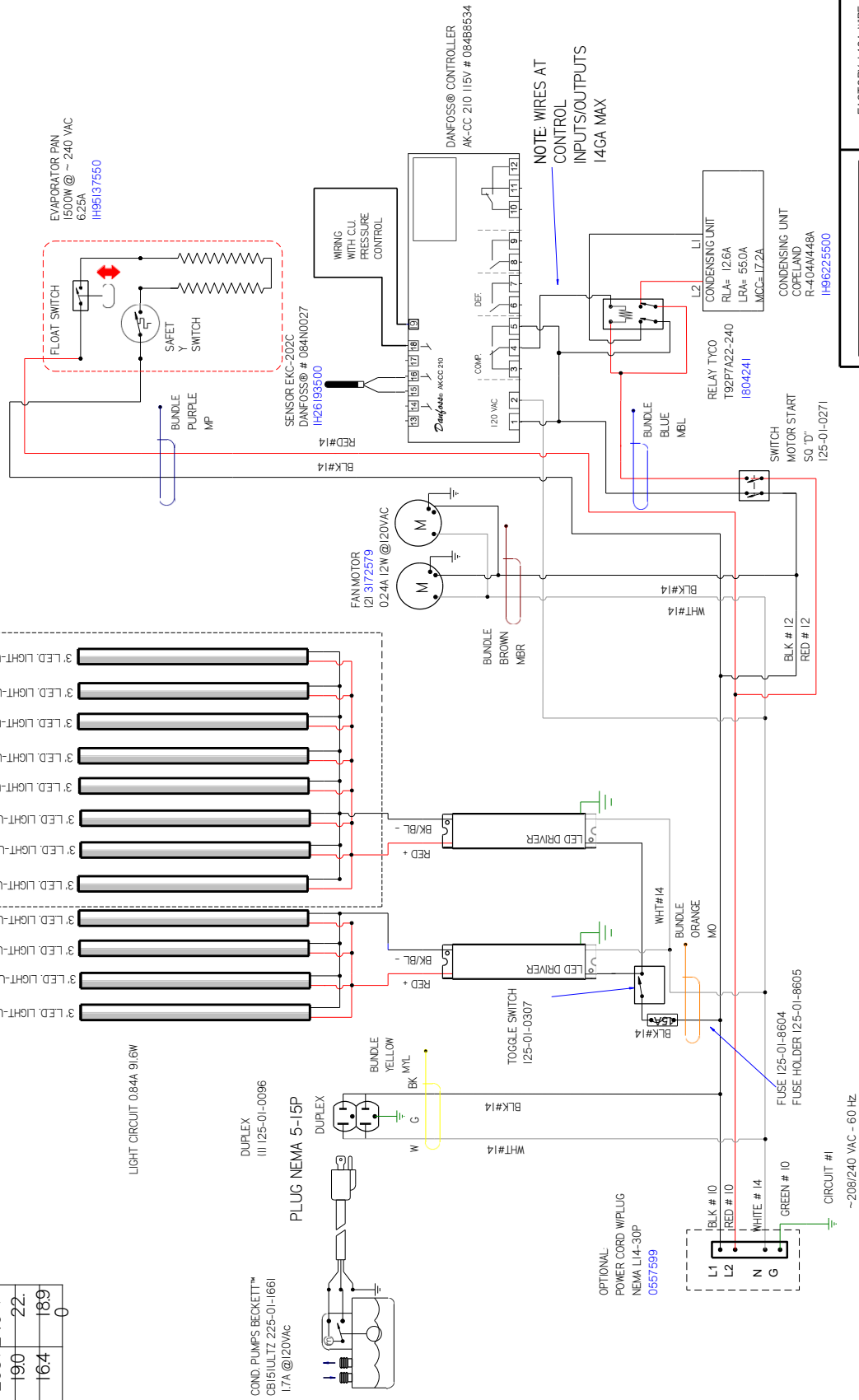

- NOTES:
1. PRINTED DOCUMENT REQUIRED SETTING: ALL COLORS BLACK & WHITE
 2. CASE & ANY REMOVABLE PANEL WITH ELECTRICAL PARTS MUST BE GROUNDED.
 3. WHEN PASSING WIRES THROUGH METAL HOLES A GROMMET MUST BE USED

HUSSMANN
DIAGRAM-RGD-24-7
2-6-SC

FACTORY 14GA WIRE
 _FACTORY LOGA WIRE
 _ _ _ _ _ FIELD WIRE
 _ _ _ _ _ DO NOT SCALE DRAWING
 SHEET 1 OF 1

UL COLOR CODES / ABBREVIATIONS
 RED = RD
 BLACK = BK
 BLUE = BL
 YELLOW = YL
 GRAY = GR
 WHITE = WT
 GREEN = GN
 BROWN = BN
 ORANGE = OR
 PURPLE = VT

3127781

REV C

CIRCUIT #1

LOADING
208V/240 V
L1 190 22.
L2 16.4 18.9

COND. PUMPS BECKETT™
CB15ULTZ 225-01-1661
1.7A @120VAC

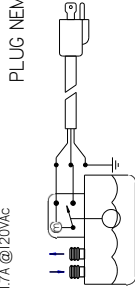

DUPLEX
III 125-01-0096

PLUG NEMA 5-15P

CANOPY LIGHTS

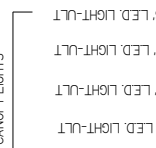

OPTIONAL SHELF LIGHTS

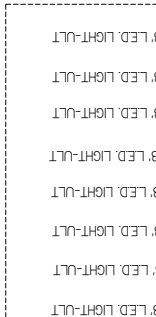

LIGHT CIRCUIT 084A, 91.6W

DUPLEX
III 125-01-0096

PLUG NEMA 5-15P

REV	ECN	DATE	REVISION DESCRIPTION	REV BY	CHKD BY	APPR BY
B	ECN-COD-001451/3	12-3-21	NEW LIGHTS	CB	CB	CB
C	ECN-COD-001801/3	1-4-24	CHANGED FAN MOTORS	CB	CB	CB

REVISION HISTORY

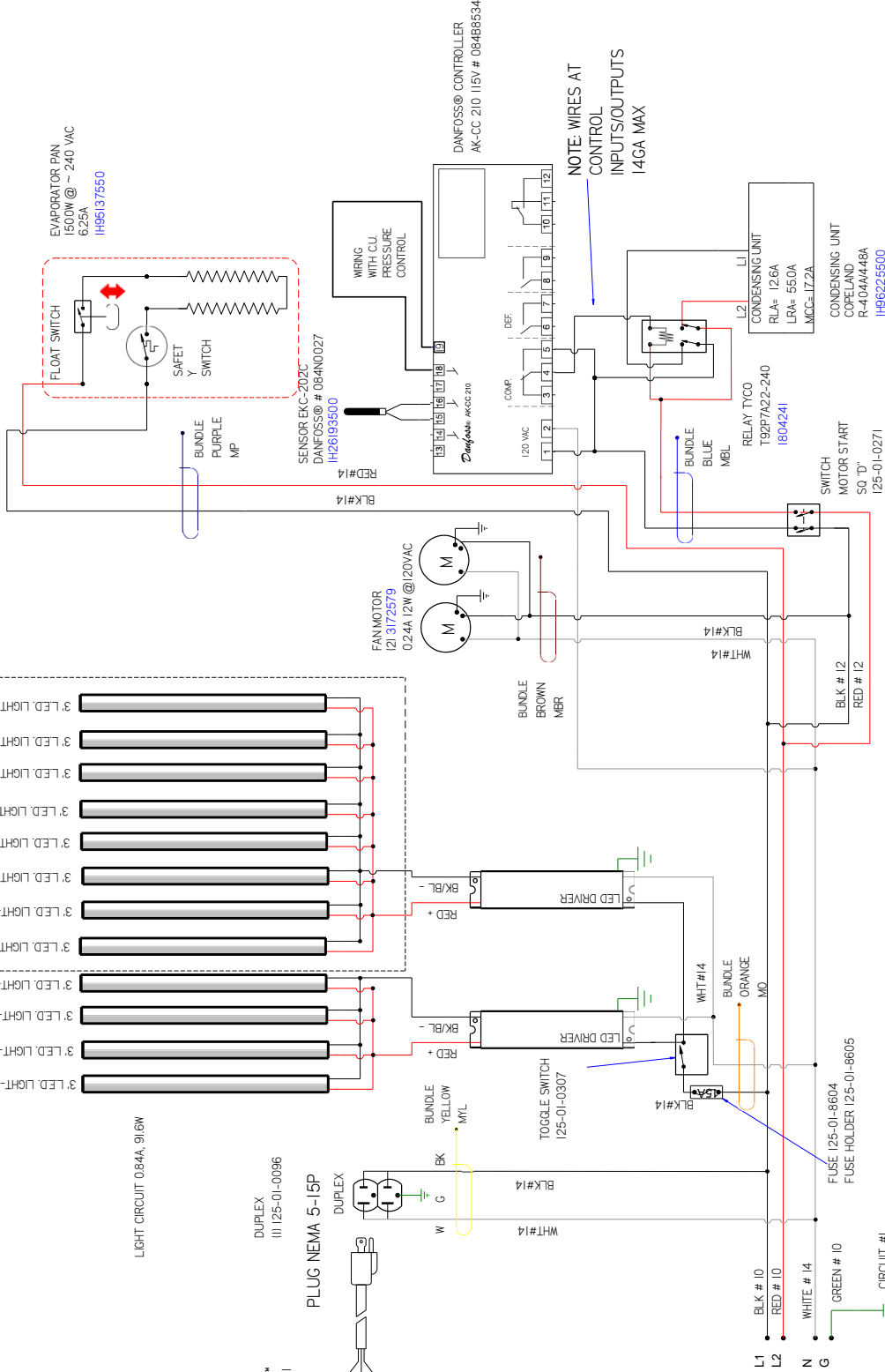

- NOTES:
1. PRINTED DOCUMENT REQUIRED SETTING: ALL COLORS BLACK & WHITE
 2. CASE & ANY REMOVABLE PANEL WITH ELECTRICAL PARTS MUST BE GROUNDED.
 3. WHEN PASSING WIRES THROUGH METAL HOLES A GROMMET MUST BE USED

HUSSMANN

DIAGRAM-RGD-30-7
2-6-SC

FACTORY 14GA WIRE

FACTORY LOGA WIRE

FIELD WIRE

DO NOT SCALE DRAWING

SHEET 1 OF 1

3127782

CIRCUIT #1

LOADING
120 V
L1 3:1

REVISION HISTORY

REV	ECN	DATE	REVISION DESCRIPTION	REV BY	CHKD BY	APPR BY
B	ECN-C00-001451/3	12-3-21	NEW LIGHTS	CB	CB	CB
C	ECN-C00-001801/3	1-4-24	CHANGED FAN MOTORS	CB	CB	CB

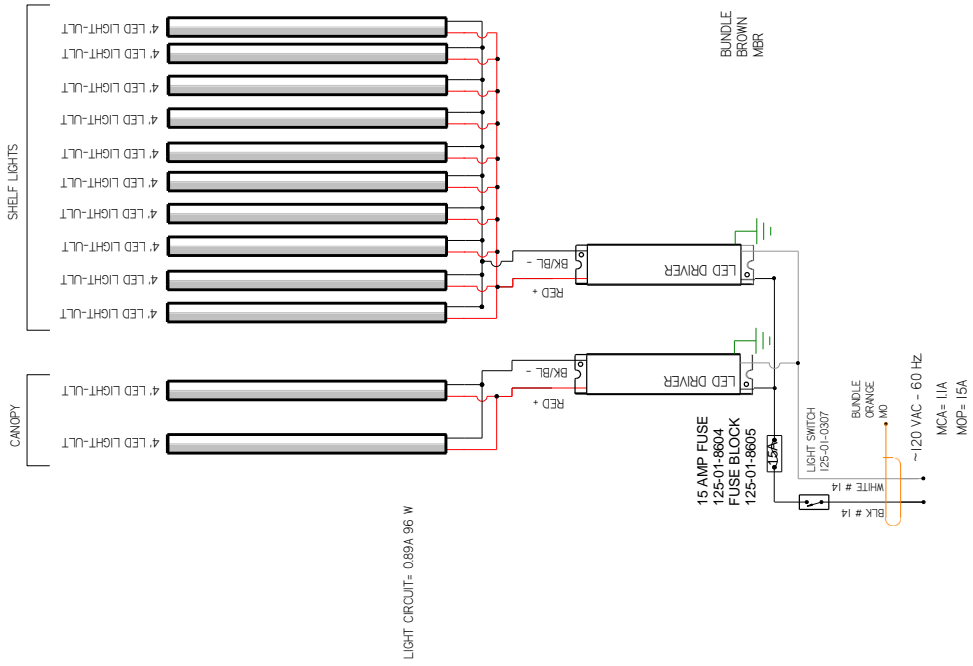

LIGHT CIRCUIT= 089A 96 W

EVP FAN MOTOR
21 3172579
12W 0.24A @ 120VAC

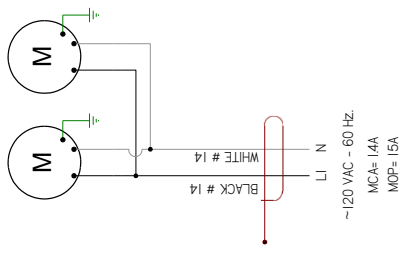

COND. PUMPS BECKETT™
CB151ULTZ 225-01-1661
17A @120VAC

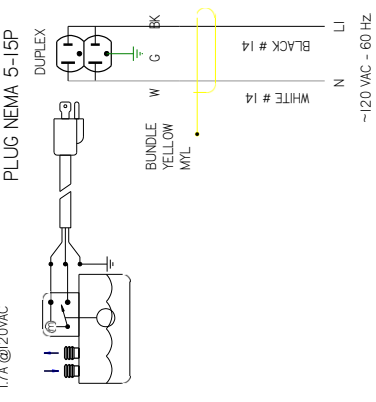

HUSSMANN
DIAGRAM-24-72-8-S
C

FACTORY 14GA WIRE
_FACTORY 10GA WIRE
--- FIELD WIRE ---
DO NOT SCALE DRAWING
SHEET 1 OF 3

UL COLOR CODES / ABBREVIATIONS
 RED = RD
 BLACK = BK
 BLUE = BL
 YELLOW = YL
 GRAY = GR
 WHITE = WT
 GREEN = GN
 BROWN = BN
 ORANGE = OR
 OR VIOLET = VT

3127783
C

- NOTES:
1. PRINTED DOCUMENT REQUIRED SETTING: ALL COLORS BLACK & WHITE
 2. CASE & ANY REMOVABLE PANEL WITH ELECTRICAL PARTS MUST BE GROUNDED.
 3. WHEN PASSING WIRES THROUGH METAL HOLES A GROMMET MUST BE USED

CIRCUIT #2

LOADING	
208	240-V
L1	17.3 20.0
L2	17.3 20.0

SENSOR EKC-202C
DANFOSS® # 084N0027
IH26193500

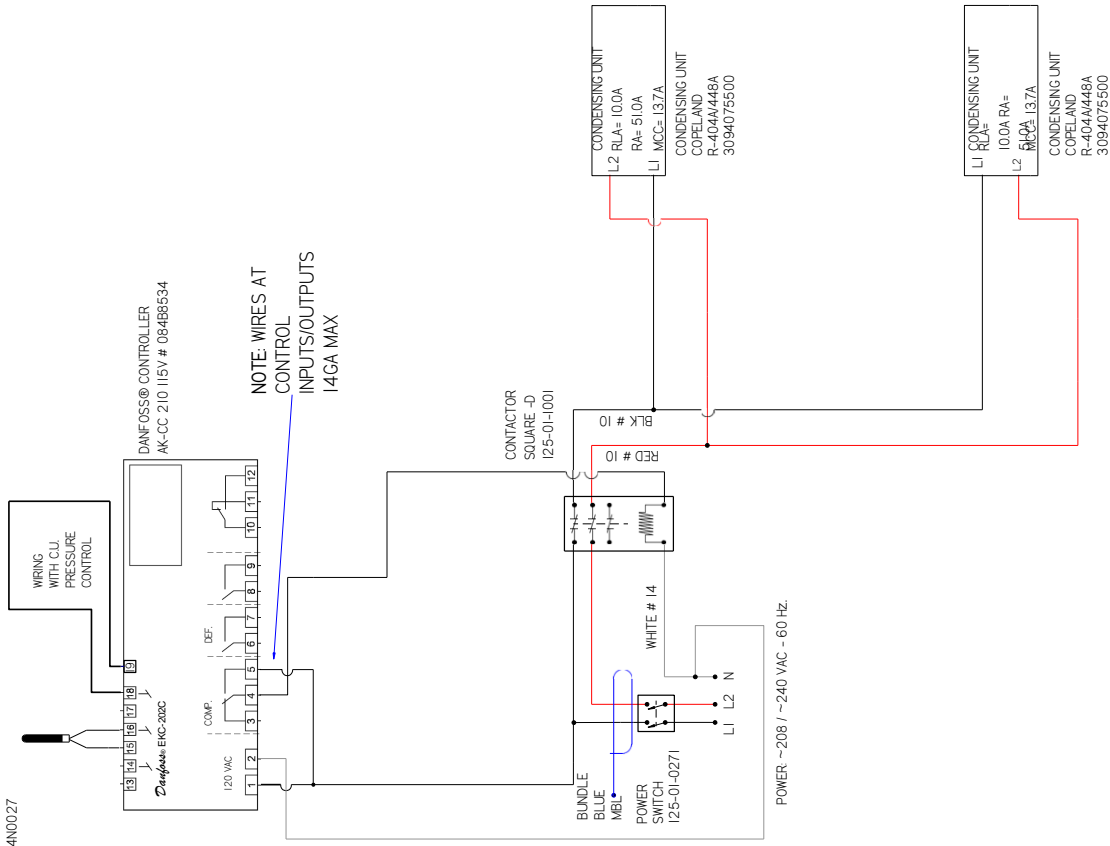

NOTE: WIRES AT
CONTROL
INPUTS/OUTPUTS
14GA MAX

UL COLOR CODES / ABBREVIATIONS

RED = RD	WHITE = WT
BLACK = BK	GREEN = GN
BLUE = BL	BROWN = BN
YELLOW = YL	ORANGE = OR
YL GRAY = YL GRAY	OR VIOLET = OR VIOLET
	VT

FACTORY 14GA WIRE

FACTORY 10GA WIRE
FIELD WIRE

DO NOT SCALE DRAWING
SHEET 2 OF 3

HUSSMANN
DIAGRAM-24-72-8-S
C
3127783
C

- NOTES:
1. PRINTED DOCUMENT REQUIRED SETTING. ALL COLORS BLACK & WHITE
 2. CASE & ANY REMOVABLE PANEL WITH ELECTRICAL PARTS MUST BE GROUNDED.
 3. WHEN PASSING WIRES THROUGH METAL HOLES A GROMMET MUST BE USED

CIRCUIT #3

LOADING	
208	240 V
L1	10.8
L2	12.5
	12.5

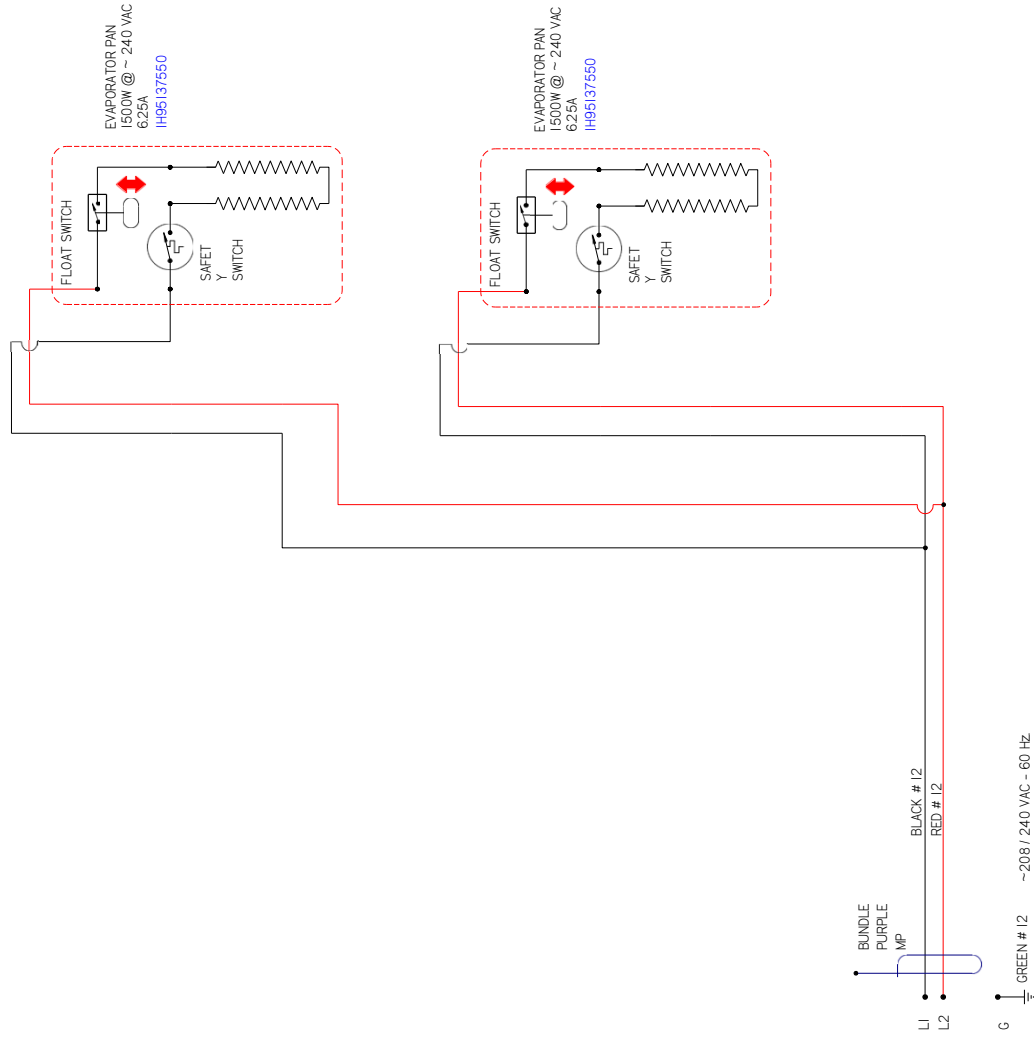

- NOTES:
1. PRINTED DOCUMENT REQUIRED SETTING: ALL COLORS BLACK & WHITE
 2. CASE & ANY REMOVABLE PANEL WITH ELECTRICAL PARTS MUST BE GROUNDED.
 3. WHEN PASSING WIRES THROUGH METAL HOLES A GROMMET MUST BE USED

HUSSMANN	
DIAGRAM-24-72-8-S	
C	
FACTORY 14GA WIRE	DO NOT SCALE DRAWING
FACTORY LOGA WIRE	SHEET 3 OF 3
FIELD WIRE	
UL COLOR CODES / ABBREVIATIONS	
RED = RD	WHITE = WT
BLACK = BK	GREEN = GN
BLUE = BL	BROWN = BN
YELLOW = YL	ORANGE = OR
GRAY = GR	VIOLET = VT

3127783

C

CIRCUIT #1

LOADING	
120 V	
L1 3-6	

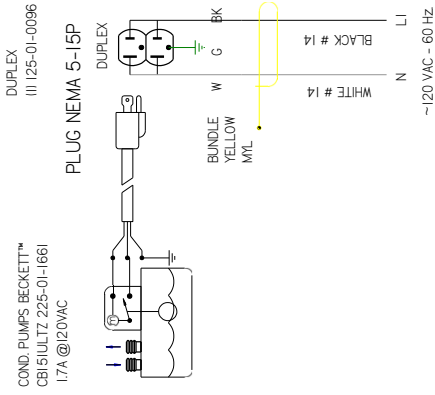
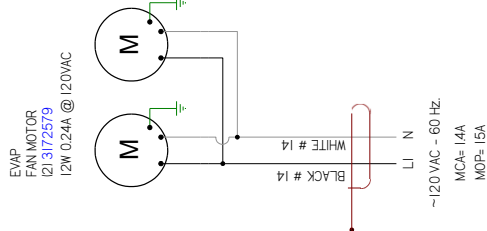
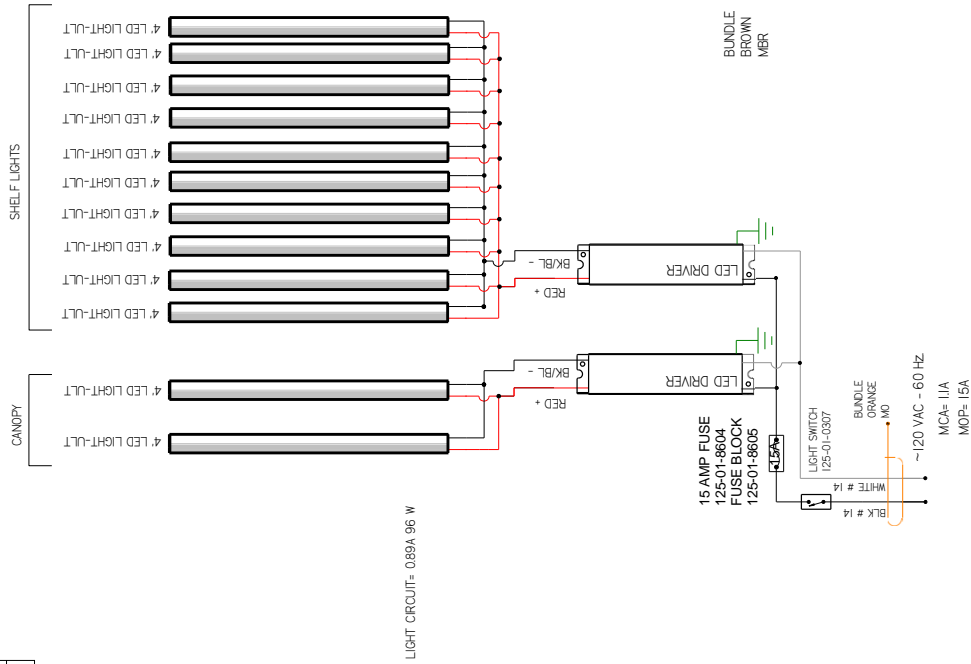

REVISION HISTORY			
REV	ECN	DATE	REVISION DESCRIPTION
B	ECN-C00-0014513	12-3-21	NEW LIGHTS
C	ECN-C00-0018013	1-4-24	CHANGED FAN MOTORS

REVISION HISTORY			
REV	CHKD BY	APPR BY	
B	CB	CB	CB
C	CB	CB	CB

HUSSMANN
DIAGRAM-RGD-30-7
2-8-SC

FACTORY 14GA WIRE
 _FACTORY 10GA WIRE
 --- FIELD WIRE
 --- DO NOT SCALE DRAWING

UL COLOR CODES / ABBREVIATIONS
 RED = RD
 BLACK = BK
 BLUE = BL
 YELLOW = YL
 GRAY = GR
 WHITE = WT
 GREEN = GN
 BROWN = BN
 ORANGE = OR
 VIOLET = VT

DO NOT SCALE DRAWING
 SHEET 1 OF 3

3127784
 183

- NOTES:
1. PRINTED DOCUMENT REQUIRED SETTING: ALL COLORS BLACK & WHITE
 2. CASE & ANY REMOVABLE PANEL WITH ELECTRICAL PARTS MUST BE GROUNDED.
 3. WHEN PASSING WIRES THROUGH METAL HOLES A GROMMET MUST BE USED

CIRCUIT #2

LOADING	
208	240 V
L1	17.3 20.0
L2	17.3 20.0

SENSOR EKC-202C
DANFOSS® # 084N0027
IH26193500

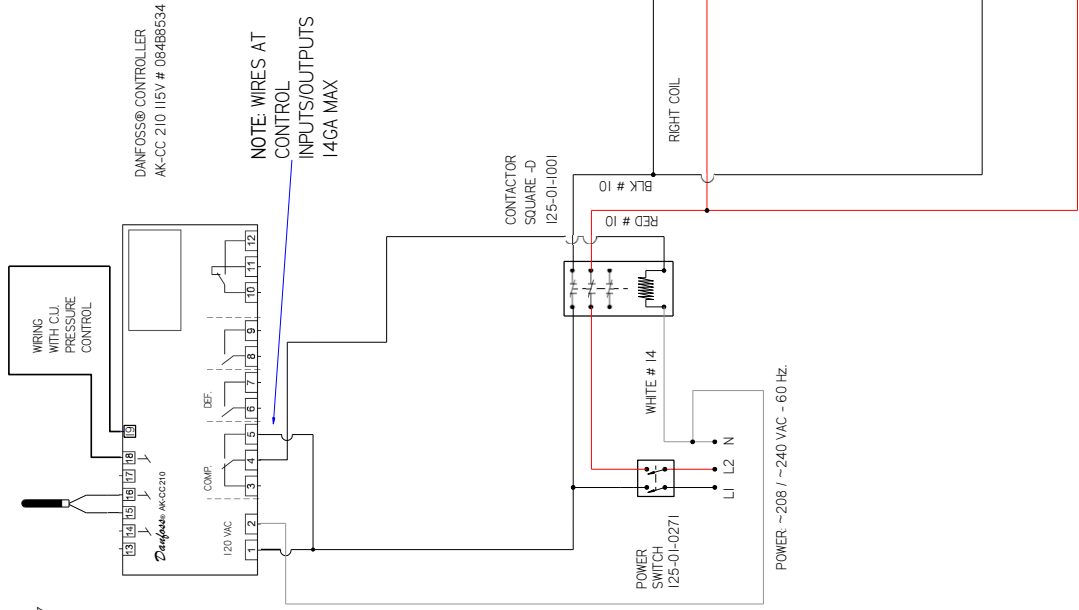

- NOTES:
1. PRINTED DOCUMENT REQUIRED SETTING: ALL COLORS BLACK & WHITE
 2. CASE & ANY REMOVABLE PANEL WITH ELECTRICAL PARTS MUST BE GROUNDED.
 3. WHEN PASSING WIRES THROUGH METAL HOLES A GROMMET MUST BE USED

HUSSMANN®
DIAGRAM-RGD-30-7
2-8-SC

FACTORY 14GA WIRE
_FACTORY 10GA WIRE
--- FIELD WIRE ---
DO NOT SCALE DRAWING
SHEET 2 OF 3

UL COLOR CODES / ABBREVIATIONS

RED = RD	WHITE = WT
BLACK = BK	GREEN = GN
BLUE = BL	BROWN = BN
YELLOW = YL	ORANGE = OR
GRAY = GR	OR VIOLET = VT

CIRCUIT #3

	LOADING
	208 240 V
L1	108 12.5
L2	√108 12.5

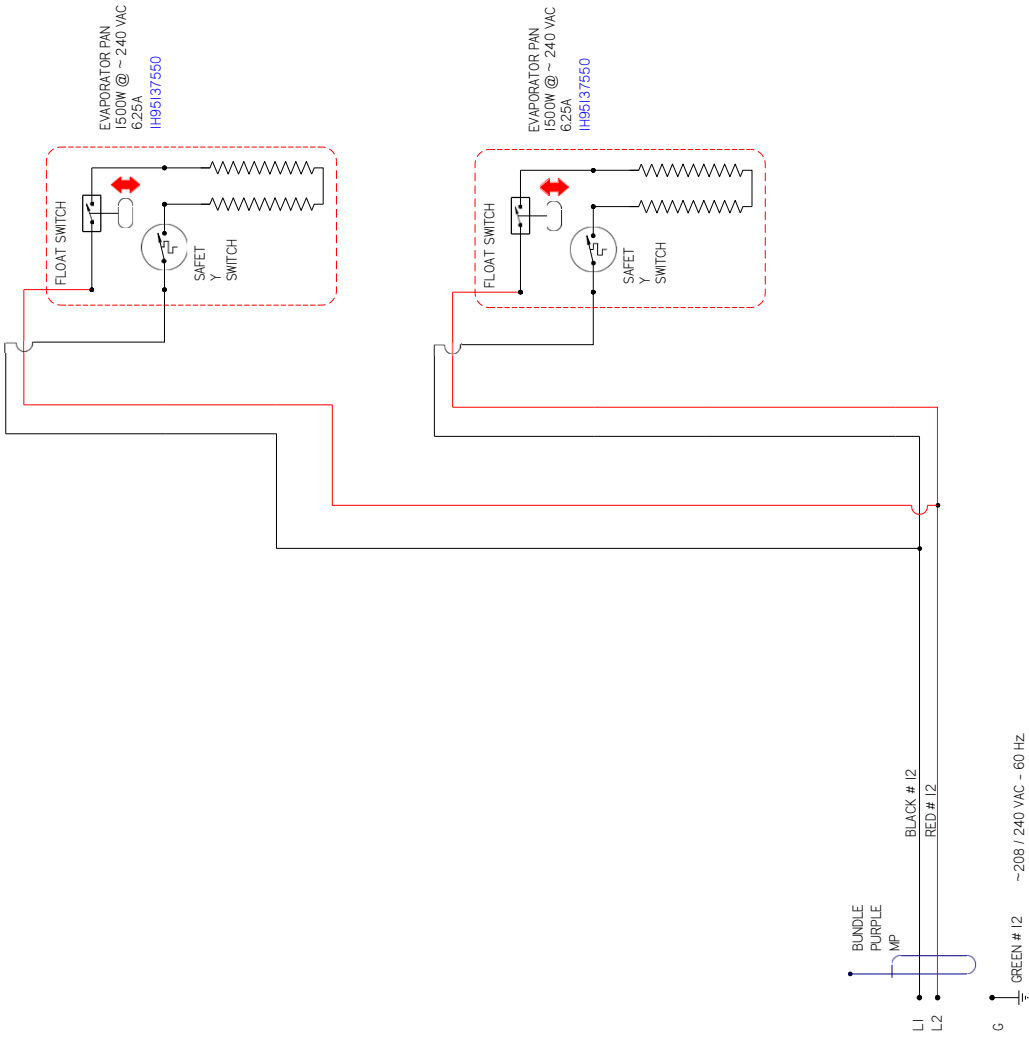

UL COLOR CODES / ABBREVIATIONS

RED = RD	WHITE = WT
BLACK = BK	GREEN = GN
BLUE = BL	BROWN = BN
YELLOW = YL	ORANGE = OR
GRAY = GR	OR VIOLET = VT

FACTORY 14GA WIRE

FACTORY LOGA WIRE
FIELD WIRE
DO NOT SCALE DRAWING
SHEET 3 OF 3

HUSSMANN
DIAGRAM-RGD-30-7
2-8-SC
3127784

- NOTES:
1. PRINTED DOCUMENT REQUIRED SETTING. ALL COLORS BLACK & WHITE
 2. CASE & ANY REMOVABLE PANEL WITH ELECTRICAL PARTS MUST BE GROUNDED.
 3. WHEN PASSING WIRES THROUGH METAL HOLES A GROMMET MUST BE USED

CIRCUIT #1
LOADING 83" HIGH

120V			
120V			
120V			
120V			

CIRCUIT #1
LOADING 72" HIGH

120V			
120V			
120V			
120V			

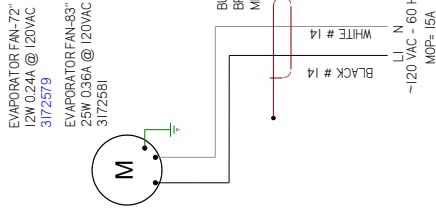
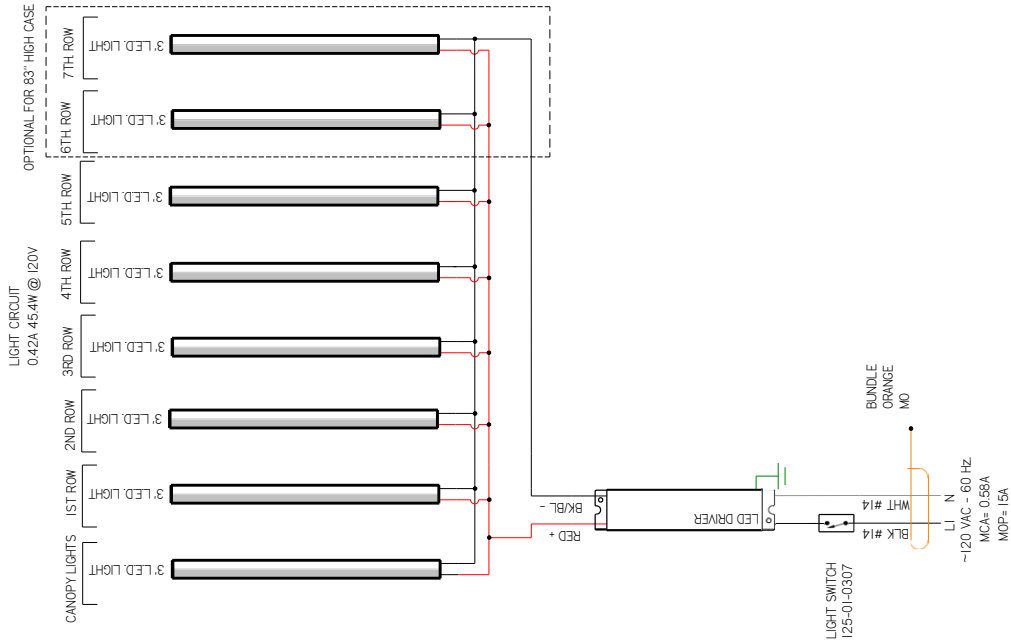

EVAPORATOR FAN-72"
12W 0.24A @ 120VAC
3172579

EVAPORATOR FAN-83"
25W 0.36A @ 120VAC
3172581

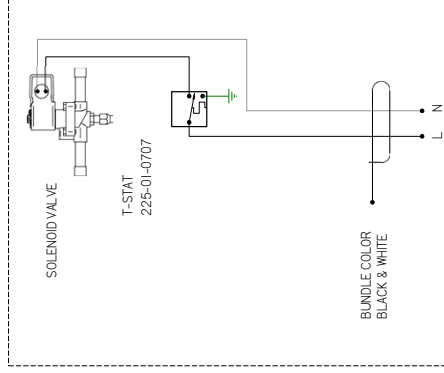

BUNDLE COLOR
BLACK & WHITE

MATERIAL - NA

DATE DRAWN - 8-10-16

DRAWN BY - CRAIG BOOREY

REVIEWED BY - CRAIG BOOREY

APPROVED BY - CRAIG BOOREY

UNLESS OTHERWISE SPECIFIED DIMENSIONS ARE IN INCHES

TOLERANCES ARE:

DECIMALS .XX +0.3 .XXX +0.10

ANGLES ± 2°

PROJECTION

HUSSMANN

RGD-39-R 24 & 30

X 72, 24 & 30 X 83

3013101

C

REV. BY

CHG. BY

APPR. BY

DATE

REVISION DESCRIPTION

REV. BY

CHG. BY

APPR. BY

DATE

REVISION DESCRIPTION

REV. BY

CHG. BY

APPR. BY

DATE

REVISION DESCRIPTION

REV. BY

CHG. BY

APPR. BY

DATE

REVISION DESCRIPTION

REV. BY

CHG. BY

APPR. BY

DATE

REVISION DESCRIPTION

REV. BY

CHG. BY

APPR. BY

DATE

REVISION DESCRIPTION

REV. BY

CHG. BY

APPR. BY

DATE

REVISION DESCRIPTION

REV. BY

CHG. BY

APPR. BY

DATE

REVISION DESCRIPTION

REV. BY

CHG. BY

APPR. BY

DATE

REVISION DESCRIPTION

REV. BY

CHG. BY

APPR. BY

DATE

REVISION DESCRIPTION

REV. BY

CHG. BY

APPR. BY

DATE

REVISION DESCRIPTION

REV. BY

CHG. BY

APPR. BY

DATE

REVISION DESCRIPTION

REV. BY

CHG. BY

APPR. BY

DATE

REVISION DESCRIPTION

REV. BY

CHG. BY

APPR. BY

DATE

REVISION DESCRIPTION

REV. BY

CHG. BY

APPR. BY

DATE

REVISION DESCRIPTION

REV. BY

CHG. BY

APPR. BY

DATE

REVISION DESCRIPTION

REV. BY

CHG. BY

APPR. BY

DATE

REVISION DESCRIPTION

REV. BY

CHG. BY

APPR. BY

DATE

REVISION DESCRIPTION

REV. BY

CHG. BY

APPR. BY

DATE

REVISION DESCRIPTION

REV. BY

CHG. BY

APPR. BY

DATE

REVISION DESCRIPTION

REV. BY

CHG. BY

APPR. BY

DATE

REVISION DESCRIPTION

REV. BY

CHG. BY

APPR. BY

DATE

REVISION DESCRIPTION

REV. BY

CHG. BY

APPR. BY

DATE

REVISION DESCRIPTION

REV. BY

CHG. BY

APPR. BY

DATE

REVISION DESCRIPTION

REV. BY

CHG. BY

APPR. BY

DATE

REVISION DESCRIPTION

REV. BY

CHG. BY

APPR. BY

DATE

REVISION DESCRIPTION

REV. BY

CHG. BY

APPR. BY

DATE

REVISION DESCRIPTION

REV. BY

CHG. BY

APPR. BY

DATE

REVISION DESCRIPTION

REV. BY

CHG. BY

APPR. BY

DATE

REVISION DESCRIPTION

REV. BY

CHG. BY

APPR. BY

DATE

REVISION DESCRIPTION

REV. BY

CHG. BY

APPR. BY

DATE

REVISION DESCRIPTION

REV. BY

CHG. BY

APPR. BY

DATE

REVISION DESCRIPTION

REV. BY

CHG. BY

APPR. BY

DATE

REVISION DESCRIPTION

REV. BY

CHG. BY

APPR. BY

DATE

REVISION DESCRIPTION

REV. BY

CHG. BY

APPR. BY

DATE

REVISION DESCRIPTION

REV. BY

CHG. BY

APPR. BY

DATE

REVISION DESCRIPTION

REV. BY

CHG. BY

APPR. BY

DATE

REVISION DESCRIPTION

REV. BY

CHG. BY

APPR. BY

DATE

REVISION DESCRIPTION

REV. BY

CHG. BY

APPR. BY

DATE

REVISION DESCRIPTION

REV. BY

CHG. BY

APPR. BY

DATE

REVISION DESCRIPTION

REV. BY

CHG. BY

APPR. BY

DATE

REVISION DESCRIPTION

REV. BY

CHG. BY

APPR. BY

DATE

REVISION DESCRIPTION

REV. BY

CHG. BY

APPR. BY

DATE

REVISION DESCRIPTION

REV. BY

CHG. BY

APPR. BY

DATE

REVISION DESCRIPTION

REV. BY

CHG. BY

APPR. BY

DATE

REVISION DESCRIPTION

REV. BY

CHG. BY

APPR. BY

DATE

REVISION DESCRIPTION

REV. BY

CHG. BY

APPR. BY

DATE

REVISION DESCRIPTION

REV. BY

CHG. BY

APPR. BY

DATE

REVISION DESCRIPTION

REV. BY

CHG. BY

APPR. BY

DATE

REVISION DESCRIPTION

REV. BY

CHG. BY

APPR. BY

DATE

REVISION DESCRIPTION

REV. BY

CHG. BY

APPR. BY

DATE

REVISION DESCRIPTION

REV. BY

CHG. BY

APPR. BY

DATE

REVISION DESCRIPTION

CIRCUIT #1
LOADING 83" HIGH

120V			
120V			
120V			
120V			

CIRCUIT #1
LOADING 72" HIGH

120V			
120V			
120V			
120V			

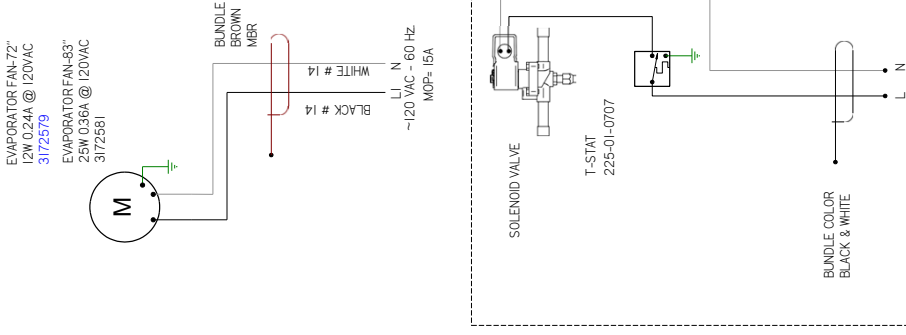
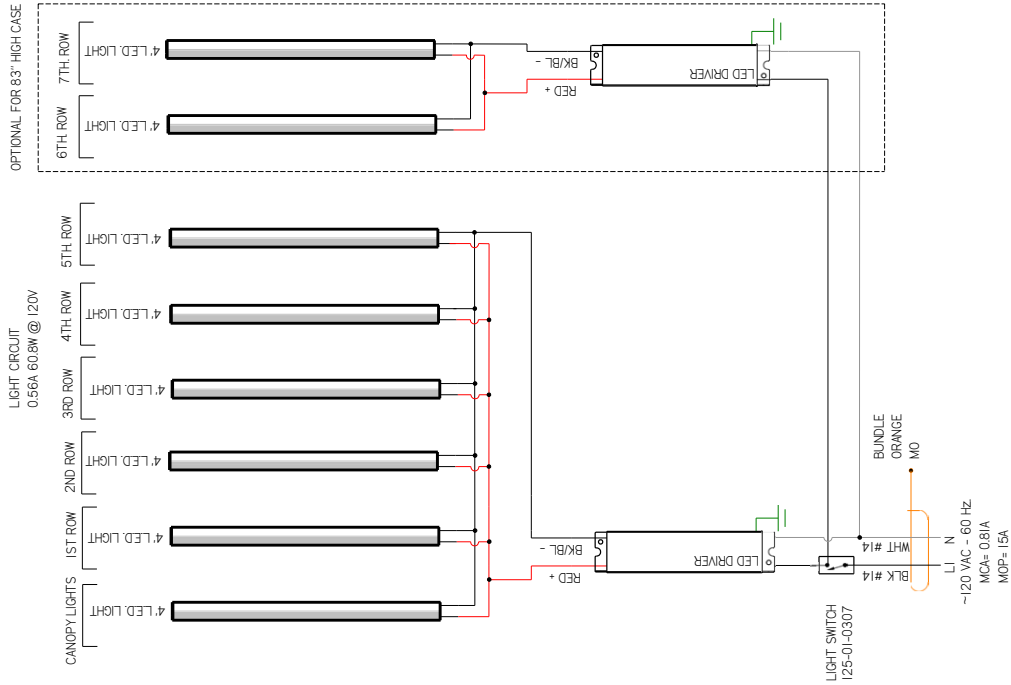

REV	EN	DATE	REVISION DESCRIPTION	REV BY	CHKD BY	APPR BY
A	ECN-CAP-0003545	2016/09/10	RELEASED TO PRODUCTION	CB	CB	CB
B	ECN-COD-0014611	2020/11/23	NEW LIGHTS	CB	CB	CB
C	ECN-COD-0086013	2024/01/03	CHANGED FAN MOTORS	CB	CB	CB

EVAPORATOR FAN-72"
12W 0.24A @ 120VAC
3172579

EVAPORATOR FAN-83"
25W 0.36A @ 120VAC
3172581

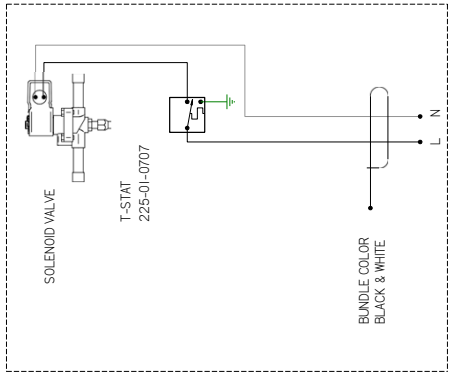

HUSSMANN
RGD-4-R 24 X 30 X
72, 24 & 30 X 83

MATERIAL - NA
DATE DRAWN - 8-10-16
DRAWN BY - CRAIG BOOREY
REVIEWED BY - CRAIG BOOREY
APPROVED BY - CRAIG BOOREY
UNLESS OTHERWISE SPECIFIED DIMENSIONS ARE IN INCHES
TOLERANCES ARE:
DECIMALS .XX +0.3 .XXX +0.10
ANGLES ± 2°

ECN-CAP-0003545
REF -
SHEET 1 OF 1
THIRD ANGLE PROJECTION

3013100 | C

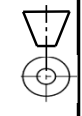

NOTES:
CASE MUST BE GROUNDED
WHEN PASSING WIRES THROUGH METAL HOLES A GROMMET MUST BE USED

CIRCUIT #1
LOADING 83" HIGH

120V			
L1	L2		

CIRCUIT #1
LOADING 72" HIGH

120V			
L1	L2		

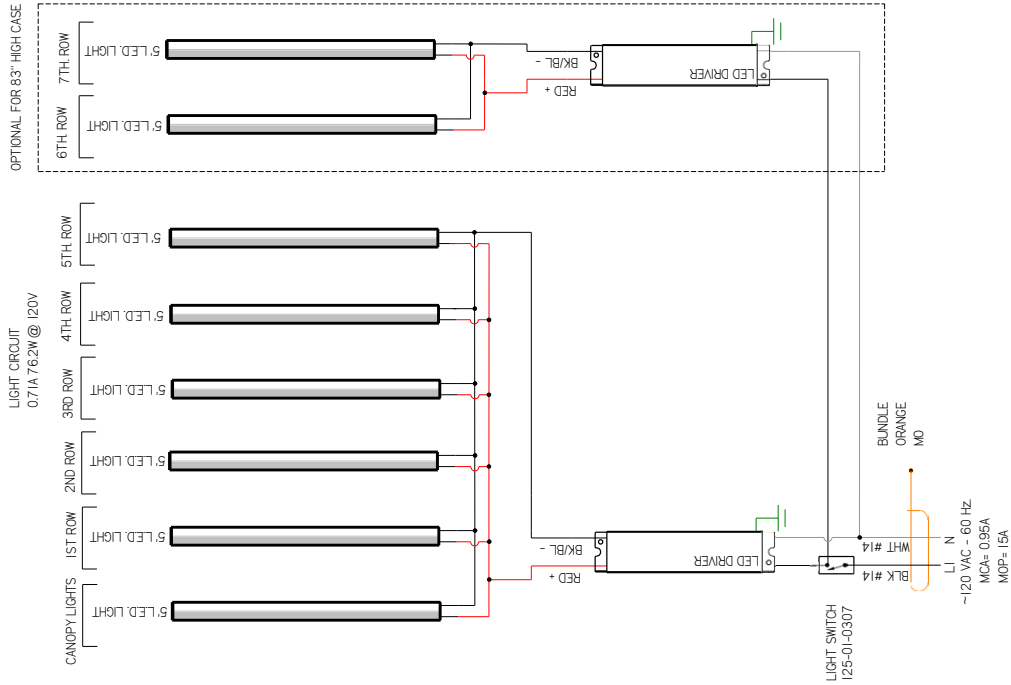

REV	EN	DATE	REVISION DESCRIPTION	REV BY	CHK BY	APPR BY
A	ECN-CAP-0003545	2016/09/10	RELEASED TO PRODUCTION	CB	CB	CB
B	ECN-COD-0014611	2020/01/23	NEW LIGHTS	CB	CB	CB
C	ECN-COD-0008003	2024/01/03	CHANGED FAN MOTORS	CB	CB	CB

EVAPORATOR FAN-83"
25W 0.36A @ 120VAC
(2) 3172581

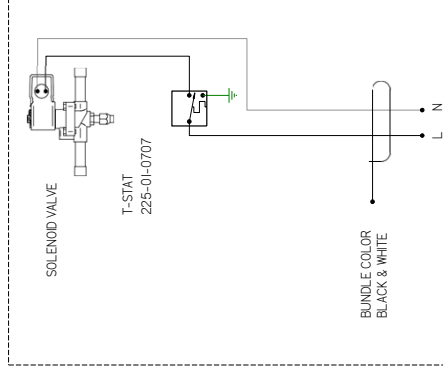
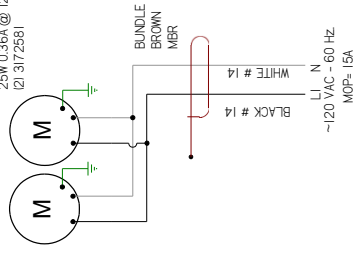

HUSSMANN
RGD-5-R 24 & 30 X
72, 24 & 30 X 83

MATERIAL - NA
 DATE DRAWN - 8-10-16
 DRAWN BY - CRAIG BOOREY
 REVIEWED BY - CRAIG BOOREY
 APPROVED BY - CRAIG BOOREY
 UNLESS OTHERWISE SPECIFIED DIMENSIONS ARE IN INCHES
 TOLERANCES ARE:
 DECIMALS .XX +0.3 .XXX +0.10
 ANGLES ± 2°

ECN-CAP-0003545
 REF -
 SHEET 1 OF 1

3013099 | C

PROJECTION

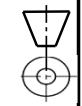

NOTES:
CASE MUST BE GROUNDED
WHEN PASSING WIRES THROUGH METAL HOLES A GROMMET MUST BE USED

CIRCUIT #1
LOADING 83" HIGH

120V			
110			

CIRCUIT #1
LOADING 72" HIGH

120V			
114			

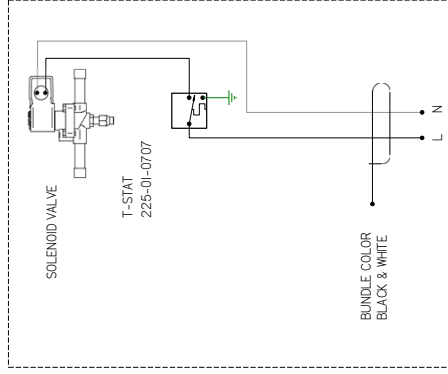
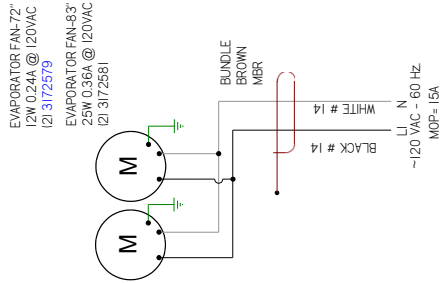
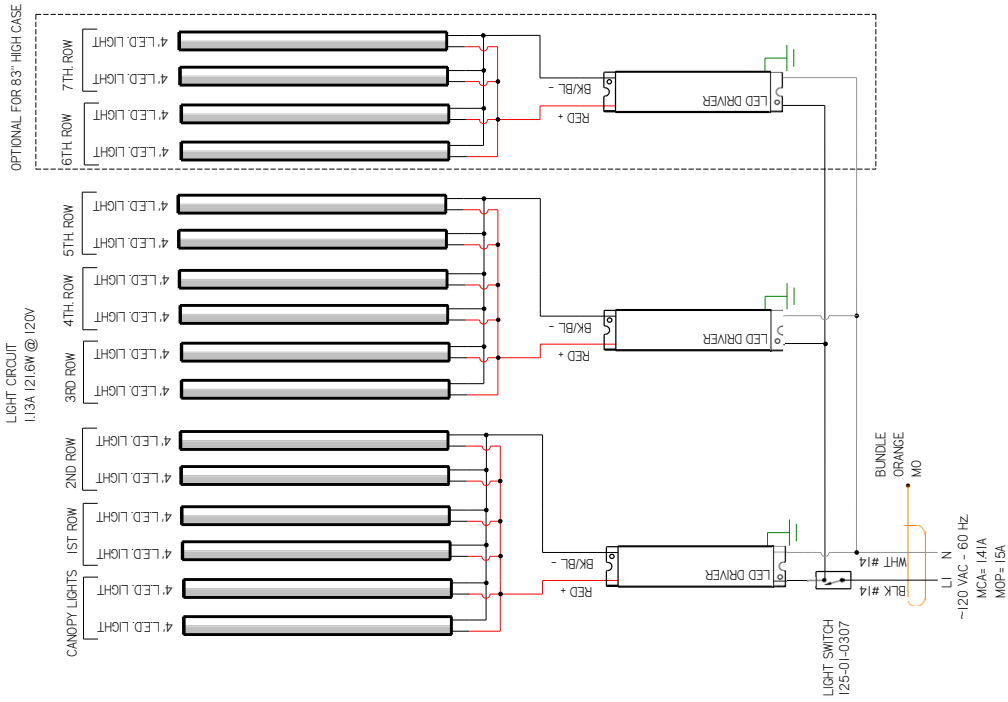

REV	EN	DATE	REVISION DESCRIPTION	REV BY	CHKD BY	APPR BY
A	ECN-CAP-0003545	2016/09/10	RELEASED TO PRODUCTION	CB	CB	CB
B	ECN-COD-0014611	2020/01/24	NEW LIGHTS	CB	CB	CB
C	ECN-COD-0009013	2024/01/03	CHANGED FAN MOTORS	CB	CB	CB

HUSSMANN
RGD-8-R 24 & 30 X
72, 24 & 30 X 83

MATERIAL - NA
DATE DRAWN - 8-10-16
DRAWN BY - CRAIG BOOREY
REVIEWED BY - CRAIG BOOREY
APPROVED BY - CRAIG BOOREY
UNLESS OTHERWISE SPECIFIED DIMENSIONS ARE IN INCHES
TOLERANCES ARE:
DECIMALS .XX +0.3 .XXX +0.10
ANGLES ± 2°

ECN-CAP-0003545
REF -
SHEET 1 OF 1
THIRD ANGLE PROJECTION

3013097 | C

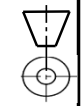

NOTES:
CASE MUST BE GROUNDED
WHEN PASSING WIRES THROUGH METAL HOLES A GROMMET MUST BE USED

CIRCUIT #1
LOADING 83" HIGH

120V			
15			
20			

CIRCUIT #1
LOADING 72" HIGH

120V			
15			
20			

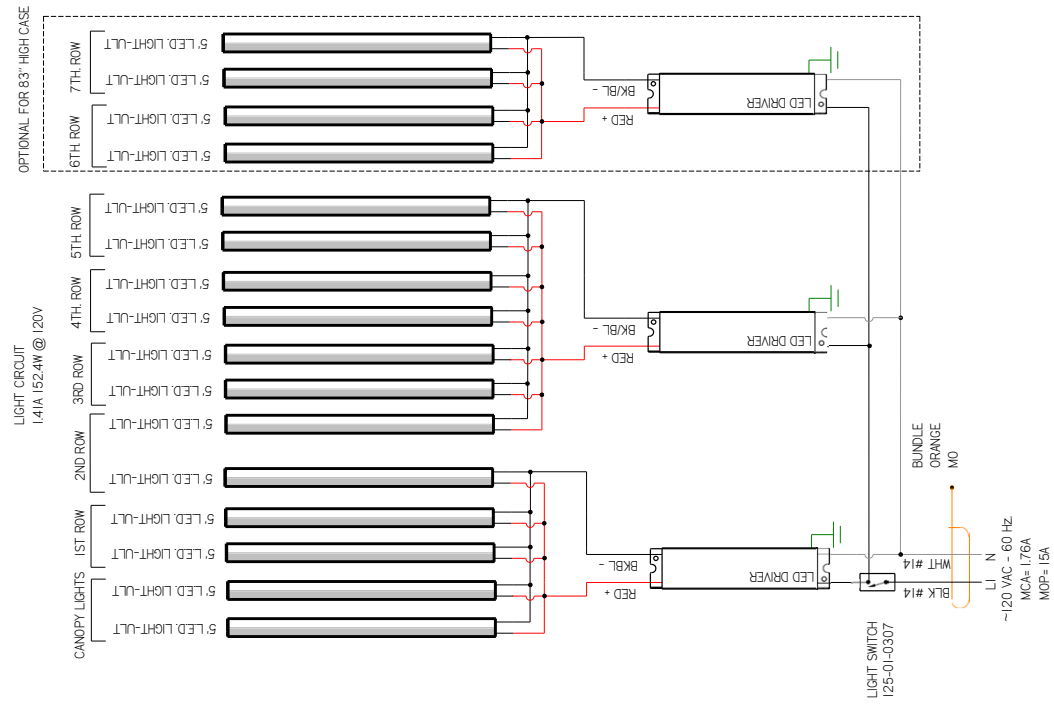

REVISION HISTORY

REV	EN	DATE	REVISION DESCRIPTION	REV BY	CHKD BY	APPR BY
A	ECN-CAP-0003648	2016/08/10	RELEASED TO PRODUCTION	CB	CB	CB
B	ECN-COD-0011347	2020/08/18	CHANGED LED DRIVER LAYOUT	CB	CB	CB
C	ECN-COD-0014612	2023/11/09	NEW LIGHTS	CB	CB	CB
D	ECN-COD-0018013	2024/01/03	CHANGED FAN MOTORS	CB	CB	CB

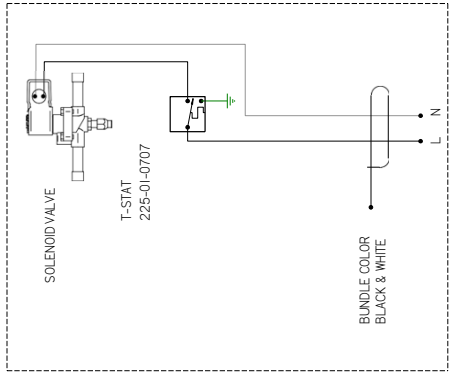
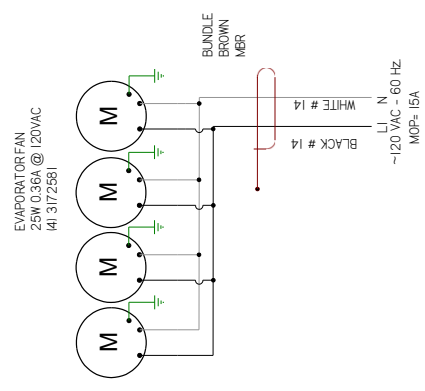

MATERIAL - N/A

DATE DRAWN - 8-10-16

DRAWN BY - CRAIG BOOREY

REVIEWED BY - CRAIG BOOREY

APPROVED BY - CRAIG BOOREY

UNLESS OTHERWISE SPECIFIED DIMENSIONS ARE IN INCHES

TOLERANCES ARE:

DECIMALS .XX +0.3 .XXX +0.10

ANGLES ± 2°

ECN-CAP-0003545

REF -

SHEET 1 OF 1

3013096

ANGU
E
PROJECTION

HUSSMANN
RGD-10-R 24 & 30 X
72, 24 & 30 X 83

NOTES:
CASE MUST BE GROUNDED
WHEN PASSING WIRES THROUGH METAL HOLES A GROMMET MUST BE USED

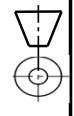

CIRCUIT #1
LOADING 83" HIGH

120V			
120V			
120V			
120V			

CIRCUIT #1
LOADING 72" HIGH

120V			
120V			
120V			
120V			

REV	EN	DATE	REVISION DESCRIPTION	REV BY	CHK BY	APP BY
A	ECN-CAP-0003545	20160910	RELEASED TO PRODUCTION	CB	CB	CB
B	ECN-COD-0014652	20201030	NEW LIGHTS	CB	CB	CB
C	ECN-COD-0008003	20240103	CHANGED FAN MOTORS	CB	CB	CB

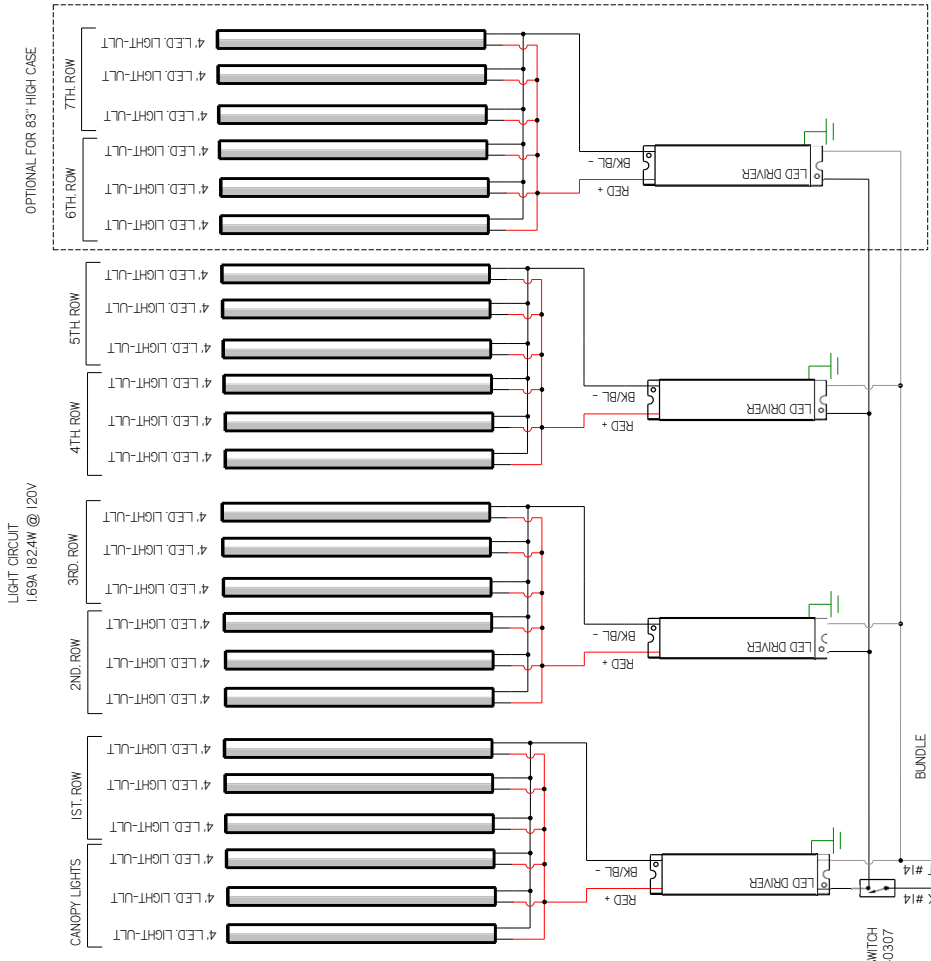

OPTIONAL FOR 83" HIGH CASE

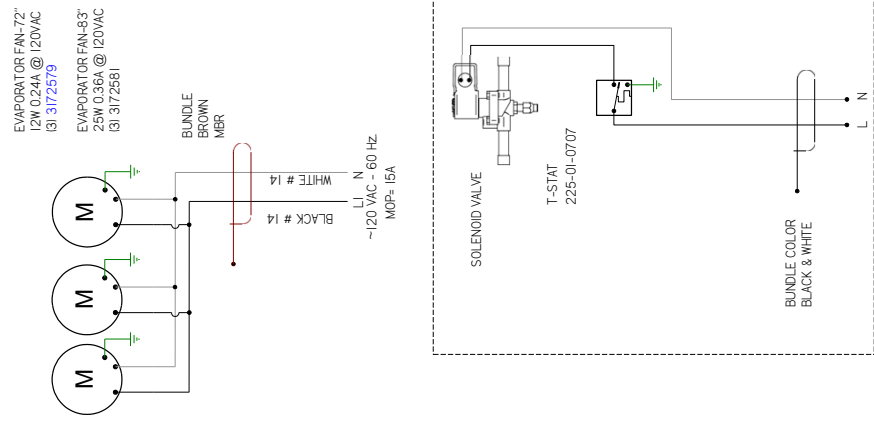

HUSSMANN
RGD-12-R 24 & 30 X
72, 24 & 30 X 83
 MATERIAL - NA
 DATE DRAWN - 8-10-16
 DRAWN BY - CRAIG BOOREY
 ECN-CAP-0003545
 REF -
 REVIEWED BY - CRAIG BOOREY
 SHEET NO. 1
 APPROVED BY - CRAIG BOOREY
 UNLESS OTHERWISE SPECIFIED DIMENSIONS ARE IN INCHES
 TO LEADING EDGE
 DECIMALS .XX +03 .XXX +010
 ANGLES ± 2°
 ANCL
 E
 PROJECTION
3013095 | **C**

NOTES:
 CASE MUST BE GROUNDED
 WHEN PASSING WIRES THROUGH METAL HOLES A GROMMET MUST BE USED

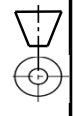

CIRCUIT #1
LOADING 83" HIGH

120V			
100			

CIRCUIT #1
LOADING 72" HIGH

120V			
100			

LIGHT CIRCUIT
0.53A 58W @ 120V

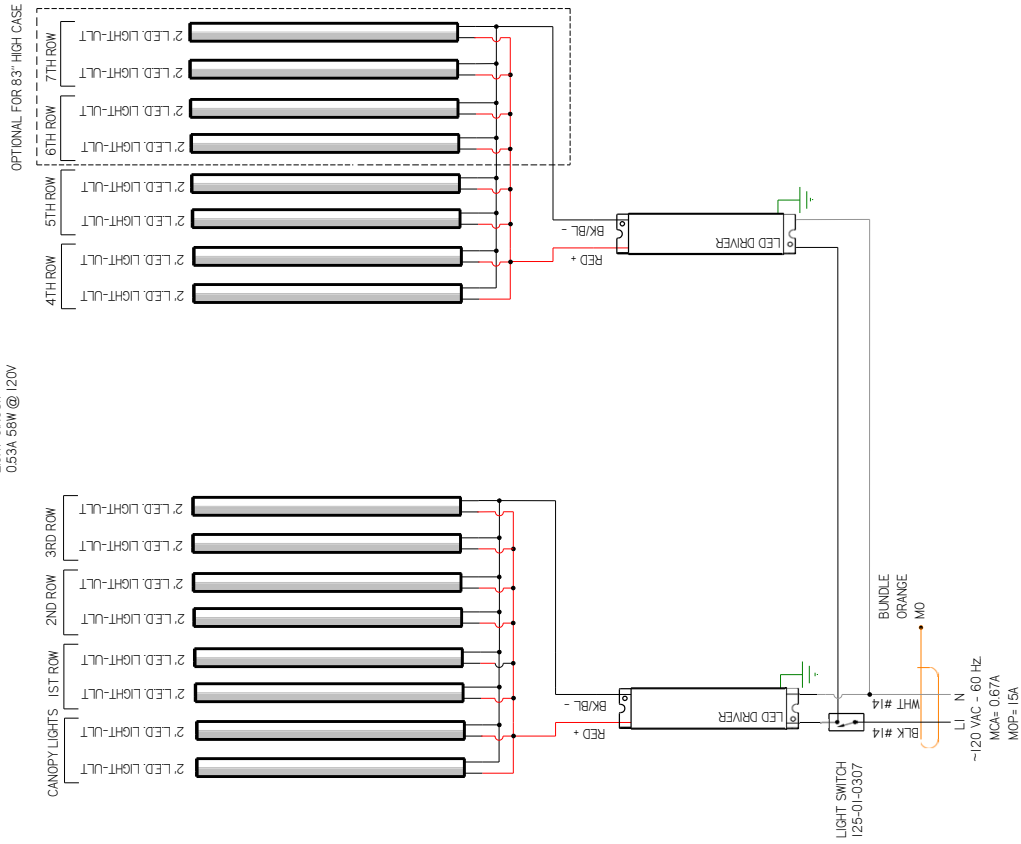

REV	EN	DATE	REVISION DESCRIPTION	REV BY	CHK BY	APP BY
A	ECN-CAP-0003545	2016/09/10	RELEASED TO PRODUCTION	CB	CB	CB
B	ECN-COD-0014612	2020/10/30	NEW LIGHTS	CB	CB	CB
C	ECN-COD-0008013	2024/01/03	CHANGED FAN MOTORS	CB	CB	CB

EVAPORATOR FAN-72"
12W 0.24A @ 120VAC
3172579

EVAPORATOR FAN-83"
25W 0.36A @ 120VAC
3172581

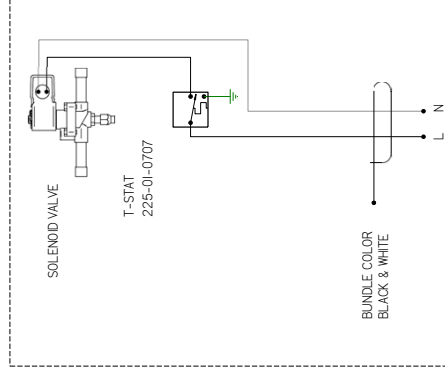
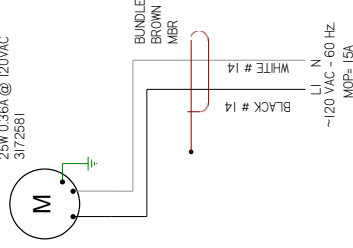

MATERIAL - NA

DATE DRAWN - 8-10-16

DRAWN BY - CRAIG BOOREY

REVIEWED BY - CRAIG BOOREY

APPROVED BY - CRAIG BOOREY

UNLESS OTHERWISE SPECIFIED DIMENSIONS ARE IN INCHES

TOLERANCES ARE:

THIRD DECIMALS .XX ±0.3 .XXX ±0.10

ANGLES ± 2°

HUSSMANN

RGDC-39-R 24 & 30

X 72, 24 & 30 X 83

REF -

SHEET 1 OF 1

PROJECTION

3013151

C

NOTES:
CASE MUST BE GROUNDED
WHEN PASSING WIRES THROUGH METAL HOLES A GROMMET MUST BE USED



REV	ECN	DATE	REVISION DESCRIPTION	REV BY	CHKD BY	APPR BY
D	ECN-COD-0016098	6-23-22	CHANGED RELAY	CB	CB	CB
E	ECN-COD-0019015	1-8-24	CHANGED FAN MOTOR	CB	CB	CB

CIRCUIT #1	LOADING
208	240 V
L1	15.2
L2	17.5
	15.3

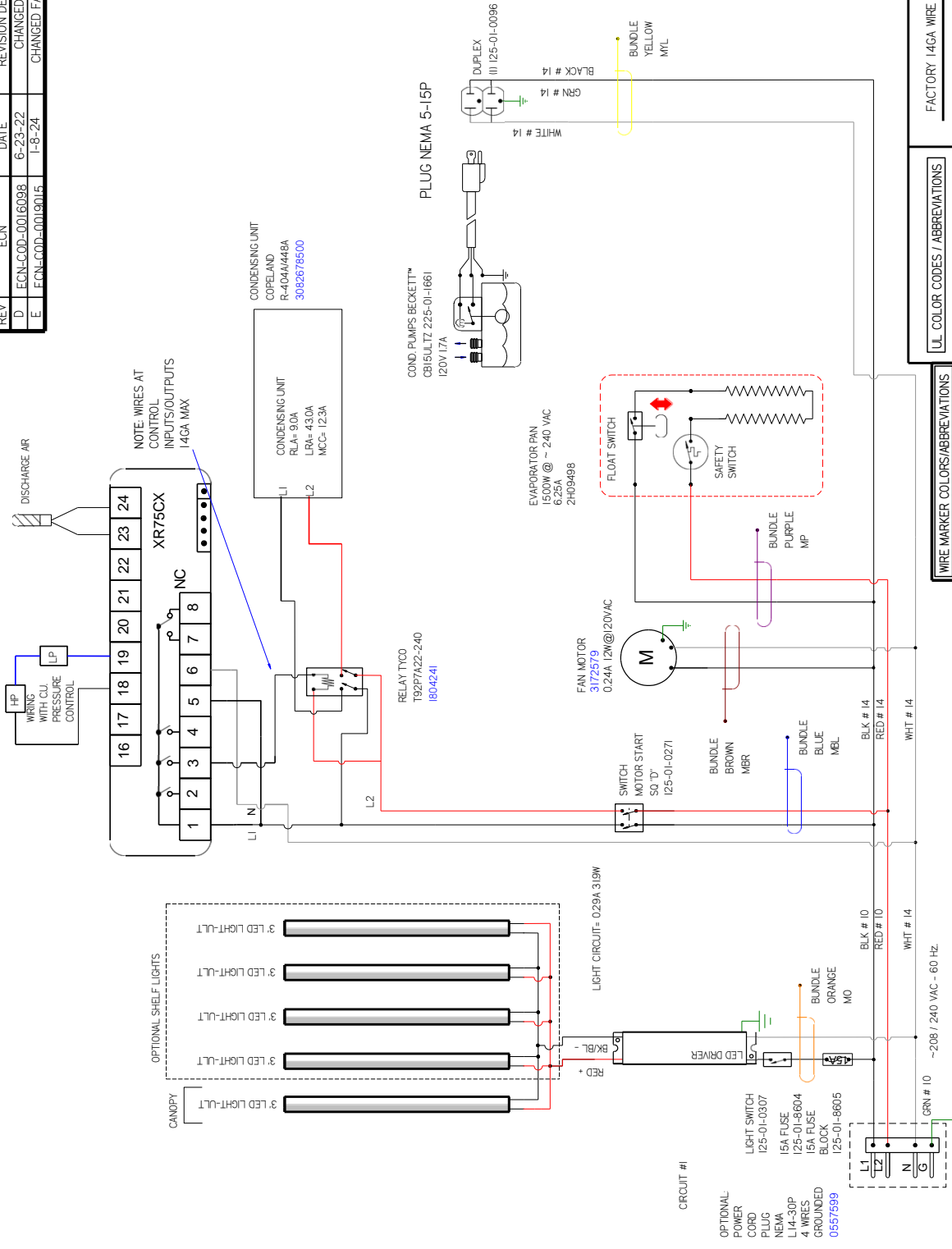

HUSSMANN
DIAGRAM-RGD-24-7
2-3-S XR75CX

FACTORY 14GA WIRE
 _FACTORY 10GA WIRE
 --- FIELD WIRE
 --- DO NOT SCALE DRAWING

UL COLOR CODES / ABBREVIATIONS:
 RED = RD
 BLACK = BK
 BLUE = BL
 BROWN = BRN
 YELLOW = YL
 YL GRAY = YL GRAY
 GRAY = GR

WIRE MARKER COLORS/ABBREVIATIONS:
 MAROON = MBR
 BLACK = MBK
 BLUE = MBL
 BROWN = MBR
 DARK BLUE = MDB
 GREEN = MG
 LIGHT BLUE = MLB
 WHITE = WT
 GREEN = GN
 BROWN = BN
 ORANGE = OR
 PURPLE = MP
 RED = MR
 YELLOW = MYL

DO NOT SCALE DRAWING
 SHEET 1 OF 1

NOTES:
 1. PRINTED DOCUMENT REQUIRED SETTING: ALL COLORS BLACK & WHITE
 2. CASE & ANY REMOVABLE PANEL WITH ELECTRICAL PARTS MUST BE GROUNDED.
 3. WHEN PASSING WIRES THROUGH METAL HOLES A GROMMET MUST BE USED

CIRCUIT #1
LOADING

208V	240
100	100
141	100
141	100

2

REV	ECN	DATE	REVISION DESCRIPTION	REV BY	CHKD BY	APPR BY
D	ECN-COD-0016096	6-23-22	CHANGED RELAY	CB	CB	CB
E	ECN-COD-0018015	1-8-24	CHANGED FAN MOTOR	CB	CB	CB

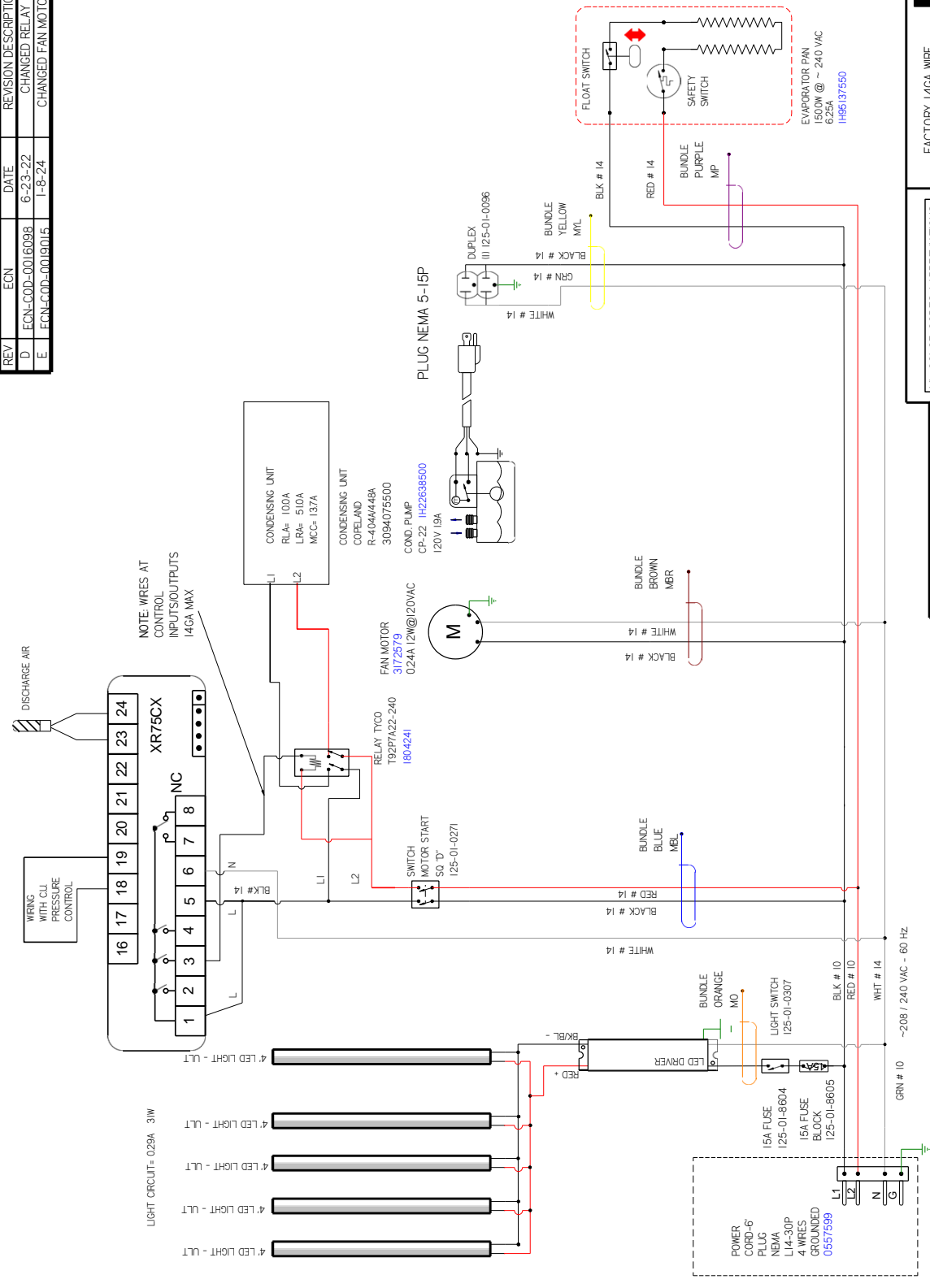

- NOTES:
1. PRINTED DOCUMENT REQUIRED SETTING: ALL COLORS BLACK & WHITE
 2. CASE & ANY REMOVABLE PANEL WITH ELECTRICAL PARTS MUST BE GROUNDED.
 3. WHEN PASSING WIRES THROUGH METAL HOLES A GROMMET MUST BE USED

HUSSMANN
DIAGRAM-RGD-24-7
2-4-S WXR75
CTLR
3157196
REV E

FACTORY 14GA WIRE
_FACTORY 10GA WIRE
--- FIELD WIRE ---
DO NOT SCALE DRAWING
SHEET 1 OF 1

CIRCUIT #1

	LOADING
208	240 V
L1	16.2 18.7
L2	14.1 16.3

REVISION HISTORY			
REV	ECN	DATE	REVISION DESCRIPTION
A	ECN-COD-0015289	5-3-22	RELEASED TO PRODUCTION
			REV BY (CHKD BY) APPR BY
			CB CB CB

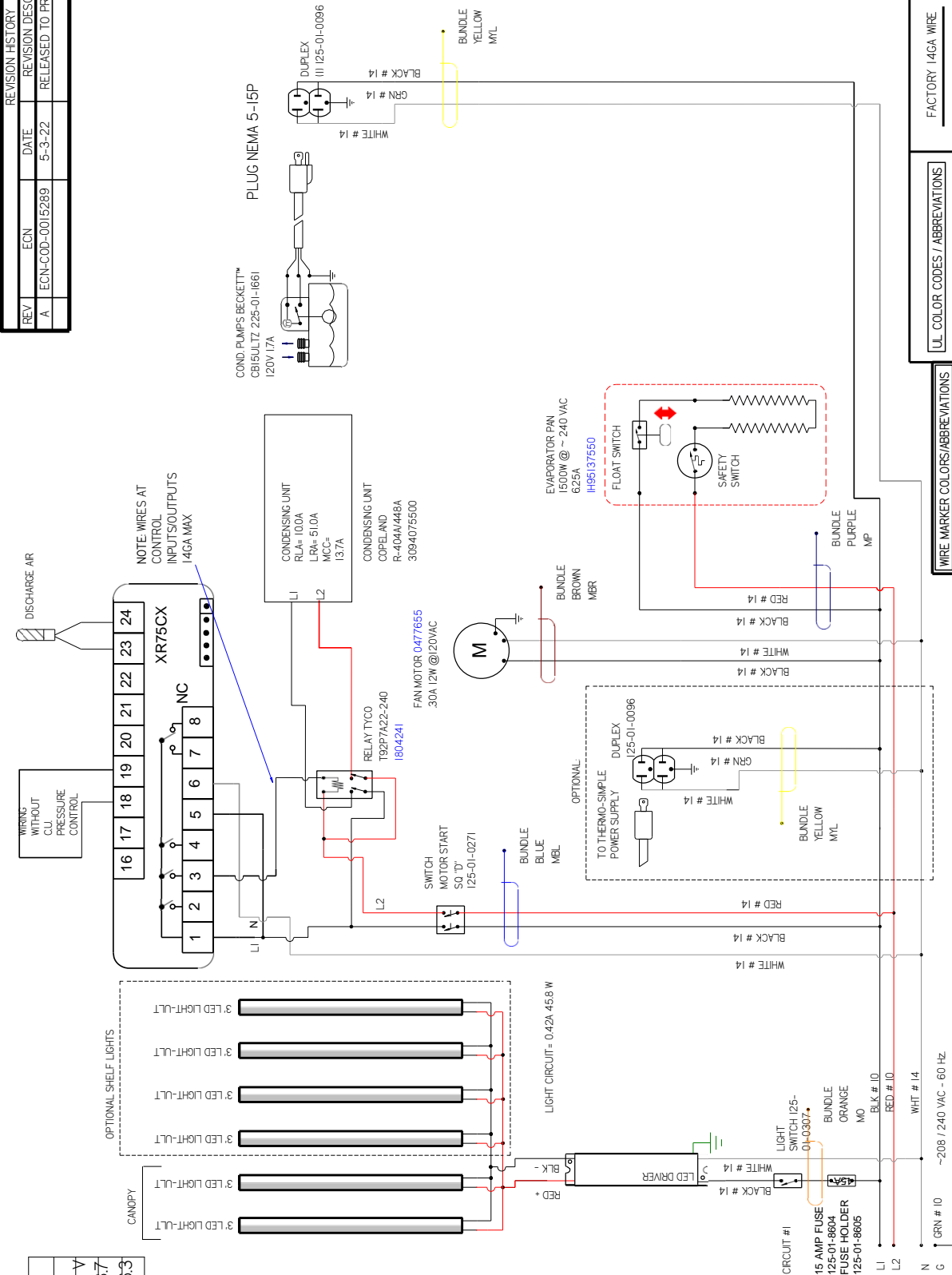

UL COLOR CODES / ABBREVIATIONS	
RED = RD	WHITE = WT
BLACK = BK	GREEN = GN
BLUE = BL	BROWN = BN
YELLOW = YL	ORANGE = OR
YL GRAY = GR	OR VIOLET = VT

WIRE MARKER COLORS/ABBREVIATIONS	
BLACK = MBK	MAROON = MR
BLUE = MBL	MMR ORANGE = MO
BROWN = MBR	MOPINK = MPI
DARK BLUE = MDB	PURPLE = MP
GREEN = MG	RED = MR
LIGHT BLUE = MLB	YELLOW = MYL

NOTES:
 1. PRINTED DOCUMENT REQUIRED SETTING: ALL COLORS BLACK & WHITE
 2. CASE & ANY REMOVABLE PANEL WITH ELECTRICAL PARTS MUST BE GROUNDED.
 3. WHEN PASSING WIRES THROUGH METAL HOLES A GROMMET MUST BE USED

HUSSMANN
 DIAGRAM-RGD-24-
 7 2-3'-9"-S WXR75
 CTLR

FACTORY 14GA WIRE
 -FACTORY 10GA WIRE
 -FIELD WIRE
 -DO NOT SCALE DRAWING

DO NOT SCALE DRAWING
 SHEET 1 OF 1

3165420

CIRCUIT #1

LOADING	
L1	208V/240 V
L2	18.9 21.8
	16.4 18.9

CANOPY LIGHTS

LIGHT CIRCUIT= .57A 614W

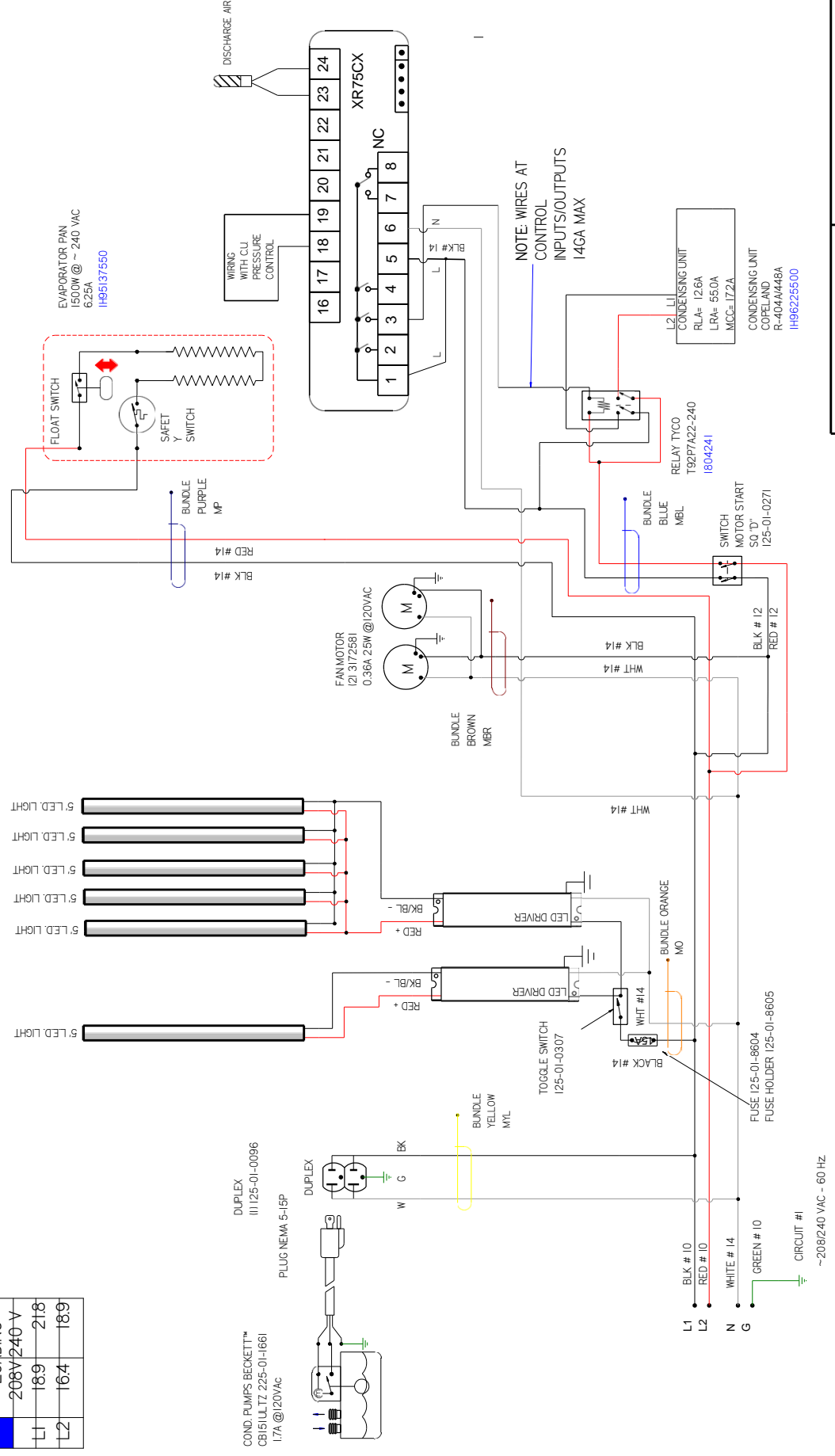

REVISION HISTORY

REV	ECN	DATE	REVISION DESCRIPTION	REV BY	CHKD BY	APPR BY
A	ECN-COD-001609Z	6-20-22	RELEASED TO PRODUCTION	CB	CB	CB
B	ECN-COD-0019015	1-8-24	CHANGED FAN MOTORS	CB	CB	CB

UL COLOR CODES / ABBREVIATIONS

RED = RD	WHITE = WT
BLACK = BK	GREEN = GN
BLUE = BL	BROWN = BN
YELLOW = YL	ORANGE = OR
GRAY = GR	OR VIOLET = OV

WIRE MARKER COLORS/ABBREVIATIONS

BLACK = MBK	MAROON = MR
BLUE = MBL	MMR ORANGE = MMR OR
BROWN = MBR	MO PINK = MPI
DARK BLUE = MDB	PURPLE = MP
GREEN = MG	RED = MR
LIGHT BLUE = MLB	YELLOW = MYL

NOTES:
 1. PRINTED DOCUMENT REQUIRED SETTING: ALL COLORS BLACK & WHITE
 2. CASE & ANY REMOVABLE PANEL WITH ELECTRICAL PARTS MUST BE GROUNDED.
 3. WHEN PASSING WIRES THROUGH METAL HOLES A GROMMET MUST BE USED

HUSSMANN
 DIAGRAM-RGD-24-7
 2-5-S WXR75
 CTRL
 3168017
 SHEET 1 OF 1

COND. PUMPS BECKETT™
 CB151ULZ 225-01-1661
 17A @20VAC

DUPLEX
 (11) 125-01-0096
 PLUG NEMA 5-15P

EVAPORATOR PAN
 1500W @ ~240 VAC
 625A
 IH95137560

WIRING WITH CU PRESSURE CONTROL

FAN MOTOR
 I21 3172581
 0.36A 25W @20VAC

LED DRIVER

TOGGLE SWITCH
 125-01-0307

RELAY TYCO
 T92P7A22-240
 I804241

CONDENSING UNIT
 RLA= 126A
 LRA= 550A
 MCC= 172A

CONDENSING UNIT
 COPPELLAND
 R-404A448A
 IH96225500

XR75CX

DISCHARGE AIR

NOTE: WIRES AT CONTROL INPUTS/OUTPUTS 14GA MAX

SWITCH MOTOR START
 SQ D1
 125-01-0271

FUSE 125-01-8604
 FUSE HOLDER 125-01-8605

~208/240 VAC - 60 HZ

CIRCUIT #1

LOADING	
120 V	
L1	3.1

REVISION HISTORY			
REV	ECN	DATE	REVISION DESCRIPTION
A	ECN-COD-001637Z	01-31-22	RELEASED TO PRODUCTION
B	ECN-COD-0016915	1-10-24	CHANGED FAN MOTOR

REV	CHKD BY	APPR BY
A	AL	CB
B	CB	CB

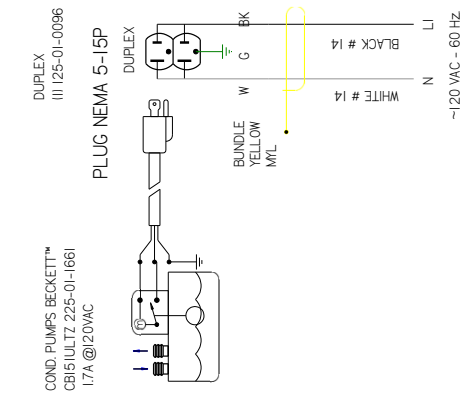
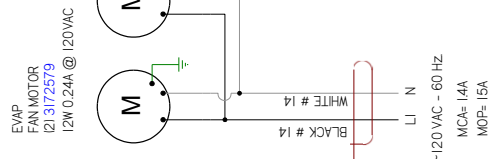
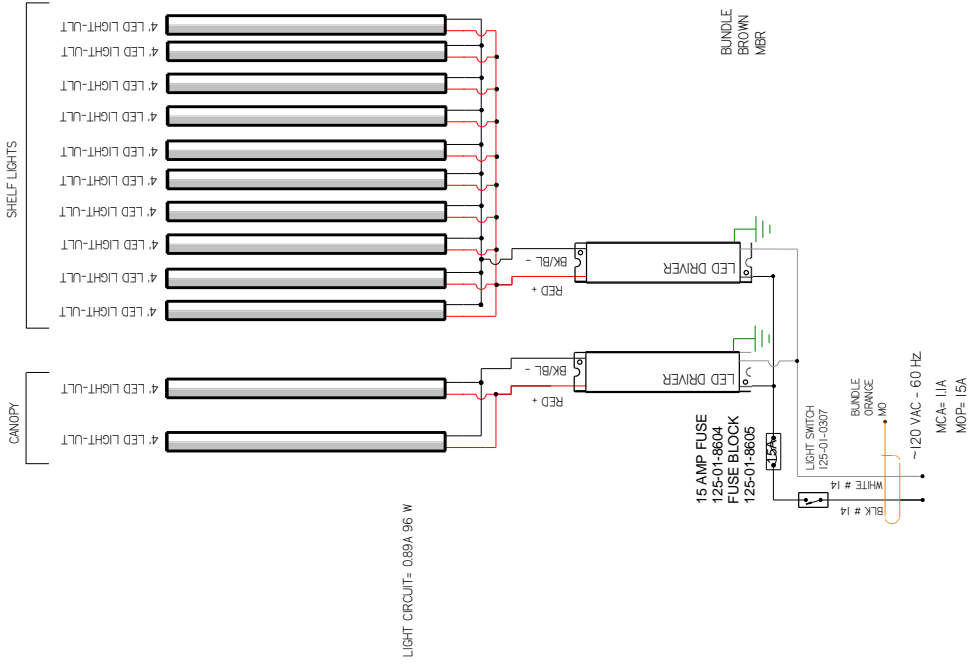

- NOTES:
1. PRINTED DOCUMENT REQUIRED SETTING: ALL COLORS BLACK & WHITE
 2. CASE & ANY REMOVABLE PANEL WITH ELECTRICAL PARTS MUST BE GROUNDED.
 3. WHEN PASSING WIRES THROUGH METAL HOLES A GROMMET MUST BE USED

WIRE MARKER COLORS/ABBREVIATIONS:

BLACK = MBK	MAROON =
BLUE = MBL	MMR ORANGE =
BROWN = MBR	MO PINK = MPI
DARK BLUE = MDB	PURPLE = MP
GREEN = MG	RED = MR
LIGHT BLUE = MLB	YELLOW = MYL

UL COLOR CODES / ABBREVIATIONS:

RED = RD	WHITE = WT
BLACK = BK	GREEN = GN
BLUE = BL	BROWN = BN
YELLOW = YL	ORANGE = OR
GRAY = GR	OR VIOLET = VT

FACTORY 14GA WIRE

FACTORY 14GA WIRE
FIELD WIRE
DO NOT SCALE DRAWING

HUSSMANN
DIAGRAM-RGD-24-7
2-8-S XR75
3160937
 SHEET 1 OF 3

CIRCUIT #2

	LOADING
	208 240 V
L1	17.3 20.0
L2	17.3 20.0

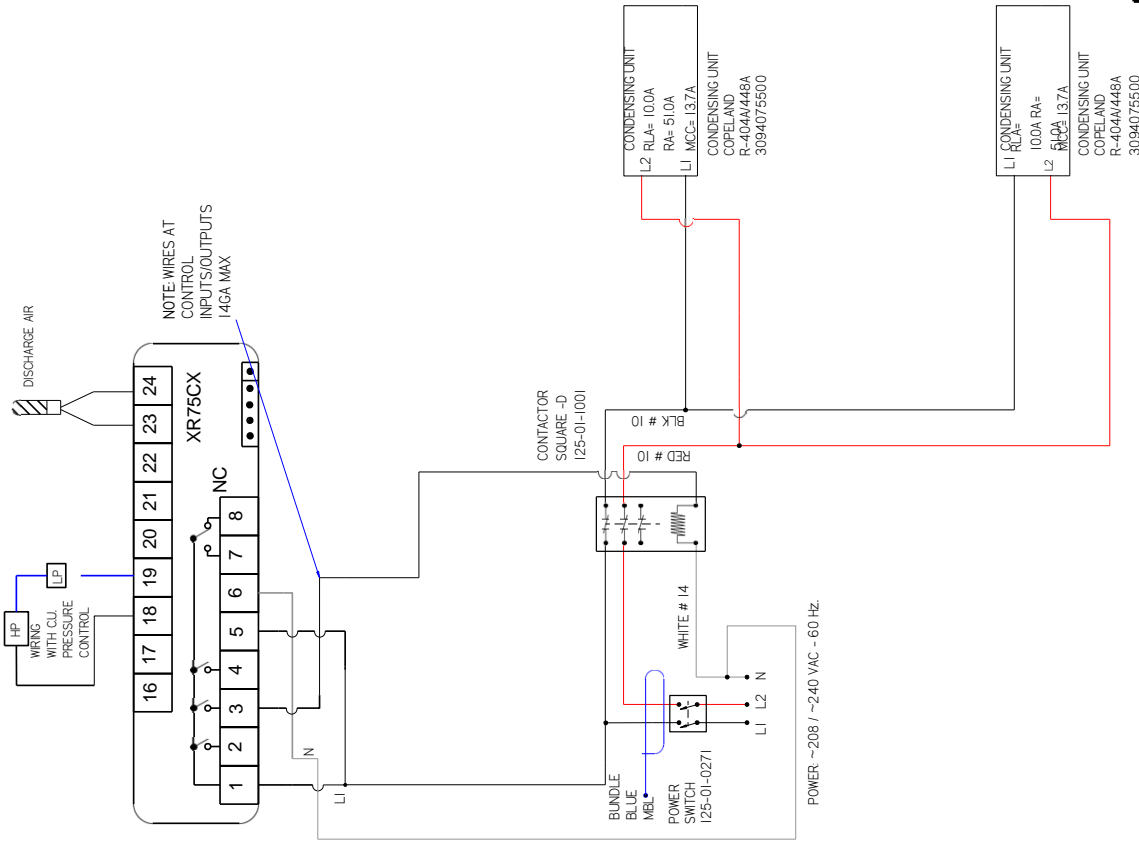

WIRE MARKER COLORS/ABBREVIATIONS

BLACK	= MBK
BLUE	= MBL
BROWN	= MBR
DARK BLUE	= MDB
GREEN	= MG
LIGHT BLUE	= MLB
MAROON	=
MMR ORANGE	=
MO PINK	= MPI
PURPLE	= MP
RED	= MR
YELLOW	= MYL

UL COLOR CODES / ABBREVIATIONS

RED = RD	WHITE = WT
BLACK = BK	GREEN = GN
BLUE = BL	BROWN = BN
YELLOW = YL	ORANGE = OR
YL GRAY = YL GRAY	OR VIOLET = VT
GY	

FACTORY 14GA WIRE
 _FACTORY 10GA WIRE
 _ _ _ _ _FIELD WIRE
 DO NOT SCALE DRAWING
 SHEET 2 OF 3

HUSSMANN
 DIAGRAM-RGD-24-7
 2-8-S XR75
 3160937
 B

- NOTES:
1. PRINTED DOCUMENT REQUIRED SETTING. ALL COLORS BLACK & WHITE
 2. CASE & ANY REMOVABLE PANEL WITH ELECTRICAL PARTS MUST BE GROUNDED.
 3. WHEN PASSING WIRES THROUGH METAL HOLES A GROMMET MUST BE USED

L10 10 WIRE DIAGRAM SIZE 3

CIRCUIT #3

LOADING	
208	240 V
L1	10.8
L2	12.5

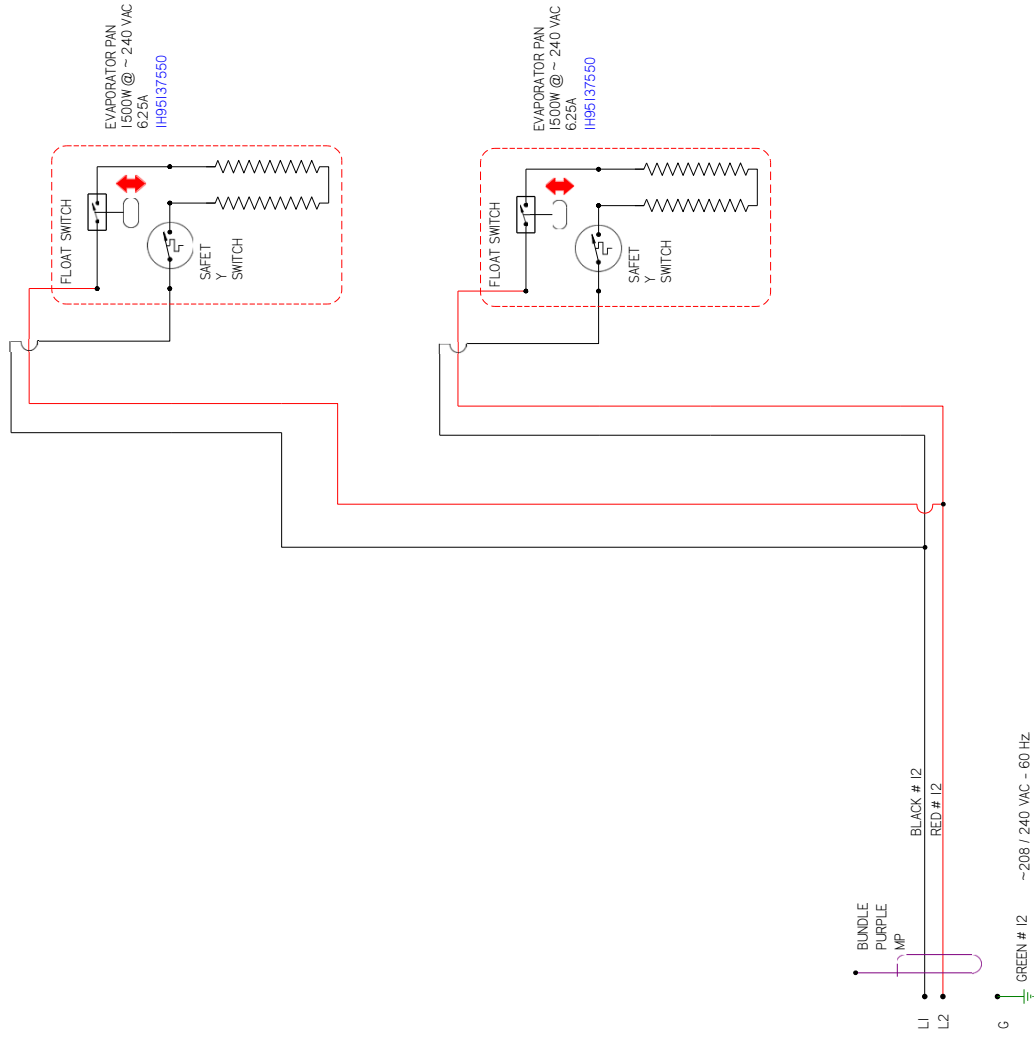

WIRE MARKER COLORS/ABBREVIATIONS

BLACK = MBK	MAROON =
BLUE = MBL	MMR ORANGE =
BROWN = MBR	MO PINK = MPI
DARK BLUE = MDB	PURPLE = MP
GREEN = MG	RED = MR
LIGHT BLUE = MLB	YELLOW = MYL

UL COLOR CODES / ABBREVIATIONS

RED = RD	WHITE = WT
BLACK = BK	GREEN = GN
BLUE = BL	BROWN = BN
YELLOW =	ORANGE =
YL GRAY =	OR VIOLET =
GY	VT

FACTORY 14GA WIRE

FACTORY 10GA WIRE

FIELD WIRE

DO NOT SCALE DRAWING

SHEET 3 OF 3

HUSSMANN

DIAGRAM-RGD-24-7

2-8-S XR75

3160937

B

- NOTES:
1. PRINTED DOCUMENT REQUIRED SETTING: ALL COLORS BLACK & WHITE
 2. CASE & ANY REMOVABLE PANEL WITH ELECTRICAL PARTS MUST BE GROUNDED.
 3. WHEN PASSING WIRES THROUGH METAL HOLES A GROMMET MUST BE USED

REVISION HISTORY			
REV	ECN	DATE	REVISION DESCRIPTION
B	ECN-COD-00152566	3-4-22	NEW LIGHTS
C	ECN-COD-00152566	1-10-24	CHANGE FAN MOTOR

REV	ECN	DATE	REVISION DESCRIPTION
B	ECN-COD-00152566	3-4-22	NEW LIGHTS
C	ECN-COD-00152566	1-10-24	CHANGE FAN MOTOR

CIRCUIT #1	LOADING
208	240 V
L1	16.2
L2	14.1
	16.3

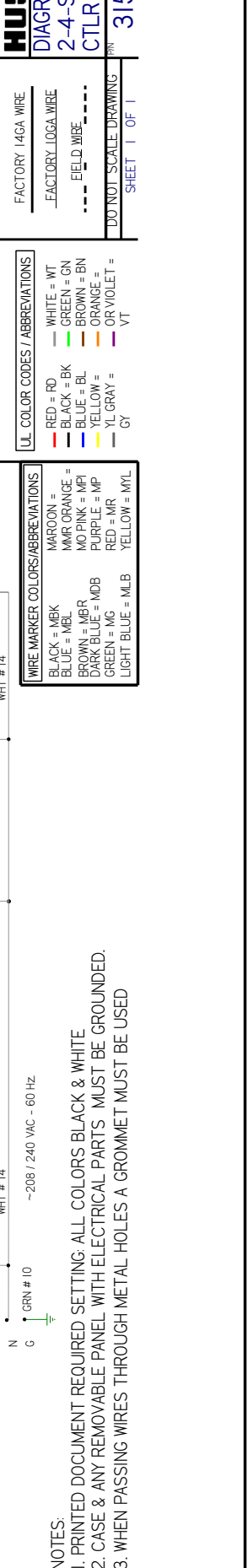
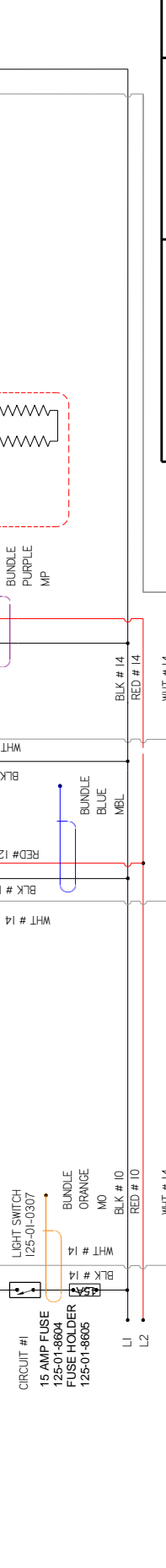
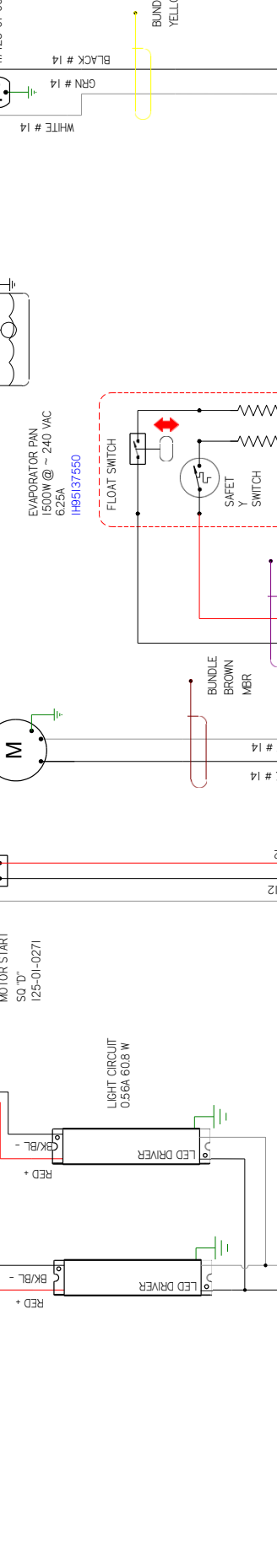
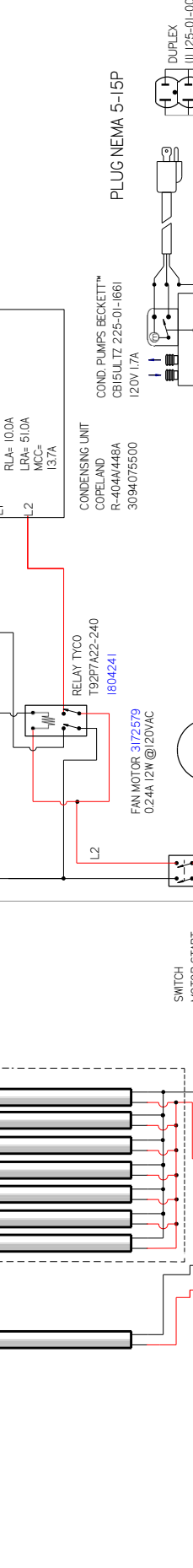
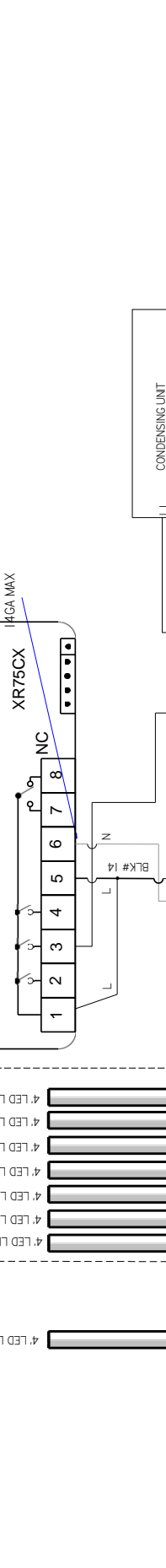
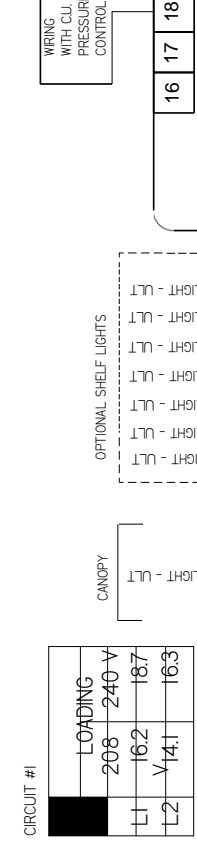

NOTES:
 1. PRINTED DOCUMENT REQUIRED SETTING: ALL COLORS BLACK & WHITE
 2. CASE & ANY REMOVABLE PANEL WITH ELECTRICAL PARTS MUST BE GROUNDED.
 3. WHEN PASSING WIRES THROUGH METAL HOLES A GROMMET MUST BE USED

DISCHARGE AIR
 WIRING WITH C.U. PRESSURE CONTROL
 NOTE WIRES AT CONTROL INPUTS/OUTPUTS 14GA MAX

CONDENSING UNIT
 RLA= 10.0A
 LRA= 51.0A
 MCC= 13.7A

CONDENSING UNIT
 COPELAND
 R-404A/448A
 3094075500

COND. PUMPS BECKETT™
 CB15ULTZ 2.25-01-1661
 120V 17A

EVAPORATOR PAN
 1500W @ ~ 240 VAC
 6.25A
 IH95137550

FAN MOTOR 3172579
 0.24A 12W @120VAC

RELAY TYCO
 T92P7A22-240
 1804241

SWITCH MOTOR START
 S0. D™
 125-01-0271

PLUG NEMA 5-15P

DUPLEX
 III 125-01-0036

UL COLOR CODES / ABBREVIATIONS
 RED = RD
 BLACK = BK
 BLUE = BL
 BROWN = BRN
 DARK BLUE = MDB
 GREEN = MG
 LIGHT BLUE = MLB
 MAROON = MRO
 MMR ORANGE = MMR ORG
 MO PINK = MPI
 DARK BLUE = MDB
 GREEN = MG
 LIGHT BLUE = MLB

WIRE MARKER COLORS/ABBREVIATIONS
 BLACK = MBK
 BLUE = MBL
 BROWN = MBR
 DARK BLUE = MDB
 GREEN = MGR
 LIGHT BLUE = MBLB
 MAROON = MRO
 MMR ORANGE = MMR ORG
 MO PINK = MPI
 PURPLE = MPP
 RED = MR
 YELLOW = MYL

FACTORY 14GA WIRE
 _FACTORY 10GA WIRE
 _FIELD WIRE
 _OR VIOLET = VT

DO NOT SCALE DRAWING
 SHEET 1 OF 1

UL COLOR CODES / ABBREVIATIONS
 WHITE = WT
 GREEN = GN
 BROWN = BN
 ORANGE = OR
 YL GRAY = YL GRAY
 VT

WIRE MARKER COLORS/ABBREVIATIONS
 BLACK = MBK
 BLUE = MBL
 BROWN = MBR
 DARK BLUE = MDB
 GREEN = MGR
 LIGHT BLUE = MBLB
 MAROON = MRO
 MMR ORANGE = MMR ORG
 MO PINK = MPI
 PURPLE = MPP
 RED = MR
 YELLOW = MYL

FACTORY 14GA WIRE
 _FACTORY 10GA WIRE
 _FIELD WIRE
 _OR VIOLET = VT

DO NOT SCALE DRAWING
 SHEET 1 OF 1

UL COLOR CODES / ABBREVIATIONS
 WHITE = WT
 GREEN = GN
 BROWN = BN
 ORANGE = OR
 YL GRAY = YL GRAY
 VT

WIRE MARKER COLORS/ABBREVIATIONS
 BLACK = MBK
 BLUE = MBL
 BROWN = MBR
 DARK BLUE = MDB
 GREEN = MGR
 LIGHT BLUE = MBLB
 MAROON = MRO
 MMR ORANGE = MMR ORG
 MO PINK = MPI
 PURPLE = MPP
 RED = MR
 YELLOW = MYL

3157197

HUSSMANN
 DIAGRAM-RGD-30-7
 2-4-S WXRXT5
 CTLR

CIRCUIT #1

LOADING	
208V/240 V	
L1	18.7 21.6
L2	16.4 18.9

CANOPY LIGHTS

LIGHT CIRCUIT= .57A 614W

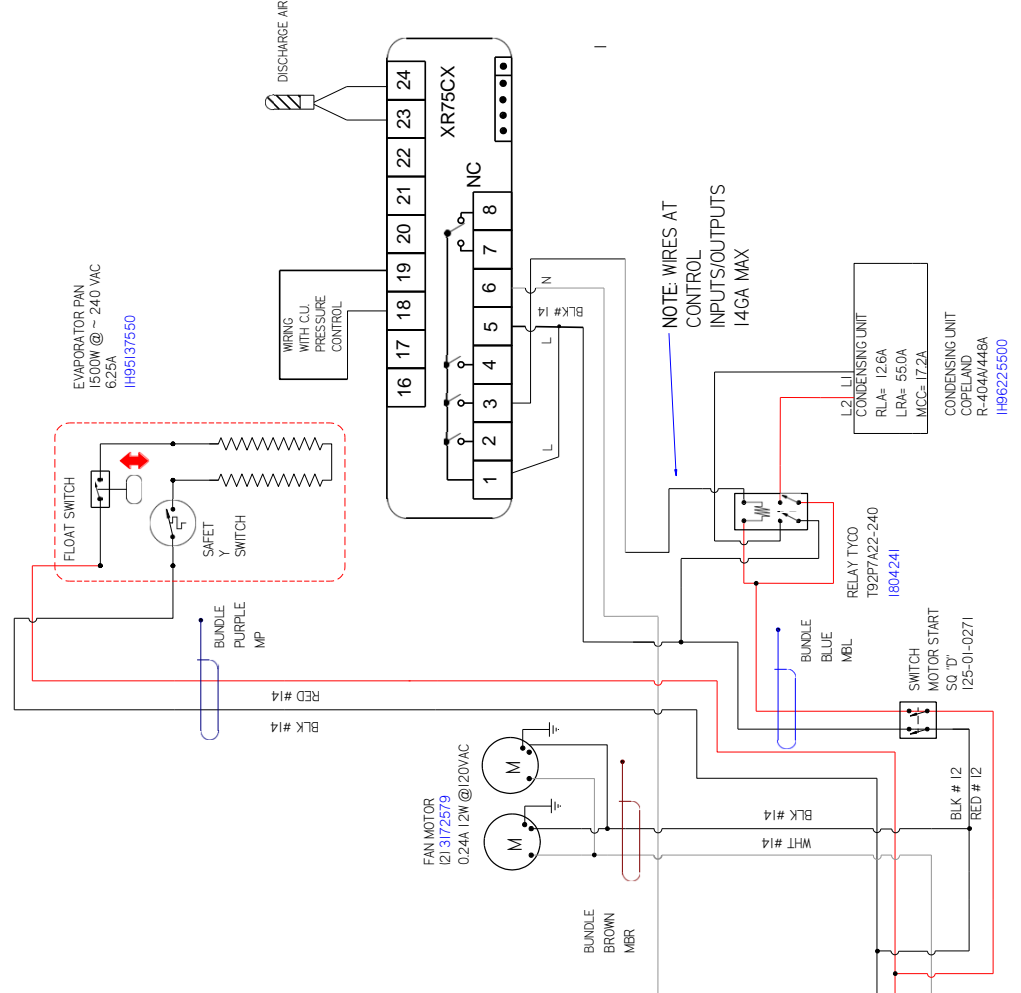
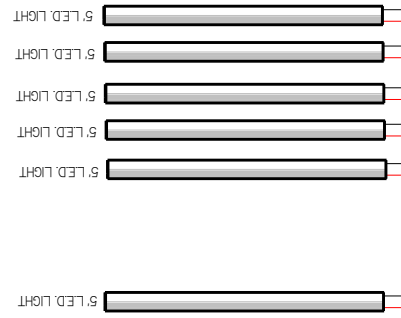

REVISION HISTORY			
REV	ECN	DATE	REVISION DESCRIPTION
A	ECN-COD-0015287	4-22-22	RELEASED TO PRODUCTION
B	ECN-COD-0019015	1-10-24	CHANGED FAN MOTORS

REV	CHKD BY	APPR BY
A	CB	CB
B	CB	CB

EVAPORATOR PAN
1500W @ ~ 240 VAC
625A
IH95137550

DUPLEX
(11) 125-01-0096
PLUG NEMA 5-15P

COND. PUMPS BECKETT™
CB151ULTZ 225-01-1661
1.7A @20VAC

FAN MOTOR
I21-3172579
0.24A 12W @20VAC

NOTE: WIRES AT
CONTROL
INPUTS/OUTPUTS
14GA MAX

CONDENSING UNIT
RLA= 126A
LRA= 550A
MCC= 172A

CONDENSING UNIT
COPELAND
R-404A/446A
IH86225500

-208/240 VAC - 60 HZ.

WIRE MARKER COLORS/ABBREVIATIONS	
BLACK = MBK	MAROON =
BLUE = MBL	MMR ORANGE =
BROWN = MBR	MO PINK = MPI
DARK BLUE = MDB	PURPLE = MP
GREEN = MG	RED = MR
LIGHT BLUE = MLB	YELLOW = MYL

UL COLOR CODES / ABBREVIATIONS	
RED = RD	WHITE = WT
BLACK = BK	GREEN = GN
BLUE = BL	BROWN = BN
YELLOW = YL	ORANGE = OR
GRAY = GR	OR VIOLET =
	VT

- NOTES:
1. PRINTED DOCUMENT REQUIRED SETTING: ALL COLORS BLACK & WHITE
 2. CASE & ANY REMOVABLE PANEL WITH ELECTRICAL PARTS MUST BE GROUNDED.
 3. WHEN PASSING WIRES THROUGH METAL HOLES A GROMMET MUST BE USED

HUSSMANN
DIAGRAM-RGD-30-7
2-5-S WXR75
CTLR
3164902
REV B

FACTORY 14GA WIRE	
FACTORY 10GA WIRE	---
FIELD WIRE	---
DO NOT SCALE DRAWING	---
SHEET 1 OF 1	---

REV	ECN	DATE	REVISION DESCRIPTION	REV BY	CHKD BY	APPR BY
B	ECN-COD-0018256	3-7-22	NEW LIGHTS	AL	CB	CB
C	ECN-COD-00189015	1-10-24	CHANGED FAN MOTORS	CB	CB	CB

REVISION HISTORY	
EVAPORATOR PAN 1500W @ ~ 240 VAC 6.25A IH96137550	

LOADING	CIRCUIT #1
208V/240 V	
L1 190 219	
L2 164 189	

COND. PUMPS BECKETT™
CB151ULTZ 225-01-1661
1.7A @120VAC

PLUG NEMA 5-15P
DUPLX
III 125-01-0096

LIGHT CIRCUIT INPUT
0.85A 918W @ 120 VAC

OPTIONAL SHELF LIGHTS

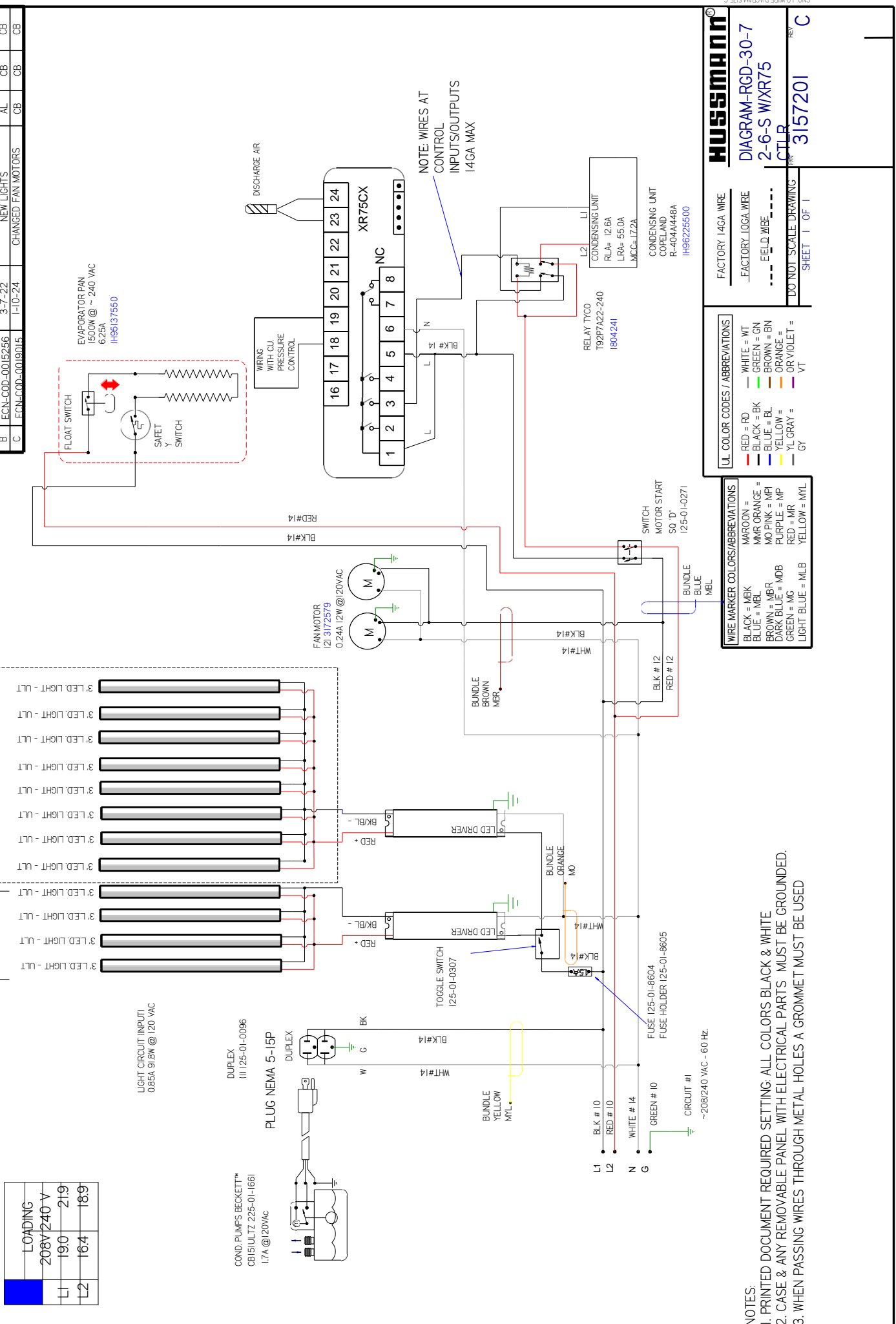

NOTE: WIRES AT CONTROL INPUTS/OUTPUTS 14GA MAX

WIRING WITH CU PRESSURE CONTROL

RELAY TYCO T92P7A22-240 (804241)

CONDENSING UNIT COPELAND R-404A448A IH96225500

FAN MOTOR (2) 3172579 0.24A 12W @120VAC

SWITCH MOTOR START 50 'D' 125-01-0271

BUCKET

TOGGLE SWITCH 125-01-0307

FUSE HOLDER 125-01-8605

DISCHARGE AIR

BUNDLE BROWN MBR

LED DRIVER

XR75CX

BUNDLE ORANGE MO

LED DRIVER

CONDENSING UNIT

BUNDLE BLUE MBL

LED DRIVER

RELAY

BUNDLE YELLOW MYL

LED DRIVER

CONDENSING UNIT

BUNDLE GREEN MG

LED DRIVER

RELAY

BUNDLE MAROON MMR

LED DRIVER

CONDENSING UNIT

BUNDLE PINK MPI

LED DRIVER

RELAY

BUNDLE PURPLE MP

LED DRIVER

CONDENSING UNIT

BUNDLE RED MR

LED DRIVER

RELAY

BUNDLE LIGHT BLUE MBL

LED DRIVER

CONDENSING UNIT

BUNDLE BLACK MBK

LED DRIVER

RELAY

BUNDLE WHITE WT

LED DRIVER

CONDENSING UNIT

BUNDLE GREEN GN

LED DRIVER

RELAY

BUNDLE BROWN BN

LED DRIVER

CONDENSING UNIT

BUNDLE ORANGE =

LED DRIVER

RELAY

BUNDLE YELLOW =

LED DRIVER

CONDENSING UNIT

BUNDLE GRAY =

LED DRIVER

RELAY

BUNDLE CY

LED DRIVER

CONDENSING UNIT

BUNDLE VIOLET =

LED DRIVER

RELAY

BUNDLE BK

LED DRIVER

CONDENSING UNIT

BUNDLE BL

LED DRIVER

RELAY

BUNDLE YL

LED DRIVER

CONDENSING UNIT

BUNDLE GR

LED DRIVER

RELAY

BUNDLE WT

LED DRIVER

CONDENSING UNIT

BUNDLE GN

LED DRIVER

RELAY

BUNDLE BN

LED DRIVER

CONDENSING UNIT

BUNDLE OR

LED DRIVER

RELAY

BUNDLE YL

LED DRIVER

CONDENSING UNIT

BUNDLE GR

LED DRIVER

RELAY

BUNDLE VIO

LED DRIVER

CONDENSING UNIT

BUNDLE BK

LED DRIVER

RELAY

BUNDLE BL

LED DRIVER

CONDENSING UNIT

BUNDLE YL

LED DRIVER

RELAY

BUNDLE GR

LED DRIVER

CONDENSING UNIT

BUNDLE VIO

LED DRIVER

RELAY

BUNDLE BK

LED DRIVER

CONDENSING UNIT

BUNDLE BL

LED DRIVER

RELAY

BUNDLE YL

LED DRIVER

CONDENSING UNIT

BUNDLE GR

LED DRIVER

RELAY

BUNDLE VIO

LED DRIVER

CONDENSING UNIT

NOTES:
1. PRINTED DOCUMENT REQUIRED SETTING: ALL COLORS BLACK & WHITE
2. CASE & ANY REMOVABLE PANEL WITH ELECTRICAL PARTS MUST BE GROUNDED.
3. WHEN PASSING WIRES THROUGH METAL HOLES A GROMMET MUST BE USED

UL COLOR CODES / ABBREVIATIONS	
RED = RD	WHITE = WT
BLACK = BK	GREEN = GN
BLUE = BL	BROWN = BN
YELLOW = YL	ORANGE = OR
GRAY = GR	VIOLET = VT

WIRE MARKER COLORS/ABBREVIATIONS	
BLACK = MBK	MAROON =
BLUE = MBL	MNR ORANGE =
BROWN = MBR	MO PINK = MPI
DARK BLUE = MDB	PURPLE = MP
GREEN = MG	RED = MR
LIGHT BLUE = MLB	YELLOW = MYL

FACTORY 14GA WIRE	
FACTORY 14GA WIRE	
FIELD WIRE	

DO NOT SCALE DRAWING	
SHEET 1 OF 1	

HUSSMANN
DIAGRAM-RGD-30-7
2-6-S WXR75
 CTRL
3157201

CIRCUIT #1

LOADING
120 V
LI 3.1

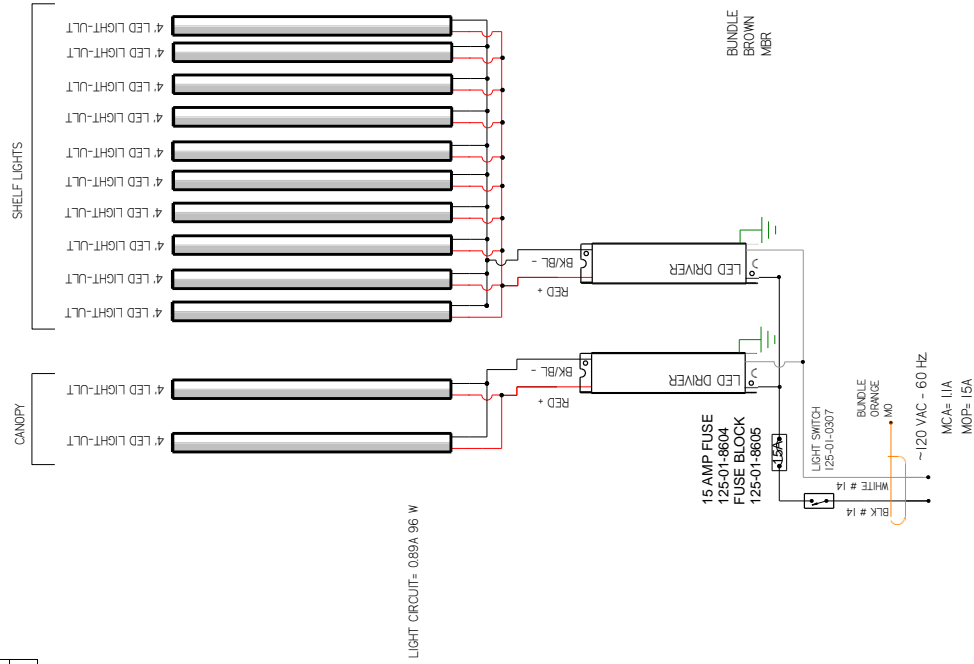

LIGHT CIRCUIT= 0.89A 96 W

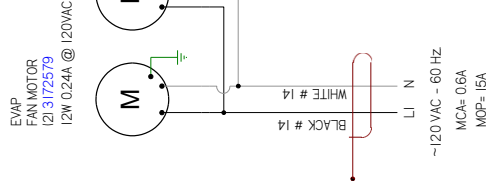

EVAP FAN MOTOR
12V 0.24A @ 120VAC
MCA= 0.6A
MOP= 15A

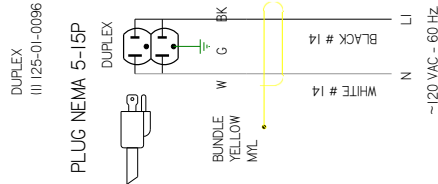

COND. PUMPS BECKETT™
CB15LULTZ, 225-01-1661
1.7A @ 120VAC



PLUG NEMA 5-15P
III 125-01-0096

REVISION HISTORY			
REV	ECN	DATE	REVISION DESCRIPTION
A	ECN-COD-001637Z	01-31-22	RELEASED TO PRODUCTION
B	ECN-COD-00169115	1-10-24	CHANGED FAN MOTORS

REV BY CHKD BY APPR BY	
AL	CB
CB	CB

HUSSMANN
DIAGRAM-RGD-30-7
2-8-S XR75CX

FACTORY 14GA WIRE
_FACTORY 10GA WIRE
--- FIELD WIRE
--- DO NOT SCALE DRAWING

UL COLOR CODES / ABBREVIATIONS
RED = RD
BLACK = BK
BLUE = BL
BROWN = BR
DARK BLUE = MDB
GREEN = MG
LIGHT BLUE = MLB
MAROON = MRO
MMR ORANGE = MMR
MO PINK = MPI
PURPLE = MP
RED = MR
YELLOW = MYL

WIRE MARKER COLORS/ABBREVIATIONS
BLACK = MBK
BLUE = MBL
BROWN = MBR
DARK BLUE = MDB
GREEN = MG
LIGHT BLUE = MLB
MAROON = MRO
MMR ORANGE = MMR
MO PINK = MPI
PURPLE = MP
RED = MR
YELLOW = MYL

DO NOT SCALE DRAWING
SHEET 1 OF 3

3160914
B

- NOTES:
1. PRINTED DOCUMENT REQUIRED SETTING: ALL COLORS BLACK & WHITE
 2. CASE & ANY REMOVABLE PANEL WITH ELECTRICAL PARTS MUST BE GROUNDED.
 3. WHEN PASSING WIRES THROUGH METAL HOLES A GROMMET MUST BE USED

CIRCUIT #2

LOADING	
208	240-V
L1	17.3 200
L2	17.3 200

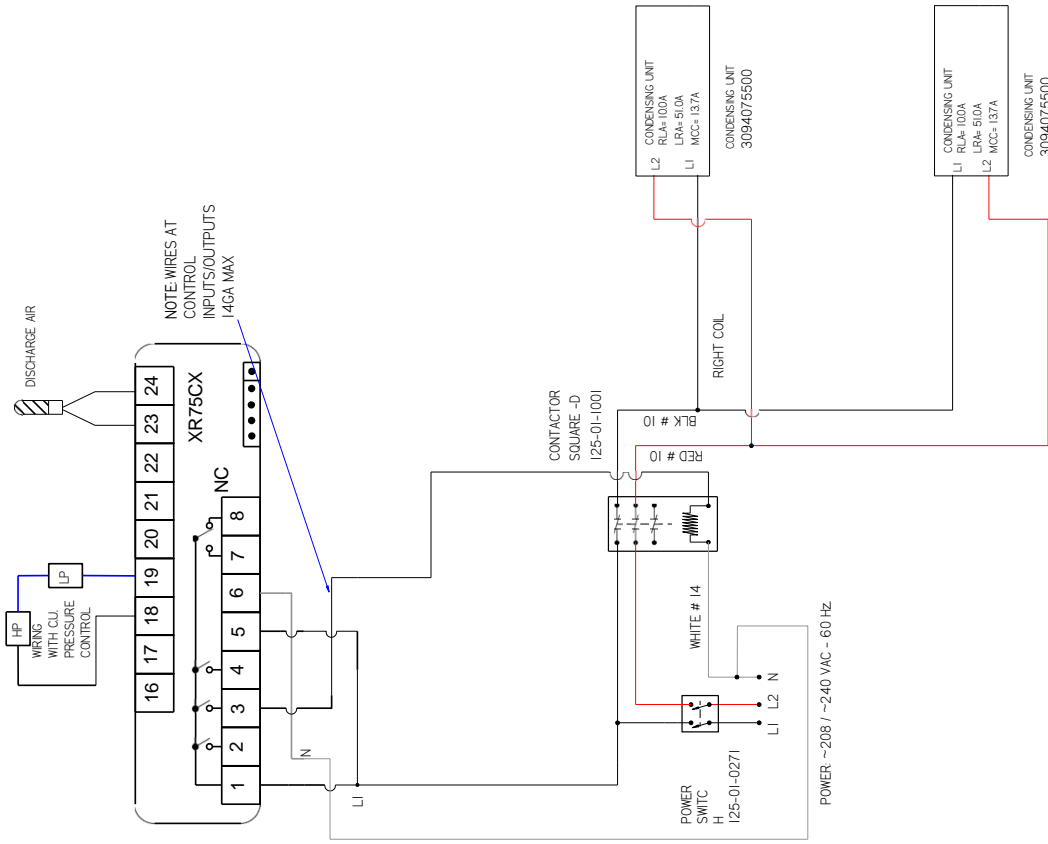

NOTE: WIRES AT CONTROL INPUTS/OUTPUTS 14GA MAX

WIRE MARKER COLORS/ABBREVIATIONS

BLACK = MBK	MAROON =
BLUE = MBL	MMR ORANGE =
BROWN = MBR	MO PINK = MPI
DARK BLUE = MDB	PURPLE = MP
GREEN = MG	RED = MR
LIGHT BLUE = MLB	YELLOW = MYL

UL COLOR CODES / ABBREVIATIONS

RED = RD	WHITE = WT
BLACK = BK	GREEN = GN
BLUE = BL	BROWN = BN
YELLOW =	ORANGE =
YL GRAY =	OR VIOLET =
GY	VT

FACTORY 14GA WIRE

FACTORY 10GA WIRE
FIELD WIRE

DO NOT SCALE DRAWING

SHEET 2 OF 3

HUSSMANN
DIAGRAM-RGD-30-7
2-8-S XR75CX
3160914 | **B**

- NOTES:**
1. PRINTED DOCUMENT REQUIRED SETTING. ALL COLORS BLACK & WHITE
 2. CASE & ANY REMOVABLE PANEL WITH ELECTRICAL PARTS MUST BE GROUNDED.
 3. WHEN PASSING WIRES THROUGH METAL HOLES A GROMMET MUST BE USED

CIRCUIT #3

	LOADING
	208 / 240 V
L1	10.8 / 12.5
L2	10.8 / 12.5

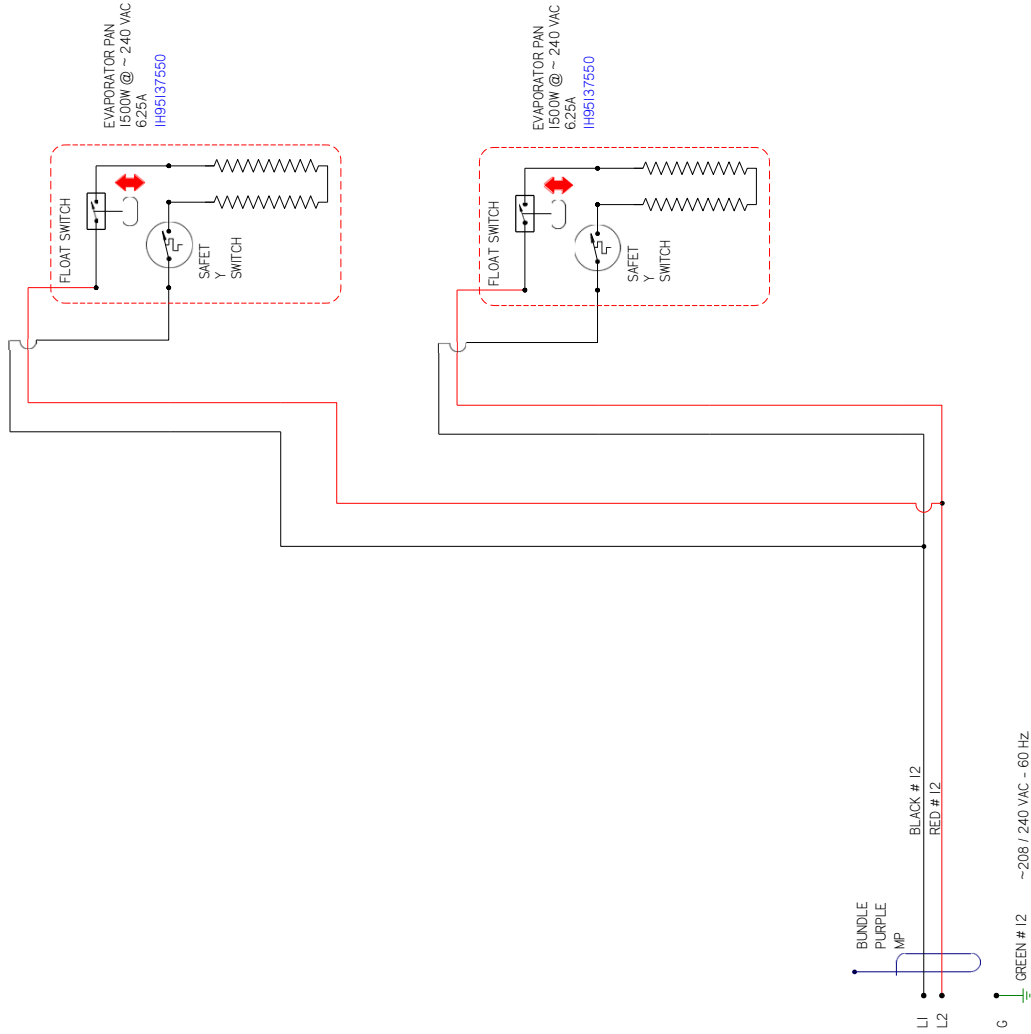

WIRE MARKER COLORS/ABBREVIATIONS

BLACK = MBK	MAROON =
BLUE = MBL	MMR ORANGE =
BROWN = MBR	MO PINK = MPI
DARK BLUE = MDB	PURPLE = MP
GREEN = MG	RED = MR
LIGHT BLUE = MLB	YELLOW = MYL

UL COLOR CODES / ABBREVIATIONS

RED = RD	WHITE = WT
BLACK = BK	GREEN = GN
BLUE = BL	BROWN = BN
YELLOW =	ORANGE =
YL GRAY =	OR VIOLET =
GY	VT

HUSSMANN
DIAGRAM-RGD-30-7
2-8-S XRT75CX

FACTORY 14GA WIRE
_FACTORY 10GA WIRE
_ _ _ _ _FIELD WIRE
_ _ _ _ _DO NOT SCALE DRAWING

3160914
SHEET 3 OF 3

- NOTES:
1. PRINTED DOCUMENT REQUIRED SETTING: ALL COLORS BLACK & WHITE
 2. CASE & ANY REMOVABLE PANEL WITH ELECTRICAL PARTS MUST BE GROUNDED.
 3. WHEN PASSING WIRES THROUGH METAL HOLES A GROMMET MUST BE USED

15. Troubleshooting

Problem	Possible Cause	Possible Solution
Case temperature is too warm.	Ambient conditions may be affecting the case operation.	Check case position in store. Is the case located near an open door, window, electric fan or air conditioning vent that may cause air currents? Case must be located minimum 15 Ft away from doors or windows. Cases are designed to operate at 55% Relative humidity and a temperature of 75°F.
	Discharge air temp is out of spec.	Check evaporator fan operation. Check electrical connections and input voltage.
		Fans are installed backwards. Check airflow direction.
		Fan blades are installed incorrectly. Make sure fan blades have correct pitch and are per specification.
		Check to see that fan plenum is installed correctly. It should not have any gaps.
		Check suction pressure and insure that it meets factory specifications.
	Case is in defrost.	Check defrost settings. See Technical Specifications section.
	Product load may be over its limits blocking airflow.	Redistribute product so it does not exceed load level. There is a sticker on the inside of the case indicating what the maximum load line is.
	Coil is freezing over.	Return air is blocked, make sure debris is not blocking the intake section.
Coil close-offs are not installed. Inspect coil to make sure these parts are on the case.		
Condensing coil or evaporator coil is clogged or dirty.	Clean coil.	
Case temperature is too cold.	The t-stat temp is set too low.	Check settings. See Technical Specifications section.
	Ambient conditions may be affecting the case operation.	Check case position in store. Is the case located near an open door, window, electric fan or air conditioning vent that may cause air currents? Case must be located minimum 15 Ft away from doors or windows. Cases are designed to operate at 55% Relative humidity and a temperature of 75°F.
Condensation on glass.	Ambient conditions may be affecting the case operation.	Check case position in store. Is the case located near an open door, window, electric fan or air conditioning vent that may cause air currents? Case must be located minimum 15 Ft away from doors or windows. Cases are designed to operate at 55% Relative humidity and a temperature of 75°F.
	Inadequate air circulation.	Check if air sweep fans are functioning, check electrical connections.
	There is not enough heat provided in the airflow.	Check if air sweep heater is functioning, check electrical connections.
	There are glass gaps on the side of the case.	See glass adjustment section.
	Glass is not completely shut.	Close glass correctly.

Troubleshooting (Cont'd)

Problem	Possible Cause	Possible Solution
Water has pooled under case.	Case drain is clogged.	Clear drain.
	PVC drains under case may have a leak.	Repair as needed.
	Case tub has unsealed opening.	Seal as needed.
	If the case is in a line-up, case to case joint is missing or unsealed.	Install case to case joint and seal as needed.
	Evaporator pan is overflowing (if applicable).	Check electrical connection to evaporator pan. Check float assembly, it should move freely up and down the support stem. Clear any debris.
Case is not draining properly.	Case is not level.	Level the case.
	Drain screen is plugged.	Clean drain screen and remove any debris.
	Drain or P-trap is clogged.	Clear any debris.
Frost or ice on evaporator coil.	Evaporator fans are not functioning.	Check electrical connections.
	Defrost clock is not functioning.	Case should be serviced by a qualified service technician.
	Coil is freezing over.	Return air is blocked, make sure debris is not blocking the intake section.
		Coil close-offs are not installed. Inspect coil to make sure these parts are on the case.
Large gap is visible on bottom of front glass or glass can't be opened because it is too low.	Glass Height adjusters need to be adjusted.	See Glass Adjustment section.
Large gaps are visible in between glass panels or glass rubs against end panel.	Glass/glass clamp assembly needs to be adjusted.	See Glass Adjustment section.
Front glass does not stay open and falls closed.	Glass shock/piston may need to be replaced.	Case should be serviced by a qualified service technician.
Lights do not come on.	LED Driver/light socket wiring.	Check electrical connections. See Electrical Section and check wiring diagram.
	Driver needs to be replaced.	Case should be serviced by a qualified service technician. See Electrical Section.
	Lamp socket needs to be replaced.	Case should be serviced by a qualified service technician.
	Lamp needs to be replaced.	See Maintenance Section.
	Light Switch needs to be replaced.	Case should be serviced by a qualified service technician.

16. Appendices

Appendix A. - Temperature Guidelines

The refrigerators should be operated according to the manufacturer's published engineering specifications for entering air temperatures for specific equipment applications. Table 1 shows the typical temperature of the air entering the food zone one hour before the start of defrost and one hour after defrost for various categories of refrigerators. Refer to Appendix C for Field Evaluation Guidelines.

Type of Refrigerator	Typical Entering Air Temperature
I. OPEN DISPLAY	
A. Non frozen:	
1) Meat	28°F
2) Dairy/Deli	32°F
3) Produce	
a. Processed	36°F
b. Unprocessed	45°F
B. Frozen	0°F
C. Ice Cream	-5°F
II. CLOSED DISPLAY	
A. Non frozen:	
1) Meat	34°F
2) Dairy/Deli	34°F
3) Produce	
a. Processed	36°F
b. Unprocessed	45°F
B. Frozen	0°F
C. Ice Cream	-5°F

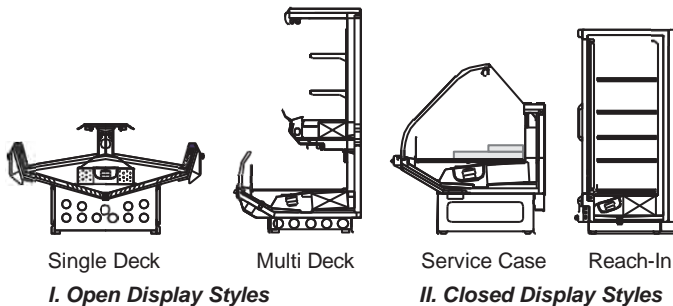

Appendix B. - Application Recommendations

1. Temperature performance is critical for controlling bacteria growth. Therefore, the following recommendations are included in the standard. They are based on confirmed field experience over many years.
2. The installer is responsible for following the installation instructions and recommendations provided by Hussmann for the installation of each individual type refrigerator.
2. Refrigeration piping should be sized according to the equipment manufacturer's recommendations

and installed in accordance with normal refrigeration practices. Refrigeration piping should be insulated according to Hussmann's recommendations.

3. A clogged waste outlet blocks refrigeration. The installer is responsible for the proper installation of the system which dispenses condensate waste through an air gap into the building indirect waste system.
4. The installer should perform a complete start-up evaluation prior to the loading of food into the refrigerator, which includes such items as:
 - a) Initial temperature performance, Coils should be properly fed with a refrigerant according to manufacturer's recommendations.
 - b) Observation of outside influences such as drafts, radiant heating from the ceiling and from lamps. Such influence should be properly corrected or compensated for.
 - c) At the same time, checks should be made of the store dry-bulb and wet-bulb temperatures to ascertain that they are within the limits prescribed by Hussmann.
 - d) Complete start-up procedures should include checking through a defrost to make certain of its adequate frequency and length without substantially exceeding the actual needs. This should include checking the electrical or refrigerant circuits to make sure that defrosts are correctly programmed for all the refrigerators connected to each refrigeration system.
 - e) Recording instruments should be used to check performance.

Appendix C. - Field Recommendations

Recommendations for field evaluating the performance of retail food refrigerators and hot cases

- 1.0 The most consistent indicator of display refrigerator performance is temperature of the air entering the product zone (see Appendix A). In practical use, the precise determination of return air temperature is extremely difficult. Readings of return air temperatures will be variable and results will be inconsistent. The product temperature alone is not an indicator of refrigerator performance.

Appendices (Cont'd)

NOTE: Public Health will use the temperature of the product in determining if the refrigerator will be allowed to display potentially hazardous food. For the purpose of this evaluation, product temperature above the FDA Food Code 1993 temperature for potentially hazardous food will be the first indication that an evaluation should be performed. It is expected that all refrigerators will keep food at the FDA Food Code 1993 temperature for potentially hazardous food.

1. The following recommendations are made for the purpose of arriving at easily taken and understood data which, coupled with other observations, may be used to determine whether a display refrigerator is working as intended:
 - a) **INSTRUMENT** - A stainless steel stem-type thermometer is recommended and it should have a dial a minimum of 1 inch internal diameter. A test thermometer scaled only in Celsius or dually scaled in Celsius and Fahrenheit shall be accurate to 1°C (1.8°F). Temperature measuring devices that are scaled only in Fahrenheit shall be accurate to 2°F. The thermometer should be checked for proper calibration. (It should read 32°F when the stem is immersed in an ice water bath).
 - b) **LOCATION** - The probe or sensing element of the thermometer should be located in the airstream where the air first enters the display or storage area, and not more than 1 inch away from the surface and in the center of the discharge opening.
 - c) **READING** - It should first be determined that the refrigerator is refrigerating and has operated at least one hour since the end of the last defrost period. The thermometer reading should be made only after it has been allowed to stabilize, i.e., maintain a constant reading.
 - d) **OTHER OBSERVATIONS** - Other observations should be made which may indicate operating problems, such as unsatisfactory product, feel/appearance.
 - e) **CONCLUSIONS** - In the absence of any apparent undesirable conditions, the refrigerator should be judged to be operating properly. If it is determined that such condition is undesirable, i.e., the product is above proper temperature, checks should be made for the following:
 1. Has the refrigerator been loaded with warm product?
 2. Is the product loaded beyond the "Safe Load Line" markers?

3. Are the return air ducts blocked?
4. Are the entering air ducts blocked?
5. Is a dumped display causing turbulent air flow and mixing with room air?
6. Are spotlights or other high intensity lighting directed onto the product?
7. Are there unusual draft conditions (from heating/air-conditioning ducts, open doors, etc.)?
8. Is there exposure to direct sunlight?
9. Are display signs blocking or diverting airflow?
10. Are the coils of the refrigerator iced up?
11. Is the store ambient over 75°F, 55% RH as set forth in ASHRAE Standard 72 and ASHRAE Standard 117?
12. Are the shelf positions, number, and size other than recommended by Hussmann?
13. Is there an improper application or control system?
14. Is the evaporator fan motor/blade inoperative?
15. Is the defrost time excessive?
16. Is the defrost termination, thermostat (if used) set too high?
17. Are the refrigerant controls incorrectly adjusted?
18. Is the air entering the condenser above design conditions? Are the condenser fins clear of dirt, dust, etc.?
19. Is there a shortage of refrigerant?
20. Has the equipment been modified to use replacements for CFC-12, CFC-502 or other refrigerant? If so, have the modifications been made in accordance with the recommendations of the equipment manufacturer? Is the refrigerator charged with the proper refrigerant and lubricant? Does the system use the recommended compressor?

Appendix D. - Recommendations to User

- 1.0 Hussmann Corporation provides instructions and recommendations for proper periodic cleaning. The user will be responsible for such cleaning, including the cleaning of low temperature equipment within the compartment and the cooling coil area(s). Cleaning practices, particularly with respect to proper refrigerator unloading and warm-up, must be in accordance with applicable recommendations.

Appendices (Cont'd)

- 1.1 Cleaning of non frozen food equipment should include a weekly cleaning of the food compartment as a minimum to prevent bacteria growth from accumulating. Actual use and products may dictate more frequent cleaning. Circumstances of use and equipment design must also dictate the frequency of cleaning the display areas. Weekly washing down of the storage compartment is also recommended, especially for equipment subject to drippage of milk or other liquids, or the collection of vegetable, meat, crumbs, etc. or other debris or litter. Daily cleaning of the external areas surrounding the storage or display compartments with detergent and water will keep the equipment presentable and prevent grime buildup.
2. Load levels as defined by the manufacturer must be observed.
3. The best preservation is achieved by following these rules:
 - a) Buy quality products.
 - b) Receive perishables from transit equipment at the ideal temperature for the particular product.
 - c) Expedite perishables to the store's storage equipment to avoid unnecessary warm-up and prolonged temperature recovery. Food store refrigerators are not food chillers nor can they reclaim quality lost through previous mishandling.
 - d) Care must be taken when cross merchandising products to ensure that potentially hazardous vegetable products are not placed in non refrigerated areas.
 - e) Display and storage equipment doors should be kept closed during periods of inactivity.
 - f) Minimize the transfer time of perishables from storage to display.
 - g) Keep meat under refrigeration in meat cutting and processing area except for the few moments it is being handled in processing. When a cut or tray of meat is not to be worked on immediately, the procedure should call for returning it to refrigeration.
 - h) Keep tools clean and sanitized. Since mechanical equipment is used for fresh meat processing, all such equipment should be cleaned at least daily and each time a different kind of meat product comes in contact with the tool or equipment.
 - i) Make sure that all refrigeration equipment is installed and adjusted in strict accordance with the manufacturer's recommendations.
 - j) See that all storage and refrigeration equipment is kept in proper working order by routine maintenance.





17. RGD Program Parameters

RGD					PGM0003A01		PGM0003A02	
					TANDARD CASE REV C 8/18/1	Type II CASE REV C 8/18/17	Actual (°C)	Actual (°F)
Parameter	Code	Min	Max	Default				
Temperature (set point)								
Deli (Type I)	---	-50.0°C	50.0°C	2.0°C	-4.4	24	-4.4	24
Thermostat								
Differential	r01	0.1 K	20.0K	2.0 K	4.4	8	2.2	4
Max. limitation of setpoint setting	r02	-49.0°C	50°C	50.0°C	0.0	32	0.0	32
Min. limitation of setpoint setting	r03	-50.0°C	49.0°C	-50.0°C	-4.4	24	-6.7	20
Adjustment of temperature indication	r04	-20.0 K	20.0 K	0.0 K	0.0 K		0.0 K	
Temperature unit (°C=0/°F=1)	r05	0	1	0	1		1	
Correction of the signal from S4	r09	-10.0 K	+10.0 K	0.0 K	0.0 K		0.0 K	
Correction of the signal from S3	r10	-10.0 K	+10.0 K	0.0 K	0.0 K		0.0 K	
Manual service, stop regulation, start regulation (-1, 0, 1)	r12	-1	1	0	1		1	
Displacement of reference during night operation	r13	-10.0 K	10.0 K	0.0 K	0.0 K		0.0 K	
Definition and weighting, if applicable, of thermostat sensors - S4% (100%=S4, 0%=S3)	r15	0%	100%	100%	100%		100%	
The heating function is started a number of degrees below the thermostats cutout temperature	r36	-15.0 K	-3.0 K	-15.0 K	-15.0 K		-15.0 K	
Activation of reference displacement r40	r39	OFF	ON	OFF	OFF		OFF	
Value of reference displacement (activate via r39 or DI)	r40	-50.0 K	50.0 K	0.0 K	0.0 K		0.0 K	
Alarm								
Delay for temperature alarm	A03	0 min	240 min	30 min	30 min		30 min	
Delay for door alarm	A04	0 min	240 min	60 min	60 min		60 min	
Delay for temperature alarm after defrost	A12	0 min	240 min	90 min	60		60	
High alarm limit	A13	-50.0°C	50.0°C	8.0°C	5.0	41	5.0	41
Low alarm limit	A14	-50.0°C	50.0°C	-30.0°C	-9.4	15	-9.4	15
Alarm delay DI1	A27	0 min	240 min	30 min	30 min		30 min	
Alarm delay DI2	A28	0 min	240 min	30 min	30 min		30 min	
Signal for alarm thermostat. S4% (100%=S4, 0%=S3)	A36	0%	100%	100%	100%		100%	
Compressor								
Min. ON-time	c01	0 min	30 min	0 min	1		1	
Min. OFF-time	c02	0 min	30 min	0 min	2		2	
Time delay for cutin of comp.2	c05	0 sec	999 sec	0 sec	0 sec		0 sec	
Compressor relay 1 must cutin and out inversely (NC-function)	c30	0	1	0	0		0	
		OFF	ON	OFF	OFF		OFF	
Defrost								
Defrost method (none/EL/GAS/BRINE)	d01	no	bri	EL	EL		EL	
Defrost stop temperature	d02	0.0°C	25.0°C	6.0°C	8.9	48	8.9	48
Interval between defrost starts	d03	0 hours	240 hours	8 hours	6		2	
Max. defrost duration	d04	0 min	180 min	45 min	25		15	
Displacement of time on cutin of defrost at start-up	d05	0 min	240 min	0 min	0 min		0 min	
Drip off time	d06	0 min	60 min	0 min	0 min		0 min	
Delay for fan start after defrost	d07	0 min	60 min	0 min	0 min		0 min	
Fan start temperature	d08	-15.0°C	0.0°C	-5.0°C	-5.0°C		-5.0°C	
Fan cutin during defrost	d09	0	2	1	1		1	
0: Stopped 1: Running 2: Running during pump down and defrost								
Defrost Sensor (0=time, 1=S5, 2=S4)	d10	0	2	0				
Pump down delay	d16	0 min	60 min	0 min	0 min		0 min	
Drain delay	d17	0 min	60 min	0 min	0 min		0 min	
Max. aggregate refrigeration time between two defrosts	d18	0 hours	48 hours	0 hours				
Defrost on demand - S5 temperature's permitted variation during frost build-up. On central plant choose 20 K (=off)	d19	0.0 K	20.0 k	20.0 K				
Delay of hot gas defrost	d23	0 min	60 min	0 min	0 min		0 min	
Fan								
Fan stop at cutout compressor	F01	no	yes	no	no		no	
Delay of fan stop	F02	0 min	30 min	0 min	0 min		0 min	
Fan stop temperature (S5)	F04	-50.0°C	50.0°C	50.0°C	50.0°C		50.0°C	

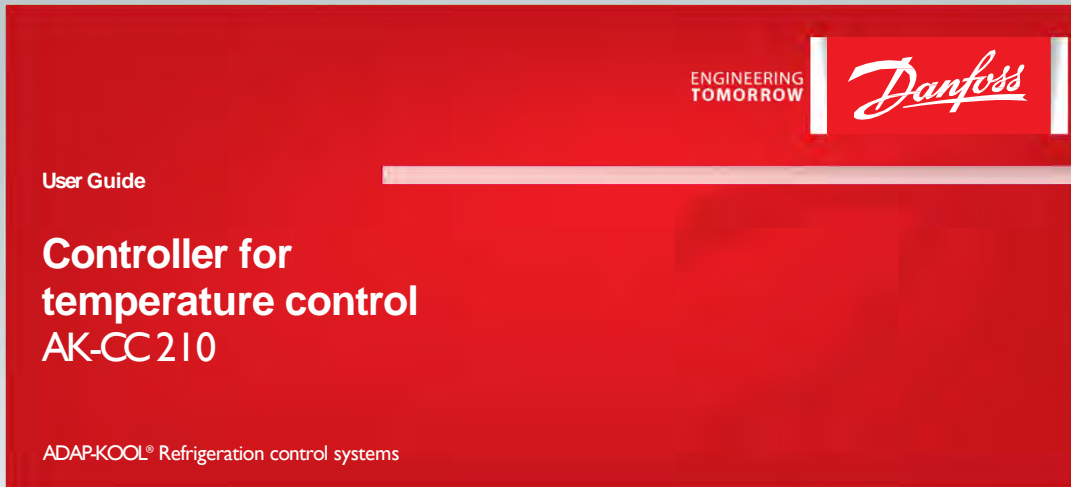
HACCP							
Actual temperature measurement for the HACCP	h01						
Last registered peak temperature	h10						
Selection of function and sensor for the HACCP HACCP function. 1 = S4 used (maybe also S3). 2 = S5	h11	0	2	0	0		0
Alarm limit for the HACCP function	h12	-50.0°C	50.0°C	8.0°C	8.0°C		8.0°C
Time delay for the HACCP alarm	h13	0 min.	240 min.	30 min.	30 min.		30 min.
Select signal for the HACCP function. S4% (100% = S4,	h14	0%	100%	100%	100%		100%
Real time clock							
Six start times for defrost. Setting of hours. 0=OFF	t01-t06	0 hours	23 hours	0 hours	0 hours		0 hours
Six start times for defrost. Setting of minutes. 0=OFF	t11-t16	0 min	59 min	0 min	0 min		0 min
Clock - Setting of hours	t07	0 hours	23 hours	0 hours	0 hours		0 hours
Clock - Setting of minute	t08	0 min	59 min	0 min	0 min		0 min
Clock - Setting of date	t45	1	31	1	1		1
Clock - Setting of month	t46	1	12	1	1		1
Clock - Setting of year	t47	0	99	0	0		0
Miscellaneous							
Delay of output signals after start-up	o01	0 s	600 s	5 s	5 s		5 s
Input signal on DI1. Function:	o02	1	11	0	0		0
Network address	o03	0	240	0	0		0
On/Off switch (Service Pin message)	o04	OFF	ON	OFF	OFF		OFF
Access code 1 (all settings)	o05	0	100	0	0		0
Used sensor type (Pt /PTC/NTC)	o06	Pt	ntc	Pt	Pt		Pt
Display step = 0.5 (normal 0.1 at Pt sensor)	o15	no	yes	no	no		no
Max hold time after coordinated defrost	o16	0 min	60 min	20	20		20
Select signal for display view. S4% (100%=S4,	o17	0%	100%	100%	100%		100%
Input signal on DI2. Function:	o37	0	12	0	0		0
Configuration of light function (relay 4)	o38	1	3	1	1		1
Activation of light relay (only if o38=2)	o39	OFF	ON	OFF	OFF		OFF
Rail heat On time during day operations	o41	0%	100%	100	100		100
Rail heat On time during night operations	o42	0%	100%	100	100		100
Rail heat period time (On time + Off time)	o43	6 min	60 min	10 min	10 min		10 min
Case cleaning. 0=no case cleaning. 1=Fans only. 2=All	o46	0	2	0	0		0
Selection of EL diagram. See overview page 6	o61	1	10	1	1		1
Download a set of predetermined settings. See	o62	0	6	0	0		0
Access code 2 (partly access)	o64	0	100	0	0		0
Save the controllers present settings to the	o65	0	25	0	0		0
Load a set of settings from the programming key	o66	0	25	0	0		0
Replace the controllers factory settings with the	o67	OFF	On	OFF	OFF		OFF
Service							
Status codes are shown on page 17	S0-S33						
Temperature measured with S5 sensor	u09						
Status on DI1 input. on/1=closed	u10						
Temperature measured with S3 sensor	u12						
Status on night operation (on or off) 1=closed	u13						
Temperature measured with S4 sensor	u16						
Thermostat temperature	u17						
Read the present regulation reference	u28						
Status on DI2 output. on/1=closed	u37						
Temperature shown on display	u56						
Measured temperature for alarm thermostat	u57						
Status on relay for cooling	u58						
Status on relay for fan	u59						
Status on relay for defrost	u60						
Status on relay for railheat	u61						
Status on relay for alarm	u62						
Status on relay for light	u63						
Status on relay for valve in suction line	u64						
Status on relay for compressor 2	u67						

18. Danfoss Controller Operations







- ①  Open Camera
- ②  iPhone User
Hold the camera up to the QR code
-  Android User
Open QR Code Reader app if necessary.
Hold the camera up to the QR code
- ③  Tap the notification to be taken to the destination of the QR code

Dixell Controller Operations

026-1210 Rev 3 03-FEB-2015

XR75CX Digital Controller for Medium-Low Temperature Refrigeration Applications Installation and Operation Manual



- ①  Open Camera
- ②  iPhone User
Hold the camera up to the QR code
-  Android User
Open QR Code Reader app if necessary.
Hold the camera up to the QR code
- ③  Tap the notification to be taken to the destination of the QR code



This warning does not mean that Hussmann products will cause cancer or reproductive harm, or is in violation of any product-safety standards or requirements. As clarified by the California State government, Proposition 65 can be considered more of a ‘right to know’ law than a pure product safety law. When used as designed, Hussmann believes that our products are not harmful. We provide the Proposition 65 warning to stay in compliance with California State law. It is your responsibility to provide accurate Proposition 65 warning labels to your customers when necessary. For more information on Proposition 65, please visit the California State government website.

Service Record

Last service date: By:

_____	_____
_____	_____
_____	_____
_____	_____
_____	_____
_____	_____
_____	_____

HUSSmann®/Chino
Additional copies of this publication may be obtained by contacting:
Hussmann® Chino
13770 Ramona Avenue • Chino, California 91710
(909) 628-8942 FAX
(909) 590-4910
(800) 395-9229

The <i>MODEL NAME</i> and <i>SERIAL NUMBER</i> is required in order to provide you with the correct parts and information for your particular unit. They can be found on a small metal plate on the unit. Please note them below for future reference.
MODEL:
SERIAL NUMBER: