

HUSSMANN®/CHINO

TY3, TY4 (ENTYCE)

**HOT/COLD ISLAND
SELF-CONTAINED CASE**

Installation
& Operation
Manual

REV. 1023

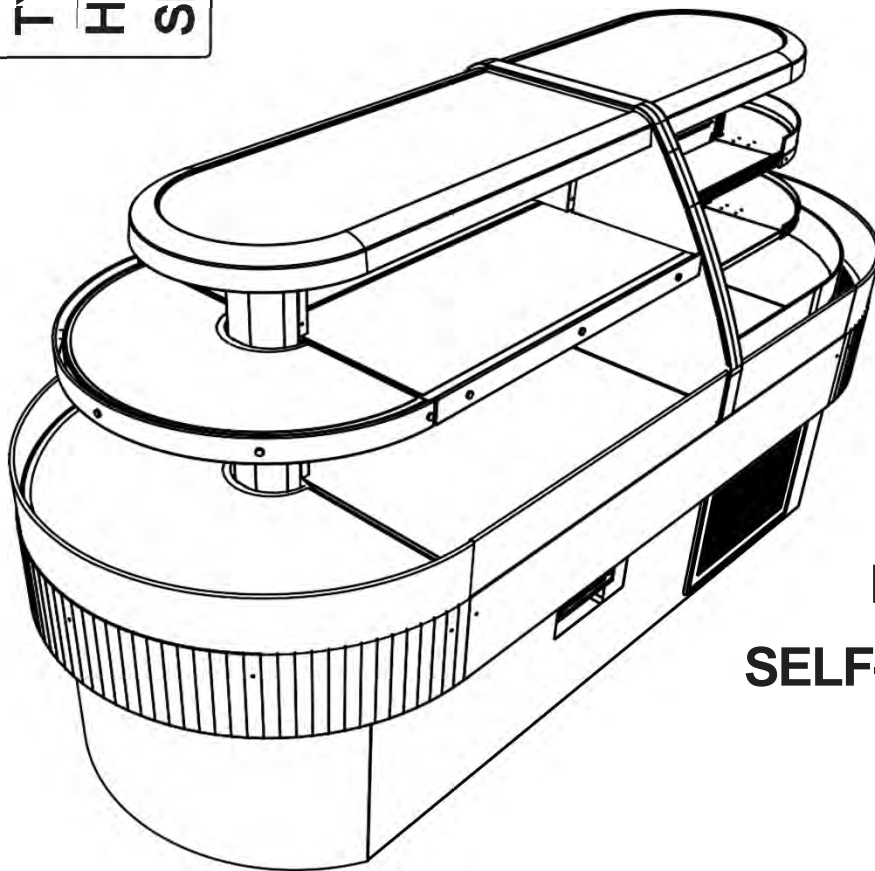

TY3, TY4
(ENTYCE)
HOT/COLD ISLAND
SELF-CONTAINED CASE

Table of Contents

Warning	3
General Information	4
Entyce Hot Cold Lifting Instructions	5
Close-Off Removal	7
TY3 4X4E-S Cold Section	8
Installation	10
Electrical	11
Wiring Diagram Index	12
Wiring Diagram	13
Controller Programmed Parameters	23
TY Cold Maintenance	25
Service Tips	27
Controller Manual	29
Start up Hot Section	31
Standard Hot Case Settings	33
Operation	34
Electrical	35
Wiring Diagram Index	36
Wiring Diagram	37
Cleaning and Maintenance	50
TY Hot Maintenance	53

Warning



1. Do Not Push, Pull, Adjust, or Manipulate the TY case by any glass component.
 - Doing so will result in severe damage to such components
 - Glass breakage may result in serious injury
2. Never stand on the TY Top, Deck, or any Shelves for any reason.
 - Misusing these surfaces as steps will result in damage to the case
 - Misusing these surfaces as steps may result in serious injury to the user
 - These surfaces are intended for the storage and merchandising of food products only
 - Use a ladder or designed structure to work above the case (Do not lean on case)
3. DO NOT remove shelves. WARNING! will adversely impact case performance when merchandising.

Not
Merchadising
Area

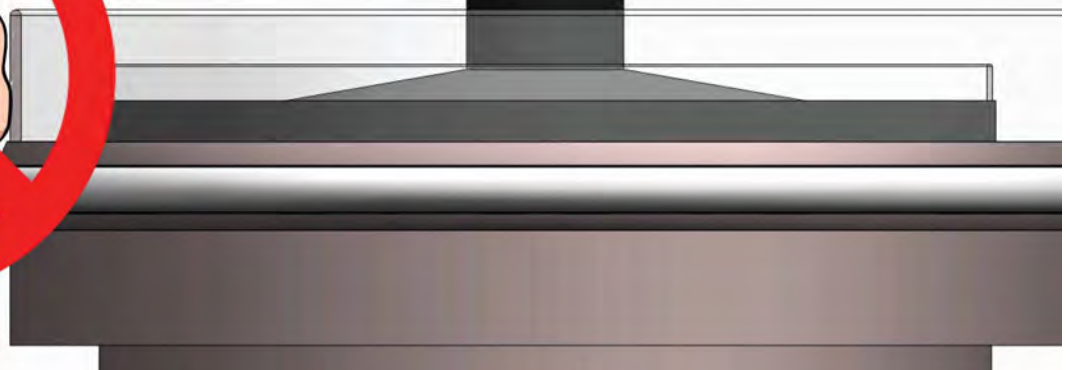
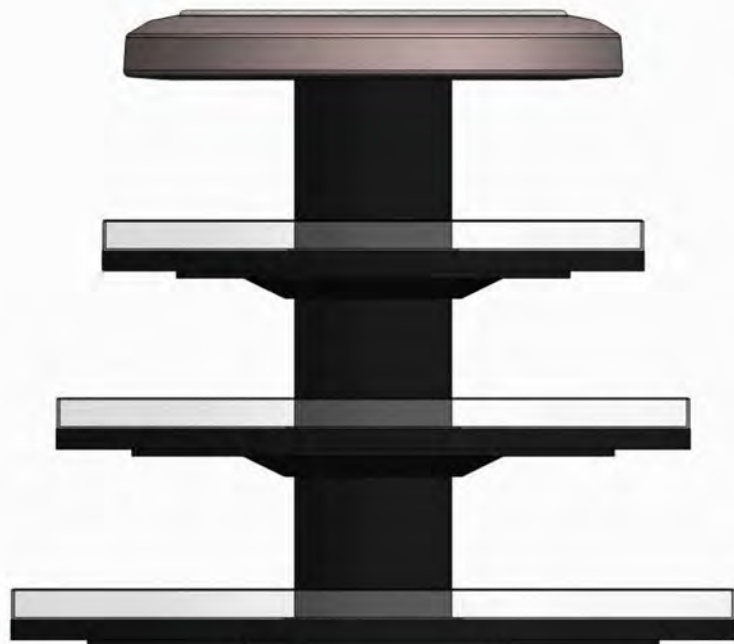
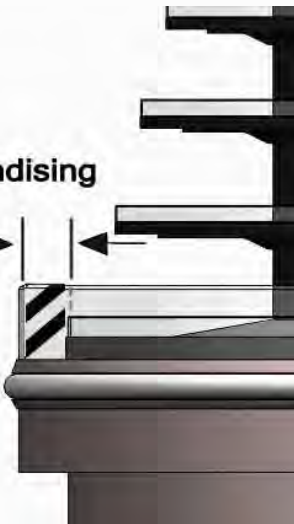

General Information

Case Description:

This Booklet specifically covers the

Following models:

Entyce TY3
 TY4

Description: The ENTyce-HOT/COLD model series are Multi-deck island merchandisers designed for medium temperature applications such as: Deli/Dairy/Beverage. The case is a combination of a remote type models, which require separate condensing unit connections as well as a self-contained model. Each self-contained model will have it's own condensing unit, factory installed beneath the display area of the case ready for operation when electrical service is connected.

Shipping Damage: All equipment should be thoroughly examined for shipping damage before and during unloading. This equipment has been carefully inspected at our factory and the carrier has assumed responsibility for safe arrival. If damaged, either apparent or concealed, claim must be made to the carrier.

Apparent Loss or Damage: If there is an obvious loss or damage, it must be noted on the freight bill or express receipt and signed by the carrier's agent; otherwise, carrier may refuse claim. The carrier will supply necessary claim forms.

Concealed Loss or Damage: When loss or damage is not apparent until after all equipment is uncrated, a claim for concealed damage is made. Make request in writing to carrier for inspection within 15 days, and retain all packaging. The carrier will supply inspection report and required claim forms.

Location/Store Conditions: The refrigerated merchandisers have been designed for use only in air conditioned stores where temperature and humidity are maintained either 75°F ambient and 55% RH. DO NOT allow air conditioning, electric fans, ovens, open doors or windows (etc.) to create air currents around the merchandiser, as this will impair its correct operation.

Shortages: Check your shipment for any possible shortages of material. If a shortage should exist and is found to be the responsibility of Hussmann Chino, notify Hussmann Chino. If such a shortage involves the carrier, notify the carrier immediately, and request an inspection. Hussmann Chino will acknowledge shortages within ten days from receipt of equipment.

Hussmann Chino Product Control: The serial number and shipping date of all equipment has been recorded in Hussmann's files for warranty and replacement part purposes. All correspondence pertaining to warranty or parts ordering must include the serial number of each piece of equipment involved, in order to provide the customer with the correct parts.

Keep this booklet with the case at all times for future reference.

HUSSMANN®/CHINO

A publication of HUSSMANN® Chino
13770 Ramona Avenue • Chino, California 91710
(909) 628-8942 FAX
(909) 590-4910
(800) 395-9229



This equipment is to be installed to comply with the applicable NEC, Federal, State, and Local Plumbing and Construction Code having jurisdiction.

Entyce Hot Cold Lifting Instructions

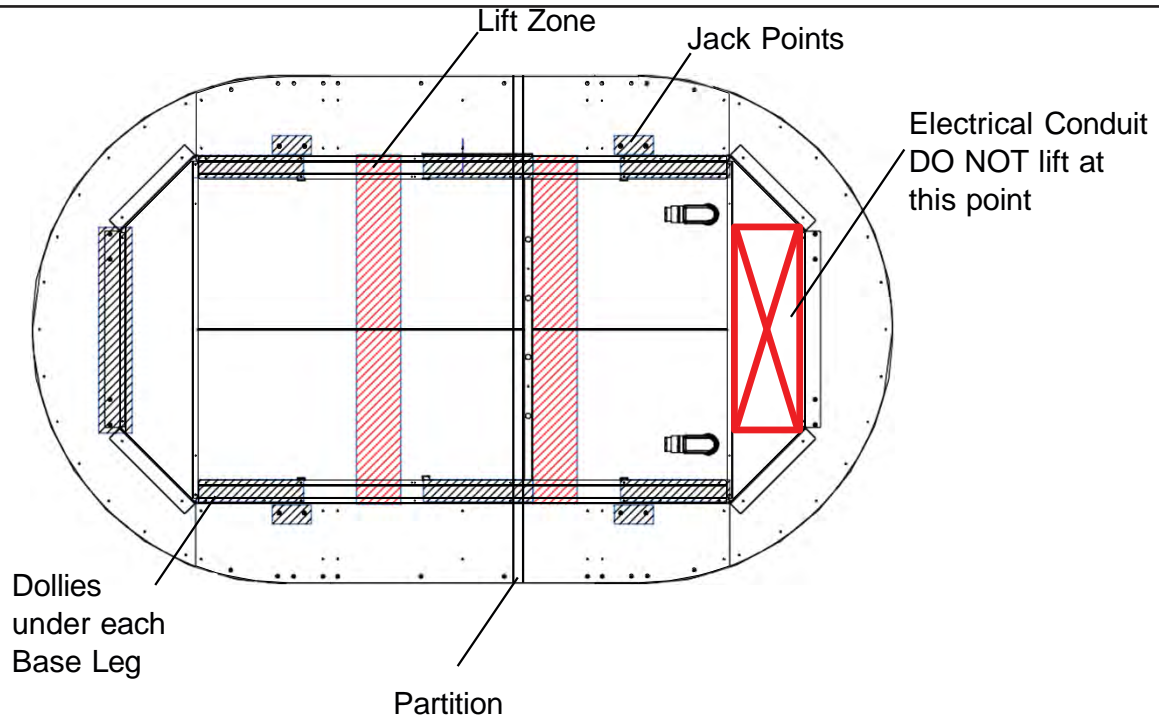

1. The Entyce can be lifted by a forklift only at the specified location in the diagram



Improper placement of forks may damage drainage piping. Use a spotter when placing forks. Make sure that piping will not be damaged. Use J-Bars or Jacks if Forks cannot be used safely

2. Remove close-offs and lower body panels before lifting with a fork. Serious damage will occur if the body panels are not removed.
 - Remove the end case lower and bottom panels first
 - Then remove the side case lower and bottom panels
 - A Phillips head screwdriver/drill is needed for lower and bottom panel removal
3. Make sure that fork spacing and width will not damage drain, piping, or electrical lines
4. Be sure that the forks are long enough to support beyond the center of the case. Check for proper balance before moving. A minimum fork length of 36" is recommended for 68" wide cases
5. The Entyce can be raised at one end with a forklift to allow the placement of rollers or dollies. See figure on page 13 for J-bar and jacking instructions
6. Never drag or push the Entyce by ANY COMPONENT including ANY GLASS COMPONENT. This will result in damage to the base, and possibly damage to other components
7. Evenly support the entire base structure on rollers or dollies before attempting to move. Each Base Leg must have its own dolly to properly support the case.

Installation

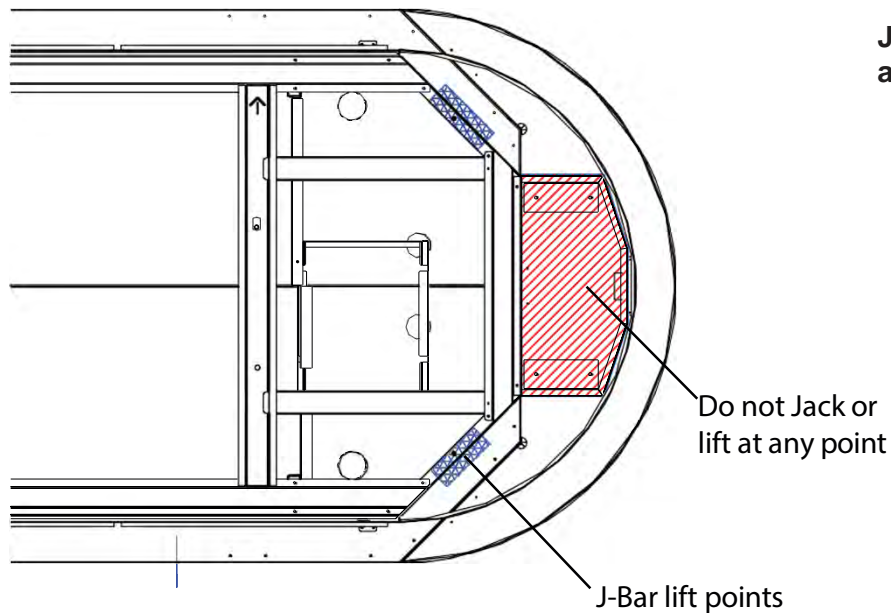

J-Bar lift points typical for Cold and Hot section of case.

8. If using J-Bars, use the specified jacking points to raise the case
 - Raise one side of the case first.
 - Use as many J-Bars as possible to lift from the base channels
 - A minimum of 2 J-Bars is required
 - Place Dollies and chock wheels before lifting the other side. Be sure that the dollies are evenly spaced to carry to weight of the case

9. If using Floor-jacks or Bottle-jacks, use the recommended lifting points located at the underside of the case
 - These points will be visible channels
 - Lift simultaneously to place dollies or rollers

Close-Off Removal

Close-off removal for Entyce case Typical

Step 1

Slide bottom of close-off in upward motion to remove from tabs.



Step 2

Pull Close-off in outward then downward motion to completely remove side panel close-off



Step 3

Once side panel close-off has been removed from case four screws will be visible which fasten the round close-off to the case. Remove the four screws 2 on each end to remove the end close-off.



Cold Case Condensate Access Vent.

Self Contained case has 2 vented panels on each side of the case for proper circulation through condensing unit area.

See illustrations below for access to panels.

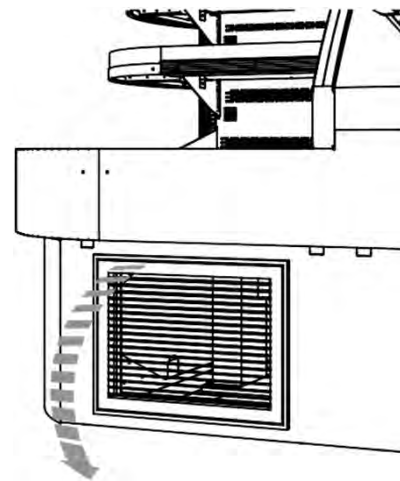

Hot Case Heating Control Panels

Hot case section has an access panels on the side of the case for access to heating controls for shelves and overhead heating.

See illustrations below for access to panel.

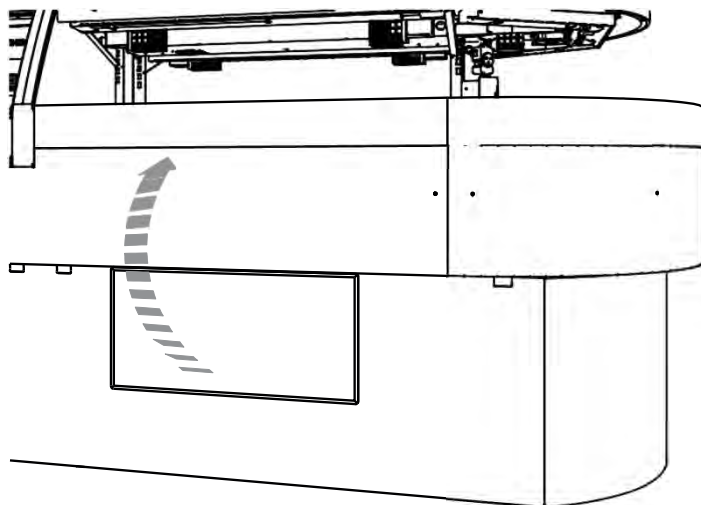

TY3 4X4E-S Cold Section

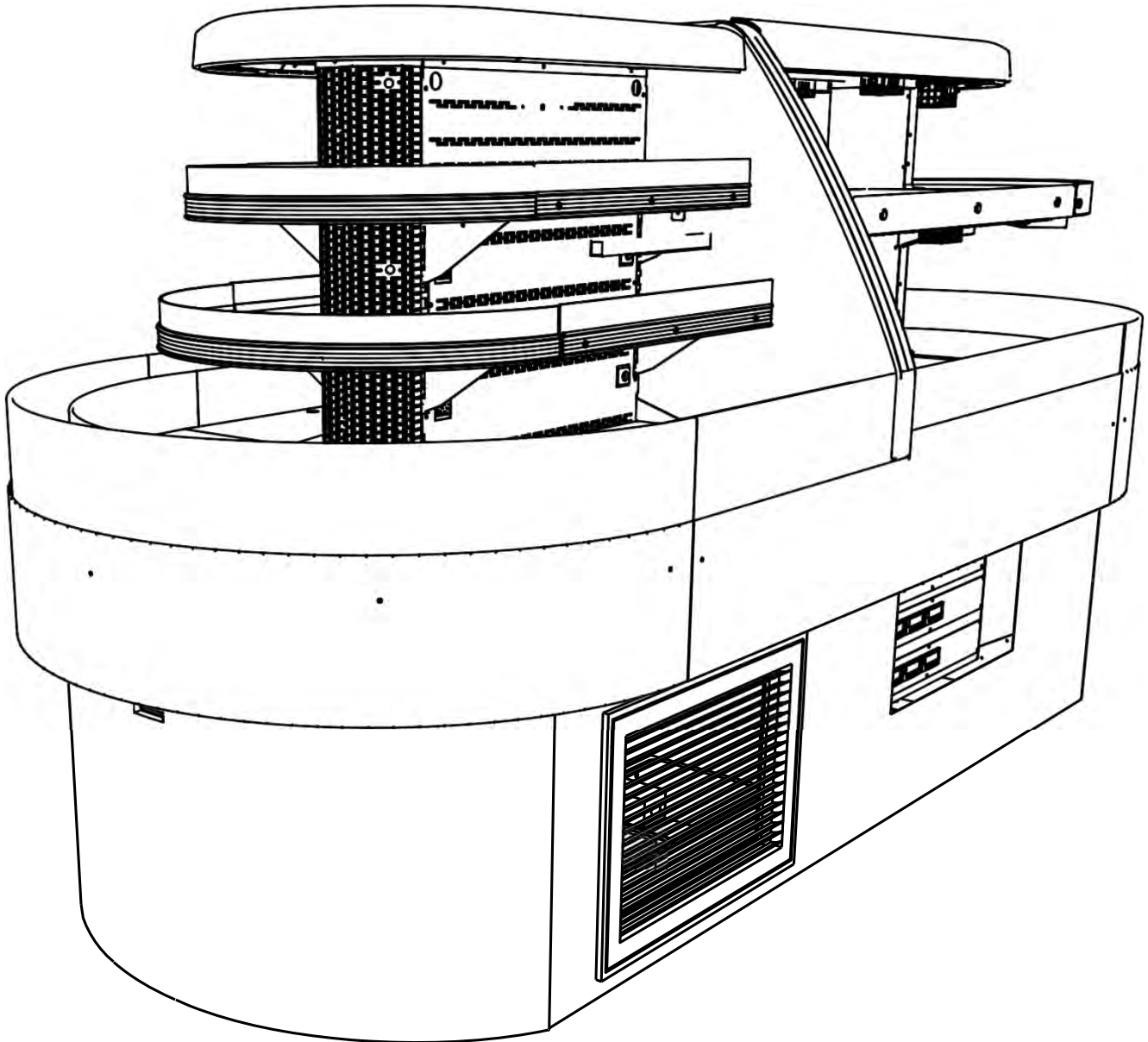

Cold Section Start up

1. Apply power to the merchandiser.
2. Wait for the self check to complete.
 - During the self check, each LED flashes for one second, then all LEDs turn on for two seconds.
 - If the LEDs do not flash, make sure the adjustment knob is not in the Off position.
3. The compressor will start for 30 seconds after the self check is complete.
 - The merchandiser temperature displays at startup
 - An initial defrost occurs two hours after startup
 - The compressor runs until it reaches its setpoint temperature until defrost.
4. Refrigeration: The compressor will continue to cycle on-and-off normal until defrost occurs.
5. Defrost: Defrost is scheduled to occur every 8 hours, or earlier if triggered by a demand defrost.
 - Defrost continues for a set time period, or until the defrost termination temperature is reached.
 - During defrost the display shows the initial defrost temperature (temperature at start of defrost)
 - This initial defrost temperature is displayed for the set time period (even if refrigeration mode resumes before the end of this period).
6. If power is interrupted, the process will start over at step 1.

Operation

1. **DO NOT LOAD PRODUCT** until case reaches desired operating temperature (approx. 4 hrs).
2. Food Product temperature must be below 38°F when loading a case. Case is not designed to chill food.
3. Check shelf loading. Overstock will reduce case performance and operation.
4. **DO NOT** block discharge or return air. **DO NOT** display packages over the air inlet located at the front of the lowest deck. This restricts airflow, and will result in warmer temperature in the case.
5. **DO NOT** display more than 150 pounds of product per shelf. Additional weight will damage the shelves.

Temperature Adjustment

See Controller Manual for details

Alarms and codes

See Controller Manual for details

Installation Store Conditions

- Case is designed to operate at temperatures 80°F and or below 55% relative humidity. Case must be kept in that environment to ensure case performance and product safety.

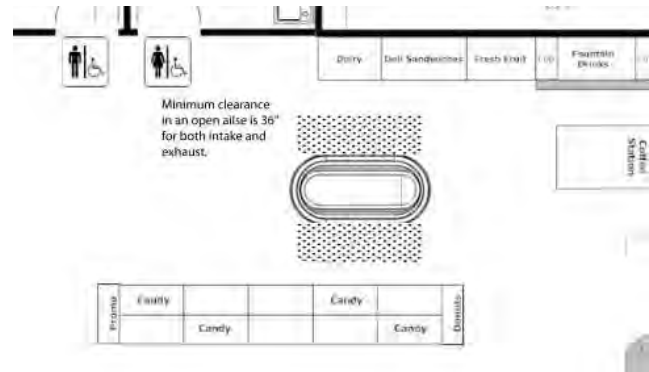

For prompt service when contacting the factory regarding problems, be sure to have the Case Model and Serial Number handy. This information is on a plate located on itself.

www.husmann.com (909) 590-4910 (800) 395-9229

HUSSMANN®

Installation

Store Conditions

- Case is designed to operate at temperatures at either 75°F at 55% relative humidity or 80°F and or below 55% relative humidity. Case must be kept in that environment to ensure case performance and product safety.
- Do not position the case near an HVAC vent.
- Do not position the case near an entrance door. Outside ambient conditions may have an adverse affect on the refrigeration performance, a minimum of 15' clearance is required from doors.
- Do not position the case tight against a ceiling or soffit. A minimum clearance 10" above the unit is required for proper compressor discharge air flow.
- Do not block case front panel vent (supplies critical intake air flow to the compressor)



DANGER

**BEFORE SERVICING
ALWAYS DISCONNECT ELECTRICAL
POWER AT THE MAIN DISCONNECT
WHEN SERVICING OR REPLACING ANY**

Uncrating the Stand

Place the fixture as close to its permanent position as possible. Remove the top of the crate. Detach the walls from each other and remove from the skid. Unbolt the case from the skid. The fixture can now be lifted off the crate skid. **Lift only at base of stand!**

Condensate Pan Setup

There is one condensate evaporator pan on this unit. The drain pipe from the case feed into the condensate pan, once water levels are high enough in the condensate pan the float switch level is triggered which will then trigger the heater to raise temperature therefore evaporating the water into the case airstream.

WARNING!

Do NOT apply thread sealer to ABS P-Trap.



Do Not Install the Vented Panels of the self-contained model against a wall or other storage fixture.

Located in the lower front and rear of the self-contained models are vented panels. These panels allow air circulation to the condensing unit. Blocking or restricting air circulation through these panels can cause poor performance and damage the refrigeration system.

Exterior Loading

These models have not been structurally designed to support excessive external loading. **Do not walk on their tops;** This could cause serious personal injury and damage to the fixture.



**ATTENTION
INSTALLER**

It is the contractor's responsibility to install case(s) according to local construction and health codes.

Leveling

A LEVEL CASE IS NECESSARY TO INSURE PROPER OPERATION AND WATER DRAINAGE.

Note: To avoid removing concrete flooring, begin lineup leveling from the highest point of the store floor.

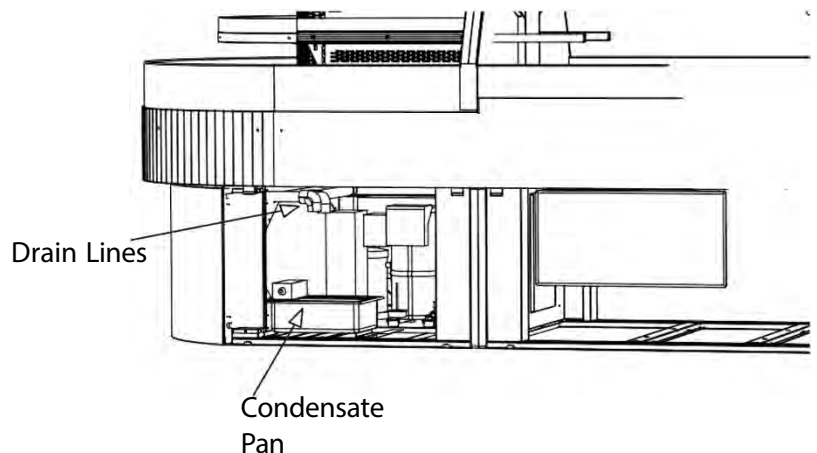

Electrical

STANDARD CASE WIRE COLOR CODE CODIGO DE COLORES DE LOS ALAMBRES PARA LAS VITRINAS ESTANDAR CODE COULEUR POUR FILS DE BOUTIER NORMALISE		
COLOR DESCRIPTION	DESCRIPCION	DESCRIPTION
GROUND	TIERRA MASA	MASSE
ANTI-SWEAT	ANTICONDENSACION	ANTI-SUITEMENT
LIGHTS	LUCES	ECLAIRAGE
RECEPTACLES	ENCHUFES	PRISE DE COURANT
T-STAT/SOLENOID 230VAC	TERMOSTATO/SOLENOIDE (230VAC)	SOUPAPE A SOLENOID (230 VAC)
T-STAT/SOLENOID 115VAC	TERMOSTATO/SOLENOIDE (115VAC)	SOUPAPE A SOLENOID (115 VAC)
T-STAT/SOLENOID 24VAC	TERMOSTATO/SOLENOIDE (24VAC)	SOUPAPE A SOLENOID (24 VAC)
FAN MOTORS	VENTILADORES	VENTILATEUR
BLUE CONDENSING UNIT	UNIDAD DE CONDENSACION	UNITE DE CONDENSATION

USE COPPER CONDUCTORS ONLY
UTILISEZ LES CONDUCTEURS DE CUIVRE SEULEMENT
UTILICE LOS CONDUCTORES DE COBRE SOLAMENTE
 430-01-0338 R101003

CASE MUST BE GROUNDED

NOTE: Refer to label affixed to case to determine the actual configuration as checked in the "TYPE INSTALLED" boxes.

Standard lighting for all refrigerated models will be full length LED Lights located within the case at the top.

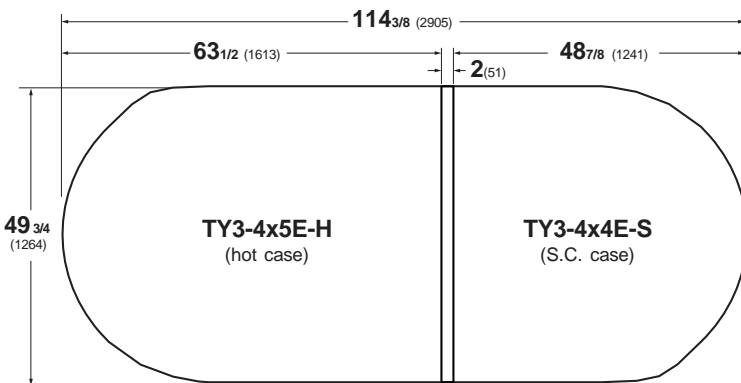

Field Wiring and Serial Plate Amperage

Field Wiring must be sized for component amperes printed on the serial plate. Actual ampere draw may be less than specified. Field wiring from the refrigeration control panel to the merchandisers is required for refrigeration thermostats. Case amperes are listed on the wiring diagram, but always check the serial plate.



DANGER

BEFORE SERVICING
ALWAYS DISCONNECT ELECTRICAL
POWER AT THE MAIN DISCONNECT
WHEN SERVICING OR REPLACING ANY
ELECTRICAL COMPONENT.

This includes (but not limited to) Fans, Heaters
Thermostats, and Lights.

TY3-4-H Self-Service Hot End

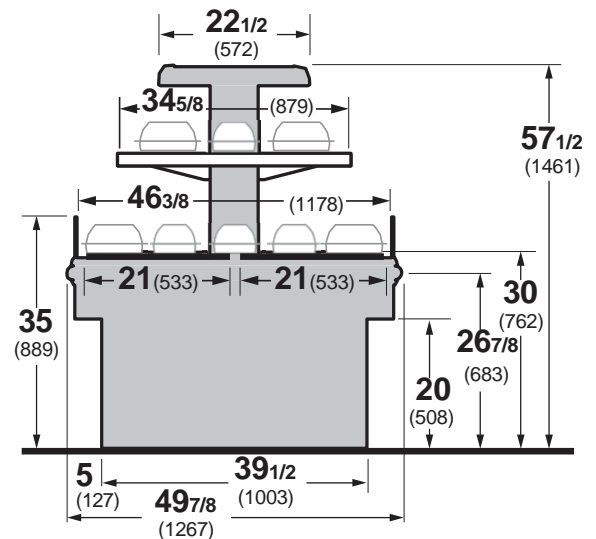

Wiring Diagram Index

TY3-3X4.5E-S	4.5'	3129188
TY3ECRC-3X4.5E-S	4.5'	3141053
TY3EC-3X5.5E-S	5.5'	3129189
TY3ECRC-3X5.5E-S	5.5'	3138635
TY3-4X4E-S HARRIS TEETER ONLY	4'	3129190
TY3-4X4E-S W/PARKING LOT	4'	3129191
TY3-3X4.5-S W/XR75 CTRL	4.5'	3157238
TY3EC-3X4.5E-S W/XR75 CTRL	4.5'	3168381
TY3-4X4E-S W/XR75 CTRL	4'	3160998

CIRCUIT #1

Q1	Q2	Q3	Q4	Q5	Q6	Q7	Q8	Q9	Q10	Q11	Q12	Q13	Q14	Q15	Q16	Q17	Q18	Q19	Q20	Q21	Q22	Q23	Q24	Q25	Q26	Q27	Q28	Q29	Q30	Q31	Q32	Q33	Q34	Q35	Q36	Q37	Q38	Q39	Q40	Q41	Q42	Q43	Q44	Q45	Q46	Q47	Q48	Q49	Q50	Q51	Q52	Q53	Q54	Q55	Q56	Q57	Q58	Q59	Q60	Q61	Q62	Q63	Q64	Q65	Q66	Q67	Q68	Q69	Q70	Q71	Q72	Q73	Q74	Q75	Q76	Q77	Q78	Q79	Q80	Q81	Q82	Q83	Q84	Q85	Q86	Q87	Q88	Q89	Q90	Q91	Q92	Q93	Q94	Q95	Q96	Q97	Q98	Q99	Q100
----	----	----	----	----	----	----	----	----	-----	-----	-----	-----	-----	-----	-----	-----	-----	-----	-----	-----	-----	-----	-----	-----	-----	-----	-----	-----	-----	-----	-----	-----	-----	-----	-----	-----	-----	-----	-----	-----	-----	-----	-----	-----	-----	-----	-----	-----	-----	-----	-----	-----	-----	-----	-----	-----	-----	-----	-----	-----	-----	-----	-----	-----	-----	-----	-----	-----	-----	-----	-----	-----	-----	-----	-----	-----	-----	-----	-----	-----	-----	-----	-----	-----	-----	-----	-----	-----	-----	-----	-----	-----	-----	-----	-----	-----	-----	-----	------

REV	ECN	DATE	REVISION DESCRIPTION	REV BY	CHKD BY	APPR BY
A	ECN-000-0011337	7-22-20	RELEASED TO PRODUCTION	CB	CB	CB
B	ECN-000-0016612	4-1-22	NEW LIGHTS	AL	CB	CB

LIGHT CIRCUIT
0.56A 62.4W @ 120V

CANOPY

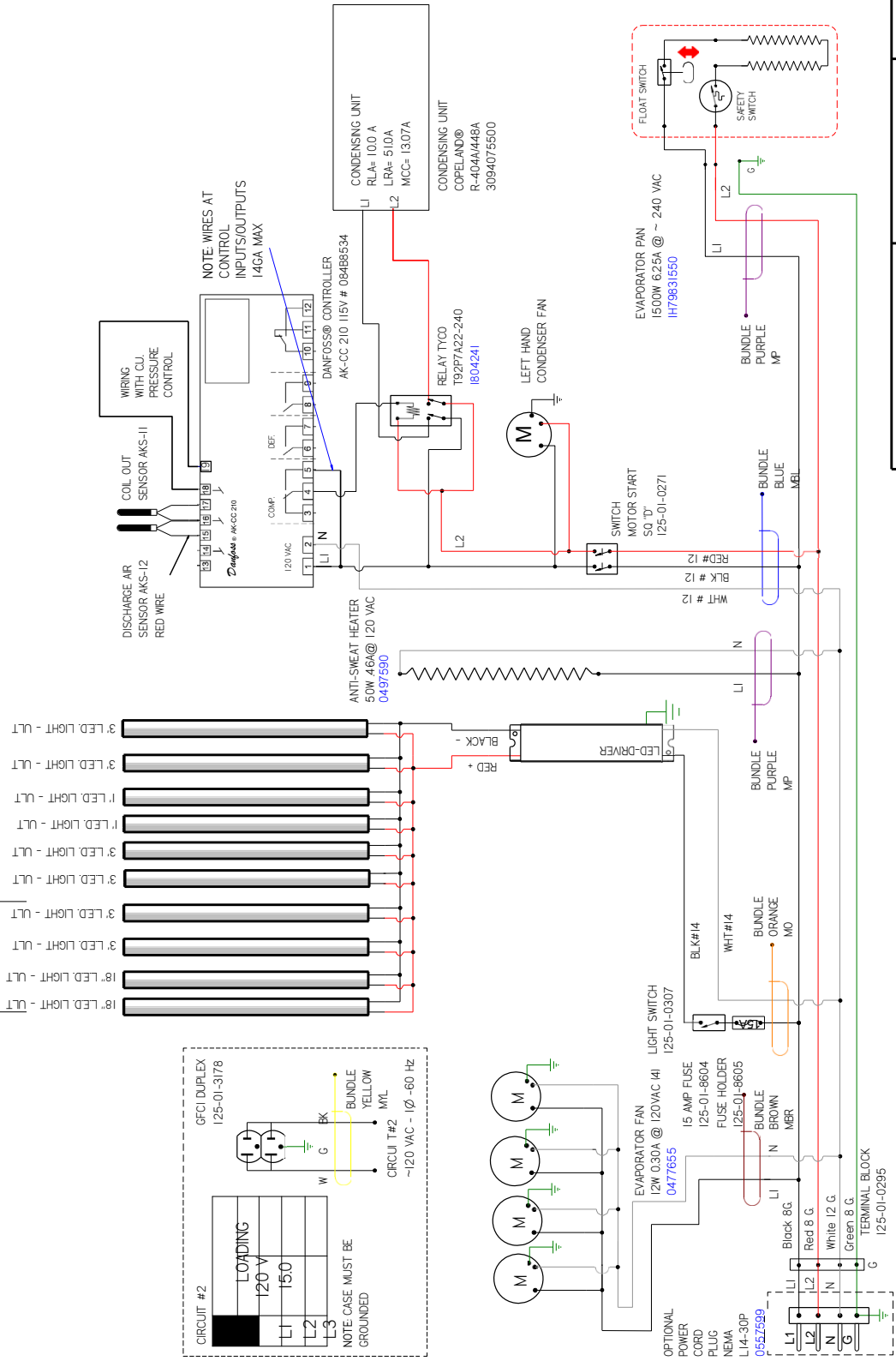

- NOTES:
1. PRINTED DOCUMENT REQUIRED SETTING: ALL COLORS BLACK & WHITE
 2. CASE & ANY REMOVABLE PANEL WITH ELECTRICAL PARTS MUST BE GROUNDED.
 3. WHEN PASSING WIRES THROUGH METAL HOLES A GROMMET MUST BE USED

HUSSMANN
DIAGRAM-TY3-3X4.5 E-S
3129188
 SHEET 1 OF 1

FACTORY 14GA WIRE
 - FACTORY LOGGA WIRE
 - FIELD WIRE
 - - - - -
 DO NOT SCALE DRAWING

UL COLOR CODES / ABBREVIATIONS
 RED = RD
 BLACK = BK
 BLUE = BL
 YELLOW = YL
 GRAY = GY
 WHITE = WT
 GREEN = GN
 BROWN = BN
 ORANGE = OR
 PURPLE = MP
 VIOLET = VT

CIRCUIT #1
DWG
Z08Y Z40V
L17A 197
L143 172

REV	ECN	DATE	REVISION DESCRIPTION	REV BY	CHKD BY	APPR BY
A	ECN-COD-0011858	1-12-21	RELEASED TO PRODUCTION	CB	CB	CB
B	ECN-COD-0012734	3-9-21	CHANGED COND. UNIT	CB	CB	CB
C	ECN-COD-0015612	4-4-22	NEW LIGHTS	AL	CB	CB

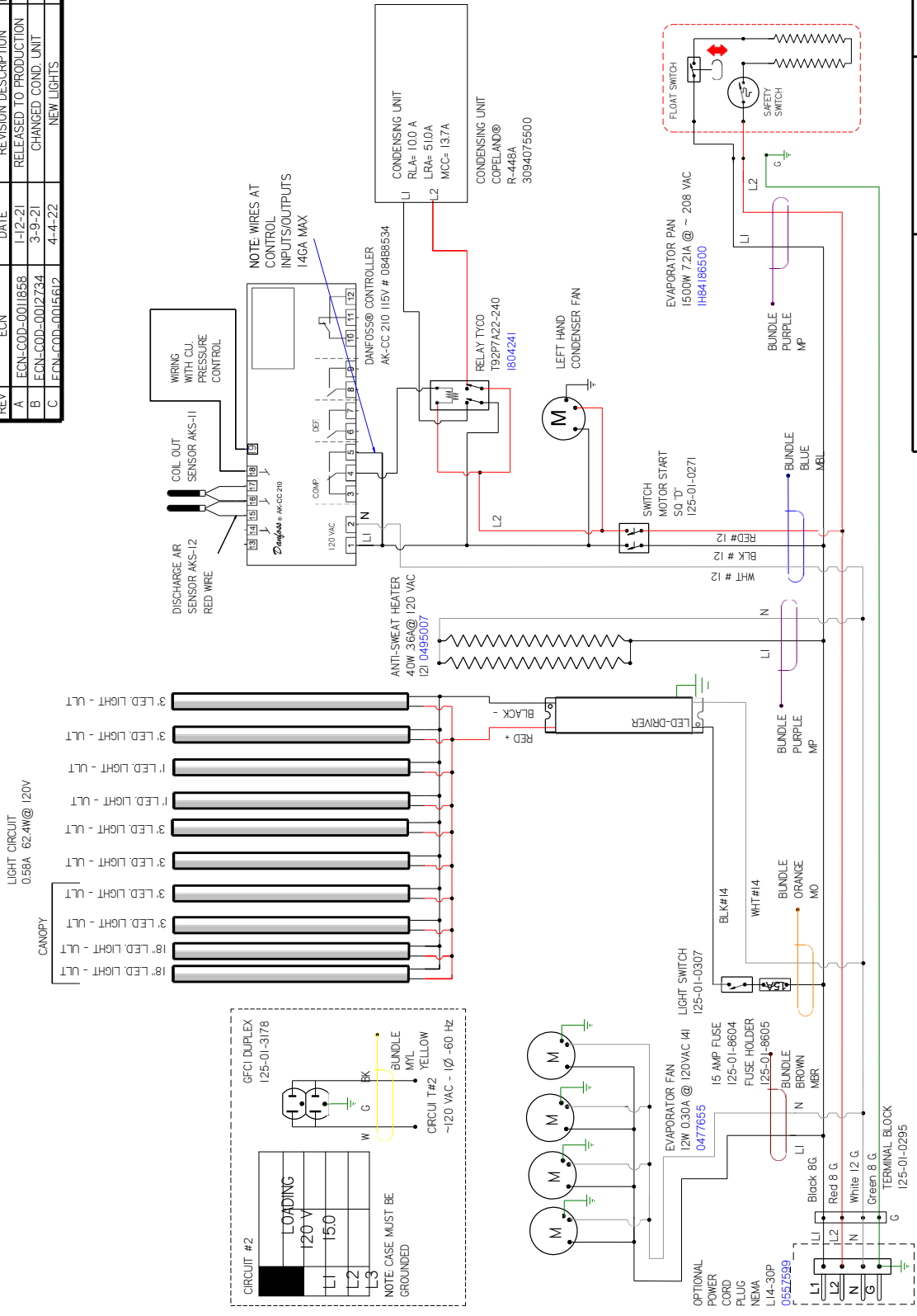

HUSSMANN

DIAGRAM-
TY3ECRC-3X4.5E-
S

3141053

FACTORY 14GA WIRE
- FACTORY LOGA WIRE
- FIELD WIRE - - -
DO NOT SCALE DRAWING
SHEET 1 OF 1

UL COLOR CODES / ABBREVIATIONS
 RED = RD
 BLACK = BK
 BLUE = BL
 YELLOW = YL
 GRAY = GR
 WHITE = WT
 GREEN = GN
 BROWN = BN
 ORANGE = OR
 PURPLE = VP
 VIOLET = VT

- NOTES:
1. PRINTED DOCUMENT REQUIRED SETTING: ALL COLORS BLACK & WHITE
 2. CASE & ANY REMOVABLE PANEL WITH ELECTRICAL PARTS MUST BE GROUNDED.
 3. WHEN PASSING WIRES THROUGH METAL HOLES A GROMMET MUST BE USED

CIRCUIT #1
LOADING

Z08V	Z40V
L1	L2
L3	L4
L5	L6
L7	L8
L9	L10
L11	L12
L13	L14
L15	L16
L17	L18
L19	L20

2

SHELF LIGHTS

CANDOPY LIGHTS



LIGHT CIRCUIT
0.71A 76.2W @ 120V

REV	ECN	DATE	REVISION DESCRIPTION	REV BY	CHKD BY	APPR BY
A	ECN-C00-0011337	7-22-20	RELEASED TO PRODUCTION	CB	CB	CB
B	ECN-C00-0015612	04-04-22	NEW LIGHTS	AL	CB	CB

REVISION HISTORY

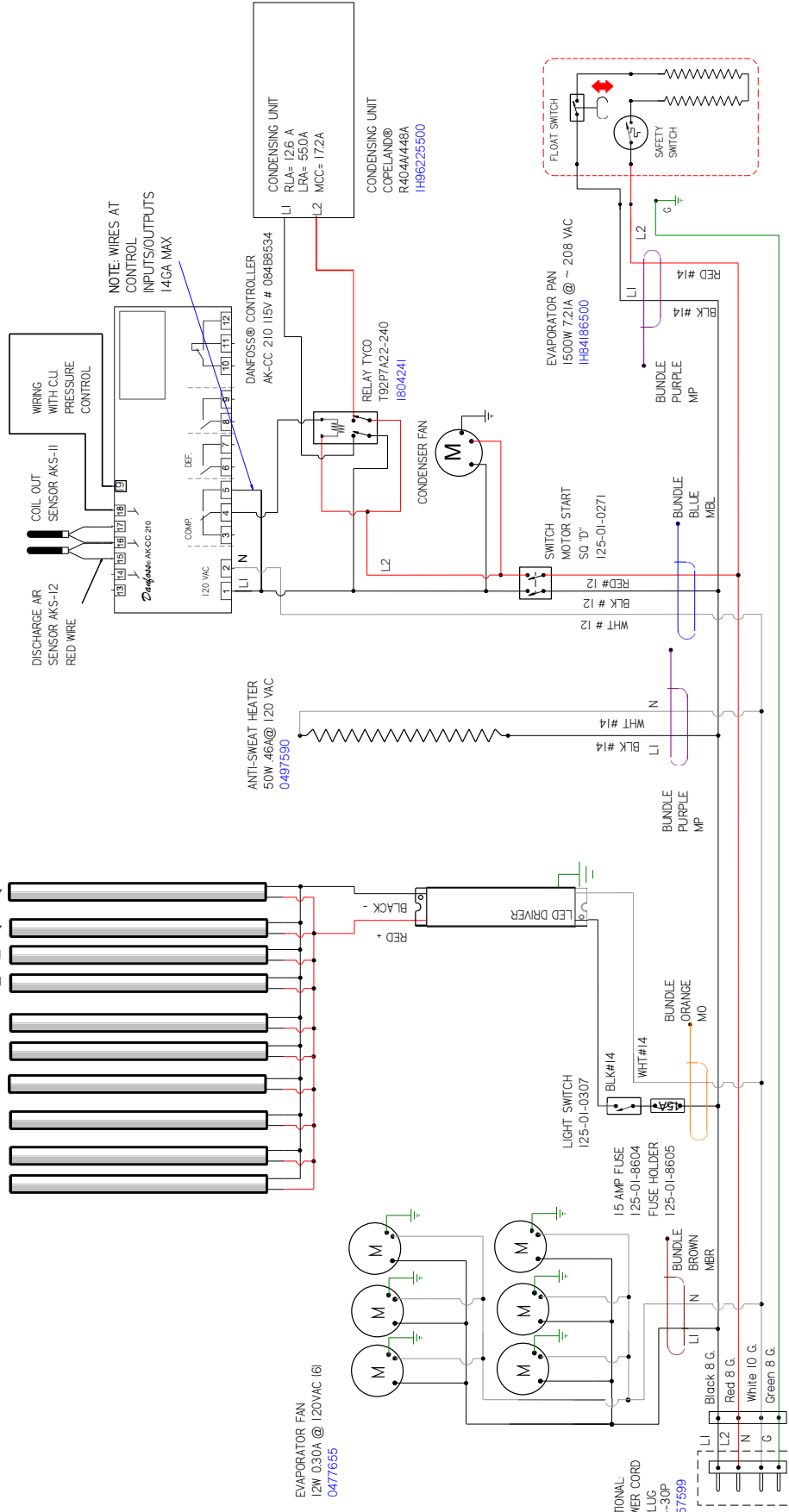

TERMINAL BLOCK
2H07970550

HUSSMANN
DIAGRAM-TY3-
3X5.5 E-S
3129189

FACTORY 14GA WIRE
FACTORY LOGA WIRE
FIELD WIRE
DO NOT SCALE DRAWING
SHEET 1 OF 1

UL COLOR CODES / ABBREVIATIONS
WHITE = WT
GREEN = GN
BROWN = BN
ORANGE = OR
YELLOW = YL
GRAY = GR
RED = RD
BLACK = BK
BLUE = BL
PURPLE = MP
OR VIOLET = VT

- NOTES:
1. PRINTED DOCUMENT REQUIRED SETTING: ALL COLORS BLACK & WHITE
 2. CASE & ANY REMOVABLE PANEL WITH ELECTRICAL PARTS MUST BE GROUNDED.
 3. WHEN PASSING WIRES THROUGH METAL HOLES A GROMMET MUST BE USED

CIRCUIT #1
LOADING
208 24
L1 166 191
L2 149 142

LIGHT CIRCUIT
0.34A 36.8W @ 120V
CANOPY

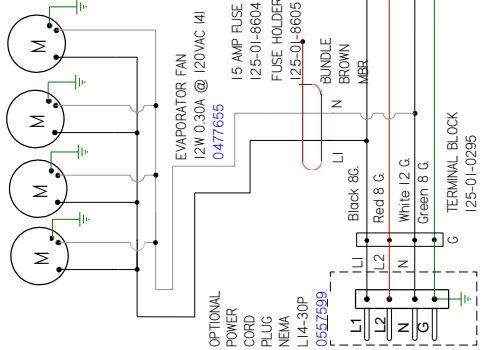
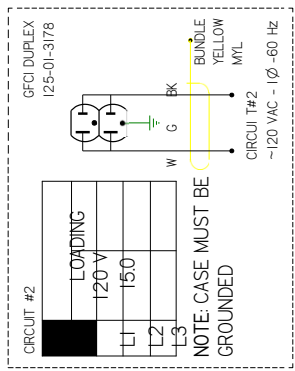

REV	ECN	DATE	REVISION DESCRIPTION	REV BY	CHKD BY	APPR BY
A	ECN-C00-0011337	7-22-20	RELEASED TO PRODUCTION	CB	CB	CB
B	ECN-C00-0015612	4-1-22	NEW LIGHTS	AL	CB	CB

REVISION HISTORY

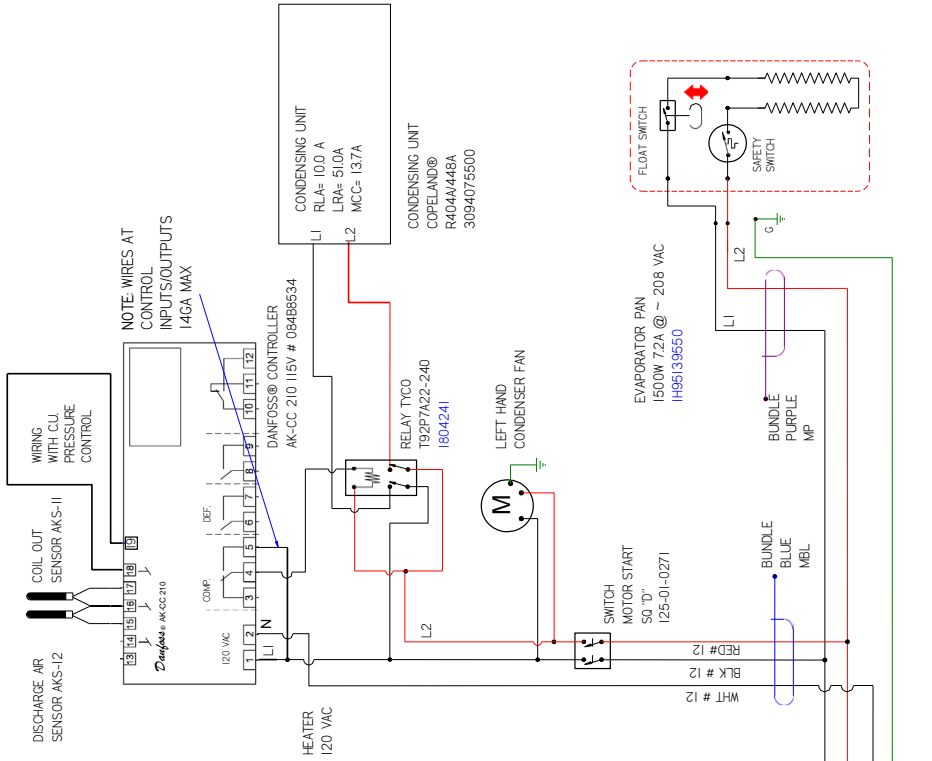

HUSSMANN
DIAGRAM-TY3-4X4E-S(IHT)

FACTORY 14GA WIRE
- FACTORY LOGA WIRE
- - - FIELD WIRE
DO NOT SCALE DRAWING
SHEET 1 OF 1

UL COLOR CODES / ABBREVIATIONS
RED = RD
BLACK = BK
BLUE = BL
YELLOW = YL
GRAY = GR
WHITE = WT
GREEN = GN
BROWN = BN
ORANGE = OR
PURPLE = VP
VIOLET = VT

- NOTES:
1. PRINTED DOCUMENT REQUIRED SETTING: ALL COLORS BLACK & WHITE
 2. CASE & ANY REMOVABLE PANEL WITH ELECTRICAL PARTS MUST BE GROUNDED.
 3. WHEN PASSING WIRES THROUGH METAL HOLES A GROMMET MUST BE USED

REV	ECN	DATE	REVISION DESCRIPTION	REV BY	CHKD BY	APPR BY
A	ECN-COD-0011337	7-22-20	RELEASED TO PRODUCTION	CB	CB	CB
B	ECN-COD-0011846	10-15-20	REV. EVAP PAN AMPS & VOLTS	CB	CB	CB
C	ECN-COD-0015612	4-1-22	NEW LIGHTS	AL	CB	CB

CIRCUIT #1	LOADING
	208 24
L1	18.6 21.5
L2	V17.0 19.6

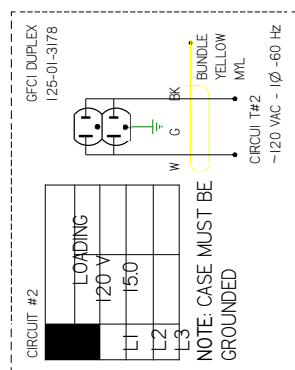
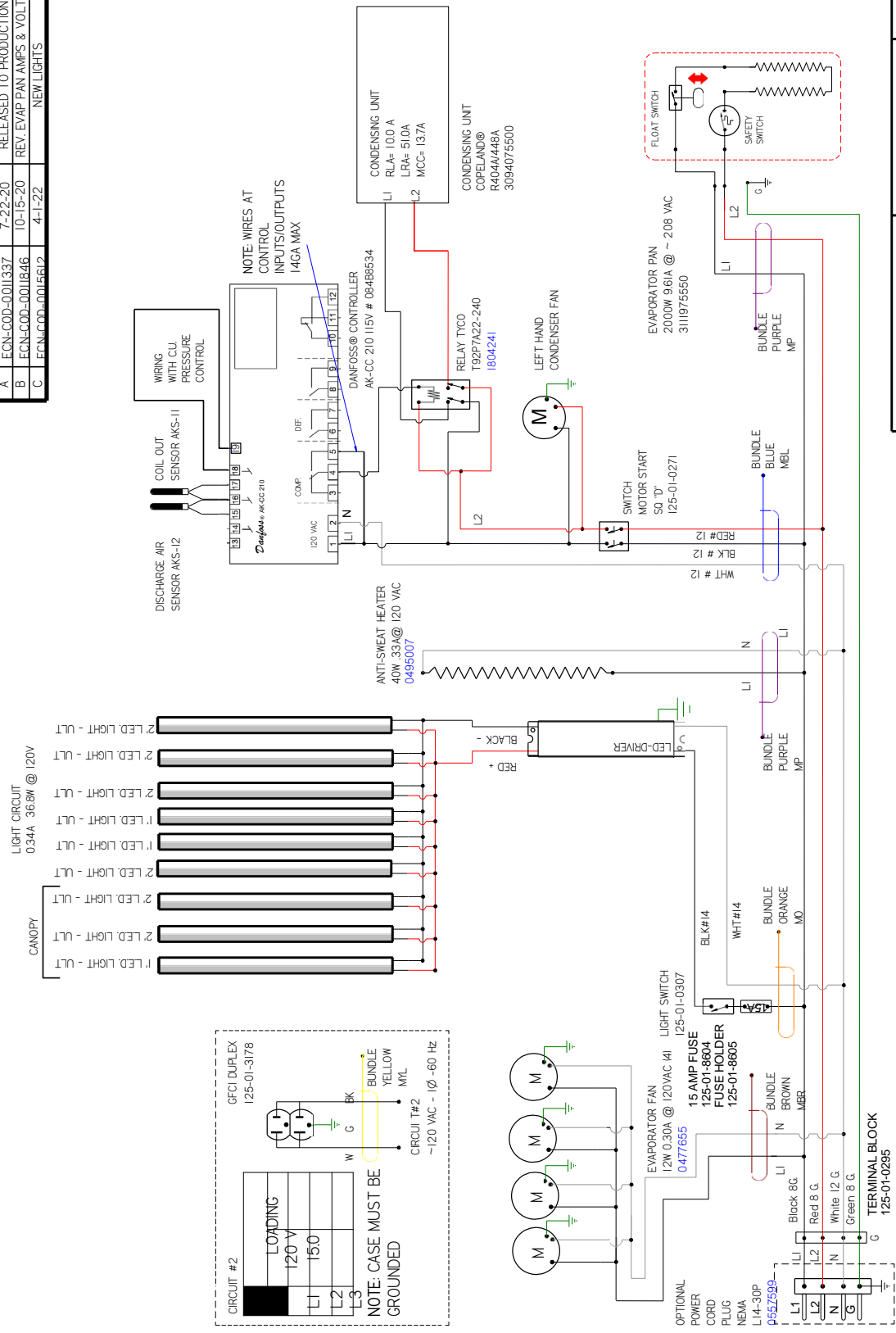

- NOTES:**
1. PRINTED DOCUMENT REQUIRED SETTING: ALL COLORS BLACK & WHITE
 2. CASE & ANY REMOVABLE PANEL WITH ELECTRICAL PARTS MUST BE GROUNDED.
 3. WHEN PASSING WIRES THROUGH METAL HOLES A GROMMET MUST BE USED

HUSSMANN
DIAGRAM-TY3-4X4E-S

FACTORY 14GA WIRE
 -FACTORY LOGA WIRE
 -FIELD WIRE
 -DO NOT SCALE DRAWING

UL COLOR CODES / ABBREVIATIONS
 RED = RD
 BLACK = BK
 BLUE = BL
 YELLOW = YL
 GRAY = GY
 WHITE = WT
 GREEN = GN
 BROWN = BN
 ORANGE = OR
 VIOLET = VT

SHEET 1 OF 1

CIRCUIT #1	DWG	240V	240V	100V	100V	141	100

LIGHT CIRCUIT
0.58A 62.4W @ 120V

REVISION HISTORY						
REV	ECN	DATE	REVISION DESCRIPTION	REV BY	CHKD BY	APPR BY
A	ECN-COD-001450Z	10-28-21	RELEASED TO PRODUCTION	CB	CB	CB
B	ECN-COD-0015256	3-9-22	NEW LIGHTS	AL	CB	CB

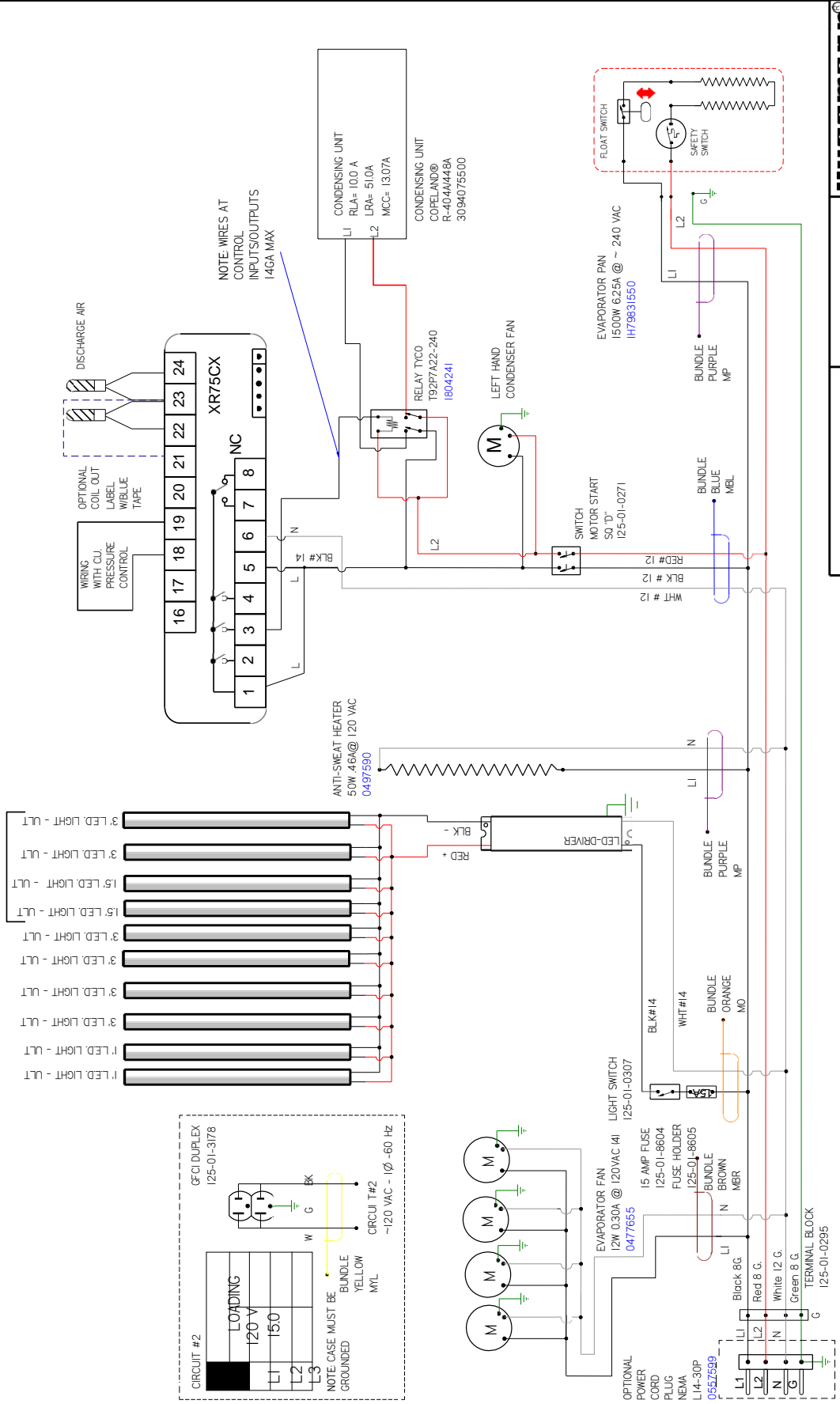

- NOTES:
1. PRINTED DOCUMENT REQUIRED SETTING: ALL COLORS BLACK & WHITE
 2. CASE & ANY REMOVABLE PANEL WITH ELECTRICAL PARTS MUST BE GROUNDED.
 3. WHEN PASSING WIRES THROUGH METAL HOLES A GROMMET MUST BE USED

HUSSMANN

DIAGRAM-TY3-
3X4.5 E-S WXR75
CTLR

FACTORY 14GA WIRE
-FACTORY LOGGA WIRE
-FIELD WIRE
-DO NOT SCALE DRAWING

SHEET 1 OF 1

3157238

CIRCUIT #1	LOADING
208	24
L1	18.6
L2	V17.0

REV	ECN	DATE	REVISION DESCRIPTION	REV BY	CHKD BY	APPR BY
B	ECN-COD=0015256	3-7-22	NEW LIGHTS	AL	CB	CB
C	ECN-COD=0016836	10-10-22	ADDED OPTIONAL PROBE	AL	CB	CB

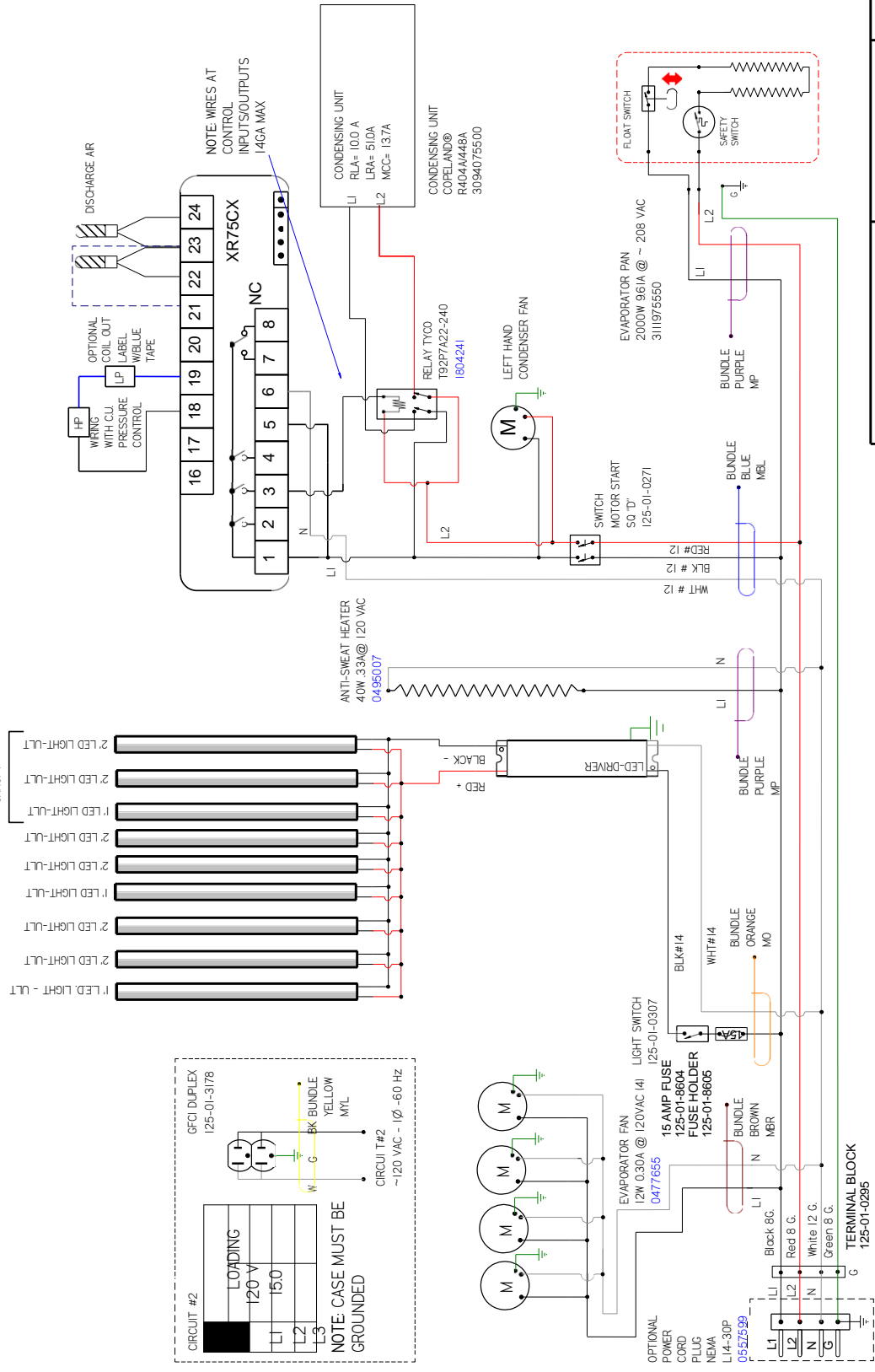

LIGHT CIRCUIT
0.34A 36.8W @ 120V

CANOPY

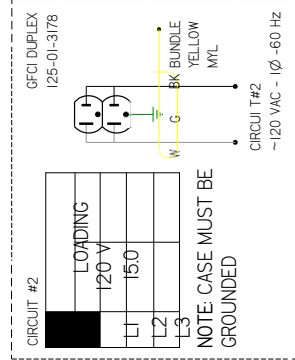

HUSSMANN
DIAGRAM-TY3-
4X4E- SXR75 CTLR

FACTORY 14GA WIRE
-FACTORY 10GA WIRE
-FIELD WIRE -
-DO NOT SCALE DRAWING

UL COLOR CODES / ABBREVIATIONS:
 MAROON =
 MMR ORANGE =
 MO PINK = MPI
 PURPLE = MP
 RED = MR
 LIGHT BLUE = MLB
 YELLOW = MYL
 WHITE = WT
 GREEN = GN
 BROWN = BN
 ORANGE =
 OR VIOLET =
 VT
 CY

3160998
SHEET 1 OF 1

- NOTES:
1. PRINTED DOCUMENT REQUIRED SETTING: ALL COLORS BLACK & WHITE
 2. CASE & ANY REMOVABLE PANEL WITH ELECTRICAL PARTS MUST BE GROUNDED.
 3. WHEN PASSING WIRES THROUGH METAL HOLES A GROMMET MUST BE USED



SELF-SERVICE DELI

HUSSMANN - TY3-3 E-END SELF-CONTAINED (CHINO)

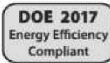

Husmann refrigerated merchandisers configured for sale for use in the United States meet or surpass the requirements of the DOE 2017 energy efficiency standards.

REVISION DATE

07/09/20

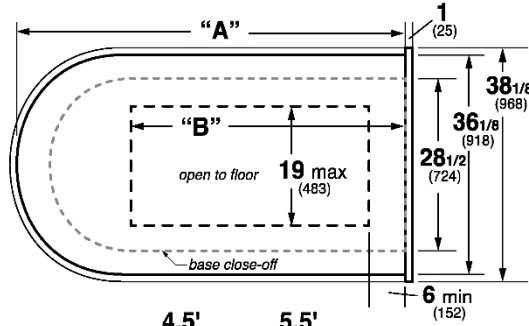
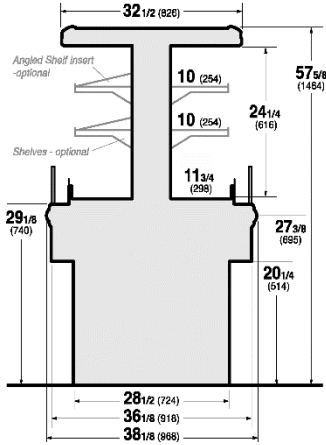
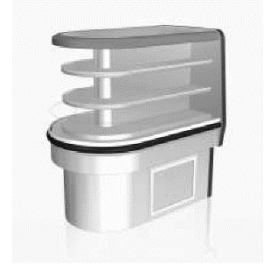

	4.5'	5.5'
"A"	54 1/2 (1384)	66 1/2 (1689)
"B"	34 (864) max	46 (1168) max

REFRIGERATION DATA:

CASE LENGTHS	CASE USAGE	CONVENTIONAL CAPACITY *** (BTU/HR/FT)	AVERAGE DISCHARGE AIR** (*F) (SEE SETPOINTS BELOW)	VELOCITY (FT/MIN)
4.5E, 5.5E	DELI	1750	28~32	125~175

**FRONT DISCHARGE AIR MEASURED INSIDE AIR CURTAIN HONEYCOMB

***REFRIGERATION NOTES:

- 1) CAPACITY FOR REFERENCE ONLY
- 2) APPROVED UP TO TYPE II CONDITIONS (80°F/55% RH)
- 3) DEFROST FOR IS BASED ON TERMINATION TEMP, WHICH UNDER NORMAL CIRCUMSTANCES, IS SHORTER THAN FAILSAFE TIME.

REFRIGERATION DATA CONTINUED:

ELEC. THERMOSTAT / AIR SENSOR SETTINGS			DEFROST TYPE	TIME (MIN)	DEFROST FREQUENCY (#/DAY)	TERM. TEMP (*F) COIL ONLY	DRIP TIME	DEFROST WATER (LBS/DAY/FT)
USAGE	SET POINT (*F)	DIFFERENTIAL (*F)						
DELI	23	10	OFF TIME	40	6	48	N/A	3.8

END PANEL WIDTH KEY		
# OF END PNLS	END PNL WIDTH (IN.)	TOTAL ADDED LENGTH (IN.)
1	1.125	1.125
2	1.125	2.25

ELECTRICAL DATA:

STANDARD FANS, HEATERS, LED LIGHTS (115 VOLT)

CASE LENGTH	EVAPORATOR FANS					CANOPY LIGHTS LED		OPTIONAL LED SHELF LIGHTS		MAX. LED LOAD (W/ ALL OPTIONS)		ANTI-SWEAT HEATERS		CONVENIENCE OUTLETS (OPTIONAL)		
	# OF EVAP FANS	BLADE DIA. (IN.)	BLADE PITCH (°)	AMPS	WATTS	AMPS	WATTS	AMPS	WATTS	AMPS	WATTS	AMPS	WATTS	# OUTLETS	VOLTS	AMPS
4.5F	4	8	10	1.2	32	0.2	22	0.3	35	0.5	58	0.4	50	1	115	15
5.5E	6	8	10	1.8	48	0.2	28	0.4	46	0.6	73	0.4	50	1	115	15

CONDENSING UNIT AND EVAPORATIVE PANS

CASE LENGTH	CONDENSING UNIT					EVAPORATIVE PAN			NEMA PLUG	EST. REFG. CHR.G. (LBS)
	NOM. HP	REFRIG.	Hz/Ph	Volts	RLA	VOLTS	AMPS	WATTS		
4.5E	1	R-404A	60 / 1	208	10.0	240	6.3	1500	L14-30P	3.6
5.5E	1 1/2		60 / 1	208	12.6	208	7.2	1500	L14-30P	4.4
4.5E	1 1/4	R-448A	60 / 1	208	10.0	240	6.3	1500	L14-30P	3.6
5.5E	1 3/4		60 / 1	208	12.6	208	7.2	1500	L14-30P	4.4

OPTIONAL HIGH OUTPUT LED LIGHTS (115 VOLT)

CASE LENGTH	CANOPY LIGHTS H.O. LED		OPTIONAL SHELF		MAX. H.O. LED LOAD	
	AMPS	WATTS	AMPS	WATTS	AMPS	WATTS
4.5E	N/A	N/A	N/A	N/A	N/A	N/A
5.5E	N/A	N/A	N/A	N/A	N/A	N/A

Controller Programmed Parameters

TY					PGM0010A01		PGM0010A02	
					STANDARD CASE REV A 8/7/17		Sheetz REV A 8/7/17	
Parameter	Code	Min	Max	Default	Actual (C)	Actual (F)	Actual (C)	Actual (F)
Temperature (set point)								
Deli (Type I)	---	-50.0°C	50.0°C	2.0°C	-3.3	26	-5.0	23
Deli (Deli Type II)	---	-50.0°C	50.0°C	2.0°C	-5.0	23		
Thermostat								
Differential	r01	0.1 K	20.0K	2.0 K	5.6	10	-12.2	10
Max. limitation of setpoint setting	r02	-49.0°C	50°C	50.0°C	5.6	42	5.6	42
Min. limitation of setpoint setting	r03	-50.0°C	49.0°C	-50.0°C	-7.8	18	-7.8	18
Adjustment of temperature indication	r04	-20.0 K	20.0 K	0.0 K	0.0 K		0.0 K	
Temperature unit (°C=0/°F=1)	r05	0	1	0	1		1	
Correction of the signal from S4	r09	-10.0 K	+10.0 K	0.0 K	0.0 K		0.0 K	
Correction of the signal from S3	r10	-10.0 K	+10.0 K	0.0 K	0.0 K		0.0 K	
Manual service, stop regulation, start regulation (-1, 0, 1)	r12	-1	1	0	1		1	
Displacement of reference during night operation	r13	-10.0 K	10.0 K	0.0 K	0.0 K		0.0 K	
Definition and weighting, if applicable, of thermostat sensors - S4% (100%=S4, 0%=S3)	r15	0%	100%	100%	100%		100%	
The heating function is started a number of degrees below the thermostats cutout temperature	r36	-15.0 K	-3.0 K	-15.0 K	-15.0 K		-15.0 K	
Activation of reference displacement r40	r39	OFF	ON	OFF	OFF		OFF	
Value of reference displacement (activate via r39 or DI)	r40	-50.0 K	50.0 K	0.0 K	0.0 K		0.0 K	
Alarm								
Delay for temperature alarm	A03	0 min	240 min	30 min	30 min		30 min	
Delay for door alarm	A04	0 min	240 min	60 min	60 min		60 min	
Delay for temperature alarm after defrost	A12	0 min	240 min	90 min	60		60	
High alarm limit	A13	-50.0°C	50.0°C	8.0°C	5.0	41	5.0	41
Low alarm limit	A14	-50.0°C	50.0°C	-30.0°C	-9.4	15	-9.4	15
Alarm delay DI1	A27	0 min	240 min	30 min	30 min		30 min	
Alarm delay DI2	A28	0 min	240 min	30 min	30 min		30 min	
Signal for alarm thermostat. S4% (100%=S4, 0%=S3)	A36	0%	100%	100%	100%		100%	
Compressor								
Min. ON-time	c01	0 min	30 min	0 min	1		1	
Min. OFF-time	c02	0 min	30 min	0 min	2		2	
Time delay for cutin of comp.2	c05	0 sec	999 sec	0 sec	0 sec		0 sec	
Compressor relay 1 must cutin and out inversely (NC-function)	c30	0 OFF	1 ON	0 OFF	0 OFF		0 OFF	
Defrost								
Defrost method (none;/;/<AS/=RIN;)	d01	no	br	;/;	;/;		;/;	
Defrost stop temperature	d02	0.0°C	25.0°C	6.0°C	11.1	52	11.1	52
Interval between defrost starts	d03	0 hours	240 hours	8 hours	4		4	
Max. defrost duration	d04	0 min	180 min	45 min	50		50	
Displacement of time on cutin of defrost at start-up	d05	0 min	240 min	0 min	0 min		0 min	
Drip off time	d06	0 min	60 min	0 min	0 min		0 min	
Delay for fan start after defrost	d07	0 min	60 min	0 min	0 min		0 min	
Fan start temperature	d08	-15.0°C	0.0°C	-5.0°C	-5.0°C		-5.0°C	
Fan cutin during defrost	d09	0	2	1	1		1	
0: Stopped 1: Running 2: Running during pump down and defrost								
Defrost Sensor (0=time, 1=S5. 2=S4)	d10	0	2	0	1		1	
@ump down delay	d16	0 min	60 min	0 min	0 min		0 min	
Drain delay	d17	0 min	60 min	0 min	0 min		0 min	
Max. aggregate refrigeration time between two defrosts	d18	0 hours	48 hours	0 hours	25		25	
Defrost on demand - S5 temperature's permitted variation during frost build-up. On central plant choose 20 K (=off)	d19	0.0 K	20.0 k	20.0 K		15		15
Delay of hot gas defrost	d23	0 min	60 min	0 min	0 min		0 min	
Fan								
Fan stop at cutout compressor	F01	no	yes	no	no		no	
Delay of fan stop	F02	0 min	30 min	0 min	0 min		0 min	
Fan stop temperature (S5)	F04	-50.0°C	50.0°C	50.0°C	50.0°C		50.0°C	

HACCP							
Actual temperature measurement for the HACCP	h01						
Last registered peak temperature	h10						
Selection of function and sensor for the HACCP function. HACCP function. 1 = S4 used (maybe also S3). 2 = S5	h11	0	2	0	0		0
Alarm limit for the HACCP function	h12	-50.0°C	50.0°C	8.0°C	8.0°C		8.0°C
Time delay for the HACCP alarm	h13	0 min.	240 min.	30 min.	30 min.		30 min.
Select signal for the HACCP function. S4% (100% = S4,	h14	0%	100%	100%	100%		100%
Real time clock							
Six start times for defrost. Setting of hours. 0=OFF	t01-	0 hours	23 hours	0 hours	0 hours		0 hours
Six start times for defrost. Setting of minutes. 0=OFF	t11-	0 min	59 min	0 min	0 min		0 min
Clock - Setting of hours	t07	0 hours	23 hours	0 hours	0 hours		0 hours
Clock - Setting of minute	t08	0 min	59 min	0 min	0 min		0 min
Clock - Setting of date	t45	1	31	1	1		1
Clock - Setting of month	t46	1	12	1	1		1
Clock - Setting of year	t47	0	99	0	0		0
Miscellaneous							
Delay of output signals after start-up	o01	0 s	600 s	5 s	5 s		5 s
input signal on Di1. Function4	o02	1	11	0	0		0
Network address	o03	0	240	0	0		0
On/Off switch (Service Pin message)	o04	OFF	ON	OFF	OFF		OFF
Access code 1 (all settings)	o05	0	100	0	0		0
9sed sensor type (Pt /PTC/NTC)	o06	Pt	ntc	Pt	Pt		Pt
Display step = 0.5 (normal 0.1 at Pt sensor)	o15	no	yes	no	no		no
Max hold time after coordinated defrost	o16	0 min	60 min	20	20		20
Select signal for display view. S4% (100%=S4, 0%=S3)	o17	0%	100%	100%	100%		100%
input signal on Di2. Function4	o37	0	12	0	0		0
Configuration of light function (relay 4)	o38	1	3	1	1		1
Activation of light relay (only if o38=2)	o39	OFF	ON	OFF	OFF		OFF
Rail heat On time during day operations	o41	0%	100%	100	100		100
Rail heat On time during night operations	o42	0%	100%	100	100		100
Rail heat period time (On time < Off time)	o43	6 min	60 min	10 min	10 min		10 min
Case cleaning. 0=no case cleaning. 1=Fans only. 2=All	o46	0	2	0	0		0
Selection of EL diagram. See overview page 6	o61	1	10	1	1		1
Download a set of predetermined settings. See overview	o62	0	6	0	0		0
Access code 2 (partly access)	o64	0	100	0	0		0
Save the controllers present settings to the	o65	0	25	0	0		0
Load a set of settings from the programming key	o66	0	25	0	0		0
Replace the controllers factory settings with the present	o67	OFF	On	OFF	OFF		OFF
Service							
Status codes are shown on page 17	S0-S33						
Temperature measured with S5 sensor	u09						
Status on Di1 input. on/1=closed	u10						
Temperature measured with S3 sensor	u12						
Status on night operation (on or off) 1=closed	u13						
Temperature measured with S4 sensor	u16						
Thermostat temperature	u17						
Read the present regulation reference	u28						
Status on Di2 output. on/1=closed	u37						
Temperature shown on display	u56						
Measured temperature for alarm thermostat	u57						
Status on relay for cooling	u58						
Status on relay for fan	u59						
Status on relay for defrost	u60						
Status on relay for railheat	u61						
Status on relay for alarm	u62						
Status on relay for light	u63						
Status on relay for valve in suction line	u64						
Status on relay for compressor 2	u67						

TY Cold Maintenance

Case Cleaning

To insure long life, proper sanitation and minimum maintenance costs, the refrigerator should be thoroughly cleaned frequently. **SHUT OFF FAN BEFORE CLEANING:** It can be unplugged within the case, or shut off entire case at the source. The interior bottom may be wiped with any domestic soap or detergent based cleaners. Sanitizing solutions will not harm the interior bottom,

WARNING! DO NOT USE WATER HOSES! A self contained case empties into an evaporator pan that **WILL OVERFLOW IF TOO MUCH WATER IS INTRODUCED** during cleaning

- USE WATER AND A MILD DETERGENT FOR THE EXTERIOR ONLY
- Wipe interior with damp non abrasive cloth. Soap and hot water are not enough to kill bacteria; a sanitizing solution must be included with each cleaning process to eliminate bacteria.
- Clean any visible debris surrounding or on top of the drain location. The drain is located under the deck pans.
- DO NOT USE A CHLORINATED CLEANER ON ANY SURFACE.
- DO NOT USE ABRASIVES OR STEEL WOOL SCOURING PADS (these will mar the finish)

- DO NOT USE A CLEANING OR SANITIZING SOLUTION THAT HAS AN OIL BASE (these will dissolve the butyl sealants) or an AMMONIA BASE (this will corrode the copper components of the case)

Service

- Replace Filter every 6 months or as needed to maintain efficient operation. (If applicable)
- To maintain good refrigeration performance, a refrigeration service person should be called periodically (at least twice a year) to clean the discharge honeycomb and remove any accumulated dirt from the condenser coil and condensate evaporator pan on self-contained models. **POOR CIRCULATION OF AIR THROUGH THE CONDENSER COIL WILL RESULT IN POOR REFRIGERATION PERFORMANCE.**
- Dirt accumulation inside the condensate evaporator pan will reduce the pan's capacity and affect the efficiency of the heater causing a burned out heater and an overflow of defrost water onto the store floor.

Tips and Troubleshooting

Before calling for service:

- Check power. Ensure reliable electrical power supply to the equipment
- Check shelf loading. Overstocking will adversely affect case performance.
- If frost is collecting on fixture or product, verify that store Humidity Control is working properly, and that no outside doors/windows allow moisture into store.

TY Cold Maintenance

Stainless Steel Cleaning and Care

There are three basic things, which can break down your stainless steel's passivity layer and allow corrosion.

1. Mechanical Abrasion

Mechanical Abrasion means those things that will scratch the steels surface. Steel Pads, wire Brushes, and Scrapers are prime examples.

2. Water

Water comes out of our tap in varying degrees of hardness. Depending on what part of the country you live in, you may have hard or soft water. Hard water may leave spots. Also, when heated, hard water leaves deposits behind that if left to sit, will break down the passive layer and rust your stainless steel. Other deposits from food preparation and service must be properly removed.

3. Chlorides

Chlorides are found nearly everywhere. They are in water, food and table salt. One of the worst perpetrators of chlorides can come from household and industrial cleaners.

Don't Despair! Here are a few steps that can help prevent stainless steel rust.

1. Use the Proper Tools

When cleaning your stainless steel products, take care to use non-abrasive tools. Soft Clothes and plastic scouring pads will NOT harm the steel's passive layer. Stainless steel pads can also be used but the scrubbing motion must be in the same direction of the manufacturer's polishing marks.

2. Clean With the Polish Lines

Some stainless steels come with visible polishing lines or "grain". When visible lines are present, you should ALWAYS scrub in a motion that is parallel to them. When the grain cannot be seen, play it safe and use a soft cloth or plastic scouring pad.

3. Use Alkaline or

Non-chloride Containing Cleaners

While many traditional cleaners are loaded with chlorides, the industry is providing an ever increasing choice of non-chloride cleaners. If you are not sure of your cleaner's chloride content contact your cleaner supplier. If they tell you that your present cleaner contains chlorides, ask for an alternative. Also, avoid cleaners containing quaternary salts as they also can attack stainless steel & cause pitting and rusting.

4. Treat your Water

Though this is not always practical, softening hard water can do much to reduce deposits. There are certain filters that can be installed to remove distasteful and corrosive elements. If you are not sure of the proper water treatment, call a treatment specialist.

5. Keep your Food Equipment Clean

Use alkaline or non-chlorinated cleaners at recommended strength. Clean frequently to avoid build-up of hard, stubborn stains.

If you boil water in your stainless steel equipment, remember the single most likely cause of damage is chlorides in the water. Heating cleaners that contain chlorides has a similar effect.

6. RINSE, RINSE, RINSE

If chlorinated cleaners are used you must rinse, rinse, rinse and wipe dry immediately. The sooner you wipe off standing water, especially when sit contains cleaning agents, the better. After wiping the equipment down, allow it to air dry for the oxygen helps maintain the stainless steel's passivity film.

7. Never Use Hydrochloric Acid (Muriatic Acid) on Stainless Steel

8. Regularly Restore/Passivate Stainless Steel

Service Tips

WARNING

ALWAYS DISCONNECT THE ELECTRICAL POWER AT THE MAIN DISCONNECT WHEN SERVICING OR REPLACING ANY ELECTRICAL COMPONENT OF THIS REFRIGERATOR. THIS INCLUDES, BUT IS NOT LIMITED TO SUCH ITEMS AS FANS AND THERMOSTATS.

Fan Blade Replacement

The evaporator fan is located directly under the deck pan. Should the fan blade ever need servicing. ALWAYS REPLACE THE FAN BLADE WITH THE RAISED EMBOSSED SIDE OF THE BLADE INSTALLED TOWARD THE MOTOR.

Honeycomb Removal & Cleaning

CAUTION: DO NOT TEAR THE HONEYCOMB

1) Remove the honeycomb assembly as follows:

Insert a small Phillips screwdriver behind the rear edge of the honeycomb on the right hand end and gently pull down. The bottom of the honeycomb will drop down. Continue down the length of the case, lifting the honeycomb out.

2) To clean honeycomb:

Mix powdered detergent, in warm water. (5 to 7 Tablespoons per gallon)

Immerse or spot clean the honeycomb. Use care not to damage the cell structure of the honeycomb.

Rinse thoroughly in clean water. Shake excess water from the honeycomb and dry. (If heat is used, do not exceed 140° F dry heat)

3) **Install honeycomb** by inserting the notched side up against the deflector and press upwards inserting the bottom of the honeycomb into the back ledge. Slide along the honeycomb, pressing the front edge upward into the ledge. Be careful no to damage the cells or cut yourself on the edges of the honeycomb.

Ballast/LED Driver Replacement

The power supply for the LED fixtures is located under the case in a dedicated electrical box.

For access to the ballast:

- Remove Close-off panels (See Close-off Removal for reference)
- Remove screws to grille to expose electrical conduit?
- Replace or service the ballast as required and replace the canopy in reverse order of removal.

Stocking

Improper temperature and lighting will cause serious product loss. Discoloration, dehydration and spoilage can be controlled with proper use of the equipment and handling of product. Product temperature should always be maintained at a constant and proper temperature. This means that from the time the product is received, through storage, preparation and display, the temperature of the product must be controlled to maximize life of the product. Hussmann cases were not designed to “heat up” or “cool down” product - but rather to maintain an item’s proper temperature for maximum shelf life. To achieve the protection required always:





1. Minimize processing time to avoid damaging temperature rise to the product. Product should be at proper temperature.
2. Keep the air in and around the case area free of foreign gasses and fumes or food will rapidly deteriorate.
3. Maintain the display merchandisers temperature controls as outlined in the refrigerator section of this manual.
4. Do not place any product into these refrigerators until all controls have been adjusted and they are operating at the proper temperature. Allow merchandiser to operate a minimum of three (3) hours before stocking with any product.
5. When stocking, never allow the product to extend beyond the recommended load limit. Air discharge and return air flue must be unobstructed at all times to provide proper refrigeration.
6. Avoid the use of supplemental flood or spot lighting. Display light intensity has been designed for maximum visibility and product life at the factory.

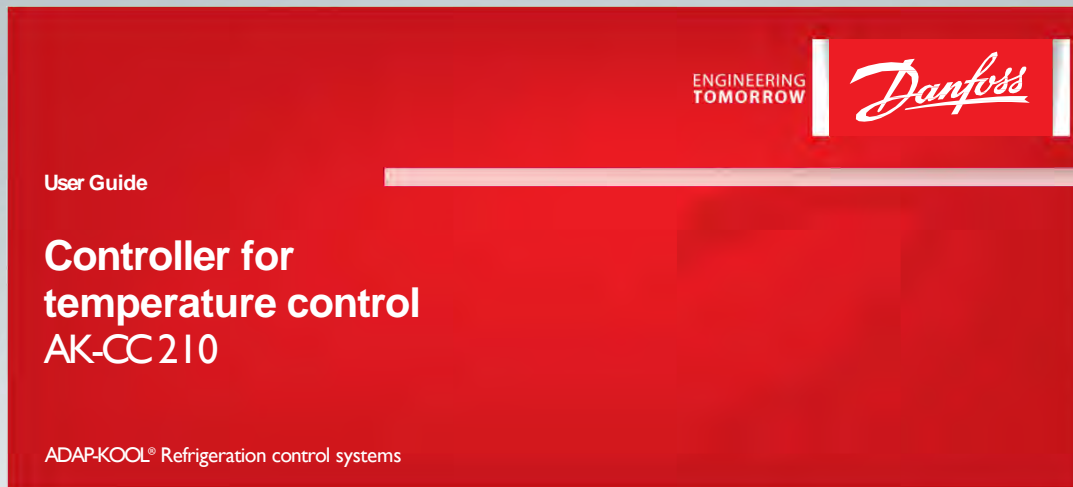

This warning does not mean that Hussmann products will cause cancer or reproductive harm, or is in violation of any product-safety standards or requirements. As clarified by the California State government, Proposition 65 can be considered more of a ‘right to know’ law than a pure product safety law. When used as designed, Hussmann believes that our products are not harmful. We provide the Proposition 65 warning to stay in compliance with California State law. It is your responsibility to provide accurate Proposition 65 warning labels to your customers when necessary. For more information on Proposition 65, please visit the California State government website.

Danfoss Controller







- ①  Open Camera
- ②  iPhone User
Hold the camera up to the QR code
-  Android User
Open QR Code Reader app if necessary.
Hold the camera up to the QR code
- ③  Tap the notification to be taken to the destination of the QR code

Dixell Controller

026-1210 Rev 3 03-FEB-2015

XR75CX Digital Controller for Medium-Low Temperature Refrigeration Applications Installation and Operation Manual



- ①  Open Camera
- ②  iPhone User
Hold the camera up to the QR code
- ③  Android User
Open QR Code Reader app if necessary.
Hold the camera up to the QR code
- ④  Tap the notification to be taken to the destination of the QR code

Start up

Startup Instructions

1. Turn Power to ON
2. Preheat merchandiser for 10 minutes before loading.
3. Load fully cooked / heated foods only (internal product temperatures > 160°F). Case is not designed to heat food.
4. Use only approved hot food containers in direct contact with shelves; Do NOT stack containers.
5. Check Internal Product Temperature periodically, using a pocket food thermometer.
6. Adjust *SHELF-Setpoint as needed to maintain ideal Internal Product Temperatures:
 - (1) Press SET key, (2) Press UP ARROW / DOWN ARROW keys to change *SHELFSetpoint, (3) Press SET key again.
 - When increasing *SHELF-temperatures, heat food in a separate cooking/warming oven, then reload.

NOTES:

- ***Controller temperature indicates SHELF-temperature only (not Internal Product Temperature).**
- **Shelves are pre-set to 185°F, suitable for many foods in approved containers. Do not overheat as containers may melt.**
- **Refer to Instruction Manual for detailed operating instructions.**
- **Refer to NSF- and local- regulations for internal product temperature requirements.**
- **SERVICE: For heated component failures, contact HATCO Parts and Service at 800-558-0607.**

Operation

- Food must be preheated BEFORE loading; this case MUST NOT be used to cook or heat product.
- Check Internal Product Temperatures (IPTs) periodically with a portable food thermometer
- Do not stack containers.
- Be careful not to overheat as containers may melt.
- When restocking, rotate food products: oldest foods should be placed in front and served first.
- Wipe spills immediately to maintain product freshness, minimize odors, reduce end-of-day cleanup (See Maintenance Section).

Adjustment

- Use a pocket food thermometer regularly to check internal product temperatures.
- Before adjusting shelf temperatures, ensure only pre-heated foods are being loaded into the case.
- Shelves are pre-set to 185°F, suitable for many food and container types.
- Adjust SHELF-Setpoint as needed to maintain ideal Internal Product Temperatures:
 - (1) Press SET key,
 - (2) Press UP ARROW / DOWN ARROW keys to change *SHELF-Setpoint,
 - (3) Press SET key again.
 - (4) When increasing SHELF-temperatures, heat food in a separate cooking/warming oven, then reload.
- Temperature controls should be adjusted to the lowest possible setting that will maintain proper internal product temperature.
- See troubleshooting guide if, after adjustment, pre-heated product does not maintain regulatory temperature.

Holding Temperature Guide

- Food must be preheated BEFORE loading the case; the case must not be used to heat product.
- Always consult local health and sanitation regulations for internal product temperature and holding requirements.
- Holding Temperatures listed below are internal product temperatures, and are guidelines only.

HOLDING TEMPERATURE GUIDELINES* Internal Product Temperatures (IPT)	
MEAT	*IPT
CHICKEN / POULTRY	160° - 175°F

Start up

Cal Rod Controls

Each hot unit has an individual heater with a separate control. These are thermostatically controlled with an indicator light showing when the heater has cycled on and is heating. The light below each control knob indicates when the well heater is heating.

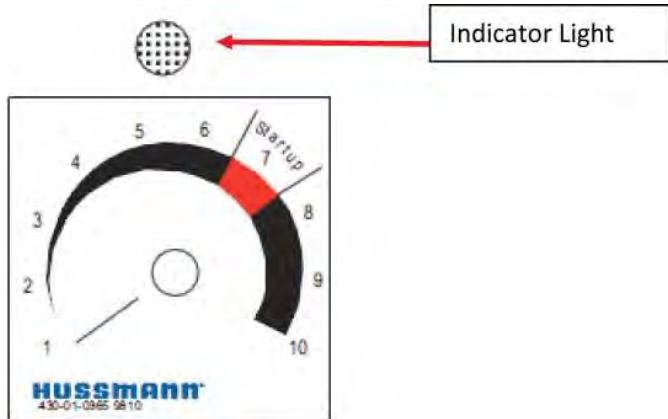

Overhead Heating System

Overhead heaters and Incandenscent lights are located above each shelf to provide both top heat and illumination.

To obtain the proper food temperatures, the shelf heater and overhead heater must be adjusted. Maximum limits should be avoided to prevent overcooking or drying out of food.

Food temperatures can be accurately determined only through the use of food thermometers!

Important Food Handling Tips:

1. Preheat case 30 minutes before loading product.
2. Never place food directly into the warmer. Always use an inset.
3. Food must be displayed in a single layer, in contact with the heat source at all times.
4. Using thermometer, check product before loading in case (160°F-180°F).
5. At start, set control to "6". After loading, recheck temperature every ½ hour to see that unit is operating properly. Adjust the temperature to maintain a product temperature of 140°F (60°C) and above. The setting will depend on the type and quantity of product being displayed. Be sure to test product temperature with a thermometer frequently for good product maintenance.
6. Food should be rotated periodically.
7. At the end of the day, remove product and let case cool. Then clean with soap and water.

Standard Hot Case Settings

When Heater (Cal Rods) are installed

Straight Section Components		Minimum Controller Setting
Heater Rod	Rated 240 Vac, 3.4 Watts/cm ² Minimum. Provided above each warming Surface.	6
Buffet Warmer on Deck	208 Vac, 780 Watts Minimum.	200°F
Buffet Warmer on Shelf	208 Vac, 590 Watts Minimum.	200°F
Incandescent Bulbs	120/130 Vac. 60watts minimum. Mimimum 2 per warming surface.	N/A

½ Round Section Components		Minimum Controller Settings
Heater Rod on ½ Round Top	Rated 240 Vac, 3.4 Watts/cm ² Minimum. Provided above each ½ Round Buffet Warmer on Shelf.	High
Heater Rod on ½ Round Shelf	Rated 240 Vac, 3.4 Watts/cm ² Minimum. Provided above each ½ Round Buffet Warmer on Deck.	6
½ Round Buffet Warmer on Deck	208 Vac, 894 Watts Minimum.	210°F
½ Round Buffet Warmer on Shelf	208 Vac, 520 Watts Minimum.	210°F
Incandescent Bulbs	120/130 Vac, 60 watts minimum. Minimum 2 per warming surface.	N/A

When Heater (Cal Rods) are not installed (Fluorescent/Incandescent bulbs may not be provided):

Straight Section Components		Minimum Controller Setting
Buffet Warmer on Deck	208 Vac, 780 Watts Minimum.	210°F
Buffet Warmer on Shelf	208 Vac, 590 Watts Minimum.	210°F

½ Round Section Components		Minimum Controller Settings
½ Round Buffet Warmer on Deck	208 Vac, 894 Watts Minimum.	215°F
½ Round Buffet Warmer on Shelf	208 Vac, 520 Watts Minimum.	215°F

Operation

Instruction sheet

Use the instructions below to operate the controls for a unit with multiple heated shelves. The controls are located in a remote mounted control panel and consist of a Power ON/OFF switch and three, four, or five digital temperature controllers, depending on the number of heated shelves in the unit.

Operation

Use the following instructions to operate the controls on a multi-heated shelf control panel.

- Move the Power ON/OFF switch to the ON position.
 - The digital temperature controllers will energize and the current temperature of each shelf will appear on the corresponding display.
 - The phrase "out 1" will appear in the upper left corner of each display to show that the shelves are in heat mode.

CAUTION

BURN HAZARD: Some exterior surfaces on unit will get hot. Use caution when touching these areas.

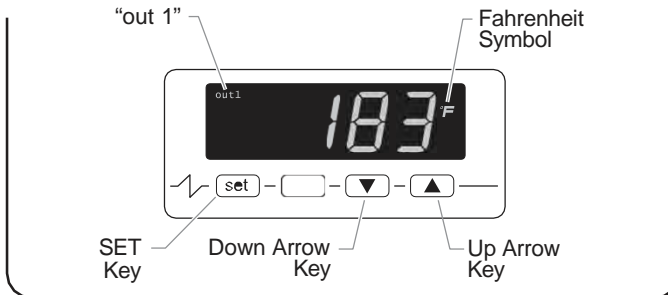

Figure 1. Digital Temperature Controller

- On each digital temperature controller, press and release the **set** key to verify the setpoint temperatures.

- The setpoint temperature will be shown for 15 seconds. After 15 seconds, the display will revert to the current temperature of the corresponding shelf. To change a setpoint temperature, refer to the "Changing the Setpoint Temperature" procedure.

NOTE: Once a setpoint temperature is changed, the new setpoint temperature will remain in memory until it is changed again.

- Allow the heated shelves 10 minutes to reach operating temperature before loading preheated food product.

Changing the Setpoint Temperature

Use the following procedure to change the setpoint temperature on a digital temperature controller.

- Press and release the **set** key. The current setpoint temperature will be shown on the display and "out 1" will flash in the upper left corner.
- Press the **▲** key or **▼** key within 15 seconds to change the setpoint temperature. If no key is pressed within 15 seconds, the display will revert to the current temperature of the unit.
- Press the **set** key or wait 15 seconds to lock in the new setpoint temperature.

Locking/Unlocking a Digital Temperature Controller

The keys on a digital temperature controller can be locked to prevent unauthorized changes to the settings.

To lock the keys of a digital temperature controller:

- Press and hold both the **set** key and **▼** key at the same time for over two seconds. The message "Loc" will appear on the display.

To unlock the keys of the digital temperature controller:

- Press and hold both the **set** key and **▼** key at the same time until the message "UnL" appears on the display.

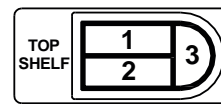

Heated Shelf Control Reference Guide

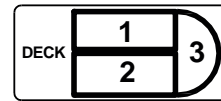

Cal Rod Control Reference Guide

DECK	TOP SHELF
1	1
2	2
3	3

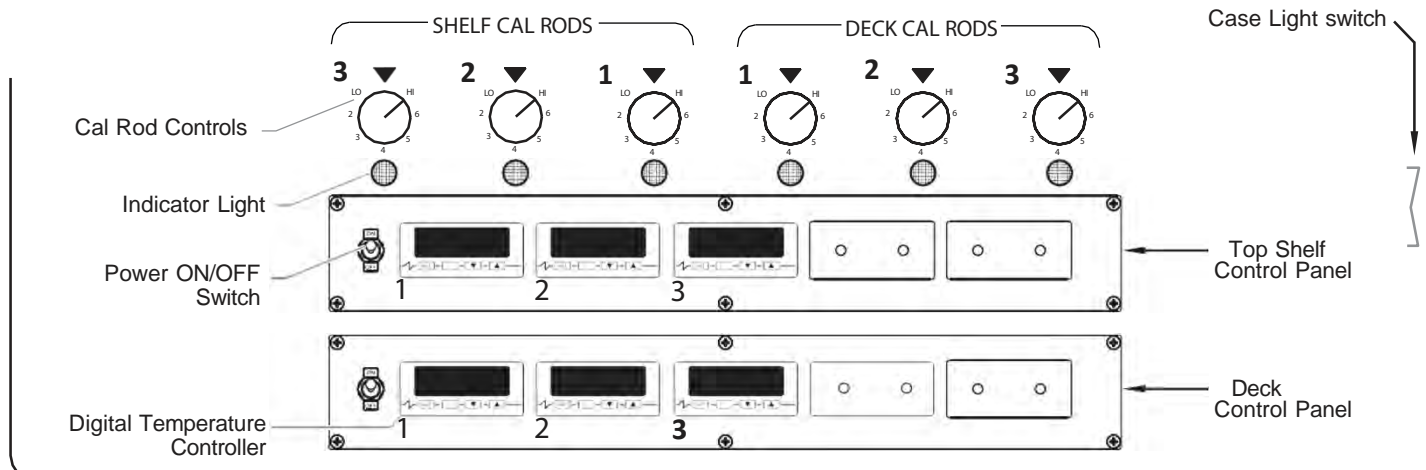

Controller temperature indicates *SHELF-temperature only (not product temperature)

Electrical

IMPORTANT! IT IS IMPERATIVE THAT CASES BE LEVELED FROM FRONT TO BACK AND SIDE TO SIDE PRIOR TO JOINING. A LEVEL CASE IS NECESSARY TO INSURE PROPER OPERATION.

ALL CASES WERE LEVELED AND JOINED PRIOR TO SHIPMENT, TO INSURE THE CLOSEST POSSIBLE FIT WHEN CASES ARE JOINED IN THE FIELD.



TO AVOID REMOVING CONCRETE FLOORING, BEGIN LINEUP LEVELING FROM THE HIGHEST POINT OF THE STORE FLOOR.

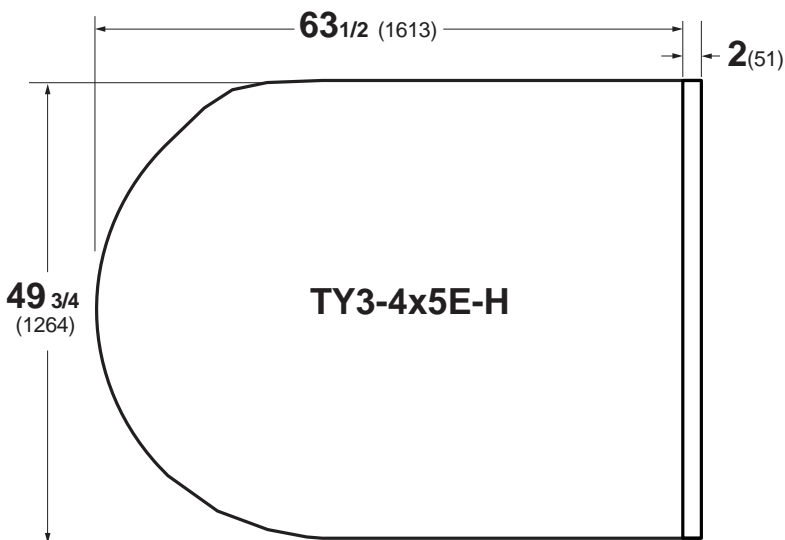

CASE MUST BE GROUNDED



DANGER

BEFORE SERVICING

ALWAYS DISCONNECT ELECTRICAL POWER AT THE MAIN DISCONNECT WHEN SERVICING OR REPLACING ANY ELECTRICAL COMPONENT.

This includes (but not limited to) Heaters and Lights.

Electrical Circuit Identification

Standard lighting for all models will be full length fluorescent lamps located within the case. The switch controlling the lights is located at the top right of the case.

TY3-4-H Self-Service Hot End

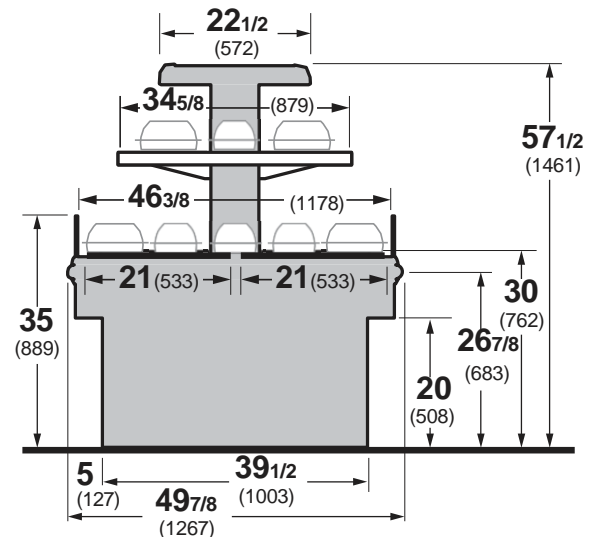

Wiring Diagram Index

4X4E-H W/BULBS NEW CTRLR	4'	W6600136
EC-4X4E-H EXTENDED CANOPY NEW CTRLR	4'	W6600697
4X5E-H W/CAL RODS NEW CTRLR	5'	W6600075
4X5E-H W/BULBS NEW CTRLR	5'	W6600103

CIRCUIT #1

208V @ 240V
L1 13.7 15.8
L2 13.7 15.8
L3 10.6 12.2

4563W @ 208VAC
6069W @ 240VAC

REV	ECN	DATE	REVISION DESCRIPTION	REV BY	CHK BY	APPR BY
A	95945	2014/02/02	RELEASED TO PRODUCTION	CB	CB	CB
B	EDN-CAP-000264	2016/09/06	REDUCED THE WIRE GAUGE	CB	CB	CB
C	EDN-CAP-0013876	2016/09/05	REVISED GROUND WIRE	CB	CB	CB
D	EDN-COD-0018279	2022/01/01	REVISED CULR WRING	CB	CB	CB

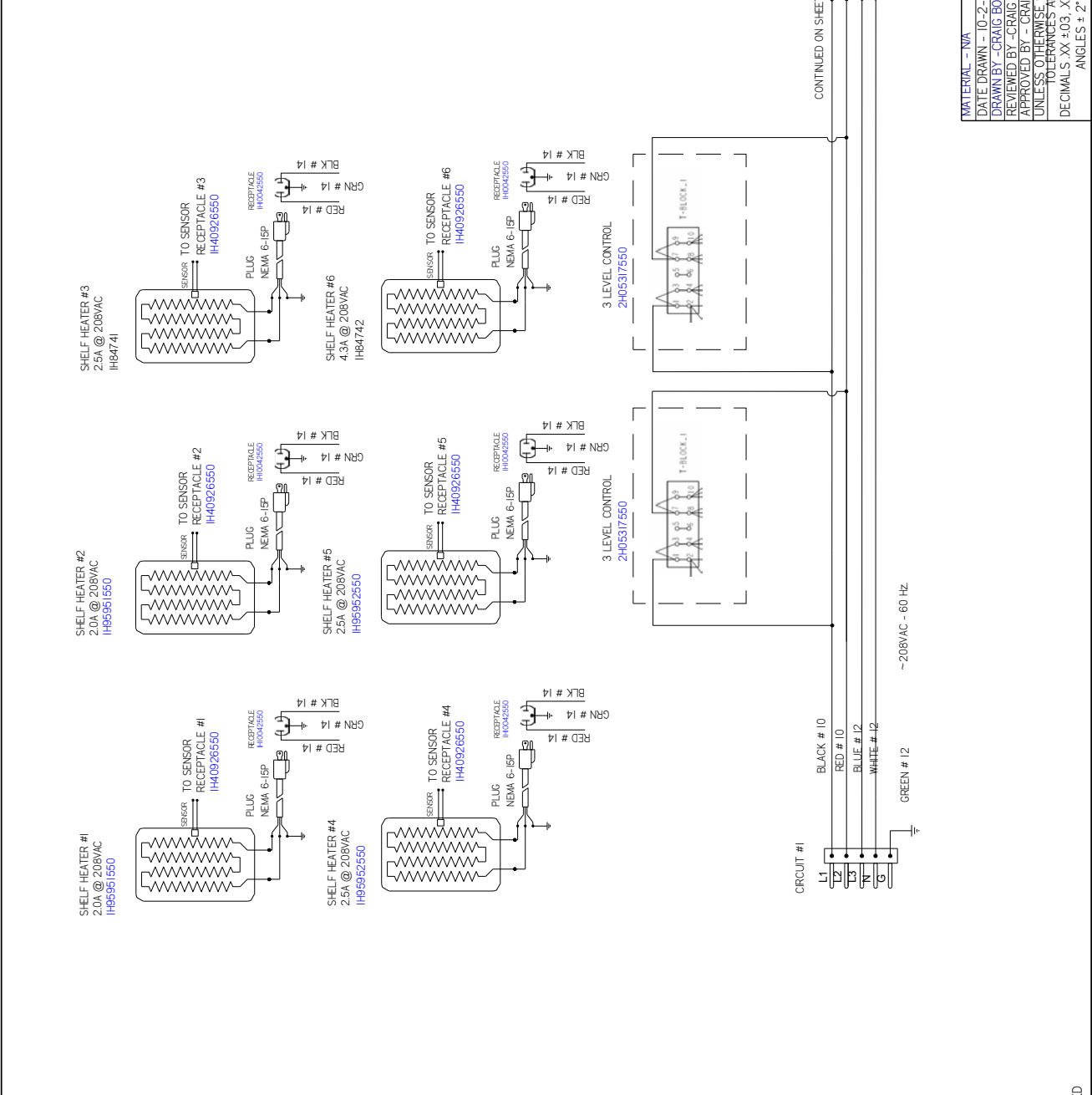

MATERIAL - N/A
 DATE DRAWN - 10-2-14
 DRAWN BY - CRAIG BOOREY
 REVIEWED BY - CRAIG BOOREY
 APPROVED BY - CRAIG BOOREY
 UNLESS OTHERWISE SPECIFIED DIMENSIONS ARE IN INCHES
 TOLERANCES ARE:
 DECIMALS .XX +0.3 .XXX +0.10
 ANGLES ± 2°
 PROJECTION

HUSMANN
 DIAGRAM= IY3-4X4E-H
 ECN# - 951945
 REF -
 SHEET 1 OF 3
 THIRD

W6600136 D

NOTES
CASE MUST BE GROUNDED

REV	EON	DATE	REVISION DESCRIPTION	REV BY	CHKD BY	APPR BY
A	951945	204/002	RELEASED TO PRODUCTION	CB	CB	CB
B	ECN-CAP-0002614	2016/02/6	REDUCED THE WIRE GAUGE	CB	CB	CB
C	ECN-CAP-0003876	2018/09/05	REVISED GROUND WIRE	CB	CB	CB
D	ECN-COD-0015279	2022/03/11	REVISED CLR WIRING	CB	CB	CB

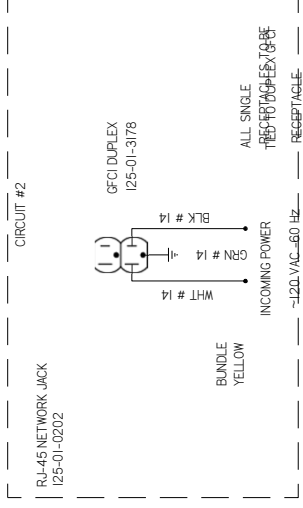

HEATER RECEPTACLE WIRING
CONTROL PANEL

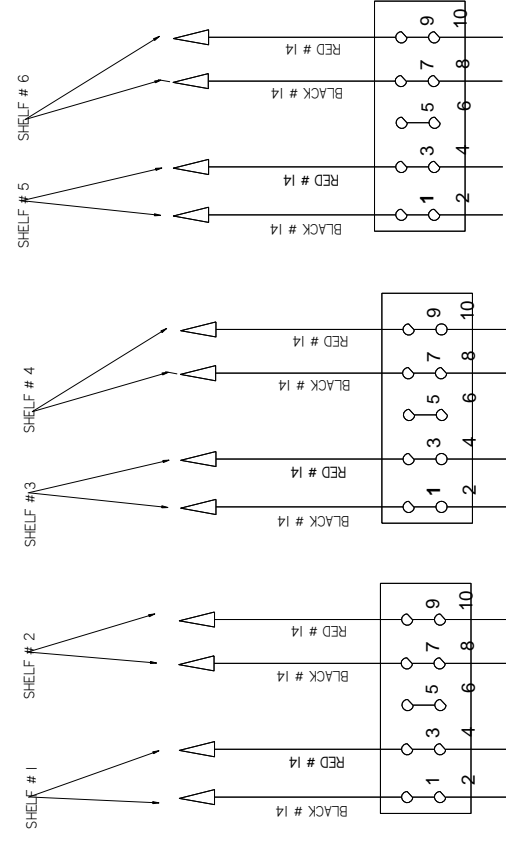

ACLE WIRING
SENSOR RECEPT
CONTROL PANEL

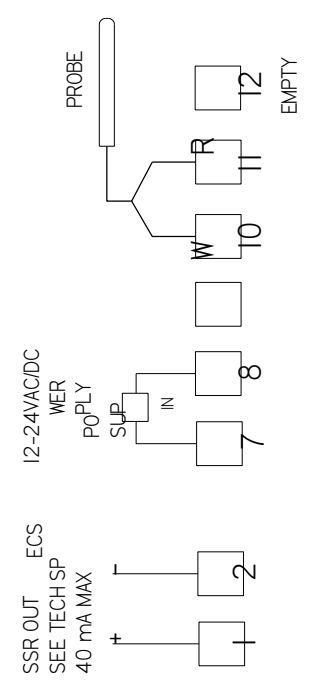

MATERIAL - IVA
DATE DRAWN - 10-2-14
DRAWN BY - CRAIG BOOREY
REVIEWED BY - CRAIG BOOREY
APPROVED BY - CRAIG BOOREY
UNLESS OTHERWISE SPECIFIED DIMENSIONS ARE IN INCHES.

ECN# - 951945
REF -
SHEET 2 OF 3
H

TOLERANCES ARE:
DECIMALS .XX +0.3 .XXX ±0.0
THIRD ANGLE PROJECTION
ANGLES 2°

HUSSMANN
DIAGRAM-1Y3-4X4E-

W6600136 D

CASE MUST BE GROUNDED
NOTES:

REVISION HISTORY			
REV	ECN	DATE	DESCRIPTION
A	95945	20/4/02	RELEASED TO PRODUCTION
B	ECN-CAP-000264	20/6/06	REDUCED THE WIRE GAUGE
C	ECN-CAP-0013876	20/6/06	REVISED GROUND WIRE
D	ECN-COD-0018279	20/2/01	REVISED CILR WIRING

INCANDESCENT LAMP
 BULB 100W 115V
 (14) 2H06888550

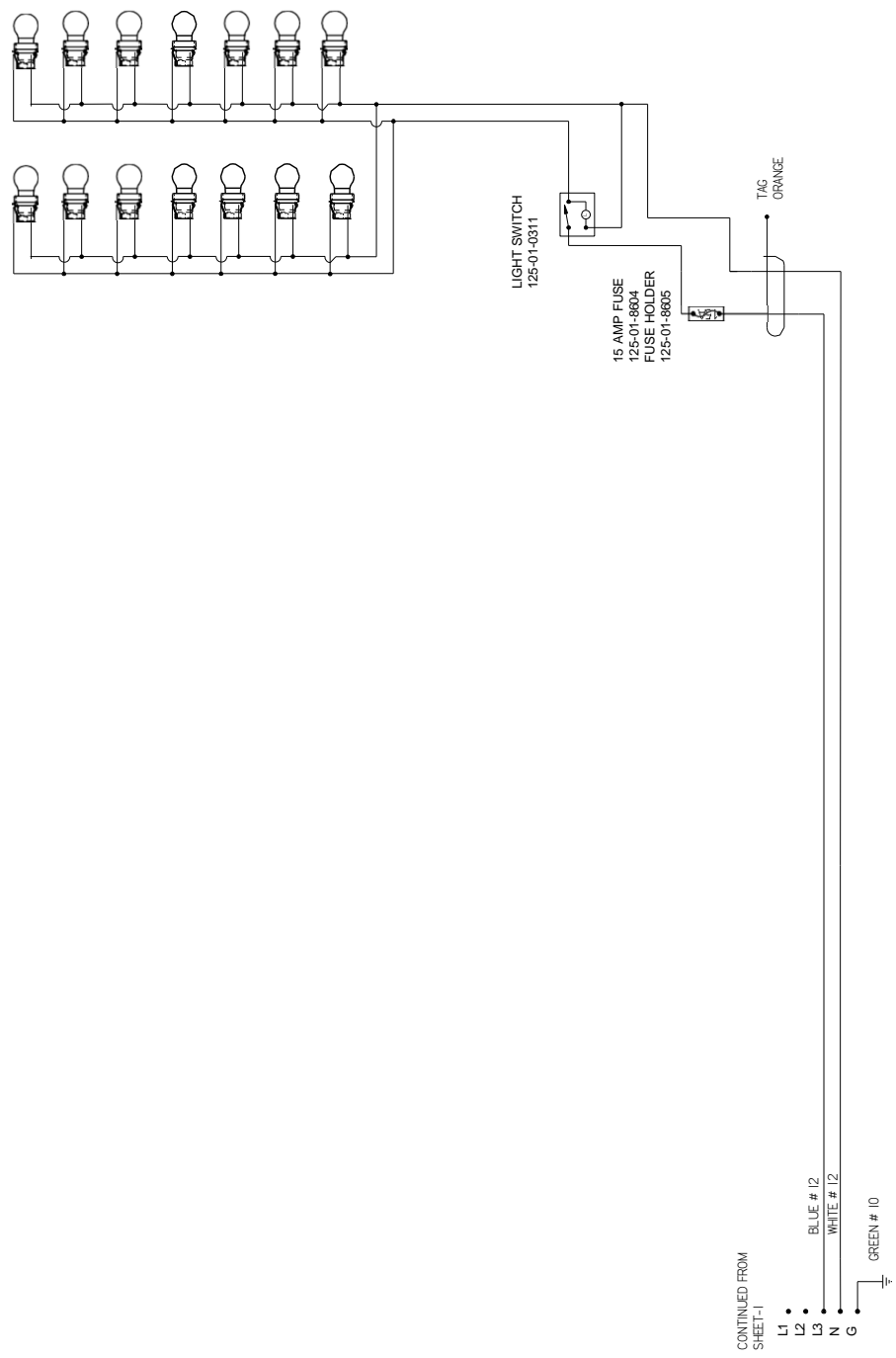

MATERIAL - N/A	
DATE DRAWN - 10-2-14	ECN# - 951945
DRAWN BY - CRAIG BOOREY	REF -
REVIEWED BY - CRAIG BOOREY	SHEET 3 OF 3
APPROVED BY - CRAIG BOOREY	THIRD
UNLESS OTHERWISE SPECIFIED DIMENSIONS ARE IN INCHES	
TOLERANCES ARE:	
DECIMALS .XX ±0.3 .XXX ±0.10	ANG. E
ANGLES ± 2°	PROJECTION
DIAGRAM-1Y3-4X4E-	
H	
W6600136	
D	

NOTES:
 CASE MUST BE GROUNDED

REV	ECN	DATE	REVISION DESCRIPTION	REV BY	CHKD BY	APPR BY
C	ECN-COD-0011329	6-19-20	CHGD TO 1 PHASE, ADDED PLUG	CB	CB	CB
D	ECN-COD-0016279	3-11-22	REVISED CTR WIRING	CB	CB	CB

CIRCUIT #1	WIRING
200V	
1-1	
1-2	
1-3	

7259W @ 208VAC

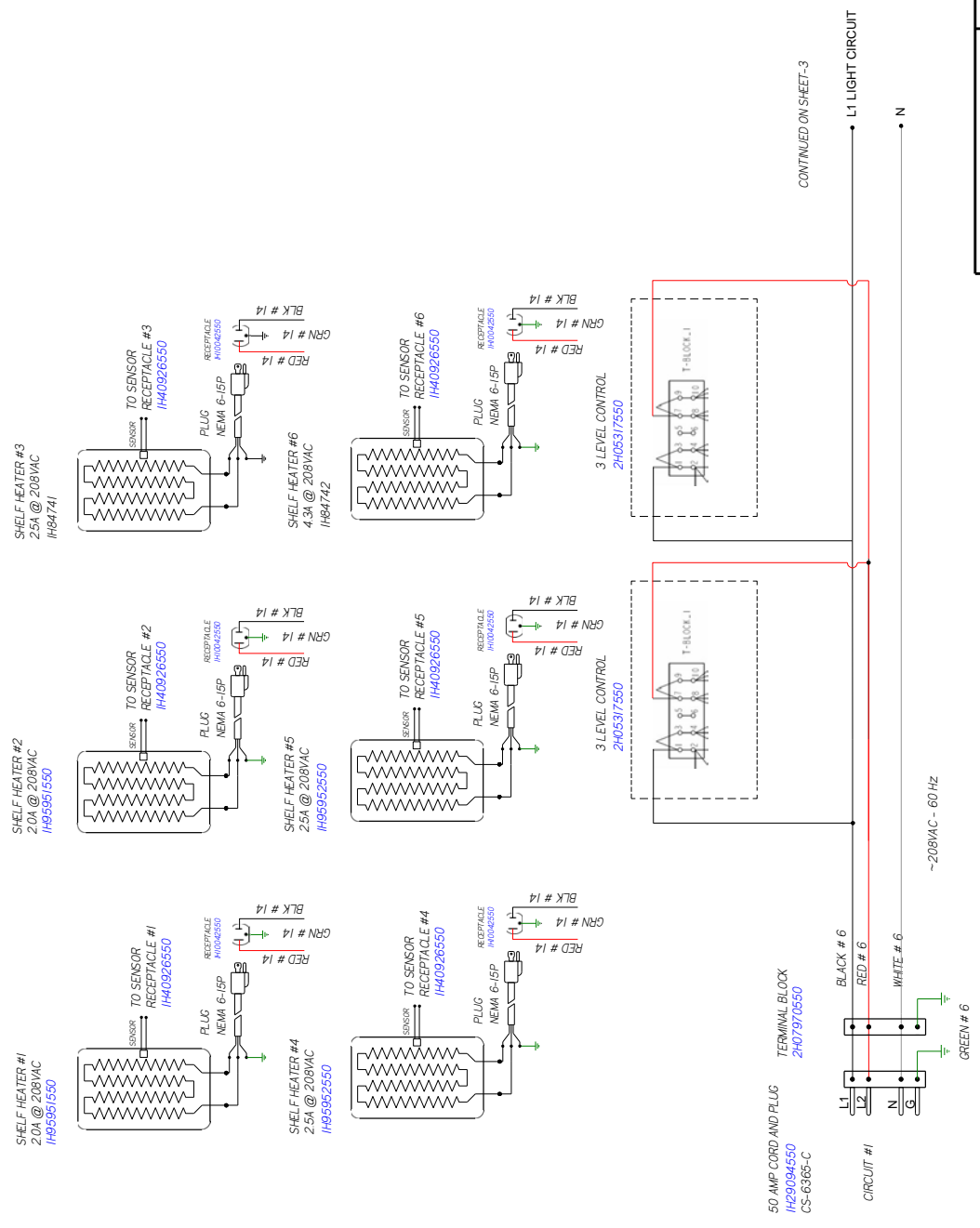

CONTINUED ON SHEET-3

HUSSMANN	
DIAGRAM-TY3EC-4X 4E-H	
FACTORY 14GA WIRE	---
FACTORY 10GA WIRE	---
FIELD WIRE	---
DO NOT SCALE DRAWING	---
SHEET 1 OF 3	W6600697

UL COLOR CODES / ABBREVIATIONS	WHITE = WT
RED = RD	GREEN = GN
BLACK = BK	BROWN = BN
BLUE = BL	ORANGE =
YELLOW =	OR VIOLET =
YL GRAY =	VT
GY	

- NOTES:
1. PRINTED DOCUMENT REQUIRED SETTING. ALL COLORS BLACK & WHITE
 2. CASE & ANY REMOVABLE PANEL WITH ELECTRICAL PARTS MUST BE GROUNDED.
 3. WHEN PASSING WIRES THROUGH METAL HOLES A GROMMET MUST BE USED

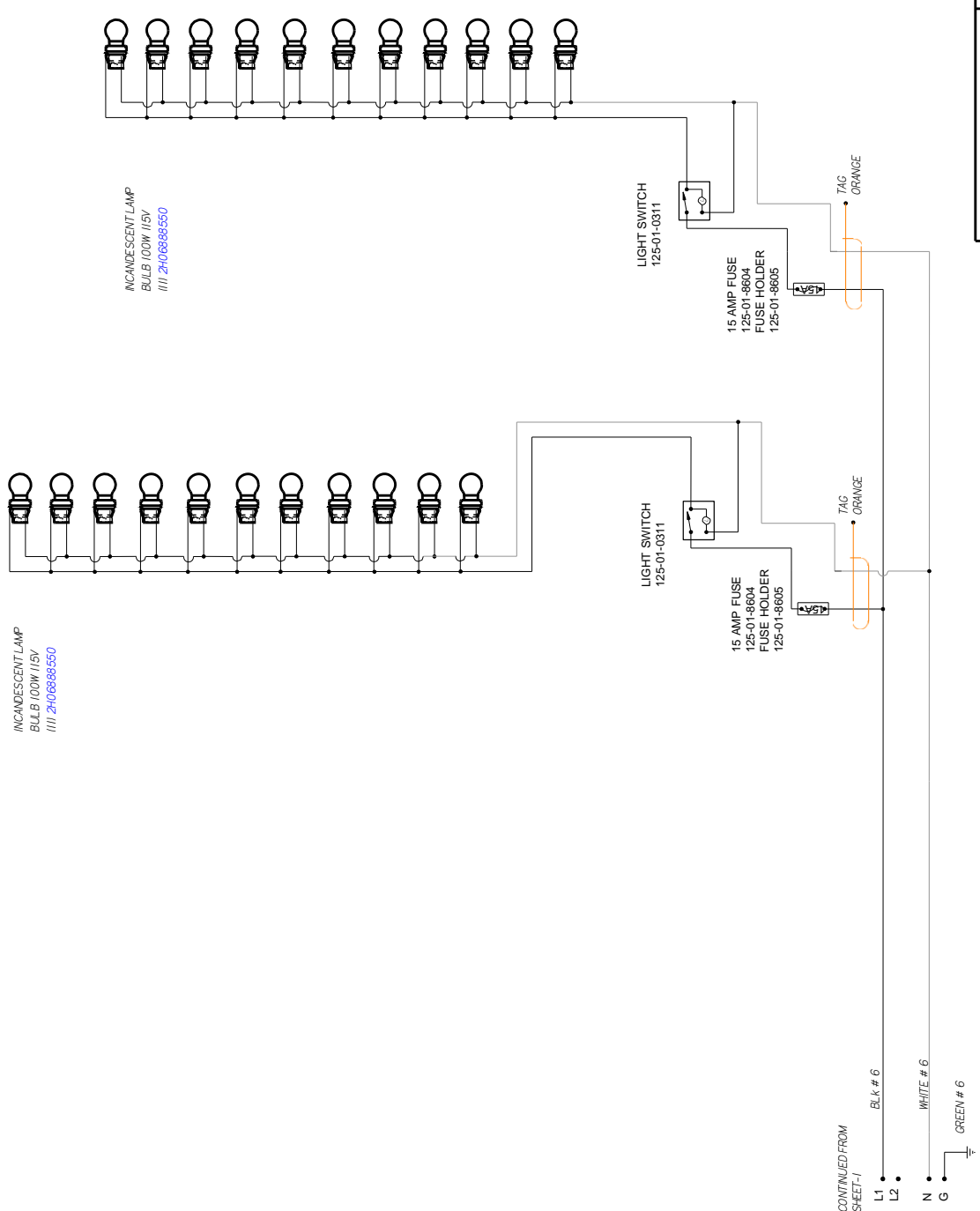

INCANDESCENT LAMP
BULB 100W 115V
IIII 2406888550

INCANDESCENT LAMP
BULB 100W 115V
IIII 2406888550

LIGHT SWITCH
125-01-0311

15 AMP FUSE
125-01-8604
FUSE HOLDER
125-01-8605

CONTINUED FROM
SHEET-1

L1
L2
N
G

BLK # 6
WHITE # 6
GREEN # 6

TAG ORANGE

TAG ORANGE

HUSSMANN	
DIAGRAM-TY3EC-4X 4E-H	
FACTORY 14GA WIRE	FIELD WIRE
FACTORY LOGA WIRE	---
---	---
DO NOT SCALE DRAWING	
SHEET 3 OF 3	
W6600697	

UL COLOR CODES / ABBREVIATIONS	
RED = RD	WHITE = WT
BLACK = BK	GREEN = GN
BLUE = BL	BROWN = BN
YELLOW = YL	ORANGE = OR
GRAY = GR	OR VIOLET = VT
GY	

- NOTES:
1. PRINTED DOCUMENT REQUIRED SETTING: ALL COLORS BLACK & WHITE
 2. CASE & ANY REMOVABLE PANEL WITH ELECTRICAL PARTS MUST BE GROUNDED.
 3. WHEN PASSING WIRES THROUGH METAL HOLES A GROMMET MUST BE USED

SHELF HEATER #1
2.9A @ 208VAC
1H84739

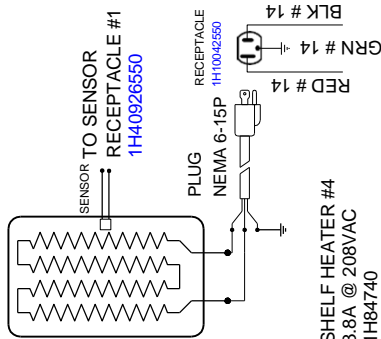

SHELF HEATER #2
2.9A @ 208VAC
1H84739

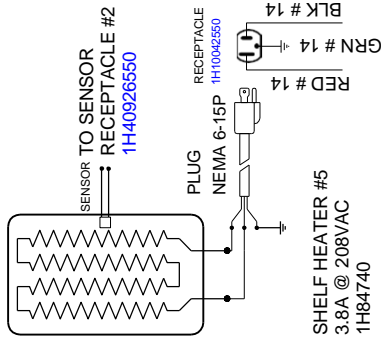

SHELF HEATER #3
2.5A @ 208VAC
1H84741

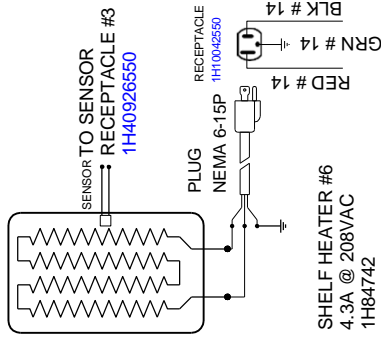

SHELF HEATER #4
3.8A @ 208VAC
1H84740

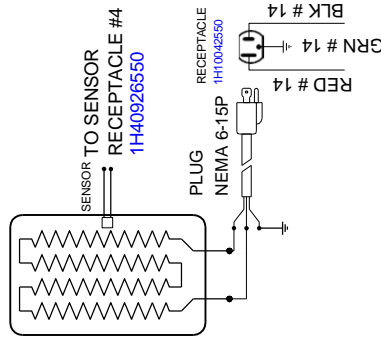

SHELF HEATER #5
3.8A @ 208VAC
1H84740

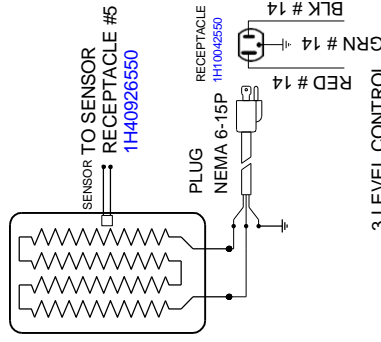

SHELF HEATER #6
4.3A @ 208VAC
1H84742

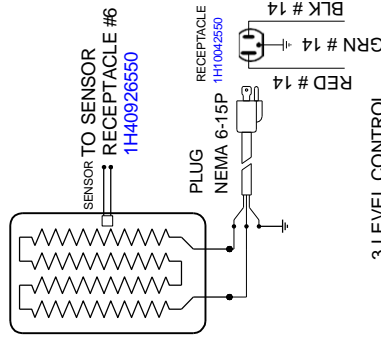

3 LEVEL CONTROL
1H40923550

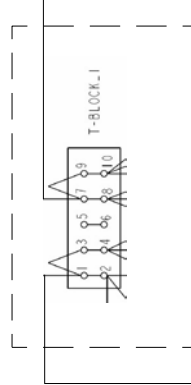

3 LEVEL CONTROL
1H40923550

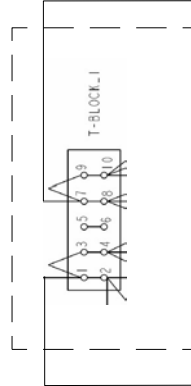

CIRCUIT #1

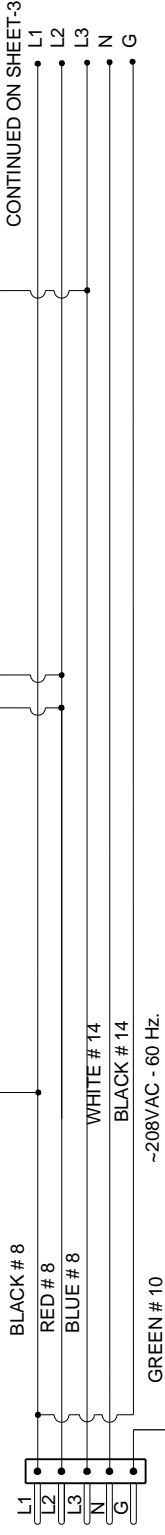

REVISIONS:

#	DESCRIPTION:	DATE:	BY:
B	CN#749653 ADDED HEATERS, FANS & LIGHTS	7/26/13	CB
C	CN#749653 MATCH PLM REVISION	10/2/13	CY
D	ECN-COD-0015279 REVISED CTRLR WIRING	3/11/22	CB

DRAWN BY: CRAIG BOOREY
CHECKED BY:

DATE:	3/26/13
PRODUCTION ORDER #:	523986
FILE LOCATION:	

PROJECT TITLE: TY-HOT
DRAWING TITLE: DIAGRAM - TY3-4X5E-H

CIRCUIT #1

LOADING	208 V	240V
L1	20.9	24.1
L2	25.5	29.4
L3	18.0	20.8

7733W @ 208VAC
10295W @ 240VAC

NOTE: CASE MUST BE GROUNDED

CIRCUIT # 1 CONTINUED

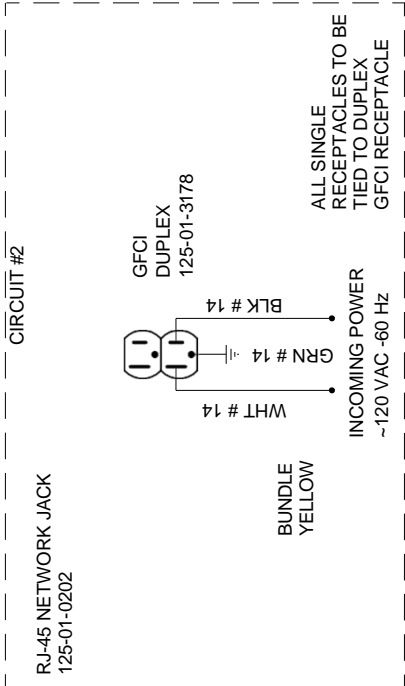

HEATER RECEPTACLE WIRING CONTROL PANEL

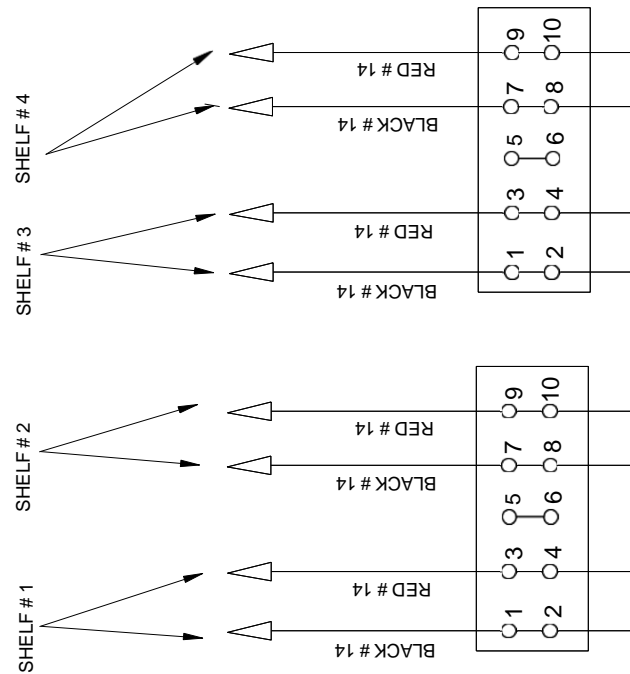

SENSOR RECEPTACLE WIRING CONTROL PANEL

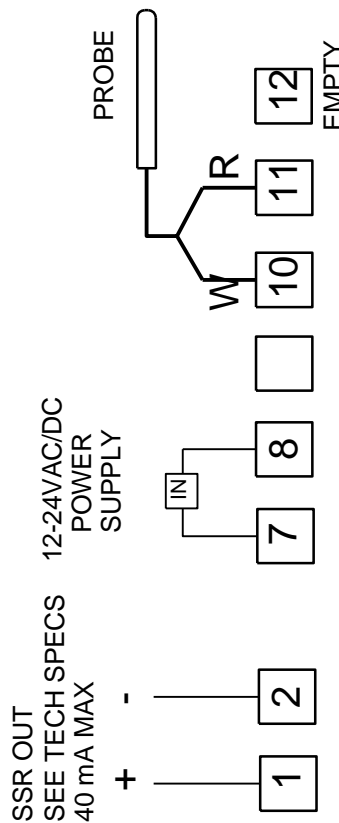

REVISIONS:

#	DESCRIPTION:	DATE:	BY:	CHECKED BY:
B	CN#749653 ADDED HEATERS, FANS & LIGHTS	7/26/13	CB	
C	CN#749653 MATCH PLM REVISION	10/2/13	CY	
D	ECN-COD-0015279 REVISED CTRLR WIRING	3/11/22	CB	

DRAWN BY: CRAIG BOOREY	PROJECT TITLE: TY-HOT	DRAWING #: W6600075
DATE: 3/26/13	PRODUCTION ORDER #: 523986	
FILE LOCATION:		

NOTE: CASE MUST BE GROUNDED

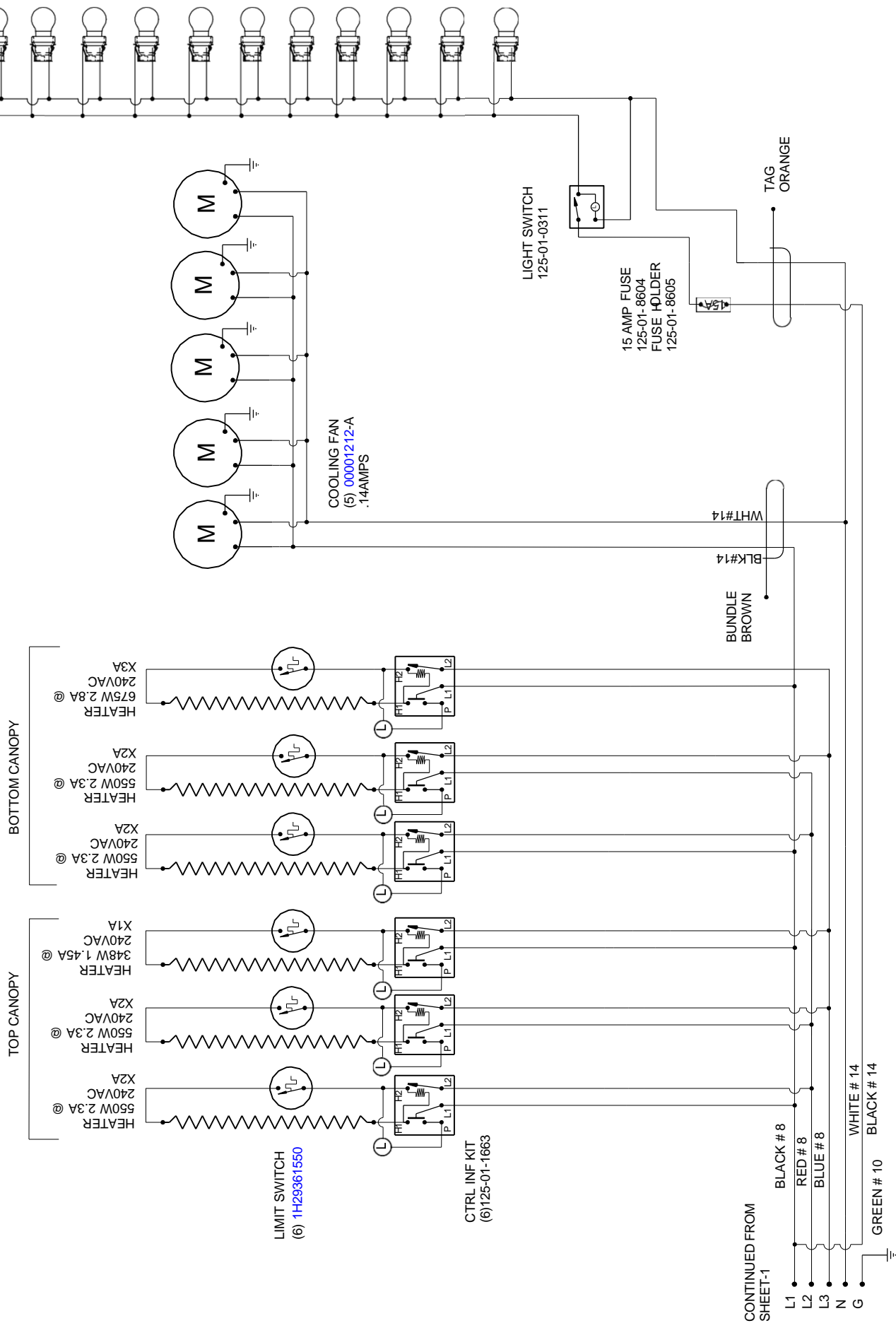

CONTINUED FROM SHEET-1

HUSMANN Husmann Corporation, Int'l 13770 Ramona Avenue Chino, CA. 91710 (809)-590-4910 Lic.#: 644406		REVISIONS:	DRAWN BY: CRAIG BOOREY	PROJECT TITLE: TY-HOT	DRAWING #: W6600075
#:	DESCRIPTION:	DATE:	CHECKED BY:	DATE:	
B	CN#749653 ADDED HEATERS, FANS & LIGHTS	7/26/13	CB	3/26/13	
C	CN#749653 MATCH PLM REVISION	10/2/13	CY	523986	DRAWING TITLE:
D	ECN-COD-0015279 REVISED CTRLR WIRING	3/11/22	CB		DIAGRAM - TY3-4X5E-H

CIRCUIT #1
LOADING

208V	240V
L1	17.5
L2	17.5
L3	13.0
	15.0

5764W @ 208VAC
7809W @ 240VAC

C	953643	20141025	CHANGED WIRE THICKNESS	05
D	EDCACA-0013876	201809205	REVISED GROUND WIRE	05
E	EDCACA-0015279	20220301	REVISED CTRL WIRING	05

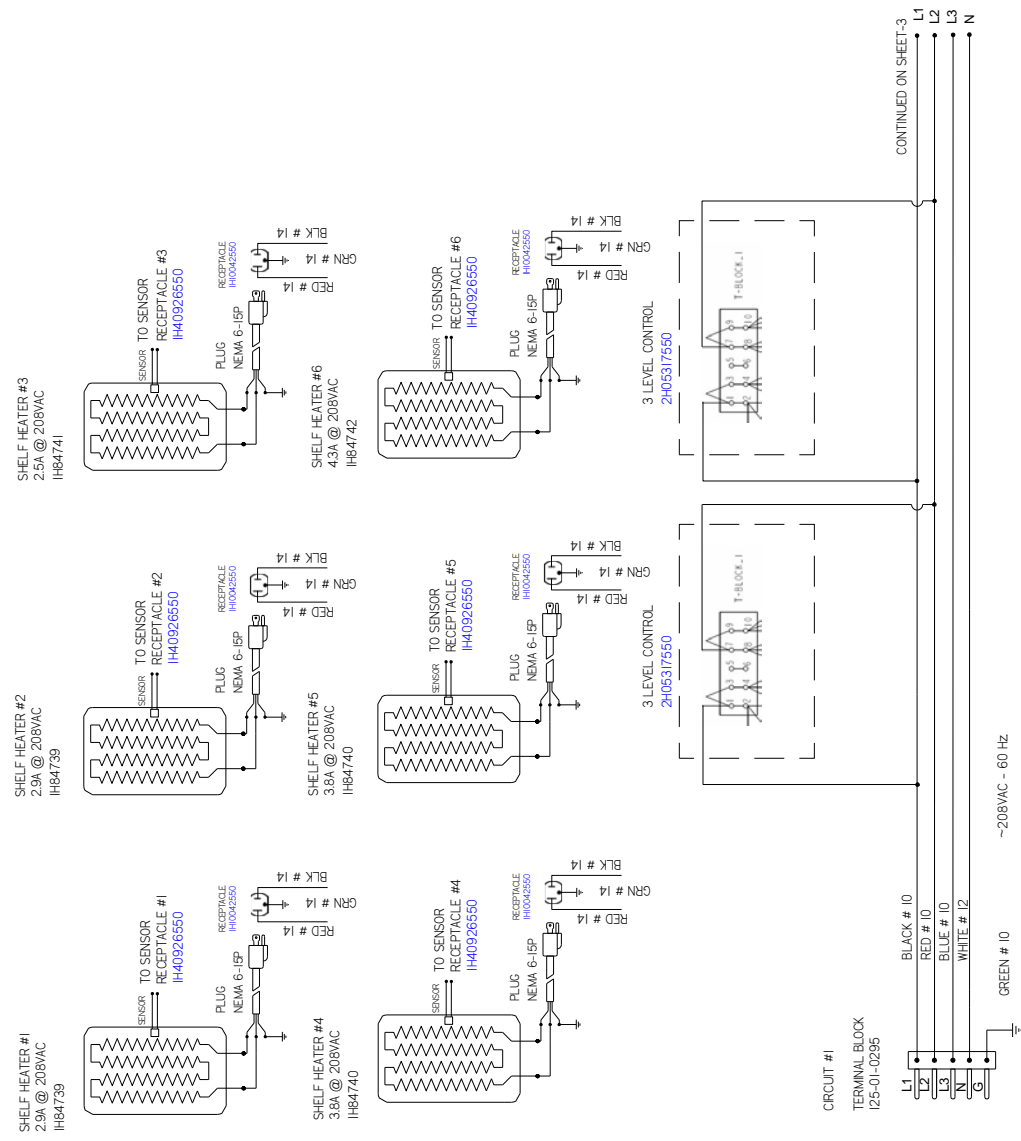

HUSSMANN
DIAGRAM-
TY3-4X5E-
H

DATE DRAWN - 10/16/13
DRAWN BY - CRAIG BOOREY
REVIEWED BY - CRAIG BOOREY
APPROVED BY - CRAIG BOOREY
UNLESS OTHERWISE SPECIFIED DIMENSIONS ARE IN INCHES
TOLERANCES ARE:
DECIMALS .XX +0.3 .XXX +0.10
ANG. E
ANGLES ± 2°

ECN# - 768011
REF - NEW DIAGRAM
SHEET 1 OF 3
THIRD PROJECTION

W6600103 E

NOTES
CASE MUST BE GROUNDED

C	9/2/2013	2014/10/25	CHANGED WIRE THICKNESS	05
D	EDM-CAP-001/876	2018/09/05	REVISED GROUND WIRE	05
E	EDM-COD-001/279	2022/03/11	REVISED CLR WIRING	05

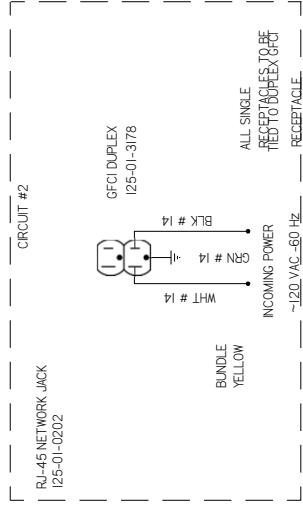

HEATER RECEPTACLE WIRING
CONTROL PANEL

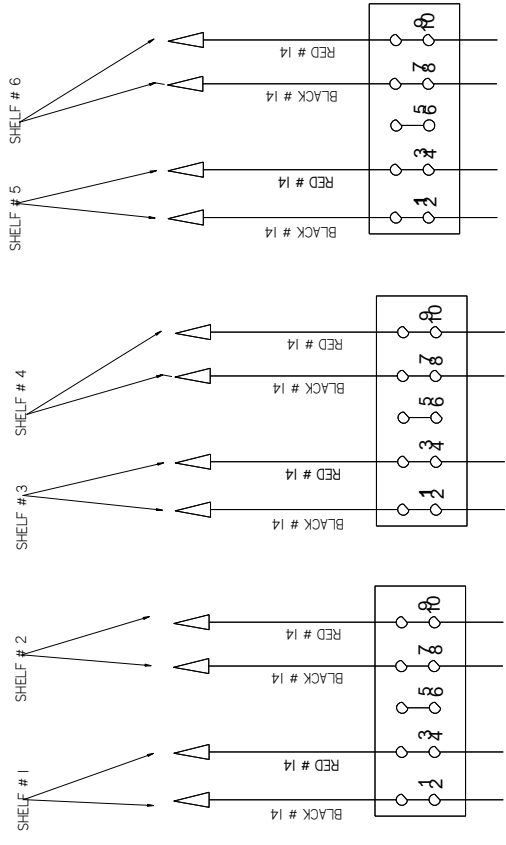

RECEPTACLE WIRING
SENSOR CONTROL PANEL

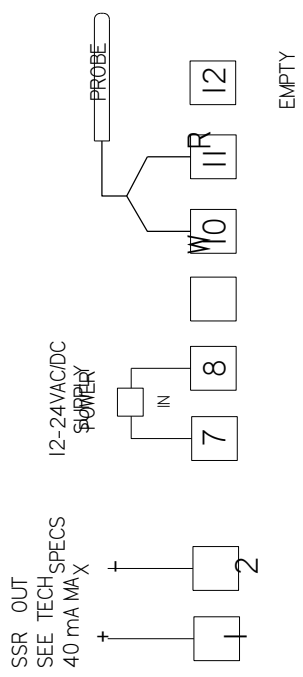

MATERIAL - N/A	
DATE DRAWN - 10/16/13	ECN# - 765011
DRAWN BY - CRAIG BOOREY	REF - NEW DIAGRAM
APPROVED BY - CRAIG BOOREY	SHEET 2 OF 3
UNLESS OTHERWISE SPECIFIED DIMENSIONS ARE IN INCHES.	
TOLERANCES ARE:	THIRD ANGLE PROJECTION
DECIMALS .XX ±0.0, .XXX ±0.0	
HUSSMANN	
DIAGRAM-	
TY3-4X5E-H	
W6600103	E

CASE MUST BE GROUNDED
NOTES

C	953643	20141125	CHANGED WIRE THICKNESS	03	03	03
D	EDN-CAP-0013876	20180926	REVISED GROUND WIRE	03	03	03
E	EDN-COD-0018279	20220301	REVISED CTRL WIRING	03	03	03

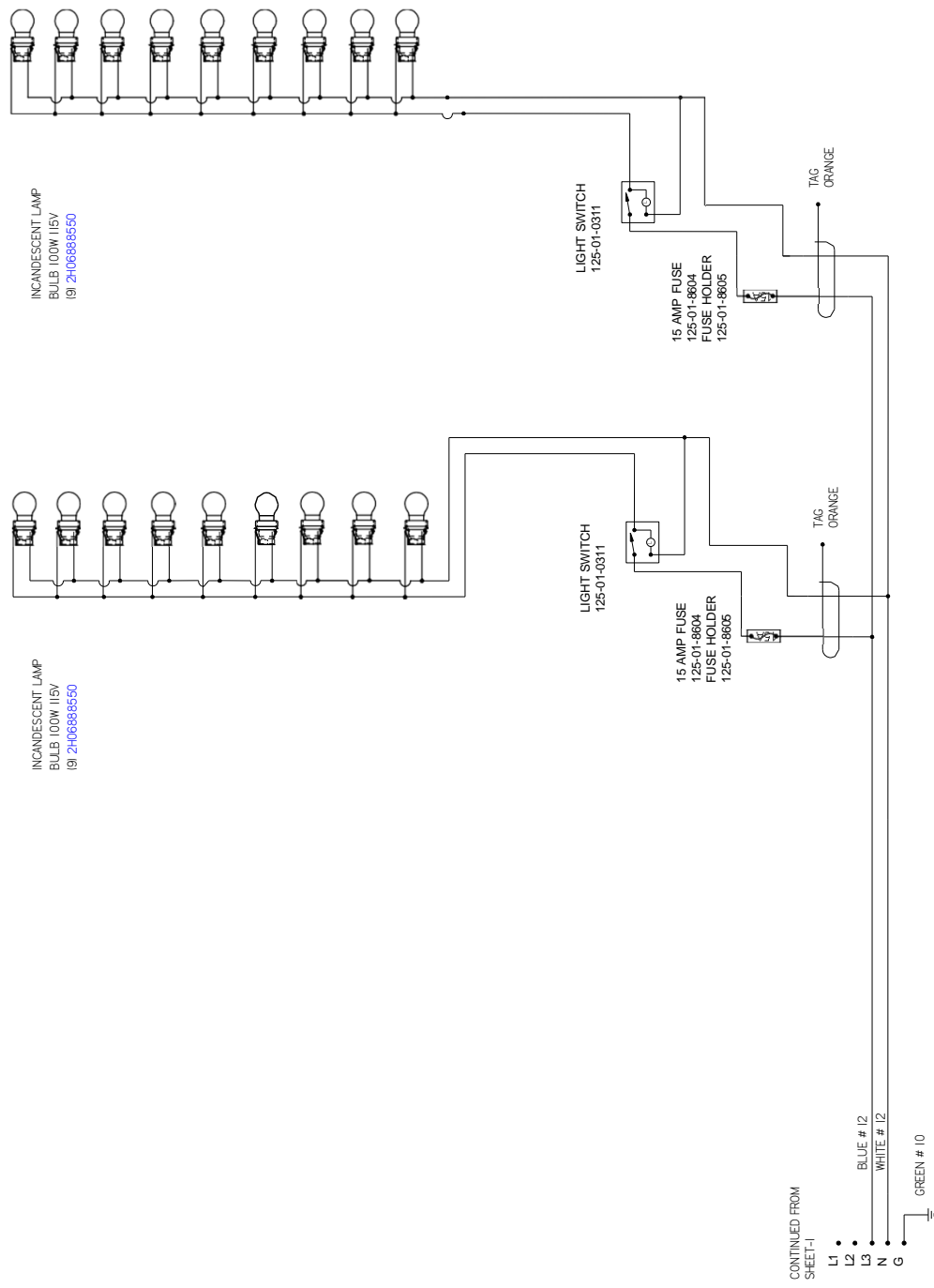

HUSSMANN
DIAGRAM-
TY3-4X5E-
H

MATERIAL - NA
DATE DRAWN - 10/16/13
DRAWN BY - CRAIG BOOREY
REVIEWED BY - CRAIG BOOREY
APPROVED BY - CRAIG BOOREY
UNLESS OTHERWISE SPECIFIED DIMENSIONS ARE IN INCHES
TOLERANCES ARE:
DECIMALS .XX +0.3 .XXX +0.10
ANGLES ± 2°

ECN# - 768011
REF - NEW DIAGRAM
SHEET 3 OF 3
THIRD

ANG.
E

PROJECTION

W6600103 E

NOTES:
CASE MUST BE GROUNDED



SELF SERVICE MULTI-DECK HOT CASE
HUSSMANN - TY3-4X

TY3-4-H Self-Service Hot End

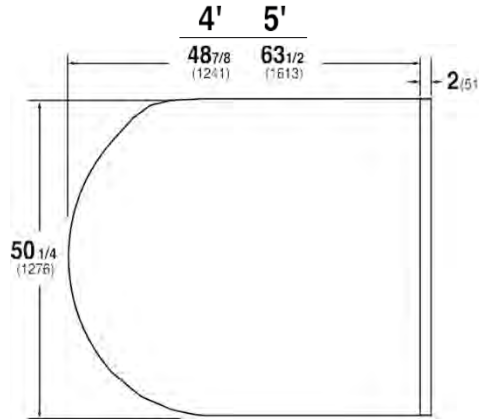
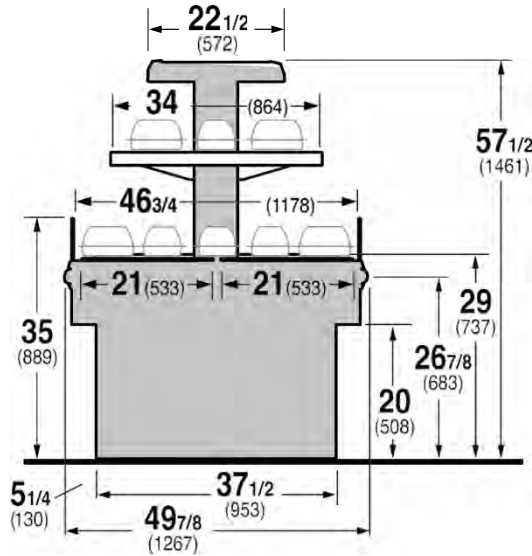

ELECTRICAL DATA:

208 VOLT MODELS	VOLTS	#H	H)	TOTAL HOT LEVELS ***	&ATTS *	AM#S L1	AM#S L2	AM#S L3	&IRES **
TY3-4X4E-H	208	3	60	2	4563	13.	13.	10.6	5
TY3-4X5E-H	208	3	60	2	5 64	1.5	1.5	13.0	5

240 VOLT MODELS	VOLTS	#H	H)	TOTAL HOT LEVELS ***	&ATTS *	AM#S L1	AM#S L2	AM#S L3	&IRES **
TY3-4X4E-H	240	3	60	2	606!	15.8	15.8	12.2	5
TY3-4X5E-H	240	3	60	2	80!	20.2	20.2	15.0	5

* INCLUDES INCANDESCENT LAM#S
 ** INCLUDES (ROUND &IRE
 *** TOTAL HEATED LEVELS * + RO&S OF SHELVES , 'OTTOM &ARMIN(SURFACE

LE(END		
N/A -	NOT AVAILABLE	
TBD -	TO BE DETERMINED	
SBO -	SUPPLIED BY OTHERS	
EXTERNAL END PANEL WIDTH KEY		
# O END PNLS	END PNL WIDTH (IN.)	FOYAL- ADDED LENGTH (IN.)
1	2.125	2.125
2	1.125	2.25

OPTION\$NOTES:

- 1%NOTE: CASE &IDTH INCLUDES END #ANELS &ITH O#TIONAL INTERIOR END #ANELS
- 2%NOTE: CASES MUST ' E (ROUNDED
- 3%NOTE: LED LI(HTS ARE NOT AVAILALE ON HOT CASES AT THIS TIME.

SELF-SERV CE HOT CASE

Cleaning and Maintenance

FOOD TEMPERATURES CAN BE ACCURATELY DETERMINED ONLY THROUGH THE USE OF FOOD THERMOMETERS!

Important Operation Tips:

- Preheat case 30 minutes before loading product using higher settings.
- Using thermometer, check product before loading in case (150°F-160°F).
- At start, set lamps to "3". After loading, recheck temperature every 1/2 hour to see that unit is operating properly. Adjust the thermostat (a higher number for hotter and a lower number for cooler) to maintain product temperature of 140°F (60°C) minimum. The setting will depend on the type of product being displayed. Be sure to test product temperature with a thermometer frequently for good product maintenance.
- Food should maintain contact directly with the "griddle" at all times.

Controls

There are three sets of controls for the hex case, each behind its own access panel located on the side of the case. The dial with the numbered settings is for the griddle. The other dials/switches are for the overhead lights and heating components.

Overhead Heating System

Cal rod units are located above the griddles to provide top heat. **To obtain the proper food temperatures, they must be adjusted. Settings may vary depending on food composition. Maximum limits should be avoided to prevent overcooking or drying out food.**

General Cleaning Rules

1. Turn temperature control knobs to OFF position.
2. ALLOW SURFACES TO COOL BEFORE HANDLING.
3. Wipe entire unit with clean cloth and mild detergent. The EXTERIOR surfaces of these hot tables must be cleaned with a mild detergent and warm water to protect and maintain their attractive finish. Never use abrasive cleaners or scouring pads.
2. Clean frequently and regularly.
3. Rinse thoroughly after cleaning.
4. Remove surface spills immediately with a damp cloth.

TO REMOVE "BAKED-ON" SPLATTER, GREASE OR LIGHT DISCOLORATION TO STAINLESS STEEL.

<u>CLEANSING AGENT</u>	<u>APPLICATION</u>
Grade F Italian Pumice.....	Scour or rub with damp cloth
Liquid NuSteel.....	Scour with small amount on dry cloth

Paste NuSteel

Household Cleansers.....Rub with damp cloth

TO REMOVE HEAT TINT OR HEAVY DISCOLORATION

<u>CLEANSING AGENT</u>	<u>APPLICATION</u>
Allen Stainless Steel Polish.....	Small amount on damp cloth
Birdsall "Staybright"	Rub with damp cloth
Wyandotte	
Bab-O	
Nusteel.....	Rub with stainless steel wool

Glass Care

Cleaning

Clean with plenty of nonabrasive soap (or detergent) and lukewarm water, using the bare hand to feel and dislodge any caked-on dirt. A soft, grit-free cloth, sponge, or chamois may be used, but only as a means of carrying the water to the plastic. Dry with a clean damp chamois or clean soft cloth such as cotton flannel. Hard, rough cloths or paper towels will scratch the acrylic and should not be used.

Stainless Steel Cleaning and Care

There are three basic things, which can break down your stainless steel's passivity layer and allow corrosion.

1. Mechanical Abrasion
Mechanical Abrasion means those things that will scratch the steels surface. Steel Pads, wire Brushes, and Scrapers are prime examples.
2. Water
Water comes out of our tap in varying degrees of hardness. Depending on what part of the country you live in, you may have hard or soft water. Hard water may leave spots. Also, when heated, hard water leaves deposits behind that if left to sit, will break down the passive layer and rust your stainless steel. Other deposits from food preparation and service must be properly removed.
3. Chlorides
Chlorides are found nearly everywhere. They are in water, food and table salt. One of the worst perpetrators of chlorides can come from household and industrial cleaners.

Cleaning and Maintenance

Don't Despair! Here are a few steps that can help prevent stainless steel rust.

1. Use the Proper Tools

When cleaning your stainless steel products, take care to use non-abrasive tools. Soft Clothes and plastic scouring pads will NOT harm the steel's passive layer. Stainless steel pads can also be used but the scrubbing motion must be in the same direction of the manufacturer's polishing marks.

2. Clean With the Polish Lines

Some stainless steels come with visible polishing lines or "grain". When visible lines are present, you should ALWAYS scrub in a motion that is parallel to them. When the grain cannot be seen, play it safe and use a soft cloth or plastic scouring pad.

3. Use Alkaline, Alkaline Chlorinated or Non-chloride Containing Cleaners

While many traditional cleaners are loaded with chlorides, the industry is providing an ever increasing choice of non-chloride cleaners. If you are not sure of your cleaner's chloride content contact your cleaner supplier. If they tell you that your present cleaner contains chlorides, ask for an alternative. Also, avoid cleaners containing quaternary salts as they also can attack stainless steel & cause pitting and rusting.

4. Treat your Water

Though this is not always practical, softening hard water can do much to reduce deposits. There are certain filters that can be installed to remove distasteful and corrosive elements. Salts in a properly maintained water softener are your friends. If you are not sure of the proper water treatment, call a treatment specialist.

5. Keep your Food Equipment Clean

Use alkaline, alkaline chlorinated or non-chlorinated cleaners at recommended strength. Clean frequently to avoid build-up of hard, stubborn stains. If you boil water in your stainless steel equipment, remember the single most likely cause of damage is chlorides in the water. Heating cleaners that contain chlorides has a similar effect.

6. RINSE, RINSE, RINSE

If chlorinated cleaners are used you must rinse, rinse, rinse and wipe dry immediately. The sooner you wipe off standing water, especially when it contains cleaning agents, the better. After wiping the equipment down, allow it to air dry for the oxygen helps maintain the stainless steel's passivity film.

7. Never Use Hydrochloric Acid (Muriatic Acid) on Stainless Steel

8. Regularly Restore/Passivate Stainless Steel

Cleaning and Maintenance



DANGER

ALWAYS DISCONNECT ELECTRICAL POWER AT THE MAIN DISCONNECT WHEN SERVICING OR REPLACING ANY ELECTRICAL COMPONENT. This includes (but not limited to) Fans, Heaters, Thermostats, and Lights.

Replacing Overhead Heat Lamps

Overhead Halogen and Merco lamps are designed to last through many hours of use. Should there be a need to replace one, it is as simple as replacing a standard fluorescent light bulb.



CAUTION

The Heat lamps used in these cases get EXTREMELY HOT! NEVER touch a lamp until the case has had ample time to cool down! It is also highly recommended to handle lamps with gloves or use a cloth rag - not just for the heat factor, but also the oils in your fingers will drastically shorten the life of the lamp.

1. Turn light switch to OFF before replacing any lighting components.
2. Disconnect light fixture by removing power cord from socket in the right rear interior corner of the merchandiser.
3. Place the shelf on a flat surface to remove the clear plastic protective shield from the fixture. Carefully insert one finger between the fixture socket and the protective shield. Use other hand to "pinch" lens cover (and simultaneously hold the fixture in place) while lifting with inserted finger. When shield separates from fixture at one end, remove it by SLOWLY pulling remainder of shield away from fixture.
4. Remove lamp by depressing spring loaded socket at end of fixture, and swinging opposite end of lamp from it's former position.
5. Using gloves or covering for lamp, insert new lamp into spring loaded socket, depressing socket until opposite end of lamp properly enters stationary light socket.
6. Return lamp to original position by lightly pinching it in from each side, and inserting shield flanges into fixture channel. Continue process along length of lamp shield until it is in it's final proper position.
7. Return lamp to original position by lightly pinching it in from each side, and inserting shield flanges into fixture channel. Continue process along length of lamp shield until it is in it's final proper position.

TY Hot Maintenance

General

The Hatco Glo-Ray Heated Shelf Units are designed for maximum durability and performance with minimum maintenance.



ELECTRIC SHOCK HAZARD:

- Turn the power switch OFF, unplug the power cord, and allow the unit to cool before performing any maintenance or cleaning.
- DO NOT submerge or saturate with water. Unit is not waterproof. Do not operate if unit has been submerged or saturated with water.

Cleaning

To preserve the finish of the Glo-Ray Heated Shelf, it is recommended that the surfaces stains may be removed with a non-abrasive cleaner. Hard to reach areas should be cleaned with a small brush and mild soap.

NOTICE

Use non-abrasive cleaners only. Abrasive cleaners could scratch the finish of the unit, marring its appearance and making it susceptible to soil accumulation.

CAUTION

CLEANING PRECAUTIONS

When cleaning:

- Do not use high pressure water hoses
- Do not introduce water faster than waste outlet can drain
- NEVER INTRODUCE WATER ON SELF CONTAINED UNIT WITH AN EVAPORATOR FAN
- NEVER USE A CLEANING OR SANITIZING SOLUTION THAT HAS AN OIL BASE (these will dissolve the butyl sealants) or an AMMONIA BASE (this will corrode the copper components of the case)
- TO PRESERVE THE ATTRACTIVE FINISH:
- DO USE WATER AND A MILD DETERGENT FOR THE EXTERIOR ONLY
- DO NOT USE A CHLORINATED CLEANER ON ANY SURFACE
- DO NOT USE ABRASIVES OR STEEL WOOL SCOURING PADS (these will mar the finish)

Service Record

Last service date: By:

_____	_____
_____	_____
_____	_____
_____	_____
_____	_____
_____	_____
_____	_____

HUSSMANN®/Chino

Additional copies of this publication may be obtained by contacting:

Hussmann® Chino
13770 Ramona Avenue • Chino, California 91710
(909) 628-8942 FAX
(909) 590-4910
(800) 395-9229

www.hussmann.com

The *MODEL NAME* and *SERIAL NUMBER* is required in order to provide you with the correct parts and information for your particular unit.

They can be found on a small metal plate on the unit. Please note them below for future reference.

MODEL:

SERIAL NUMBER: