

STLHR

Operators Manual



MODEL:
HRF4-0

Hydra Rinse® Cleaning and Sanitizing System
for Soft Serve Ice Cream Machines

HYDRA RINSE®

CLEANS SIMPLE. SAFE. QUICK.

Complete for service reference information regarding your Hydra Rinse® product:**Model Number:** _____**Serial Number:** _____**Catalog Number:** _____**Soft Serve Machine Model Number:** _____**FCC Compliance Statement:**

Note: This equipment has been tested and found to comply with the limits for a Class A digital device, pursuant to part 15 of the FCC Rules. These limits are designed to provide reasonable protection against harmful interference when the equipment is operated in a commercial environment. This equipment generates, uses, and can radiate radio frequency energy and, if not installed and used in accordance with the instruction manual, may cause harmful interference to radio communications. Operation of this equipment in a residential area is likely to cause harmful interference in which case the user will be required to correct the interference at his own expense.

ISED Compliance Statement:

This device contains licence-exempt transmitter(s)/receiver(s) that comply with Innovation, Science and Economic Development Canada's licence-exempt RSS(s). Operation is subject to the following two conditions:

1. This device may not cause interference.
2. This device must accept any interference, including interference that may cause undesired operation of the device.

L'émetteur/récepteur exempt de licence contenu dans le présent appareil est conforme aux CNR d'Innovation, Sciences et Développement économique Canada applicables aux appareils radio exempts de licence. L'exploitation est autorisée aux deux conditions suivantes :

1. L'appareil ne doit pas produire de brouillage;
2. L'appareil doit accepter tout brouillage radioélectrique subi, même si le brouillage est susceptible d'en compromettre le fonctionnement.

STLHR

NSF listed as HRF4-0 under Hydra Rinse, LLC

Any unauthorized reproduction, disclosure, or distribution of copies by anyone unaffiliated with HYDRA RINSE, LLC relating to any portion of this work may be a violation of Copyright Law of the United States of America and other countries. Statutory Damages of up to \$150,000 (17 USC 504) could result for infringement, which could also lead to consequent civil and criminal penalties. All rights reserved.

Hydra Rinse, LLC 7870 Lehigh Crossing Suite 1, Victor New York 14564

Toll Free: 844-233-6349

Table of Contents

	Page
Section 1: Installation Guidelines	1
Section 2: Operator Introduction	2
Section 3: Safety	3
Section 4: Product Introduction.....	4
• The Hydra Rinse® Eco System	
Section 5: User Interface	5
• The RESET-CUPS-PROGRAM button functionality	
• The ONE TOUCH button functionality	
• The STATUS INDICATORS LEDs	
• The PLAY/PAUSE button functionality	
Section 6: LEXX™ Cups and Gallon Concentrate	7
• LEXX™ Liquid Sanitizer and Cleaner Concentrate	
Section 7: Registration of Token Tag	8
Section 8: Referenced Components	9
Section 9: Required Water and Drain Source	10
• Water Source	
• Drain Source	
Section 10: HRWAND128 Portable Wandstation.....	11
• General Information	
Section 11: Upgraded Components.....	12
• Hydra Rinse® Upgraded Components	
Section 12: NSF Certified Hydra Rinse® Process.....	13
• 28 Step Reference Document	

Table of Contents

	Page
Section 13: NSF Certified Flavor Change Process.....	14
• 29 Step Reference Document	
Section 14: Details of the Hydra Rinse® Process	15
• Detailed Training Instructions for Sections 12 & 13	
Section 15: Troubleshooting Guide	28
• Table Defining Common Problems with Potential Cause and Solution	
Section 16: Pro-control Module LEDs	30
• Table Defining LED Process and Error Codes	
Section 17: Battery Installation/Replacement	32
Section 18: Online Resources/Support	33
Section 19: Warranty.....	34
Section 20: Appendix A.....	35
• LEXX™ pH Solution Measurement	
• LEXX™ Solution Total Acid Test	

Section 1: Installation Guidelines

The information provided is to ensure that your STLHR meets factory tested Performance.

Requirements



No additional tools or fasteners are required for proper mounting to the soft serve machine; attaching features are all inclusive.

For the **WSF128-169 Portable Wandstation "HRWAND128"**: Depending on where the location of the "MOUNTING BRACKET" is installed e.g. concrete/drywall, etc., anchor bolts (**not included**) should be capable of supporting a minimum of 50 lbs. (Max screw diameter 3/16" actual size: 0.1875")

Care should be taken when installing your STLHR to ensure proper performance and operation.

- Only STLHR trained personnel should install and operate this device.
- Only Authorized STLHR service personnel should make any necessary repairs

Note: *STLHR is engineered to work exclusively with LEXX™ Liquid Sanitizer and Cleaner Concentrate.*

Protective Measures



Never submerge the Pro-control Module into any liquid. This product was manufactured and designed to meet IP65 standards:

- 6: Totally protected from dust contaminates.
- 5: Protected against low pressure jetting from water in all directions, limited ingress permitted.

Site Pre-requisite



Water supply must be >50 PSI, capable of flowing a minimum of 4.5 GPM, having a sanitary pH value of ~7.0-8.0.



We also recommend using a **Water Softener** to minimize hard water impact on the entire Hydra Rinse® Eco System.

Water Connection



Recommended outlet water temperature 110°F (43.3°C) but less than 120°F (48.9°C); Default: 112.5°F (44.7°C).

Note: No more than 120°F (48.9°C). Damage will occur to the Pro-control Module.

A backflow prevention device is required (**Not Included**) for the inlet water connection. Refer to applicable National, Federal, State, and local codes.

Specific State Requirements:

California (CA) Code: (Backflow Prevention, RPP)

Installed Backflow prevention device must meet or exceed specifications of Watts 9D Dual Check Valve(s) with intermediate Atmospheric Vent.

Section 2: Operator Introduction

The following Hydra Rinse® product: STLHR has been carefully engineered and manufactured to give you consistent operation.

To the Operator

Careful maintenance and operation of this unit will ensure product quality and consistent performance. The STLHR will require frequent cleaning of the unit itself. Please take care in understanding the outlined procedures in this manual.

Important Messages



For optimal results, follow the cleaning and sanitizing procedures for both Sections 12 and 13 without "**Interruption**".

Using Hydra Rinse® does not eliminate the present concerns associated with manual cleaning and sanitizing procedures:

Soft serve machines must never be placed in "**Freeze Mode**" in place of "**Clean Mode**" for any type of cleaning and sanitizing process. When the freezing barrel(s) become filled with cleaning and/or sanitizing solution as a replacement for product mix, permeant damage can and most likely will occur to the freezing cylinders if the solution is allowed to freeze, causing the soft serve machine to become inoperable. So, when asked to place the machine into "**Clean Mode**" during the Hydra Rinse® process, be sure to never select "**Freeze Mode**".

State Considerations:

(Included with HRWAND128 or LBUDDYSR): With every STLHR is a LEXX™ pH Test Strip Kit. The test strip is used for measuring the acceptable range of pH for proper sanitization (strip should indicate less than 3.5pH).

For States requiring a total citric acid concentration (grams/Liter) semi-quantitative measurement (**Sold separately**). Use QUANTOFIX® Total acid part no. 91353 (Strip should indicate between 2.0-2.5 g/L)

Note: *Warranty is valid if authorized STLHR parts are acquired from an authorized STLHR Distributor/Reseller along with service work being performed by an authorized STLHR service technician. Hydra Rinse® reserves any right to deny warranty claims on device or parts if unofficial STLHR components were installed in the unit. This also applies to any modifications that fall out of the scope of factory recommendations, apparent abuse, or neglect.*

Note: *STLHR is under continuous research and engineering; any improvements to our product will lead to information changes within this manual and are subject to change without notice (www.hydrarinse.com).*



Battery Disposal:

Hydra Rinse® is powered by 3 C Dry Cell Batteries

- **Do Not** place in fire or incinerator.
- **Do Not** dispose in refuse.
- **Do** remember to recycle in accordance with local regulations.



Section 3: Safety



Implementation with any one of our products requires a thorough understanding of factory recommendations; complete knowledge of this Operators Manual is recommended.

Important Message



Failures to adhere to the listed safety precautions may result in severe personal injury or even death. Personal, unauthorized service or repairs to this unit may result in inadvertent damages, and excessive service repair expense.

Visual Inspection



As a good practice, please take time to periodically inspect components for unforeseeable issues that may arise due to wear or damage (e.g., Water lines, supply hoses). Hoses can be an obstacle resulting in tripping and/or falling hazards that result in injury. Always work carefully around hoses avoiding injury to anyone within direct and/or indirect contact.

Water can wreak havoc with compromised systems, especially with unprotected surroundings like electrical receptacles that are unprotected by ground fault circuit interruption (GFCI). Worn out extension cords can lead to electrical shock when exposed to water.

Water/ Temperature



Do not operate the STLHR with water temperatures above 120°F (48.9°C) is not recommended; burns will occur from over exposure.

Batteries



The Pro-control Module is designed for non-rechargeable batteries. Regular "C DRY CELL BATTERIES" can be exposed to some water for a short period of time: If this is the case, make sure batteries are completely dry before inserting into the Pro-control Module Battery Case.

Never change or remove the batteries when water is present. Find a dry, clean area when replacing batteries. Since the Pro-control Module is always around water, never substitute "DRY CELL BATTERIES" for any rechargeable batteries i.e., li-ion; use of Professional Alkaline Batteries is suggested.

If water enters the Pro-control Module Housing, discontinue usage immediately. Allow unit to air dry for 2 to 3 hours. If unit fails to operate correctly, replacement will be required; this failure is not covered under warranty.

WSF128-169 Portable Wandstation "HRWAND128"

Never directly point the wand at anyone, for any reason. Never insert the Wand Tip into any orifice of any food dispensing device while beaters are in motion and/or electrically powered food equipment that may allow access to electrical circuitry/ components. When possible, always power off equipment before servicing to avoid electrocution/damage to device.

Section 4: Product Introduction

The Hydra Rinse® Eco System is comprised of a plurality of Hydra Rinse® products designed to work exclusively with ProNatural Brands® naturally derived LEXX™ Liquid Sanitizer and Cleaner Concentrate (LEXX™). The Hydra Rinse® Eco System was designed for cleaning food dispensing equipment i.e., soft serve ice cream machines.

When you bring more components of The Hydra Rinse® Eco System into your cleaning process, the more time and money you begin to save while promoting a standardized cleaning solution for end users.

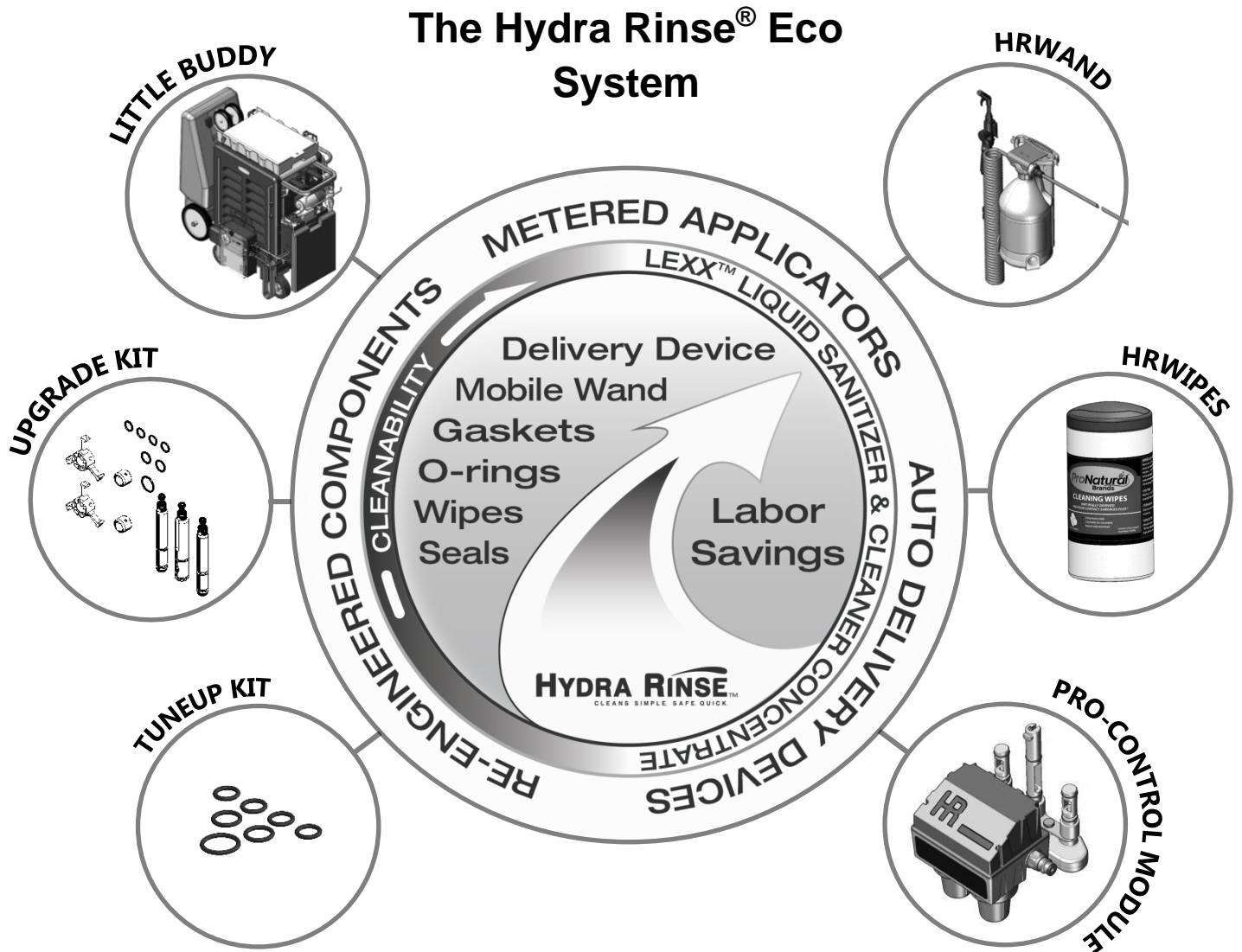

Ask your participating Distributor/Reseller for more information about Hydra Rinse® products and their applications.

Section 5: User Interface 1 of 2

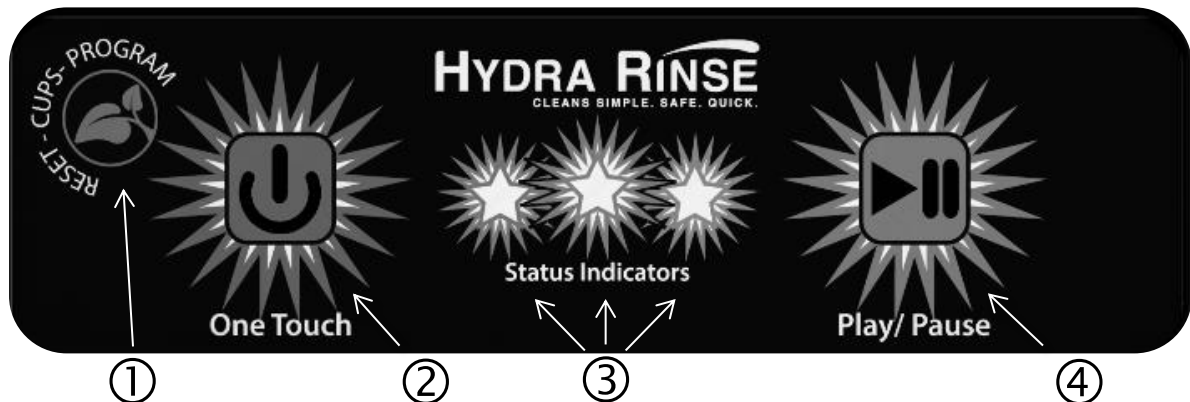

① The “RESET-CUPS-PROGRAM” button functionality:

- Reset the Pro-control Module processor/Read Firmware version
- Register cleaning/sanitizing cycles
- Read number of cleaning/sanitizing cycles available

② The “ONE TOUCH” button functionality:

- Initialize cleaning/sanitizing cycles
- Conclude cleaning/sanitizing cycle
- Self-clean mode when used simultaneously with the “PLAY/PAUSE” button

③ The “STATUS INDICATORS” LEDs:

- Power On/Cycle initiated
- Specific process codes
- Firmware Version
- Cycle paused
- Battery Low/Replacement Required
- Errors
- Number of registered cleaning/sanitizing cycles
- Cycle complete

④ The “PLAY/PAUSE” button functionality:

- Cancel initiated cleaning/sanitizing cycle
- Pause/Resume cleaning/sanitizing cycle
- Self-clean mode when used simultaneously with the “ONE TOUCH” button

Section 5: User Interface 2 of 2

An audible “BEEP” may also accompany many of the Status Indicator LED patterns. Audible sounds indicate to the end users that some kind of action may need to be taken e.g., place soft serve machine in “WASH/CLEAN MODE”, pause cycle for full teardown of the soft serve machine, batteries need to be replaced, some error needs to be resolved before operations can continue.

Section 16: “Pro-control Module LEDs” includes a table that breaks down the different patterns of the Status Indicator LEDs, along with descriptions and specific actions that may be required by the end user.

A unique function of the Status Indicators helps with registering/reading a “TOKEN TAG”. The Status Indicators will “BLINK” out the number of cleaning/sanitizing cycles stored inside the Pro-control Module when enabled.

For instance, the “GREEN LED” will represent the hundreds place, the “YELLOW LED” will represent the tens place and the “RED LED” will represent the ones place

e.g., 136 stored cycles are represented with 1 Green blink, 3 Yellow blinks and 6 Red blinks, indicating 136 available cycles are stored inside the unit.



Section 6: LEXX™ Cups and Gallon Concentrate

● “LEXX™ Liquid Sanitizer and Cleaner Concentrate” is the steam engine behind the Hydra Rinse® Process. Its naturally derived ingredient provides for incredible efficiency, it also has no negative impact on product mix or residual taste when used as directed. Not only is it tasteless, but it also doesn’t require rinsing after application. LEXX’s ability to remove and prevent milkstone will be evident with every application.

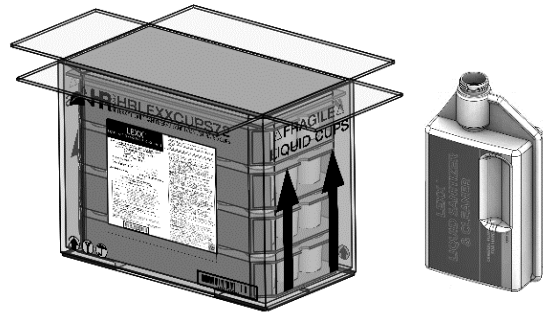

The Hydra Rinse® System requires different products of the same formulation: The “LEXX™ CUPS”, which come 72 per box provide for 36 automated cleaning cycles; one cup (2 fl. oz.) for cleaning and one cup (2 fl. oz.) for sanitizing. The “MEASURE & POUR BOTTLES” provides for 32 automated cleaning cycles: 2 fl. oz. for cleaning and 2 fl. oz. for sanitizing.

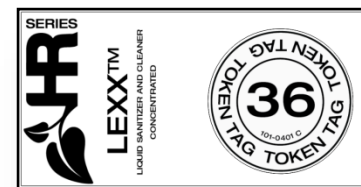

(Illustration of TOKEN TAG for LEXX™ cups)

The “LEXX™ CUPS” comes with a 36 cycle “TOKEN TAG”, and the Measure & pour bottles come with a 32 cycle “TOKEN TAG”. The token tag is registered with the Pro-control Module. This step ensures the Hydra Rinse® Process is using the specific sanitizer/cleaner it was created for; end user safety, Hydra Rinse® cleaning and sanitizing results depend on **LEXX™ Liquid Sanitizer and Cleaner Concentrate**.

● There is also the 1 Gallon version of **LEXX™ Liquid Sanitizer and Cleaner Concentrate**. The 1 Gallon container directly attaches to the HRWAND128.

The HRWAND128 will be used to perform many of the cleaning/sanitizing tasks within the Hydra Rinse® Process.



Section 7: Registration of Token Tag

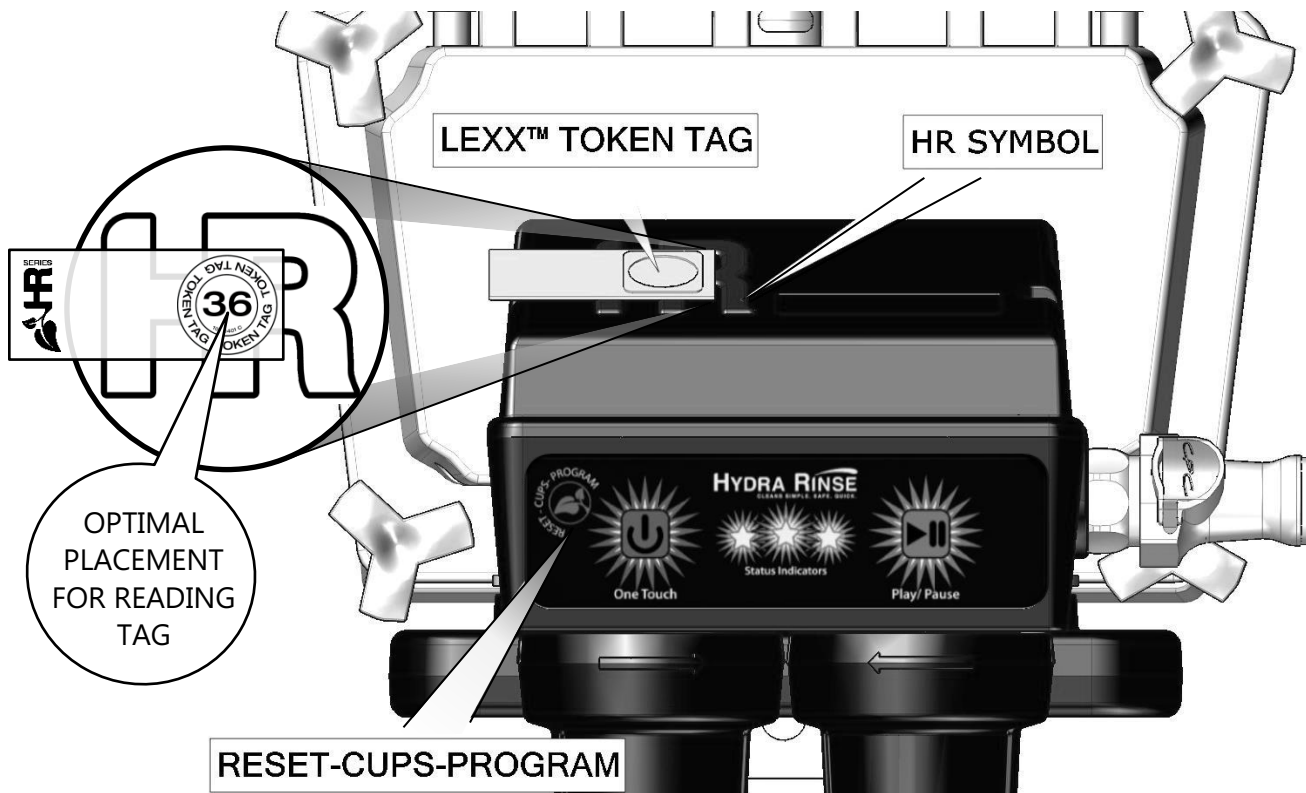

(For reading out number of available cycles, use an old/previous registered "TOKEN TAG"!)

Before the Pro-control Module can be put into operation, first install batteries (Section 17: Battery Replacement) followed by registration of the "TOKEN TAG". The "TOKEN TAG" can be found inside either box of "LEXX™ CUPS" or "LEXX™ MEASURE AND POUR"; more specifically it's directly attached to the LEXX™ Liquid Sanitizer and Cleaner Concentrate product insert card.

To register your new sanitizer/cleaner, simply hold the "TOKEN TAG" up against the "HR SYMBOL" located on the top cover of the Pro-control Module as illustrated; placing the portion of the Token Tag that contains the printed number of cycles up against the "HR SYMBOL" i.e., exactly in the center of the "HR SYMBOL" as illustrated.

While holding the "TOKEN TAG" in position, whether for registering or reading, press and then release the "RESET-CUPS-PROGRAM" button; the LEDs will begin to illuminate. Once the "TOKEN TAG" has been successfully registered a "BEEP" will be heard, followed by the "STATUS INDICATORS" blinking out the number of stored cycles within the Pro-control Module.

To conclude the "TOKEN TAG" registration process, once again press and then release the "RESET-CUPS-PROGRAM" button, but this time without the "TOKEN TAG" present. This will reset the Pro-control Module rendering it ready for use.

Section 8: Referenced Components

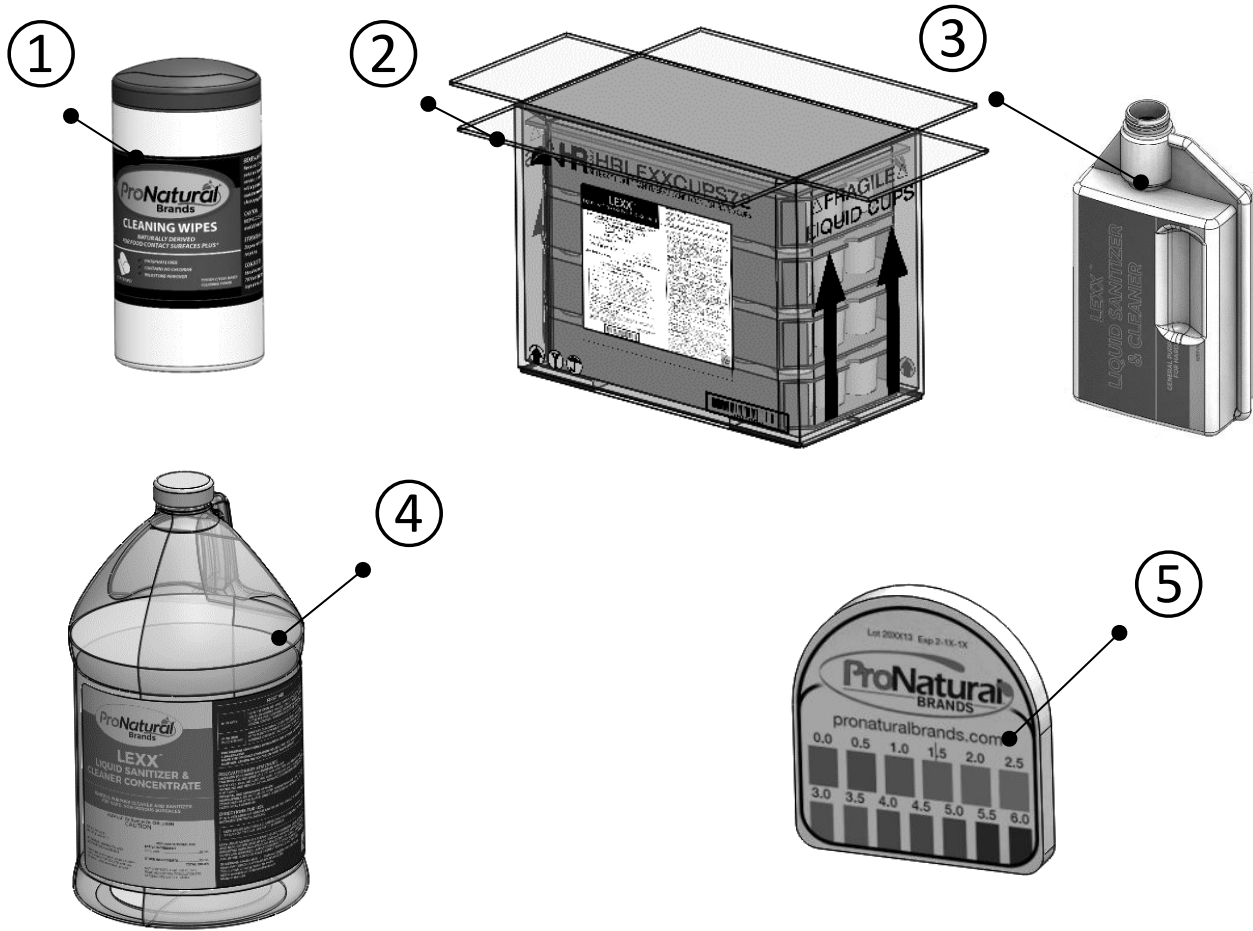

IMAGES FOR ILLUSTRATION ONLY

Item:	Description:
01	PRONATURAL® CLEANING WIPES
02	LEXX™ CUPS
03	LEXX™ MEASURE AND POUR LIQUID SANITIZER AND CLEANER CONCENTRATE BOTTLE
04	LEXX™ LIQUID SANITIZER AND CLEANER CONCENTRATE
05	LEXX™ pH TEST STRIPS (Included with Wand Products)

Section 9: Required Water and Drain Source

● WATER SOURCE:

It's important to have proper water pressure, water flow and water temperature (**Section 1: Installation Guidelines**). To ensure water temperature stays constant during the automated sequence, a "TEMPERATURE MIXING VALVE" (1) is recommended; must be installed in accordance with all applicable Local, State, National and Provincial Codes, Ordinances, Regulations and Laws.

Once the "FITTING, Y-GHT SPLITTER" item (17) is snug fitted to the "TEMPERATURE MIXING VALVE" item (1), continue to rotate the female GHT fitting counterclockwise for an additional 90-110° to insure a good tight fit. Repeat the same process for installing both the "25 FOOT POLYURETHANE 3/8" O.D. WATER SUPPLY ASSEMBLY" item (16) and for the combined "5 FOOT HOSE ASSEMBLY/EXTENDED WATER SUPPLY HOSE" item (15).

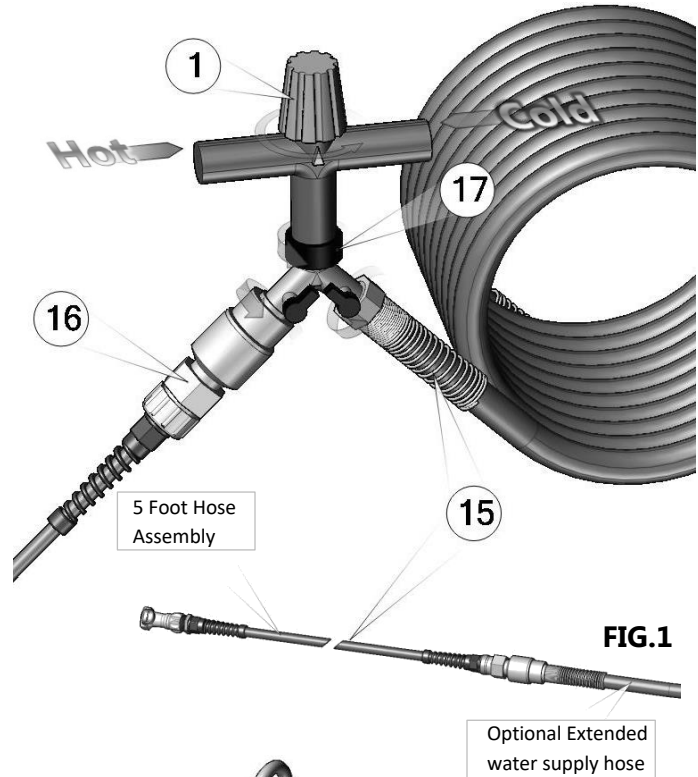
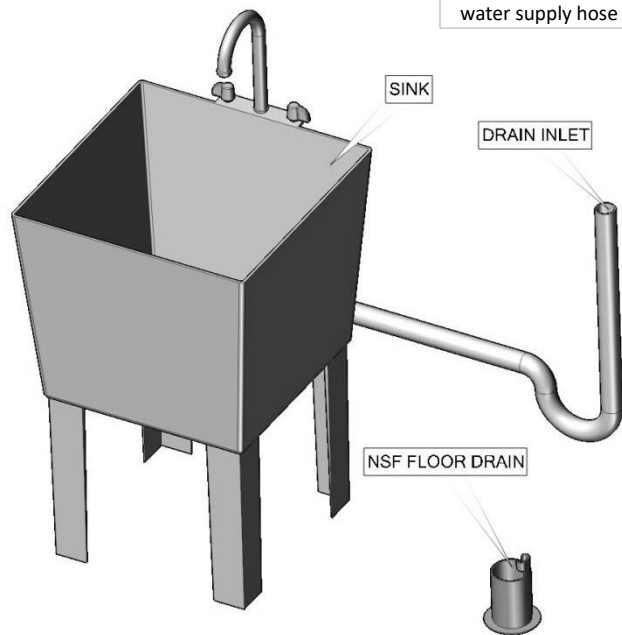

FIG.1

● DRAIN SOURCE:

There are three approved methods for waste discharge that flows from the "25' BYPASS SYSTEM DRAIN HOSE", which extends from the "BYPASS SYSTEM".

Unlike discharging waste through the "FREEZER DOOR" as in manual operations, the automated sequence of the Hydra Rinse® Process manages waste by removing it up through the food product mix inlet hole(s), completely opposite of traditional methods.

The uses of a Sink, Drain Inlet, or an NSF approved floor drain e.g., 1- 1/2" above drain gate, are all valid options for the waste discharge.

 (Image for illustration only) **FIG.2**

Section 10: HRWAND128 Portable Wandstation

● GENERAL INFORMATION:

Refer to your operator's manual supplied with the HRWAND128 product for installation process and mounting information.

The "MOUNTING BRACKET" performs three simple features:

1. It provides a sturdy nesting place for the HRWAND128.
2. It's designed to be NSF compliant, meaning that it requires no tools for easy cleaning and removal for going mobile.
3. The lower hanging feature allows for easy stowing of the "POLYURETHANE 3/8" O.D. WATER SUPPLY HOSE"

As you will see the HRWAND128 is an important device used in the Hydra Rinse® cleaning process. It can be used on all hard-non-porous food contact related surfaces of all soft serve equipment during the Hydra Rinse® Process. The Wandstation eliminates the need for manual mixing of cleaner/sanitizer solution.

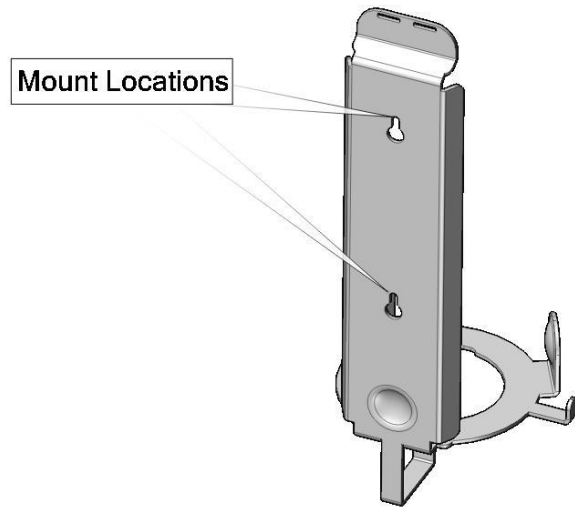

FIG.C

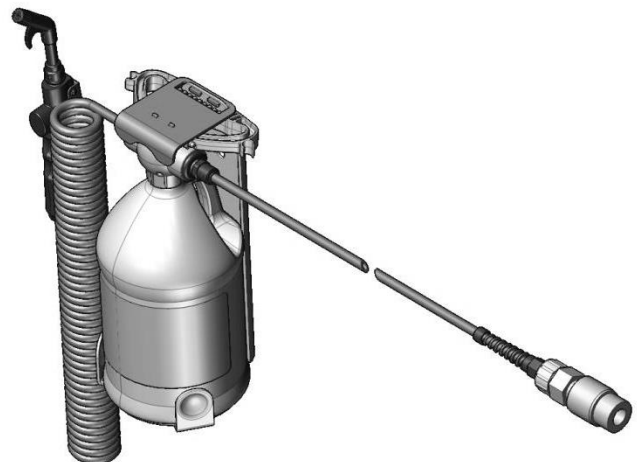

FIG.D

Section 11: Upgraded Components

● UPGRADE COMPONENTS:

Be sure to upgrade every soft serve machine that is intended for cleaning with the Hydra Rinse® System (www.hydrarinse.com). Hydra Rinse® upgrade components are specific for every STLHR variant.

Installation of these upgrade components allows the Hydra Rinse® System to perform efficiently.

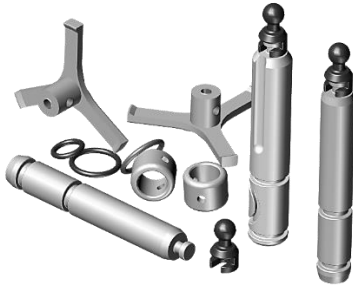

Note: Food safe lube will no longer be applied to Front Auger Bushings

● REAR SEAL ASSEMBLY SUPPORT:

Included with your HR Upgrade KIT is a "Rear Seal Assembly Support" (O-ring). Its function is to keep the "OEM Rear Seal Assembly" perpendicular to the "Auger Shaft" during re-installation.

When re-installing the auger assembly back into the freezing cylinder, the "OEM Rear Seal Assembly" has a tendency to tilt **FIG.5**, causing the potential for a compromised seal against the freezing cylinder's rear wall; there is no need to apply any food safe lubrication to the "Rear Seal Assembly Support", the O-ring is self-lubricated.



WARNING: Failure to apply the "Rear Seal Assembly Support" can allow Hydra Rinse® solution/ product mix to enter the inner workings of the soft serve machine.

Installation without the "Rear Seal Assembly Support" **FIG.5**

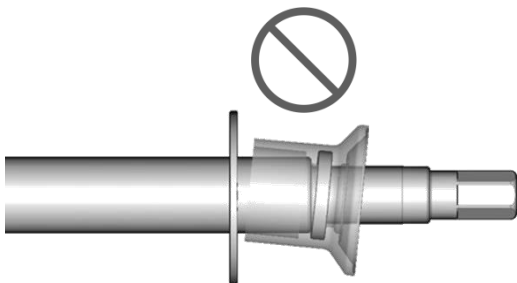

Installation with the "Rear Seal Assembly Support" **FIG.6**

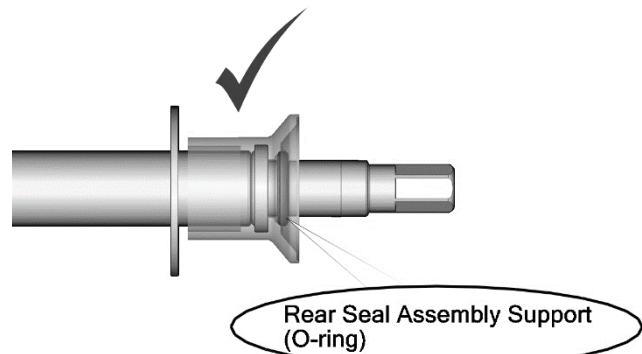

Section 12: NSF Certified Hydra Rinse® Process

✪ **Upgrading soft serve machine (Section 11: Upgraded Components) prior to performing the Hydra Rinse™ Process is required** ✪

- Step 1:** Review Section 14: "Details of the Hydra Rinse® Process" before referencing this document.
- Step 2:** Place machine in "Sleep Mode". Wait approximately 4 to 5 hours for product to reach temperature >30°F (-1.1°C).
- Step 3:** Remove Hopper Cover(s) and clean/sanitize using wand solution, wipes and/or towels (place on sanitized surface).
- Step 4:** Remove Mix Inlet Regulator/Assembly(s) from the hopper(s) and place into a sanitized catch bin or sink.
- Step 5:** Drain product from the soft serve machine into a sanitized bucket if intended for rerun (immediately refrigerate).
- Step 6:** Turn main power off and fill freezing cylinder(s) with solution using wand while cleaning hopper(s). Dispense solution for roughly one minute per hopper. Ensure machine power is on and place each freezing cylinder(s) in "Clean Mode". Allow the solution to reach the top of the mix inlet hole(s). If needed, dispense out enough solution to keep levels just below the mix inlet hole(s) i.e., roughly 2/3 full.
- Step 7:** Continue cleaning all hopper(s) surfaces using wand, wipes and/or towels with OEM brushes. Ensure to brush the mix inlet hole(s) and low mix sensor(s); imperative that the machine is taken out of "Clean Mode" and powered down before using barrel brushes on mix inlet hole(s). After brushing, power up machine and place each freezing cylinder back into "Clean Mode".
- Step 8:** Wait 2 minutes. Drain gray water from the freezing cylinder(s) into a catch bucket. Power down machine.
- Step 9:** Remove Cap-Rosette/Extension(s), Spigot(s); place a catch bucket under the front door and flush Spigot Port(s) with wand.
- Step 10:** With a catch bucket under front door, continue cleaning all exposed bottom surfaces using wand, wipes and/or towels along with OEM brushes.
- Step 11:** Apply one last application of wand solution to the hopper(s) (option to momentarily place machine in "Clean Mode" to remove any remaining residual). Give the top of the soft serve machine one last wipe down.
- Step 12:** Wet Bypass Tube/Adaptor(s) with wand solution to lubricate and sanitize.
- Step 13:** Install Bypass Tube/Adaptor(s) into mix inlet hole(s) and replace hopper cover(s).
- Step 14:** Place and secure Bypass Drain Hose to one of the three acceptable drain sources.
- Step 15:** Wet piston O-rings on the Pro-control Module with either the wand solution and/or wipes to lubricate.
- Step 16:** Install the Pro-control Module onto the front door. Engage Keeper Switch to secure in place.
- Step 17:** Connect main water supply by wetting the quick connect on either the Pro-control Module or on the water supply hose with wand solution and/or wipes.
- Step 18:** Remove cup housings from the Pro-control, and insert either 1 new LEXX™ Cup, or 2 fluid ounces of LEXX™ into each Cup Housing. Re-attach the cup housings to the Pro-control Module.
- Step 19:** Review readiness check list. Press and then release the "ONE TOUCH" button to initialize cycle.
- Step 20:** Roughly 35 seconds and/or first sequential audible beeps from the Pro-control Module: Turn main power on and place soft serve machine in "Clean Mode" for each freezing cylinder.
- Step 21:** Manually scrub clean and sanitize any components removed during Step 4 and 9, or simply begin prepping the next soft serve machine that is going to be cleaned with the Hydra Rinse® System.
- Step 22:** Pause the Pro-control Module cycle when prompted (sequential audible beeps with all three LEDs flashing). Take the soft serve machine out of "Clean Mode" for each freezing cylinder, power off the soft serve machine. Disconnect the water supply hose, drain machine (Section 14 page 22) and then remove the Pro-control Module from the front door. Remove front door and internal components of the soft serve machine for mechanical scrubbing; clean, and then sanitize all components including all front door and freezing cylinder surfaces. Re-assemble soft serve machine, and then re-install the front door. Re-connect the Pro-control Module and the water supply hose. Power up the soft serve machine. Press and then release the "PLAY/PAUSE" button on the Pro-control Module to resume the cycle. Power up machine and place back into "Clean Mode" for each freezing cylinder.
- Step 23:** When the "GREEN LED" is steadily blinking, the cycle is complete. Take freezing cylinder(s) out of "Clean Mode" and power down. Place sanitized catch bucket under the Pro-control Module, pull a Bypass Tube/Plug from the mix inlet hole. Remove Left Cup Housing to drain sanitizing solution from machine (option to momentarily place machine back in "Clean Mode" to remove any residual sanitizing solution from freezing cylinder(s)). Re-attach Left Cup Housing after draining is completed.
- Step 24:** Disengage the Keeper Switch and remove the Pro-control Module and the Bypass System from soft serve machine.
- Step 25:** Wipe down soft serve machine outer shell with wipes and/or towelings. Replace Hopper Cover(s). Check and clean all Drip Trays/Pans.
- Step 26:** Reconnect main water supply hose to the Pro-control Module, and run "Self-clean Mode" while cleaning with wipes and/or towels (Enter self-clean mode by holding down both the "ONE TOUCH" and the "PLAY/PAUSE" buttons simultaneously for 5 seconds).
- Step 27:** Sanitize Bypass Tube/Adaptor(s), OEM barrel brushes and anything else used during this process with wand solution before stowing.
- Step 28:** Add Product Mix; Ready machine for "Serve Mode". If product mix is not being added back into the soft serve machine within 72 hrs. following this process: Remove the freezer door and all internal components for air drying.

Remember to perform a Pro-control Module self-cleaning cycle after every use.

Section 13: NSF Certified Flavor Change Process

✪ **Upgrading soft serve machine (Section 11: Upgraded Components) prior to performing the Hydra Rinse™ Process is required** ✪

- Step 1:** Review Section 14: "Details of the Hydra Rinse® Process" before referencing this document.
- Step 2:** Place machine in "Sleep Mode". Wait approximately 4 to 5 hours for product to reach temperature >30°F (-1.1°C).
- Step 3:** Remove Hopper Cover(s) and clean/sanitize using wand solution, wipes and/or towels (place on sanitized surface).
- Step 4:** Remove Mix Inlet Regulator/Assembly(s) from the hopper(s) and place into a sanitized catch bin or sink.
- Step 5:** Drain product from the soft serve machine into a sanitized bucket if intended for rerun (immediately refrigerate).
- Step 6:** Turn main power off and fill freezing cylinder(s) with solution using wand while cleaning hopper(s). Dispense solution for roughly one minute per hopper. Ensure machine power is on and place each freezing cylinder(s) in "Clean Mode". Allow the solution to reach the top of the mix inlet hole(s). If needed, dispense out enough solution to keep levels just below the mix inlet hole(s) i.e., roughly 2/3 full.
- Step 7:** Continue cleaning all hopper(s) surfaces using wand, wipes and/or towels with OEM brushes. Ensure to brush the mix inlet hole(s) and low mix sensor(s); imperative that the machine is taken out of "Clean Mode" and powered down before using barrel brushes on mix inlet hole(s). After brushing, power up machine and place each freezing cylinder back into "Clean Mode".
- Step 8:** Wait 2 minutes. Drain gray water from the freezing cylinder(s) into a catch bucket. Power down machine.
- Step 9:** Remove Cap-Rosette/Extension(s), Spigot(s); place a catch bucket under the front door and flush Spigot Port(s) with wand.
- Step 10:** With a catch bucket under front door, continue cleaning all exposed bottom surfaces using wand, wipes and/or towels along with OEM brushes.
- Step 11:** Apply one last application of wand solution to the hopper(s) (option to momentarily place machine in "Clean Mode" to remove any remaining residual). Give the top of the soft serve machine one last wipe down.
- Step 12:** Wet Bypass Tube/Adaptor(s) with wand solution to lubricate and sanitize.
- Step 13:** Install Bypass Tube/Adaptor(s) into mix inlet hole(s) and replace hopper cover(s).
- Step 14:** Place and secure Bypass Drain Hose to one of the three acceptable drain sources.
- Step 15:** Wet piston O-rings on the Pro-control Module with either the wand solution and/or wipes to lubricate.
- Step 16:** Install the Pro-control Module onto the front door. Engage Keeper Switch to secure in place.
- Step 17:** Wet the Quick Connect on either the Pro-control Module or on the water supply hose with wand solution and/or wipes.
- Step 18:** Remove cup housings from the Pro-control, and insert either 1 new LEXX™ Cup, or 2 fluid ounces of LEXX™ into each Cup Housing. Re-attach the cup housings to the Pro-control Module.
- Step 19:** Review readiness check list. Press and then release the "ONE TOUCH" button to initialize cycle.
- Step 20:** Roughly 35 seconds and/or first sequential audible beeps from the Pro-control Module: Turn main power on and place soft serve machine in "Clean Mode" for each freezing cylinder.
- Step 21:** Manually scrub clean and sanitize any components removed during Step 4 and 9, or simply begin prepping the next soft serve machine that is going to be cleaned with the Hydra Rinse® System (roughly 7 minutes of free time).
- Step 22:** When the "GREEN LED" is steadily blinking, the cycle is complete. Take freezing cylinder(s) out of "Clean Mode", power down machine. Place sanitized catch bucket under the Pro-control Module, pull a Bypass Tube/Plug from the mix inlet hole. Remove the left cup housing to drain sanitizing solution from machine (option to momentarily place machine back in "Clean Mode" to remove any residual sanitizing solution from the freezing cylinder(s)). Re-attach left cup housing after draining is completed.
- Step 23:** Disengage the Keeper Switch and remove the Pro-control Module and the Bypass System from soft serve machine.
- Step 24:** Use wand solution, OEM barrel brushes, wipes and/or towels to mechanically scrub Spigot Port(s) and O-rings.
- Step 25:** Reinstall Spigot(s) and O-rings respectively.
- Step 26:** Wipe down soft serve machine outer shell with wipes and/or toweling. Replace hopper cover(s). Check and clean all Drip Trays/Pans.
- Step 27:** Reconnect main water supply hose to the Pro-control Module, and run "Self-clean Mode" while cleaning with wipes and/or towels (Enter self-clean mode by holding down both the "ONE TOUCH" and the "PLAY/PAUSE" buttons simultaneously for 5 seconds).
- Step 28:** Sanitize Bypass Tube/Adaptor(s), OEM barrel brushes and anything else used during this process with wand solution before stowing.
- Step 29:** Add Product Mix; place machine in "Serve Mode". If product mix is not being added back into the soft serve machine within 72 hrs. following this process: Remove the freezer door and all internal components for air drying.

Remember to perform a Pro-control Module self-cleaning cycle after every use.

Section 14: Details of the Hydra Rinse® Process

○ REMOVE PRODUCT FROM MACHINE:

Place soft serve machine in "SLEEP MODE" for a minimum of 4 hours; ensure cleaning utensils are sanitized before use e.g., buckets, brushes, etc.

It doesn't matter if the gravity soft serve machine is a single hopper, or a double hopper: You must remove the "MIX INLET REGULATOR/ASSEMBLY" and fully drain the entire machine (~2/3 when removing frozen product); never attempt to perform the Hydra Rinse® Process with frozen or thawed product mix present in the "FREEZING CYLINDER(S)"; clean and sanitize "HOPPER COVER(S)" and place on a sanitized surface.

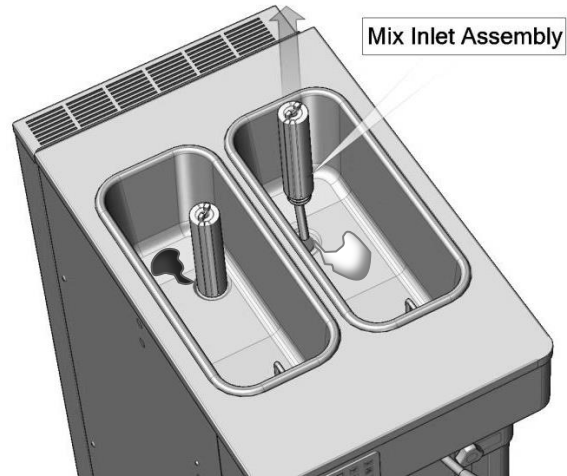

Turn off "FREEZING CYLINDER(S)"

(Image for illustration only) **FIG.7**

○ CLEAN HOPPER(S) AND FREEZING CYLINDER(S):

Power down the machine and begin chasing all product mix residual from the "HOPPER(S)" down into the "FREEZING CYLINDER(S)" using the "HRWAND128".

While dispensing solution, use the "HYDRA RINSE® WIPES" to assist with the process. After approximately 1 minute of dispensing, power the machine back on and place the soft serve machine into "CLEAN MODE"; continue cleaning and dispensing solution into the "HOPPER(S)"; if the hopper(s) begins to fill with solution above the mix inlet hole(s), drain only enough solution to remove the overflow by drawing the corresponding "SPIGOT"; drain waste into a catch bucket. Allow "CLEAN MODE" to continue to agitate solution for roughly 2 minutes.

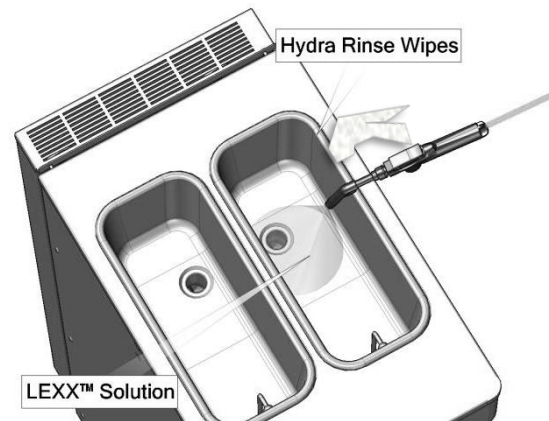

(Image for illustration only) **FIG.8**

Section 14: Details of the Hydra Rinse® Process

○ DRAIN HOPPER(S) AND FREEZING CYLINDERS):

If you haven't yet, remove everything that needs to be manually cleaned from the "HOPPER(S) i.e., Mix Inlet Regulator/Assembly(s), and let soak in sanitizer/cleaner solution.

Next, take the freezing cylinder(s) out of "CLEAN MODE" and power down the machine; drain the solution. Remove "CAP-ROSETTE/EXTENSION(S) and "SPIGOT(S)" from the front door if applicable.

Allow the sanitizer/cleaner solution to continue to drain from the machine. Again, take the "HRWAND128" and dispense into the "HOPPER(S)" to give everything one last dose of fresh sanitizer/cleaner solution.

Note: Option to power machine up and place back in "CLEAN MODE" to help clear the "FREEZING CYLINDER(S)" of any remaining residual solution; immediately take the machine out of "CLEAN MODE" and turn power "OFF" once completed. Wipe surrounding surfaces down with "HYDRA RINSE® WIPES".

○ REMOVABLE SPIGOTS(S):

Remove excess product mix off all front door soiled surfaces. Carefully inspect the lower "FRONT DOOR" for mix residual, and diligently scrub around the "CAP-ROSETTE/EXTENSION(S)" front door mounting features.

Wipe surfaces clean using "HYDRA RINSE® WIPES".

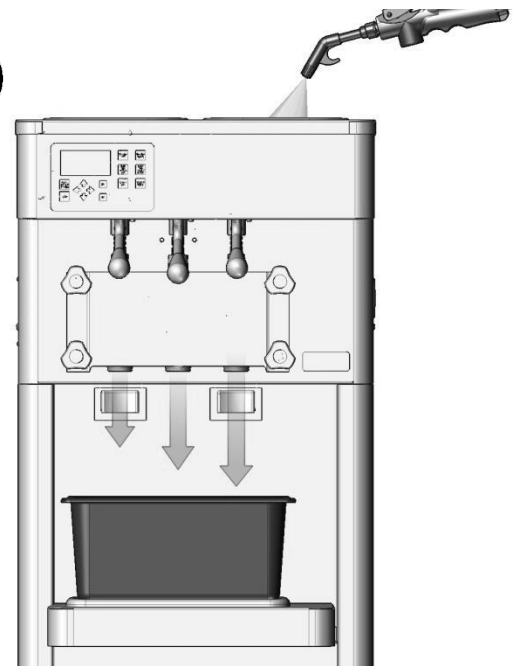

While machine is powered down, take a sanitized barrel brush to mechanically scrub the mix inlet port(s) and low mix sensor in the hopper(s).

(Image for illustration only) **FIG.9**

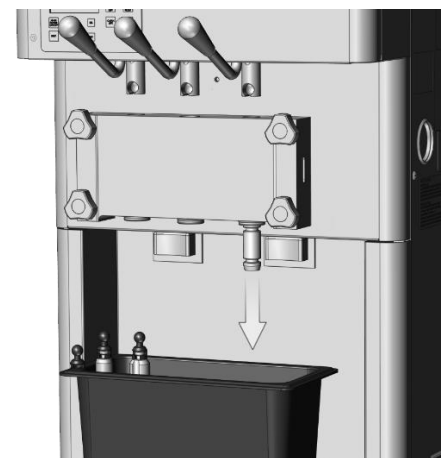

(Image for illustration only) **FIG.10**

Section 14: Details of the Hydra Rinse® Process

○ INSTALLING BYPASS SYSTEM:

Each STLHR variant comes with the respective "BYPASS SYSTEM" for properly connecting to the "25' BYPASS SYSTEM DRAIN HOSE".

Before inserting the "BYPASS TUBE/ADAPTOR" into the product mix inlet hole(s), wet the O-rings on the "BYPASS TUBE/ADAPTOR" with either a "HYDRA RINSE® WIPE", or with the sanitizer/cleaner solution from the "HRWAND128". For added ease of installation, gently wiggle the "BYPASS TUBE/ADAPTOR" back and forth while pressing downward; ensure "HOPPER COVER(S)" have been cleaned and replaced over the top of the "BYPASS SYSTEM" **FIG.11** to protect "HOPPER(S)" from recontamination i.e., airborne mold.

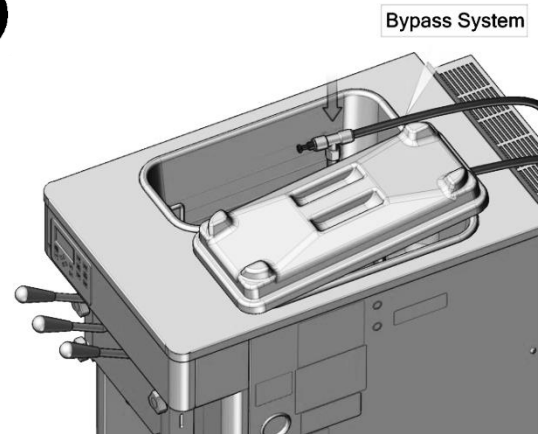

(Image for illustration only) **FIG.11**

Note: Never apply food safe lube to the "BYPASS TUBE/ADAPTOR(S)". If lube is already present on the mix inlet hole(s), it must be completely removed before inserting "BYPASS TUBE/ADAPTOR(S)".

○ BYPASS SYSTEM LIMITATIONS:

The automated portion of the Hydra Rinse® Process will **not work** effectively if the "BYPASS SYSTEM" is installed more than 12 inches above the machine as illustrated **FIG.12**.

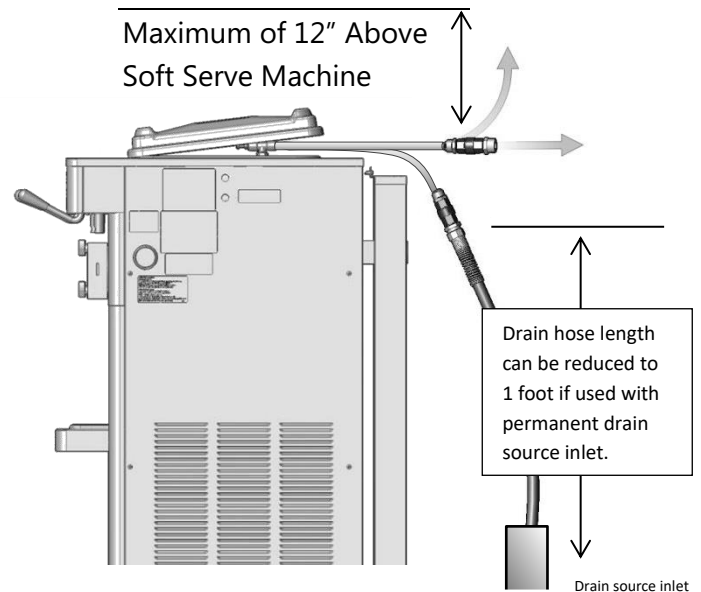

(Image for illustration only) **FIG.12**



WARNING

MAKE **NO MODIFICATIONS** TO THE "BYPASS SYSTEM" with one exception:

- 25' Bypass System Drain Hose can be reduced to a minimum of 1 foot as illustrated.

CAUTION: Ensure the Bypass System Drain Hose is never kinked or obstructed from flowing during operation.

Section 14: Details of the Hydra Rinse® Process

○ SECURING BYPASS DRAIN HOSE:

Whichever option you choose for your drain source (page 10), ensure that the "25' BYPASS SYSTEM DRAIN HOSE" is not only properly secured, but also properly positioned about the drain to ensure compliance with State and local health codes, which addresses backflow prevention.

Note: The Hydra Rinse® "BYPASS SYSTEM" is equipped with a check valve.

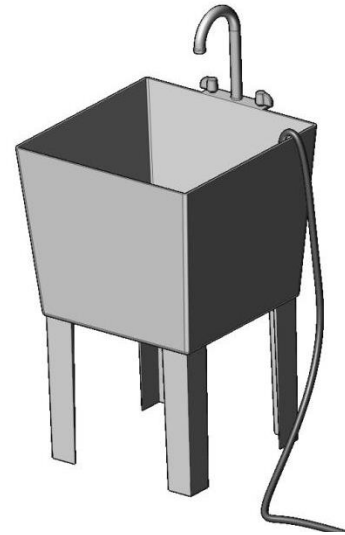

(Image for illustration only) **FIG.13**

○ SECURING THE PRO-CONTROL MODULE:

To assist with installing the "PRO-CONTROL MODULE", wet the O-rings on the pistons with either a "HYDRA RINSE® WIPE" or with sanitizer/cleaner solution from the "HRWAND128".

Simply use the "CENTER PISTON" to guide the unit up into the "CENTER SPIGOT PORT" **FIG.14**; once the piston O-rings begin to contact the "SPIGOT PORT(S)", gently wiggle the unit while pushing upward on the ends of the underside of the "INTERFACE MANIFOLD ASSEMBLY".

Located on the top of the "CENTER PISTON" is a "KEEPER SWITCH". The "PRO-CONTROL MODULE" is in position when the "KEEPER SWITCH" can slide forward, securing the unit into place **FIG.14A**.

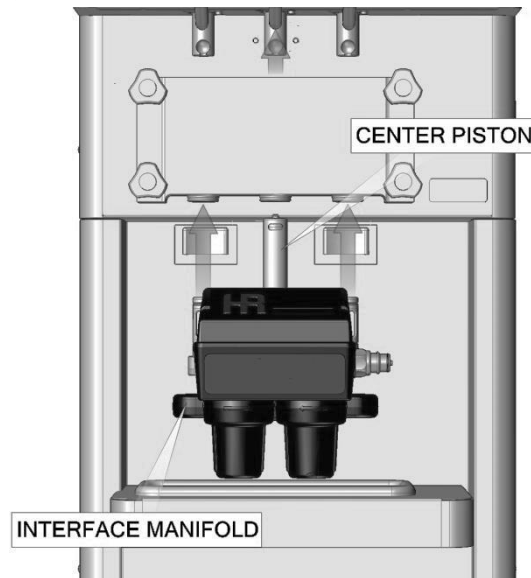

(Image for illustration only) **FIG.14**



illustration **FIG.14A**

Section 14: Details of the Hydra Rinse® Process

○ CONNECT WATER SUPPLY:

Prior to connecting the "WATER SUPPLY", wet the O-ring on the "PRO-CONTROL MODULE QUICK CONNECT" **FIG.15** with either a "HYDRA RINSE® WIPE" or with the sanitizer/cleaner solution from the "HRWAND128"; once connected, if the water source has not been turned on yet, you will need to do so before adding the LEXX™ concentrate.

Note: Always ensure cup housings are present and that you haven't added new LEXX™ concentrate until the water source is connected and turned on.

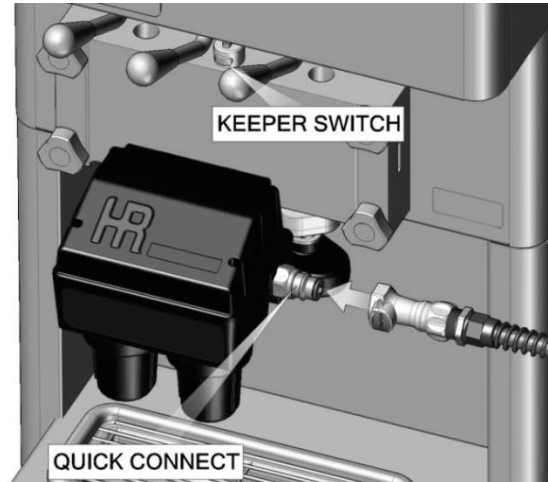

○ ADDING LEXX™ CONCENTRATE:

To remove the left "CLEANER CUP HOUSING", rotate outward from the center of the Pro-control Module for less than a quarter turn. To remove the right "SANITIZER CUP HOUSING", once again rotate outward from the center of the Pro-control Module for less than a quarter turn.

Put 1 ready to use "LEXX™ CUP" or 2 fluid ounces of LEXX™ concentrate into each of the cup housings.

While pushing the nested "LEXX™ CUP" up into the piercing features of the "PRO-CONTROL MODULE", align the mating features of the "CUP HOUSING" to the main body; pay close attention that the cup lid has been adequately pierced.

Practice working with the "CUP HOUSINGS" prior to adding actual cups.



(Image for illustration only) **FIG.15**

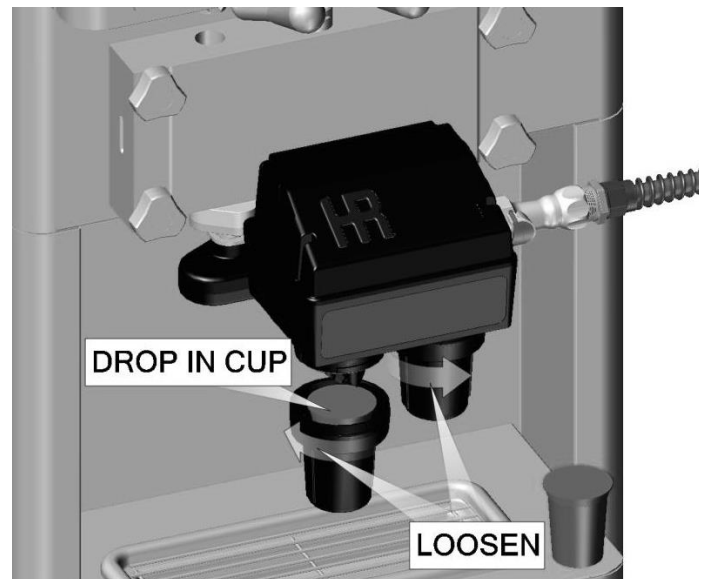

(Image for illustration only) **FIG.16**

Note: Lube the cup housing face seal **FIG.16A** with food safe lube when "ALIGNMENT ARROWS" become difficult to align

Lube sealing face, not O-ring (Bottom View)

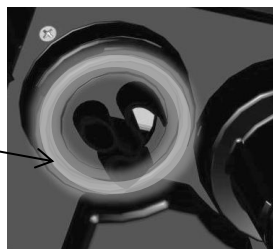

FIG.16A

Section 14: Details of the Hydra Rinse® Process

● TIGHTEN CUP HOUSINGS:

It's important that sanitizer/cleaner solution is present during every cycle, so too is proper tightening of both the "CLEANER CUP HOUSING" and the "SANITIZER CUP HOUSING".

To tighten the cup housings, rotate inward towards the center of the "PRO-CONTROL MODULE". As called out in **FIG.17**, there are corresponding "ALIGNMENT ARROWS" molded into the plastic components; for proper seal, ensure they are aligned together as illustrated. (Storage page 27, **FIG.32**).

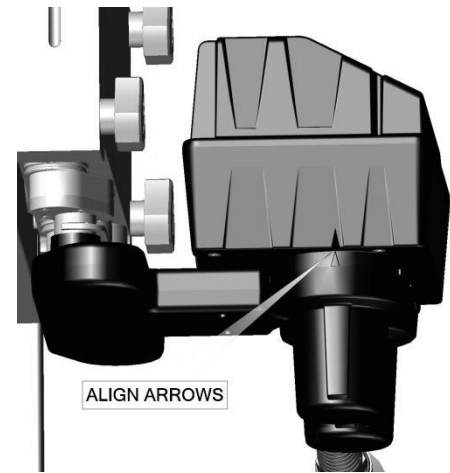

(Image for illustration only) **FIG.17**

● START THE PRO-CONTROL MODULE CYCLE:

Run through this suggested check list before continuing:

- Bypass System in place, Hopper Cover(s) present.
- Bypass System Drain Hose attached and secured to 1 of the 3 acceptable drain sources (page 18).
- Specified sanitary water source (page 1) connected and turned on.
- Fresh LEXX™ concentrate present in both the cleaning and sanitizing cup housings.
- Soft Serve Machine Power is "ON"

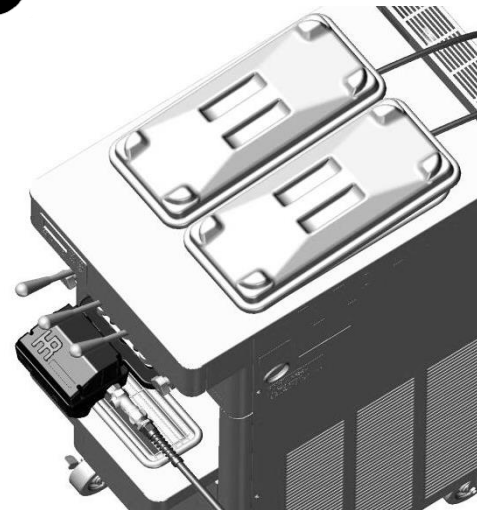

(Image for illustration only) **FIG.18**

Section 14: Details of the Hydra Rinse® Process

Next, press and then release the “ONE TOUCH” button on the “USER INTERFACE” to start the “PRO-CONTROL MODULE CYCLE”. Wait 35 seconds and/or first beep sequence of the “PRO-CONTROL MODULE CYCLE”, and then power up the soft serve machine and place each freezing cylinder in “CLEAN MODE”.

If for any reason there arises a need to quickly cancel the “PRO-CONTROL MODULE CYCLE”, press and then release the “PLAY/PAUSE” button within 15 seconds of pressing “ONE TOUCH”; the cycle will be canceled.

If it’s been longer than 15 seconds since pressing the “ONE TOUCH” button, the cycle cannot be canceled, only paused and the total available wash cycles will receive a “DING” i.e., 100-1 = 99 remaining wash cycles.

Note: Pressing and releasing the “PLAY/PAUSE” button after the 15 second cancelation window has lapsed will only suspend the “PRO-CONTROL MODULE CYCLE” indefinitely until the “PLAY/PAUSE” button is pressed and released again to resume it; this allows end users to make necessary adjustments when required.

● ANCILLARY COMPONENTS:

While the “PRO-CONTROL MODULE CYCLE” is running for approximately 7 minutes, all previously removed components can be broken down for cleaning and sanitizing; use the “HRWAND128” in place of filling a three-bay sink.

After components are deemed soil free, apply one last application of sanitizer/cleaner solution; **no rinsing** required prior to reassembly.

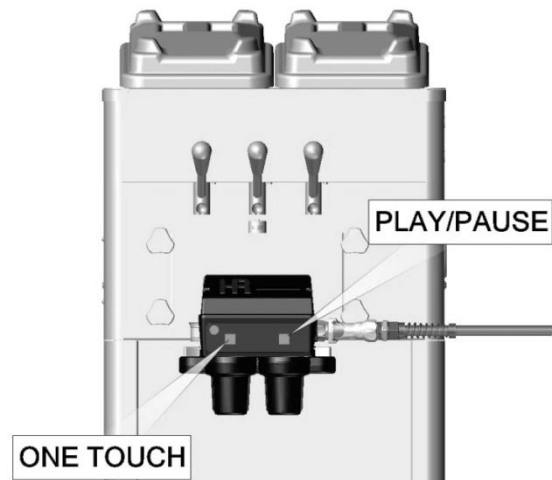

(Image for illustration only) **FIG.19**

Warning: If you press and then release the “RESET-CUPS-PROGRAM” button after the cycle has commenced, or any time before it has completed, your cycle will be aborted causing the “PRO-CONTROL MODULE” to reboot. You will be “DINGED” losing 1 cycle as if that cycle had completed successfully, so be mindful.



(Image for illustration only) **FIG.20**

Section 14: Details of the Hydra Rinse® Process

○ PRO-CONTROL MODULE CYCLE COMPLETE:

With a steady blinking Green LED on the "USER INTERFACE": take the freezing cylinder(s) out of "CLEAN MODE" and power down the soft serve machine; press and then release the "PLAY/PAUSE" button to conclude cycle, placing the Pro-control Module unit back into sleep mode. Drain solution and remove the "PRO-CONTROL MODULE".

With a catch bucket below the unit, remove the "CLEANER CUP HOUSING"; left side **FIG.21** to begin draining.

To relieve the vacuum lock for proper draining, either remove the entire "BYPASS TUBE/ADAPTOR" (optional prybar available **FIG.21A**) from the product mix inlet hole, or simply remove the "PUSH-TO-CONNECT PLUG" from the "BYPASS TUBE" itself; you'll find that removing the bypass push-to-connect plug is more convenient.

Disconnect the "WATER SUPPLY" from the "PRO-CONTROL MODULE". Replace the cup housing, and then slide the "KEEPER SWITCH" backwards into the neutral position; remove unit from the soft serve machine.

To simplify the removal of the "PRO-CONTROL MODULE": Simply wiggle the unit back and forth while pressing downward on the ends of the "PRO-CONTROL MODULE MANIFOLD", not the Pro-control Module itself **FIG.22**.

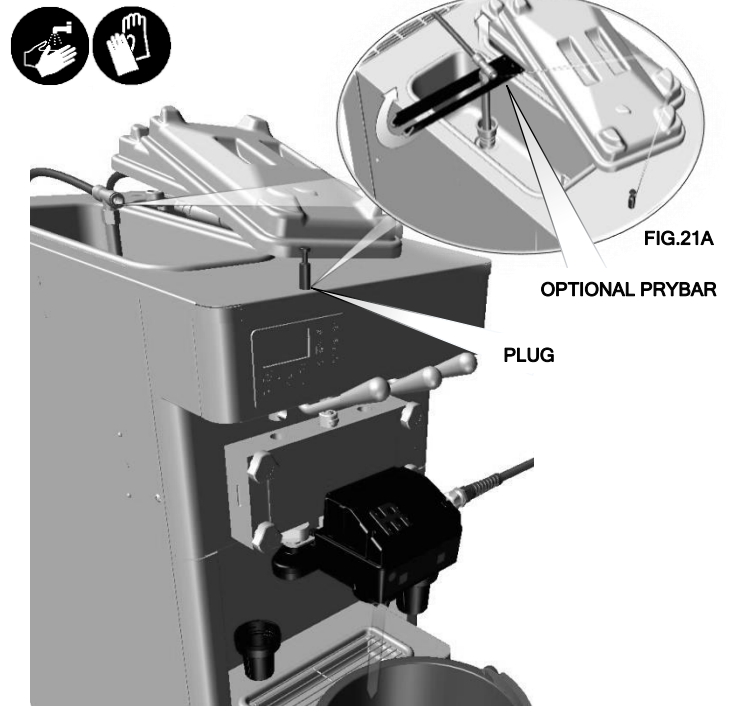

(Image for illustration only) **FIG.21**

Tip: Option to momentarily power up the soft serve machine and place the freezing cylinder(s) in "CLEAN MODE", which helps remove any remaining solution from the freezing cylinder(s).

Note: Remember to periodically test Drained LEXX™ (**Appendix B**).

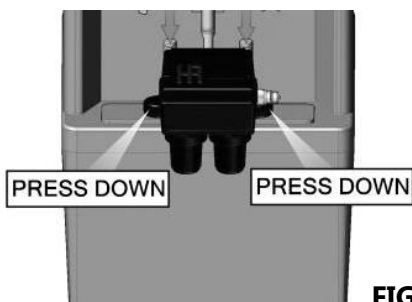

FIG.22

Section 14: Details of the Hydra Rinse® Process

○ MACHINE RE-ASSEMBLY:

Take care when re-assembling the soft serve machine to ensure that you are not re-introducing any contaminants while handling the components; this is a good time to refresh your gloves! Prior to re-assembly of the front door, use an OEM barrel brush and give the spigot port(s) a good mechanical scrubbing. Adequately flush all mechanically scrubbed surfaces with the Wand and then precede to re-assembly the front door.

This concludes the cleaning and sanitizing of the soft serve machine without mechanical scrubbing of the internal components.

Tip: Use the “HRWAND128” to keep things wet during re-assembly! This will ensure sanitization while handling components, which also provides lubrication for the Lubeless O-rings during re-insertion!

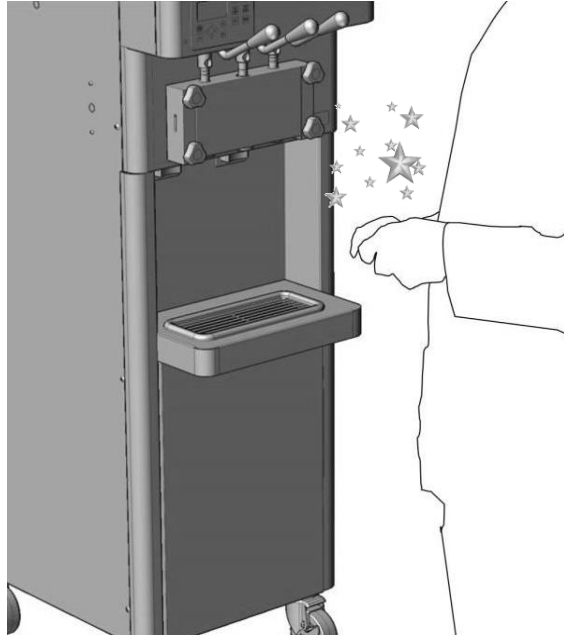

(Image for illustration only) **FIG.23**

○ MACHINE TEARDOWN FOR MECHANICAL SCRUBBING OF INTERNAL COMPONENTS:

The “PRO-CONTROL MODULE” has a special function that enables the end user to pause the cleaning and sanitizing cycle for mechanical scrubbing. This function will be described next, “SEQUENCE FOR MECHANICAL SCRUBBING INTERNAL COMPONENTS”.

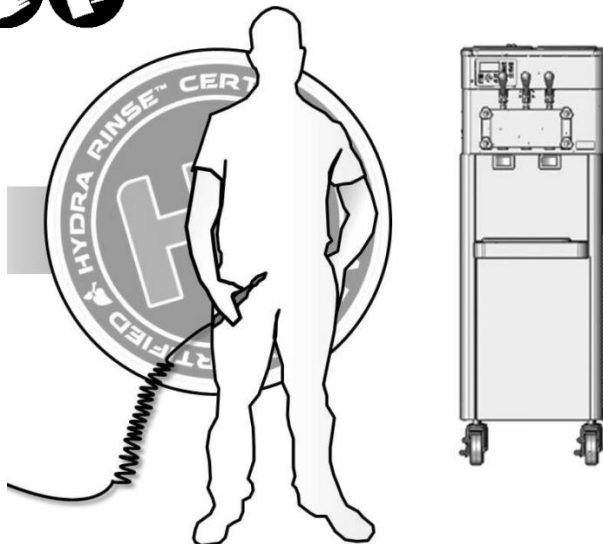

(Image for illustration only) **FIG.24**

Section 14: Details of the Hydra Rinse® Process

↓ SEQUENCE FOR MECHANICAL SCRUBBING INTERNAL COMPONENTS ↓

★ PAUSING THE PRO-CONTROL MODULE:

Roughly 3.5 minutes into the 7-minute cycle, the "PRO-CONTROL MODULE" will sequentially "BEEP" for 15 seconds while all three LEDs "BLINK" simultaneously.

During this sequence press and then release the "PLAY/PAUSE" button to suspend the cycle indefinitely, allowing for machine teardown and mechanical scrubbing.

Once in pause mode, the "GREEN LED" on the "USER INTERFACE" will blink and a "BEEP" will sound once every 30 seconds until the "PLAY/PAUSE" button is once again pressed and then released to resume the cycle.

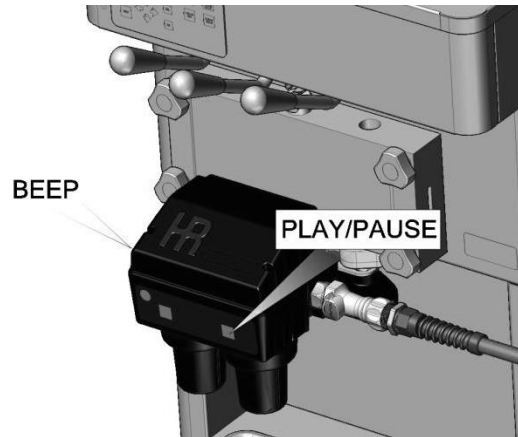

(Image for illustration only) **FIG.25**

Warning: The sanitizer cup solution has not been dispensed yet so do not remove it.

★ SCRUBBING INTERNAL COMPONENTS:

Power down the soft serve machine, "DRAIN SOLUTION", "DISCONNECT WATER SUPPLY" and remove the "PRO-CONTROL MODULE" (page 22).

Once the "FRONT DOOR" is removed from the machine: Use the applicable brushes that were supplied with the OEM soft serve machine for mechanical scrubbing of all components and internal surfaces. Use the "HRWAND128" for dispensing sanitizer/cleaner solution instead of using a 3-bay sink.

Once the components are deemed soil free, apply one last application of sanitizer/cleaner solution; **no rinsing** required.

Re-install "INTERNAL COMPONENTS" and "FRONT DOOR" and all respective "EXTERNAL COMPONENTS".

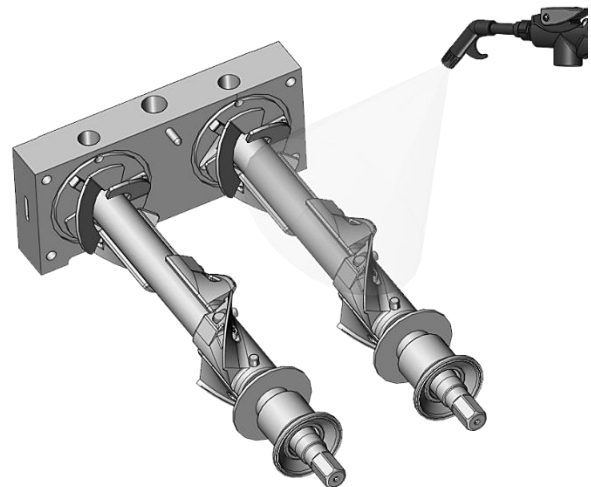

(Image for illustration only) **FIG.26**

Section 14: Details of the Hydra Rinse® Process

★ RE-INSTALL PRO-CONTROL

MODULE:

The "PRO-CONTROL MODULE" is currently in pause mode, so take care not to press any buttons on the "USER INTERFACE" while re-installing.

To assist with installing the "PRO-CONTROL MODULE", wet the O-rings on the pistons with either a "HYDRA RINSE® WIPE" or with sanitizer/cleaner solution.

Simply use the "CENTER PISTON" to guide the unit up into the "CENTER SPIGOT PORT"; once the piston O-rings begin to contact the "SPIGOT PORT(S)", gently wiggle the unit while pushing upward on the ends of the underside of the "INTERFACE MANIFOLD ASSEMBLY".

On the top of the "CENTER PISTON" is the "KEEPER SWITCH". The "PRO-CONTROL MODULE" is in position when the "KEEPER SWITCH" can slide forward, securing the unit into place.

★ RESUME CYCLE:

"RE-ATTACH WATER SUPPLY" and the "BYPASS SYSTEM" if for any reason you needed to remove it. Press and then release the "PLAY/PAUSE" button to resume the cycle **FIG.28**. Power up machine and place each freezing cylinder in "CLEAN MODE".

Note: All three LEDs will blink simultaneously on initial resumption of the cycle for approximately 20-30 seconds; sanitizer injection follows shortly thereafter.

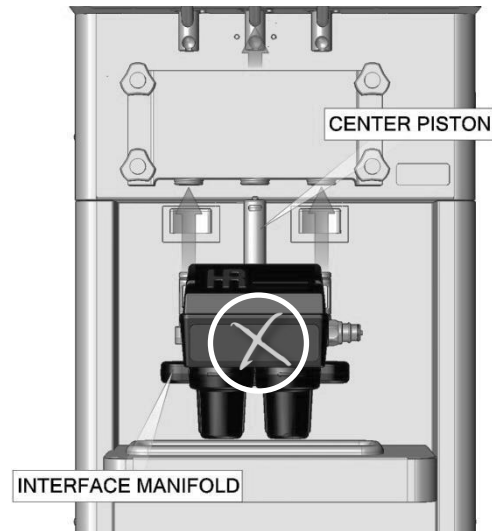

(Image for illustration only) **FIG.27**

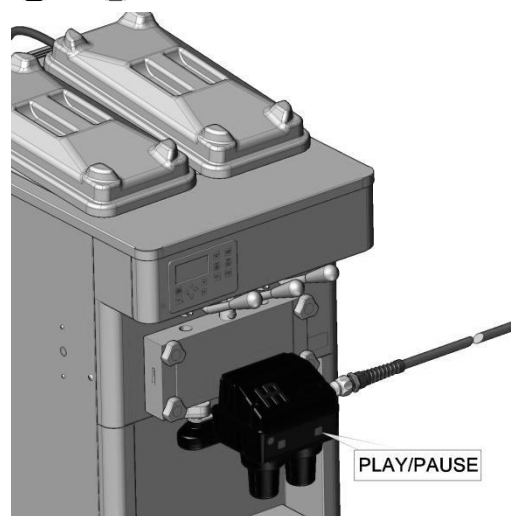

(Image for illustration only) **FIG.28**

↑ SEQUENCE FOR MECHANICAL SCRUBBING CONCLUDED ↑

Section 14: Details of the Hydra Rinse® Process

UTILITY ITEMS:

When cleaning and sanitizing all utility items like waste catch buckets and OEM brushes; remember to integrate the "HRWAND128" and "HYDRA RINSE® WIPES" into all pre-established cleaning protocols for time savings and operator efficiency.

Tip: The "HRWAND128" sanitizer/cleaner solution can also be applied to any non-porous hard food contact surface i.e., floors, food prep areas/counter tops, etc.

Note: OEM barrel brushes work great when addressing the "BYPASS TUBE(S)"; remove "PUSH-TO-CONNECT PLUG(S)" to allow full access for brushing.



(Image for illustration only) **FIG.29**

FINAL STEPS:

"BYPASS TUBE(S)" and the "HYDRA RINSE® PRO-CONTROL MODULE" will always require periodic cleaning and sanitizing.

Remove the "BYPASS SYSTEM" from the soft serve machine. The "BYPASS TUBE(S)" is easily removable from the "BYPASS SYSTEM" for manual scrubbing, cleaning, and sanitizing before stowing.

The "PRO-CONTROL MODULE" has a "SELF-RINSE CYCLE": To initiate, connect "WATER SOURCE" and ensure it's on. Press the "ONE TOUCH" and the "PLAY/PAUSE" buttons simultaneously and hold for ~5 seconds.

All three LEDs (Green, Yellow, and Red) on the "USER INTERFACE" will illuminate indicating that the "SELF-RINSE CYCLE" has commenced; release buttons.

Hold unit over a drain source or catch bucket while flushing is in process.

Tip: Wipe the "PRO-CONTROL MODULE" with "HYDRA RINSE® WIPES" while water is flowing from the unit to clean surfaces.

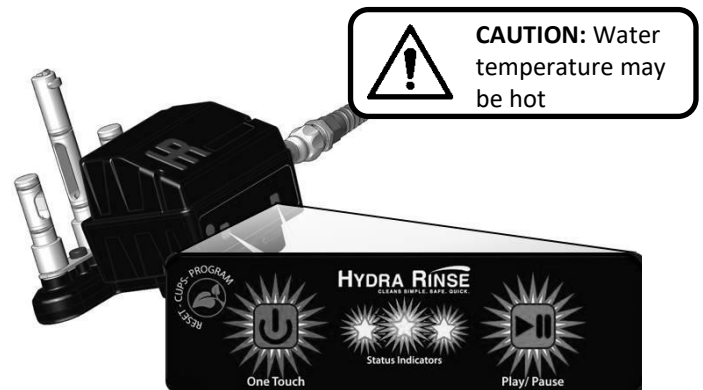

(Image for illustration only) **FIG.30**

Note: If the Green LED on the "USER INTERFACE" is still blinking, which indicates that the "PRO-CONTROL MODULE CYCLE" has completed successfully, the "PLAY/PAUSE" button will need to be pressed and then released prior to entering the "SELF-RINSE CYCLE"; cycle is approximately 30 seconds in duration. (Repeat as many times deemed necessary)

Section 14: Details of the Hydra Rinse® Process

○ CLEANUP AND STORAGE

SUGGESTIONS:

After removal of the "BYPASS SYSTEM" and re-assembly of the soft serve machine i.e., "SPIGOT(S)", "CAP-ROSETTE" and/or "EXTENSION(S)" if applicable: Re-introduce product mix into the machine as soon as possible. If intentions are to leave the machine empty for more than 72 hours, you will be required to power off the soft serve machine, remove the "FRONT DOOR" and disassemble all internal components allowing them to air dry; this is usually the case for end of season storage of the soft serve machine.

Ensure "MIX INLET REGULATOR/ASSEMBLY" is in place prior to putting the "HOPPER COVER(S)" back in position.

Wipe down "FRONT DRIP TRAY" and inspect all "DRAIN TRAY(S)" for cleanliness; give the machine a good wiping down too.

Stow the "25' BYPASS SYSTEM DRAIN HOSE", "WATER SUPPLY HOSE" and the "PRO-CONTROL MODULE" in a clean, dry place having a temperature range no less than 60°F (15.5°C) and no greater than 90°F (32°C).

"TOKEN TAG" registration is a onetime event for every box of "LEXX™ CUPS"; it's not required prior to every "PRO-CONTROL MODULE CYCLE". Keep the "TOKEN TAG", and do not dispose of it. As mentioned earlier, you can use a previously registered "TOKEN TAG" to read out the number of remaining cycles residing in the "PRO-CONTROL MODULE".

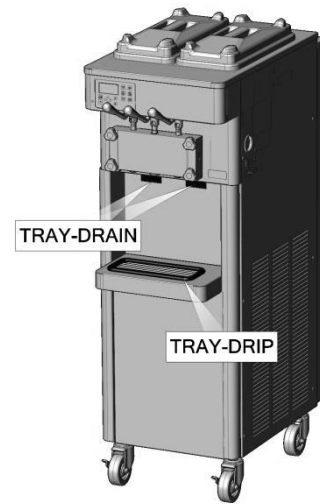

(Image for illustration only) **FIG.31**



Note: Though our devices are engineered to the highest standard, it is recommended at the end of every day that the water source supplied to the "HRWAND128" and the "PRO-CONTROL MODULE" is turned off; connections are not intended for permanent installation. Leaving the devices under constant static pressure could result in unwanted water damage or flooding.

Tip: After every usage, remember to back off the "CUP HOUSINGS" as illustrated **FIG.32**. This will reduce the force required to remove the cups between usages.

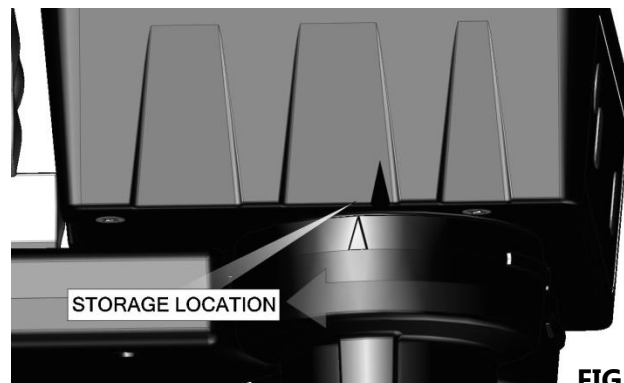
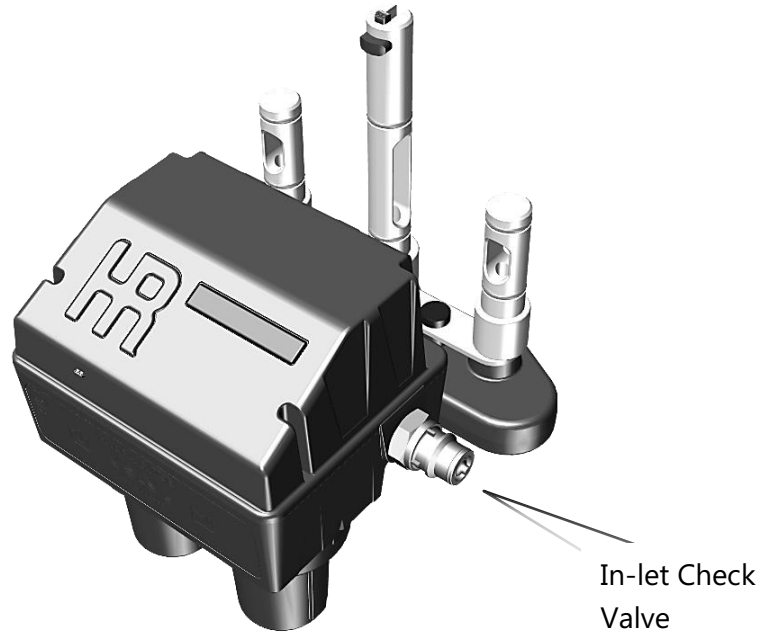

FIG.32

Section 15: Troubleshooting Guide 1 of 2

● Due to the sensitive nature of the “PRO-CONTROL MODULE”; always consult your local authorized Dealer/Reseller when an issue is unresolved.

Refer to the “HRWAND128” Operators Manual for detailed and troubleshooting reference material regarding its practical operation.



Issue:	Potential Cause:	Potential Solution:
Cycle won't start; Red LED blinks fast, Green and Yellow LEDs on.	<ul style="list-style-type: none"> • The unit has no cycles left 	<ul style="list-style-type: none"> • Need to register a new token tag • “RESET-CUP-PROGRAM” button will need to be pressed to exit error
Red LED blinks slow, unit beeps every 15 seconds	<ul style="list-style-type: none"> • Batteries are at end of life 	<ul style="list-style-type: none"> • Install new batteries. • “RESET-CUP-PROGRAM” button will need to be pressed to exit error.
Cycle started, no water flowing, but water is connected and turned on	<ul style="list-style-type: none"> • Extended period of time that the unit has been sitting 	<ul style="list-style-type: none"> • Refer to Appendix B • Contact your local Hydra Rinse® Distributor/Reseller for more information
Unit will not power up	<ul style="list-style-type: none"> • Check that batteries are correctly installed • Corrosion on battery terminals 	<ul style="list-style-type: none"> • Check and/or re-install batteries as required for proper operation • Contact local Distributor/Dealer for replacement
Water lines leak	<ul style="list-style-type: none"> • Improper engagement of push-to-connect to hose • Loosely connected fittings 	<ul style="list-style-type: none"> • Check and push hose into leaking fitting • Tighten leaking fitting an additional, not to exceed 90-110° rotation

TABLE CONTINUED →

Section 15: Troubleshooting Guide 2 of 2

Issue:	Potential Cause:	Potential Solution:
Cup housing(s) are hard to tighten	<ul style="list-style-type: none"> • Worn or no food safe lube present 	<ul style="list-style-type: none"> • Re-lube with food safe lube, replace O-ring(s) if problem unresolved
Cup housing(s) leak	<ul style="list-style-type: none"> • Ensure cups are properly engaged with the Pro-control housing 	<ul style="list-style-type: none"> • Replace O-ring(s)
Bypass Tube won't stay in Mix Inlet Hole	<ul style="list-style-type: none"> • O-ring(s) worn • Food safe lube present • Frozen mix left in Freezer Barrel(s) • Blocked discharge hose 	<ul style="list-style-type: none"> • Replace O-ring(s) • All Lube must be removed • Never perform cycle with frozen mix • Ensure no kinks or blockages in hose
Quick connects leak	<ul style="list-style-type: none"> • Worn out, O-ring damaged 	<ul style="list-style-type: none"> • Contact local Distributor/Dealer for replacement parts/ O-ring

Section 16: Pro-control Module LEDs 1 of 2

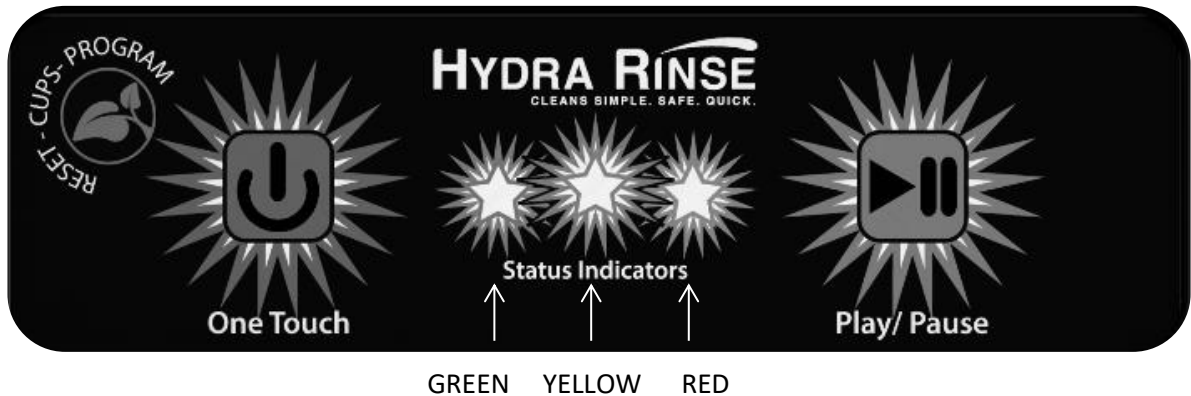

LEDs are the communication portal between end users and the Pro-control Module. Here's a few to understand: (Status Indicators from Left to Right: Green, Yellow, Red)

= LED Blink,
 = LED On,
 = LED Off,
 S = Slow, F = Fast, (1st, 2nd, 3rd) = Order of Blink

PROCESS CODES:					
<u>GREEN</u> Hundreds	<u>YELLOW</u> Tens	<u>RED</u> Ones	<u>BEEP</u>	<u>DESCRIPTION</u>	<u>ACTION</u>
			-	Pro-control Module "Power ON"	-
			-	Pro-control Module "Processing"	-
F			Every 30 seconds Double Beep	Pro-control Module "Pause Mode"	Press "PLAY/PAUSE" to resume cleaning sequence
S			-	Pro-control Module has completed a successful cycle	Press "PLAY/PAUSE" to conclude cycle
1 st	2 nd	3 rd	-	Left to Right LED sequence: Indicates Pro-control Module is in "Cleaning " Mode	-
1 st	2 nd	1 st	10 consecutive beeps	Inward LED sequence: Indicates Pro-control Module is in "Agitate Solution" Mode Inward LED sequence: Indicates Pro-control Module is in "Agitate Solution" Mode	Place Soft Serve Machine in "Wash Mode" reminder

TABLE CONTINUED →

Section 16: Pro-control Module LEDs 2 of 2

= LED Blink,
 = LED On,
 = LED Off,
 S = Slow, F = Fast, (1st, 2nd, 3rd) = Order of Blink

PROCESS CODES CONTINUED:					
<u>GREEN</u> Hundreds	<u>YELLOW</u> Tens	<u>RED</u> Ones	<u>BEEP</u>	<u>DESCRIPTION</u>	<u>ACTION</u>
			15 consecutive beeps	All LEDs Flash simultaneously: 20 seconds to halt cycle for full teardown All LEDs Flash simultaneously: End user pressed "PLAY/PAUSE" button resuming cycle after teardown	Press and then release the "PLAY/PAUSE" button Allow cycle to complete
 3 rd	 2 nd	 1 st	-	Right to Left LED sequence: Indicates Pro-control Module is in "Sanitizing " Mode	-
ERROR CODES:					
		 F	Pulse Beep	No Tokens. End user pressed the "ONE TOUCH" button or registered an empty token tag with zero tokens loaded in unit	Register Token Tag with Pro-control Module (Section 7)
		 F	-	End user pressed the "ONE TOUCH" button, Pro-control Module is not programmed with a cleaning cycle script	CONTACT Dealer/Reseller
		 S	Pulse beeps every 15 sec	End user pressed the "ONE TOUCH" button, Battery is below allowable threshold	Replace Battery (Section 17)
		 F	Pulse beeps every second	Pro-control Module cannot presently accept any more Token Tag cycles, Tokens were not registered (750 Max Limit met)	Save Token Tag for later use. Press and then Release the "RESET-CUPS- PROGRAM" button
For Pro-Control Modules with firmware version pre-3.0:					
			-	No tokens. End User Checked for available token count, and zero tokens loaded in unit	Ensure to register a valid Token Tag. Press and then Release the "RESET-CUPS- PROGRAM" button once for registering and once to reset

Section 17: Battery Installation/Replacement

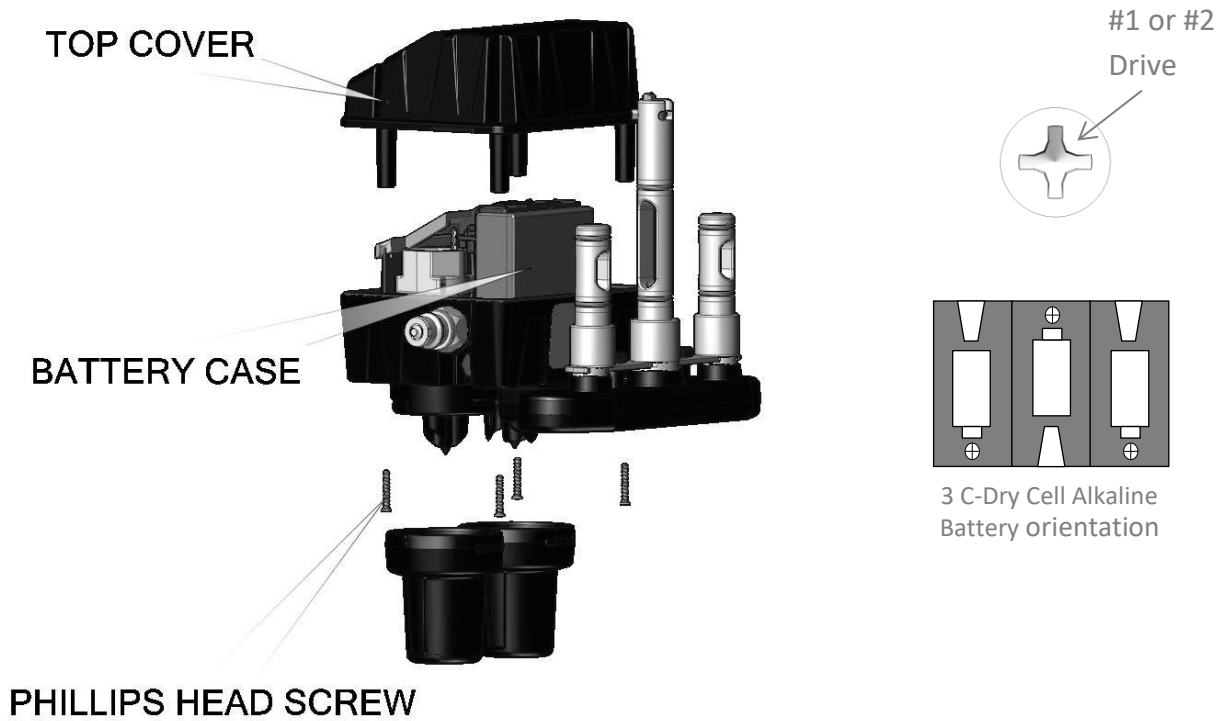

(Image for illustration only) **FIG.33**

To gain access to the "BATTERY CASE":

Note: Before changing the battery(s), remove the Pro-control Module from any areas that may allow water to enter the inner housing compartment.

- Remove both "CUP HOUSINGS" from the "PRO-CONTROL MODULE".
- Remove the 4 "PHILLIPS HEAD SCREWS" that secure the "TOP COVER" to the "PRO-CONTROL HOUSING". (screws located on the underside of unit)
- Slide open the "BATTERY CASE COVER"; ensure batteries are correctly oriented **FIG.33**
- When replacing "PHILLIPS HEAD SCREWS", tighten in a cross pattern while paying close attention to "TOP COVER" gap. When "TOP COVER" meets the "PRO-CONTROL MODULE HOUSING" (no gap), stop tightening screw; over tightening may stress unit causing premature failure.

Section 18: Online Resources/Support

**FOR REPLACEMENT COMPONENTS, ADDITIONAL
INFORMATION, SUPPORT, AND VIDEOS FOR YOUR
HYDRA RINSE® PRODUCTS PLEASE VISIT**

WWW.HYDRARINSE.COM

OR CONTACT YOUR LOCAL HYDRA RINSE® DEALER



Section 19: Warranty

The Seller warrants that the **STLHR** will operate or substantially perform within the published specifications and be free from material and workmanship defects, when subjected to normal, proper, and intended usage by properly trained personnel. Please visit www.hydrarinse.com for warranty registration.

Seller agrees during the Warranty Period, to repair or replace, at Seller's option, defective item(s) to allow the **STLHR** to operate or substantially perform within the published specifications; provided the Buyer (a) promptly notifies the Seller in writing when the defect is discovered, and provides Seller the product model, serial number and details of the warranty claim; and (b) after Seller's review, Seller will provide Buyer with service data and/or a Return Merchandise Authorization ("RMA"), which may include product-specific handling instructions. At that time, the Buyer may return the defective item(s) to Seller with all return shipping costs paid by Seller. The Seller has the option to use new or refurbished replacement parts for warranty work. All replaced parts become the property of Seller. Shipment to Buyer of repaired or replacement parts/equipment will be made in accordance with the Seller's delivery policy.

The Seller has no obligation to make repairs, replacements or corrections, in whole or in part, as the result of: (i) normal wear and tear; (ii) accident, disaster or force majeure; (iii) the Buyer's misuse of the **STLHR** or the Buyer's negligence; (iv) use of the **STLHR** in a manner for which it was not designed or intended; (v) external causes such as, but not limited to, power failure or electrical power surges; (vi) improper storage or handling of the **STLHR** by Buyer; or (vii) use of the **STLHR** in combination with equipment not purchased directly from the Seller.

Any installation, maintenance, repair, service, relocation or alteration, or other tampering with, the **STLHR** performed by any individual or entity other than the Seller, without Seller's prior written approval, or any use of replacement parts not supplied by Seller, shall immediately void, and cancel this warranty. This warranty entitles to you specific rights, and you may also have other rights, which differ from state to state. No other warranties shall apply.

Section 20: Appendix A

LEXX™ pH Solution Measurement ProNatural® Brands pH Test Strip (HR-KT-0054)

Inspection Process:

1. Creating Test Solution:

Hydra Rinse® Pro-control:

After the completion of the Hydra Rinse® Pro-control cycle, drain LEXX™ solution from machine into a clean emptied catch bucket for collecting test solution (do not add used LEXX™ Cups to the drained solution in catch bucket)

Wand:

Allow solution to freely dispense into a catch bucket for a minimum of 30 seconds. Next collect at least 8 fl. oz. of solution into a clean emptied cup for collecting test solution.

2. Taking Measurement:

Submerge test strip (~2 inches in length from roll) in solution for 2 seconds. Compare wetted test strip immediately to the color scale.

3. Results:

Test strip should indicate ≤ 3.5 pH for an acceptable reading when testing with a LEXX™ pH Test Strip.

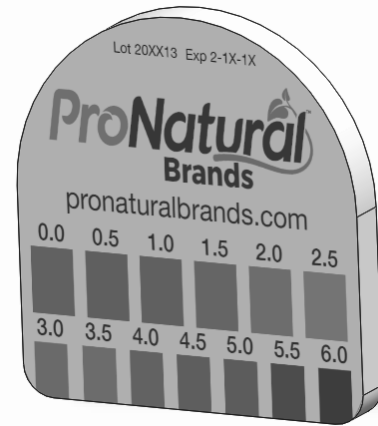

Section 20: Appendix A

LEXX™ Total Acid Concentration (grams/Liter) Semi-quantitative Measurement (Sold separately)

QUANTOFIX® Total acid (Part no. 91353)

Inspection Process:

-
-
-
-



1. Creating Test Solution:

Hydra Rinse® Pro-control:

After the completion of the Hydra Rinse® Pro-control cycle, drain LEXX™ solution from machine into a clean emptied catch bucket for collecting test solution (do not add used LEXX™ Cups to the drained solution in catch bucket)

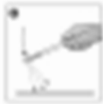

Wand:

Allow solution to freely dispense into a catch bucket for a minimum of 30 seconds. Next collect at least 8 fl. oz. of solution into a clean emptied cup for collecting test solution.



2. Taking Measurement:

Follow the instructions supplied with the QUANTOFIX® product to obtain the semi-quantitative total acid content.

3. Results:

Test strip should indicate between:
2.0-2.5 g/L



QUANTOFIX® Total acid

en

Description:
QUANTOFIX® Total acid are test strips for semi-quantitative determination of the total acid content. The total acid content is expressed as g of citric acid per L. QUANTOFIX® Total acid test strips are also suitable for reflectometric evaluation using the QUANTOFIX® Relax (REF 913 46).

Pack content:
1 aluminium can with 100 test strips

Measurement range

Visually
2-5 g/L citric acid

Color gradations:
0 - 2.0 - 2.5 - 3.0

General information

Always read the instructions

drawn from the

Instructions

1



Consult your local and state health codes for your requirements

*Recommend purchasing from CTL Scientific. Toll-Free: 888-686-3454

Intentionally Blank

101-1920 D



Standardizing Innovation

Thank You for your STLHR purchase!



Standardizing Innovation

101-1920 D