

# **Ice-O-Matic**<sup>®</sup>

Ice. Pure and Simple<sup>™</sup>



**ELEVATION SERIES CUBE ICE MAKER**

## **CIM Modular Cubers CIM0320 - CIM2046**



## **Technical Service Manual**

---

Introduction.....	1
Remote Condenser Installation.....	4
Electrical and Plumbing Requirements.....	7
Start-Up Procedure.....	10
Sequence of Operations.....	11
Control Board.....	25
Board Led Sequence During Operation Test.....	28
Button Functions.....	34
Sump.....	35
High and Low Float Switches and Housing.....	39
Water Pump.....	42
Water Distribution Tube.....	44
Water Inlet Valve.....	46
Purge Valve.....	47
Harvest Assist Assembly/Hot Gas Valve.....	48
Magnetic Curtain Switch.....	49
High Pressure Cut-out and Fan Cycle Switch.....	50
Fan Motor.....	51
Evaporator.....	52
High Temp Safety.....	60
Refrigeration Section.....	61
General Maintenance.....	63
Cleaning and Sanitizing.....	64
Cabinet Care.....	66
Winterizing Procedures.....	67
Technical Specifications.....	68
Wiring Diagram.....	71

## **Introduction**

### **Energy Efficiency**

Ice-O-Matic has partnered with ENERGY STAR since 2004 to ensure our customers receive the most efficient ice machines for your investment dollar. Ice-O-Matic is committed to the continuous improvement in both energy efficiency and productivity thereby delivering the best value in energy efficient ice machines money can buy.

For a detailed list of ENERGY STAR qualified Ice-O-Matic ice machines, go to:  
<http://www.iceomatic.com/Products/Sales-Literature/#>

### **Freight Claims**

#### **Inspect Promptly**

This merchandise has been carefully inspected and packed in accordance with the carrier's packing specifications. Responsibility for safe delivery has been assumed by the carrier. If loss or damage occurs, you as the consignee must file a claim with the carrier and hold the container for carrier's inspection.

#### **Concealed Loss or Damage**

If loss or damage does not appear until merchandise has been unpacked, make a written request for inspection by the carrier within 5 days of the delivery date, then file a claim on a form from the carrier.

#### **Visible Loss or Damage**

Any external evidence of loss or damage must be fully described and noted on your freight bill or express receipt and signed by the carrier's agent. The claim should be filed on a form available from the carrier.

**FILE CLAIMS WITHOUT DELAY**

**DO NOT RETURN DAMAGED GOODS  
TO ICE-O-MATIC**

### **How to use this Manual**

Ice-O-Matic provides this manual as an aid to the Refrigeration Service Technician for installation and maintenance of the CIM cube ice machines. Do not attempt to perform installation, start-up or maintenance unless you have read and fully understand this manual.

**Ice-O-Matic ice-makers and dispensers are not approved for outdoor installation.  
CIM Cubers contain R404A Refrigerant.**

**To find a Service Provider, please reference our "Find a Service Technician" tab at [www.iceomatic.com](http://www.iceomatic.com)  
Keep this manual for future reference.**

The CIM Series Service Parts Manuals are available separately.

#### **WARNING**

**Always disconnect electrical power and shut off water supply whenever maintenance or repairs are performed on the ice machine and related equipment.**

#### **CAUTION**

**Always wear protective eye wear whenever maintenance or repairs are performed on the ice machine and related equipment.**

### **Ice-O-Matic Warranty**

Every Ice-O-Matic ice maker is backed by a warranty that provides both parts and labor coverage. To view the warranty details, register products, or check your warranty status visit the "Warranty and Water Filter Registration" page on [www.iceomatic.com](http://www.iceomatic.com)

## **Installation Guidelines**

For proper operation of the ice machine, the following installation guidelines must be followed by **a qualified refrigeration technician**. Failure to do so may result in loss of production capacity, premature part failures, and may **void all warranties**.

Reference the installation parameters prior to installing the machine. Ice-O-Matic assumes no responsibility for improperly installed equipment. Excessive time required for service or time for units requiring removal for service of inaccessible equipment will be the sole responsibility of the equipment owner.

### **Ambient Operating Temperature**

Minimum operating temperature:  
50°F (10°C)

Maximum operating temperature:  
100°F (38°C) (60 Hz.), 110°F (43°C) (50 Hz.).

**Note: Ice-O-Matic ice-makers and dispensers are not approved for outdoor installation**

### **Incoming Water Supply**

**WARNING: Connect to unheated potable water supply only!**

(See Electrical and Plumbing diagrams for line sizing)

Minimum incoming water temperature:  
40°F (4.5°C)

Maximum incoming water temperature:  
100°F (38°C)

Minimum incoming water pressure:  
20 psi (1.4 bar, 0.138MPa)

Maximum incoming water pressure:  
80 psi (5.5 bar, 0.552MPa)

**Note: if water pressure exceeds 80 psi (5.5 bar), a water pressure regulator must be installed**

All water supply lines must be installed per local codes. Use 3/8 inch O.D. minimum on air cooled machines. On water cooled machines 3/8 inch O.D. minimum tubing must be run to the condenser. The water supply for the machine can “T” off from the condenser line using 3/8 inch O.D. minimum

tubing. Make 2 coils of extra tubing so that the machine can be pulled away from the wall if service is needed.

### **Water Filtration/Treatment**

A water filter system should be installed with the ice machine. Refer to Ice-O-Matic water filter specification sheet.

Reverse Osmosis (RO) water can be very acidic and can attack the evaporator and other metal in the ice machine. Because the RO process removes all minerals and metals from the water it can promote the faster growth of microbial mold and slime. If RO water is used, Ice-O-Matic recommends the water pH is verified to be a neutral 7.0 to minimize the corrosive effects. Incorrect cleaners, sanitizers, and RO water that does not have a neutral pH could **void the machine’s warranty**.

### **Drains**

All drain lines must be installed per local codes. Flexible tubing is not recommended. Route bin drain, purge drain and water condenser drain individually to a floor drain. The use of condensate pumps for draining water is not recommended. Ice-O-Matic assumes no responsibility for improperly installed equipment.

**Note: The Purge Drain Fitting is plastic: DO NOT apply heat to purge drain area; DO NOT over-tighten drain connection.**

The purge drain should be a minimum of 3/4 inch O.D. tubing. The condenser drain on water cooled units should be 1/2 inch O.D. minimum. The drain line fittings on Ice-O-Matic bins are 3/4 FPT. The bin drain should be a minimum of 3/4 inch O.D. Cold water drains should be insulated to prevent condensation from forming.

## Clearance Requirements

Self-contained air-cooled ice machines should have a minimum of 6 inches (15cm) of clearance at the rear, top and sides for proper air circulation and adequate space for serviceability.

Self-contained air-cooled ice machines exhaust air out the top and right side. There are two alternative air exhaust options. Option A (top exhaust bias): minimum of 6 inches (15cm) of clearance at the rear and top of the ice machine for proper function at maximum operating conditions. Option B (side exhaust bias): minimum of 6 inches (15cm) of clearance at the rear and right side of the ice machine with a minimum of 3 inches (7.5cm) of clearance at the top for proper function at maximum operating conditions.

Appropriate space should be allowed for proper serviceability of the machine. Excess time to gain access for serviceability is not covered under warranty.

## Stacking

Ice-O-Matic does not endorse stacking ice machines.

## Dispenser Application

A thermostatic bin control kit should be installed if the CIM Cube ice machine is placed on a dispenser. A bin top may or may not be required and should be secured to the dispenser.

## Electrical Specifications

Refer to the serial plate at the rear of the ice machine to make sure proper voltage and circuit breaker size have been supplied. Make sure the machine is on a dedicated circuit. European installations require that the electrical supply fixed wiring must be provided with a disconnect means having a separation of at least 3mm in all poles. The ice machines are provided **without** an electrical cord set and are designed and agency approved to be permanently connected.

### Units are not approved for GFI outlets.

**Caution:** Electrical connection must be made or a cord installed by a **qualified electrician** or there is danger of an electrical fire.

## Adjustments

Level the machine within 1/8 inch in all directions. Check the water in the Water Sump for proper level.

Check the ice bridge for proper thickness and adjust on Float Switch Housing Assembly as needed.

Check the Water Regulating Valve adjustment if water cooled.

Secure the machine on top of the bin or dispenser. Attach the ice machine to the bin with the mounting straps provided with the bin or dispenser. Insure that the back of the ice machine is flush with the back of the bin. Proper functioning of the Bin Door requires the door, when it is opened, to be in a stable position.

If the ice machine is too far forward on the bin, the opened door may not be stable, resulting in an unexpected closing of the bin door. If the ice machine is to be mounted on a bin or dispenser other than an Ice-O-Matic, refer to the manufacturers instructions for machine mounting. Ice-O-Matic will not be responsible for damage or injury that results from unexpected closing of the bin door as a result of the ice machine being too far forward on the bin.

## **Remote Condenser Installation**

For proper operation of the ice machine, the following installation guidelines must be followed.

Failure to do so may result in loss of production capacity, premature part failure, and may **void all warranties**.

### **Use the following for planning the placement of the remote condenser relative to the ice machine**

#### **Location Limits**

Remote condenser location must not exceed **ANY** of the following:

Maximum rise from the ice machine to the remote condenser is 35 physical feet.

Maximum drop from the ice machine to the remote condenser is 10 physical feet.

Physical line set maximum length is 75 ft.

Calculated line set length maximum is 100 ft.

Ambient operating temperatures:

-20°F (-28.9°C) to 120°F (48.9°C)

#### **Calculation Formula**

Drop = dd x 6.6

(dd = drop distance (ft.))

Rise = rd x 1.7

(rd = rise distance (ft.))

Horizontal Run = hd

(hd = horizontal distance (ft.))

Calculated Line Length = Drop + Rise + Horizontal Run

**Configurations that do NOT meet these requirements must receive written authorization from Ice-O-Matic. This includes multi-pass or rack system remote condensers.**

**DO NOT:** Route a line set that rises, then falls, then rises or a line set that falls, then rises, then falls.

#### **Remote Condenser Location**

Pre-charged line sets are available in 25, 40, 45, 60 or 75 foot length to connect the ice machine to the remote condenser. Select the best available location, protecting the remote condenser from extremes of dirt, dust and sun. Meet all applicable

building codes. The services of a licensed electrician may be required. Clearances required for the RCA/RGA Condensers are 48" above and 18" on all side of the unit for proper air flow.

#### **Roof Attachment**

Install and attach the remote condenser to the roof of the building using the methods and practices of construction that conform to the local building codes, including having a roofing contractor secure the remote condenser to the roof.

Have an electrician connect the remote condenser fan motor wires to the ice machine using the junction box at the back of the machine.

#### **Pre-charged Line Set Routing**

**CAUTION: Do not connect the pre-charged tubing until all routing and forming of the tubing has been completed. See the coupling instructions for connecting information.**

Each set of pre-charged tubing refrigerant lines consists of a 3/8" diameter liquid line and 1/2 inch diameter discharge line. Both ends of each line have quick connect couplings, one end of the line set has a Schrader valve connection.

**Note:** the openings in the building or ceiling or wall, listed in the next step, are the minimum sizes recommended for passing the refrigerant lines through.

Have a roofing contractor cut a minimum hole for the refrigerant lines of 2.50 inch. Check local codes, a separate hole may be required for the electrical power to the condenser.

**CAUTION: DO NOT KINK OR CRIMP REFRIGERANT TUBING WHEN INSTALLING IT.**

**NOTE: REMOTE LINES MUST NOT RISE AND DROP IN THE SAME RUN.**

Route the refrigerant lines through the roof opening. Follow straight line routing whenever possible. Any excess tubing **MUST** remain inside the building. Spiral the excess length of pre-charged tubing inside the building. Use a horizontal spiral to avoid any traps in the lines.  
Have the roofing contractor seal the holes in the roof per local codes.

**CAUTION: The couplings on the sets of pre-charged lines are self sealing when installed properly. Carefully follow the instructions in the Remote Condenser manual.**

The following remote ice makers incorporate the Mixing Valve in the Condenser. This configuration allows up to a 100 foot calculated remote line set run. Reference the diagram on the next page to calculate the maximum 100 ft. line set run. Maximum **actual line set run** is limited to 75ft.

CIM Machine Model Number	Remote Condenser Model Number
CIM0530R	VRC1001B/RCA1001
CIM0535R	VRC1061B/ <a href="#">RCA1061</a>
CIM0636R	VRC1061B/ <a href="#">RCA1061</a>
CIM0825R/0826R/0835R/0836R/0837R	VRC2061B/RCA2061
CIM1125R/1126R/1135R/1136R/1137R	VRC2061B/RCA2061
CIM1446R/1447R	VRC2661/RCA3061
CIM1545R/1845R	VRC2661/RCA3061
CIM2046R/2047R	VRC5061B/RCA3561

**Verify the CIM machine is compatible with the remote condenser.  
For more information contact your Ice-O-Matic distributor.**

## Equivalent Run Calculation Examples

**Formula for maximum equivalent run:**

**(RISE X 1.7) + (DROP X 6.6) + HORIZONTAL RUN = CALCULATED LINE RUN**

**NOT TO EXCEED 100 CALCULATED FEET**

### Rise:

$(35 \text{ ft.} \times 1.7) + (40 \text{ ft.}) = 99.5 \text{ calculated feet line run}$

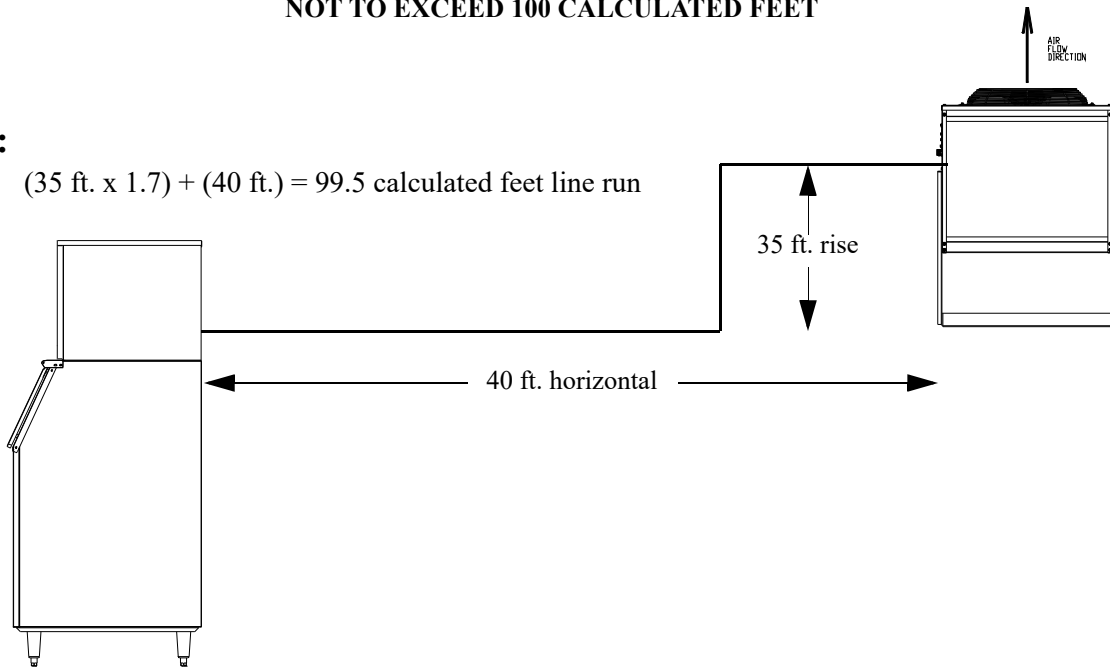

### Drop:

$(10 \text{ ft.} \times 6.6) + (34 \text{ ft.}) = 100 \text{ calculated feet line run}$

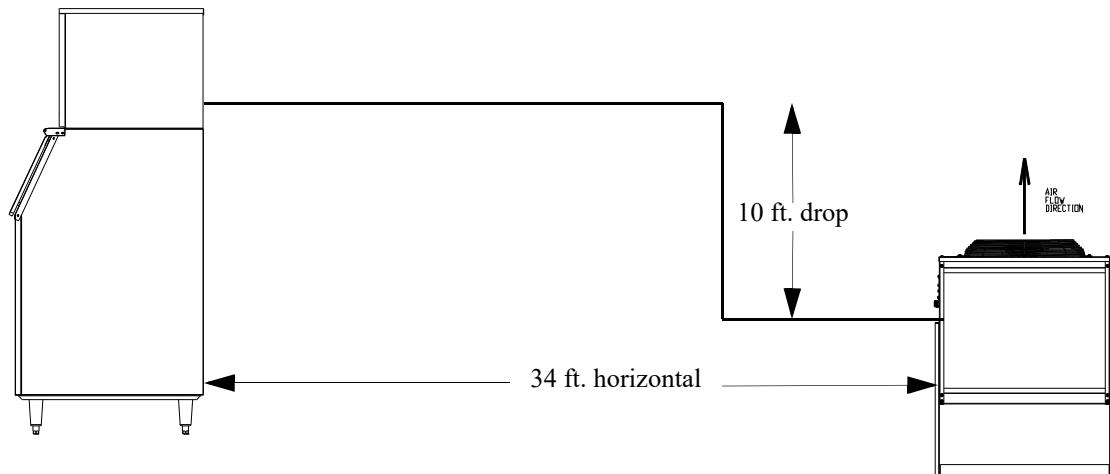



### 30" CIM SERIES Common Connections (CIM\*\*3\* A)

#### Air Cooled

Please note: air-cooled units require 6"(152mm) for air intake and exhaust.

- A. Ice maker potable water in, 3/8" FPT.
- B. Ice maker water out, 3/4" FPT.
- C. Hole for electrical connections, 7/8".
- D. Electrical junction box, 7/8".

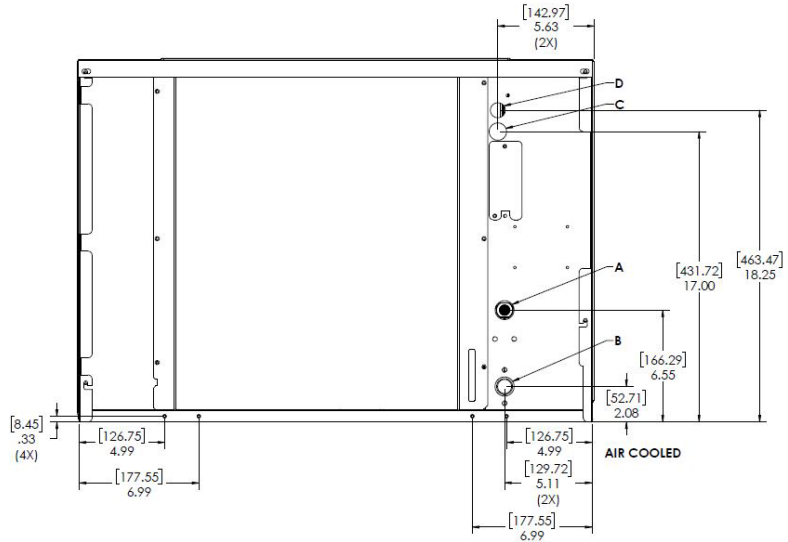

### (CIM\*\*3\* W/R)

#### Water/Remote Cooled

- A. Ice maker potable water in, 3/8" FPT.
- B. Ice maker water out, 3/4" FPT.
- C. Hole for electrical connections, 7/8".
- D. Electrical junction box, 7/8" (remote).
- E. Condenser water in, 3/8" FPT (water only). Discharge line, 1/2" male quick connect coupling for pre-charged line set (remote only).
- F. Condenser water out, 1/2" FPT (water only).
- G. Liquid Line, 3/8" male quick connect coupling for pre-charged line set (remote only).

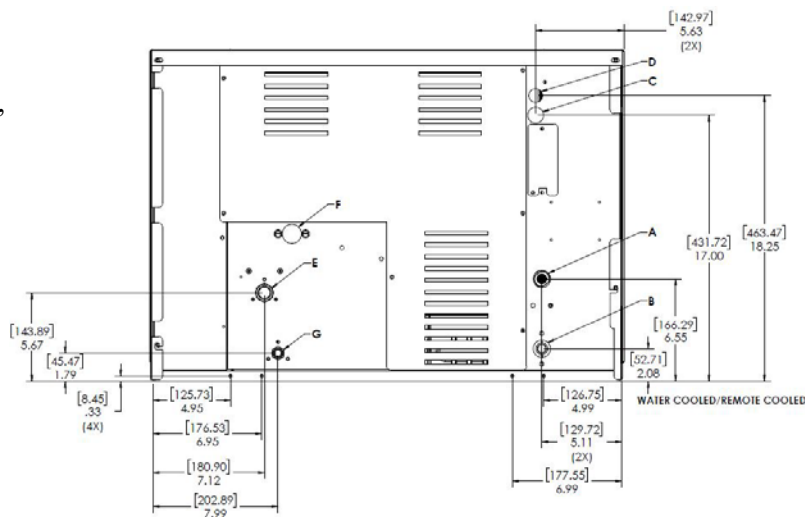

### 48" CIM SERIES Common Connections (CIM\*\*4\* A)

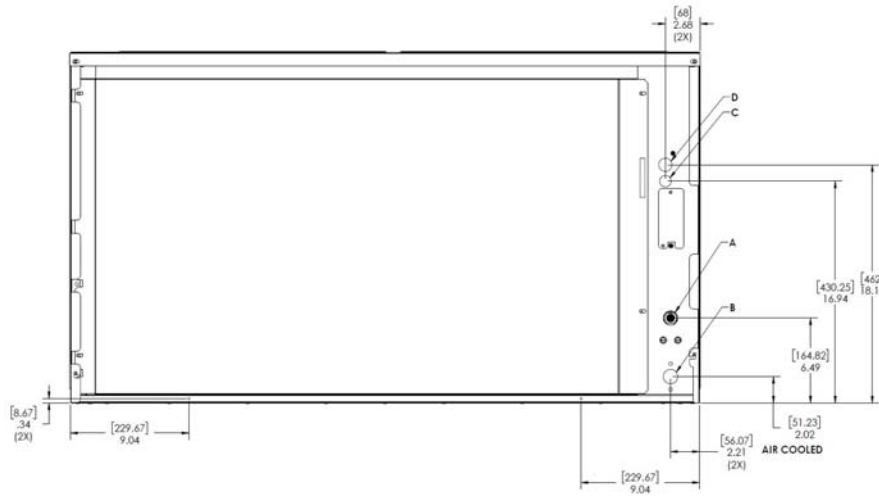

Please note: air-cooled units require 6”(152mm) for air intake and exhaust.

- |   |  |
|---|--|
| <ul style="list-style-type: none"> <li>A. Ice maker potable water in, 3/8” FPT.</li> <li>B. Ice maker water out, 3/4” FPT.</li> </ul> | <ul style="list-style-type: none"> <li>C. Hole for electrical connections, 7/8”.</li> <li>D. Electrical junction box, 7/8”.</li> </ul> |
|---|--|

### (CIM\*\*4\* W/R)

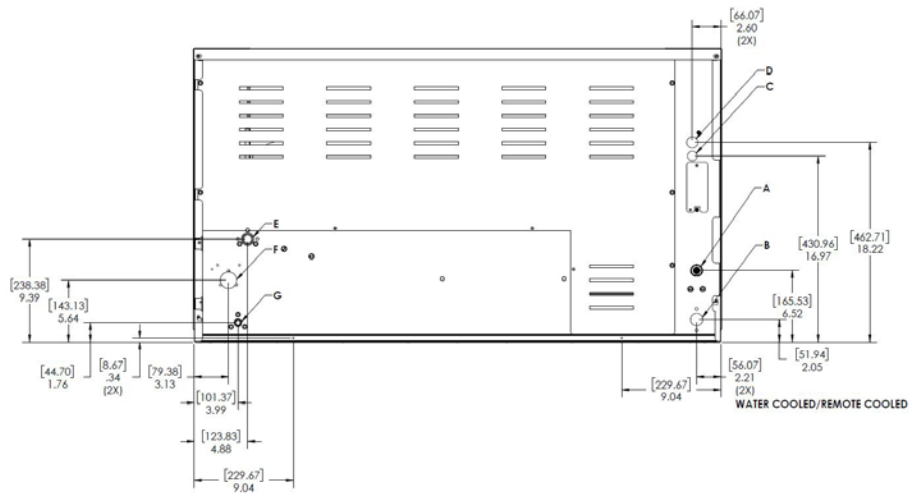

#### Water/Remote Cooled

- |  |  |
|--|--|
| <ul style="list-style-type: none"> <li>A. Ice maker potable water in, 3/8” FPT.</li> <li>B. Ice maker water out, 3/4” FPT.</li> <li>C. Hole for electrical connections, 7/8”.</li> <li>D. Electrical junction box, 7/8” (remote).</li> </ul> | <ul style="list-style-type: none"> <li>E. Condenser water in, 3/8” FPT (water only). Discharge line, 1/2” male quick connect coupling for pre-charged line set (remote only).</li> <li>F. Condenser water out, 3/4” FPT (water only).</li> <li>G. Liquid Line, 3/8” male quick connect coupling for pre-charged line set (remote only).</li> </ul> |
|--|--|

### Start-Up Procedure

Note: Before starting the machine, make sure the machine is level within 1/8 inch in all directions, the bin or dispenser leg height can be adjusted by rotating the leg foot

After verifying proper voltage, water supply, drains and breathable air space around the unit, press and quickly release the ON/OFF button behind the unit front panel. The indicator light will change from a solid red to solid blue in color.

Follow the sequence of operation described under “Operation of CIM Series Cuber” in this manual. Check operation of each component through the cycle as explained in this section.



Access to Water Level Adjustment

#### Bridge Thickness Adjustment

Once the unit has gone through a harvest cycle, verify the bridge thickness (3/16” thick for units less than 400 lbs. and 1/8” for 400 lbs. and above) across the middle of the ice slab on the second batch produced. The ice thickness can be changed on the Float Housing by turning the adjustment clockwise to decrease the bridge thickness and counter-clockwise to increase the bridge thickness. You will hear a “click” with each adjustment. It is recommended adjustments be made one or two “clicks” at a time.

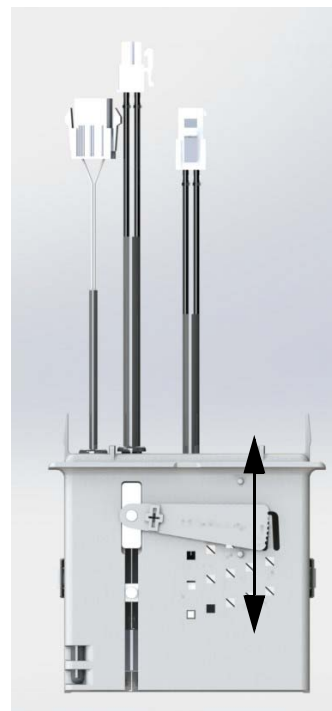

Lowers Float; increases bridge thickness

Raises Float; decreases bridge thickness

Model	Batch Weight		
	Half Cube	Full Cube	Grande Cube
CIM0320/0330	2.9-3.15	3.25-3.5	-
CIM0430/0520/0530/0630	4.9-5.15	5.5-5.8	-
CIM0820/0830/1120/1130	6.9-7.4	7.9-8.3	8.4-8.8
CIM1440/1540/1840/2040	13.8-14.8	15.8-16.6	-

**Sequence of Operations**

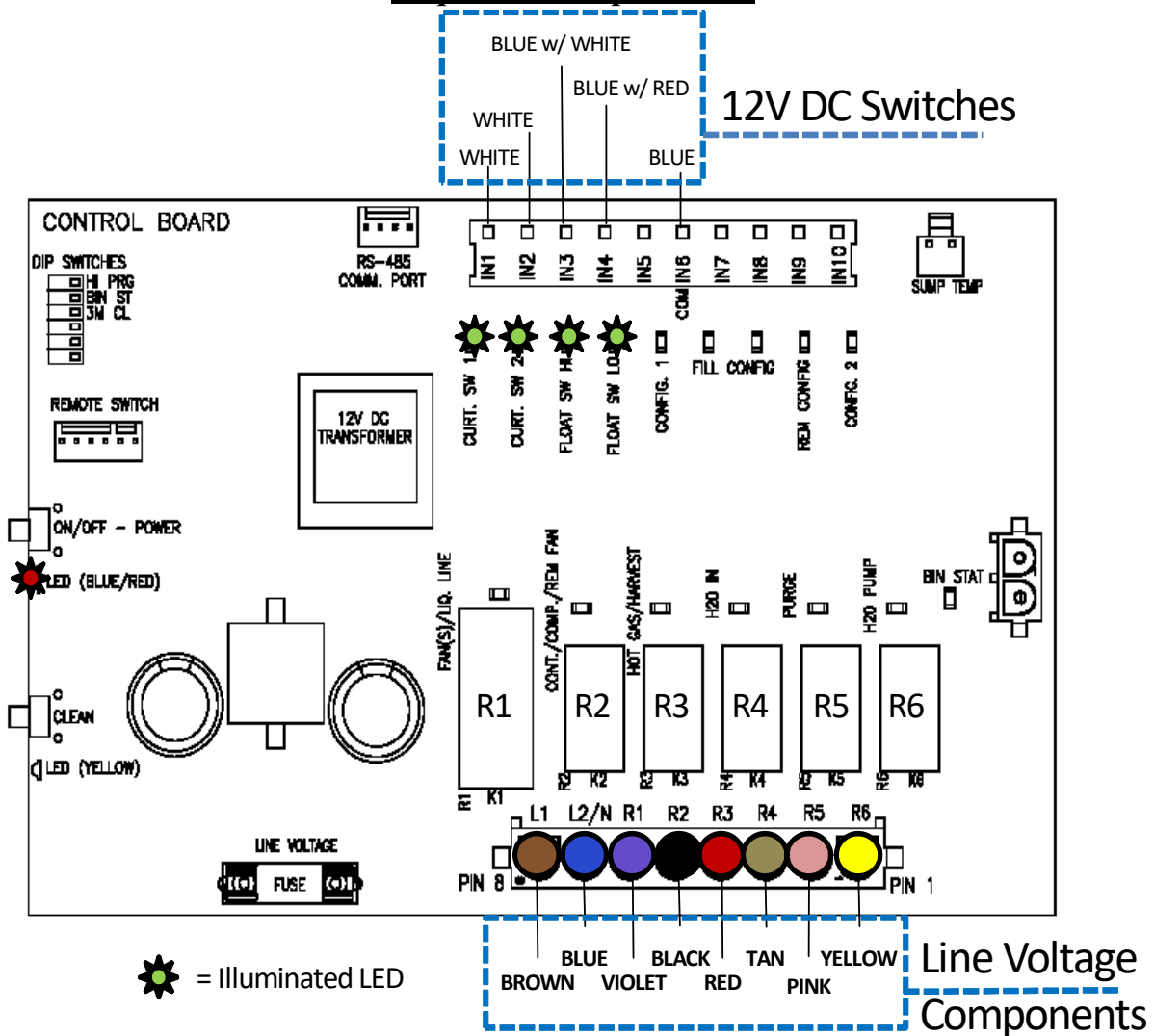

**CONTROL BOARD - OFF STATUS**

When power is initially applied to the unit, the LED's on both the Push Pad and the Board POWER Button will flash in sequence, then RED, then the WASH Button will flash YELLOW, followed by the POWER Button LED will turn a solid RED, indicating the unit is in the OFF status as shown above.

The LED's for the Curtain Switches (1 & 2), High Float Switch and Low Float Switch will be illuminated indicating closed circuits. Should the Curtains or Bin Thermostat (if added) be open, the unit will not start a Freeze Cycle.

From an OFF status, the unit can start a CLEAN cycle, a FREEZE cycle or be put in the DIAGNOSTIC mode. For Cleaning Instructions, see page 56. For more on the DIAGNOSTIC mode see page 30.

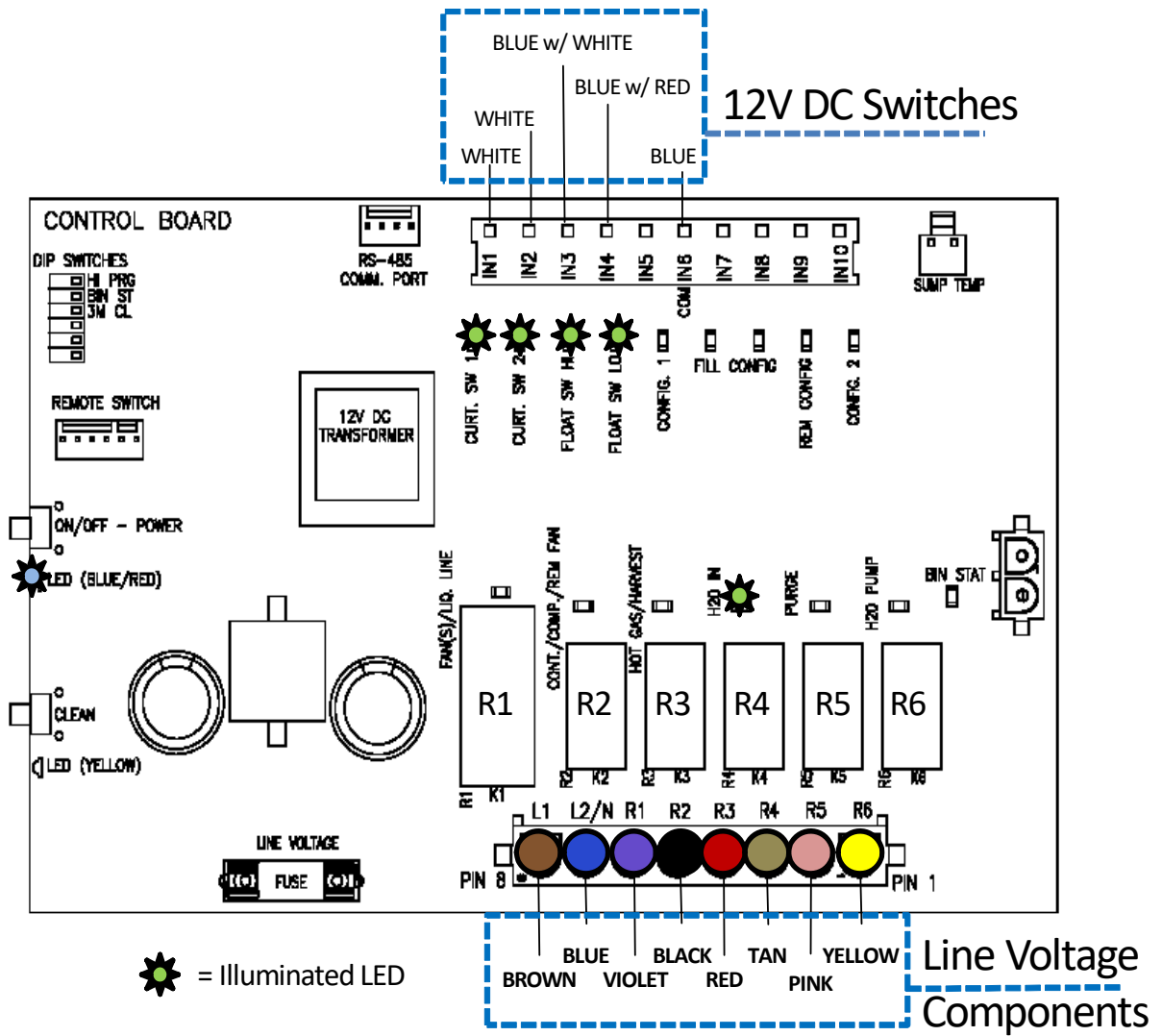

= Illuminated LED

**CONTROL BOARD - FREEZE CYCLE**

A quick press of the POWER button on the Push Pad or Board will start the Freeze cycle. The Water Inlet Valve will be energized (R4 LED on Board illuminated) and water will begin flowing into the Sump. As the water rises, the contacts in the Low Water Float will open (Switch LED off). The Water Inlet Valve will remain energized until the High Water Float contacts open (Switch LED off). The Water inlet Valve will be de-energized (R4 LED on Board off).

Note: Minimum Freeze Cycle - 5 minutes (from Compressor Start.)  
 Maximum Freeze Cycle - 1 hour.

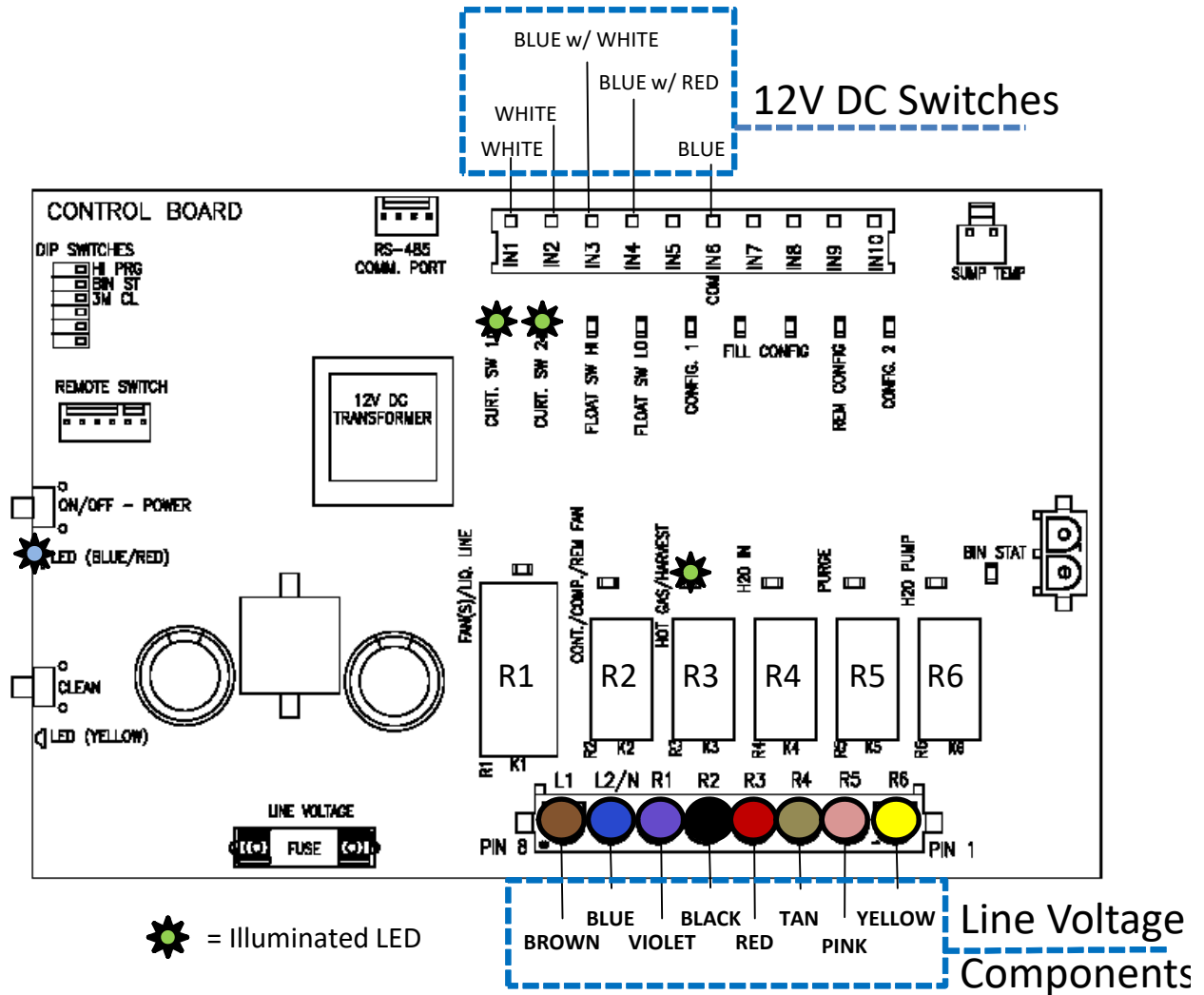

**CONTROL BOARD - COMPRESSOR START**

The Hot Gas Valve will be energized (R3 on Board illuminated) for 5 seconds and the system pressures will start to equalize.

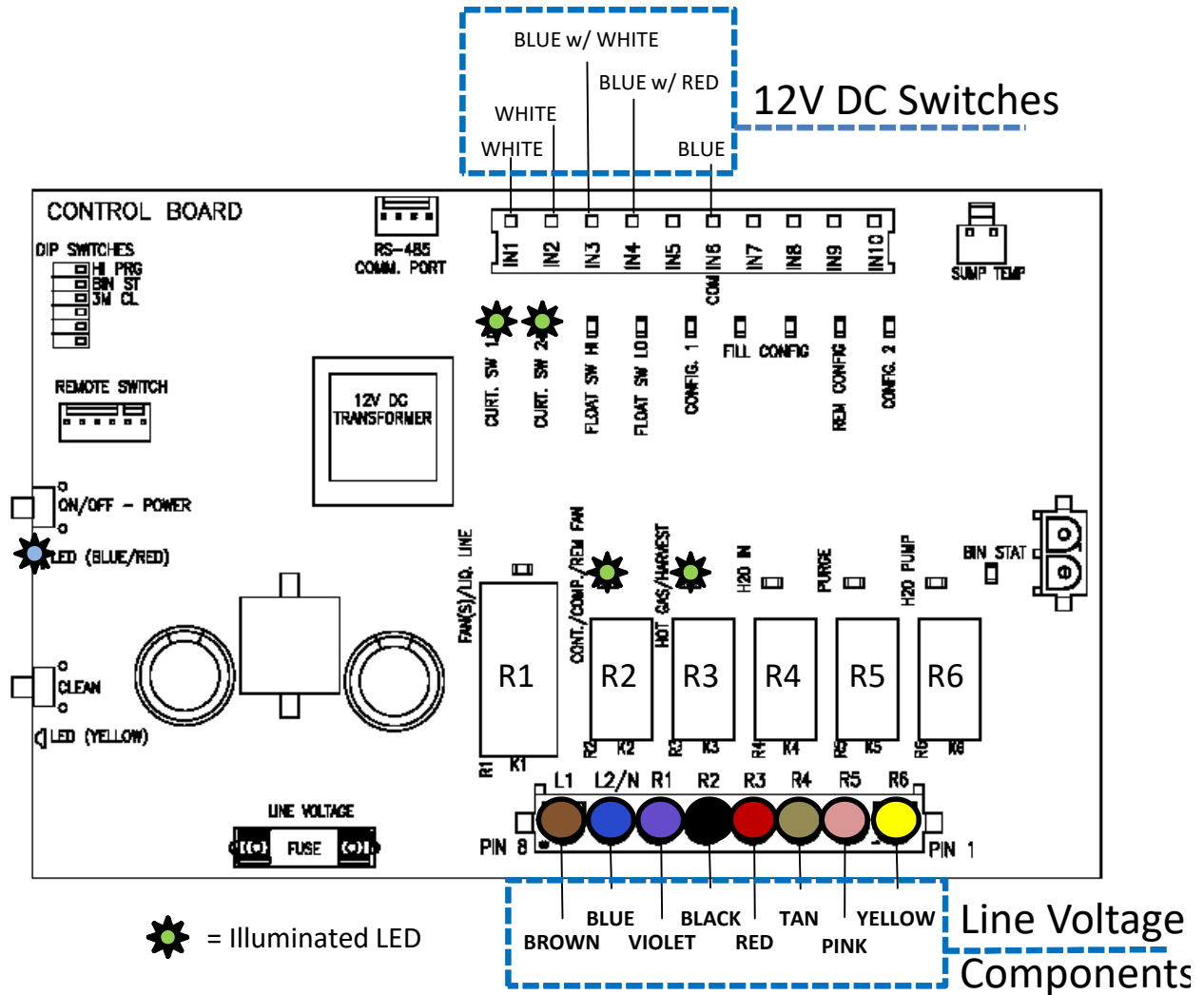

**CONTROL BOARD - COMPRESSOR START**

The Compressor will be energized (R2 on Board illuminated) and the Hot Gas Valve will remain open for 5 more seconds and then de-energize (R3 on Board off).

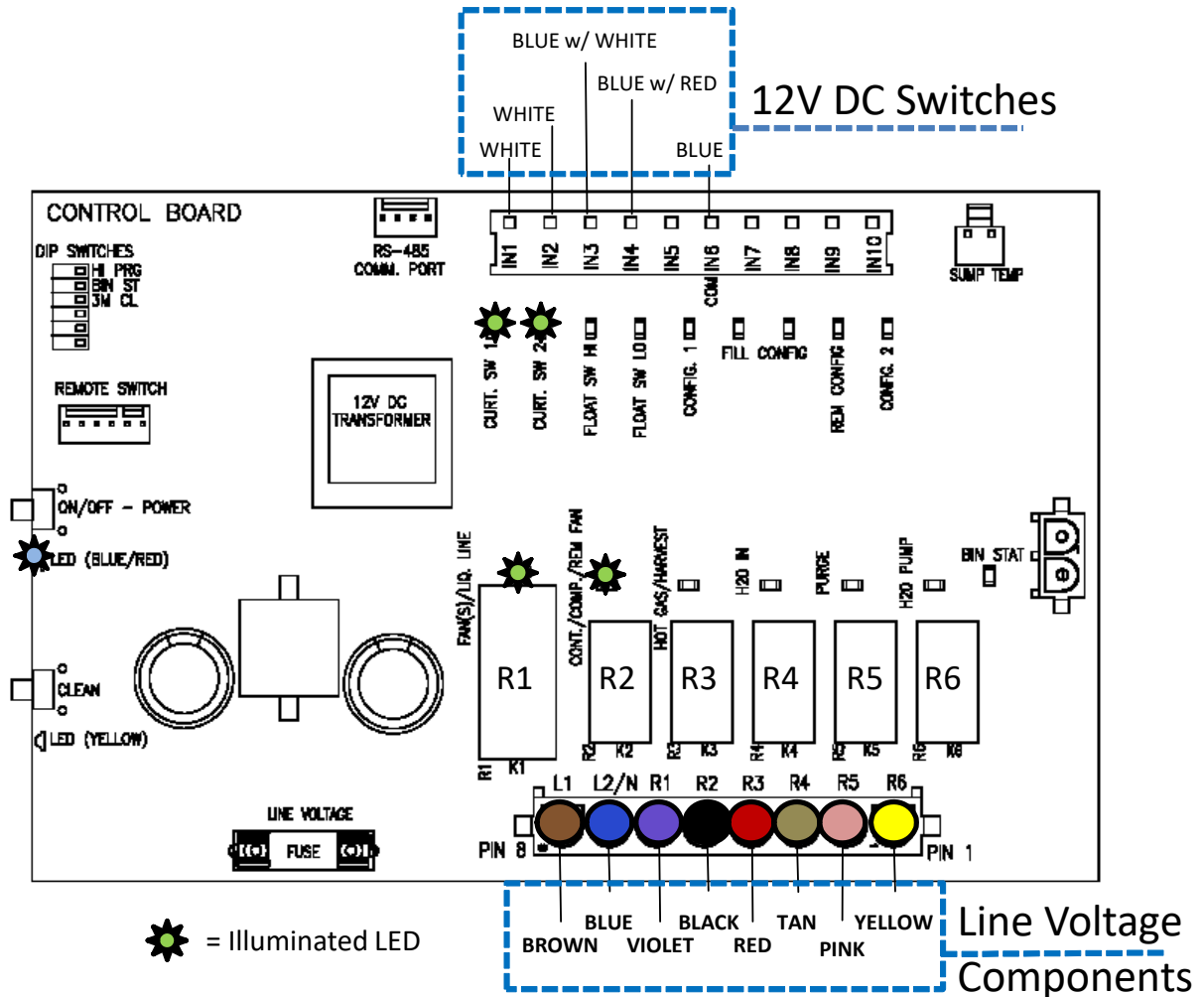

**CONTROL BOARD - PRE-CHILL**

The Compressor and Fan(s)/Liquid Line Solenoid (R1 and R2 LED's on Board illuminated) are energized and unit is now in a Pre-Chill for 30 seconds bringing the Evaporator temperature down. Both Curtain Switch LED's are on showing closed curtain(s). Even though (R1) is energized the Fan Motor will only come on once the Fan Cycle Switch closes at 250 psi of head pressure.

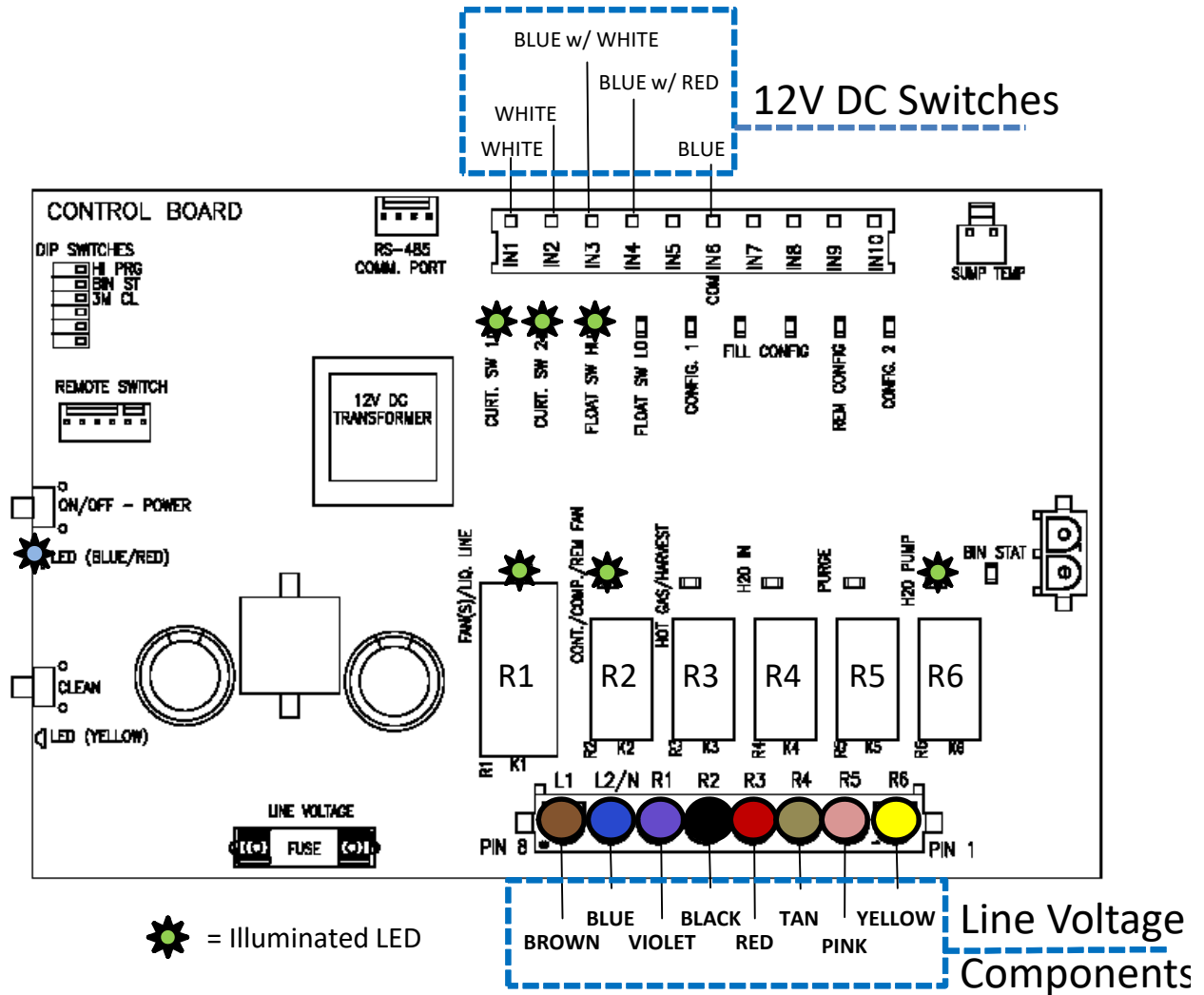

**CONTROL BOARD - FREEZE**

The Water Pump is energized (R6 LED on Board illuminated) and water is pushed through the Water Pump Tube and flows over the Evaporator. The High Float Switch contacts close as the water level in the Sump drops (High Float Switch LED on Board illuminates).

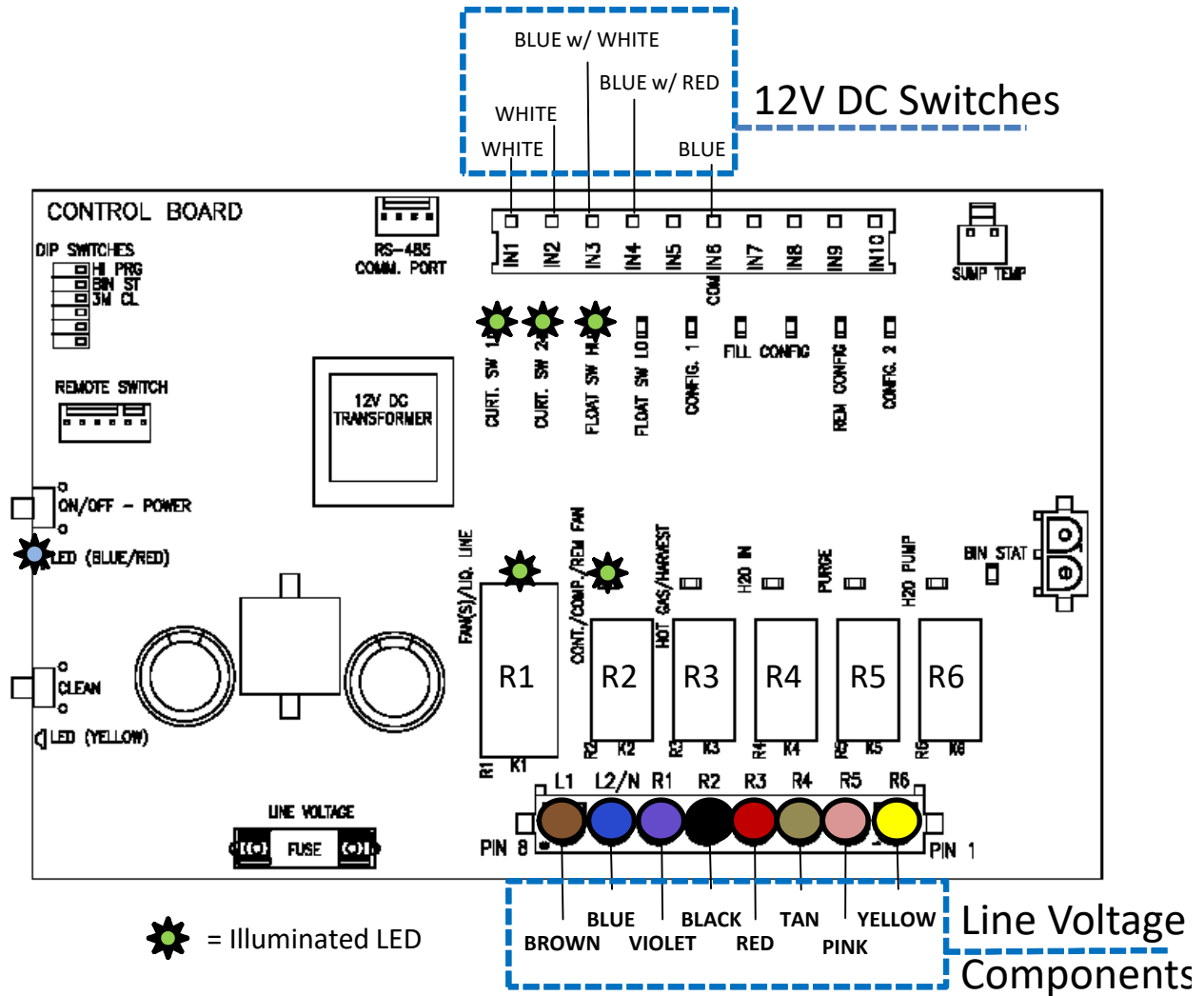

**CONTROL BOARD - ANTI-SLUSH**

During the first 3 cycles as the water temperature reaches 36 degrees F. the Water Pump will shut off for 20 seconds to reduce the possibility of slush developing in the Sump. After the first 3 cycles, Anti-Slush will only occur if the Sump water temperature reaches 28 degrees F.

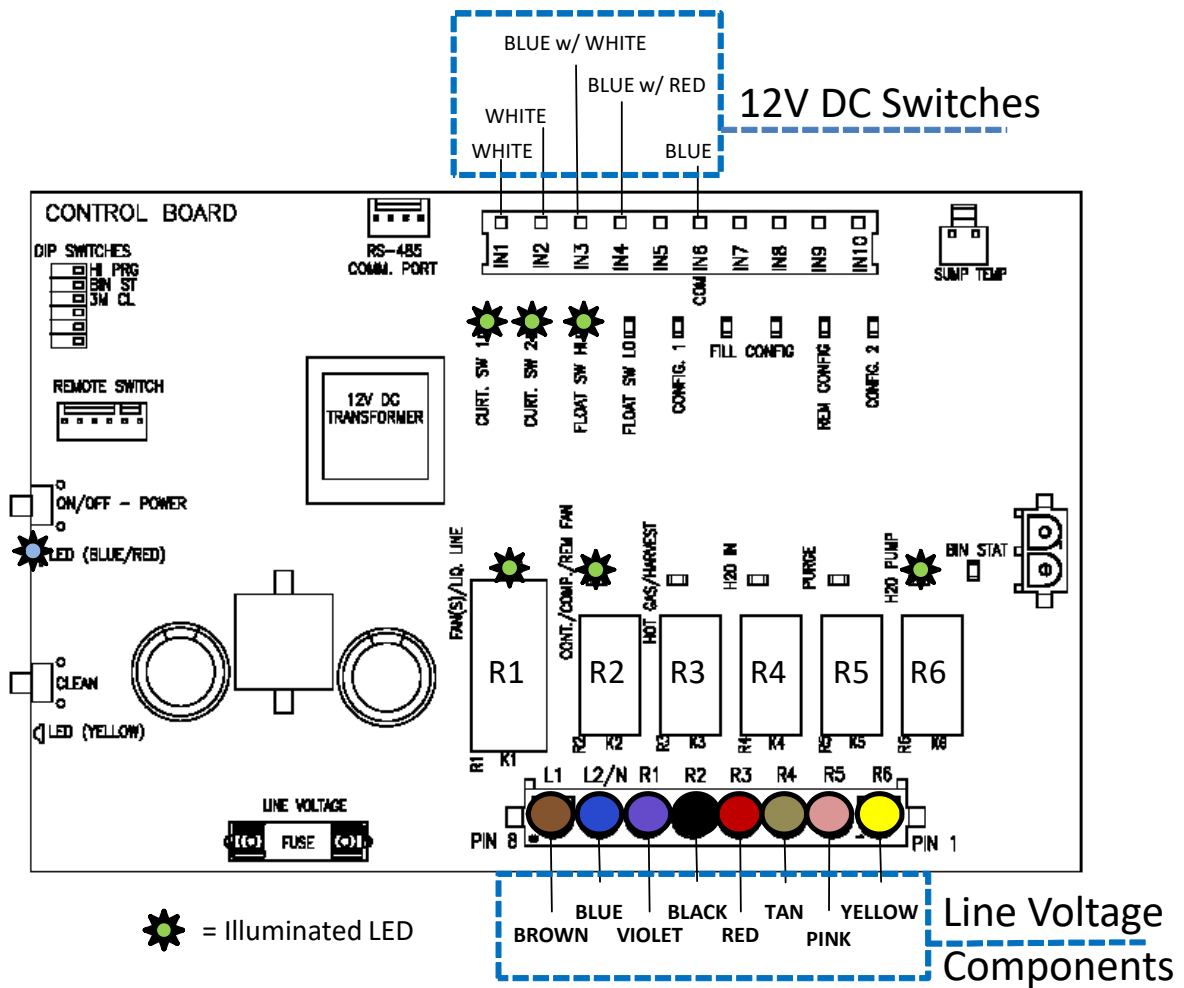

**CONTROL BOARD - WATER PUMP ON**

At the end of Anti-Slush the Water Pump (R6) will be re-energized and water starts flowing over the Evaporator again. The unit will stay in this mode until the Low Float Switch closes on water level drop, indicating the unit is ready to harvest.

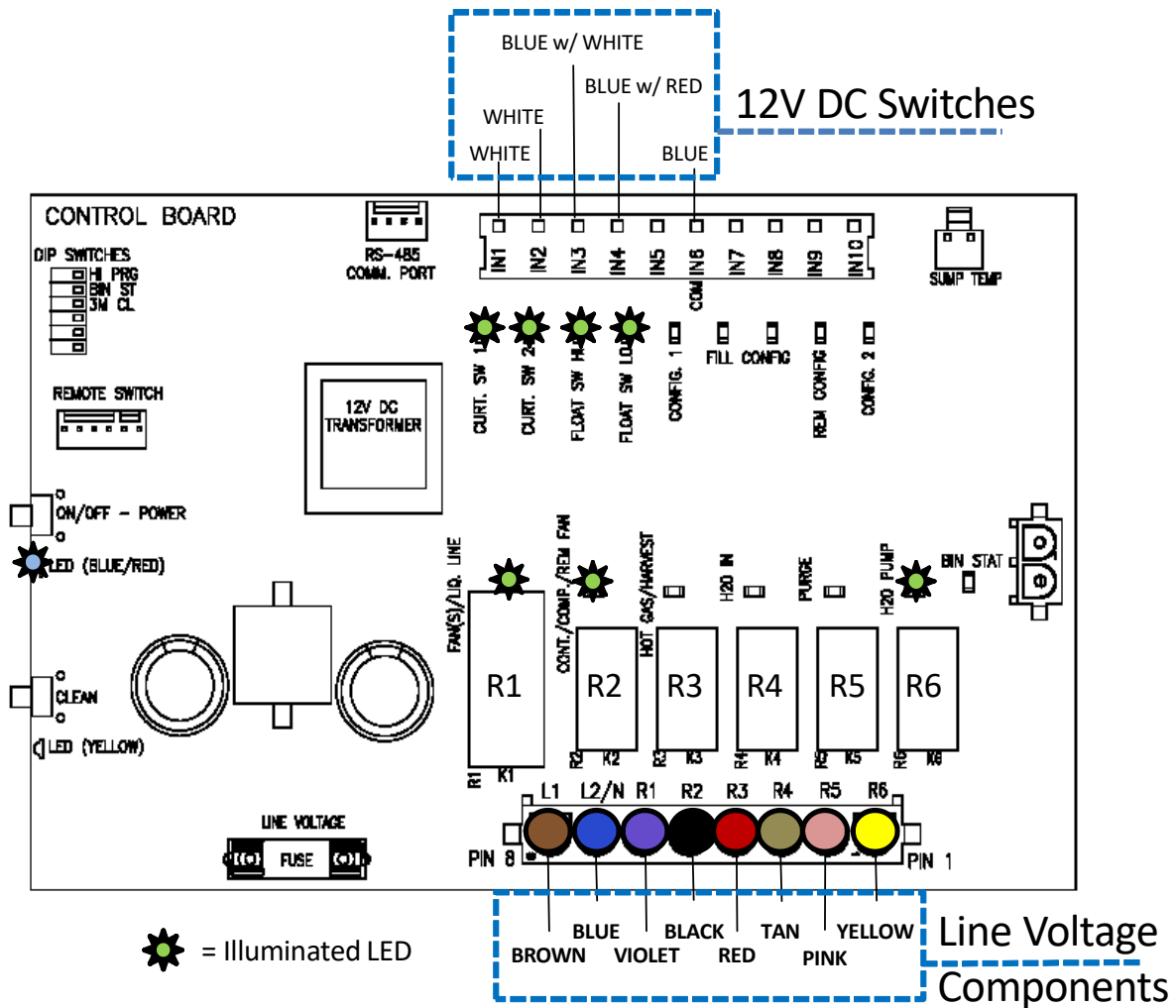

**CONTROL BOARD - INITIATING HARVEST**

When the water level in the SUMP drops to close the contacts of the Low Float Switch (LED on Board illuminates) after a 5 second de-bounce of the switch will signal the start of the Harvest Cycle.

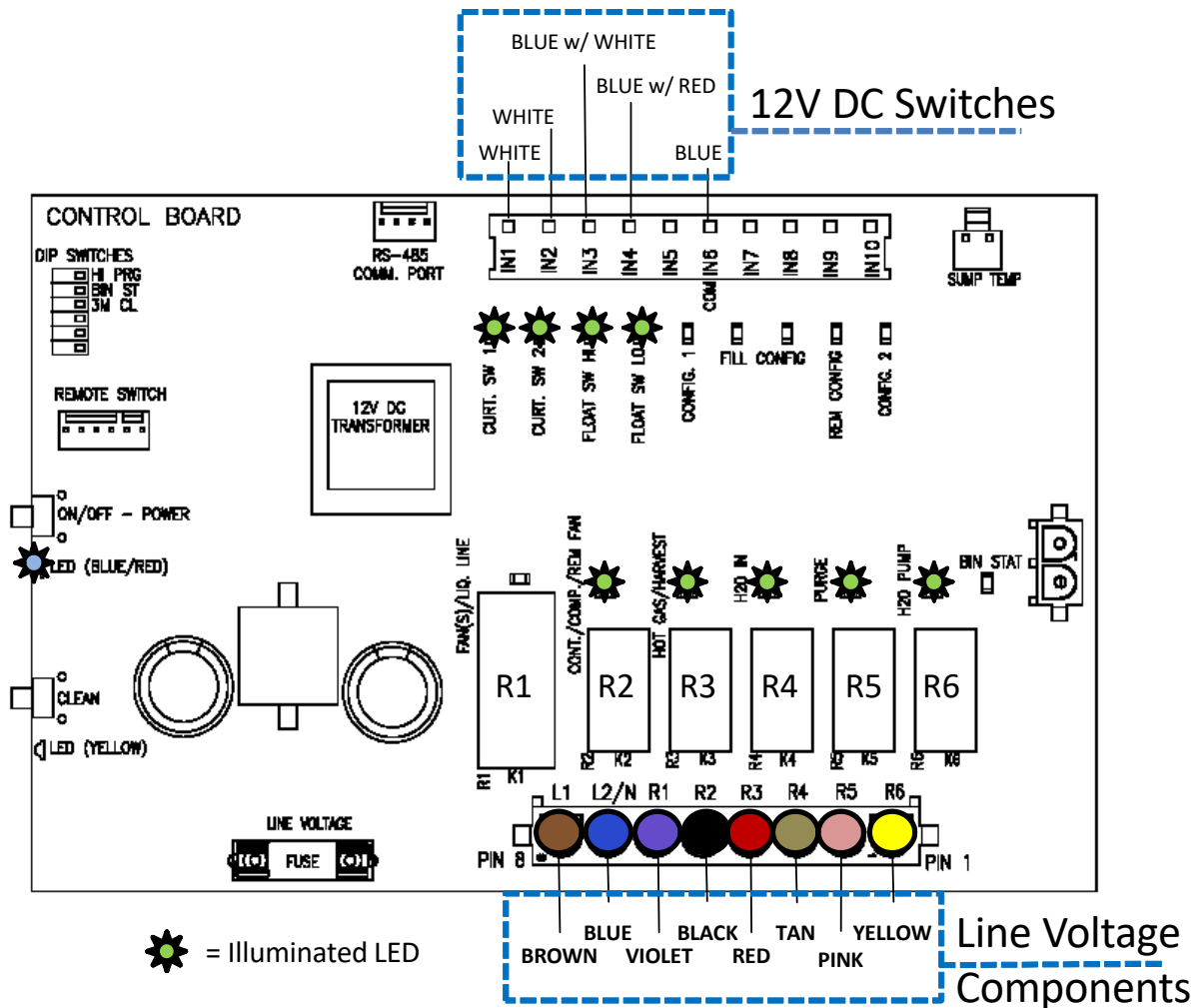

**CONTROL BOARD - HARVEST**

After the contacts of the Low Float Switch close, the Harvest Cycle starts by energizing the Hot Gas Valve, Harvest Assist, Purge Valve AND Water Inlet Valve (R2, R3, R4, R5 and R6 are illuminated on Air and Water Cooled units, ALL Relays are energized on Remotes.) The Purge Valve will close after 7 seconds.(Default Setting)

NOTE: Minimum harvest time is 20 seconds. Maximum harvest time is 5.5 minutes.

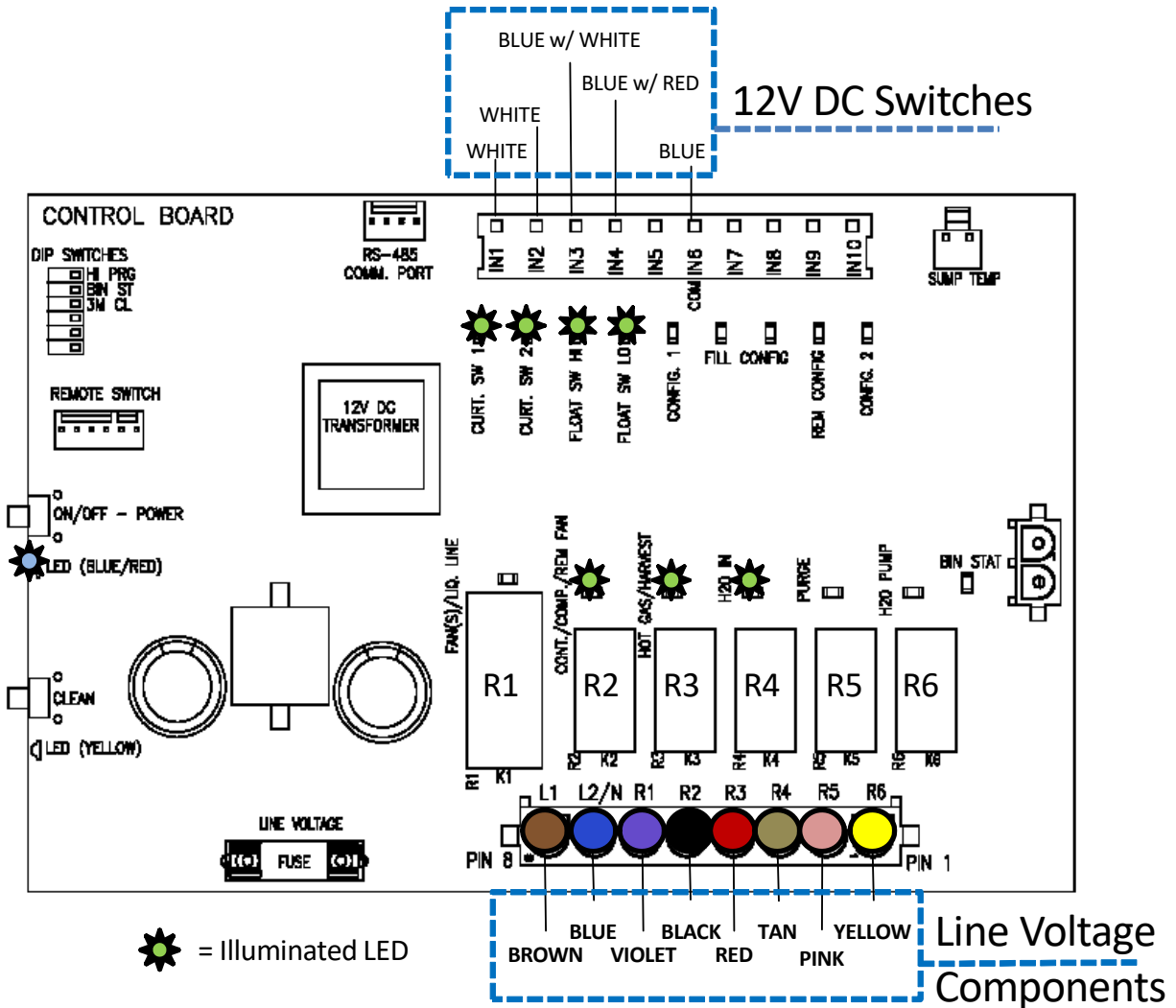

**CONTROL BOARD - HARVEST**

After the Purge Valve and Water Pump de-energize, the Water Inlet Valve will remain open for 20 seconds, partially filling the SUMP in preparation for the next Freeze Cycle (R2, R3, and R4, are illuminated on Air and Water Cooled units, R1 is also energized on Remotes.) The Low Float Switch will go off as the water level rises.

The Hot Gas Valve and Harvest Assist will remain energized for the remainder of the Harvest Cycle.

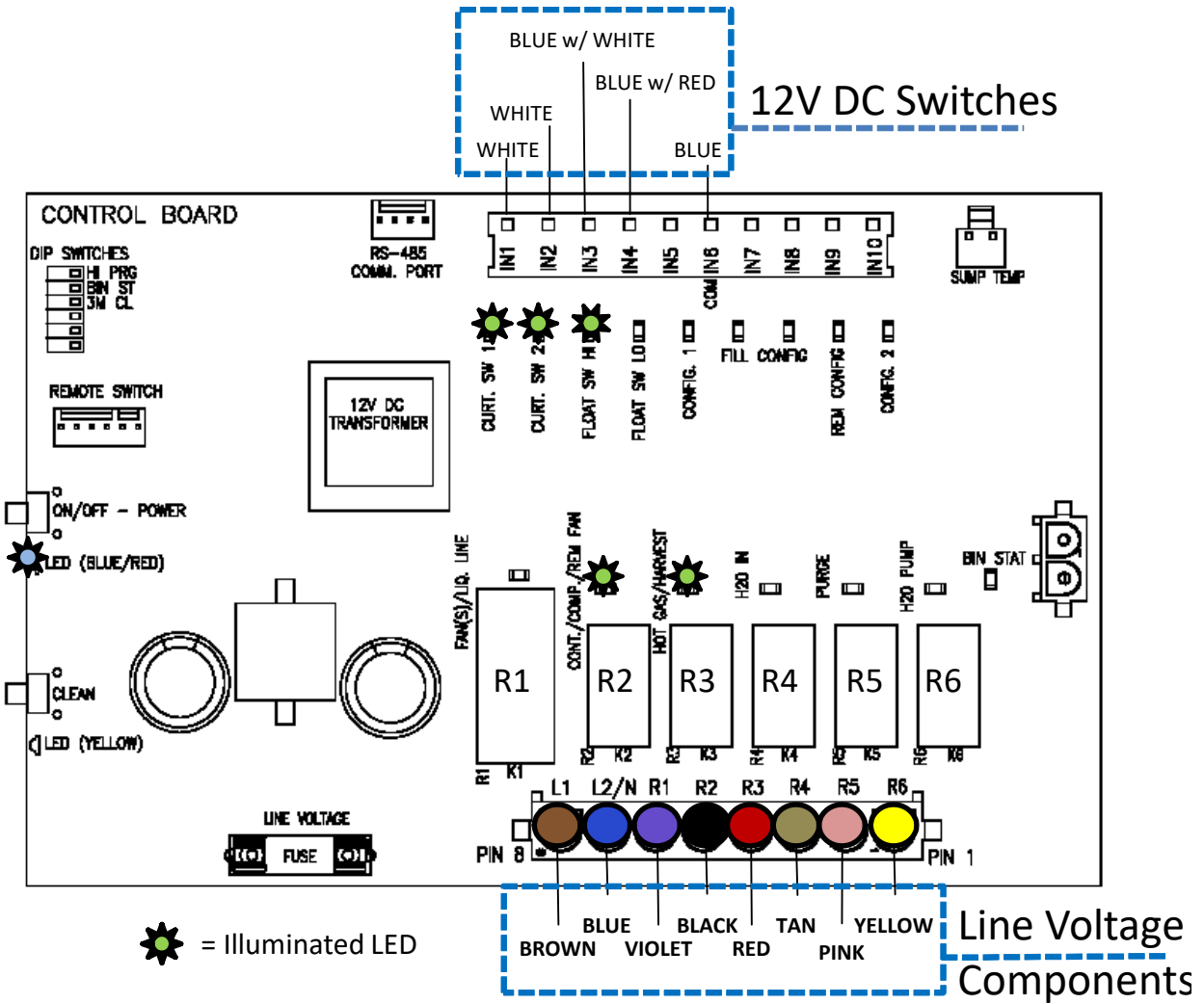

**CONTROL BOARD - HARVEST**

After the Water Inlet Valve closes following the 20 second time out, the Hot Gas Valve and Harvest Assist will remain energized until the ice slab is harvested from the Evaporator. At this point the unit is reading the Curtain Switch (s) and/or Bin Thermostat (if added).

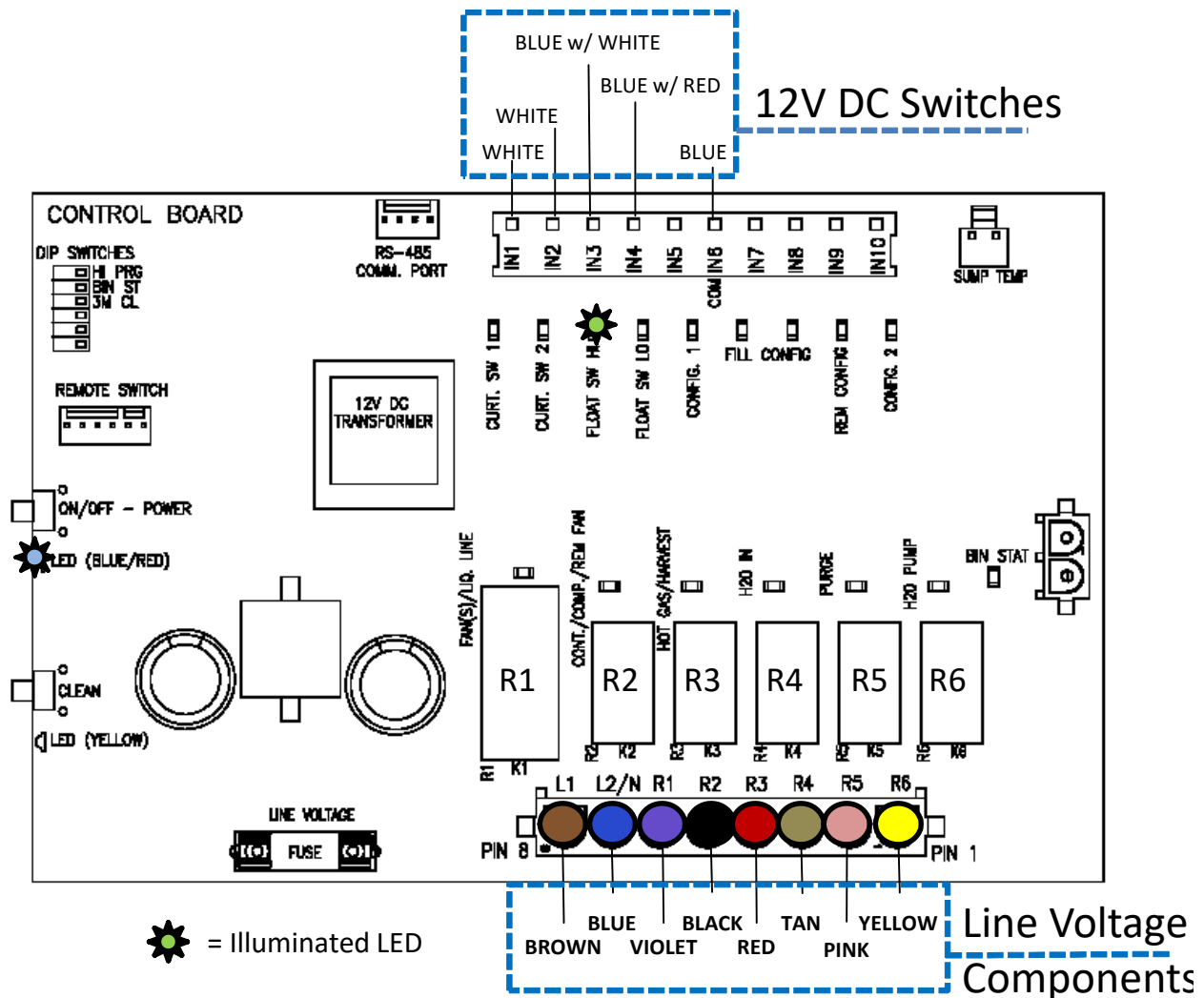

**CONTROL BOARD - BIN FULL**

As the ice slab falls from the Evaporator, the Curtain(s) is pushed out, contacts of the Magnetic Curtain Switch(s) open as the ice slab falls. If the Curtain(s) remains open for 30 seconds, the unit will shut down on a full bin. All RELAY LED's (R1 - R6) will go off. If the storage is not full, the unit will restart the next cycle. See pg. 28.

Anytime the unit is turned off or cycles off on a full bin due to a Curtain Switch being open for 30 seconds and/or an added Bin Thermostat remaining open for 90 seconds, the unit will not restart for 3 minutes, preventing a Compressor short cycle.

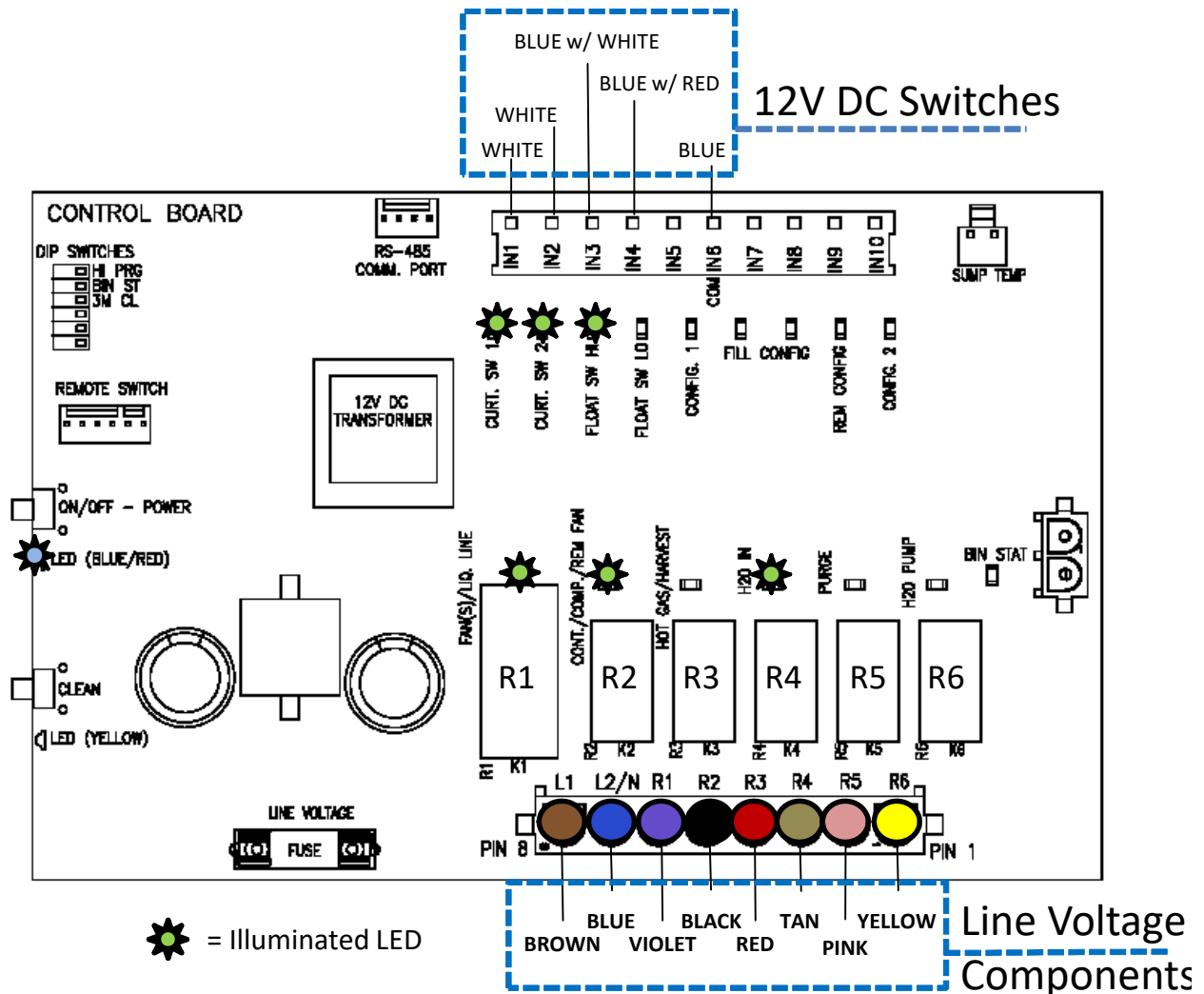

**CONTROL BOARD - RETURN TO FREEZE**

As the ice slab falls from the Evaporator, the Curtain(s) is pushed out and the contacts of the Curtain Switch(s) open and close, terminating the Harvest Cycle. With a closed Curtain and Bin Thermostat (if added), the unit will restart the Freeze Cycle. The Compressor (R2) and Fan(s) (R1) will continue operation as the Water Inlet Valve (R4) is energized to fill the Sump until the High Water Float opens.

## Control Board

### Operation

The Board controls the operation of the unit. A series of LED lights show Switch positions and Component operation to assist the technician in understanding and troubleshooting issues that may arise. See Sequence of Operation pg. 9 for operational information.

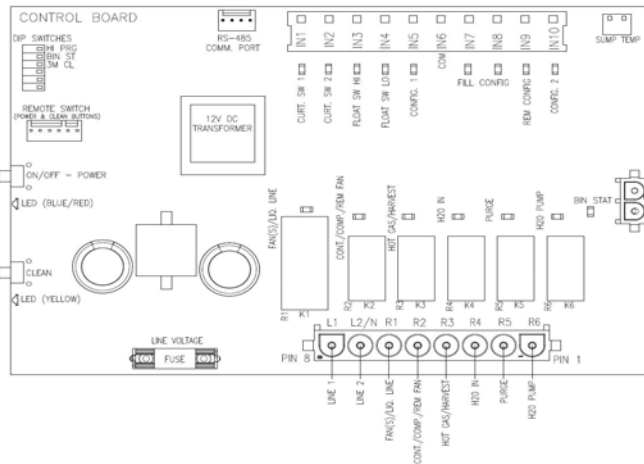

### Control Board Features

Adjustment Switch Block

12V DC Molex for Control Switch

Thermistor Molex

Power Button/LED

Bin Stat Connection

Clean Button/LED

Control Relays

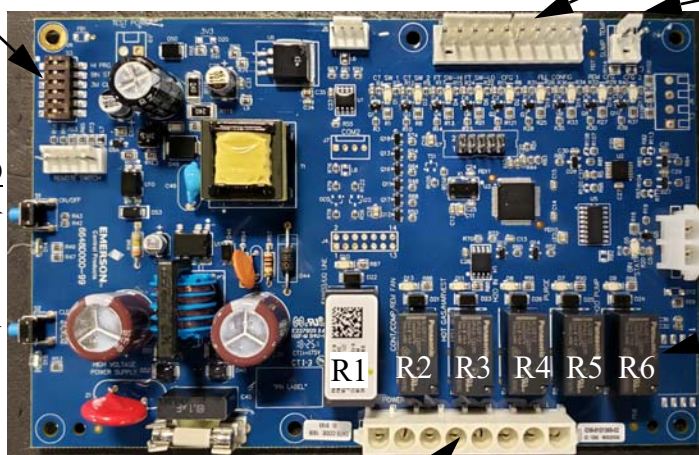

Line Voltage Molex for Energizing Components

### **Adjustment Switch Block**

Three adjustments can be made on the block. Extended Purge, Bin Thermostat Kit add-on and Cleaning Needed Reminder.

Standard Purge time during a Defrost Cycle is set at 7 seconds. To add an additional 5 seconds to the purge time, move Switch 1 to the right, to the ON position.

Should the unit be installed on top of a dispenser, a Bin Thermostat Kit is required. Following the instruction that come with the kit, Switch 2 needs to be moved to the ON position to tell the program to read the Bin Thermostat. The LED beside the Bin Stat Connection will then illuminate. The Switch 3 on the block is for the Cleaning Needed Reminder. When in the OFF position, the default setting for the reminder is 6 months. When Switch 3 is moved to the ON position, the Reminder is set for every 3 months. This is recommended should the unit be installed in a hard water location to help with production levels.

### **12V DC Molex for Control Switches**

This Molex connects the Magnetic Curtain Switch(es), High Float Switch, Low Float Switch and Remote Configuration Switch to the Board. The LED's associated to each switch will illuminate when the contacts for each are closed. The Remote Configuration LED will be illuminated when the Smart Harness reads the unit has a Remote Condenser. The Configuration 1 and both Fill Configuration LED's are not used as of the printing of this manual.

### **Thermistor Molex**

The Thermistor is used to gauge the water temperature in the Sump and is used to activate the Anti-Slush Cycle. When the water temperature reaches 36 degrees F during the first 3 cycles following a full bin situation, being restarted after a loss of power or turned off, the Water Pump will be turned off for 20 seconds to help prevent slushing of the water in the Sump. An Anti-Slush will also be performed any time the water temperature reaches 28 degrees F.

### **Control Relays**

The six Control Relays send voltage out to the individual components during the operation of the unit. Relay 1 energizes the Fan(s) on self contained air cooled units or the Liquid Line Solenoid on Remotes. Relay 2 energizes the Compressor through the Contactor (and Fan Motor on Remotes). Relay 3 energizes the Hot Gas Valve and Harvest Assist Assembly during the Harvest Cycle. Relay 4 energizes Water Inlet Valve. Relay 5 energizes the Purge Valve. Relay 6 energizes the Water Pump.

### **Line Voltage Molex**

The Line Voltage Molex connects for each component to the Board. See the wiring diagram for each unit to see the wiring colors associated with each component.

### **Power and Clean Buttons**

These buttons are functional duplicates of the buttons on the Push Pad mounted to the front frame of the unit. See also "Button Function" chart in this manual for operation.

**Power and Clean LED Flash Description**

SOLID - On Constantly

SLOW - Flashes once every second

QUICK - Flashes once every half second

DOUBLE SLOW - Flashes twice then 1 second delay

DELAYED - flashes once every 3 seconds

**Error Codes**

Error 1 - POWER LED QUICK FLASH RED - Unit has experienced a MAX Freeze (1 hr), MAX Harvest (5.5 minutes) or BOTH.

Error 2 - POWER LED SLOW FLASH IN OFF STATE ONLY - Thermistor Failure.

Error 3 - POWER LED RED AND CLEAN LED YELLOW QUICK FLASH - Unit has experienced a MAX Fill (5 min) or MAX Purge (2 min).

**Minimum / Maximum Times**

Freeze - 5 Minute Minimum / 1 Hour Maximum

Standard Harvest - 20 Second Minimum / 5.5 Minute Maximum

Water Fill - No Minimum / 5 Minute Maximum

Purge - 7 Second Minimum / 2 Minute Maximum

**Board Led Sequence During Operation Test**

INITIAL FREEZE CYCLE AT START-UP

<u>INITIAL FREEZE AT START-UP</u>		<u>FREEZE</u>							
		<u>POWER LED SOLID BLUE</u>							
<u>COMPONENTS</u>	<u>RELAY #</u>	<u>OFF</u>	<u>FILL VERIFICATION</u>	<u>PRESSURE EQUALIZE</u>	<u>PRESS. EQ. W/ COMPR.</u>	<u>PUMP DELAY</u>	<u>FREEZE</u>	<u>ANTI-SLUSH</u>	<u>FREEZE</u>
FAN(S) W/FAN CYCLE (A & W)	R1	-	-	-	ON	ON	ON	ON	ON
LIQ. LINE VALVE (REMOTE)	R1				ON	ON	ON	ON	ON
CONTACTOR/COMPRESSOR/REM. COND. FAN	R2	-	-	-	ON	ON	ON	ON	ON
WATER PUMP	R3	-	-	-	-	-	ON	-	ON
HOT GAS VALVE(S)	R4	-	-	ON	ON	-	-	-	-
HARVEST ASSIST(S)		-	-	-	-	-	-	-	-
WATER INLET VALVE	R5	-	ON	-	-	-	-	-	-
PURGE VALVE	R6	-	-	-	-	-	-	-	-
NOTES:		VERIFY CONFIG 1 (PUMP DOWN FOR REM ONLY)	HIFLOAT SW. OPEN	COMPRESSOR START UP - APPROX 5 SEC	COMP. START UP - HGV CLOSES AFTER APPROX 5 SEC.	PRE-CHILL THE EVAP PLATE - APPROX 30 SEC.	FREEZE	AT SUMP TEMP 36F. TURN OFF PUMP - APPROX 20 SEC.	CONTINUE FREEZE TO LOW FLOAT SW. CLOSE

INITIAL HARVEST CYCLE AT START-UP

INITIAL CYCLE AT START-UP (CONTINUED)		HARVEST					
		POWER LED SOLID BLUE					
COMPONENTS	RELAY #	PURGE ON ENTERING HARVEST	TIMED FILL	WAIT FOR HARVEST	CURT. SW. OPENS		
FAN(S) W/FAN CYCLE (A & W)	R1	-	-	-	-	-	
LIQ. LINE VALVE (REMOTE)	R1	ON	ON	ON	ON	ON	
CONTACTOR/ COMPRESSOR/ REM. COND. FAN	R2	ON	ON	ON	ON	ON	
WATER PUMP	R3	ON	-	-	-	-	
HOT GAS VALVE(S) HARVEST ASSIST(S)	R4	ON	ON	ON	ON	ON	
WATER INLET VALVE	R5	ON	ON	ON	ON	ON	
PURGE VALVE	R6	ON	-	-	-	-	
NOTES:		TIMED SUMP FLUSH AND PURGE - APPROX 7 SEC.	INITIAL TIMED FILL 20 SECS. OR TO HIGH FLOAT SW. OPEN	WAITING FOR CURTAIN SW. OR BIN STAT	ICE RELEASED - HARVEST TERMINATED		

TRANSITION FROM HARVEST TO FREEZE

TRANSITION HARVEST -> FREEZE		CONTROLLER STATES													
		HARVEST					FREEZE								
		POWER LED SOLID BLUE													
COMPONENTS	RELAY #	HOT GAS-HAA/ PURGE/ WATER INLET	HOT GAS- HAA/TIMED FILL	HOT GAS/HAA	CURTAIN SW (1 & 2) OPEN	CURTAIN SW (1 & 2) CLOSE	PRE-CHILL AND FILL	FREEZE							
FAN(S) W/FAN CYCLE (A & W)	R1	-	-	-	-	-	ON	ON	ON	ON	ON	ON	ON	ON	ON
LIQ. LINE VALVE (REMOTE)	R1	ON	ON	ON	ON	ON	ON	ON	ON	ON	ON	ON	ON	ON	ON
CONTACTOR/ COMPRESSOR/ REM. COND. FAN	R2	ON	ON	ON	ON	ON	ON	ON	ON	ON	ON	ON	ON	ON	ON
WATER PUMP	R3	ON	-	-	-	-	-	-	-	-	-	-	-	-	ON
HOT GAS VALVE(S) HARVEST ASSIST(S)	R4	ON	ON	ON	ON	ON	ON	ON	ON	ON	ON	ON	ON	ON	-
WATER INLET VALVE	R5	ON	ON	ON	ON	ON	ON	ON	ON	ON	ON	ON	ON	ON	-
PURGE VALVE	R6	ON	-	-	-	-	-	-	-	-	-	-	-	-	-
NOTES:		TIMED SUMP FLUSH AND PURGE	INITIAL TIMED FILL 20 SECS. OR HIGH FLOAT SW OPENS	WAITING FOR CURTAIN SW.	CURT. SW. OPENS (MOMENT) ICE RELEASED	CURTAIN SW. CLOSES (MOMENT)	COOL THE EVAP PLATE AND FILL SUMP	5 MINUTE MIN. FREEZE TIME							

BIN FULL (CURTAIN OR STAT)

TRANSITION TO BIN FULL SHUTDOWN		HARVEST					BIN FULL	
		PURGE ON ENTERING HARVEST	TIMED FILL	WAIT FOR HARVEST	CURT SW/BIN STAT OPENS	BIN FULL / PUMP DOWN (REMOTES)	SYSTEM HOLD	
COMPONENTS	RELAY #							
FAN(S) W/FAN CYCLE	R1 (A/W)	-	-	-	-	-	-	-
LIQ. LINE VALVE	R1 (REM)	ON	ON	ON	ON	-	-	-
CONTACTOR/ COMPRESSOR/ REM. COND. FAN	R2	ON	ON	ON	ON	ON	ON	-
WATER PUMP	R3	ON	-	-	-	-	-	-
HOT GAS VALVE(S)	R4	ON	ON	ON	ON	ON	-	-
HARVEST ASSIST(S)	R5	ON	ON	-	-	-	-	-
WATER INLET VALVE	R6	ON	-	-	-	-	-	-
PURGE VALVE		ON	-	-	-	-	-	-
NOTES:		TIMED SUMP FLUSH AND PURGE - APPROX 7 SEC.	INITIAL TIMED FILL 20 SECS. OR TO HIGH FLOAT SW. OPEN	WAITING FOR CURTAIN SW. OR TIME	ICE HARVESTED - CURT/BIN STAT REMAIN OPEN	CURT OR BIN STAT REMAIN OPEN - UNIT SHUT DOWN (REMOTES PUMPDOWN APPROX 30 SEC)	BIN FULL WAIT FOR CURT/STAT TO CLOSE	

DIAGNOSTICS IN FREEZE CYCLE

The Diagnostic sequence is started by pressing both the Power and Clean buttons for 6 seconds.

DIAGNOSTICS		CONTROLLER STATES							
		AT START-UP		FREEZE					
		FROM OFF STATE POWER LED RED SOLID	PURGE	FILL	PRES. EQUAL.	PRESS. EQ. W/ COMPR.	FREEZE	ANTI-SLUSH	FREEZE
COMPONENTS	RELAY #								
FAN(S) W/FAN CYCLE	R1 (A/W)	-	-	-	-	ON	ON	ON	ON
LIQ. LINE VALVE	R1 (REM)	-	-	-	-	ON	ON	ON	ON
CONTACTOR/ COMPRESSOR/ REM. COND. FAN	R2	-	-	-	-	ON	ON	ON	ON
WATER PUMP	R3	-	ON	-	-	-	ON	-	ON
HOT GAS VALVE(S)	R4	-	-	-	ON	ON	-	-	-
HARVEST ASSIST(S)		-	-	-	-	-	-	-	-
WATER INLET VALVE	R5	-	-	ON	-	-	-	-	-
PURGE VALVE	R6	-	ON	-	-	-	-	-	-
NOTES:		VERIFY CONFIG 1 (PUMP DOWN FOR REM ONLY)	VERIFY EMPTY SUMP: LOW FLOAT SW: CLOSED	HI FLOAT SW: SATISFIED	HOT GAS OPEN APPROX. 5 SEC	CONTACTOR/COMPRESSOR STARTUP - HOT GAS CLOSES AFTER 5 SEC	5 MINUTE MIN. FREEZE TIME	AT SUMP TEMP 36F. TURN OFF WATER PUMP FOR 20 SEC	LOW FLOAT SW. CLOSE TO INITIATE HARVEST
		QUICK PRESS POWER AND CLEAN BUTTON ADVANCES TO NEXT STATE		QUICK PRESS POWER AND CLEAN BUTTON ADVANCES TO NEXT STATE					

DIAGNOSTICS IN HARVEST CYCLE

DIAGNOSTICS	CONTROLLER STATES						COMPLETE
	HARVEST						POWER LED RED SOLID
COMPONENTS	RELAY #	HOT GAS-HAA/ PURGE/ WATER INLET	HARVEST	CURT. SW. OPENS	HARVEST COMPLETE/ PUMP DOWN	DIAGNOSTICS COMPLETE	
FAN(S) W/FAN CYCLE	R1 (A/W)	-	-	-	-	-	-
LIQ. LINE VALVE	R1 (REM)	ON	ON	ON	-	-	-
CONTACTOR/ COMPRESSOR/ REM. COND. FAN	R2	ON	ON	ON	ON (REM ONLY)	-	-
WATER PUMP	R3	ON	-	-	-	-	-
HOT GAS VALVE(S)	R4	ON	ON	ON	-	-	-
HARVEST ASSIST(S)	R5	ON	-	-	-	-	-
WATER INLET VALVE	R6	ON	-	-	-	-	-
PURGE VALVE		TIMED RINSE AND PURGE APPROX 7 SEC	WAITING FOR CURTAIN SW. OR TIME	ICE RELEASED	CURT. CLOSES, VERIFY CONFIG 1 (PUMP DOWN FOR REM ONLY)	OFF STATE	OFF STATE
NOTES:	QUICK PRESS POWER AND CLEAN BUTTON ADVANCES TO NEXT STATE						OFF STATE

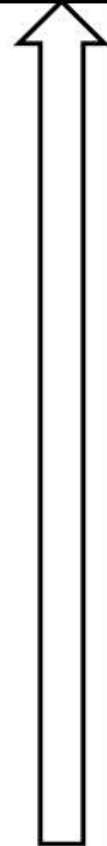

**Button Functions**

BUTTON FUNCTIONS			
INITIAL STATE	BUTTONS PRESS		FUNCTION/NEW STATE OR MODE
	POWER	CLEAN	
OFF - POWER LED SOLID RED	QUICK	-	FREEZE
	3 SEC	-	INDICATE CODE REVISION
	-	QUICK	CLEAN CYCLE
	3 SEC	3 SEC	CLEAR ERROR CODES AND RESET COUNTERS (Single BLUE and YELLOW light flash when reset)
	6 SEC	6 SEC	RUN DIAGNOSTICS PROGRAM
BIN FULL ON CURT/STAT - POWER LED SOLID BLUE	6 SEC	-	MACHINE OFF
HARVEST - POWER LED SOLID BLUE	QUICK	-	MANUAL HARVEST 2 - FINISHES THEN SHUTS OFF
	6 SEC	-	MACHINE OFF IMMEDIATELY
CLEAN IN PROCESS - POWER LED SOLID RED & CLEAN LED SLOW FLASH YELLOW	-	QUICK	ADVANCE TO PURGE AFTER MINIMUM OF 5 MIN OF WASH
	6 SEC	-	MACHINE OFF - CLEAN IN PROCESS
CLEAN COMPLETE - POWER LED SOLID RED & CLEAN LED SOLID YELLOW	-	QUICK	MACHINE OFF
	QUICK	-	MACHINE OFF
ANY STATE	6 SEC	-	MACHINE OFF
DIAGNOSTICS - POWER LED DOUBLE FLASH RED	QUICK	QUICK	ADVANCE TO NEXT STATE
	6 SEC	-	MACHINE OFF
	3 SEC	-	INDICATE CODE REVISION
ERROR 1 (MAX FREEZE/MAX HARVEST) - POWER LED QUICK FLASH RED	3 SEC	3 SEC	CLEAR ERROR CODES AND RESET COUNTERS (single BLUE and YELLOW light flash when reset)
	6 SEC	6 SEC	RUN DIAGNOSTICS PROGRAM
	3 SEC	-	INDICATE CODE REVISION
ERROR 3 (WATER SYS FAILURE) - POWER LED RED & CLEAN LED YELLOW QUICK FLASH	6 SEC	-	MACHINE OFF
	3 SEC	3 SEC	CLEAR ERROR CODES AND RESET COUNTERS Single BLUE/YELLOW flash when reset)
	6 SEC	6 SEC	RUN DIAGNOSTICS PROGRAM
	3 SEC	-	INDICATE CODE REVISION
RINSE- POWER LED SLOW FLASH BLUE	QUICK	-	ADVANCE FREEZE
HARVEST VERIFICATION - POWER LED SLOW FLASH BLUE	QUICK	-	NO ACTION (CURTAIN SWITCH OPEN/CLOSE TO ADVANCE)
DEFAULT HARVEST - POWER LED SLOW FLASH BLUE	QUICK	-	NO ACTION (CURTAIN SWITCH OPEN/CLOSE TO ADVANCE)
COMPRESSOR DELAY (3 MINUTES) - POWER LED SLOW FLASH BLUE	QUICK	-	NO ACTION (COMPRESSOR WILL NOT RESTART FOR 3 MINUTES)
MANUAL HARVEST 1 - POWER LED QUICK FLASH BLUE	QUICK	-	CANCELS MANUAL HARVEST 1 - CONTINUES CYCLE
MANUAL HARVEST 2 - POWER LED QUICK FLASH BLUE	QUICK	-	CANCELS MANUAL HARVEST 2 - COMPLETES HARVEST AND CONTINUES OPERATION

## **Sump**

The Sump holds the potable water for the Freeze Cycle. It is located under the Evaporator and accessible from the front of the unit. The Sump must be removed to access the Water Pump and the Float Switch Housing.



## **22" and 30 " Units Sump Removal**

First remove the Splash Curtain and Splash Guard.



Disconnect Water Pump Tube as shown above and tuck backside of tube into the Sump.

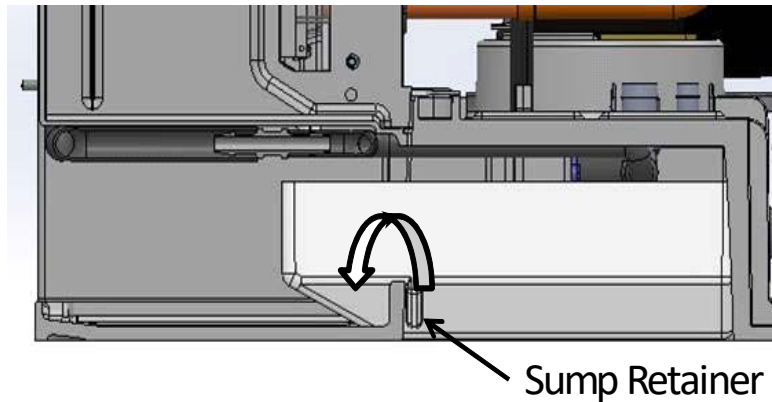

Lift front of Sump and pull forward to clear the Sump Retainers from the frame.



With the Support Tabs now clear of the frame, allow the back of the Sump to fall clear of the frame.

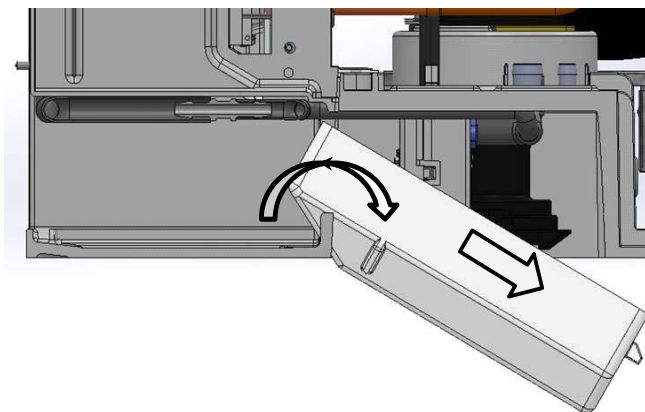

Again lift the front of the Sump and push towards the back and down until Sump is clear of the frame. Turn the Sump sideways and remove through the ice drop zone.

To re-install, reverse process making sure to tuck Water Pump Tube into Sump as lift Sump into place.

### **48" Unit Sump Removal**

Removal of the splash curtain and splash guard is the same as the 22" and 30" units. You will do this twice as there are two of each for the 48" units. The Water Pump Tube will need to be disconnected also and this is the same process as in the 22" and 30" units as well. Tuck the backside of the tube into the sump to keep it out of the way during sump removal.

Starting on the right side, lift up and pull forward to move the sump over the right side retention feature.



Next, lower the right side of the sump into the bin and release the left side of the sump.



After the sump is released from the retention features, lower the entire sump into the bin and rotate it so it will come out the front of the unit.



Slowly remove the sump from the bin so as to not hit and damage other components.



Installation of the sump is the reverse of removal. Ensure the left side is seated properly, before attempting to press the right side into place. Improper placement of the left side can lead to damage of the retention features during installation.

## High and Low Float Switches and Housing

### Float Housing Assembly

The Float Switch Housing Assembly contains the High and Low Float Switches along with the Sump Thermistor. See below for function of each. See also Sequence of Operation pg. 9.

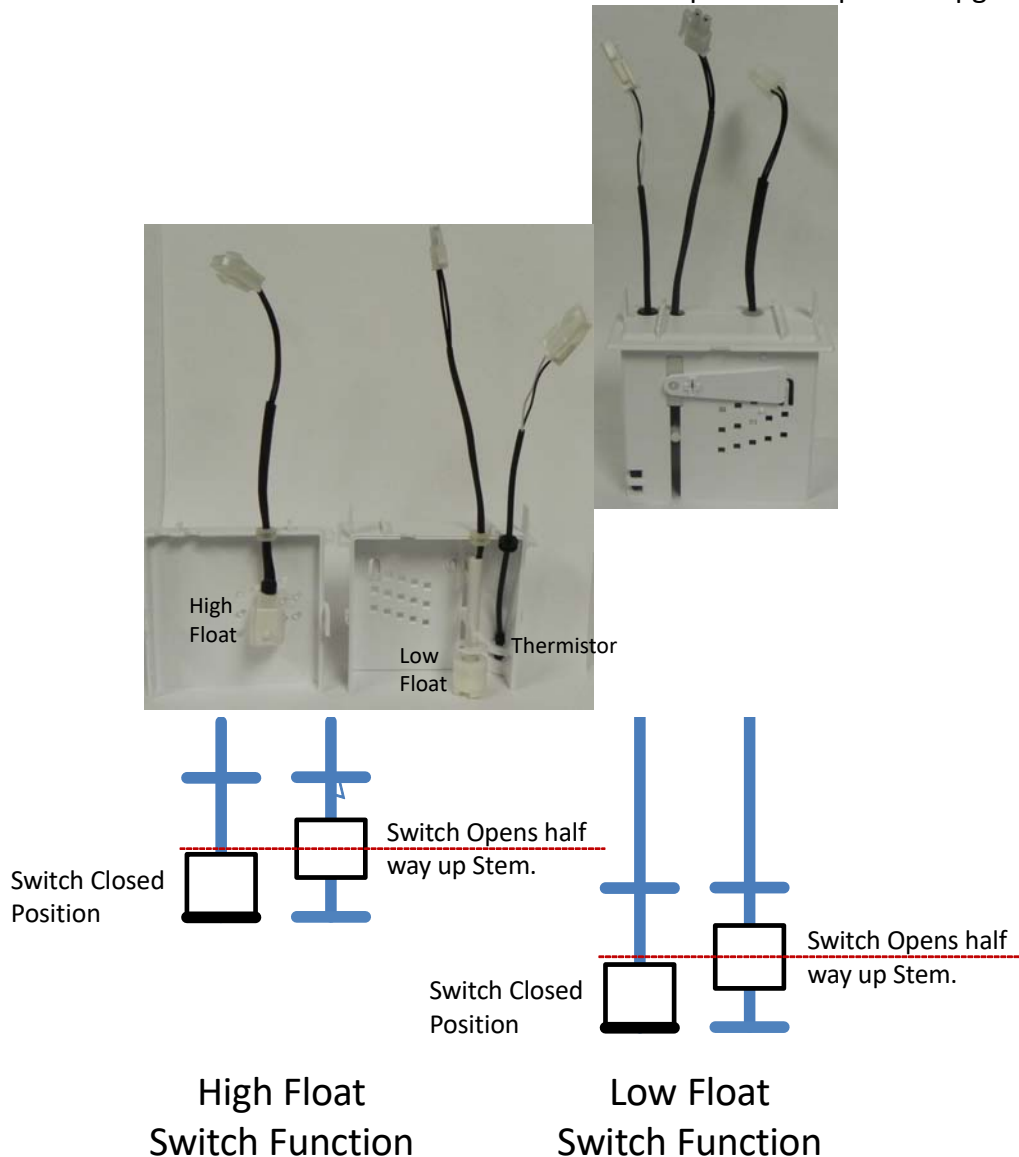

### High and Low Float Switch Operation

The High Float Switch is used to control the water level for ice making, cleaning and sanitizing. The Float will rise with the water level, opening the contact of the switch and signal the Board to close the Water Inlet Valve. The LED associated with the High Float switch will be ON when the contacts of the switch are closed, and will turn OFF when the contacts open. The Low Float Switch is used to determine when the unit is ready to go into the Harvest Cycle during ice production and when the Sump has been emptied of cleaner or sanitizer during the Cleaning Cycle. The LED associated with the Low Float Switch operates the same as the LED for the High Float Switch. The LED will ILLUMINATE when the contact of the float are closed and will turn OFF



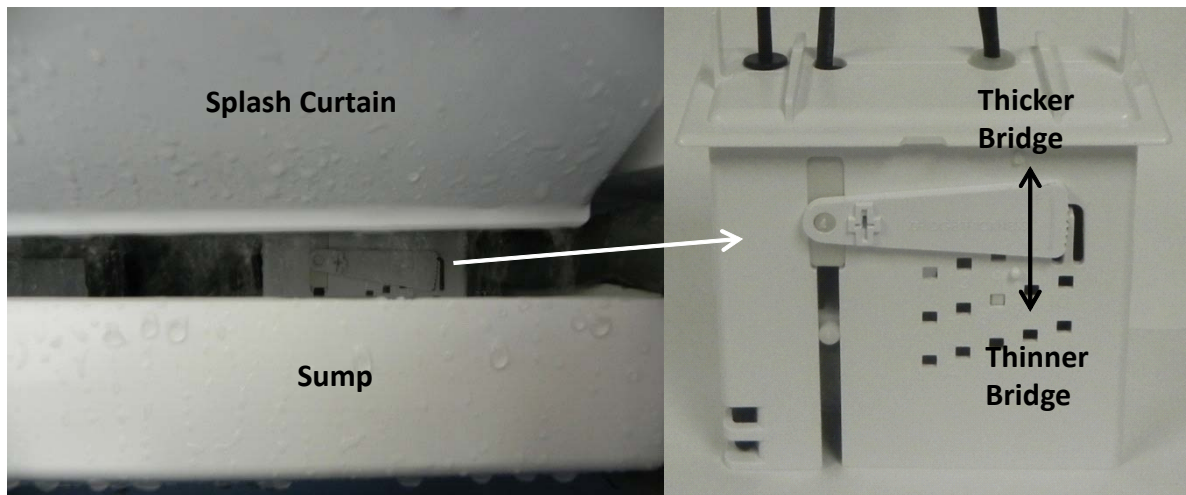

The Bridge Thickness on units under 400# production should be  $3/16$ " while units over 400# production should be  $1/8$ " thick when measured across the middle of the plate. Minor Adjustments can be made to the bridge thickness by moving the Water Level Adjustment Arm of the Float Housing up for a thicker bridge or down for a thinner bridge. This adjustment can be made at any time during the freeze or defrost cycle and the results verified on the following cycle.



**Water Pump Removal**

The “foot” of the Water Pump points towards the right front corner of the unit. Grasp the foot and turn counter clockwise. When the foot points towards the right rear corner, you will feel the weight of the pump as the collar clears the base connections. Lower the Water Pump and disconnect. Re-install the Water Pump by first making the electrical connection, the push Pump up pointing the Foot at the right rear corner and turn clockwise to secure.

### **Water Distribution Tube**

The Water Distribution Tube has an inner tube and an outer tube. The water enters through the inner tube and sprays the water up into the outer tube relieving the pressure on the water. Gravity takes over and the water runs out the outer tube holes pointed down. The water runs smoothly and evenly over the Evaporator.



### **Removal and Disassembly**

Disconnect Water Pump Tube from Water Distribution Tube.

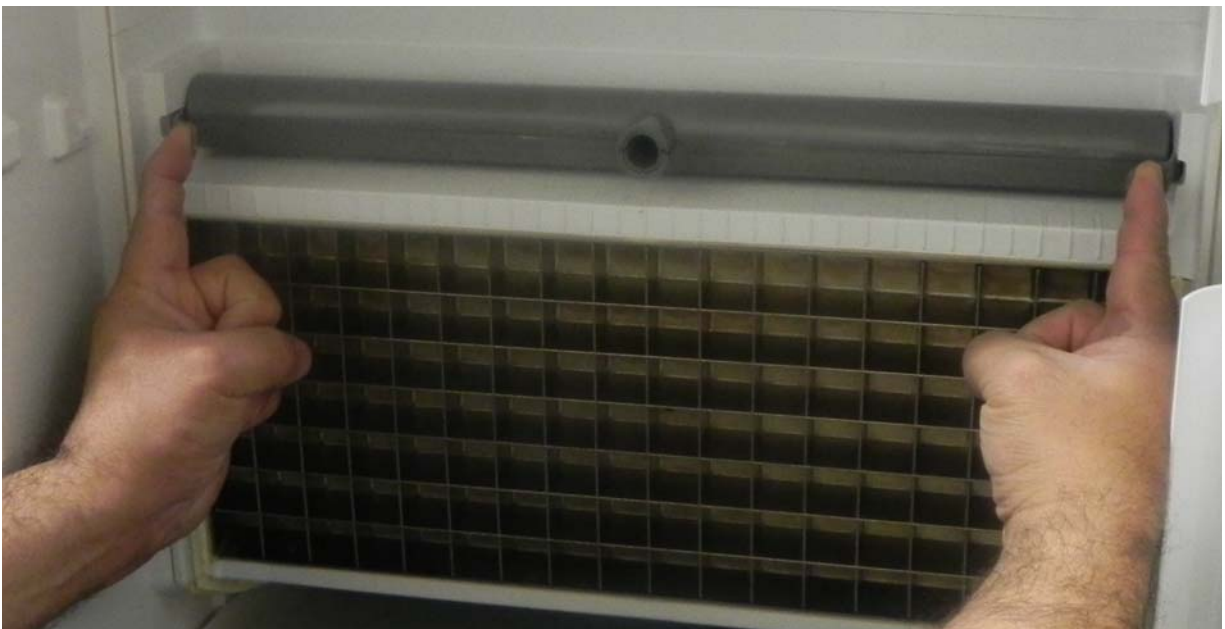

Gentle squeeze the tabs inward on the Water Distribution Tube and forward towards the front of the unit.

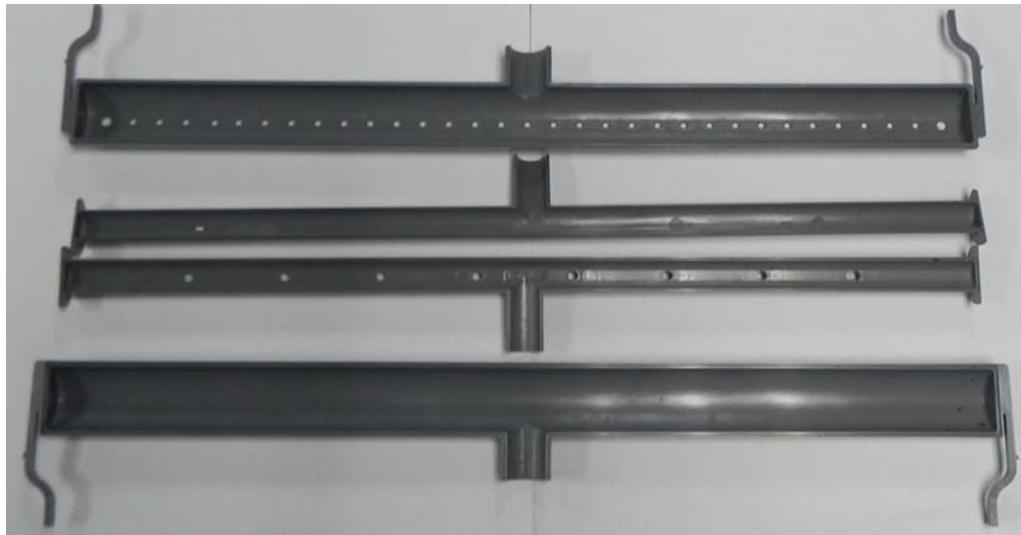

The Water Distribution Tube comes apart easily. It should be taken apart and cleaned regularly along with the rest of the unit. The pieces are Pokeyoke, meaning it only goes back together one way.

## Water Inlet Valve

### Operation

Relay 4 on the Board (LED ON) energizes the Valve first on initial start-up to fill the Sump until the contacts of the High Float Switch open, indicating a proper amount of water for ice making. The purpose is to verify water supply before starting the unit. After the initial cycle is complete, the Valve will be energized during the Harvest Cycle and if needed, re-energized during the Pre-Chill to complete filling the Sump (See Sequence of Operation pg. 9). In either case, Relay 4 will be illuminated when Water Inlet Valve is energized. During the Cleaning and Sanitizing Cycle the Water Inlet Valve will be energized several times during the rinse and purge portion of the cycle (see Cleaning Instructions pg. 56).



### Troubleshooting

The maximum fill time allowed to open the contacts of the High Float Switch is 5 minutes. If Relay 4 is illuminated and the Water Inlet Valve doesn't open, verify water supply to the unit, then check for line voltage between the Tan and Blue wires on the Molex. If line voltage is not present, the issue is the Board. If line voltage is present, check for line voltage at the Water Inlet Valve coil. If no line voltage is present, the issue is the wiring or connectors. If line voltage is present, check resistance of coil. No resistance = open coil, replace Valve. If coil checks out, verify Water Inlet Valve for cleanliness and clean or replace as needed. Also verify incoming water supply and for plugged filters.

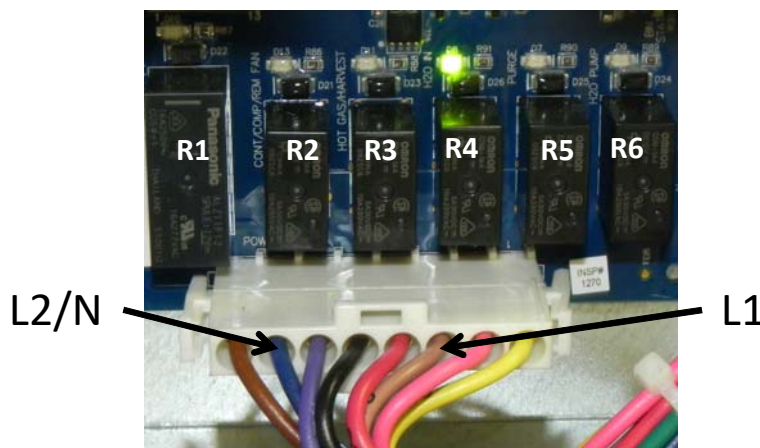

Voltage can also be verified at the connector at the coil of the Water Inlet Valve.

## Purge Valve

### Operation

The Purge Valve is located in the back of the Evaporator. The Valve should open when energized by Relay 5 on the Board (LED ON) during the Harvest Cycle to help empty the mineral laden water (see Sequence of Operation pg. 9) and during the Cleaning/Sanitizing Cycle (see Cleaning Instructions pg. 56).



### Troubleshooting

The Purge Valve is located in the back of the Evaporator. The Valve should open when energized by Relay 5 on the Board (LED ON) during the Harvest Cycle to help empty the mineral laden water and during the Cleaning/Sanitizing Cycle. If Purge Valve fails to open with Relay 5 LED illuminated, unplug Connector at coil of Valve and check for line voltage. If none is found, check output voltage at Molex at Board between Pink and Blue wires. If no voltage is found, the Board is the issue. If output voltage is found, wiring between Molex and connector at Valve is the issue.

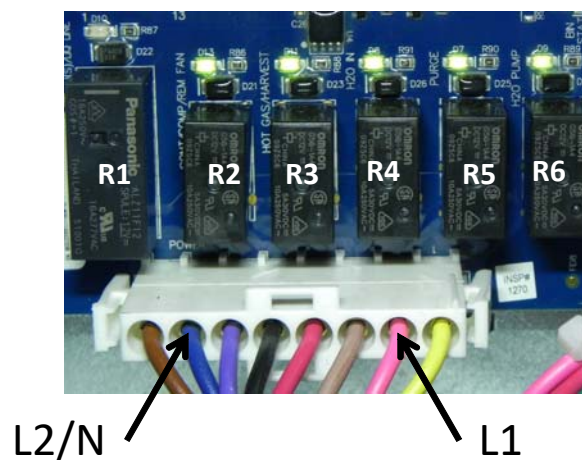

Voltage can also be verified at the connector at the coil on the Purge Valve.

## Harvest Assist Assembly/Hot Gas Valve

### Operation

The Harvest Assist Assembly is mounted to the back of the Evaporator Assembly. It is energized by Relay 3 along with the Hot Gas Valve. As the unit enters the Harvest Cycle, Relay 3 will illuminate indicating voltage is being sent to the Harvest Assist Assembly and the probe will be pushed forward to meet the ice slab. As the Evaporator warms, the Probe on the Harvest Assist will move forward to help release the ice from the plate. As the ice slab falls it will open the Magnetic Curtain Switch contacts. Relay 3 will then be de-energized and the Harvest Assist will automatically return to the starting position.

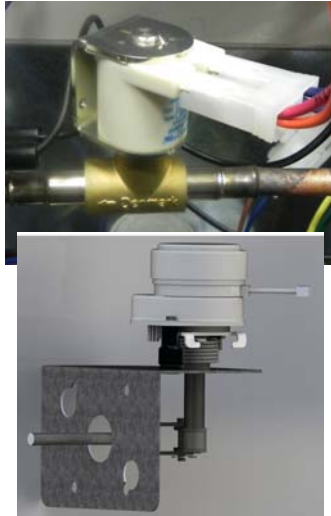

### Troubleshooting

The Harvest Assist Assembly is energized with the Hot Gas Valve throughout the Defrost Cycle by Relay 3. To quickly verify operation, put the unit into Diagnostics program by pressing both the Power and Wash buttons for 6 seconds, then quick press BOTH the Power and Clean buttons until the Harvest Cycle is initiated (R2 - R6 LED's above component Molex should illuminate). Verify LED for Relay 3 is illuminated and check voltage between the Blue and Red wires at Molex. If no voltage is present, the Board or Molex may be the issue. If voltage is verified, Check for voltage at the wiring connector for the Harvest Assist. If voltage is verified and the probe is not pushed forward, the issue is the Harvest Assist.

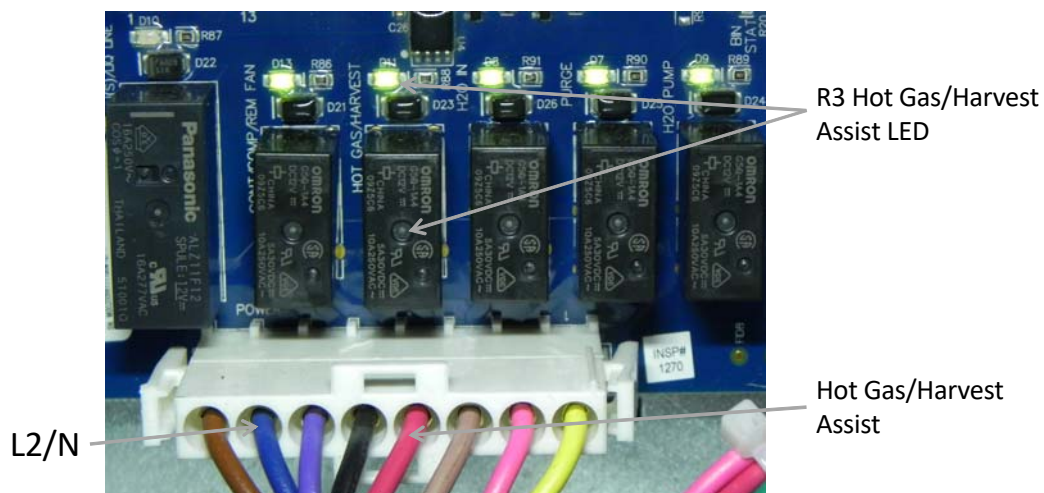

## Magnetic Curtain Switch

The Magnetic Curtain Switch is a proximity switch that closes the contacts when the Splash Curtain closes. LED's on the Board indicate a closed switch when illuminated.

**Note:** In 48" units there is a curtain magnet and proximity switch for both plates, on the left and right sides of the unit.

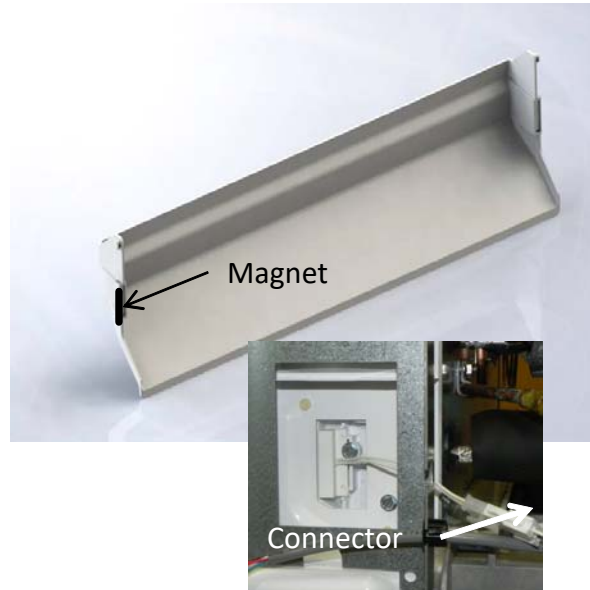

## Troubleshooting

Should the LED's on the Board be off when the Splash Curtain is closed, first verify the magnet is in place on the Splash Curtain and the Wiring Harness is properly connected at the Switch and at the Board. If all is verified, use a different magnet against the switch. If it still will not close, replace the Magnetic Curtain Switch.

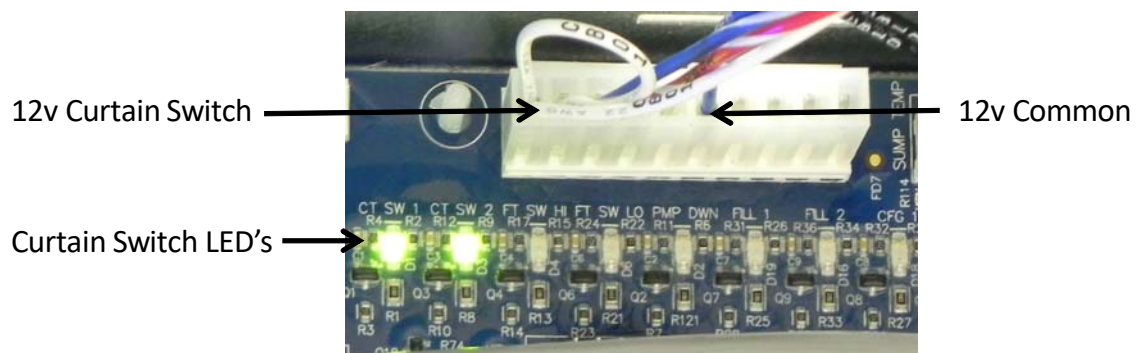

## **High Pressure Cut-out and Fan Cycle Switch**

### **High Pressure Cut-out (left)**

The High Pressure Cut-out is set to open at 450 psig and de-energizes the Contactor as a safety on the unit.

### **Fan Cycle Control (right)**

The Fan Cycle Control helps maintain head pressure in cooler ambient temps. The control closes at 250 psig, energizing the Fan Motor and opens at 200 psig.



## **Troubleshooting**

### **High Pressure Cut-out**

The High Pressure Cut-out opens at 450 psig to de-energize the Contactor and shutdown the Compressor. The control re-closes at 350 psig. Should the control open during the Freeze Cycle, the unit may go into Error 1 state, indicating the Freeze Cycle has run for more than 1 hour. To quickly check the unit operating pressure, run a Diagnostic Cycle with stub gauges on the unit. A dirty or blocked Condenser, failed Fan Cycle Control, failed Fan Motor, high side restriction or refrigerant over charge can be the cause.

### **Fan Cycling Control**

The Fan Cycle Control closes on pressure rise at 250 psig and opens on pressure drop at 200 psig to maintain head pressure in cooler ambient conditions. The cut-in and cut-out should never be erratic. Should the contacts of the control close and/or open outside these parameters, the control should be replaced.

## Fan Motor

### Operation

The Fan Motor (Self Contained Air Cooled Units) is Mounted to the Fan Shroud covering the Condenser at the rear of the unit. It is energized by Relay 1 and controlled by the Fan Cycling Switch. The Switch should close at 250 psi of head pressure and power the Motor. The Fan Cycle Switch should open at 200 psi of head and the Fan Motor will de-energize.



### Troubleshooting

When the Fan Motor is inoperable or cycling outside of the operational parameters, first verify the LED for Relay 1 is illuminated, indicating the Board is calling for the Fan Motor to run. If the unit is in the Freeze Cycle and the LED is not illuminated, the issue may be the board. If it is illuminated, check voltage between the Violet and Blue with a meter. Line voltage should be shown. If inappropriate voltage is shown, verify Molex connection at the Board and correct if loose. If still no voltage out, replace the Board. If voltage is verified, check contacts of Fan Cycle Switch for voltage then check contacts which should be closed at pressures above 250 psi. If open in these conditions, jump control. If Fan Motor comes on, issue is Fan Cycling Control. If Motor does not come on, check connection at Motor. If verified, the issue is the Fan Motor.

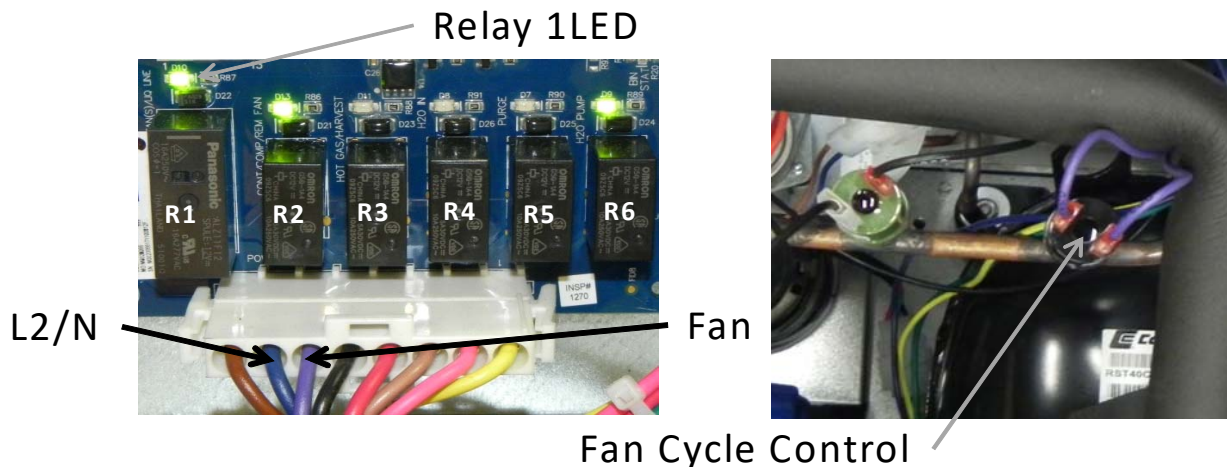

## **Evaporator**

The nickel plated Evaporator Assembly has a copper core to assure good heat transfer. Water is pumped gently over the Evaporator during the freeze cycle for even ice formation.



### **Evaporator Operation**

The Evaporator should be fully flooded with refrigerant for most of the freeze cycle to assure even ice formation. The serpentine on the back of the Evaporator starts at the bottom right corner of the plate (viewed from the front). The refrigerant lines run horizontally back and forth to the middle of the plate then rise along the left hand side to the top. The lines continue “serpentine” downward to the middle of the plate and exit the Evaporator.

### **Troubleshooting**

The Evaporator should always have a nickel appearance. Should the Evaporator have a “rust” color after a thorough cleaning, the plating may have come off and a replacement may be required. A dull “rainbow shimmer” may indicate an improper cleaner was used on the unit. Only approved Nickel Safe ice machine cleaner should be used.

An improper ice formation can be caused by a water or refrigeration issue.

A dirty water system can cause poor water flow over the Evaporator resulting in improper ice formation. See pg 56 for Cleaning Instructions.

A refrigeration issue such as a low charge or restricted TXV could show on the Evaporator as ice forming on the bottom of the plate with thin to no ice forming on the top half. Verify refrigeration pressures on the Technical Specifications chart on pg. 60.

Should the ice slab resist coming off the plate, examine the Evaporator for lose of plating, pitting, mineral accumulation and/or loose horizontal dividers. Should any of the horizontal dividers separate from the base, replacement of the Evaporator is recommended.

Single Evaporator Plate Units

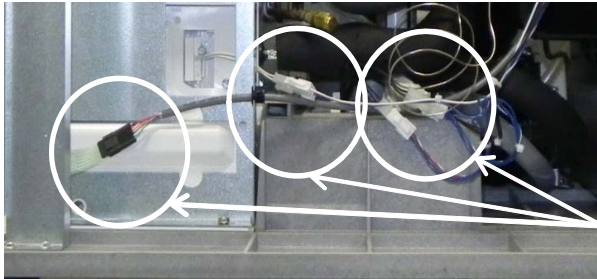

While recovering the refrigerant from the unit, disconnect High and Low Float Switches, Thermistor, Curtain Switch and Push Pad ribbon and move the wiring clear of the area.

Connectors

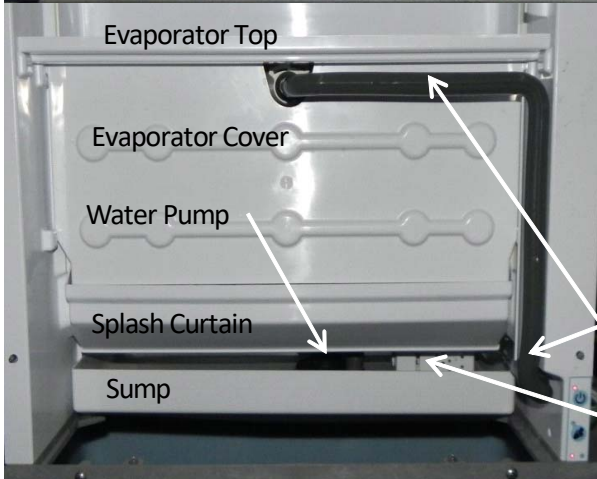

Remove the Splash Curtain, Evaporator Cover, Top Evaporator Cover, Water Distribution Tube, Water Pump Tube and its connector, Sump, Water Pump, and Float Switch Housing Assembly.

Water Pump Tube & Connector

Float Switch Housing



Harvest Assist Assembly



Purge Valve

On the rear of the Evaporator Assembly, disconnect Harvest Assist Assembly, Purge Valve and Purge Tube and remove from unit.



Cut Zip Ties

Remove 1/4" screws



Once unit is recovered, unsolder Evaporator refrigerant lines

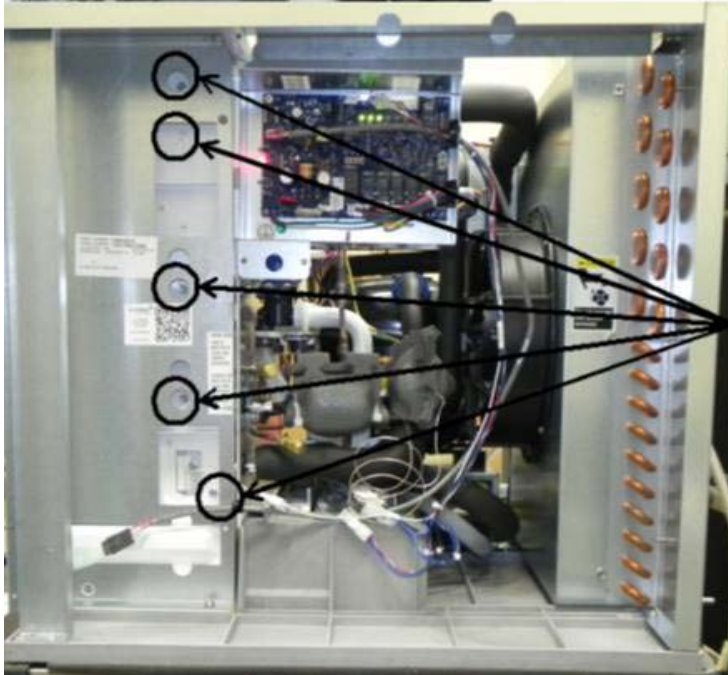

Remove 5) 1/4" screws securing Evaporator to surround on right hand side of unit.

Remove the right hand side wall and discard. You will replace it with a new one that is provided in the kit.



Remove 2) 1/4" screws where frame meets The base on the left hand side of the unit.

The new evaporator comes with two new side wall pieces. For a single evaporator unit you will only use the exterior right side wall that comes in the kit to replace the existing right side wall. This will allow the new evaporator to be installed without interfering with the plastics. It has cut outs to allow for the new tubing routing. For reference, see the image labeled "Exterior Right Wall" in the dual evaporator replacement section for correct part identification.



Surround

Pull bottom of frame out to clear left hand surround.

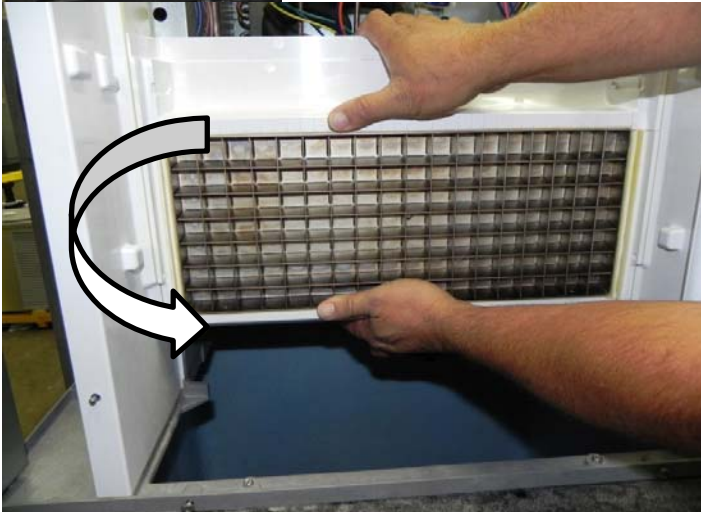

Grasp and remove Evaporator freeing the Left Hand side first. The Left Hand Surround will come out with the Evaporator; the Right Hand surround will be left in place. Once the Evaporator is out, separate the surround from the Evaporator by removing the five – 1/4" Screws on the Left Hand side of the Evaporator. Remove Curtain Switch on Right Hand side of Evaporator and place on new Evaporator and mount Left Hand Side surround on new Evaporator.



Remove old silicone from base where shown in picture. Run a 3/8" bead of silicone included with Evaporator kit to replace existing where surround and Evaporator meet on the base.

Install Evaporator and reverse procedure for installation of components. Be sure to replace the Drier on all open system repairs.

When reinstalling screws into the base be sure to not exceed a torque of 30in-lb to avoid stripping them.

48in Dual Plate Evaporator Units

Recover the refrigerant from the unit. During the recovery disconnect curtain switch and push pad ribbon and move the wiring clear of the area. Remove the two mounting screws in the base of the unit near the curtain switch. Depending on the one being replaced remove the left or right side screws.

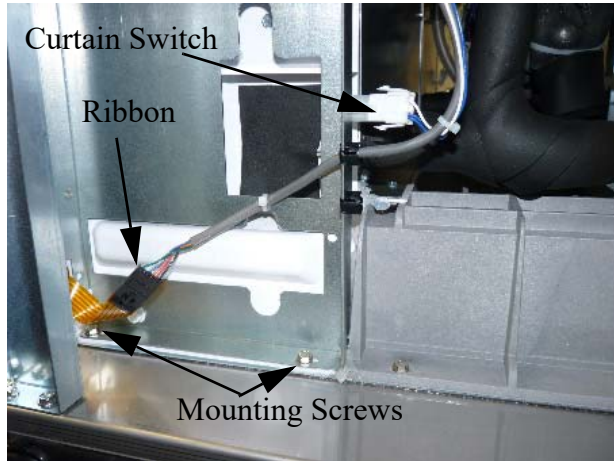

Right Side of Unit

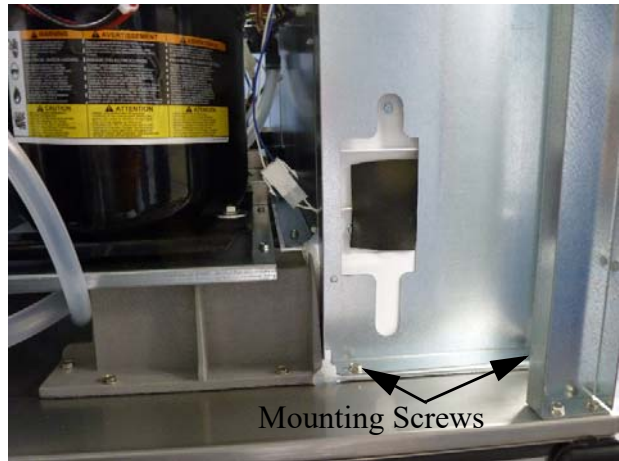

Left Side of Unit

Remove the splash curtain, evaporator cover, top evaporator cover, water distribution tube, water pump tube and its connector, sump, water pump, and float switch housing assembly.

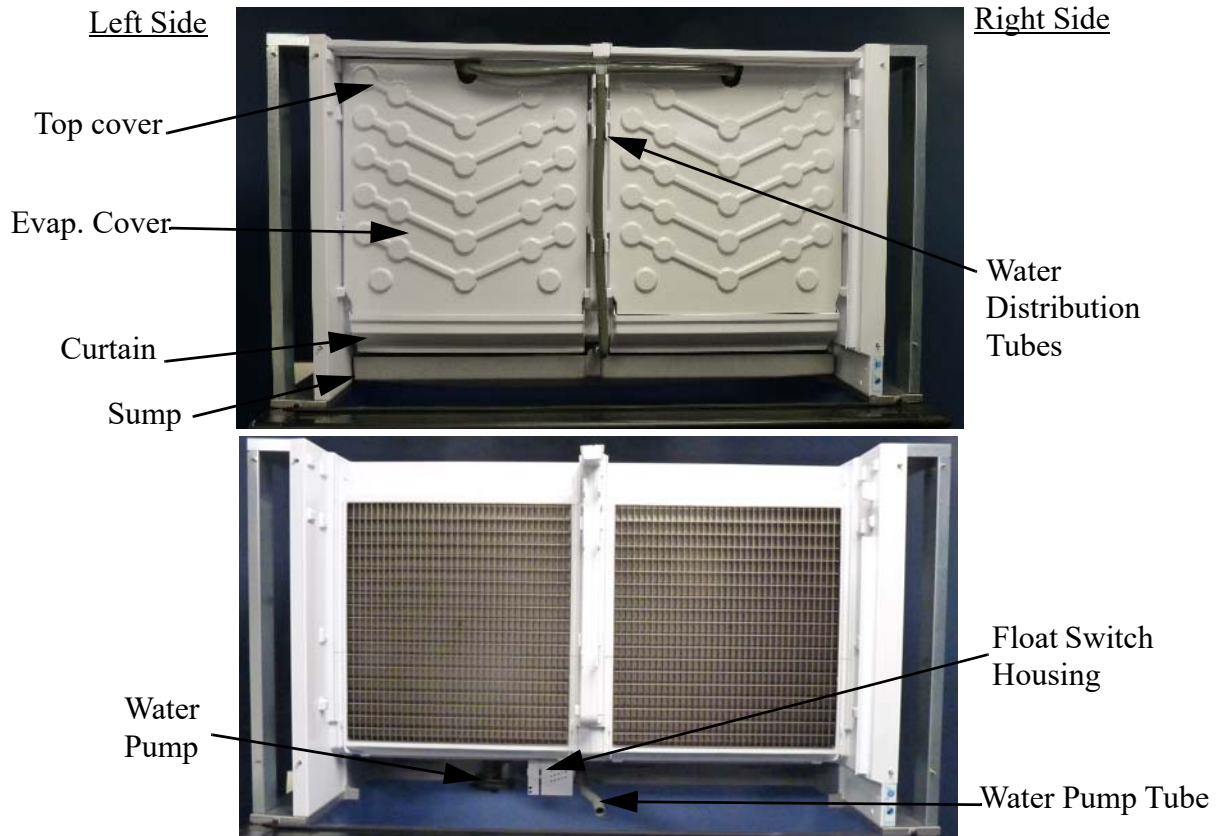

On the rear of the evaporator assembly, disconnect harvest assist assembly, purge valve and purge tube and remove from the unit. Note there are two harvest assist, one for each plate. Make sure you disconnect the proper one.

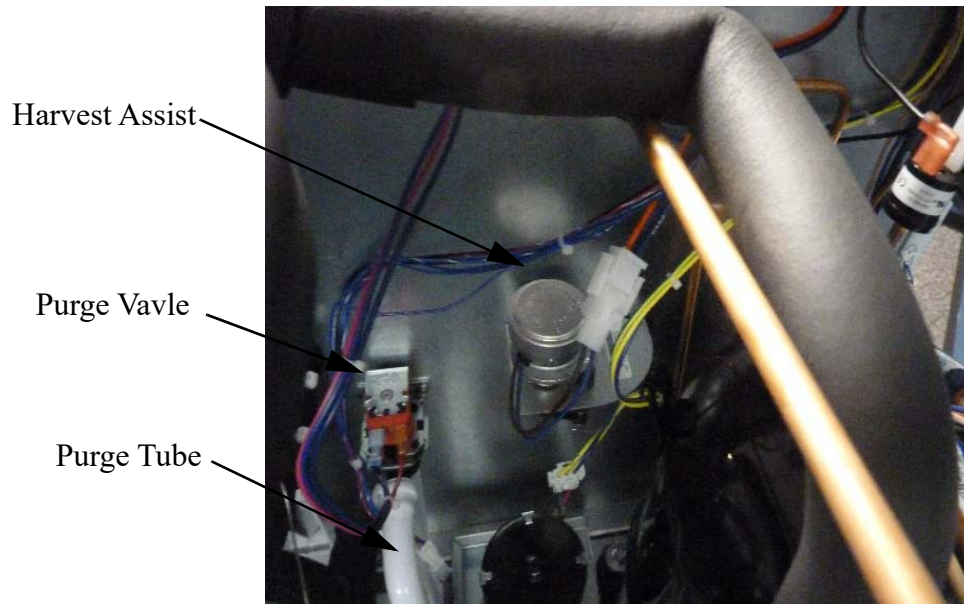

Once all the refrigerant is recovered. Remove the foam insulation from the evaporator plate tubing and Un-braze the evaporator tubes from the system so the plate is disconnected from the tubing system.

Remove the three ¼" screws along the back side of the evaporator holding it to the base in the machine compartment.

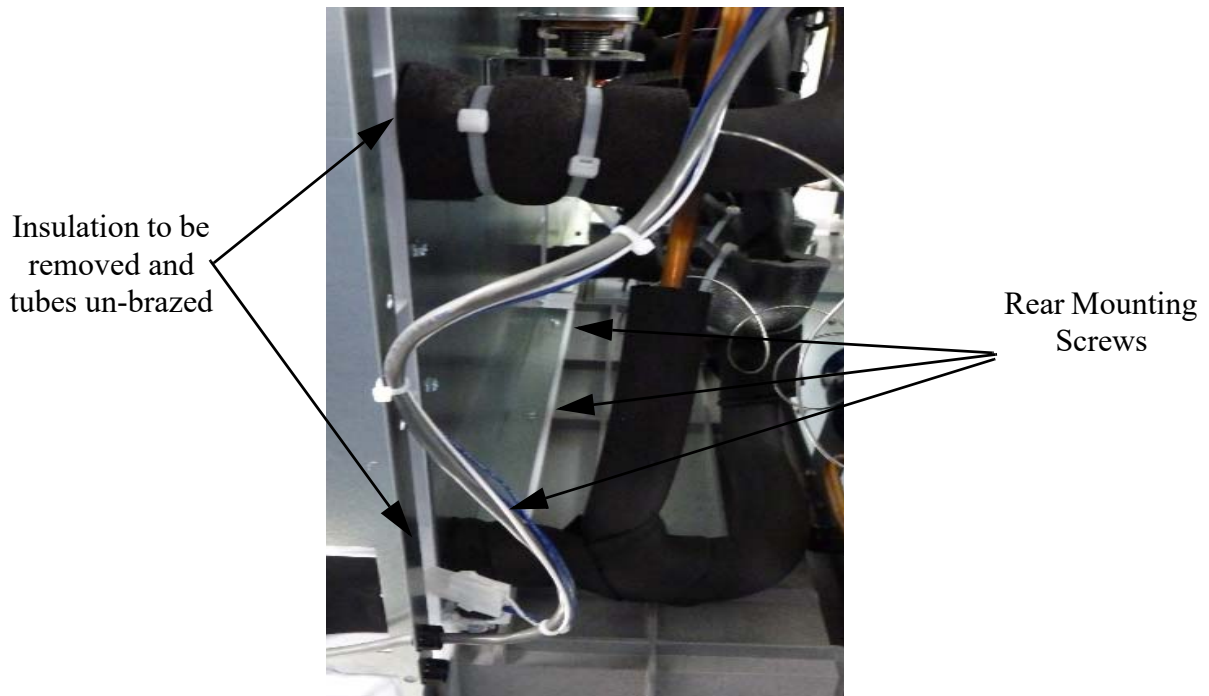

Drill out the rivets that are holding the top middle cross beam to have access to the two top rear mounting screws. Remove the corresponding screw to the evaporator you are working on.

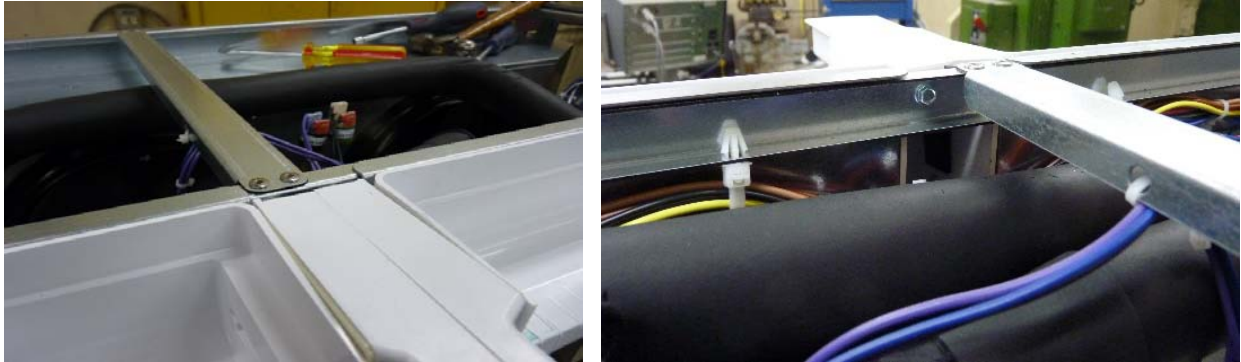

With all the retaining screws out, and everything disconnected you should now be able to rotate the plate out of position for replacement with the new evaporator.



The new evaporator comes with two new side wall pieces. If replacing the left evaporator plate, you will use the right interior wall. If replacing the right evaporator plate you will use the right side wall. These new pieces have cut outs to accept the updated evaporator plate.



Interior Right Wall



Exterior Right Wall

There are five screws holding both side walls on to the evaporator assembly. Remove them and the side wall from the old assembly and reuse the screws to mount the new side walls to the new evaporator plate assemblies.

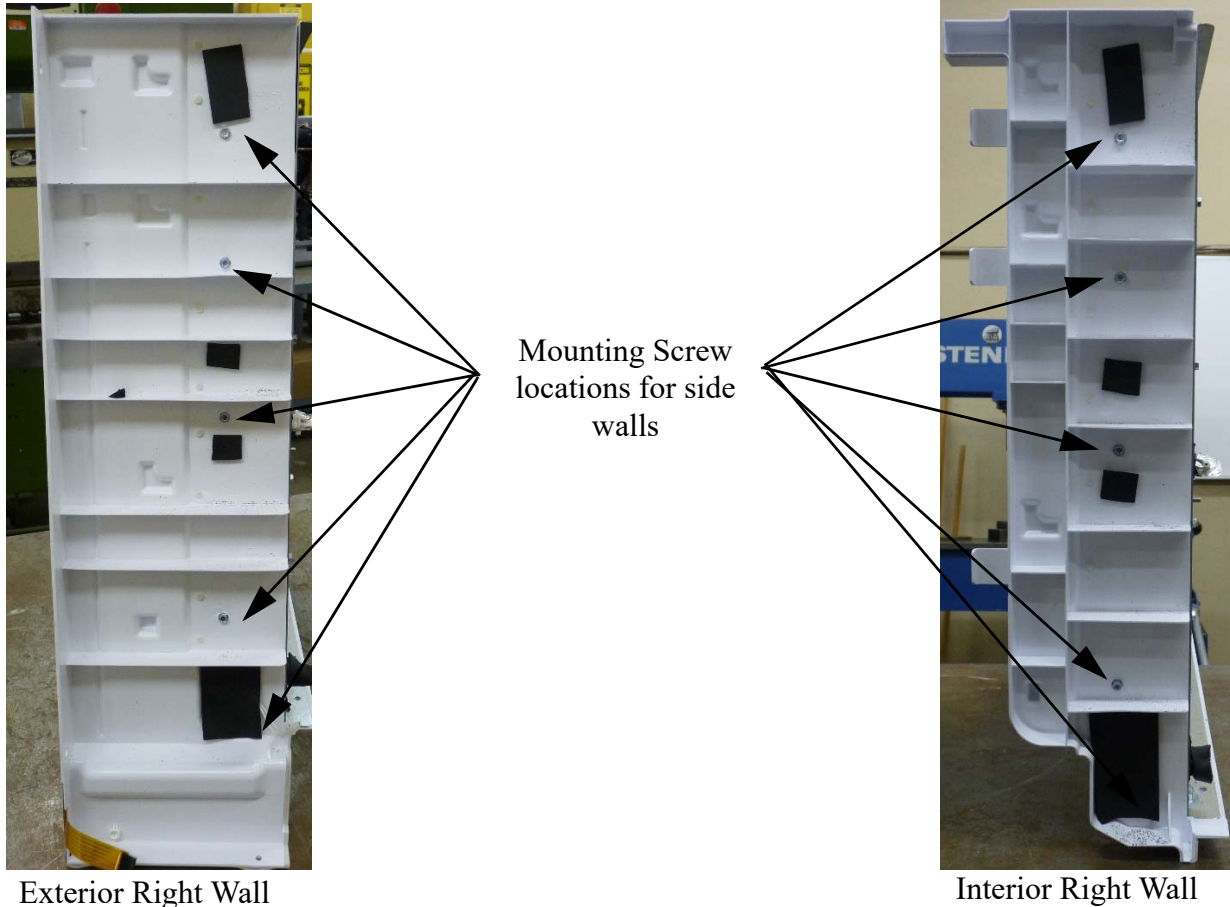

The left side walls from the old evaporators will be reused. Remove them from the old assemblies and reattach them to the new evaporator. Reuse the screws from the old assemblies. Remove the old silicone on the base where it interfaces with the evaporator. Add a new 3/8" bead of silicone to the corners and flat face of the base before reinstalling new evaporator.

Once you have the side walls attached to the new evaporator. Reinstall the assembly in the reverse order. When reinstalling screws into the base be sure to not exceed a torque of 30in-lb to avoid striping the base. Be sure to replace the filter dryer as well since it is an open system repair.

## **High Temp Safety**

The High Temp Safety is a bi-metal thermostat strapped to the line at the outlet of the Hot Gas Valve. Should the Hot Gas Valve stick open and the refrigerant line reach 180 degrees F., the High Temp Safety would open, dropping power to the Contactor and shut down the Compressor. When the line temperature drops below 120 degrees F., the contacts of the Safety will close, allowing power to the Contactor.

**Note:** 48" units have two high temp safety switches connected in series, should either hot gas circuit trigger a switch, it will shut down the compressor.

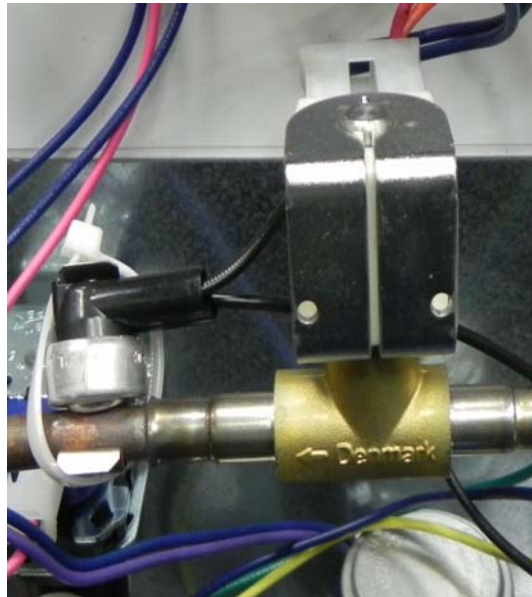

## **Troubleshooting**

Should the Compressor not run with the R2 relay LED illuminated, verify if High Pressure Cutout is closed and Contactor coil is good. The discharge line from the Hot Gas Valve should be cool to the touch during a freeze cycle. With a line temperature below 120 degrees F. (confirming hot gas valve is closed), the contacts in the High Temp Safety should be closed. Disconnect both leads of the High Temp Safety and check for continuity. If open with a cool line, the safety will need to be replaced.

## **Refrigeration Section**

The Refrigeration Section on a CIM Cuber contains the Compressor, Thermostatic Expansion Valve, Hot Gas Valve and Condenser. Remote systems also utilize a Mixing Valve (LAC), Liquid Line Solenoid and Receiver.

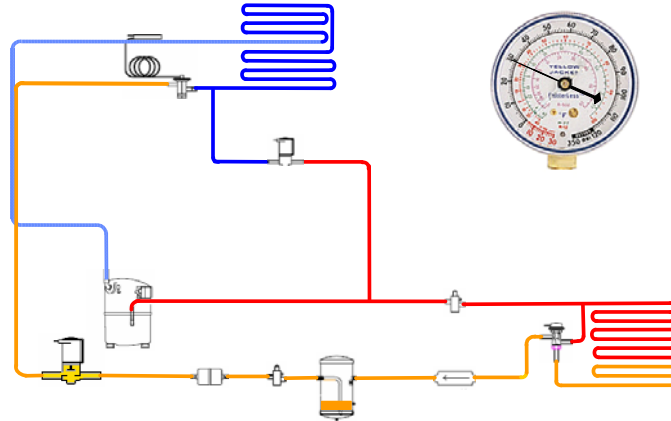

### **Refrigeration Section Operation**

The Compressor drives the refrigeration system. Ice-O-Matic uses a Thermostatic Expansion Valve to control refrigerant flow through the Evaporator.

### **Troubleshooting - System**

When troubleshooting the refrigeration system, always use stub gauges to limit the amount of refrigerant lost during connecting and disconnecting.

Always verify the refrigeration systems operating pressures when diagnosing any refrigeration component. The Compressor should pull within 10% of the RLA when measured 5 minutes into the Freeze Cycle and greater than 70% of RLA during the Freeze Cycle to be considered efficient.

### **Thermostatic Expansion Valve**

The Thermostatic Expansion Valve meters refrigerant through the Evaporator.

### **Troubleshooting - Expansion Valve**

First verify proper system pressures and charge. Verify the TXV bulb is securely mounted at 7 degrees off vertical and well insulated. Generally a low suction pressure with a normal head pressure will show as poor ice formation top to bottom on the Evaporator and indicate a low side restriction such as at the TXV. Should suction run high or not drop, verify bulb connection to suction line and look for sweating or frosting on the dome of the Compressor indicating TXV is stuck open.

**Hot Gas Valve**

The Hot Gas Solenoid Valve opens to provide gas to the Evaporator during the Harvest Cycle.

**Troubleshooting - Hot Gas Valve**

Should the valve not open at the initiation of the Harvest Cycle (R3 LED ON), verify voltage at the coil of the solenoid. If no voltage is present, verify Molex is properly connected at Board and Voltage is present at Molex. If Voltage is present at coil, verify resistance through coil. If coil shows open, replace the coil. If coil checks out, place magnetic donut on top of coil. If valve will not open, replace Hot Gas Valve body. Should suction pressure run high, check temperature of the inlet and outlet line of the Hot Gas Valve. Should be greater than 10 degree F. different. If less than 10 degrees F., the Valve is leaking and should be replaced. (See also pg.44.)

**Liquid Line Solenoid**

The Liquid Line Solenoid opens to allow refrigerant to flow from the Receiver on Remote Systems. It is energized by R1 along with the Remote Fan Motors. Diagnosis of Liquid Line Solenoid is much the same as the Hot Gas Solenoid Valve (see above.)

**Mixing Valve**

The 220 psig. Mixing Valve (or LAC) Is used to maintain head pressure in low ambient .

**Troubleshooting - Mixing Valve**

In lower ambients, the Mixing Valve should be bypassing the Condenser to maintain head pressure. The inlet and outlet lines at the Condenser would be the same temp. in bypass mode. In warmer ambients the Mixing Valve is pushing refrigerant to the Condenser Coil and there would be approx. 20 degree F. temperature difference. A low charge would be identified by hot inlet and outlet lines at the Condenser and a hot Receiver. Always verify charge before condemning the Mixing Valve.

## **General Maintenance**

### **⚠ WARNING**

**Electrical shock and/or injury from moving parts inside this machine can cause serious injury. Disconnect electrical supply to machine prior to performing any adjustments or repairs.**

**Failure to perform the required maintenance at the frequency specified will void warranty coverage in the event of a related failure.**

### **General Maintenance Procedure**

To insure economical, trouble free operation of your machine; it is recommended that the following maintenance be performed every 6 months.

1. Clean the ice-making section per the instructions below. Cleaning should be performed a minimum of every 6 months. Local water conditions may require that cleaning be performed more often.
2. Check ice bridge thickness. See page 10 for proper thickness and adjustment procedure.
3. Check water level in Sump. See page 10 for proper water level and adjustment procedure.
4. Clean the condenser (air-cooled machines) to ensure unobstructed air flow.
5. Check for leaks of any kind: water, refrigerant, oil, etc.
6. Check the bin control switch (if applicable) for proper adjustment.
7. Check the Water Regulating Valve (water cooled machine) for proper adjustment by measuring the discharge pressure which should be adjusted to maintain 250 psi (17.01 bar/ 1.723 MPa). Adjust the water regulating valve as required. Water exiting the condenser should be between 100°F (38°C) and 110°F (43°C).
8. Check all electrical connections.
9. Oil the fan motor if the motor has an oil fitting. (Self contained air-cooled models only)
10. Check the water filter (if applicable) and replace if dirty or restricted
11. Inspect the evaporator water distribution tube to insure even distribution of water across the face of the evaporator.
12. Clean Remote Condenser if applicable.

## **Cleaning and Sanitizing**

### **Cleaning Instruction for Ice-O-Matic CIM Series Ice Machines**

**Note: Proper cleaning of an ice machine requires two parts: descaling and sanitizing.**

**Descaling** should be scheduled at a minimum of twice per year but no more than once per month.

Descaling dissolves the mineral deposits on the evaporator and other surfaces. It removes scale, calcium, lime scale and other mineral buildup. Ice-O-Matic requires a “nickel-safe” cleaner such as Nu-Calgon Nickel-Safe Ice Machine Cleaner or equivalent diluted per manufacturer’s instructions.

**Sanitizing** should be performed after each descaling but no more than once per month.

Sanitizing disinfects the machine and removes microbial growth including mold and slime. Ice-O-Matic requires a “nickel-safe” sanitizer such as Nu-Calgon IMS-III or equivalent diluted per manufacturer’s instructions.

Please refer to [www.icematic.com](http://www.icematic.com) for approved chemical formulations and proper pH balance.

**CAUTION: Do not mix cleaner (descaler) and sanitizer together.**

**Eye protection is recommended when handling descaler or sanitizer.**

**Wear protective rubber gloves when handling descaler or sanitizer.**

**Note: Electrical power will be ON when performing the following cleaning instructions.**

1. Remove all ice from storage means to prevent any contamination of ice in storage.
2. Remove the front panel of the ice machine by loosening the two front panel screws with a Phillips head screwdriver. Lift panel to remove.
3. Press and hold the POWER button for 3 seconds to initiate a harvest cycle (blue light will begin to flash for Manual Harvest mode). This ensures there is no ice on the plate and the water is emptied from the sump.

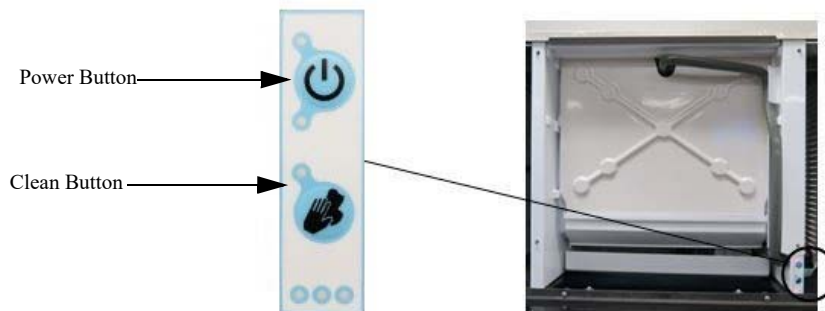

4. Once the ice machine has completed its harvest cycle, the POWER light will go to solid red (OFF mode).
5. Remove the upper evaporator cover and leave the lower curtain.

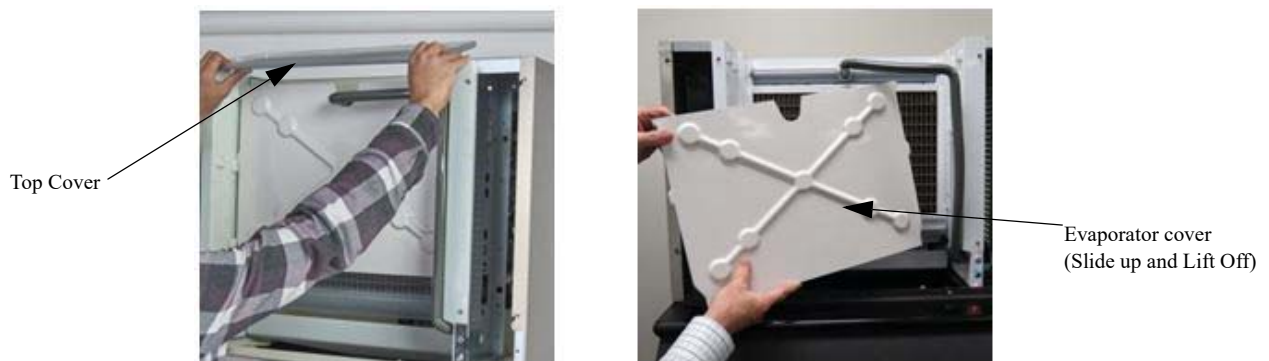

6. Quick press the CLEAN button to start the process. Ice machine will show a solid red and flashing yellow light during the cleaning cycle.
7. The machine will first verify that the sump is empty with the pump ON and the purge valve energized.
8. When the sump is mostly empty, the machine will begin to fill the sump (about 30 seconds to a minute).
9. The pump turns ON when the water fill reaches the proper fill level. Measure the appropriate amount of descaler according to the machine size and sump volume from [chart below](#). Carefully pour the descaler into the sump using the lower curtain to prevent splash. Replace upper evaporator cover.

Model	Sump Size (volume) Gallons (in liters)	Example: Nu-Calgon Nickel-Safe Ice Machine Cleaner Descaler Concentration Ratio 5 fl.oz. per 1 gal. of water (39 mL per 1 Liter of water)	Example Nu-Calgon IMS-III Sanitizer Concentration Ratio 1.6 fl. oz. per 1 gal. of water (12.5 mL per 1 Liter of water)
CIM0320/0330	.9 (3.4)	Add 4.5 fl. oz. (133mL)	Add 1.5 fl. oz. (44mL)
CIM0430/0520/0530/0630	1.2 (4.5)	Add 6 fl. oz. (177mL)	Add 2 fl. oz. (59mL)
CIM0820/0830/1120/1130	1.1 (4.2)	Add 5.5 fl. oz. (164mL)	Add 1.8 fl. oz. (53mL)
CIM1440/1540/1840/2040	1.8 (6.8)	Add 9.0 fl. oz. (265mL)	Add 2.9 fl. oz. (85mL)



10. The machine will remain in the WASH cycle for 15 minutes.
11. After WASH time, the machine will PURGE and re-fill with the water pump ON.
12. The machine will RINSE (less than one minute) then repeat PURGE/FILL/RINSE multiple times.
13. The machine will end the cleaning cycle with a mostly empty sump and a solid red and yellow light.
14. Quick press the CLEAN button to return to OFF mode.
15. Remove the upper evaporator cover and lower evaporator curtain. Using a solution with the proper concentration of cleaner (descaler or sanitizer), wipe down with a clean soft cloth the evaporator, water spillway, water distributor, upper evaporator cover, lower evaporator curtain and all splash surfaces. Verify that all residue and residual minerals have been removed.
16. If a full clean of water components is required, this can be done by referring to the service manual for water system component breakdown. This is recommended to be done by a qualified service agent.
17. Re-assemble all ice machine water system components in reverse order.
18. Sanitizing the ice machine is recommended after descaling. Repeat the process with sanitizer at correct ratio.
19. It is recommended to clean (descale and sanitize) the storage means after cleaning the ice machine.
20. Quick press the POWER button to return the ice machine to the ice making cycle.
21. Replace the front panel and tighten the two panel screws with a Phillips screwdriver.

## Cabinet Care

### Chemicals for Descaling and Sanitizing

It is important to use solutions that do not harm the ice machine. Never use cleaning or sanitizing solutions that contain Nitric Acid, Sulfuric Acid, Hydrochloric Acid, Carboric Acid, Acetic Acid, diluted Acetic Acid or non-food-grade vinegar (concentration of acetic acid greater than 6% and does not contain enzymes created in processing) or any chlorine-based solution such as bleach, chlorine dioxide or any type of salts such as potassium chloride (potassium salts) or sodium chloride. Check the label or the manufacturer's Material Safety Data Sheet (MSDS) to be sure. These chemicals can attack the surface of the evaporator as well as other metal components causing corrosion and flaking.

Please refer to [www.iceomatic.com](http://www.iceomatic.com) for approved chemical formulations and proper pH balance.

### Cleaning Stainless Steel and Aluminum

Commercial grades of stainless steel and aluminum are susceptible to rusting or corrosion if not properly maintained. It is important that you properly care for the stainless steel and aluminum surfaces of your ice machine and bin to avoid the possibility of rust or corrosion.

Use the following recommended guidelines for keeping your machine looking like new:

1. **Clean the stainless steel and aluminum thoroughly once a week.** Clean frequently to avoid build-up of hard, stubborn stains. Hard water stains left to sit can weaken the metals corrosion resistance and lead to rust or corrosion. Use a nonabrasive cloth or sponge, working with, not across, the grain.
2. **Do not use abrasive tools to clean the metal surface.** Do not use steel wool, abrasive sponge pads, wire brushes or scrapers to clean the metal.
3. **Do not use cleaners that use chlorine or chlorides.** Do not use chlorine bleach products to clean the metal surfaces. Chlorides break down the metals protective layer.
4. **Rinse with clean water.** If chlorinated cleansers are used, you must thoroughly rinse the surface with clean water and wipe dry immediately.
5. **Use the right cleaning agent.** The table below lists the recommended cleaning agents for common metal cleaning problems.

Cleaning Activity	Cleaning Agent	Method of Application
Routine Cleaning	Mild dish soap, ammonia, glass cleaner, or mild detergent with water. Household kitchen cleaning chemicals approved for metal surfaces.	Apply with clean cloth or sponge. Rinse with clean water and wipe dry.
Removing grease or fatty acids	Oven cleaners	Apply generously; allow to stand for 15-20 minutes. Rinse with clean water. Repeat as required.
Removing hard water spots and scale	Vinegar	Swab or wipe with clean cloth. Rinse with water and wipe dry.

## Winterizing Procedures

**IMPORTANT: Whenever the ice machine is taken out of operation during the winter months, the procedure below must be performed. Failure to do so may cause serious damage and will void all warranties.**

1. Turn off water to machine.
2. Make sure all ice is off of the evaporator(s). If ice is being made, initiate harvest by pressing the Power Button for approximately 3 seconds. The unit will shut off automatically following the harvest.
3. Disconnect the tubing between the water pump discharge and water distribution tube and drain any water.
4. On water cooled machines, hold the water regulating valve open by prying upward on the water valve spring with a screwdriver while using compressed air to blow all the water out of the condenser.

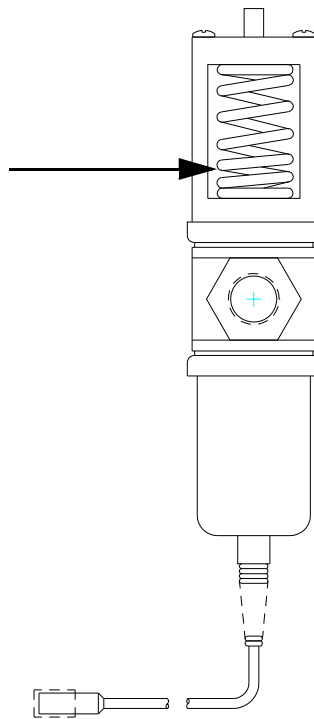

5. Remove all of the ice in the storage bin and discard.

**Technical Specifications**

Model	Voltage/Hz/ Phase	Approx. suction Press	Approx. Head Press	Avg. Batch Half/Full	Approx. Cycle Time 90/70 in Min.	Avg. Water Usage per 100 lbs. Produced in Gallons		Min Circuit Amps	Max Fuse size	kWH Used	Comp. LRA	Comp. RLA	Ref. Type	Charge in ounces
						Potable	Water Cond.							
CIM0320A	115/60/1	50-30	175-400	3.025/3.375	18-23	20.0		11.0	15	6.69	50.0	8.1	R-404a	20
CIM0320W	115/60/1	50-30	250	3.025/3.375	16-21	19.6	179	10.7	15	5.19	50.0	8.1	R-404a	13
CIM0325A	220-240/50/1	50-30	175-400	3.025/3.375	19-24	22.0		6.9	16	7.32	29.5	5.1	R-404a	22
CIM0325W	220-240/50/1	50-30	250	3.025/3.375	16-21	20.0	187.5	6.8	16	5.53	29.5	5.1	R-404a	13
CIM0326A	208-230/60/1	50-30	175-400	3.025/3.375	18-23	24.0		6.5	15	6.8	26.5	4.6	R-404a	22
CIM0330A	115/60/1	50-30	175-400	3.025/3.375	18-23	20.0		11.0	15	6.69	50.0	8.1	R-404a	20
CIM0330W	115/60/1	50-30	250	3.025/3.375	16-21	19.6	179	10.7	15	5.19	50.0	8.1	R-404a	13
CIM0335A	220-240/50/1	50-30	175-400	3.025/3.375	19-24	22.0		6.9	16	7.32	29.5	5.1	R-404a	22
CIM0430A	115/60/1	50-30	175-400	5.025/5.65	22-26	19.8		11.0	15	5.43	50.0	8.1	R-404a	24
CIM0430W	115/60/1	50-30	250	5.025/5.65	19-22	17.8	169	10.7	15	4.75	50.0	8.1	R-404a	14
CIM0435A	220-240/50/1	50-30	175-400	5.025/5.65	20-24	20.0		8.7	16	5.97	37.0	6.3	R-404a	24
CIM0436A	115/60/1	50-30	175-400	5.025/5.65	17-20	18.0		6.3	15	5.46	26.5	4.6	R-404a	24
CIM0436W	115/60/1	50-30	250	5.025/5.65	20-24	17.7	185	6.1	15	4.37	26.5	4.6	R-404a	14
CIM0520A	115/60/1	50-30	175-400	5.025/5.65	18-22	19.9		17.8	30	5.87	70.0	13.5	R-404a	20
CIM0520W	115/60/1	50-30	250	5.025/5.65	15-18	20.0	181	17.4	30	4.7	70.0	13.5	R-404a	14
CIM0525A	220-240/50/1	50-30	175-400	5.025/5.65	18-21	20.0		11.2	16	6.11	38.0	8.5	R-404a	22
CIM0525W	220-240/50/1	50-30	250	5.025/5.65	15-18	19.5	190	11.0	16	5.00	38.0	8.5	R-404a	14
CIM0526A	208-230/60/1	50-30	175-400	5.025/5.65	17-21	20.0		8.2	15	5.02	33.7	6.1	R-404a	22
CIM0530A	115/60/1	50-30	175-400	5.025/5.65	18-22	19.9		17.8	30	5.87	70.0	13.5	R-404a	20
CIM0530W	115/60/1	50-30	250	5.025/5.65	15-18	20.0	181	17.4	30	4.7	70.0	13.5	R-404a	14
CIM0530R	115/60/1	50-30	220-400	5.025/5.65	17-21	19.6		20.1	30	6.21	70.0	13.5	R-404a	132
CIM0535A	220-240/50/1	50-30	175-400	5.025/5.65	18-21	20.0		11.2	16	6.11	38.0	8.5	R-404a	22
CIM0535W	220-240/50/1	50-30	250	5.025/5.65	16-19	19.5	190	11.0	16	5	38.0	8.5	R-404a	13
CIM0535R	220-240/50/1	50-30	220-400	5.025/5.65	17-20	20.0		12.0	20	6.31	38.0	8.5	R-404a	132
CIM0635A	220-240/50/1	50-30	175-400	5.025/5.65	16-19	20.0		8.1	16	5.72	37.0	5.8	R-404a	22
CIM0636A	208-230/60/1	50-30	175-400	5.025/5.65	16-19	18.6		9.2	15	5.63	46.0	6.9	R-404a	20
CIM0636W	208-230/60/1	50-30	250	5.025/5.65	14-16	19.2	180	9.0	15	4.27	46.0	6.9	R-404a	14
CIM0636R	208-230/60/1	50-30	220-400	5.025/5.65	14-16	19.0		10.0	15	5.29	46.0	6.9	R-404a	132
CIM0825A	220-240/50/1	50-30	175-400	7.15/8.10	17-21	18.0		13.3	20	4.73	55.0	9.7	R-404a	40
CIM0825R	220-240/50/1	50-30	220-400	7.15/8.10	15-18	18.0		13.7	20	4.38	55.0	9.7	R-404a	176

Model	Voltage/Hz/ Phase	Approx. suction Press	Approx. Head Press	Avg. Batch Half/Full	Approx Cycle Time 90/70in Minutes	Avg. Water Usage per 100 lbs. Produced in Gallons		Min Circuit Amp.	Max Fuse size	kWH Used	Comp. LRA	Comp. RLA	Ref.T ype	Charge in ounces
						Potable	Water Cond.							
CIM0826A	208-230/60/1	50-30	175-400	7.15/8.10	17-20	19.0		13.4	20	5.0	56.0	9.8	R-404a	40
CIM0826W	208-230/60/1	50-30	250	7.15/8.10	17-20	19.0	140	12.8	20	4.2	56.0	9.8	R-404a	30
CIM0826R	208-230/60/1	50-30	220-400	7.15/8.10	16-19	19.0		13.8	20	4.9	56.0	9.8	R-404a	176
CIM0835A	220-240/50/1	50-30	175-400	7.15/8.10	16-19	18.0		13.3	20	4.73	55.0	9.7	R-404a	40
CIM0835GA	220-240/50/1	50-30	175-400	8.6	17-20	18.0		15.2	20	5.7	58.0	11.2	R-404a	38
CIM0835W	220-240/50/1	50-30	250	7.15/8.10	16-19	18.0	110	12.7	20	3.96	55.0	9.7	R-404a	28
CIM0835R	220-240/50/1	50-30	220-400	7.15/8.10	16-19	18.0		13.7	20	4.38	55.0	9.7	R-404a	176
CIM0836A	208-230/60/1	50-30	175-400	7.15/8.10	16-19	19.0		13.4	20	5	56.0	9.8	R-404a	40
CIM0836W	208-230/60/1	50-30	250	7.15/8.10	16-19	19.0	140	12.8	20	4.2	56.0	9.8	R-404a	30
CIM0836R	208-230/60/1	50-30	220-400	7.15/8.10	16-19	19.0		13.8	20	4.9	56.0	9.8	R-404a	176
CIM0836GA	208-230/60/1	50-30	175-400	8.6	17-20	19.0		13.9	20	5.4	78.0	10.2	R-404a	38
CIM1125A	220-240/50/1	50-30	175-400	7.15/8.10	16-19	18.0		15.2	25	5.2	58.0	11.2	R-404a	36
CIM1125R	220-240/50/1	50-30	220-400	7.15/8.10	11-15	18.0		15.6	25	4.6	58.0	11.2	R-404a	176
CIM1126A	208-230/60/1	50-30	175-400	7.15/8.10	11-15	19.0		13.9	20	5.1	78.0	10.2	R-404a	40
CIM1126W	208-230/60/1	50-30	250	7.15/8.10	11-15	19.0	140	13.3	20	4.1	78.0	10.2	R-404a	32
CIM1126R	208-230/60/1	50-30	220-400	7.15/8.10	11-15	19.0		14.3	20	5.1	78.0	10.2	R-404a	176
CIM1135A	220-240/50/1	50-30	175-400	7.15/8.10	11-15	18.0		15.2	25	5.2	58.0	11.2	R-404a	36
CIM1135W	220-240/50/1	50-30	250	7.15/8.10	11-15	18.0	110	14.6	25	4.2	58.0	11.2	R-404a	32
CIM1135R	220-240/50/1	50-30	220-400	7.15/8.10	11-15	18.0		15.6	25	4.6	58.0	11.2	R-404a	176
CIM1136A	208-230/60/1	50-30	175-400	7.15/8.10	11-15	19.0		13.9	20	5.1	78.0	10.2	R-404a	40
CIM1136W	208-230/60/1	50-30	250	7.15/8.10	11-15	19.0	140	13.3	20	4.1	78.0	10.2	R-404a	32
CIM1136R	208-230/60/1	50-30	220-400	7.15/8.10	11-15	19.0		14.3	20	5.1	78.0	10.2	R-404a	176
CIM1137A	208-230/60/3	50-30	175-400	7.15/8.10	11-15	19.0		9.5	15	5.1	51.0	6.7	R-404a	40
CIM1137W	208-230/60/3	50-30	250	7.15/8.10	11-15	19.0	140	8.9	15	4.1	51.0	6.7	R-404a	32
CIM1137R	208-230/60/3	50-30	220-400	7.15/8.10	11-15	19.0		9.9	15	4.9	51.0	6.7	R-404a	176
CIM1446A	208-230/60/1	50-30	175-400	14.3/16.2	17-20	14.4		19.2	30	4.4	73.0	13.9	R-404a	58
CIM1446W	208-230/60/1	50-30	250	14.3/16.2	16-19	14.7	103.9	18.9	30	3.72	82.0	14.4	R-404a	30
CIM1446R	208-230/60/1	50-30	220-400	14.3/16.2	17-20	15.0		19.9	30	4.35	82.0	14.4	R-404a	250
CIM1447A	208-230/60/3	50-30	175-400	14.3/16.2	16-19	14.4		13.7	20	4.4	66.0	9.5	R-404a	58
CIM1447W	208-230/60/3	50-30	250	14.3/16.2	16-19	14.7	103.9	12.6	20	3.72	65.5	9.4	R-404a	30
CIM1447R	208-230/60/3	50-30	220-400	14.3/16.2	15-18	15.0		13.6	20	4.35	65.5	9.4	R-404a	250

Model	Voltage/Hz/ Phase	Approx. suction Press	Approx. Head Press	Avg. Batch Half/Full	Approx Cycle Time 90/70in Minutes	Avg. Water Usage per 100 lbs. Produced in Gallons		Min Circuit Amp.	Max Fuse size	kWH Used	Comp. LRA	Comp. RLA	Ref.T ype	Charge in ounces
						Potable	Water Cond.							
CIM1545A	220-240/50/1	50-30	175-400	14.3/16.2	17-20	14.8		18.8	30	4.49	64.0	13.6	R-404a	58
CIM1545W	220-240/50/1	50-30	250	14.3/16.2	16-19	14.3	101.7	17.9	30	3.67	64.0	13.6	R-404a	30
CIM1545R	220-240/50/1	50-30	220-400	14.3/16.2	15-18	14.6		19.4	30	4.03	64.0	13.6	R-404a	250
CIM1845A	220-240/50/1	50-30	175-400	14.3/16.2	17-20	14.0		21.0	30	4.57	75.9	15.4	R-404a	54
CIM1845W	220-240/50/1	50-30	250	14.3/16.2	15-18	14.5	109.3	18.1	25	3.67	75.9	13.8	R-404a	30
CIM1845R	220-240/50/1	50-30	220-400	14.3/16.2	15-18	14.4		21.6	35	4.09	75.9	15.4	R-404a	292
CIM2046A	208-230/60/1	50-30	175-400	14.3/16.2	16-19	14.9		25.0	40	4.62	96.0	18.6	R-404a	58
CIM2046W	208-230/60/1	50-30	250	14.3/16.2	15-18	14.8	134.2	24.1	40	3.52	96.0	18.6	R-404a	42
CIM2046R	208-230/60/1	50-30	220-400	14.3/16.2	15-18	14.9		25.6	40	4.31	96.0	18.6	R-404a	292
CIM2047W	208-230/60/3	50-30	250	14.3/16.2	17-20	14.8	134.2	15.1	25	3.52	75.0	11.4	R-404a	42
CIM2047R	208-230/60/3	50-30	220-400	14.3/16.2	17-20	14.9		16.6	25	4.31	75.0	11.4	R-404a	292

# Wiring Diagram

## CIM 115V and 230V, 60Hz, SINGLE PHASE, SINGLE EVAPORATOR AIR AND WATER COOLED UNITS

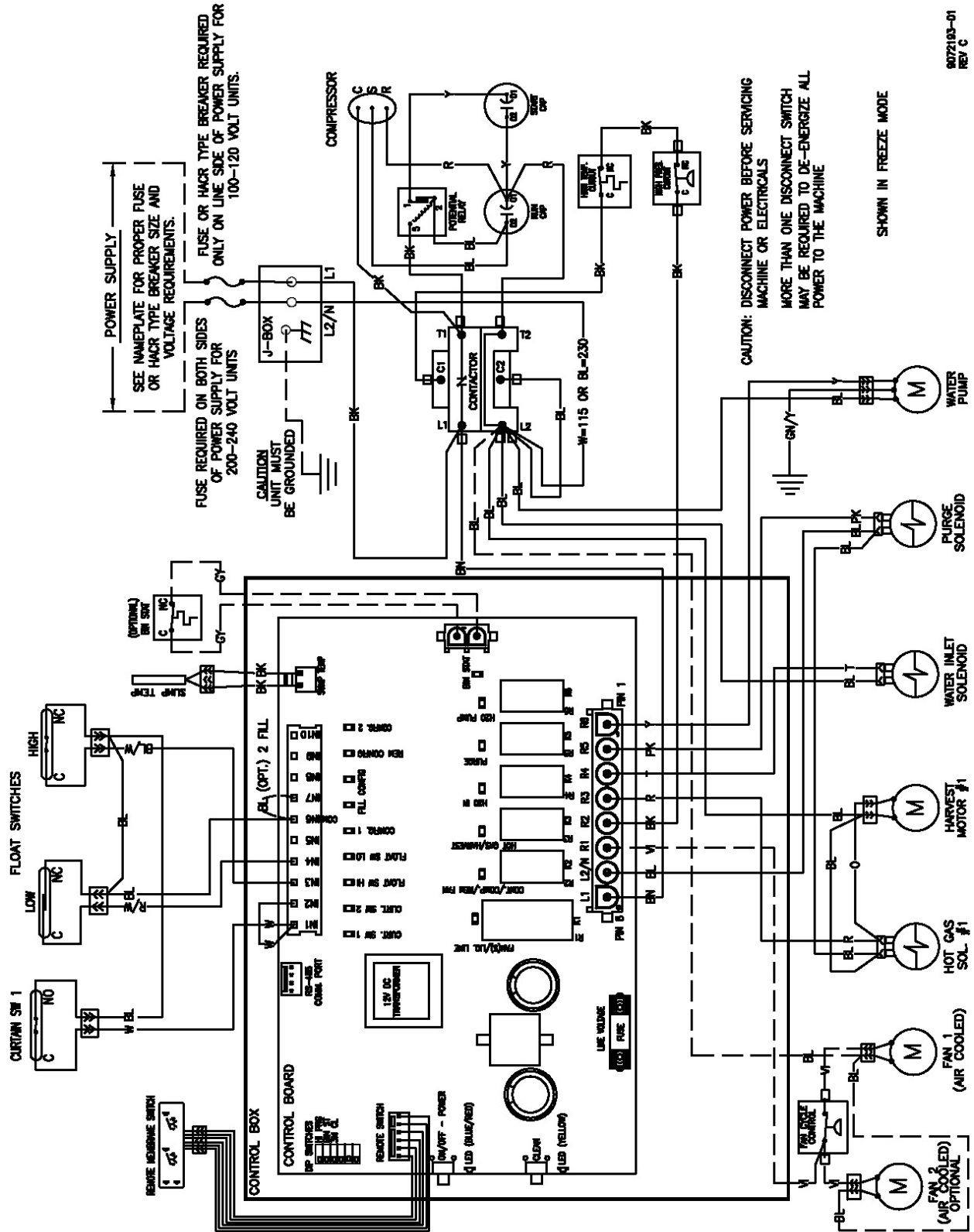

# CIM 220V - 240V, 50Hz, SINGLE PHASE, SINGLE EVAPORATOR PLATE AIR AND WATER COOLED UNITS

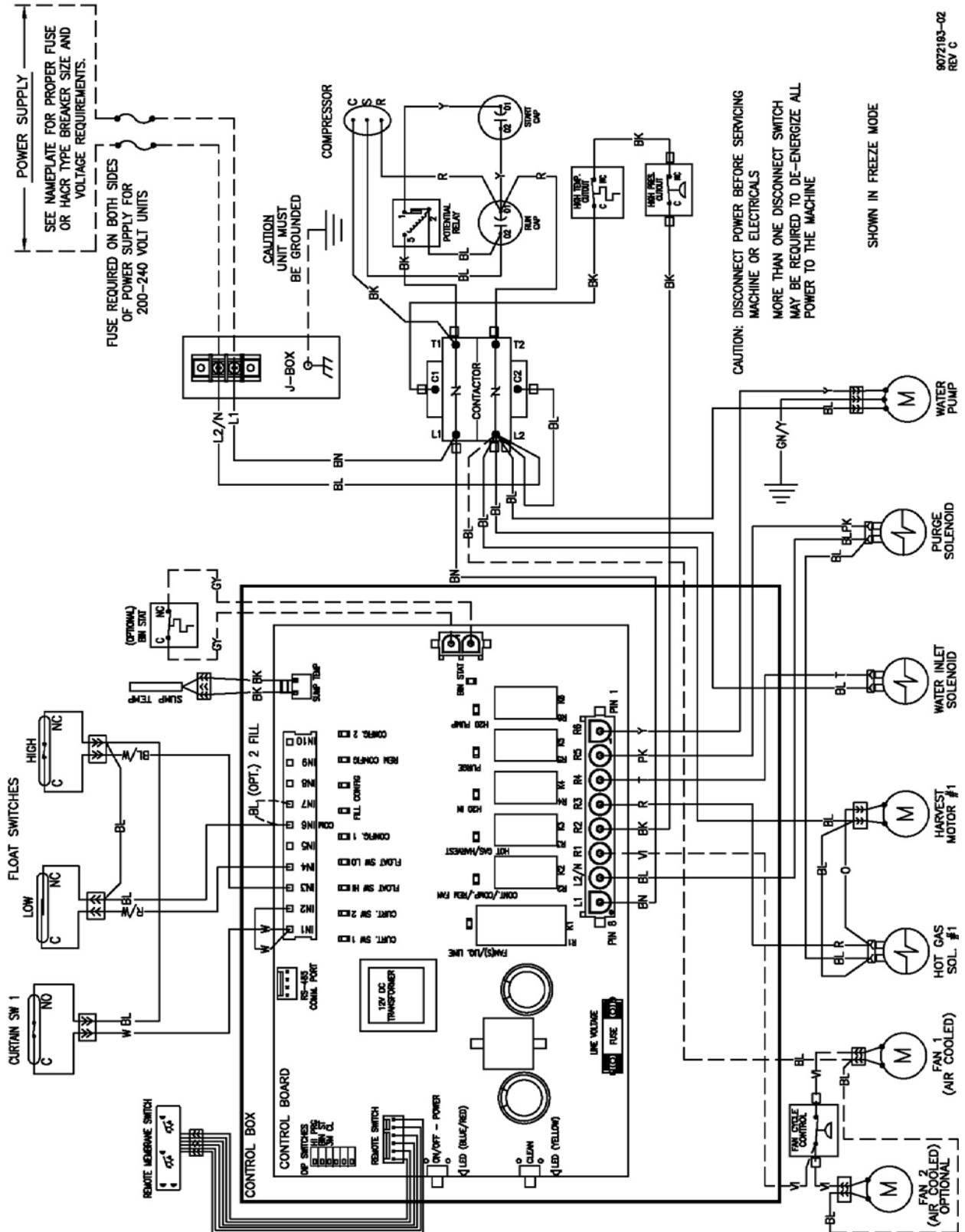











# CIM 220V - 240V, 50Hz, SINGLE PHASE, DUAL EVAPORATOR AIR AND WATER COOLED UNITS

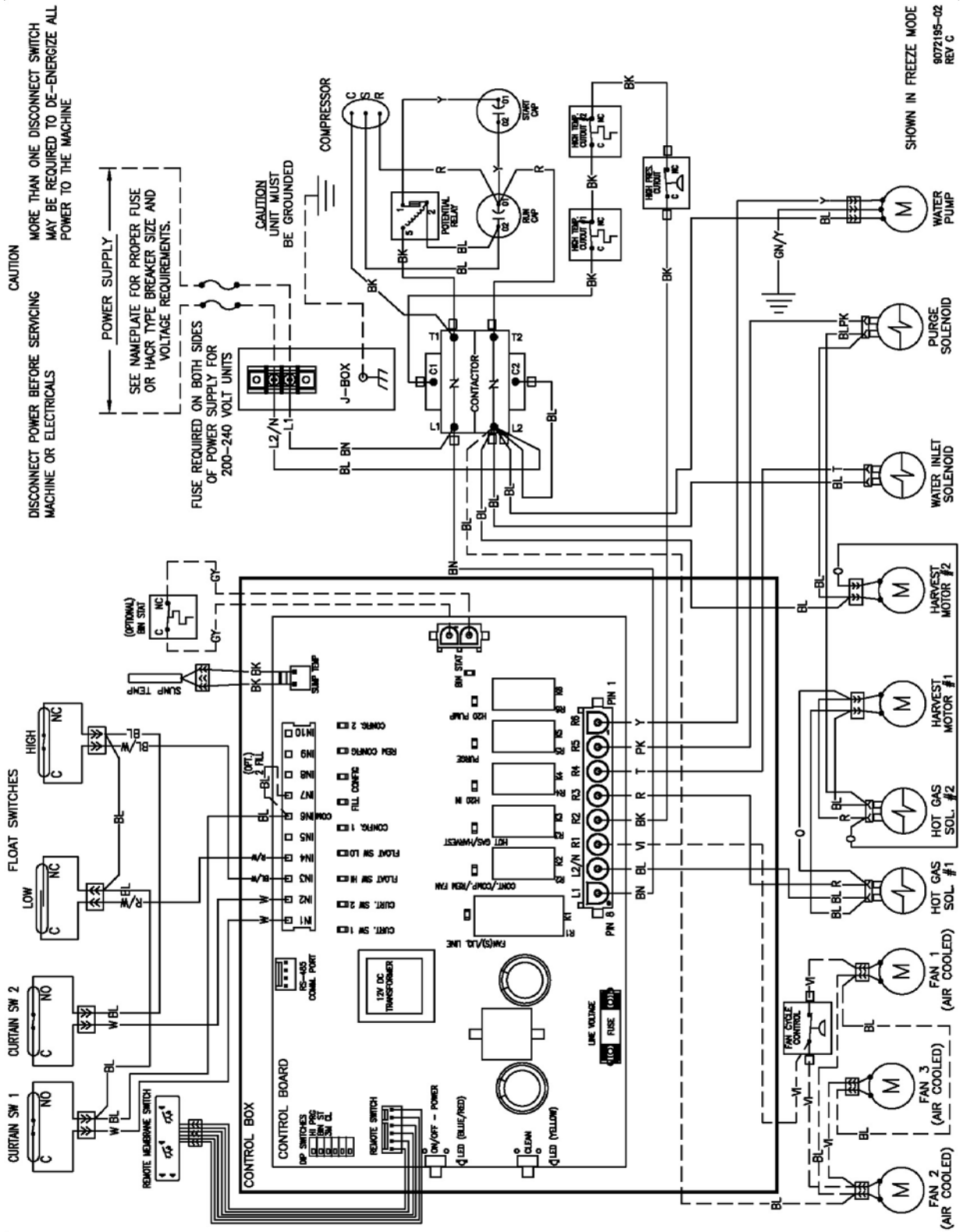





# CIM 220V - 240V, 50Hz, SINGLE PHASE, DUAL EVAPORATOR REMOTE COOLED UNITS

