

Ice-O-Matic®

Installation Manual GEMU090 Series



Ice-O-Matic Parts and Labor Domestic & International Limited Warranty

Mile High Equipment LLC (the "Company") warrants Ice-O-Matic brand ice machines, ice dispensers, remote condensers, water filters, and ice storage bins to the end customer against defects in material and factory workmanship for the following:

<ul style="list-style-type: none"> • Cube ice machines, compressed ice machines and remote condensers. - Thirty-six (36) months parts and labor 	<ul style="list-style-type: none"> • Ice storage bins -Twenty-four (24) month parts and labor
<ul style="list-style-type: none"> • Flake ice machines, GEMD Maker Dispensers, and GEMU Undercounter compressed ice machines - Twenty-four (24) months parts and labor 	<ul style="list-style-type: none"> • IOD model dispensers - Twenty-four (24) months parts, Twelve (12) months labor
<ul style="list-style-type: none"> • CD model dispensers - Thirty-six (36) months parts and labor 	<ul style="list-style-type: none"> • Water filter systems - Twelve (12) months parts and labor (not including filter cartridges)

An additional twenty-four (24) month warranty on parts (excluding labor) will be extended to all cube ice machine evaporator plates and all cube ice and compressed ice machines, except GEMU machines, compressors from the date of original installation. An additional thirty-six (36) month warranty on parts (excluding labor) will be extended to all flake ice machine and GEMD maker dispenser compressors from the date of original installation. The company will replace EXW (Incoterms 2000) the Company plant or, EXW (Incoterms 2000) the Company-authorized distributor, without cost to the Customer, that part of any such machine that becomes defective. In the event that the Warranty Registration Card indicating the installation date has not been returned to Ice-O-Matic, the warranty period will begin on the date of shipment from the Company. Irrespective of the actual installation date, the product will be warranted for a maximum of seventy-two (72) months from date of shipment from the Company.

ICE-model cube ice machines which are registered in the Water Filter Extended Warranty Program will receive a total of eighty-four (84) months parts and labor coverage on the evaporator plate from the date of original installation. Water filters must be installed at the time of installation and registered with the Company at that time. Water filter cartridges must be changed every six (6) months and that change reported to the Company to maintain the extended evaporator warranty.

No replacement will be made for any part or assembly which (I) has been subject to an alteration or accident; (II) was used in any way which, in the Company's opinion, adversely affects the machine's performance; (III) is from a machine on which the serial number has been altered or removed; or, (IV) uses any replacement part not authorized by the Company. This warranty does not apply to destruction or damage caused by unauthorized service, using other than Ice-O-Matic authorized replacements, risks of transportation, damage resulting from adverse environmental or water conditions, accidents, misuse, abuse, improper drainage, interruption in the electrical or water supply, charges related to the replacement of non-defective parts or components, damage by fire, flood, or acts of God.

This warranty is valid only when installation, service, and preventive maintenance are performed by a Company-authorized distributor, a Company-authorized service agency, or a Company Regional Manager. The Company reserves the right to refuse claims made for ice machines or bins used in more than one location. This Limited Warranty does not cover ice bills, normal maintenance, after-install adjustments, and cleaning.

Limitation of Warranty

This warranty is valid only for products produced and shipped from the Company after March 1, 2010. A product produced or installed before that date shall be covered by the Limited Warranty in effect at the date of its shipment. The liability of the Company for breach of this warranty shall, in any case, be limited to the cost of a new part to replace any part, which proves to be defective. The Company makes no representations or warranties of any character as to accessories or auxiliary equipment not manufactured by the Company. **REPAIR OR REPLACEMENT AS PROVIDED UNDER THIS WARRANTY IS THE EXCLUSIVE REMEDY OF THE CUSTOMER. MILE HIGH EQUIPMENT SHALL NOT BE LIABLE FOR ANY INCIDENTAL OR CONSEQUENTIAL DAMAGES FOR BREACH OF ANY EXPRESS OR IMPLIED WARRANTY ON THIS PRODUCT. EXCEPT TO THE EXTENT PROHIBITED BY APPLICABLE LAW, ANY IMPLIED WARRANTY OR MERCHANTABILITY OR FITNESS FOR A PARTICULAR PURPOSE ON THIS PRODUCT IS LIMITED IN DURATION TO THE LENGTH OF THIS WARRANTY.**

Filing a Claim

All claims for reimbursement **must be received at the factory within 60 days from date of service** to be eligible for credit. **All claims outside this time period will be void.** The model, the serial number and, if necessary, proof of installation, must be included in the claim. Claims for labor to replace defective parts must be included with the part claim to receive consideration. Payment on claims for labor will be limited to the published labor time allowance hours in effect at the time of repair. The Company may elect to require the return of components to validate a claim. Any defective part returned must be shipped to the Company or the Company-authorized distributor, transportation charges pre-paid, and properly sealed and tagged. The Company does not assume any responsibility for any expenses incurred in the field incidental to the repair of equipment covered by this warranty. The decision of the Company with respect to repair or replacement of a part shall be final. No person is authorized to give any other warranties or to assume any other liability on the Company's behalf unless done in writing by an officer of the Company.

GOVERNING LAW

This Limited Warranty shall be governed by the laws of the state of Delaware, U.S.A., excluding their conflicts of law principles. The United Nations Convention on Contracts for the International Sale of Goods is hereby excluded in its entirety from application to this Limited Warranty.

GEMU090

Installation and Use

Introduction

This manual includes information for the installation, operation and maintenance of the GEMU090 residential ice machine.

The GEMU090 was developed to offer fans of Ice-O-Matic's Pearl Ice form the ability to have that ice in their homes. Previously pearl Ice was only available in commercial establishments, where it developed a strong following because of the chewable nature of the ice. This machine makes authentic pearl ice, using the same process as the larger commercial machines.

Table of Contents

Product Description:	Page 2
Cabinet Dimensions	Page 3
Location Recommendations:	Page 4
Familiarization	Page 5
Door Swing	Page 6
Plumbing - Pump Model	Page 7
Plumbing: Gravity Drain Model	Page 8
Electrical and Start Up	Page 9
Use	Page 10
Maintenance	Page 11
How to remove scale from the ice making system.	Page 12

Outdoor Use Notice:

Keep from freezing. Severe damage will occur to the unit if left in or operated in temperatures beyond the limits listed in this manual. That damage is NOT covered by warranty.

Keep dry. Do not locate in low lying areas where puddles will accumulate.

Provide Shade: Heat gain from the sun will reduce the unit's ability to make and store ice, and ultraviolet radiation from the sun can potentially damage the unit's plastic components.

Water Supply: Avoid a long run of hose or tubing exposed to the sun. Plastic water supply tubing should be rated for potable water and include UV protection. Copper tubing is recommended.

Back Flow Prevention: The unit includes back flow prevention, no additional check valve is required.

Drainage: Do Not drain into swimming pool or onto grounds.

GEMU090

Installation and Use

Product Description:

This ice machine is designed to be used indoors, in a controlled environment or outdoors within certain limits.

The GEMU090 is made up of two major systems: the ice making system and the ice storage system. The ice making system is a continuous flow type ice machine, it makes ice when the ice level becomes low and stops when it is full.

The ice storage system is an insulated chest with a drain at the bottom for melting ice. It is not refrigerated, insuring that the bin contains fresh ice.

Installation Information

Dimensions:

The cabinet is fourteen and seven eighths inches wide by thirty three and three eighths to thirty four and three eighths inches high.

Utility and Operational Requirements

- The GEMU090 must be connected to a potable water supply.
- The water supply must have a conductivity of at least 10 microSiemens/cm.
- Minimum water pressure: 20 psi
- Maximum water pressure: 80 psi
- Minimum water temperature: 40 degrees F.
- Maximum water temperature: 90 degrees F.

It is designed to operate in wide range of air temperatures:

- Minimum air temperature: 50 degrees F.
- Maximum air temperature: 100 degrees F.

Although the machine will function within the listed ranges, it works best at water temperatures between 50 and 60 and air temperatures between 60 and 80.

Note: Ice making capacity goes down as the environmental temperatures go up, and will be severely reduced at temperatures over 90°F.

Operating a unit outside of the limits can cause problems that are not covered by the warranty and, if extreme, cause damage to the unit.

Water Quality

The water to the machine must be potable, or fit for human consumption. Beyond that, water supplies vary in the degree of mineral content. As this ice machine makes ice, all the water that flows into the machine is changed into ice. That includes any minerals that might be in the water. However, during ice making some minerals will stick to the ice making components. The higher the mineral content, the more mineral build up will occur. Water filters are a partial help, as they will remove the suspended solids, but water treatment is needed for the dissolved solids, which are part of the water and cannot be filtered out.

RO Water

This machine can be supplied with Reverse Osmosis water, but the water conductivity must be no less than 10 microSiemens/cm. A reverse osmosis system should include post treatment or blending to satisfy the R.O. water's potential aggressiveness.

Deionized water is not recommended and could damage the machine.

Because water softeners exchange one mineral for another, softened water may not improve water conditions when used with ice machines

Electrical power

The unit must be on its own 115 volt, 60 Hz, 15 amp circuit. It is equipped with a power cord and can be plugged into a nearby outlet. Extension cords are not allowed by most codes. Follow all applicable codes.

Warranty Information

Warranty information is supplied on the inside front cover of this manual. Refer to it for coverage. In general, the warranty covers defects in materials or workmanship and does not cover corrections of installation errors or maintenance.

GEMU090

Installation and Use

Cabinet Dimensions

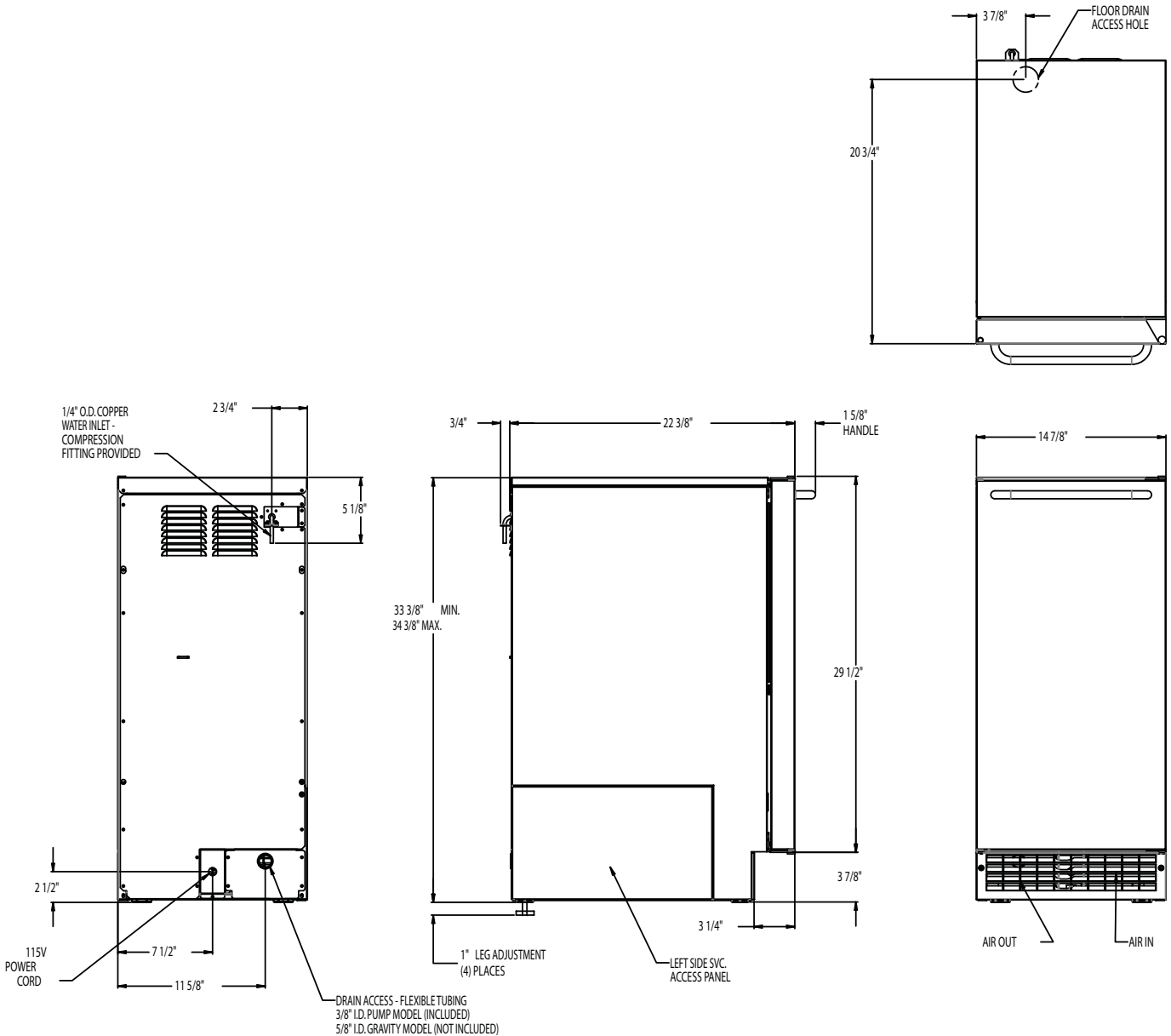

Ice-O-Matic Ice Systems are designed and manufactured with the highest regard for safety and performance. They meet or exceed the standards of agencies like ETL.

Ice-O-Matic assumes no liability or responsibility of any kind for products manufactured by Ice-O-Matic that have been altered in any way, including the use of any parts and/or other components not specifically approved by Ice-O-Matic.

Ice-O-Matic reserves the right to make design changes and/or improvements at any time. Specifications and designs are subject to change without notice.

GEMU090

Installation and Use

Location Recommendations:

The machine can be built into a cabinet. It is an air cooled refrigeration system and so air flows in and out of it through the grill at the bottom front. The grill must not be blocked by any covering door or other obstruction.



The machine is a gravity drain model and must have a building drain connection below the level of the drain tube at the back of the cabinet. An optional field installed drain pump kit is available which can force drain water up a maximum of 10 feet, allowing it to be located where a gravity drain isn't available.

Kickplate Extension: In some situations the leg levelers will be extended enough to become visible. A kit to extend the kickplate over the legs is **KKPF**.

Cabinet Stability: In some free standing installations it may be prudent to add a bracket that secures the back of the cabinet to a wall. That kit number is **KATB**.

Drain Conversion: A gravity drain model can be converted to a drain pump model by installing a drain pump kit. The drain pump kit consists of a drain pump, wiring harness and associated tubing. The part number is **KPU090**.

Installation Notes

Built In Situations: If a finished floor is to be installed in the area after the ice machine has been built in, shims the expected thickness of the floor should be installed under the unit to keep the machine level with the planned floor level.

Note: The water connection is at the back and adds a few inches to the cabinet depth. Minimum clearance is 0 in. at the top, 2 in. at the rear and 1/8 in. at each side.

Installations on a slab: Use a pump model and pump the water to the point of drainage. Pump models will pump 1 story (10 feet) high.

Installations over a crawl space or basement:

Either gravity drain or pump model units may be used, if there is not enough room behind the machine for a drain/waste receptacle, the drain will have to be below the floor.

Note: When installed in a corner, the door swing may be limited due to handle contact with the wall or cabinet face.

All models require a water supply. Water supplies vary in the degree of mineral content. High mineral content water will require more frequent maintenance. Water filtration may improve the taste of the ice as well as cut down on some of the mineral build up.

GEMU090

Installation and Use

Familiarization

The control panel is visible when the door is opened. It has three indicator lights and two switches.

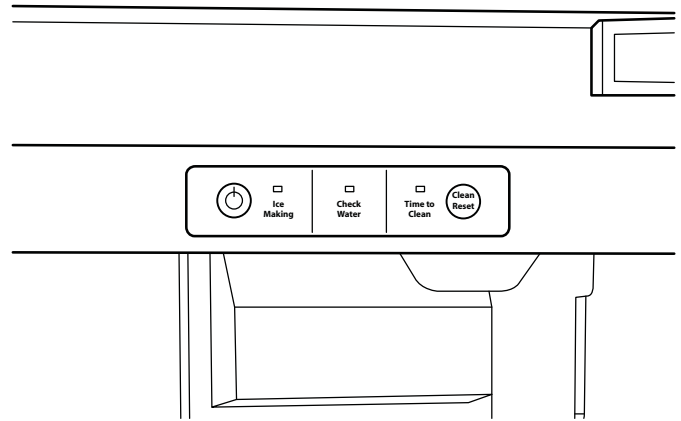

Control Panel

The model and serial number plate is located on the bottom of the control panel box. The Bin Light and Ice Level Sensor are also visible from that angle, as is the Ice Chute.

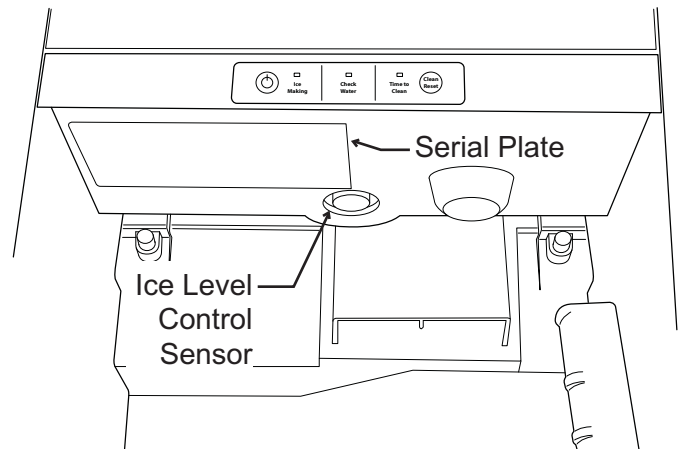

Serial Number Plate

The Scoop Holder is located on the right side of the ice storage bin. The normal ice level is about level with the scoop holder.



Scoop Holder

GEMU090

Installation and Use

Door Swing

The door can be attached to open with hinges on the left or right. Retain all screws for re-use.

To change:

1. Remove top hinge pin from hinge.



2. Tilt top of door away from cabinet and lift door off bottom hinge.



3. Remove two screws and top hinge.
4. Remove plugs or screws from lower cabinet bracket
5. Attach top hinge to lower cabinet bracket using original screws.

6. Remove original bottom hinge.



7. Remove two plugs or screws from upper cabinet bracket.
8. Attach bottom hinge to upper cabinet bracket using the original screws.
9. Place the door on bottom hinge, tip up to slide under top hinge.
10. Insert hinge pin into top hinge and door.
11. Tighten hinge pin.
12. Replace screws or plugs into holes left by hinges.
13. Check action and swing of door.
13. Return kickplate and front service panel to their original positions and attach to the cabinet using the original screws.

GEMU090

Installation and Use

Plumbing - Pump Model

Drains

There are two types of ice machine models, one that drains by gravity and one that has an internal drain pump.

Drain Pump Model drain installation

1. Locate the coil of 3/8" ID plastic drain tubing secured to the back of the unit.
2. Route the plastic drain tube from the back of the unit to the drain connection point.

The drain connection point can be as high as 10 feet above the ice machine. The drain pump includes a check valve to prevent re-pumping water in the drain hose.

IMPORTANT NOTE: Often an air gap is required by local codes between the ice maker drain tube and the drain receptacle.

Water Supply

The recommended water supply tubing is 1/4 inch OD copper. Stainless steel flex or reinforced PCV tube may also be used. Install an easily accessible shut-off valve between the supply and the unit. This shut-off valve should not be installed behind the unit.

The water connection is at the back of the cabinet. Connect using a compression fitting, one is supplied tied to the water inlet tube. When built in: Coil enough tubing behind the machine so it can be pushed into the cavity without kinking the tubing.

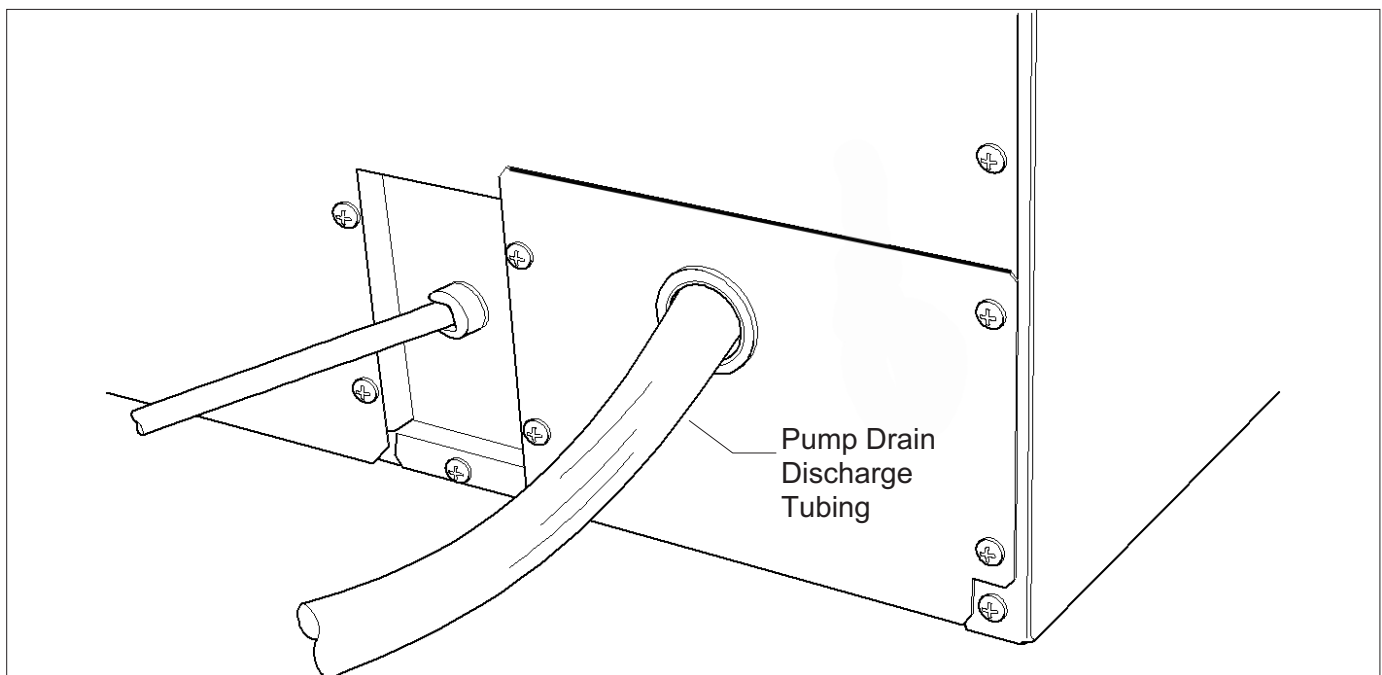
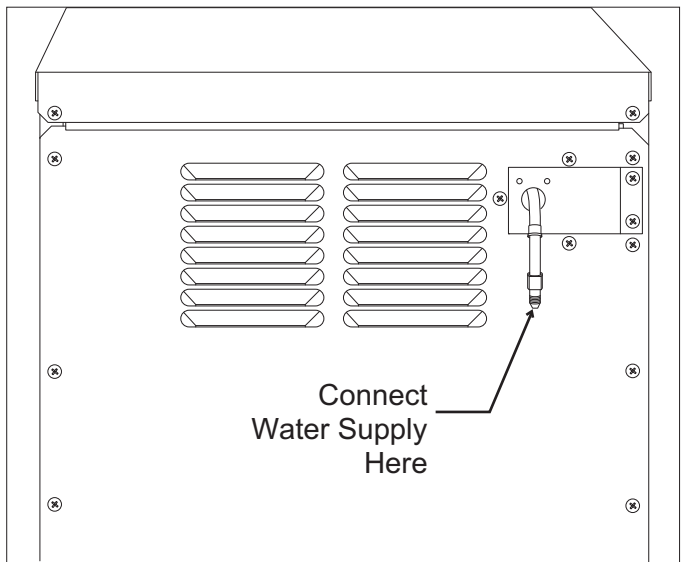

GEMU090

Installation and Use

Plumbing: Gravity Drain Model

Caution: Restrictions in the drain system to the machine will cause water to back up into the ice storage bin and melt the ice. Gravity drain tubing must be vented, have no kinks and slope to the building drain. Air gaps are typically required by local code.

1. Place the ice machine in front of the installation opening. Adjust leveling legs to the approximate height.
2. Remove the upper back panel if needed for access to the drain fitting.

Note: If you are connecting a gravity drain model and the drain opening has been located in the floor under the base pan according to the pre install specifications, follow steps 3 through 5 to drain the unit through the base. If not, proceed to step 6b.

3. Remove the clamp and barbed elbow and take off the plastic cover in the base pan below the drain hose.
4. Connect a straight 5/8" barbed connector to the drain hose, securing with the clamp removed in step 3.
5. Cut an 8" piece of 5/8" ID X 7/8" OD tygon (clear plastic) tubing. Slide one end of the tube onto the outlet of the barbed connector and secure with a

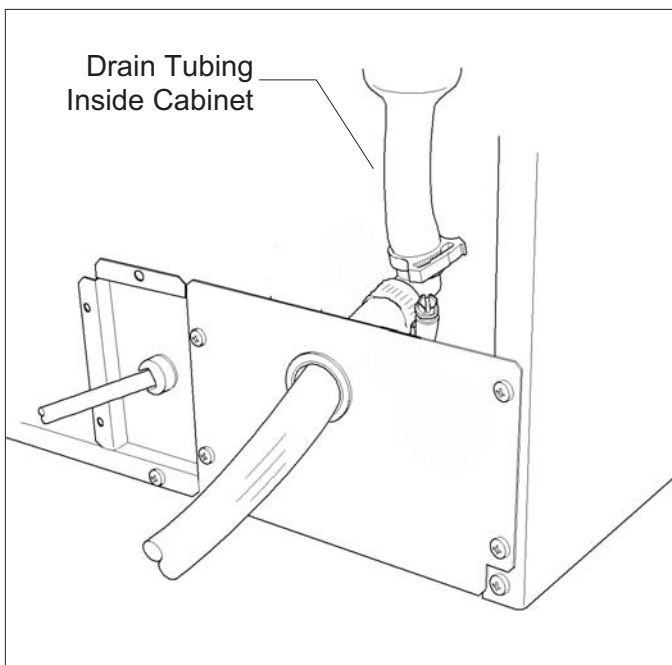

clamp. Leave the other end of the tube lying on the floor of the base pan until the unit is positioned over the floor drain.

6. Route the drain tube. Either a) Insert the drain tube through the base pan into the floor drain or b) Route the drain tube through the hole in the lower back panel and connect to barbed elbow and secure with a clamp.
7. Reinstall the upper back panel.

Water Supply

The recommended water supply tubing is 1/4 inch OD copper. Stainless steel flex or reinforced PCV tube may also be used. Install an easily accessible shut-off valve between the supply and the unit. This shut-off valve should not be installed behind the

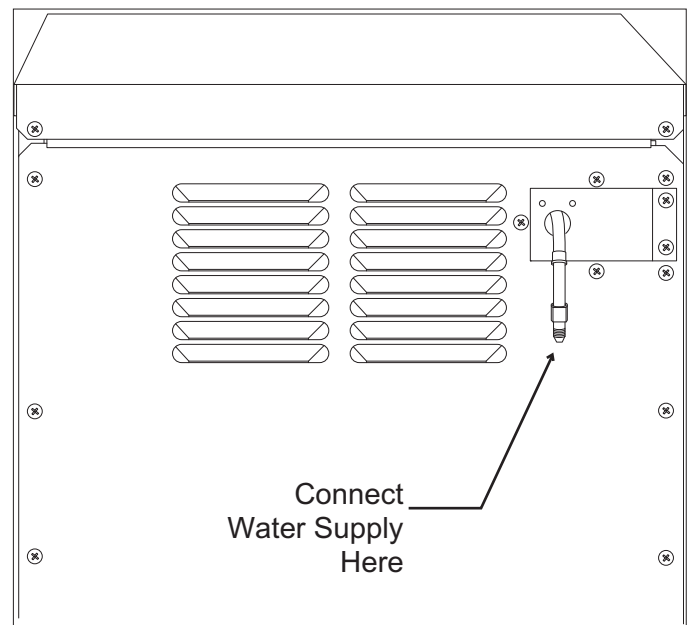

unit.

The water connection is at the back of the cabinet. Connect using a compression fitting, one is supplied tied to the water inlet tube.

When built in: Coil enough tubing behind the machine so it can be pushed into the cavity without kinking the tubing.

GEMU090

Installation and Use

Electrical and Start Up

The ice machine is supplied with a power cord. Do not remove the grounding pin from the cord's plug. Do not use extension cords. Follow all codes.

Connect the machine to its own 115 volt, 15 amp circuit.

1. If the electrical outlet for the ice maker is behind the unit, plug in the unit.
2. Position the unit in the installation opening.
3. Turn on the water supply. Make sure that the ice maker is plugged in and the power is on.
4. Slide unit into installation opening, paying careful attention to water supply and drain connections. Do not kink!
5. Pour a couple of quarts of water into the ice storage bin; on drain pump equipped machines the drain pump should start and water should pump out. Check for leaks.
6. Replace the service access panel.
7. Level the unit as needed.

Installation check list:

1. Has the unit been connected to the proper water supply?
2. Has the water supply been checked for leaks?
3. Has the unit been connected to a drain?
4. Has the drain been tested for flow and leaks?
5. Has the unit been connected to the proper electrical supply?
6. Has the unit been leveled?
7. Have all packing materials been removed from the machine?
8. Has the door covering been installed?

Initial Start Up

1. Turn on the water supply and check for leaks.
2. Switch on the electrical power.
3. Push and release the On/Off switch to start the machine. The Ice Making light next to the On/Off switch will glow Green.

Warm air will flow out of the left front grill.

It will take about 10 minutes for the ice machine to begin dropping pearl ice into the storage bin. It is normal for that ice to melt and ice will continue to melt, but at a slower rate. It will take about 6 - 7 hours to fill up the ice storage bin. The bin holds about 20 lb of ice when full.

Ice level control

The ice level control for the GEMU090 is an ultrasonic sensor, located above the ice storage area. It is automatic and there is no adjustment to make. When ice melts or is used, and the ice level drops below a preset distance the control turns the ice making system back on. It makes ice until the preset level is reached. Placing your hand in the unit to remove ice does not affect the ice level.

GEMU090

Installation and Use

Use

No special instructions are needed for use. Just take as much ice as you need, the machine will replace it. A scoop is provided, and it can be stored in the machine using the loop of tubing on the right side as a holder.

The machine can be shut off anytime by just pushing and releasing the On/Off button.

What shouldn't be done?

Never keep anything in the ice storage bin that is not ice. Objects like wine or beer bottles are not only unsanitary, but the labels can slip off and plug up the drain.

Never allow the machine to operate without regular cleaning. The machine will last longer if it is kept clean. Regular cleaning should happen at least once per year, and preferably twice. Some water conditions will dictate even more frequent cleaning of the ice making section, and some carpets or pets will dictate more frequent cleaning of the condenser.

Note: The Time to Clean light will switch ON after 6 months of use. It will remain ON until the ice making system is cleaned using the process on page 14.

Noise:

The ice machine is designed for quiet operation, but will make some noise during the ice making cycle.

Ice Making

During ice making, pearl ice will drop into the bin at an irregular rate; sometimes there will be little ice falling while at other times a group of pearls will fall. Some water drops may also come out with the ice. Both conditions are normal.

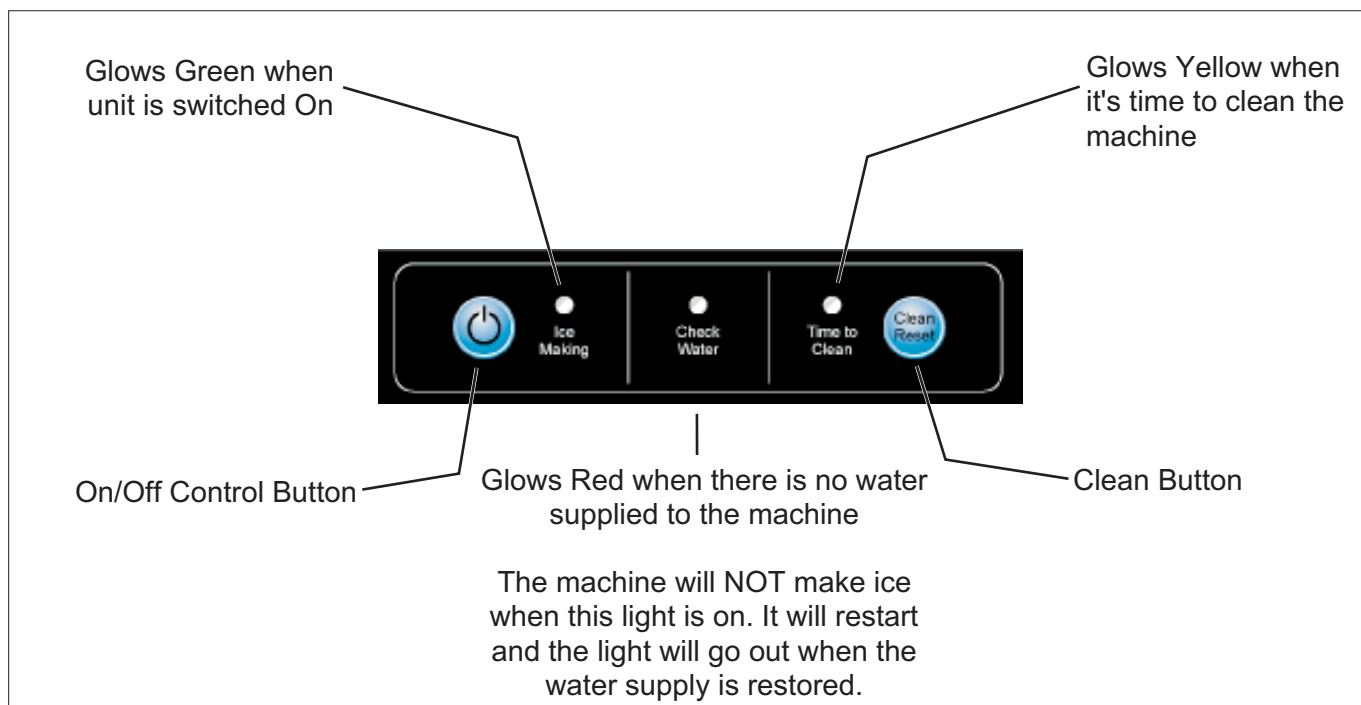

Control Panel

GEMU090

Installation and Use

Maintenance

Ice-O-Matic **strongly recommends regular maintenance** of this ice machine. During normal operation mineral scale that is in the water supply will gradually build up on the ice making surfaces. That build up can cause excessive loading of the ice making system, which can cause premature failure. Regular removal of the mineral scale will lengthen the product's life.

Suggested maintenance schedule: every 6 months.

Type of maintenance: Scale removal, water seal check, water reservoir check, bin drain check, air cooled condenser cleaning and storage bin sanitation.

Condenser cleaning

The condenser is like the radiator on a car, it has fins and tubes that can become clogged with dirt and lint. To clean:

1. Remove the kickplate and front service panel.

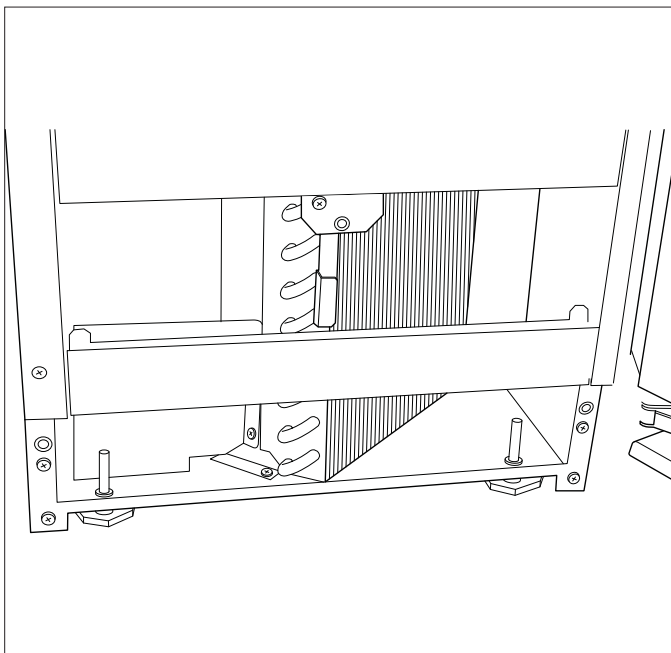

2. Locate the condenser surface.
3. Vacuum the surface, removing all dust and lint.

Caution: Do not dent the fins.

4. Return the kickplate and front service panel to their original positions. Fasten them to the cabinet using the original screws.

Winterizing

1. Clean the ice making system per the instructions in the Maintenance section.
2. Open the door and push and release the On/Off switch to turn the machine off.
3. Turn off the water supply.
4. Remove the back wall of the ice storage bin.
5. Remove drain plug and drain the water reservoir, return plug to its original position.
6. Drain pump models should have about 1/2 gallon of RV antifreeze (propylene glycol) poured into the ice storage bin drain.

Note: Automotive antifreeze must NOT be used.

7. Switch off and unplug the machine.

GEMU090

Installation and Use

How to remove scale from the ice making system.

Cleaning this machine involves adding a solution of scale remover and water to the ice machine and continuing to add it as it makes ice. The scale remover must be diluted to the correct ratio. A squirt bottle will make adding the scale remover much easier when the unit is built in. If not built in, remove the top panel for reservoir access.

Recommended tools: Rubber gloves, squirt bottle & scale remover. Pre-Mixed 16 oz squirt bottle of scale remover is part number PMC090.

1. Scoop out and discard all of the ice.
2. Press and release the On/Off button.

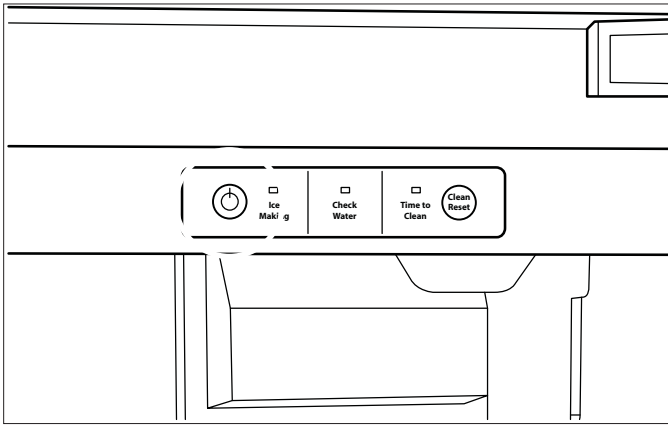

3. Open door and locate screws at upper back wall of bin. Remove the two screws.

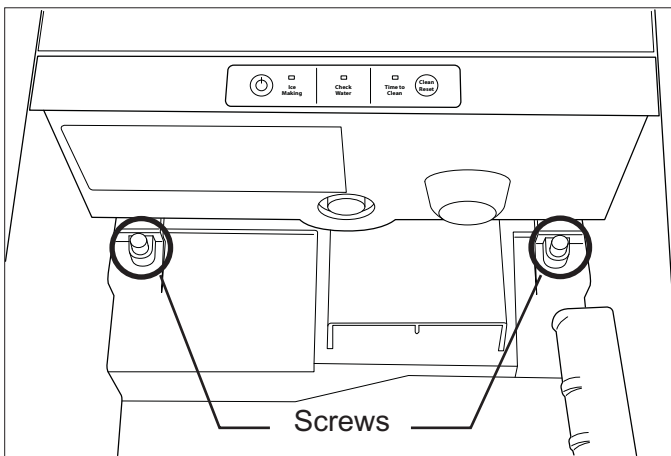

4. Remove the back wall of the bin by lowering it down past the scoop holder, feel free to rotate the scoop holder loop down to make more room.

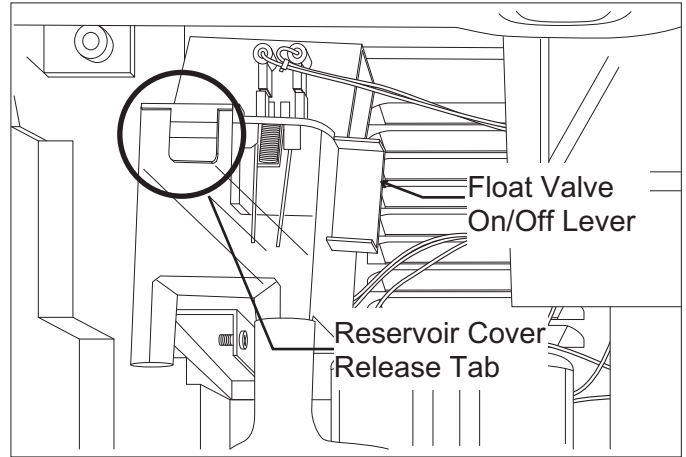

5. Push tab on front edge of reservoir cover and remove the cover. Note: Adjacent wires are low voltage and are not hazardous.

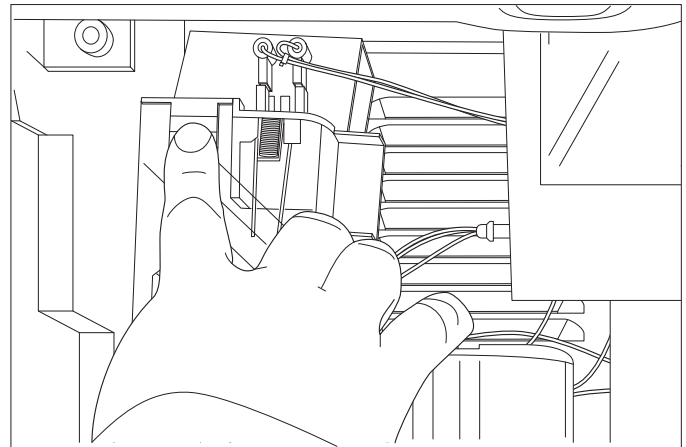

Push In Tab to Release Cover

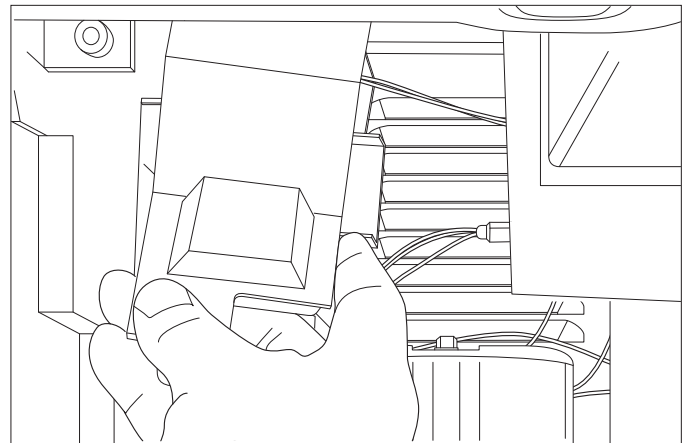

Lift Reservoir Cover to Remove

GEMU090

Installation and Use

6. Locate blue float valve on/off lever. Move lever up about half way to shut water off.

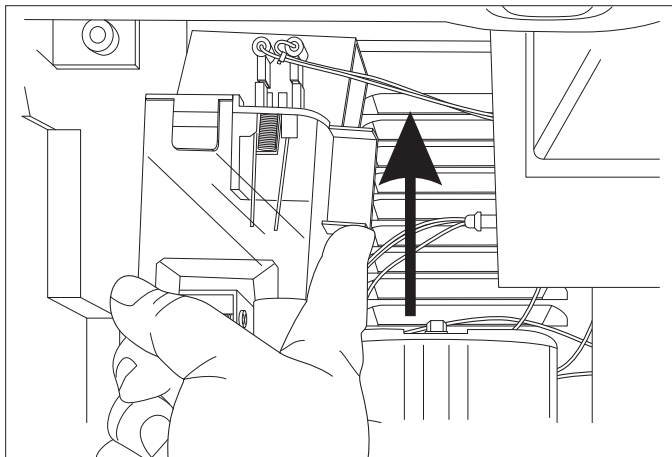

7. Locate drain plug and pull the drain plug out to drain the reservoir and evaporator. When draining is complete, return the plug to its original position.

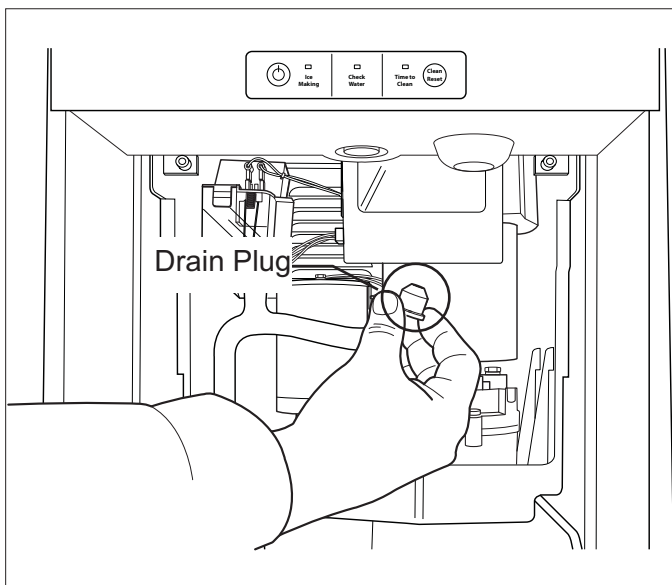
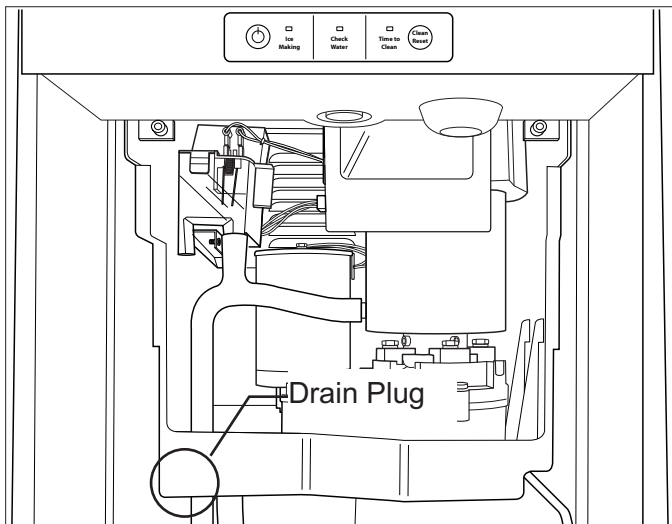

8. Obtain pre-mixed Ice-O-Matic Clear 1 Scale remover solution (with squirt bottle) or mix a solution of Clear 1 with water: 2.5 ounces of Clear 1 with 1 quart (32 oz) of warm water.

WARNING



Ice machine scale remover contains acids. Acids can cause burns.

If concentrated cleaner comes in contact with skin, flush with water. If swallowed, do NOT induce vomiting. Give large amounts of water or milk. Call Physician immediately. Keep out of the reach of children.

Note: Take care not to spill any scale remover on any nearby surface. Immediately wipe any spill with baking soda and water.

9. Fill the 16 oz squirt bottle with the diluted scale remover.

10. Fill the reservoir with the scale remover solution using squirt bottle or other container. That will be about 8 ounces or half a squirt bottle.

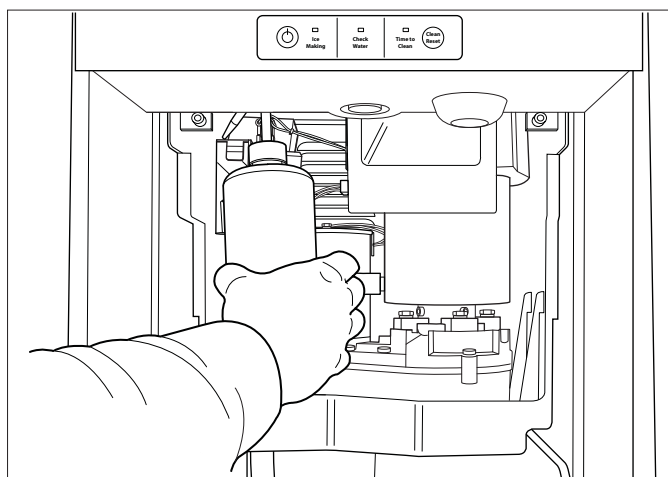

Fill Reservoir Using Squirt Bottle

GEMU090

Installation and Use

11. Press and HOLD both the Clean-Reset and On/Off buttons for 5 seconds. The Time to Clean light will blink on and off.

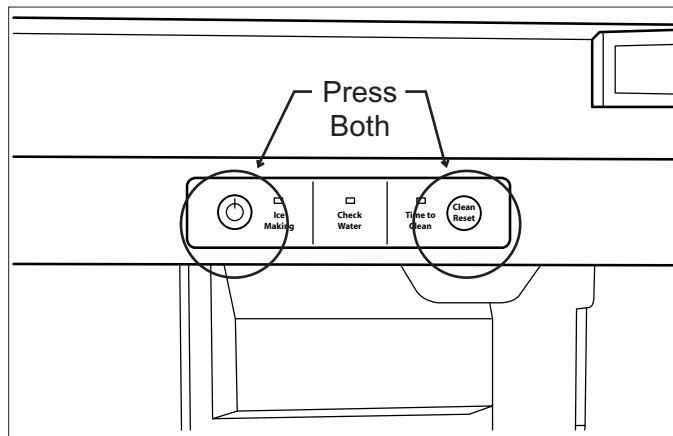

12. The auger motor alone will be operating for 10 minutes, after that the compressor will start and in about 5-8 minutes the machine will start to make ice. The Time to Clean light will now glow steady until the clean cycle is complete.

Caution: Keep fingers away from moving parts.

12a. After ice making starts, continuously add scale remover solution to the reservoir to keep it about half full.

12b. When all 16 oz of the solution is used, move the float valve lever down to the On position.

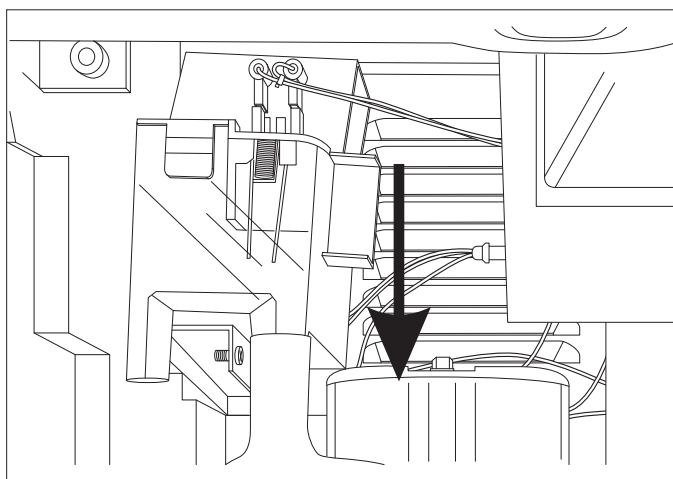

After 40 minutes the ice machine and all the control panel lights will shut off.

13. Pull the drain plug again to drain the system, then replace it.

13a: Optional - move float lever up to Off, add locally approved sanitizer* to water system, then repeat step 13. Move the float lever down to On.

14. Return the reservoir cover to its original position.

15. Return the upper back wall of the bin to its original position and secure it with the original screws. Push in at bottom to snap it into place.

16. Pour a gallon of lukewarm (95°F. – 115°F.) water into the bin to flush out the drain and melt all ice that was made during the cleaning process. Be sure all ice is melted.

17. Clean the bin liner of mineral scale by using any left over scale remover solution to scrub the scale off of the liner. If none is left over, mix a solution of 2.5 ounces of Clear 1 Scale Remover and 1 quart of water.

18. Rinse the liner with hot water.

19. Sanitize the ice chute, ice sweep, breaker and bin interior using a locally approved sanitizer.*

20. Push and release the On/Off button to restart ice making.

The ice scoop should be washed regularly, wash it just like any other food container.

* A potential sanitizer may be made by mixing 1 ounce of liquid household bleach to 2 gallons of lukewarm (95°F. – 115°F) water.

Other Maintenance

While cleaning the system with scale remover, check for water leaks at the bottom of the evaporator. If any are found, call for service.

Note: It is normal for some lime scale to form on the gear reducer cover. Wipe up any loose scale.

Check the top bearing.

The top bearing is non-metallic and requires no lubrication. However, it should be checked for wear occasionally. The top panel must be removed to access the bearing.