



2323 HIGH PERFORMANCE

POST-MIX DROP-IN DISPENSER



FEATURES

- Large ice capacity** - Ice chest has 80 or 100 lb capacity
- Options** - Available with 5, 6, or 8 valves (8 valve has 2 ambient syrups and 6 chilled syrups)
- Insulated** - Foamed polyurethane insulation
- Convenient** - Front inlet fitting location
- Ease of use** - Large, extended drip tray provides extra room for cup staging and is removable for ease in cleaning

- Flexibility** - High capacity cold plate delivers 5-2-1 carb to non-carb flexibility
- Ambient option** - Interior syrup connections provide opportunity to bypass syrup cooling if desired

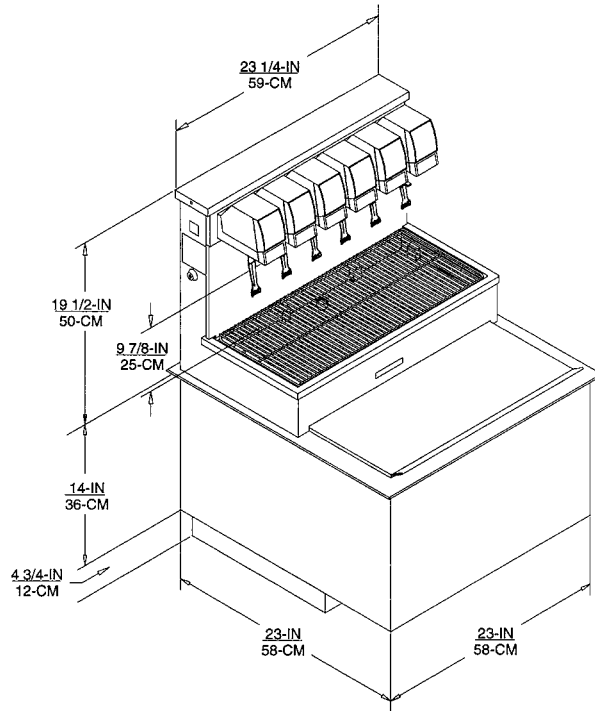

| PART NUMBER | DESCRIPTION |
|-------------|---|
| 631100051 | Drop-in dispenser 5 UFB-1™ 2-4 oz sanitary lever valves, 100 lb (45 kg) bin |
| 631100054 | Drop-in dispenser 6 UFB-1™ 2-4 oz sanitary lever valves, 80 lb (36 kg) bin |
| 631100056 | Drop-in dispenser 6 UFB-1™ 2-4 oz sanitary lever valves, 100 lb (45 kg) bin |
| 631100055 | Drop-in dispenser 8 UFB-1™ 2-4 oz sanitary lever valves, 80 lb (36 kg) bin |
| 631100057 | Drop-in dispenser 8 UFB-1™ 2-4 oz sanitary lever valves, 100 lb (45 kg) bin |
| 162111002 | Drop-in ice chest w/sealed in nine circuit cold plate and slotted rim |
| 162111004 | Drop-in ice chest w/sealed in nine circuit cold plate |
| 162111002 | Drop-in ice chest without sealed in cold plate |
| 630001218 | Cabinet stand for 2323 drop-in dispenser, assembled |
| 630001205 | Cabinet stand for 2323 drop-in dispenser, not assembled |

TECHNICAL SPECIFICATIONS

TYPE OF VALVES UFB-1™ post-mix

NUMBER OF VALVES 5, 6 or 8

CUP CLEARANCE 9.75" (248 mm)

CONNECTIONS Water: 0.375" (9.5 mm)
barb fitting
Syrup: 0.375" (9.5 mm)
barb fitting

COUNTER TOP CUT OUT 23.25" x 23.25"
(591 mm x 591 mm)

DRAIN SIZE 0.75" (19.1 mm)
flexible hose

ELECTRICAL REQUIREMENTS . . 120 V / 60 Hz / 1.5 Amps

SHIPPING WEIGHT 335 lb

AGENCY LISTING



Transformer is UL and
cUL listed



IN THE U.S.A.
Ph: 800.238.3600
Fax: 800.258.0255

OUTSIDE THE U.S.A.
Ph: 763.488.8200
Email: webmaster@cornelius.com

101 Broadway Street West
Osseo, MN 55369
www.cornelius.com