

OPERATOR'S MANUAL

AUTOMATED BEVERAGE SYSTEM



This equipment chapter is to be inserted in the Beverage Systems section of the *Equipment Manual*.

MANUFACTURED
EXCLUSIVELY FOR
McDONALD'S®
BY
IMI CORNELIUS

PHONE (800) 238-3600
www.cornelius.com

**FOR SERVICE CALL
COKE SMILE
1-800-241-COKE**

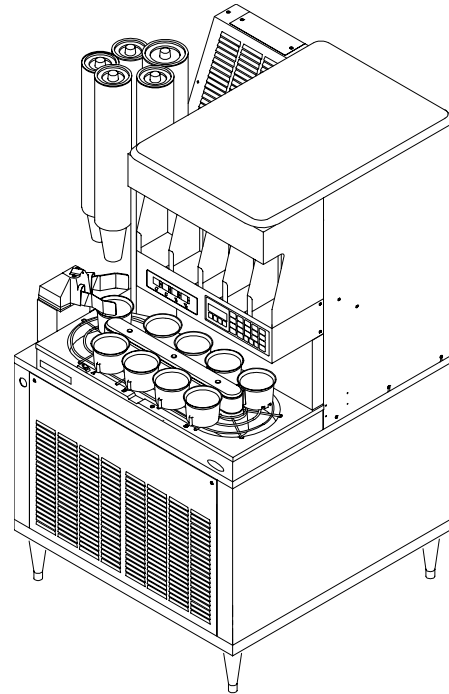

TABLE OF CONTENTS

WARRANTY	Page 2
INTRODUCTION	Page 4
SAFETY	Page 4
PARTS IDENTIFICATION/FUNCTION	Page 5
OPERATION MODES.....	Page 11
AUTOMATIC OPERATION.....	Page 12
SEMIAUTOMATIC OPERATION.....	Page 17
MANUAL OPERATION.....	Page 19
MAJOR SUBSYSTEMS.....	Page 23
DAILY START-UP	Page 39
CLOSING/SANITATION PROCEDURES	Page 41
DAILY CLEANING PROCEDURES.....	Page 44
MONTHLY	Page 45
QUARTERLY CLEANING/SANITATION PROCEDURES	Page 46
TROUBLESHOOTING.....	Page 50
WIRING & PNEUMATIC DIAGRAMS.....	Page 55

Part No. 569000181OPR
April 21, 2004
Revision: D
Revised: July 29, 2005

This manual is for the exclusive use of licensees and employees of McDonald's Systems, Inc.

Automated Beverage System

McDonald's Automatic Beverage System

WARRANTY, DISCLAIMER OF WARRANTY AND LIMITATION OF REMEDY

Products covered by this Warranty include only Automatic beverage Dispenser ("ABS") manufactures or sold by Cornelius after the date hereof (herein "Products"). THE TERM "PRODUCTS" DOES NOT INCLUDE, AND THIS WARRANTY IN NO EVENT EXTENDS TO, ITEMS NOT MANUFACTURED OR SOLD BY CORNELIUS, SUCH AS ANY POS SYSTEMS (INCLUDING CABLE CONNECTING THE POS TO THE ABS) AND ANY RECIRCULATING SYSTEM SUPPLYING CO2 WATER, WATER OR SYRUP TO THE ABS.

WARRANTY

IMI Cornelius Inc., (Cornelius") warrants to the original McDonald's purchaser with respect to each product purchased that:

1. For the lesser of (i) two (2) years from the date of installation or (ii) twenty seven (27) months from the date of shipment by Cornelius, all parts comprising such Product (except Excluded Parts as defined below and the refrigeration system of the precooler) are free from defects in materials;
2. For the lesser of five (5) years from the date of installation or sixty-three (63) months from the date of shipment by Cornelius (and subject to the service limitation set forth below), the parts (except Excluded Parts) comprising the refrigeration system of the precooler of such Product, being only the compressor, evaporator, condenser, and interconnecting tubing (but not access valves or any other part) are free from defects in materials; and
3. For the lesser of one (1) year from the date of installation or (ii) fifteen (15) months from the date of shipment by Cornelius that such Product conforms with those industry, government, or professional organizations standards to the extent expressly set forth in written product information disclosures in Cornelius product literature and documentation;

Provided that the foregoing shall not apply to any warranty claim not made as promptly as possible and in any event within thirty (30) days after the discovery thereof to the Cornelius Service Department at 101 Broadway Street West, Osseo, MN, (800) 238-3600.

For the purposes of the foregoing warranties, "Excluded Parts" include all water filter cartridges, coin mechanisms, light bulbs, fuses, glass diaphragms, seals, o-rings, silicone or rubber parts, parts in contact with water or the product dispensed and which become inoperative due to scale or chemical change, as well as normal maintenance items.

All service warranty claims above \$400 require Cornelius authorization prior to repair/replacement. If service occurs outside the standard Cornelius business hours, claim will be denied if part(s) are not returned and/or returned are not found to be defective upon further inspection. See next paragraph.

It is not a defect, and thus these warranties do not apply to, repair, replacement or other service required by or loss or damage resulting from (i) other than normal and proper use and service conditions with respect to such Product, (ii) use of the product other than exclusively with soft drinks, soft drink syrup, or iced tea identified in writing by Cornelius, (iii) improper voltage, (iv) inadequate wiring, (v) abuse, (vi) accident, (vii) alteration, (viii) risk of transportation, (ix) misuse, (x) neglect, (xi) unauthorized repair, (xii) fire, flood or other acts of God, (xiii) improper cleaning, or failure to follow installation, operating, or maintenance instructions, nor does these Warranties cover normally prescribed maintenance, cleaning, and adjustments.

IMI CORNELIUS
www.cornelius.com

Automated Beverage System

Disclaimer of Warranty

THIS WARRANTY IS IN LIEU OF ALL OTHER WARRANTIES, EXPRESS OR IMPLIED, INCLUDING WARRANTIES OF MERCHANTABILITY AND FITNESS FOR A PARTICULAR PURPOSE, ALL OF WHICH OTHER WARRANTIES ARE HEREBY DISCLAIMED AND EXCLUDED.

Remedy, Limitation of Remedy and Disclaimer of Liability

The remedy for any breach of this Warranty is limited to the repair or replacement of the defect part or the Product in which it is included, at the option of Cornelius. To the extent that, in the judgement of Cornelius, repair or replacement should be performed through on-site service, such service is included in the Warranty for the lesser of two (2) years from the date of installation or (ii) twenty seven (27) months from the date of shipment by Cornelius, and even then only to the extent of scheduled straight time labor to repair or replace the defective part and travel time to destination (\$40 per claim maximum). Such service is to be performed by a service agency authorized by Cornelius. Time and rate schedules for labor compensation will be published periodically by Cornelius. Additional expenses including, but not limited to truck charges, overtime charges, material costs, are not the responsibility of and will not be paid by Cornelius. Neither any part alleged to be defective and covered by this warranty or the product in which it is included shall be returned to Cornelius without authorization from the Cornelius Service Department. The instructions for return will be given with any such authorization. All returned parts and/or Products must be shipped prepaid to Cornelius. Return shipping costs of repaired or replacement parts or Products will be prepaid by Cornelius, except that as to original purchasers in Alaska or Hawaii, Cornelius will pay shipping cost only to Seattle or San Francisco, respectively. Cornelius will not accept collect shipments. Replaced products or parts become property of Cornelius. Any product or parts returned to Cornelius under the terms of this Warranty must be accompanied by a Returned Goods Authorization Number.

THE SOLE AND EXCLUSIVE REMEDIES FOR BREACH OF ANY OBLIGATION OF CORNELIUS AND THE SOLE REMEDIES FOR CORNELIUS' LIABILITY OF ANY KIND (INCLUDING LIABILITY FOR NEGLIGENCE) WITH RESPECT TO THE PRODUCTS AND RELATED SERVICES SHALL BE THE REMEDY SET FORTH HEREIN, OR IF NO SUCH REMEDY APPLIES, THEN TO USE REASONABLE EFFORTS TO PROMPTLY CURE SUCH BREACH.

IN NO EVENT SHALL CORNELIUS' LIABILITY OF ANY KIND INCLUDE ANY SPECIAL, INDIRECT, PUNITIVE, INCIDENTAL OR CONSEQUENTIAL LOSS OR DAMAGE, EVEN IF CORNELIUS SHALL HAVE BEEN ADVISED OF THE POSSIBILITY OF SUCH POTENTIAL LOSS OR DAMAGE.

CORNELIUS CUMULATIVE LIABILITY FOR DAMAGES UNDER OR IN RELATION TO A PRODUCT AND RELATED SERVICES FOR ANY CAUSE WHATSOEVER, AND REGARDLESS OF THE FORM OF ACTION; WHETHER IN CONTRACT OR IN TORT INCLUDING NEGLIGENCE, SHALL BE LIMITED TO THE COST OF SUCH PRODUCT.

No alteration or modification of the terms and conditions of this Warranty shall be valid unless expressly agreed to in writing by Cornelius. Any different, additional, or conflicting terms or condition set forth in any order confirmation of other writing are expressly objected to by Cornelius and the terms of this Warranty shall exclusively govern warranties and remedies with respect to the Products.

IMI CORNELIUS
www.cornelius.com

Automated Beverage System

INTRODUCTION

The Automated Beverage System (A.B.S.) is an automated cold beverage dispenser for drive-thru applications. When a cold beverage is ordered from the P.O.S. register, the A.B.S. will automatically drop the cup, fill it with ice, and dispense the correct amount and type of any syrup-based cold beverage. The finished drink is then moved by the conveyor to the pick-up station and the drink description is displayed on the panel.

The Automated Beverage System has three modes of operation:

- **Automatic Mode**

In automatic mode, the customer places an order at the drive-thru and the A.B.S. automatically produces the order. If extra or no ice drinks are ordered, they are entered from the P.O.S. as a “grill order” and the A.B.S. automatically produces the drink as ordered.

- **Semiautomatic Mode**

While in automatic mode, the operator presses the desired cup size button, the desired flavor button and ENTER, then the drink is dispensed. If extra ice or no ice is required, the EXTRA ICE or NO ICE button is pressed after the flavor button has been pressed before ENTER, then the drink is dispensed.

- **Manual Mode**

A drink can also be dispensed in manual mode. Remove the conveyor. Enter the manual mode by pressing the Manual/Auto button. (Don't pull cups from A.B.S. Turret damage may occur to cup tubes.) Locate a sleeve of cups and remove a cup. Hold the cup under the ice chute, press EXTRA ICE and ice is dispensed. Hold the cup under the nozzle, press and hold the desired flavor button, and the drink is dispensed. Reinstall the conveyor and return the A.B.S. unit to normal operation.

SAFETY

To avoid possible fatal electrical shock or serious injury to the Operator, it is highly recommended that a G.F.I. (ground fault circuit interrupter) be installed in the electrical power circuits to the unit.

Always disconnect power before cleaning or servicing the unit. Do not use metal scrapers, sharp objects or abrasives on the ice storage hopper, top cover and the agitator disk, as damage may result.

Always disconnect CO2 or air pressure to the unit before cleaning or servicing the grabber arm or ice chute. A disconnect switch for the ice gate is located on the control box behind the cup lid holder panel.

Insure that the unit is in manual mode before removing or replacing the conveyor assembly to avoid pinching fingers in the drain area.

The dispenser is very top heavy. To prevent serious injury, exercise caution when moving or setting the dispenser in place.

Automated Beverage System

Illustrated Parts List

A.B.S. Unit Access

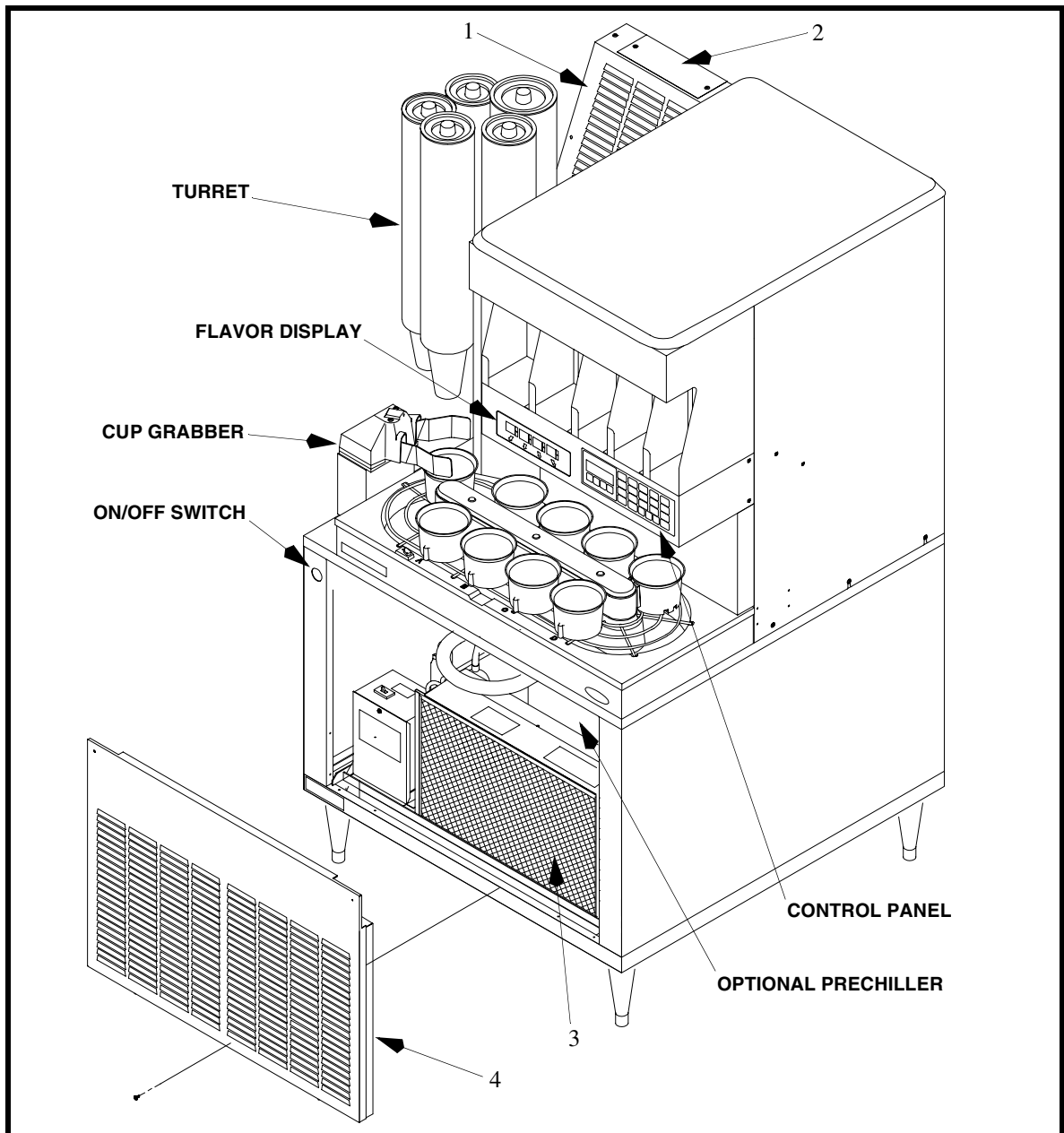

Automated Beverage System –Assembled Unit Diagram

Ref Number	CCUSA Number	MFG. Number	Description
1		560000260	Ventilation Grill
2		560000245	Access Hole Cover
3		560000291	Air Filter
4		560000289	Front Panel (Built before Serial No. 56A0019AB102)
		560002774	Front Panel (Serial No. 56A0019AB102 and after)

Automated Beverage System

Illustrated Parts List Conveyor Assembly

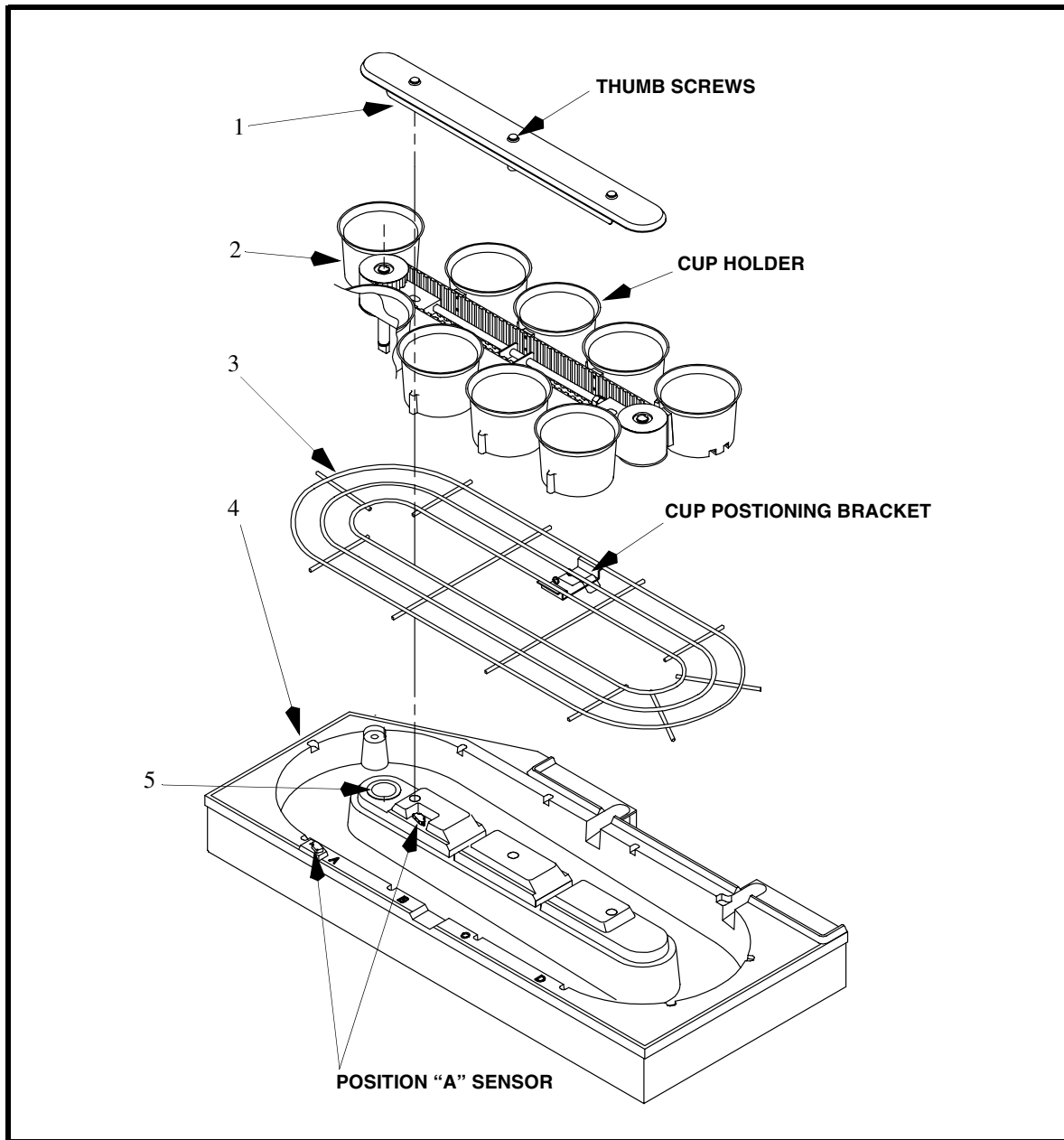

Automated Beverage System –Conveyor/Cup Rest Assembly Diagram

Ref Number	CCUSA Number	MFG. Number	Description
1	27921	560000320	Conveyor Cover
2	27922	569000295	Conveyor Assembly
3		560000315	Cup Rest
4		560000306	Drip Tray Assembly
5	20669	560002714	Water Deflector

Automated Beverage System

Illustrated Parts List Ice Chute Assembly

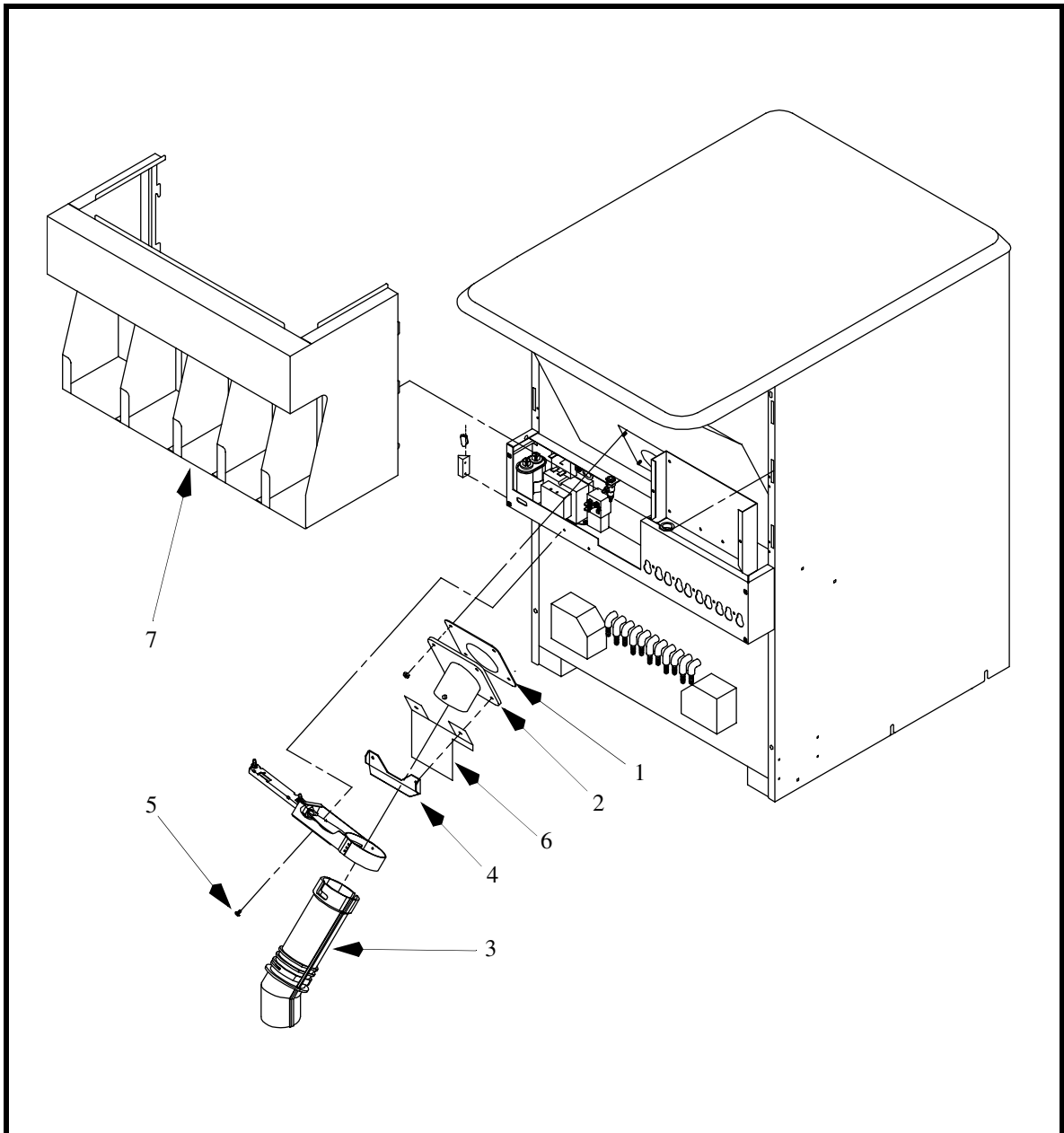

Automated Beverage System –Ice Chute Assembly Components Diagram

Ref Number	CCUSA Number	MFG. Number	Description
1		560000392	Ice Chute Gasket
2		560000344	Ice Chute Mounting Plate
3	27926	560000346	Ice Chute
4		560002728	Ice Chute Stiffener
5		560000398	Machine Screw, Phillips Truss Head, No. 8 x .5"
6		560001548	Ice Chute Shield
7		620014801	Lid Holder Assembly
8	28076	560001589	Ice Chute Cleaning Brush (Not Shown)

Automated Beverage System

Illustrated Parts List Cup Tube Assembly

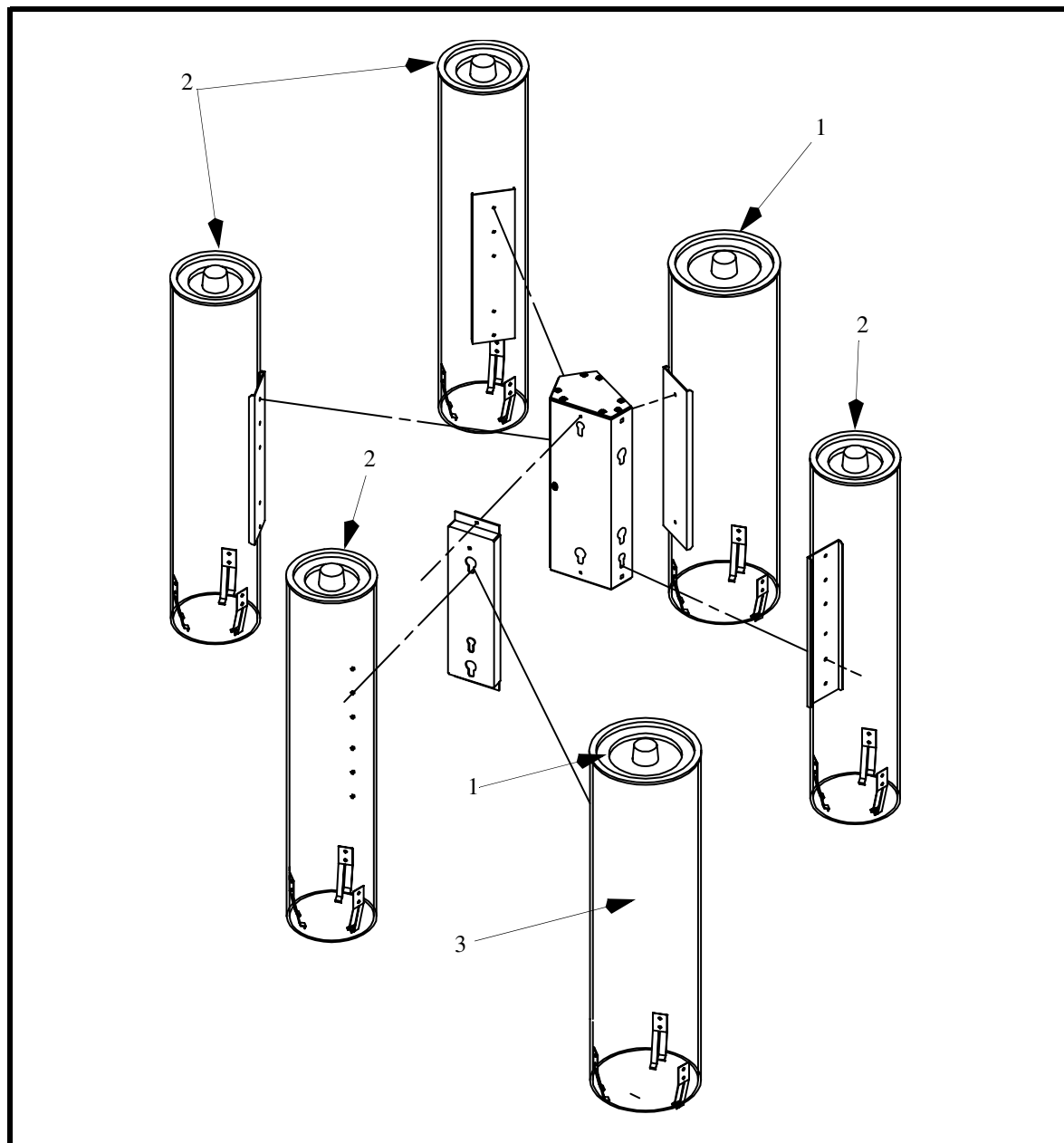

Automated Beverage System –Cup Tube Components Diagram

Ref Number	CCUSA Number	MFG. Number	Description
1	27916	560000207	5" Cup Tube Cover (32 - 42 oz.)
2	27915	560000206	4" Cup Tube Cover (12 - 21 oz.)
3	28377	569000199	42 Oz. Cup Tube Kit
N/R	28373	569000172	12 Oz. Cup Tube Assembly Kit (Australian "Small" size)
N/R	28374	569000173	16 Oz. Cup Tube Assembly Kit (Australian "Medium" size, station 3)
N/R	28375	569000174	21 Oz. Cup Tube Assembly Kit (Australian "Large" size, station 1)
N/R		569000175	32 Oz. Cup Tube Assembly Kit
N/R		569000159	21 Oz. Cup Tube Assembly Kit (Australian "Large" size, station 2)
N/R		569030035	Medium Cup Tube Assembly Kit Station 5, (Australian ABS only)

Automated Beverage System

Illustrated Parts List Agitator Assembly

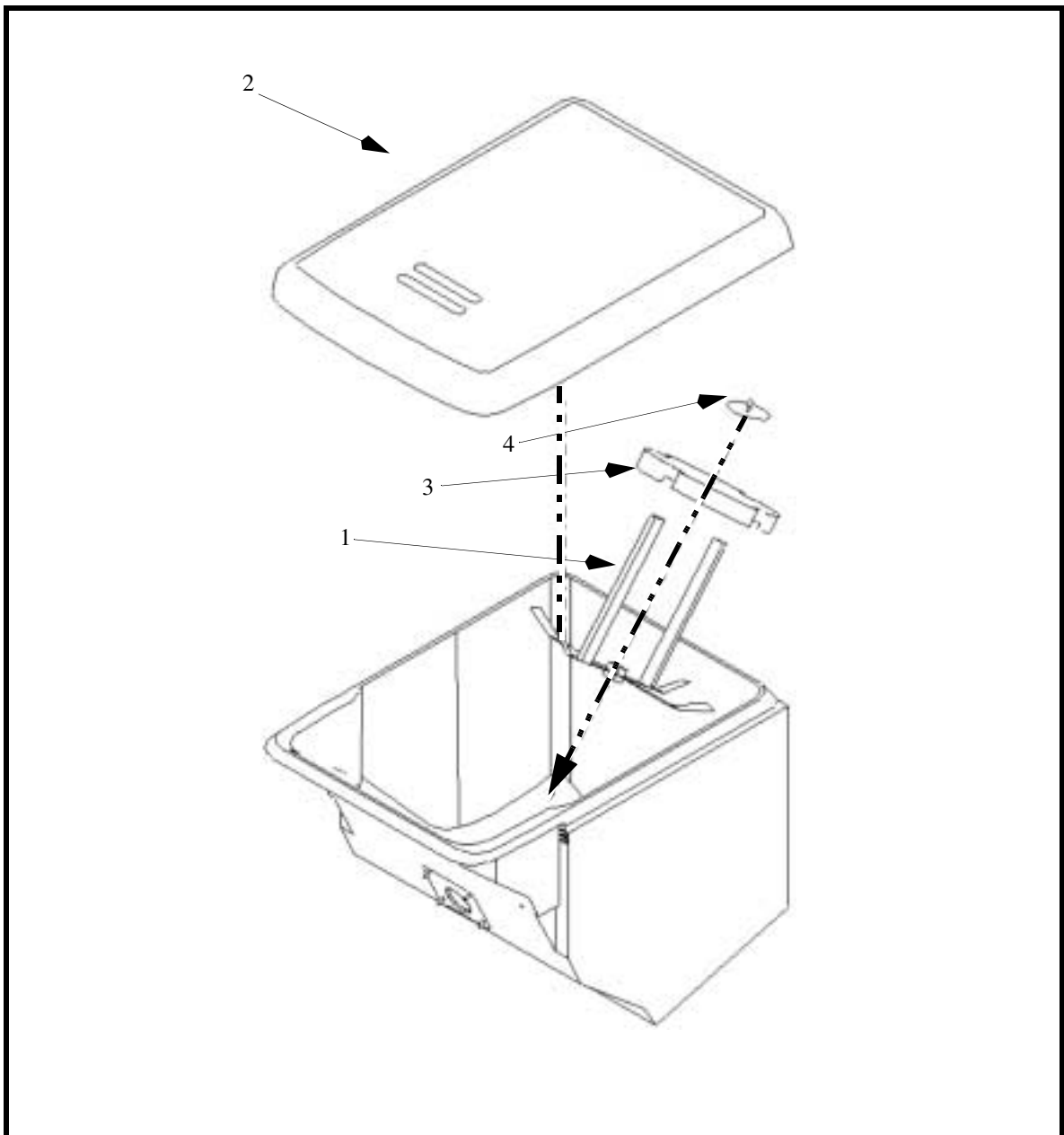

Automated Beverage System –Ice Bin Components Diagram

Ref Number	CCUSA Number	MFG. Number	Description
1	15346		Agitator Assembly
2	52887		Lid
3	53227		Disk
4	15087		Agitator Retainer

Automated Beverage System

Illustrated Parts List

Nozzle Assembly

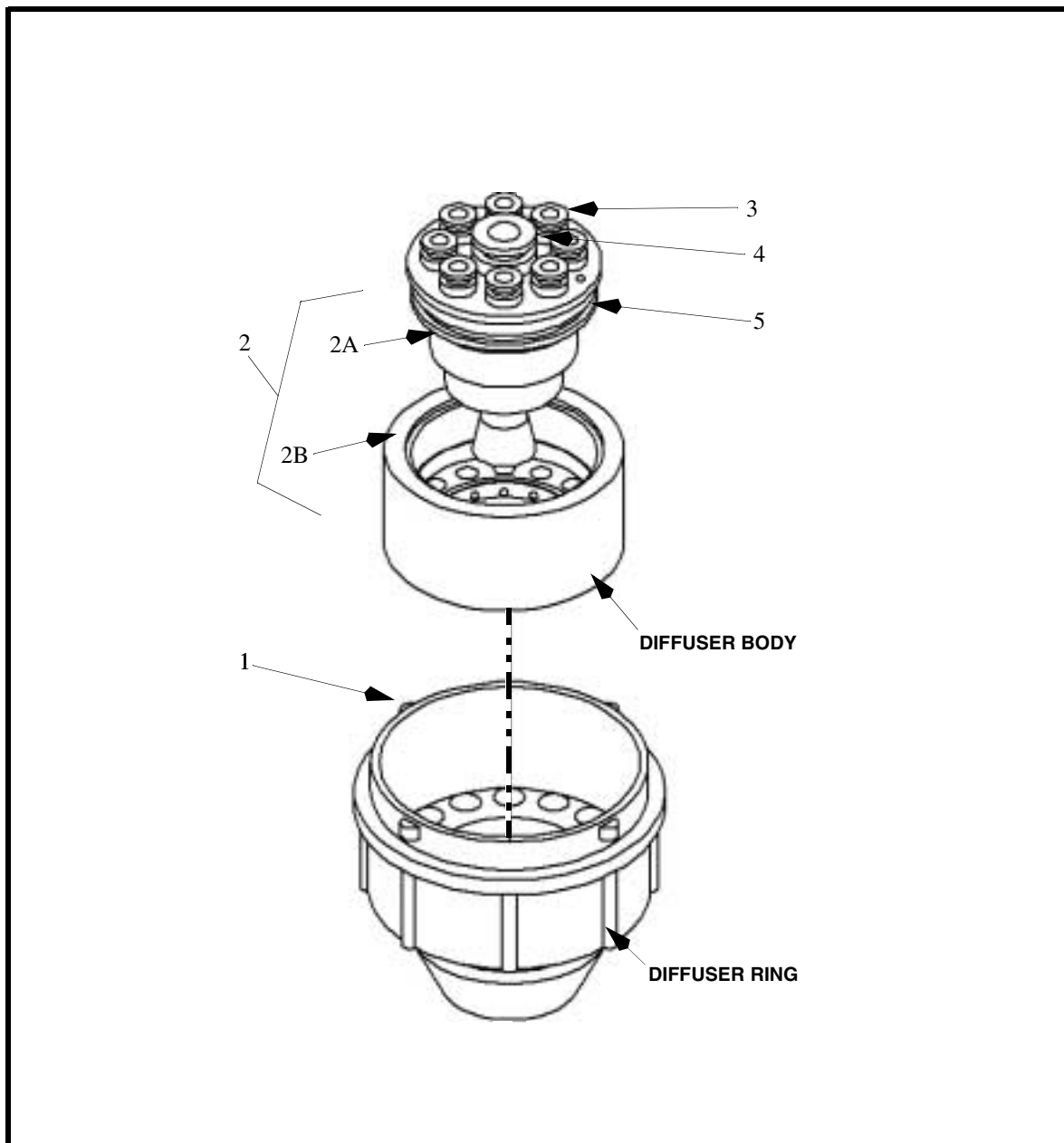

Automated Beverage System –Nozzle Assembly Components Diagram

Ref Number	CCUSA Number	MFG. Number	Description
.....		161509	Complete Assembly
1.....	27940	560001545	Nozzle
2.....	27939	560001544	Diffuser
3.....		110677000	O-Ring
6.....		325216000	Nozzle Brush (Not Shown)

Automated Beverage System

Fully Automatic Operation

Operational Modes

The A.B.S. has three modes of operation:

- Automatic (Normal Operation)
- Semi-Automatic (while in Auto)
- Manual

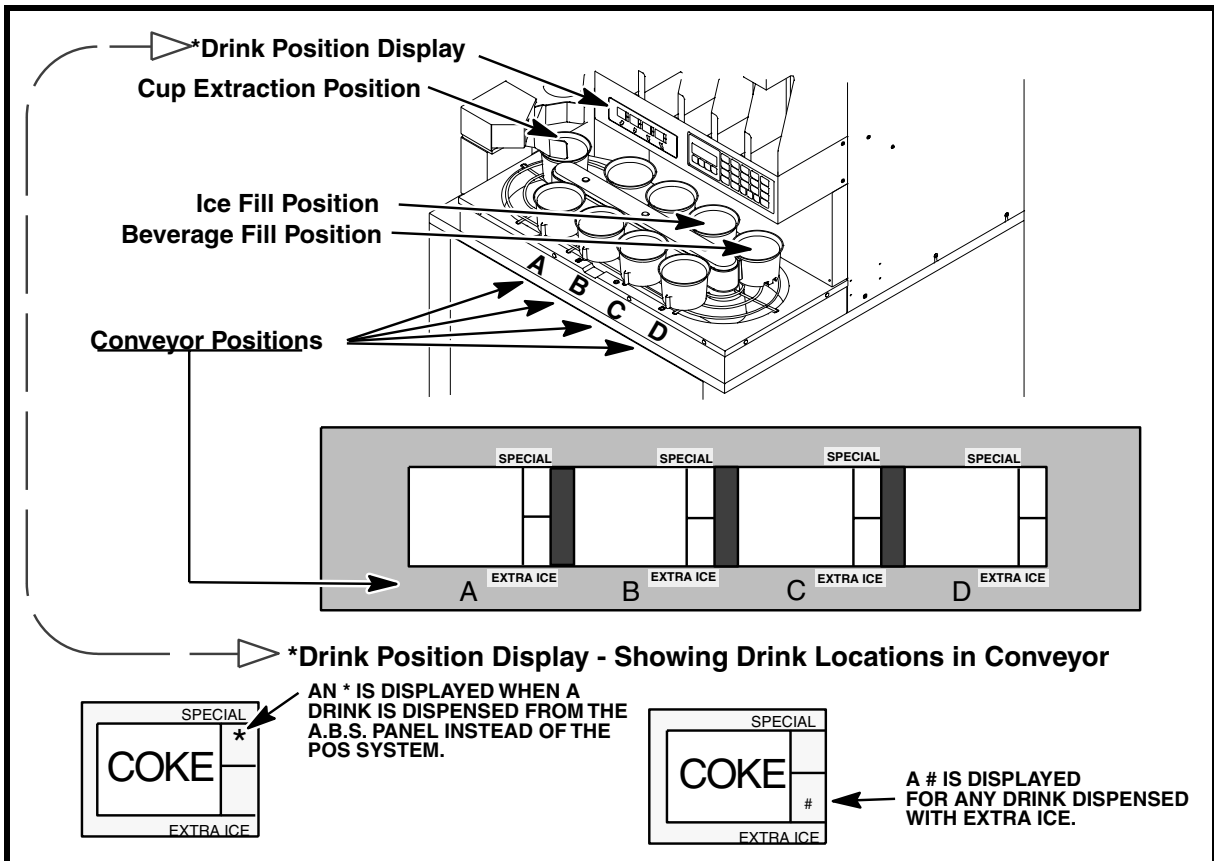
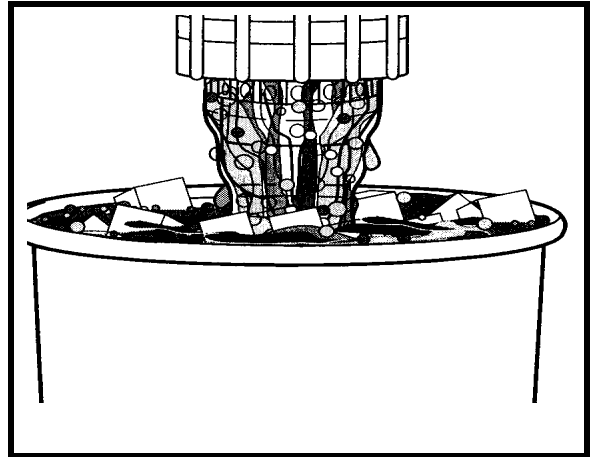

Location Diagram

Automated Beverage System

Automatic Operation



Order Entered On P.O.S.

With the unit in automatic mode, the customer places an order at the Drive-Thru.

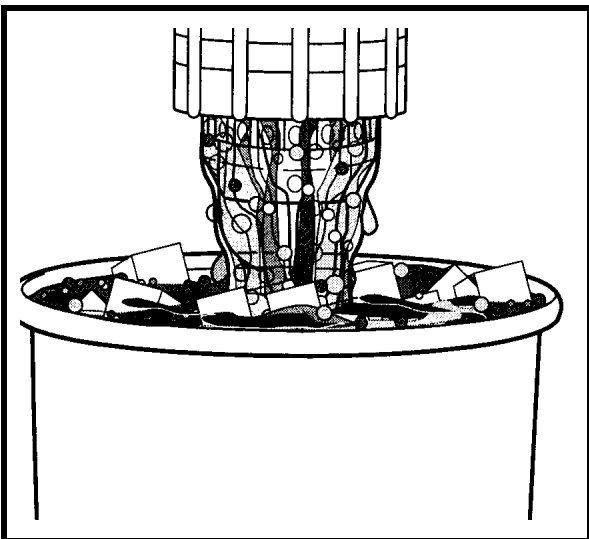

Special Ice Drinks

Extra and no ice drinks are entered from the P.O.S. as a “grill order.” The A.B.S. will automatically produce the drink to the special order.

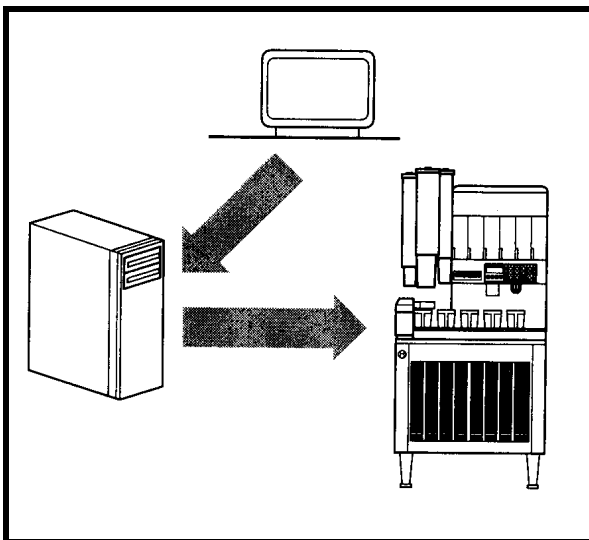

P.O.S. Signal To Manager's Computer

The order is transmitted from the P.O.S. to the store computer and from there to the A.B.S. unit.

Automated Beverage System

Automatic Operation

Cup Turret Rotates

The cup turret rotates to move the proper size cut to the extract position.

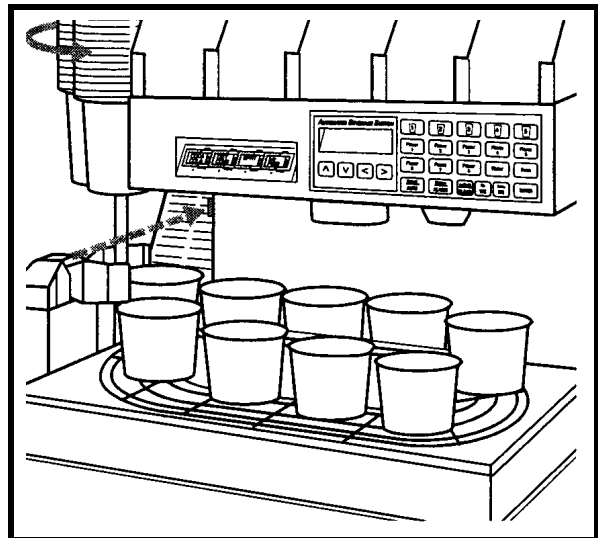

Cup Grabber Rises & Closes

The cup grabber is lifted by a pneumatic cylinder up to the cup. The travel is sensed by the full travel sensor. If full height is reached, a pneumatic cylinder closes the grabber arms against the cup. A sensor detects if cups are available.

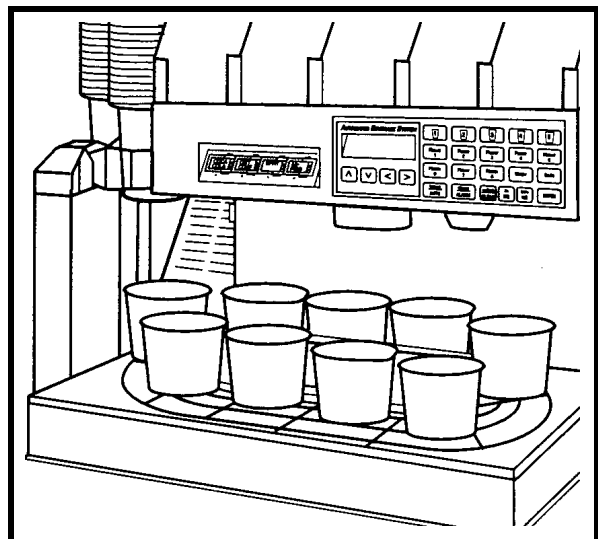

Grabber Lowers & Opens

The cup grabber lowers, pulling the cup from the cup tube and then the arms open dropping the cup into the conveyor.

If the grabber should slide off a cup, it would be detected by the cup sensor.

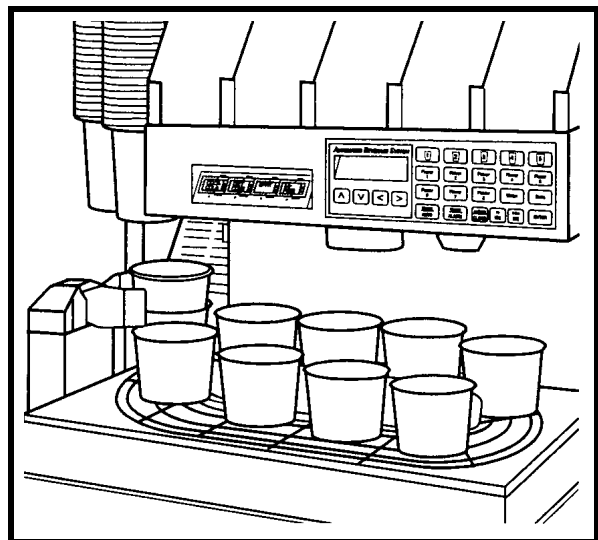

Automated Beverage System

Automatic Operation

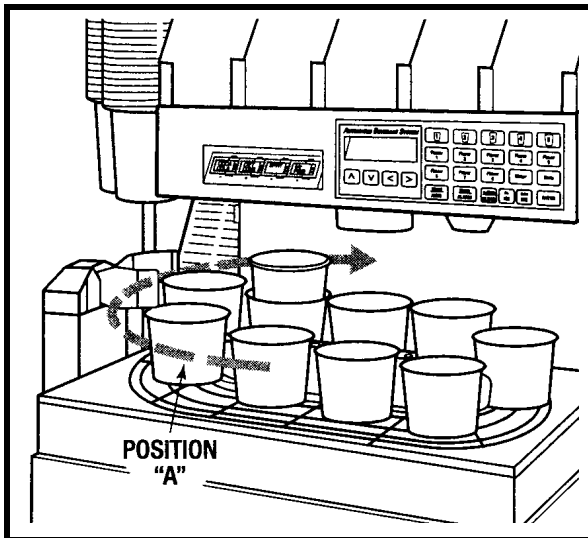

Conveyor Operates

Sensors check for a cup in position "A." If the sensor is clear, the conveyor rotates clockwise to move the cup to the ice chute.

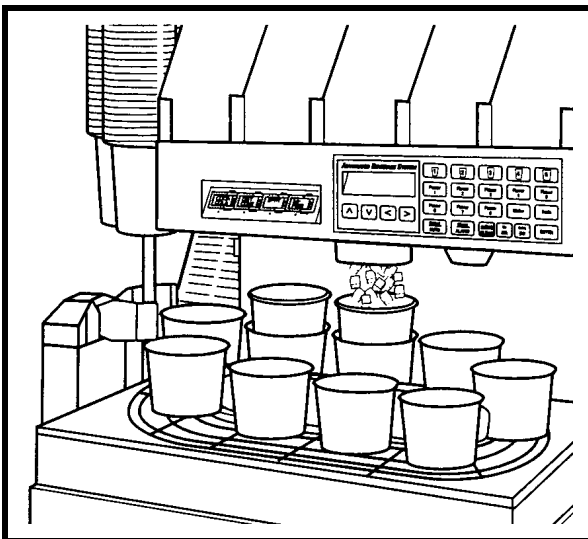

This is based on only one drink being ordered. If a second drink had been ordered, the conveyor would have moved only one position and the second cup would have been extracted and dropped into the conveyor. The two cups would then be moved clockwise until the first cup reaches the ice fill port.

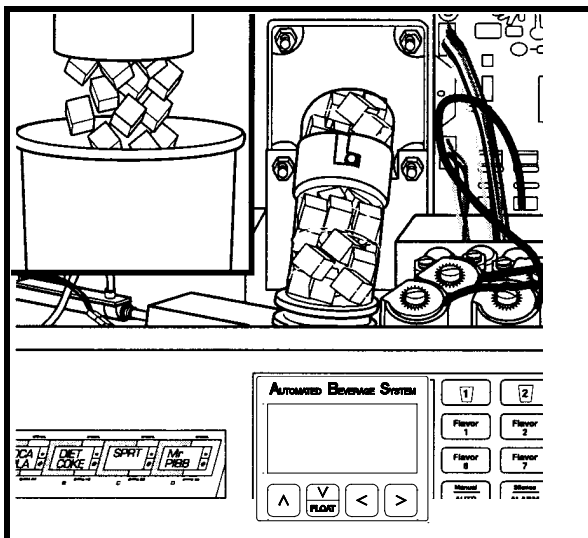

Ice Portion Is Dispensed

The ice gate is opened by a pneumatic cylinder for the time needed to dispense the selected ice portion. Correct operation is insured by the ice gate full travel sensor.

The agitator continues to operate for the set refill time to refill the ice chute.

Automated Beverage System

Automatic Operation

Cup To Dispensing Nozzle

Sensors check for a cup in position A. If the sensor is clear, the conveyor moves the cup to the beverage fill point. The valve opens to dispense the desired syrup and water in the desired portions into the cup.

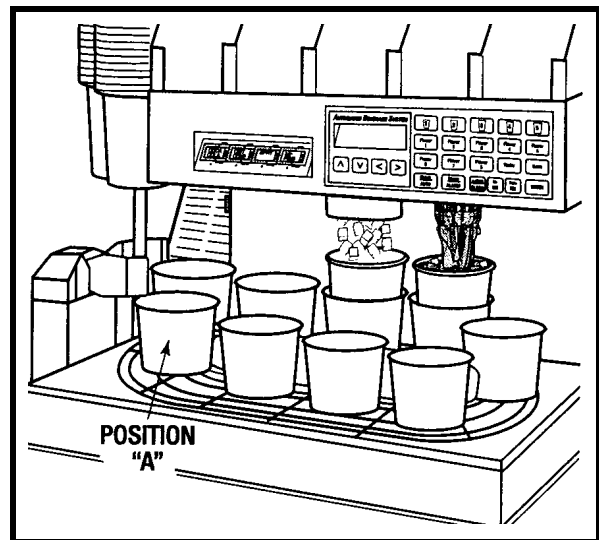

Beverage Dispensed

The computer sends the drink portion of the order to the A.B.S. where the information is interpreted and the drink is dispensed.

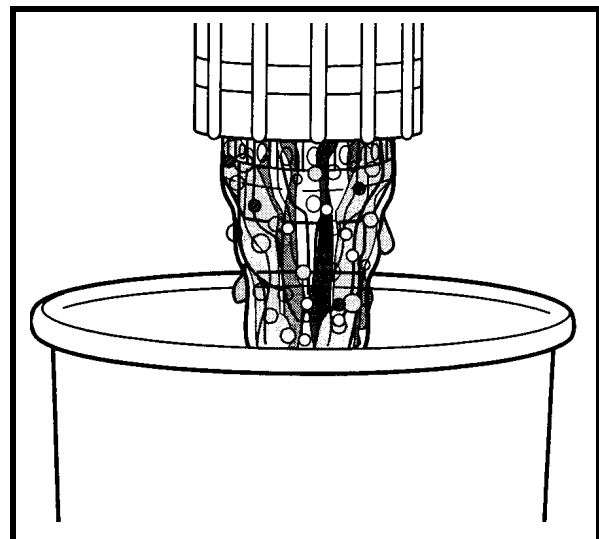

If the drink requires a top-off, the initial portion will be dispensed. After a delay, the balance of the drink will be dispensed.

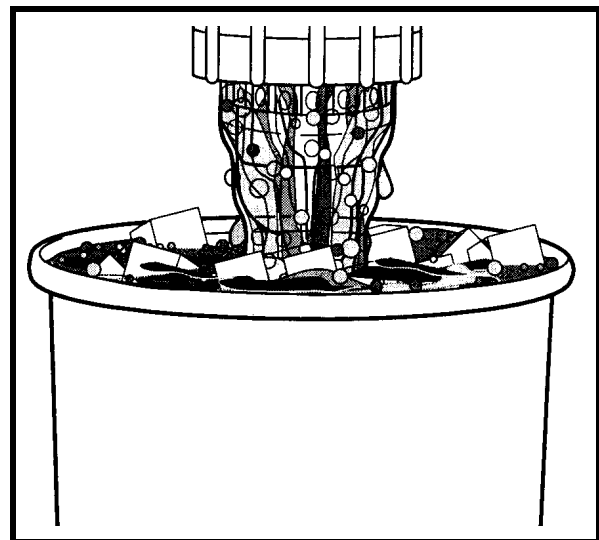

Automated Beverage System

Automatic Operation

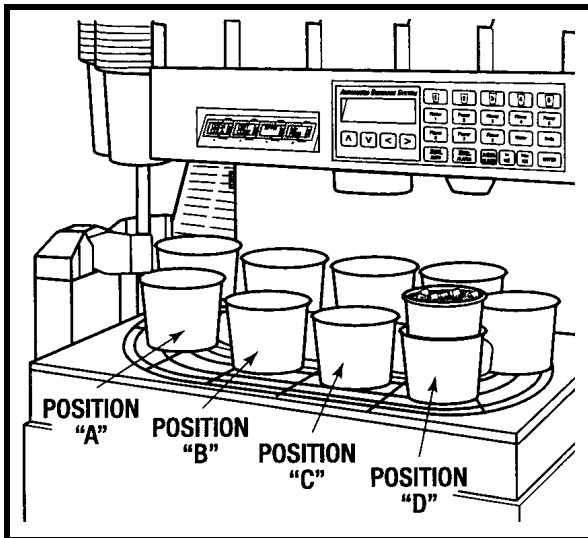

Cup Is Moved To Cup Serve Point

Sensors check for a cup in position "A." If the sensor is clear, the conveyor moves the cup to cup serve position "D."

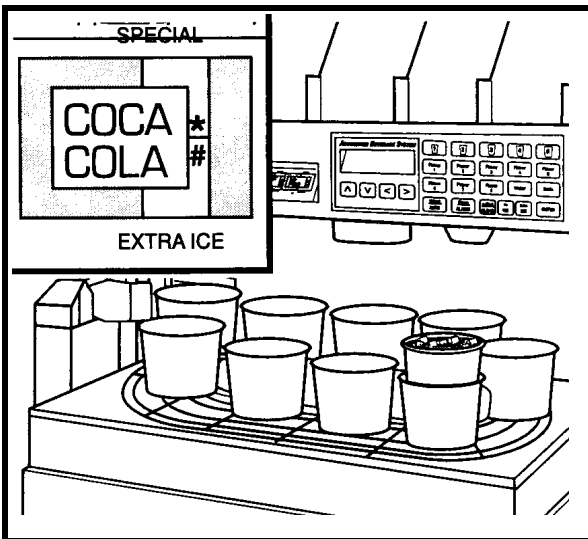

The display will indicate the flavor of the beverage at cup serve position "D."

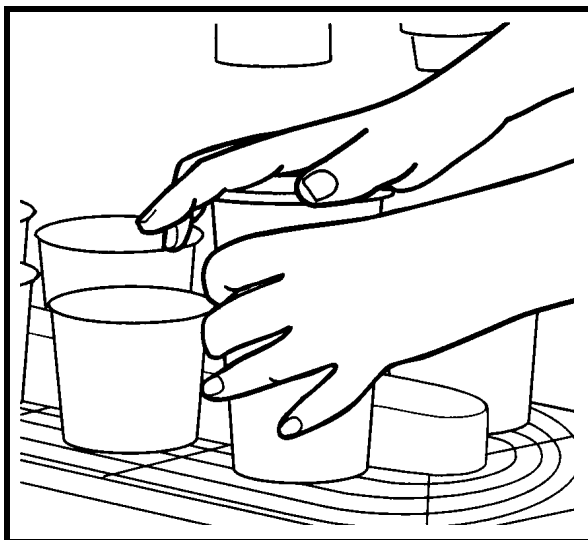

Crew Member Serves Drink

A crew member caps the drink while still on the conveyor and serves it with the remainder of the order.

Automated Beverage System

Semiautomatic Operation (Unit in Automatic)

Press Cup Size

While in automatic mode, to dispense a drink in the semi-automatically, press the desired cup size button.

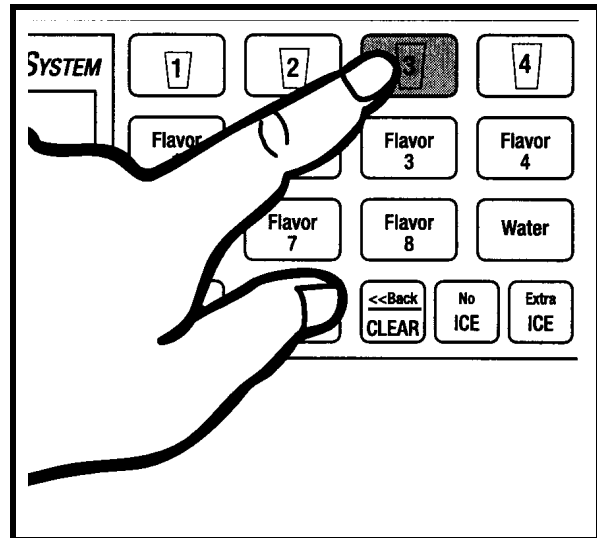

Press Flavor

Press the desired flavor button.

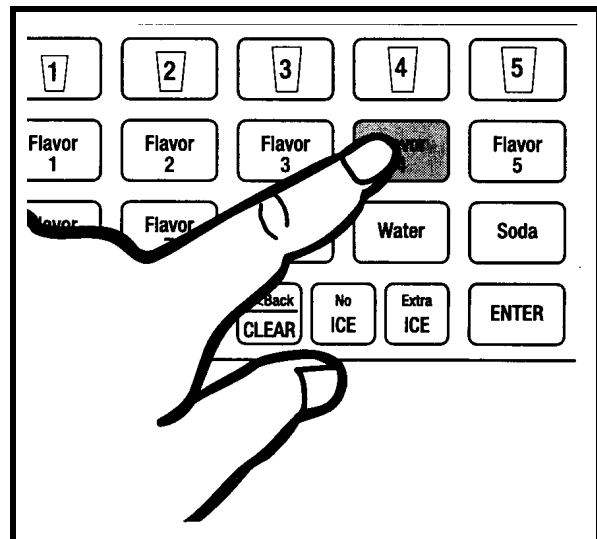

Press Special Ice Requirement If Requested

If extra ice is desired, press the EXTRA ICE button. If no ice is required, press the NO ICE button.

If normal ice is desired, no button is pressed.

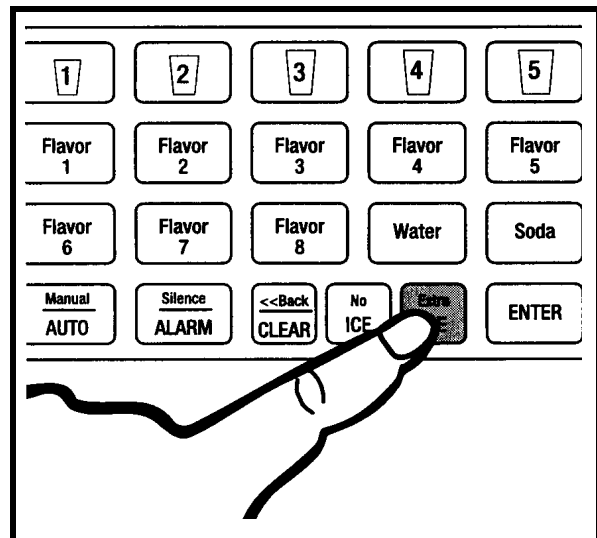

Automated Beverage System

Semiautomatic Operation (Unit in Automatic)

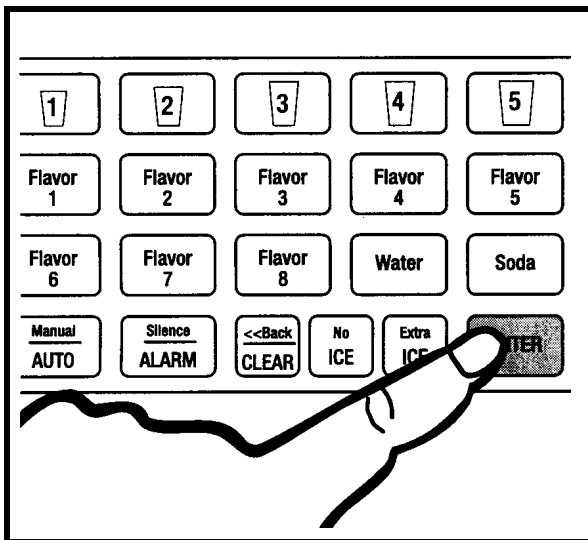

When Correct, Press Enter

Sequence of pressing the cup size, flavor, and special ice buttons is not important. At any time, pressing any button will change the selection of the drink to be dispensed. When the correct order is displayed, press ENTER and the drink will be dispensed.

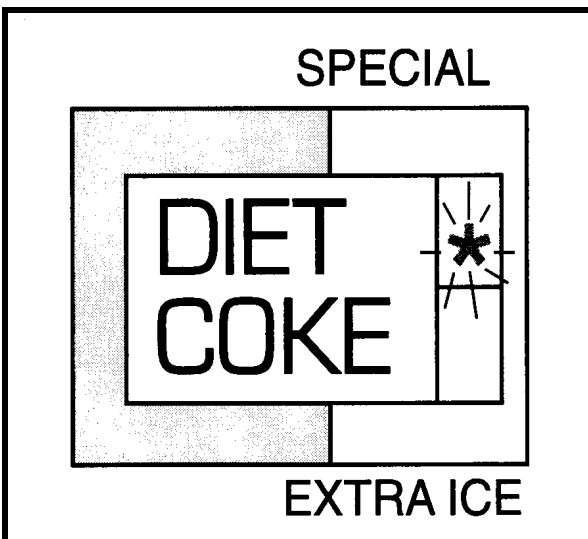

Any drink entered in this manner will display an illuminated asterisk in the SPECIAL section of the Drink Position Display identifying the semiautomatic drink selected at the A.B.S. panel.

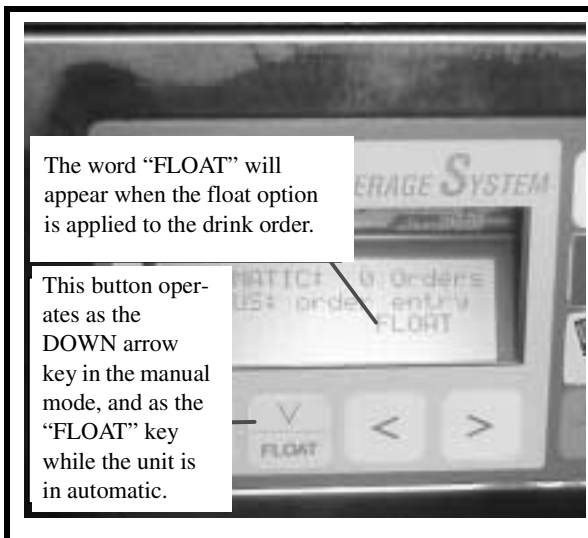

ABS Float Dispensing

ABS Float Dispensing allows for the ABS to dispense drinks, without ice, that are only a pre-set portion full. Ice cream can then be added after the dispense, to make it into a "FLOAT" drink.

Ordering a Float Drink

1. Place the unit in AUTOMATIC MODE
2. Select the CUP SIZE
3. Select the FLAVOR
4. Press the DOWN ARROW/FLOAT KEY
5. Press ENTER

Automated Beverage System

Manual Operation

Enter Manual Mode

Enter the manual mode by pressing the Manual/AUTO button.

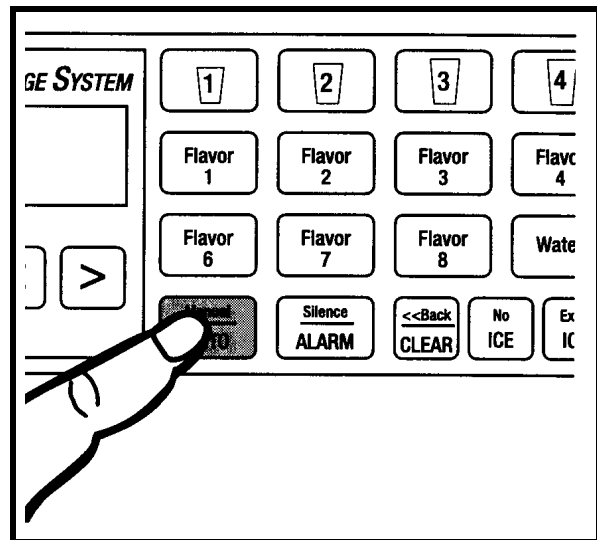

Remove The Conveyor

To dispense a drink in the manual mode, remove the conveyor. This is done by removing the thumb screws holding it in place and lifting the conveyor up.

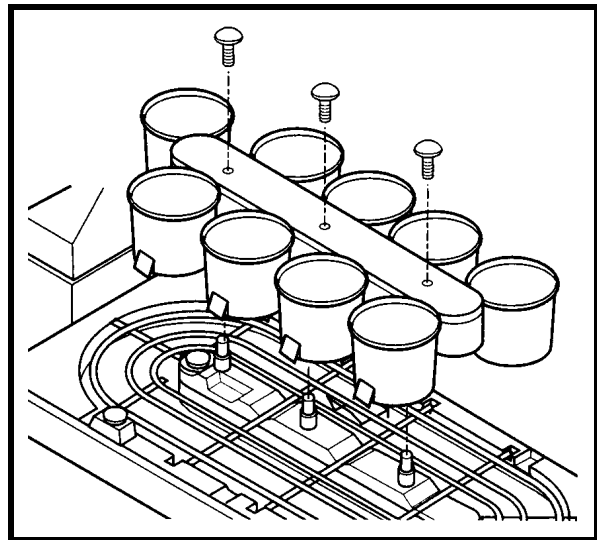

Never Remove Cups From Cup Turret Assembly

Manually pulling cups from the cup tubes can permanently damage the retainers.

Stock cup sleeves near the unit when in manual mode.

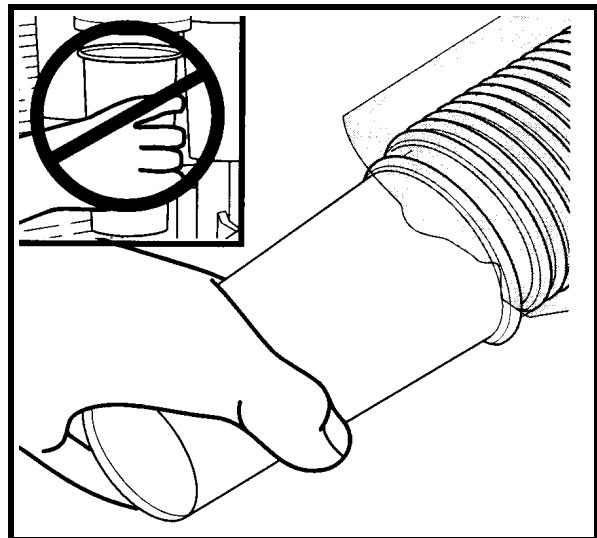

Automated Beverage System

Manual Operation

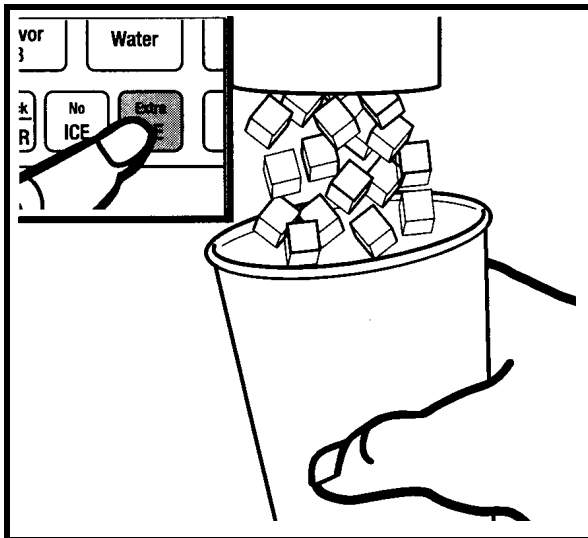

Dispense Ice

Hold the cup under the ice chute. Dispense ice by pressing the EXTRA ICE button.

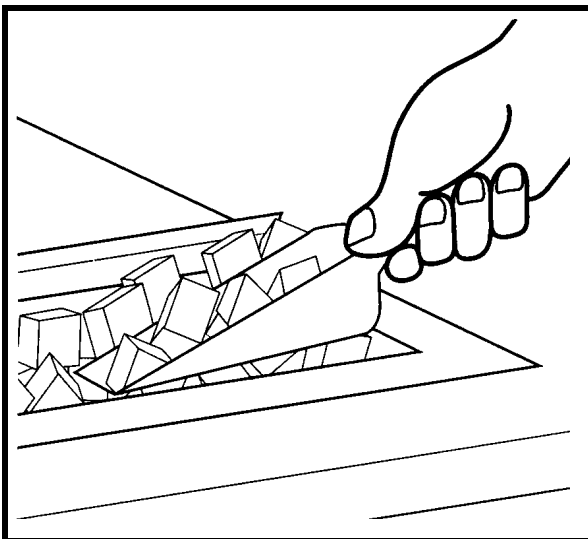

Ice Not Dispensed

If there is an issue with CO₂, ice may not dispense. In this case, locate a supply of ice near the unit for manually filling the cups.

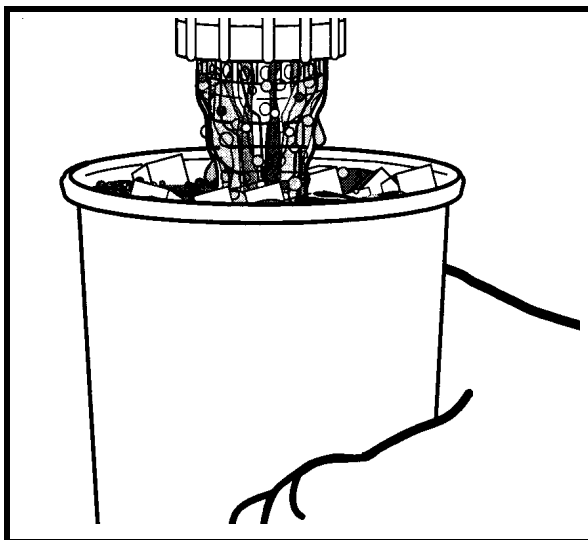

Dispense Beverage

Hold the cup under the nozzle. Press and hold the desired flavor button to dispense the beverage.

Automated Beverage System

Manual Operation

Return The A.B.S. To Normal Operation

Reinstall the cup conveyor by aligning the drive pin on the left side of the conveyor assembly so that the conveyor seats properly. The conveyor drive pin must engage the drive socket on the gear box. When installing the conveyor, it may be necessary to move the conveyor manually to allow the drive pin to insert into the drive socket.

Tighten the thumb screws on the cover.

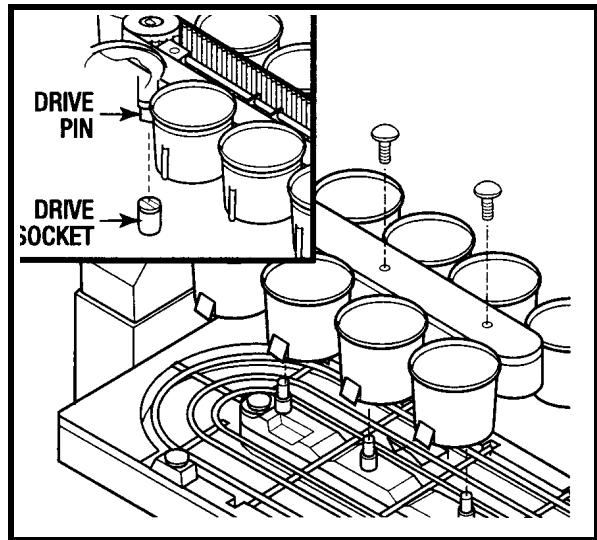

Clear The P.O.S. Order Buffer

If orders are on the screen, the P.O.S. buffer must be cleared. To clear the P.O.S. buffer, the A.B.S. unit must be in the MANUAL mode.

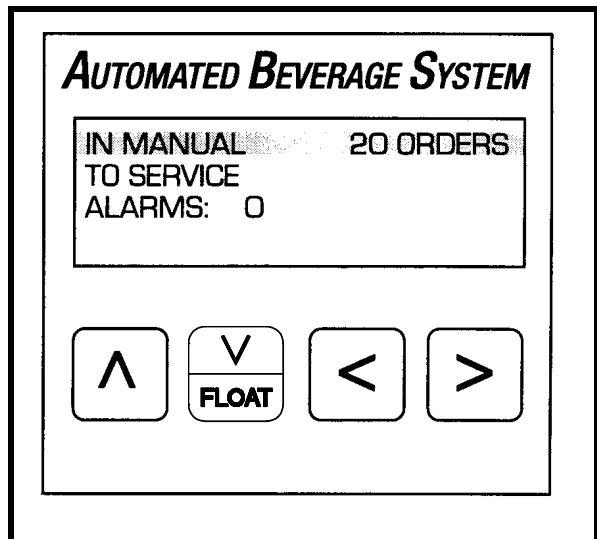

Press the UP arrow to highlight the “XXX ORDERS”.

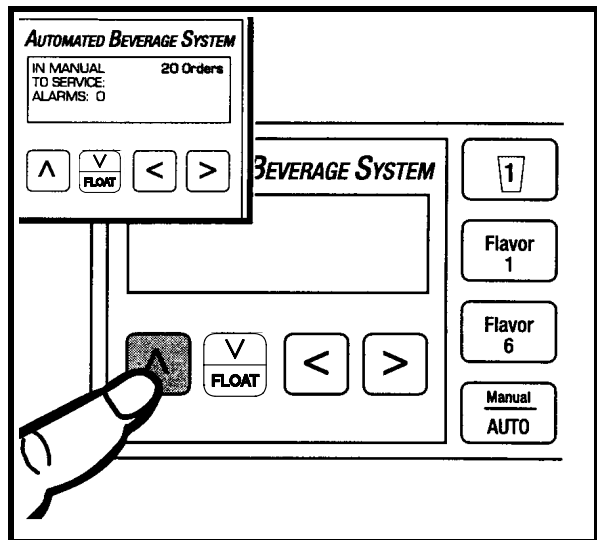

Automated Beverage System

Manual Operation

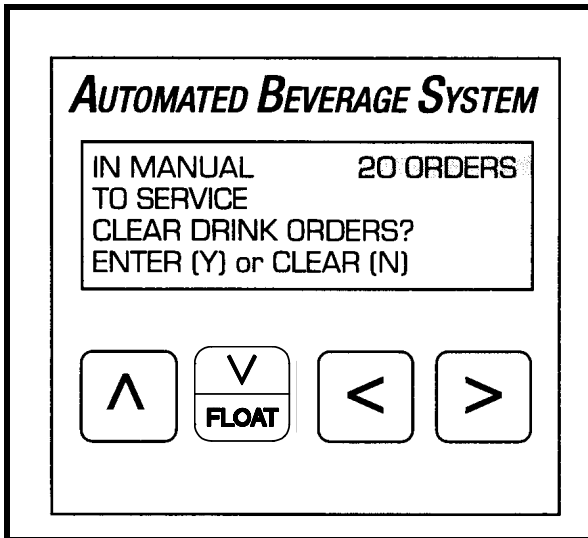

A confirmation question will appear. Press ENTER to clear the entire order buffer or CLEAR to cancel action.

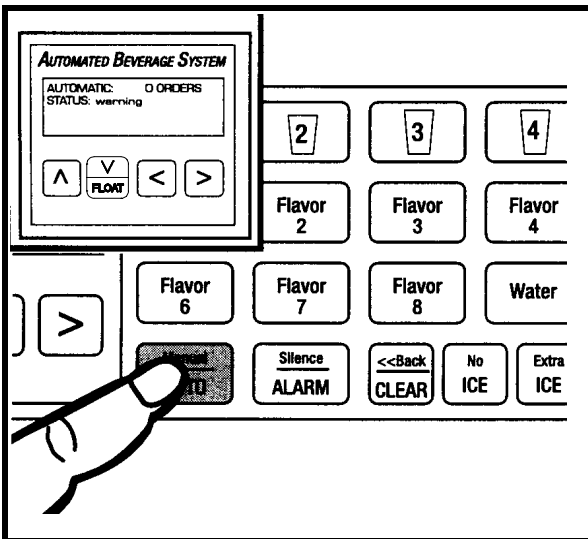

Return To Automatic Mode

Press the Manual/AUTO button to return to Automatic mode.

Automated Beverage System

Introduction to the A.B.S. Unit Major Subsystems

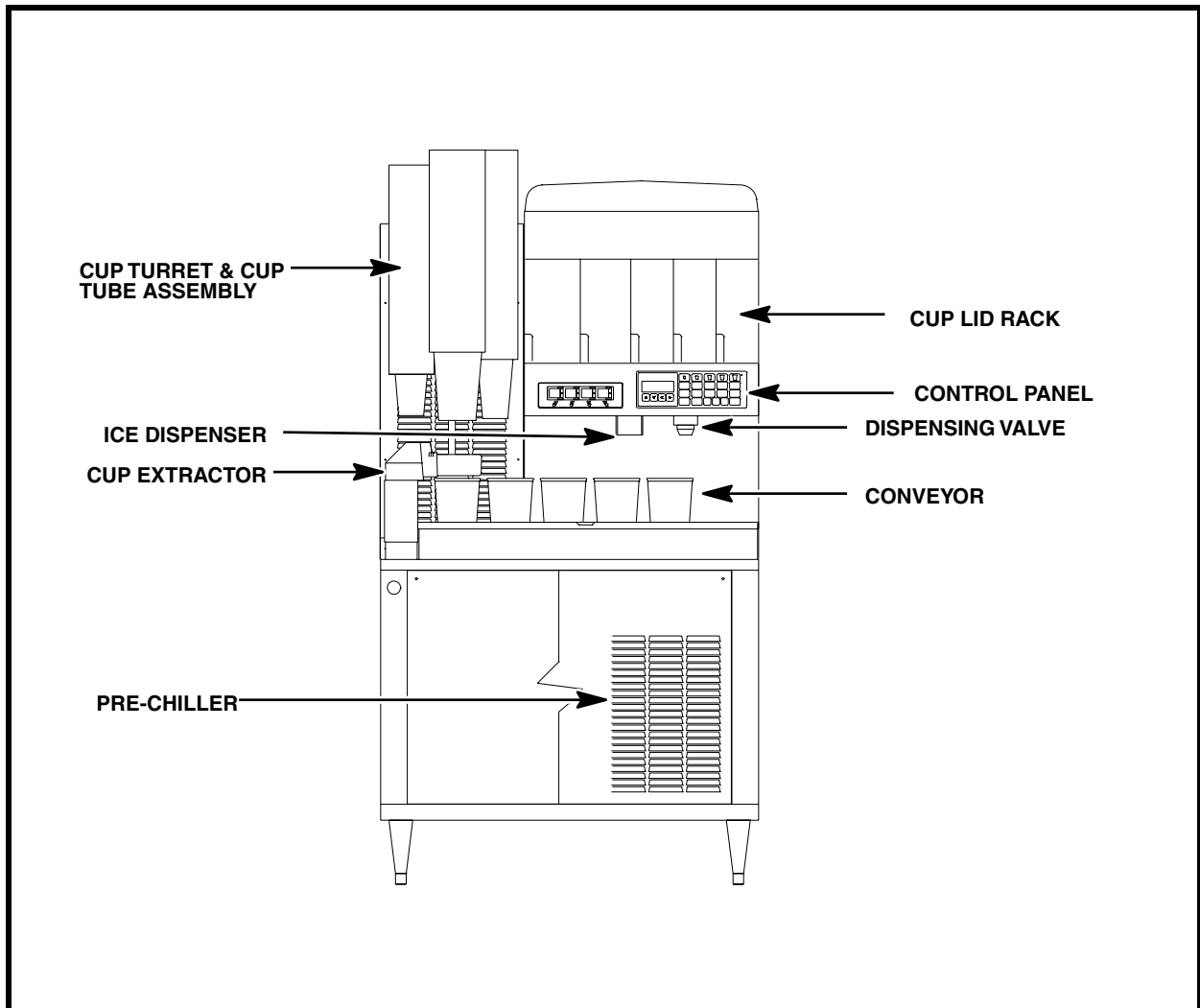

Components of the A.B.S.

- Turret
- Cup Lid Rack
- Ice Dispenser
- Control Panel
- Cup Extractor
- Conveyor
- Beverage Dispenser
- Pre-Chiller (Optional)

Automated Beverage System

A.B.S. Unit Major Subsystems Control Touch Panel

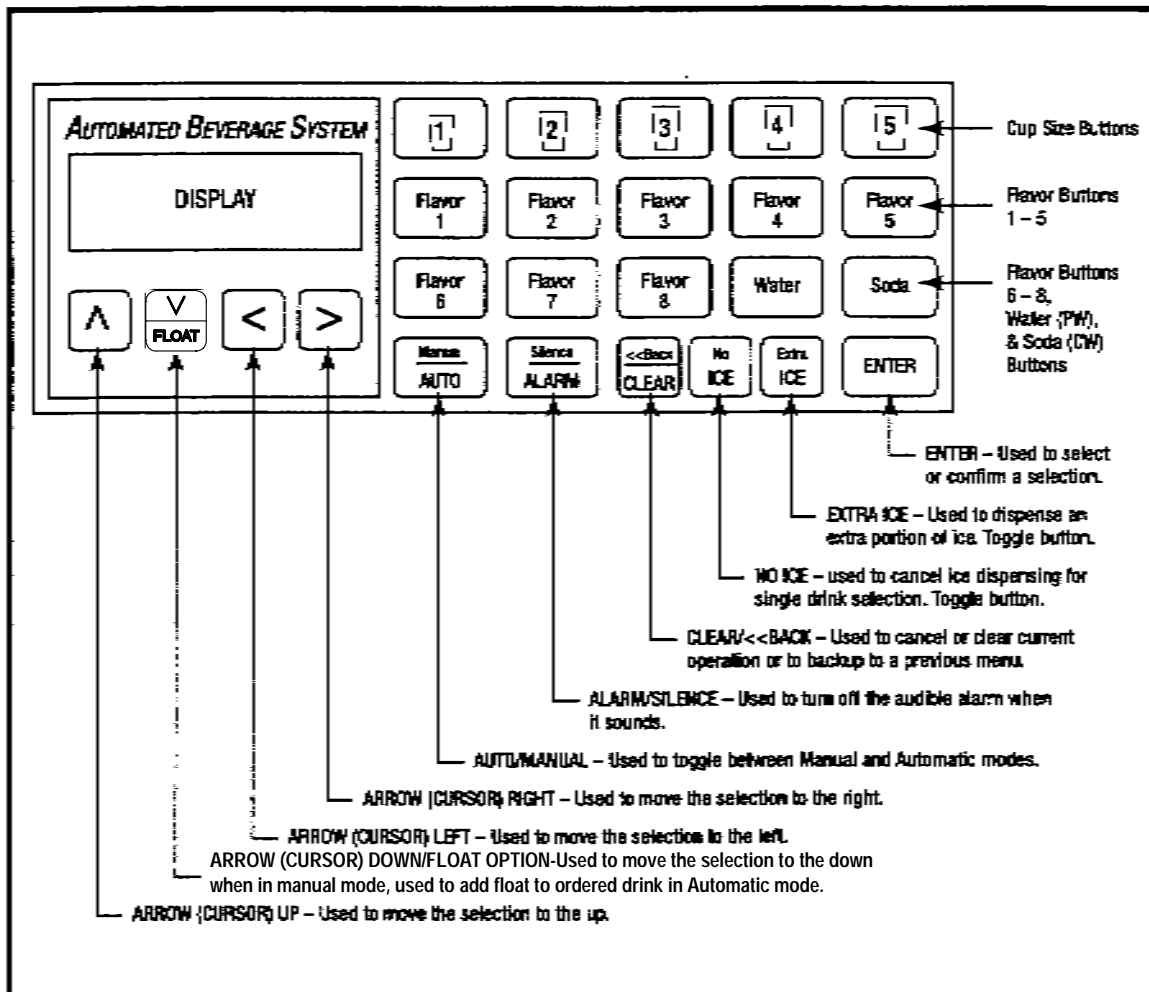

Automated Beverage System

A.B.S. Unit Major Subsystems – Control Touch Panel

Touch Panel Description

Each button on the Touch Panel is described in detail in the Touch Panel Diagram on page 24.

Whenever any button is pressed, there is an audible Beep. If the button is incorrect and cannot function, there will be a triple Beep indicating an error.

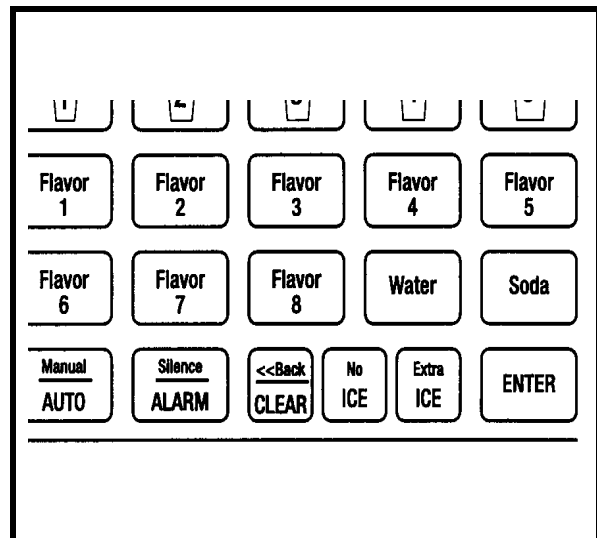

Display, Touch Panel

The display that is visible through the window in the Touch Panel is the message center for the A.B.S. The display examples shown is only one of the many messages that may be displayed.

This display shows the status, guides you through programming, tells you what errors have occurred, the number of cycles on a component and other messages.

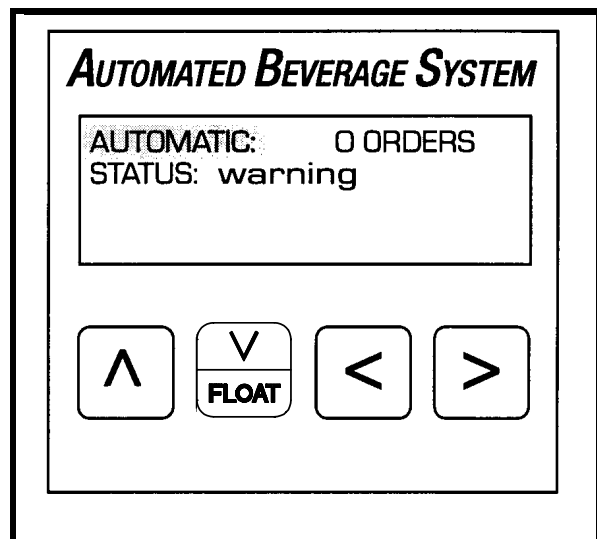

Automated Beverage System

A.B.S. Unit Major Subsystems Control Panel, Drink Position

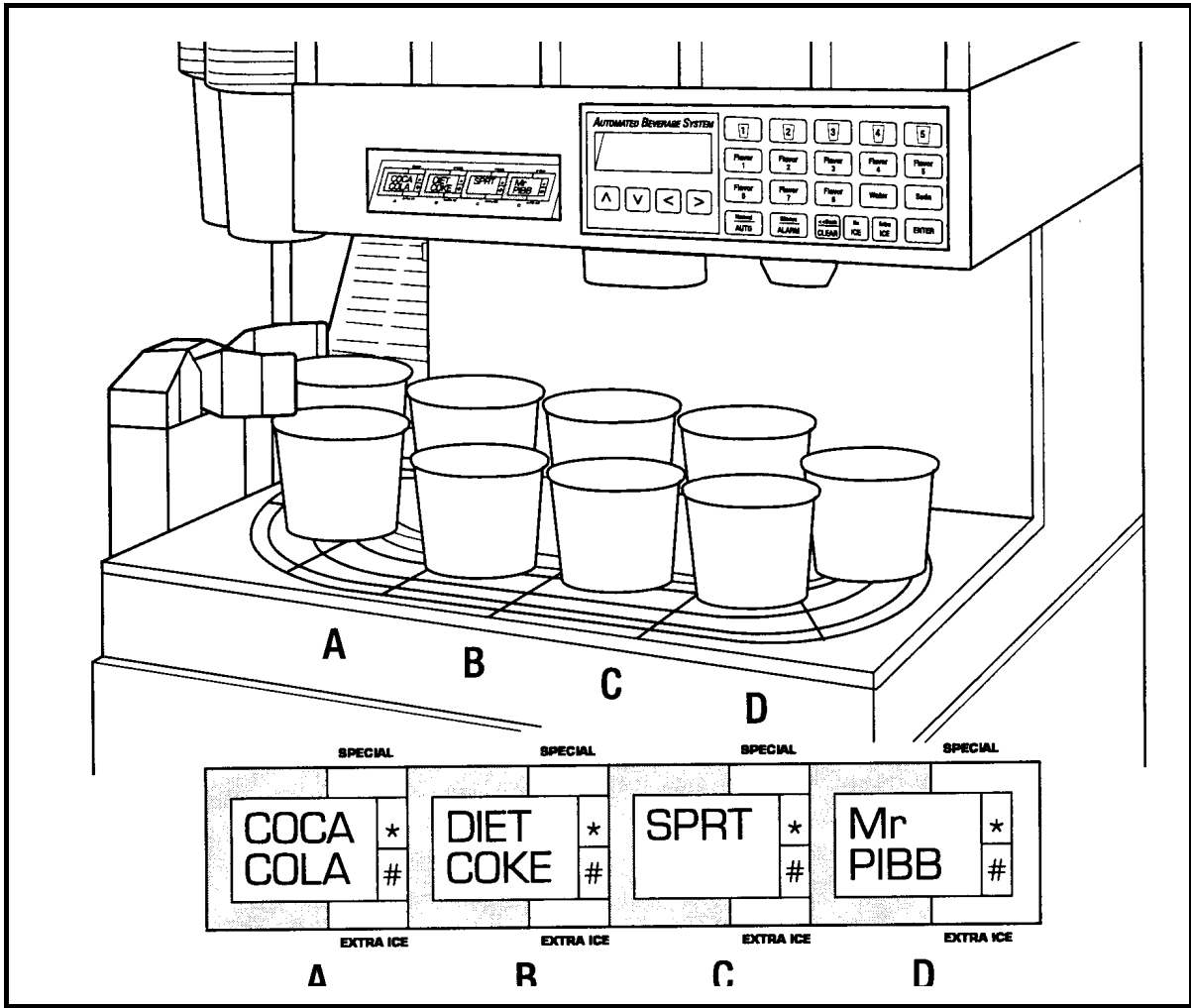

Drink Position Display

The Drink Position Display corresponds to the four drink pickup positions on the conveyor. As a drink moves to position "D" on the conveyor, the details of the drink are displayed.

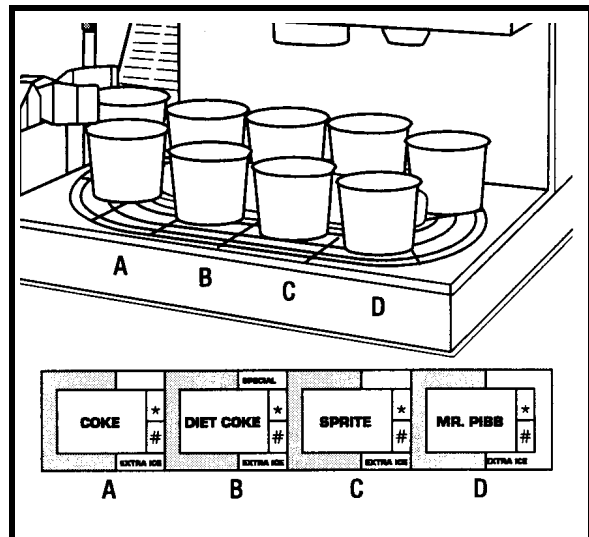

Automated Beverage System

A.B.S. Unit Major Subsystems – Control Panel, Drink Position

A drink that is dispensed from the touch panel and not from the P.O.S. will be indicated as a SPECIAL. This will be indicated by the * being illuminated in the display.

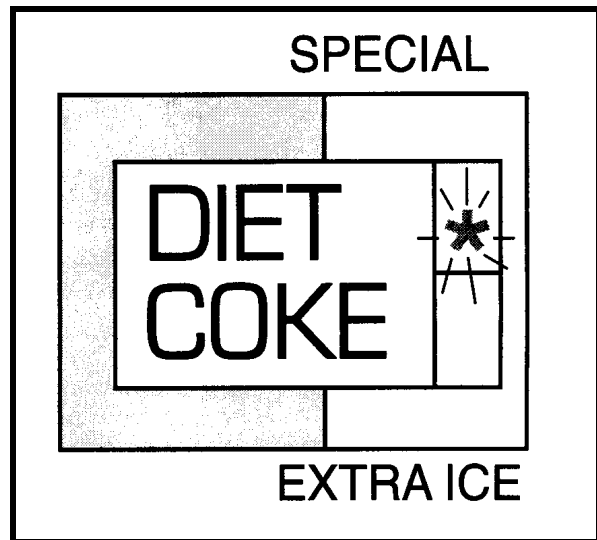

If the drink has the special ice requirements EXTRA ICE, the # will be illuminated in the display.

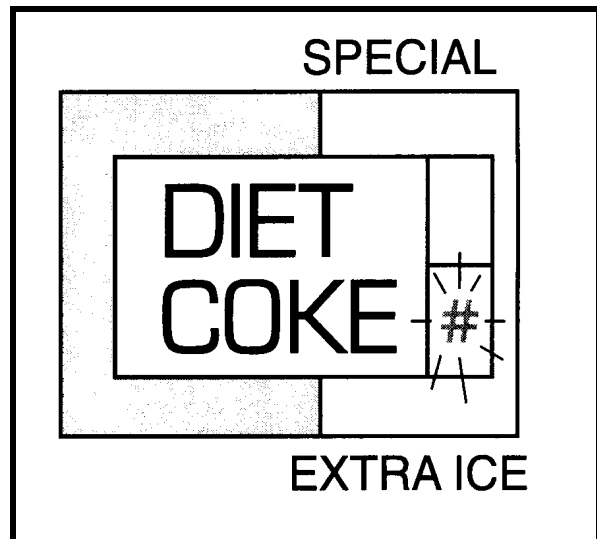

If the drink is a FLOAT drink, F will be illuminated in the display.

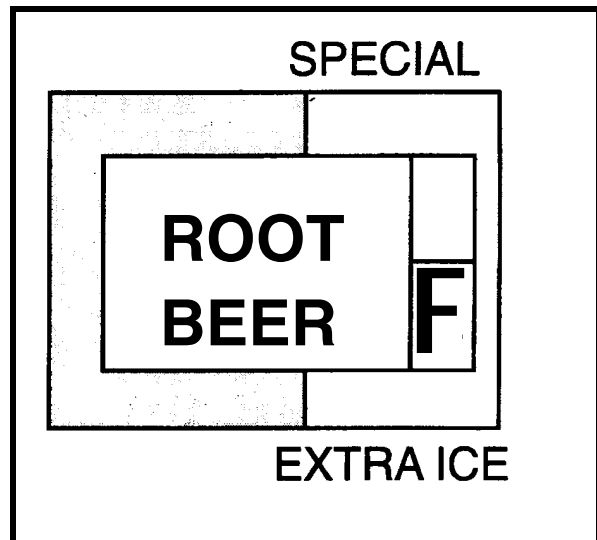

Automated Beverage System

A.B.S. Unit Major Subsystems Operation — Turret, Cup Extractor, & Conveyor

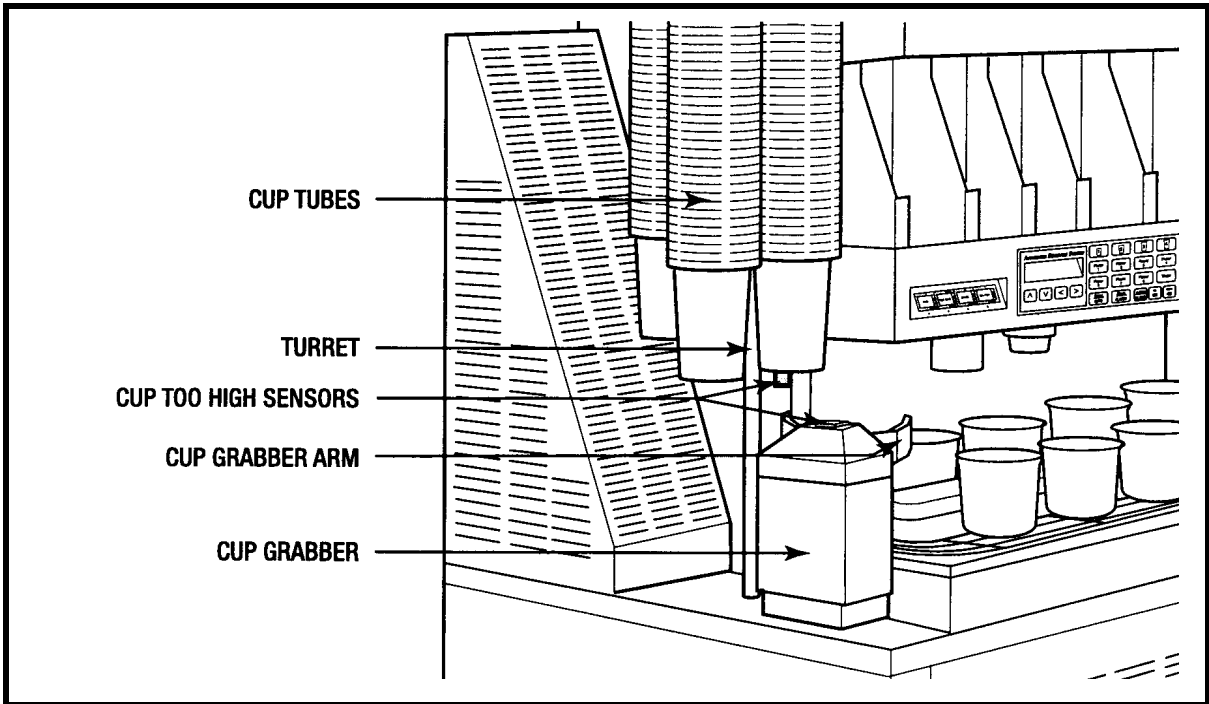

Cup Turret Components – Location Diagram

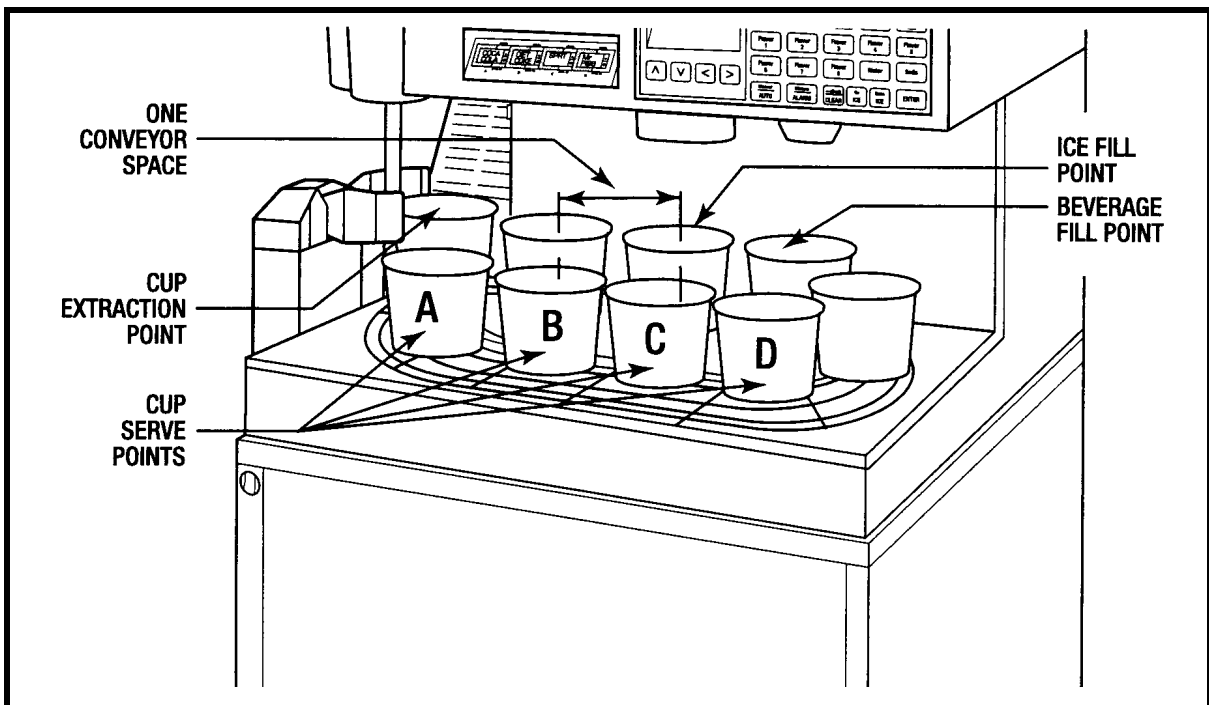

Cup Conveyor Components – Location Diagram

Automated Beverage System

A.B.S. unit Major Subsystems Operation — Turret

Cup Tubes Configuration

The cup tube configuration is 1 – Small; 1 – Child; 1 – Large; 1 – Medium; 1- XL.

The cup tube configuration for Australia is 1 – Small; 2 – Large; 2 – Medium.

The hole mounting pattern is such that the cup tubes will only mount in one location.

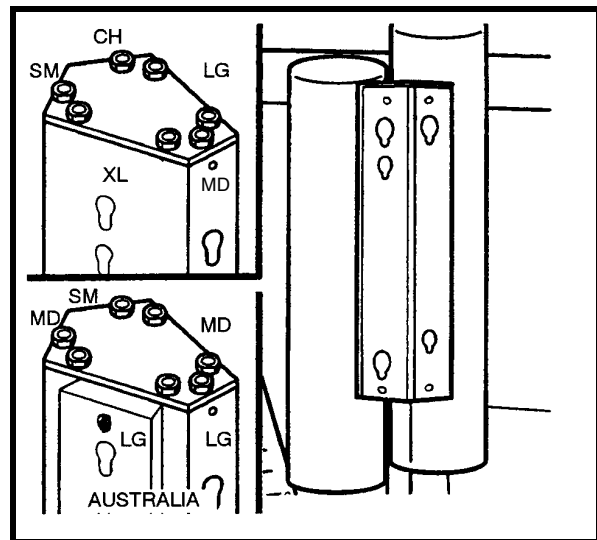

Rotating The Cup Turret

While in the manual mode – press the Cup Size button corresponding to the cup tube you wish to install. The turret will rotate until the correct turret face is forward, allowing easy mounting of the cup tube. In the standard configuration, the 5th cup size is not being used.

If there are two medium cup tubes, when button #3 is pressed once the first medium turret cup face is forward, the second time it is pressed the second medium turret face will rotate forward.

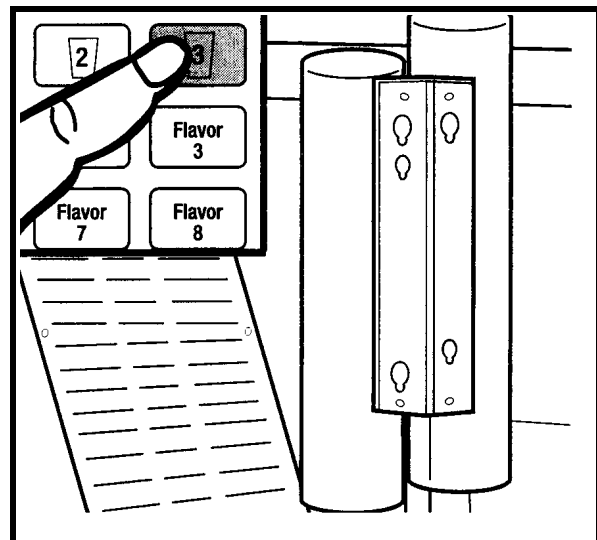

Other Cup Configuration

The unit can be configured with four or five cup sizes. If only four cup sizes are needed, usually two medium cup tubes are used.

The second medium cup tube can be omitted and an extra large cup substituted. The extra large cup tube mounting location can be identified by pressing cup size button #5.

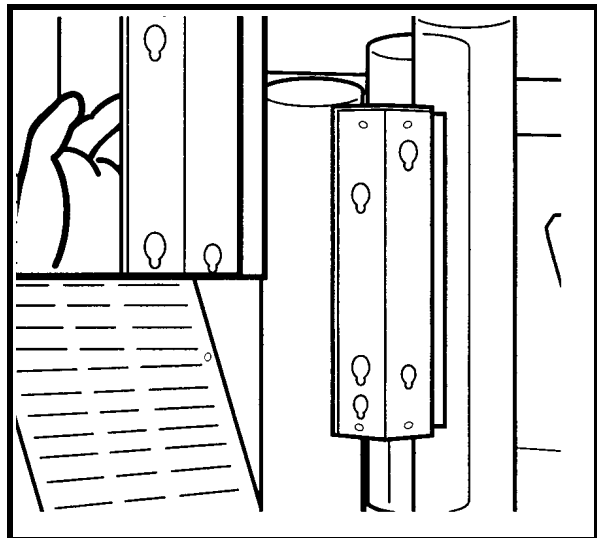

Automated Beverage System

A.B.S. unit Major Subsystems Operation — Cup Extractor

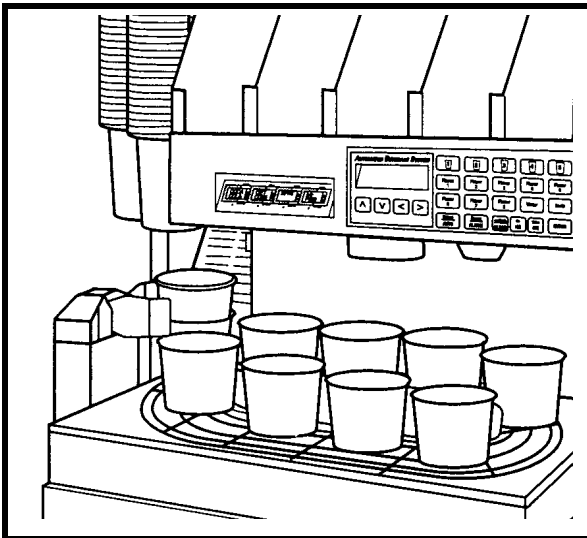

Cup Grabber Assembly

The cup grabber consists of two cup grabber arms actuated by a pneumatic cylinder, an elevating mechanism operated by a pneumatic cylinder, two guide rods, a Travel sensor and a Cup Empty sensor.

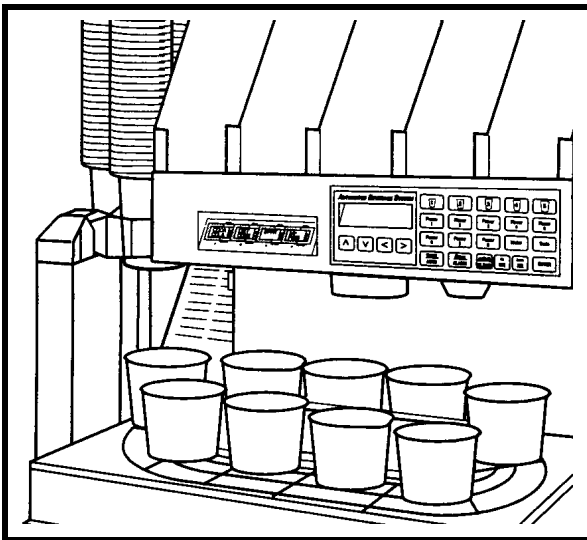

Cup Grabber Cycle

When the correct cup is aligned at the cup grabber, a pneumatic cylinder lifts the cup grabber to the cup. A sensor detects the full travel of the grabber during the lift motion. A signal is sent that the grabber is in position and then a pneumatic cylinder closes the grabber arms. If the arms close fully indicating “No Cup,” the control system will attempt to pull a cup from a second tube of same size cup if present. If no cup is available a “SOLD OUT” message will be displayed. If a cup is available the cup grabber will be lowered and the cup pulled from the cup tube.

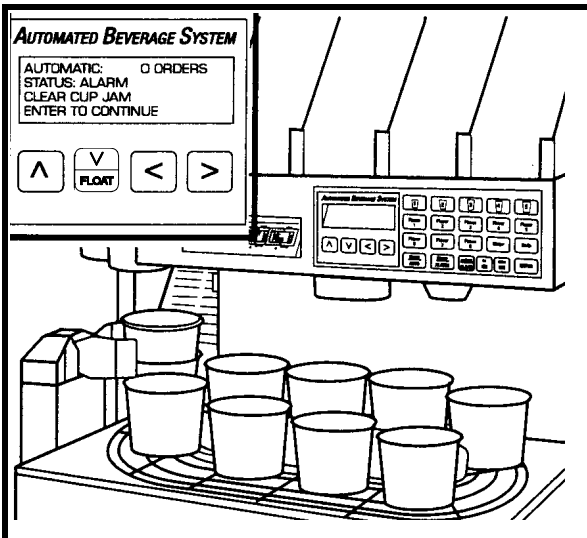

If the grabber arms close on a cup but during the lowering of the cup it falls incorrectly, a “CUP JAM” message will be displayed.

When the grabber successfully pulls a cup from the cup tube and is completely lowered, the grabber arms will open, dropping the cup into the conveyor. The conveyor will then advance and continue to make drinks.

Automated Beverage System

A.B.S. unit Major Subsystems Operation — Conveyor

Conveyor

The conveyor contains nine equally spaced cup holders. Each cup holder contains a ceramic magnet. A sensor located in the drip pan at the cup grabber detects the cup holders and thereby controls the movement of the conveyor and the position of the cup holders.

Note: The conveyor will not operate if there is a cup or any obstruction in the cup holder at Cup Serve

Point “A.”

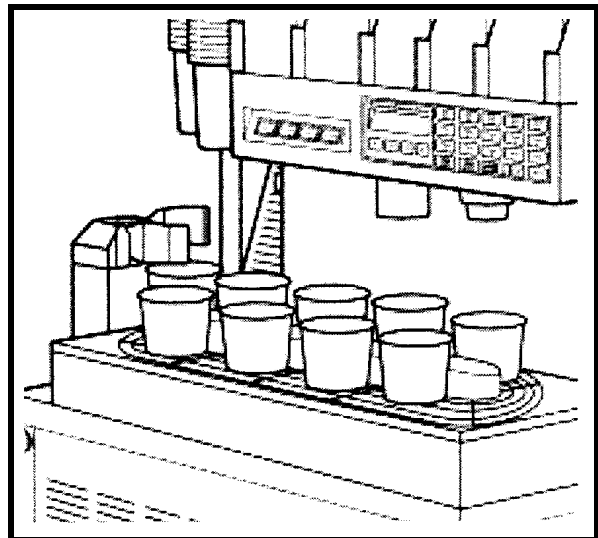

Cup Rest

The cup rest must be installed with the oval rails up and with the “Cup Positioning Bracket” must be at the rear of the drip tray. Check for the presence of a cup locator spring.

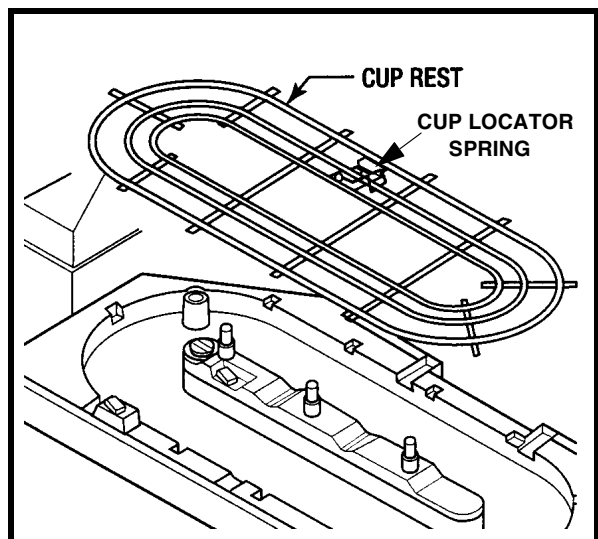

Water Deflector

Check to see water deflector is installed properly.

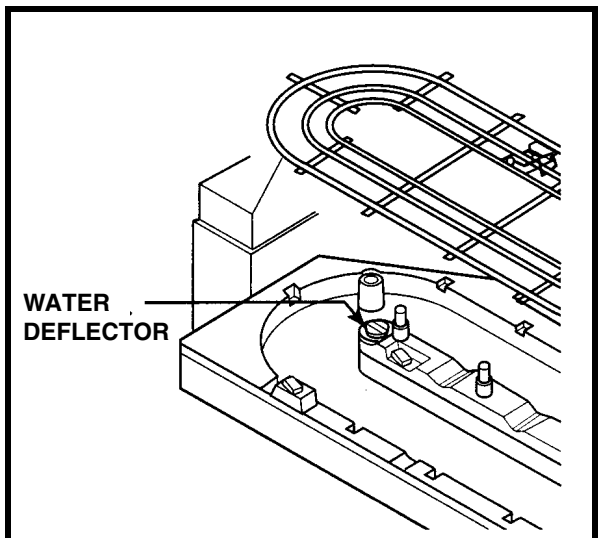

Automated Beverage System

A.B.S. unit Major Subsystems Operation — Conveyor

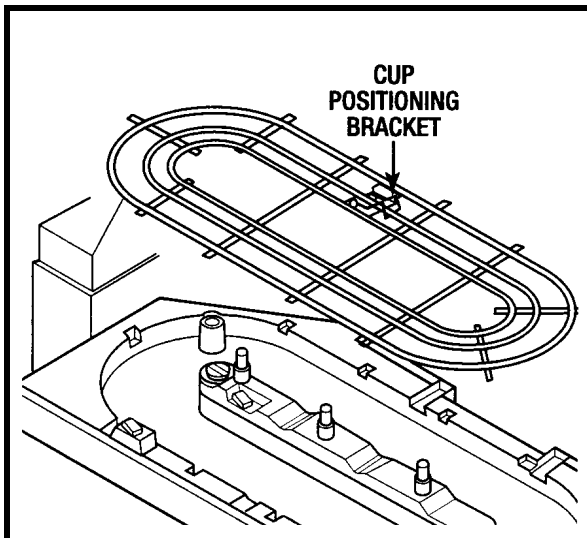

Cup Positioning Bracket

The cup positioning bracket, located on the cup rest, contains a spring that is positioned so it touches the cup in the cup holder as the cup moves past the spring. This moves the cup to the rear (based on the direction of movement) of the cup holder. This insures that all cups will be in the same position for dispensing regardless of its size.

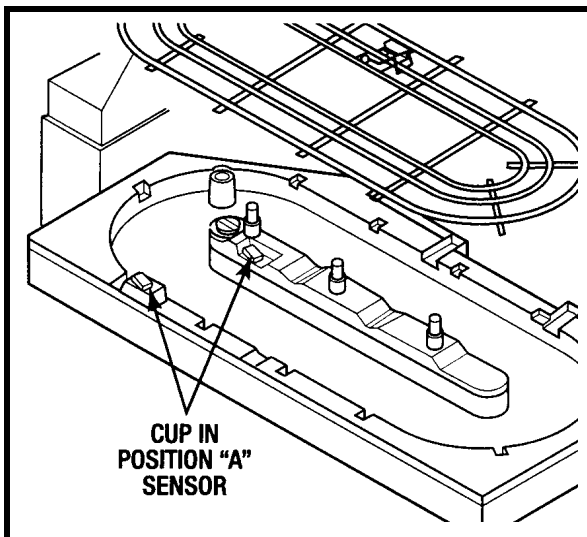

Cup In Position "A"

Part of the conveyor assembly is the cup in position "A" sensor. This senses if a cup is in the last conveyor position to prevent full cups from traveling into the grabber mechanism.

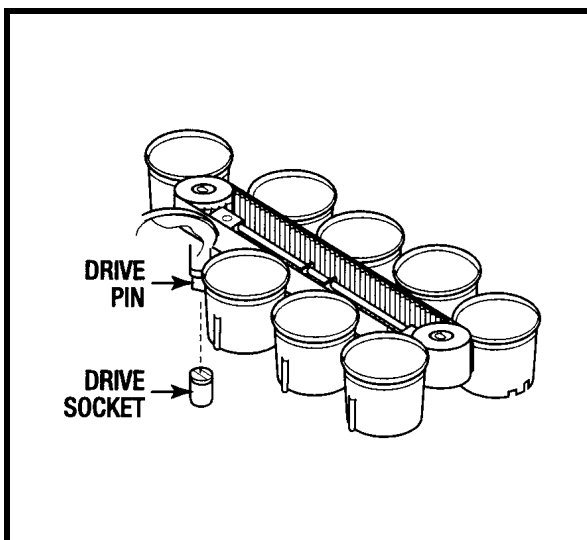

Reinstall Conveyor

Align the drive pin on the left side of the conveyor assembly so that the conveyor seats properly. The conveyor drive pin must engage the drive socket on the gear box. When installing the conveyor, it may be necessary to move the conveyor manually to allow the drive pin to insert into the drive socket.

Tighten the thumb screws on the cover.

Automated Beverage System

A.B.S. unit Major Subsystems Operation —

Ice Dispenser

Ice Gate Description

The ice gate is a pneumatically operated “gate” that is controlled by the Beverage Interface Board. The time the gate is open is very precise and determines the portion of ice dispensed. The gate opens and closes under pneumatic pressure. The gas is controlled by solenoids.

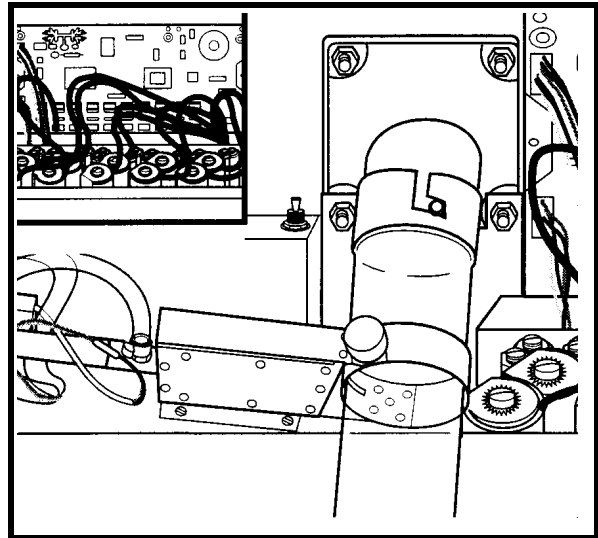

Ice Dispensing Cycle

The ice gate opens; the agitator turns to refill the ice chute and to maintain ice on the cold-plate; the ice gate closes; the agitator continues to fill the ice chute for the set period of time.

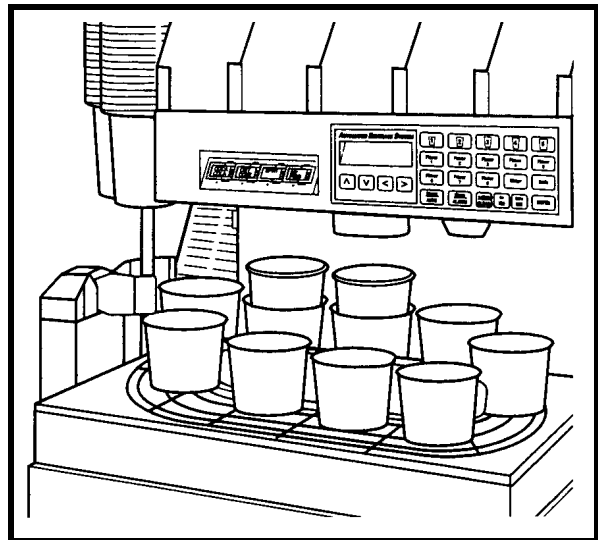

Low Ice – Refill Soon

The LOW ICE – REFILL SOON condition is sensed by the A.B.S. through a temperature sensor located in the ice bin.

The LOW ICE – REFILL SOON alarm sounds when the bin has about 40 drinks left in its capacity. It will resound with every tenth drink made, until refilled.

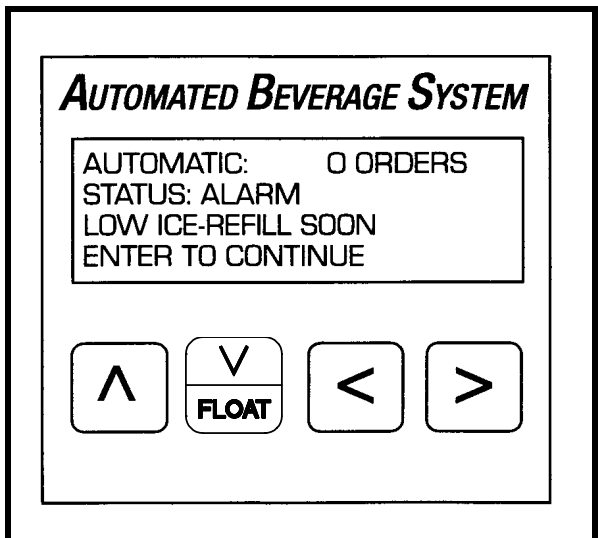

Automated Beverage System

A.B.S. unit Major Subsystems Operation — Ice Dispenser

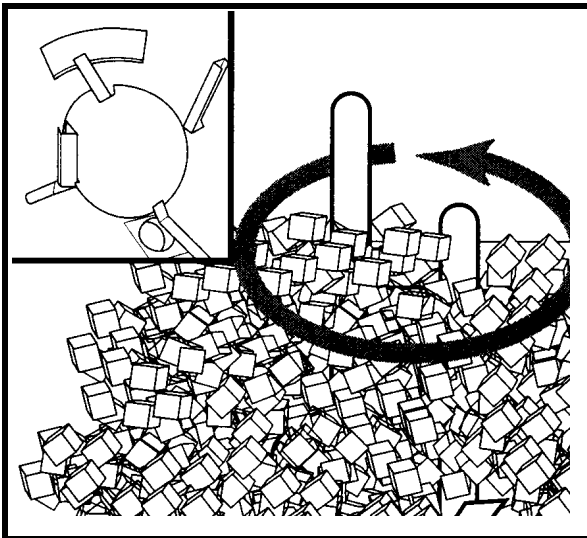

Auto-Agitate

Ice from the bin is used for the coldplate.

If the A.B.S. unit is idle for a period (programmed during setup), the agitator will agitate for a preset period to maintain ice on the coldplate.

The ice bin has a sensor that detects a low ice condition and displays a warning.

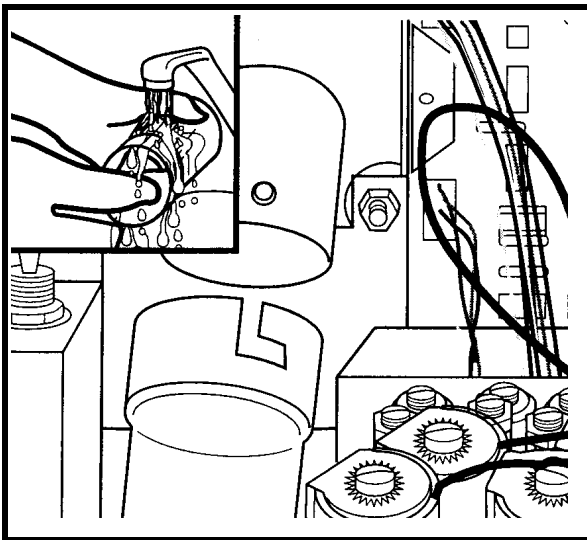

Ice Chute

The ice chute directs the ice into the cup. It can be removed for cleaning or replacement. Access to the ice chute is obtained by removing the cup lid rack.

Automated Beverage System

A.B.S. Unit Major Subsystems Operation — Ice Dispenser

Ice Chute Removal & Replacement

1. With the unit in manual mode, remove the cup lid rack, and conveyor.

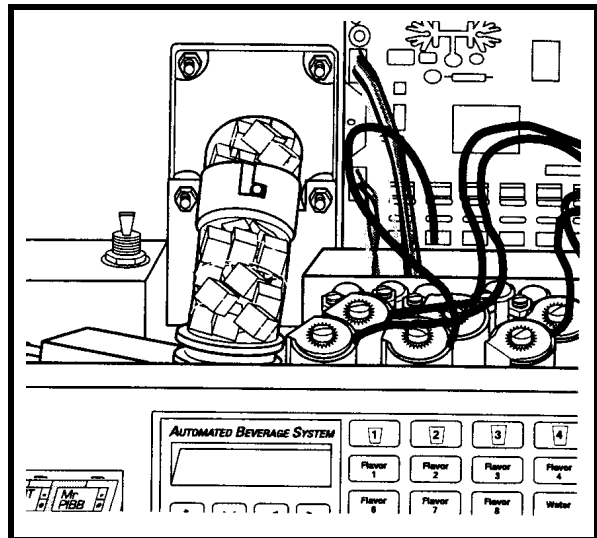

2. **WARNING:** Shut off the manual ice gate switch.

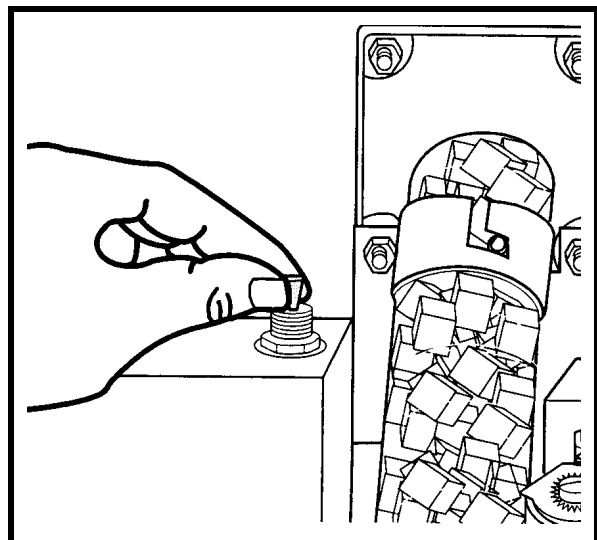

3. Slide the gate out of the chute.

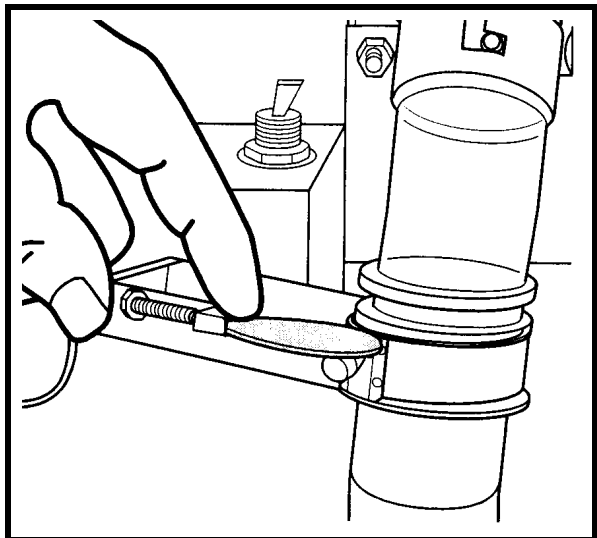

Automated Beverage System

A.B.S. Unit Major Subsystems Operation — Ice Dispenser

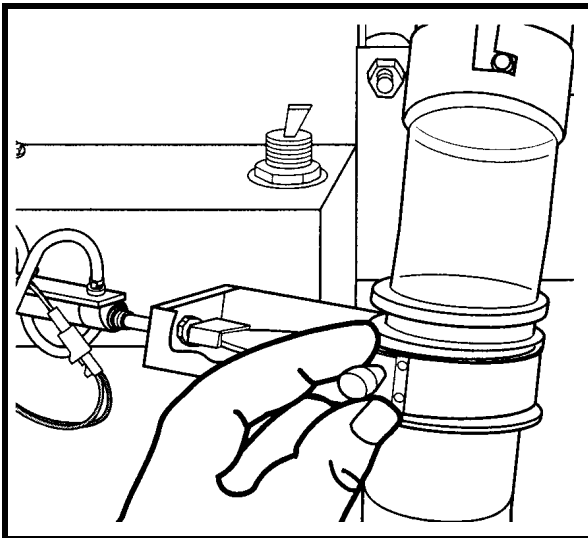

4. Pull the ice chute release mechanism out and turn the chute clockwise 1”.

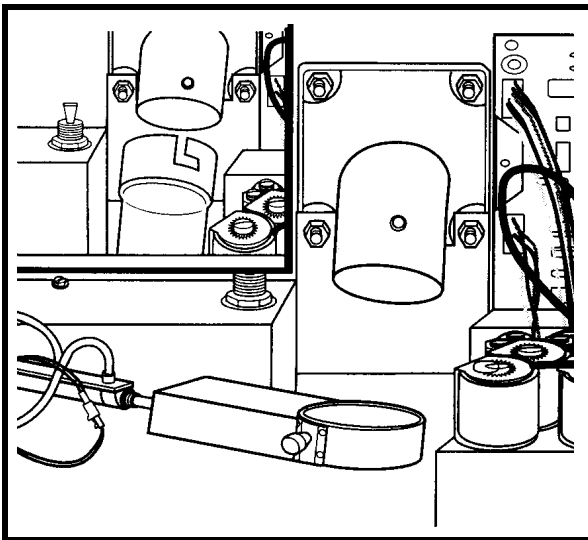

5. Holding the ice chute release mechanism, rotate the ice chute clockwise and pull down. Drop the ice chute down through the ice gate frame and replace it. To reinstall ice chute, follow procedures in reverse order.

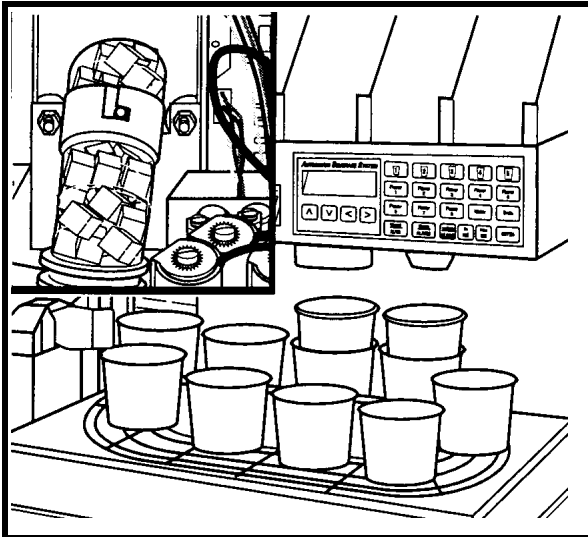

6. Return the A.B.S. unit to normal operation.

Automated Beverage System

A.B.S. Unit Major Subsystems Operation — Beverage Dispenser

Valve Description

The dispensing valve is located behind the touch panel and is made up of five blocks, each containing two solenoids, two flow controls, and two shutoffs. The blocks are permanently manifolded together to supply a single outlet nozzle. (The top view is depicted.)

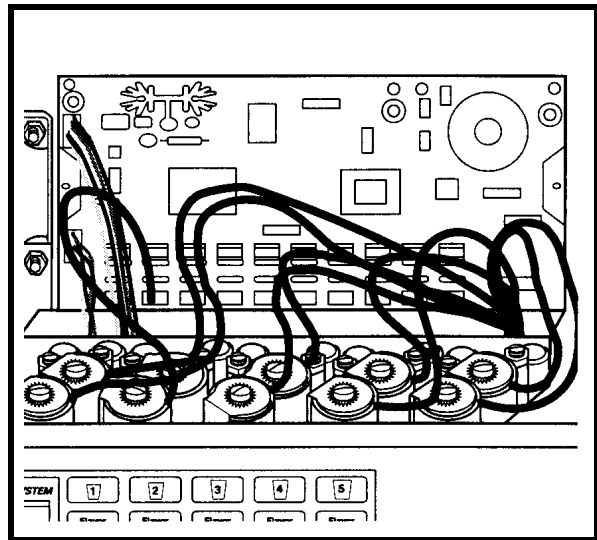

Beverage Dispensing

The valve opens to dispense the desired syrup and water in the desired portions into the cup.

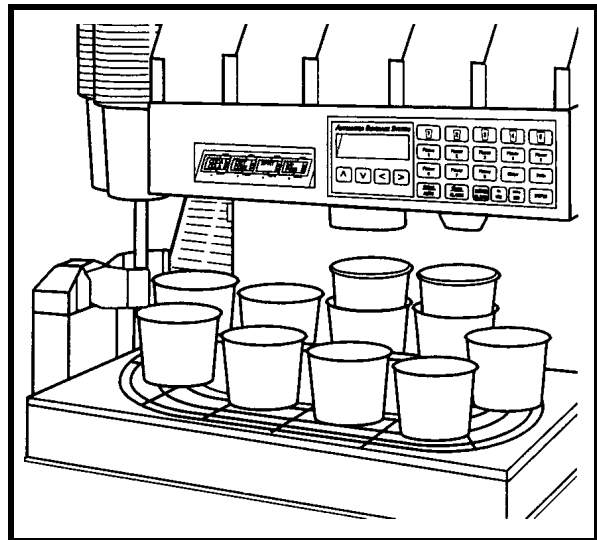

If foaming is an issue, the service agent can program a top-off. The initial portion will be dispensed. After a delay, the balance of the drink will be dispensed.

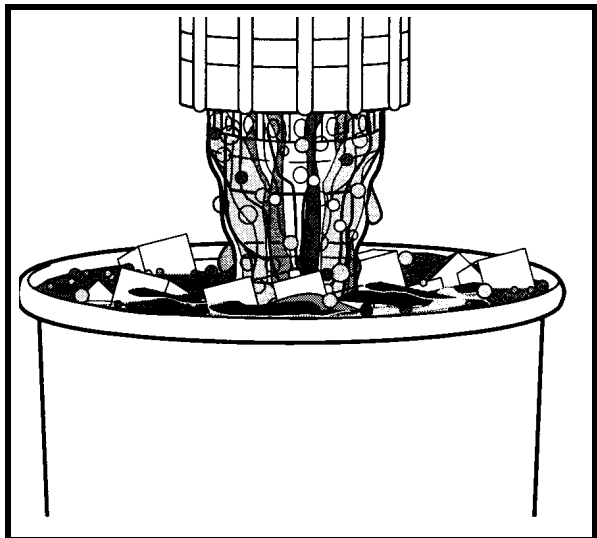

Automated Beverage System

A.B.S. Unit Major Subsystems Operation — Pre-Chiller

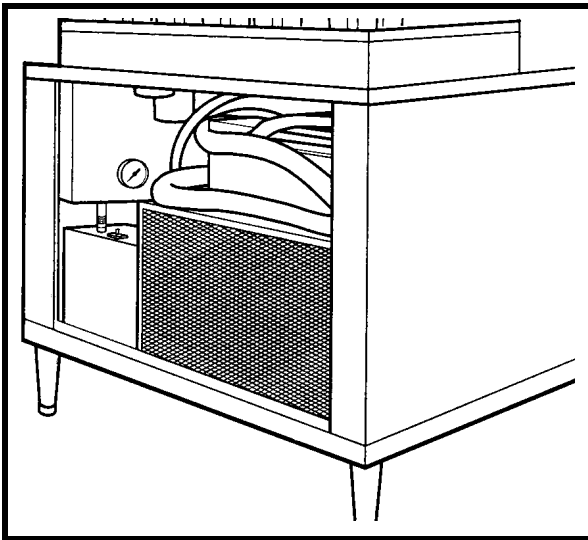

Optional Pre-Chiller

An optional pre-chiller must be installed if carbonated water and plain water are not chilled in a backroom package.

Automated Beverage System

Daily Start-Up Procedures —

Fill Ice Bin

Fill Ice Bin

Remove the ice bin lid and fill with ice cubes to the top of the bin. Do not overfill. The bin cover must be able to rest securely on the top of the bin.

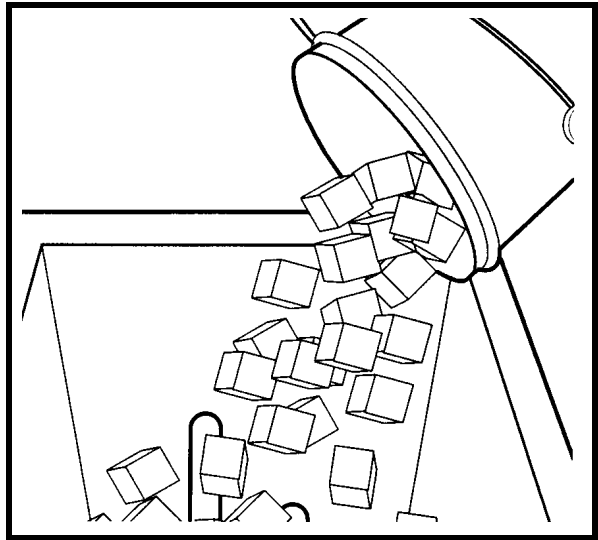

Automated Beverage System

Daily Start-Up Procedures — Filling Cup Tubes

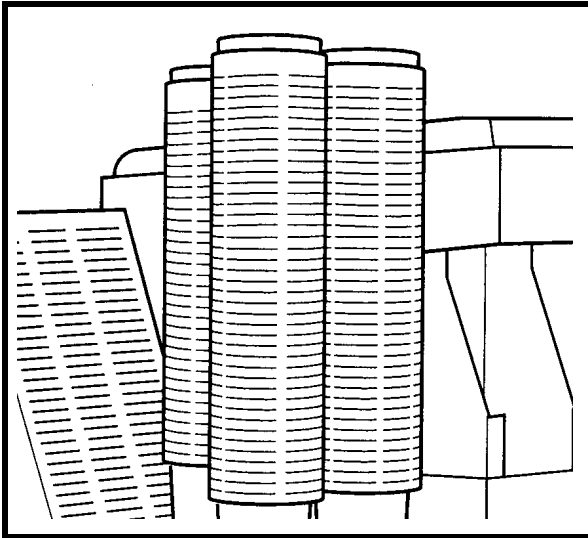

Rotating The Cup Turret

Place the unit in the manual mode – press the Cup Size button corresponding to the cup tube you wish to fill. The turret will rotate until the correct turret face is forward, allowing easy filling of the cup tube.

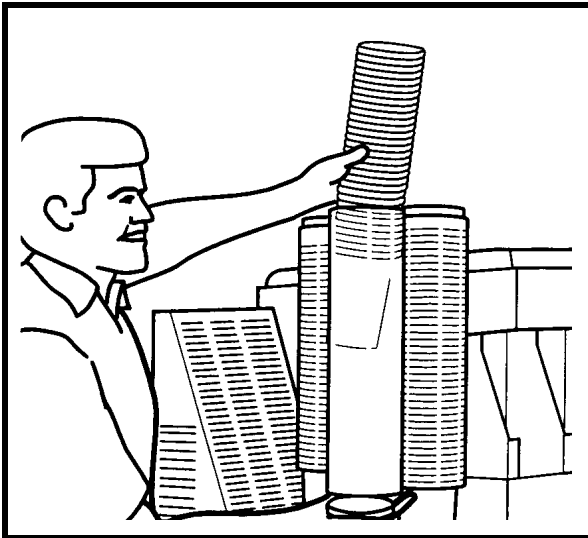

Filling Cup Tubes

Remove top cup tube cover and hold under the cup tube to catch cups and prevent them from falling through.

Return top cup tube cover.

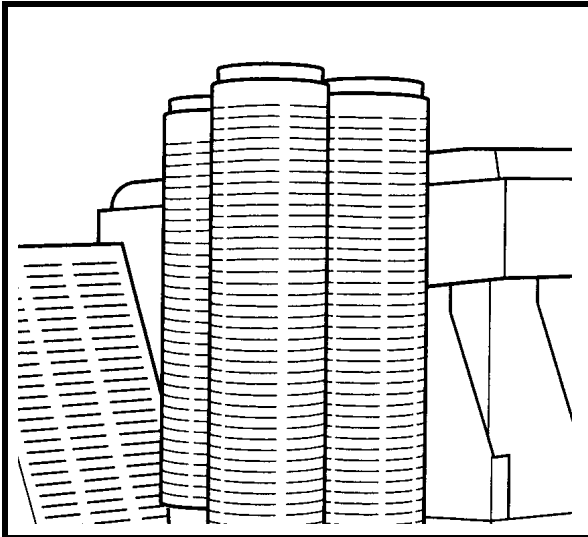

Do not over fill the cup tubes. Damage may result to the cup tubes or may result in cup jams.

When all tubes have been filled, return to automatic mode by pressing the Manual/Auto button.

Automated Beverage System

Closing/Sanitation Procedures

Daily Cleaning/Sanitizing Tasks

At close, the following tasks should be performed:

- Put in manual mode (do not shut off main power).
- Remove and clean the conveyor, and cup rest.
- Clean drip tray and exterior surfaces.
- Pour warm (NOT HOT) water down the drip tray drain.
- Check for water deflector. If missing, use the spare located behind the lid holder panel.
- Reinstall cup rest and conveyor.
- Remove and clean the valve nozzle and diffuser.
- Wipe down and clean the A.B.S. unit with sanitizing solution.

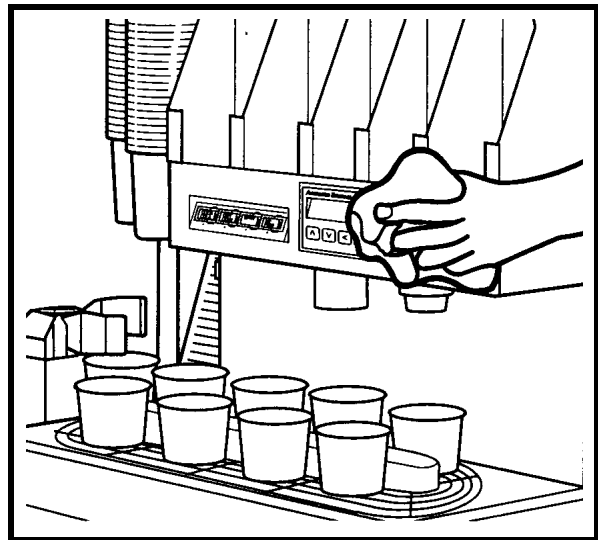

Remove Conveyor & Cup Rest

Remove the conveyor by removing the 3 thumb screws holding it in place. Remove the cup rest by lifting it up and removing it. Wash the conveyor, conveyor cover, and the cup rest in warm soapy water then rinse with clean potable water.

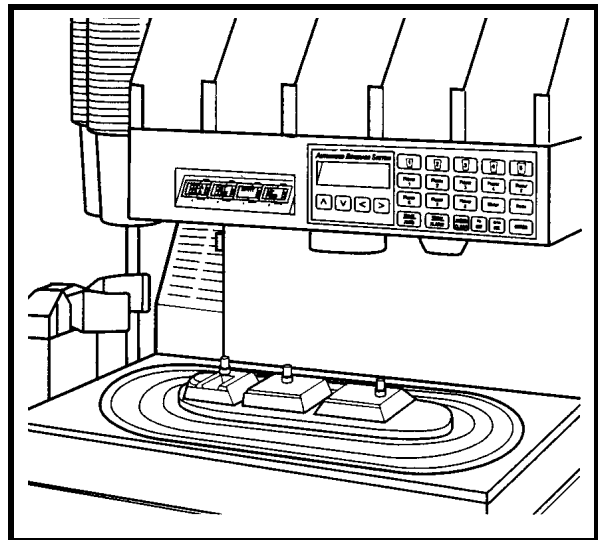

Automated Beverage System

Closing/Sanitation Procedures

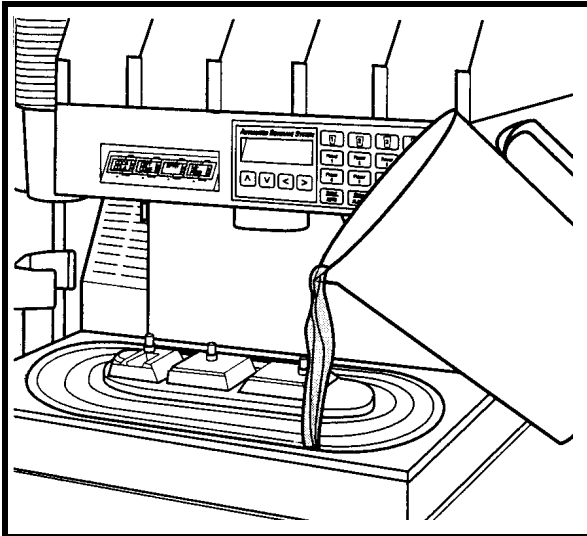

Clean Drip Tray & Exterior Surfaces

Clean drip tray and all exterior surfaces with warm soapy solution and rinse with clean potable water.

Pour warm (NOT HOT) water down the drip tray drain to flush drain line.

Inspect water deflector after cleaning to check for proper installation.

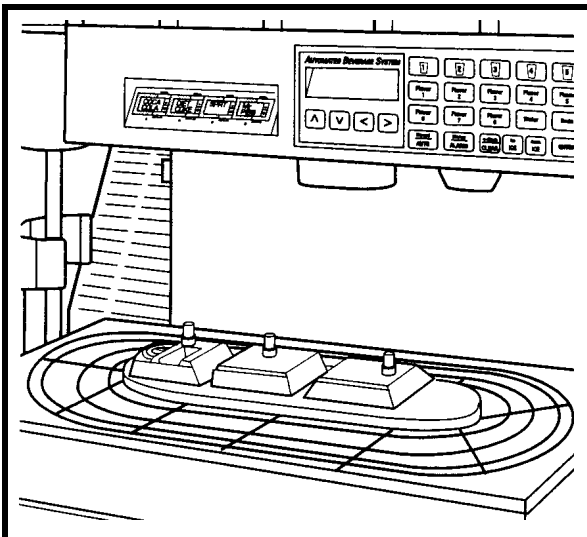

Reinstall Cup Rest

The cup rest must be installed with the oval rails up and the “Cup Positioning Bracket” must be at the rear of the drip tray.

The cup positioning bracket, located on the cup rest, contains a spring that is positioned so it touches the cup in the cup holder as the cup moves past the spring. This moves the cup to the rear (based on the direction of movement) of the cup holder. This insures that all cups will be in the same position regardless of its size.

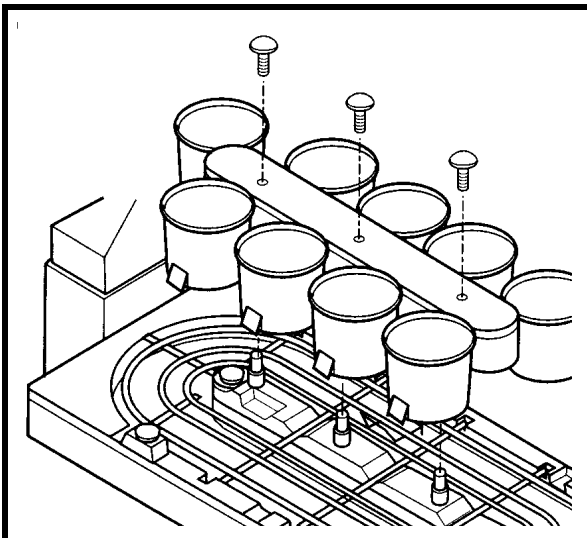

Reinstall Conveyor

Align the drive pin on the left side of the conveyor assembly so that the conveyor seats properly. The conveyor drive pin must engage the drive socket on the gear box. When installing the conveyor, it may be necessary to move the conveyor manually to allow the drive pin to insert into the drive socket.

Tighten the thumb screws on the cover.

Automated Beverage System

Closing/Sanitation Procedures

Clean Nozzle & Diffuser

- Remove the nozzle by twisting clockwise. Then pull the diffuser straight down. Separate the diffuser. Clean the beverage nozzle and diffuser using nozzle brush and rinse with carbonated water.
- Reinstall diffuser nozzle

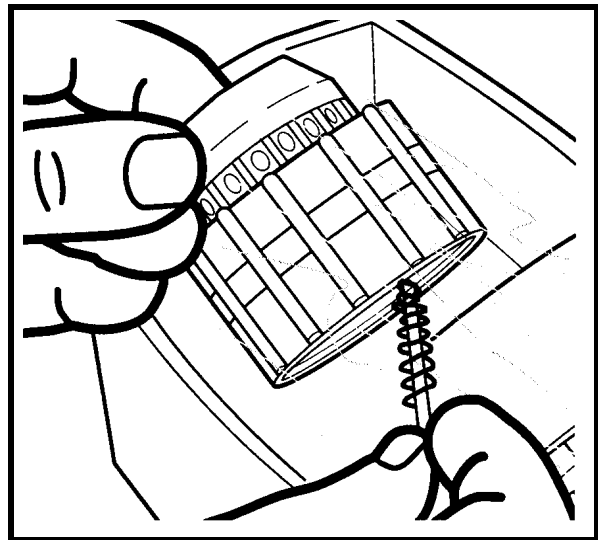

Wipe Down A.B.S. Unit

At the end of closing shift, the crew should wipe down the exterior of the unit with a sanitizing solution.

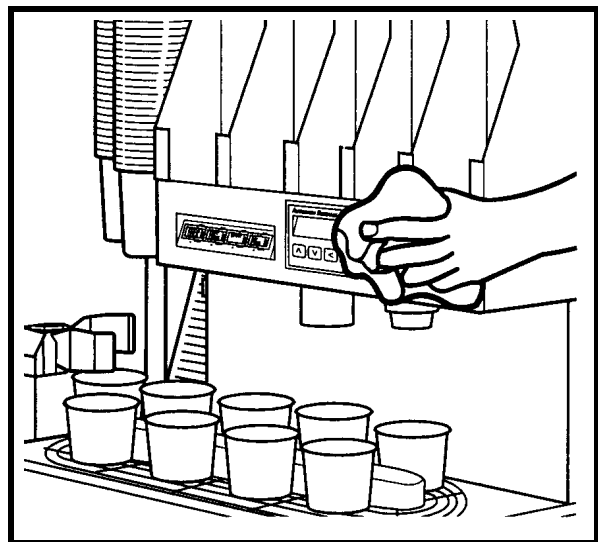

Automated Beverage System

Daily Cleaning/Sanitation Procedures

Daily Cleaning Conveyor Thru-Beam (Last Position) Sensor

The thru-beam (Position “A”) sensor requires cleaning. If not clean, the sensor may work intermittently.

With the conveyor off, wet a clean napkin with carb water and carefully wipe the lens of the thru-beam sensor emitter and the receiver.

(Note: Don't use cleaning towel on sensor, it may leave film on sensor lens.)

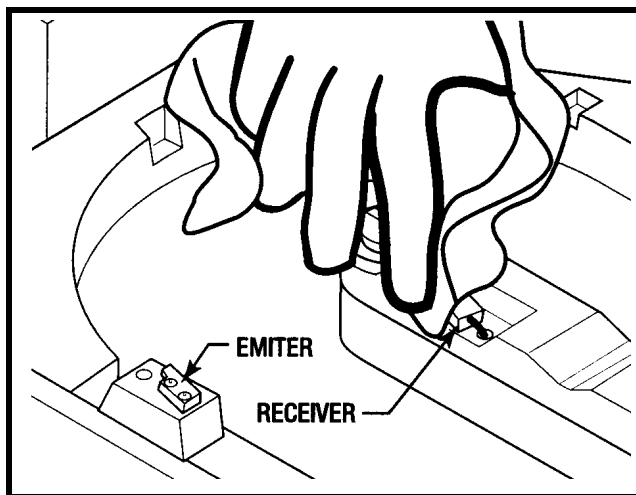

Automated Beverage System

Monthly Cleaning/Sanitation Procedures

Monthly Cleaning/Sanitation of Ice Bin

WARNING: DO NOT USE SHARP OBJECTS, METAL DEVICES OR ABRASIVES ON THE ICE HOPPER, TOP COVER, ICE CHUTE OR AGITATOR DISC AS IRREPARABLE DAMAGE MAY RESULT. DO NOT USE SOLVENT OR OTHER CLEANING AGENTS AS THEY MAY ATTACK THE PLASTIC MATERIAL.

Soapy Solution: Use a mixture of mild detergent and warm (100°F) potable water.

Sanitizing Solution: Use 1/2 ounce of non-scented household bleach in one gallon of potable water. Preparing the sanitizing solution at this ratio will create a solution of 200 PPM chlorine.

1. Turn ABS unit power switch **OFF**. The switch is located on the lower left-hand side of the ABS unit front panel.
2. Remove top cover and set aside.
3. Remove all ice from the hopper and discard. If necessary, pour clean, potable water slowly into the hopper to assist in melting the ice.
4. After all the ice is removed inspect the cold plate areas and drains as follows:
 - A. Remove the splash panel and the plastic cold plate access cover.
 - B. Locate and remove any debris from the drain trough and cold plate. Make sure the drain holes are not clogged.
 - C. Reinstall the cold plate access cover and splash panel.
5. Remove the agitator retainer and the ice agitator assembly.
6. Using a long handled nylon bristle brush, clean the interior of the hopper, top cover, agitator, agitator cover and cold plate with warm, soapy solution. The cold plate is to be cleaned by reaching through the ice opening into the hopper bottom with the long handle brush. Be certain to clean the entire surface area of the cold plate including all the corners. Thoroughly rinse the hopper, top cover, agitator, agitator cover and the cold plate with clean potable water. Automated Beverage System
7. Using a long handle nylon bristle brush, clean the interior of the ice chute with the warm, soapy solution. Access to the ice chute can be gained via the interior of the hopper and the ice chute outlet on the front of the ABS unit. Thoroughly rinse the ice chute with clean, potable water.
8. Reinstall the agitator assembly.
9. Using a mechanical spray bottle filled with sanitizing solution, spray the entire interior of the ice bin, ice chute and ice agitator assembly. Allow to air dry.
10. Turn the ABS unit power switch **ON**.
11. Return the ABS unit to **AUTO** mode.

Automated Beverage System

Quarterly Cleaning/Sanitation Procedures

QUARTERLY SANITATION OF POST-MIX SYRUP SYSTEM

IMPORTANT: Only qualified Service Personnel should perform the sanitizing procedure on the post-mix syrup systems.

The post-mix syrup systems should be sanitized every 90 days using a non-scented household liquid bleach containing a 5.25% sodium hypochlorite concentration. Proceed as follows to sanitize the post-mix syrup systems.

1. Disconnect syrup supplies from the syrup systems.
2. Rinse the quick disconnects (syrup tank systems) or bag-in-box connectors (syrup bag-in-box systems) in warm, potable water.

STEP 1: WASH THE SYRUP SYSTEMS



WARNING: To avoid possible personal injury or property damage, do not attempt to remove the syrup tank cover until CO₂ pressure has been released from the

3. Using a clean syrup tank (syrup tank system) or a five gallon container (bag-in-box system), prepare a full tank or container of liquid dishwasher detergent by using 70° F (21° C) to 100° F (38° C) potable water and 5 oz.(15 ml) of liquid dishwasher detergent to one gallon of potable water. Stir detergent solution to thoroughly mix the solution.
4. Syrup Tank Systems.
 - A. Observe and note CO₂ pressure setting on the syrup tank's CO₂ regulator, then re-adjust the CO₂ regulator to 60 to 80 PSI. Pressurize the syrup tank, that contains the detergent solution to 60 to 80 PSI.
 - B. Connect the pressurized (60 to 80 PSI) detergent solution tank into one of the syrup systems.
5. Bag-In- Box Syrup Systems.
 - A. Install the bag valves, cut from empty bag-in-box syrup containers, on the end of syrup container's syrup outlet tube connectors.
 - B. Place syrup outlet tube, with bag valve on end, into container of detergent solution.

Automated Beverage System

Quarterly Cleaning/Sanitation Procedures

QUARTERLY CLEANING/SANITATION PROCEDURES

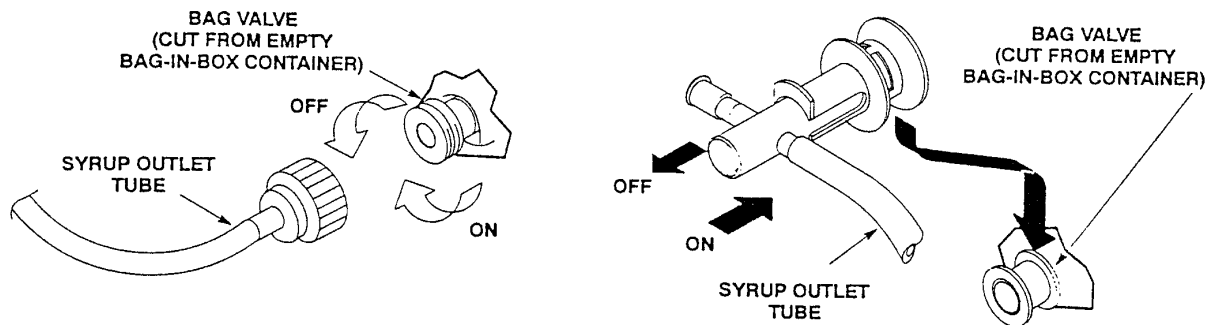

6. Flush the syrup system and dispensing valve as follows:
 - A. Place a waste container under the dispensing valve.
 - B. Place the ABS unit in the **TEST/VALVE TEST** mode and press each flavor button until all the syrup is expelled and water fills the tubing.
 - C. Continue to activate each dispensing valve in cycles (**ON** for 15 seconds, **OFF**, then **ON** for 15 seconds). Repeat **ON** and **OFF** cycles for 15 cycles.
7. Connect the detergent solution to any remaining syrup systems and flush syrup out of the syrup systems as instructed in **Step 6** above.
8. Remove the detergent solution source from the syrup system.

STEP 2: FLUSH THE SYRUP SYSTEMS

9. Syrup Tank Systems.
 - A. Connect a syrup tank filled with potable water pressurized at 60 to 80 PSI, into one of the syrup systems.
10. Bag-In-Box Syrup System.
 - A. Fill a five gallon container with potable water.
 - B. Place syrup outlet tube, with bag valve on end, into container of potable water.
11. Flush the detergent solution out of the syrup system and dispensing valve as follows:
 - A. Place a waste container under the dispensing valve.
 - B. Place the ABS unit in the **TEST/VALVE TEST** mode and press each flavor button until all the detergent solution is expelled and water fills the tubing. Activate the dispensing valve for one minute to purge all detergent solution and flush out the syrup system.
 - C. Continue to activate each dispensing valve in cycles (**ON** for 15 seconds, **OFF**, then **ON** for 15 seconds). Repeat **ON** and **OFF** cycles for 15 cycles.

Automated Beverage System

Quarterly Cleaning/Sanitation Procedures

12. Connect the potable water source to any remaining syrup systems and flush the detergent solution out of the syrup systems as instructed in **Step 11** above. Automated Beverage System
13. Remove the potable water source from the syrup system.

STEP 3: SANITIZE THE SYRUP SYSTEMS

14. Using a clean syrup tank (syrup tank system) or a five gallon container (bag-in-box system), prepare sanitizing solution using 70° F (21° C) to 100° F (38° C) potable water and 5 oz. (15 ml) of non-scented household liquid bleach that contains a 5.25% sodium hypochlorite concentration to one gallon of potable water. This mixture *must not* exceed 200 PPM of chlorine. Stir the sanitizing solution to thoroughly mix.
15. Syrup Tank Systems.
 - A. Connect the pressurized (60 to 80 PSI) sanitized solution tank into one of the syrup systems
16. Bag-In-Box Syrup System.
 - A. Place all syrup outlet tubes, with bag valves on, into the container of sanitizing solution.
17. Sanitize the syrup system and dispensing valve as follows:
 - A. Place a waste container under the dispensing valve.
 - B. Place the ABS unit in the **TEST/VALVE TEST** mode and press each flavor button until all the water is expelled and sanitizer fills the tubing. Activate the dispensing valve for one minute to purge all water out of and install sanitizing solution into the syrup system and dispensing valve.
 - C. Continue to activate each dispensing valve in cycles (**ON** for 15 seconds, **OFF**, then **ON** for 15 seconds). Repeat **ON** and **OFF** cycles for 15 cycles.
18. Repeat **Steps 15, 16 and 17** to flush water out of and install sanitizing solution in the remaining syrup systems and dispensing valve.
19. Remove sanitizing solution source from the system.
20. Allow the sanitizing solution to remain in the syrup systems for not less than **TEN MINUTES** and no more than **FIFTEEN MINUTES (MAX)** contact time.

STEP 4: WATER FLUSH THE SYRUP SYSTEMS



WARNING: Flush sanitizing solution from the syrup systems as instructed. Residual sanitizing solution left in the syrup systems could create a health hazard.

21. Fill the syrup tank (syrup tank system) or a five gallon container (bag-in-box system) with potable water.

Automated Beverage System

Quarterly Cleaning/Sanitation Procedures

22. Syrup Tank Systems.

- A. Connect a syrup tank filled with potable water and pressurized at 60 to 80 PSI, into one of the syrup systems.

23. Bag-In-Box Syrup System.

- A. Place all syrup outlet tubes, with bag valves on, into a container of potable water.

24. Flush the sanitizing solution from the syrup system and the dispensing valve as follows:

- A. Place a waste container under dispensing valve.
- B. Place the ABS unit in the **TEST/VALVE TEST** mode and press each flavor button until all the sanitizer is expelled and water fills the tubing. Activate the dispensing valve for one minute to purge all the sanitizing solution out of the syrup system and the dispensing valve.
- C. Continue to activate each dispensing valve in cycles (**ON** for 15 seconds, **OFF**, then **ON** for 15 seconds). Repeat **ON** and **OFF** cycles for 15 cycles.

25. Repeat **Steps 22, 23 and 24** to flush sanitizing solution out of the remaining syrup systems and dispensing valve.

26. Remove the potable water source from the syrup system.

STEP 5: PURGE THE WATER OUT OF THE SYRUP SYSTEMS TO RESTORE UNIT OPERATION

27. Syrup Tank Systems.

- A. Noting syrup tanks CO₂ regulator pressure setting observed in **Step 4** preceding, re-adjust CO₂ regulator to the observed pressure setting.
- B. Connect the tanks containing the syrup into the syrup systems.

28. Bag-In-Box Syrup System.

- A. Remove all bag valves from syrup outlet tubes.
- B. Connect bag-in-box syrup containers into the syrup systems.

29. Place a waste container under the dispensing valve. dispense from all dispensing valve to permit the syrup to purge all the potable water from the syrup systems and the dispensing valves. Continue to dispense from the dispensing valves until only the syrup is dispensed from the syrup systems and valve.

30. Dispose of waste sanitizing solution in a sanitary sewer, not in a storm drain, then thoroughly rinse the inside and outside of the container that was used for sanitizing solution to remove all sanitizing solution residue.

Automated Beverage System

Troubleshooting

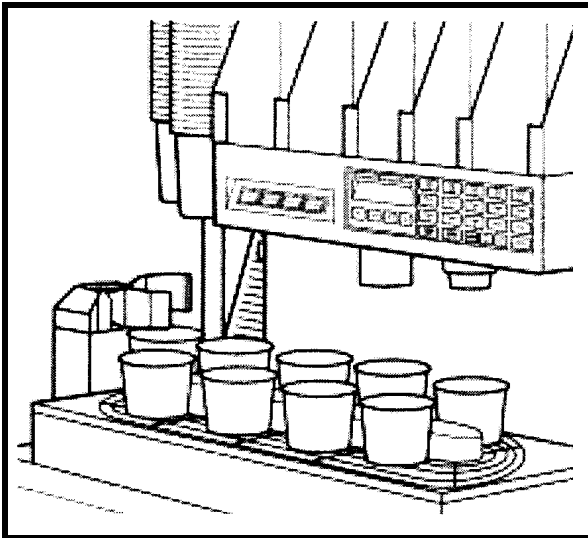

Important: Only qualified personnel should service internal components or electrical wiring of the A.B.S. unit.



A.B.S. unit Service

The A.B.S. Unit is serviced by an authorized Coca-Cola Service Agent.

Call 1-800-241-COKE.

Automated Beverage System

Troubleshooting

If the A.B.S. unit fails to operate properly, check to see that there is power to the unit.

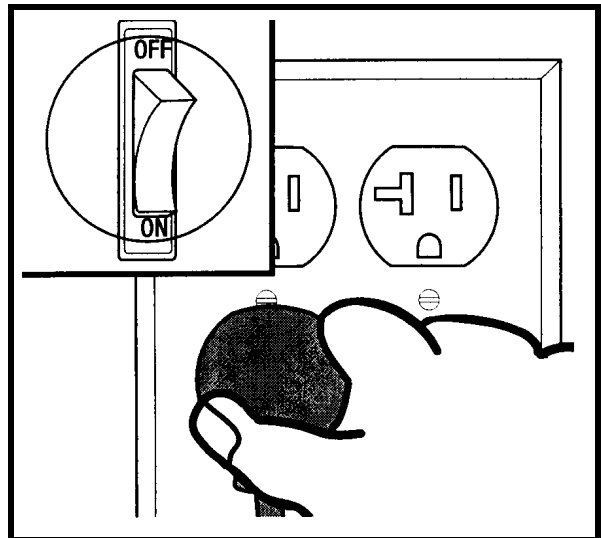

Check the ice bin for ice.

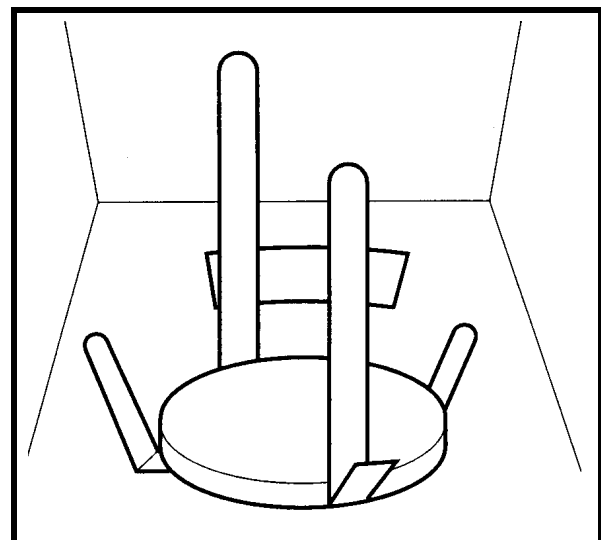

If the A.B.S. unit does not dispense, check the Troubleshooting chart on pages 54 - 56.

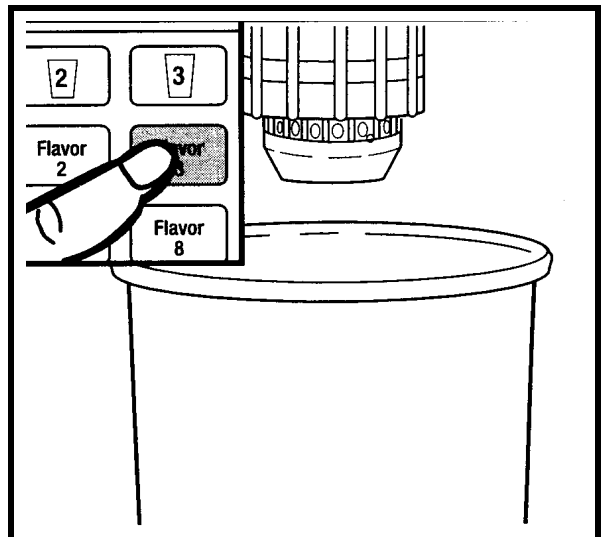

Automated Beverage System

Handling Alarms & Errors — Alarm & Warning Messages

Alarm & Warning Messages

When an alarm occurs, press the Silence/Alarm button to silence the alarm. Read the display to determine the problem so that the appropriate corrective action can be taken.

LEFT and RIGHT arrow are used to scroll the alarm list and the number of unresolved warnings and alarms are displayed with direction cues to scroll.

Listed below are all of the Alarm and Warning messages that may appear on the display screen.

Message	Explanation	Corrective Action
(X) CUP OUT AT STATION (Y)	The cup tube for size (X) is empty at station (Y).	Refill the empty cup tube with the correct cup size and then press ENTER to continue dispensing.
CLEAR SYRUP SOLD OUT	The clear syrup (Sprite) is sold out (empty B.I.B.). Sensor must be installed and connected to the A.B.S. system for this warning to occur.	Connect a new syrup supply and the A.B.S. unit will continue. If the ENTER button is pressed before the syrup supply is replenished, automatic operation will resume but only the cup and ice will be dispensed for this flavor.
LOW ICE – REFILL SOON	Ice level in the ice bin is too low.	Refill the ice bin with ice. Press ENTER.
CLEAR CUP JAM	Cup(s) jammed in the conveyor at the cup extraction position and the conveyor and turret are unable to operate.	Remove all cups from the conveyor cup holders at the Extract Position before pressing the ENTER button. Another cup will be extracted and dispensing will continue.
NO CUP EXTRACTED	The gripper did not or could not extract a cup from the cup tube.	Check cup supply at the extract station and make sure the cups are not stuck. Make sure the gripper pads are not damaged.
TURRET STALLED	Cup(s) jammed in the conveyor at the cup extraction position and the conveyor and turret are unable to operate.	Remove all cups from the conveyor cup holders at the Extract Position before pressing the ENTER button. Another cup will be extracted and dispensing will continue.
CONVEYOR STALLED	Cup(s) jammed in the conveyor at the cup extraction position and the conveyor and turret are unable to operate	Remove all cups from the conveyor cup holders at the Extract Position before pressing the ENTER button. Another cup will be extracted and dispensing will continue.
AIR OR CO ₂ LOW OR OUT	CO ₂ supply is low or empty or air compressor not operating.	Change CO ₂ cylinder or have bulk tank refilled. Check cause not operating and repair.

Automated Beverage System

Troubleshooting – Trouble/Probable Cause Chart

Problem	Probable Cause	Corrective Action
Blown fuse or circuit breaker	A. Short circuit in wiring B. Defective agitator motor.	Call for service. Call for service
Gate does not open. Agitator does not turn.	A. No power or CO ₂ .	Plug in unit. Replace CO ₂ . Call for service.
Gate does not open or is sluggish. Agitator turns.	A. Defective gate cylinder. B. Excessive pressure against gate slide.	Call for service. Call for service.
Slushy ice. Water in ice bin.	A. Blocked drain. B. Unit not level. C. Poor ice quality due to water quality or icemaker problems. Improper use of flaked ice.	Clean ice bin and flush drain with warm water. Call for service. Call for service. Call for service.
Beverages do not dispense.	A. No 24 volt power to the valve. B. No CO ₂ pressure.	Plug in unit Replace CO ₂ . Call for service.
Beverages too sweet	A. Carbonator not working. B. No CO ₂ pressure in carbonator. C. Valve ratio requires adjusting.	Call for service. Call for service. Call for service.
Beverages not sweet enough.	A. Empty B.I.B. container. B. Valve ratio requires adjusting.	Replace Call for service.
Beverages not cold.	A. No ice in hopper. B. Drains plugged and water standing on coldplate	Fill ice bin. Clean ice bin and flush drain with warm water. Call for service.
Ice does not dispense from gate assembly.	A. Agitator not moving. B. Defective gate cylinder. C. CO ₂ supply disconnected or depleted. D. Agitator motor defective or wired incorrectly.	Call for service. Call for service. Replace CO ₂ . Call for service.
A.B.S. will not enter auto mode.	A. Cup jam detected, possibly from wrong cup in tube and setting too low.	Clear cup jam. Check cup size. Read display. Call for service.
Conveyor will not operate.	A. Cup rest upside down. B. Cup jam detected, possibly from wrong cup in tube and setting too low. C. Conveyor assembly not properly installed.	Call for service. Remove cup. Refill with correct size cups. Reset. Reinstall conveyor.

Automated Beverage System

Troubleshooting – Trouble/Probable Cause Chart

Trouble	Probable Cause	Corrective Action
Not enough ice in the cup.	A. Ice bin empty. B. Defective gate cylinder. C. CO2 supply disconnected or depleted. D. Agitator motor defective or wired incorrectly.	Fill ice bin. Call for service. Reconnect CO2. Replace CO2 cylinder. Call for refill (bulk) Call for service Call for service.
Ice will not dispense.	A. Ice bin empty. B. Defective gate cylinder. C. CO2 supply disconnected or depleted. D. Agitator motor defective or wired incorrectly.	Fill ice bin. Call for service. Reconnect CO2. Replace CO2 cylinder. Call for refill (bulk) Call for service Call for service.
Drinks too foamy.	A. Carbonator pressure too high. Normal operating range should be 80 - 100 P.S.I.	Call for service.
Won't pour drinks.	A. Cup tubes empty.	Refill cup tubes with correct cups.

Automated Beverage System

Wiring Diagram

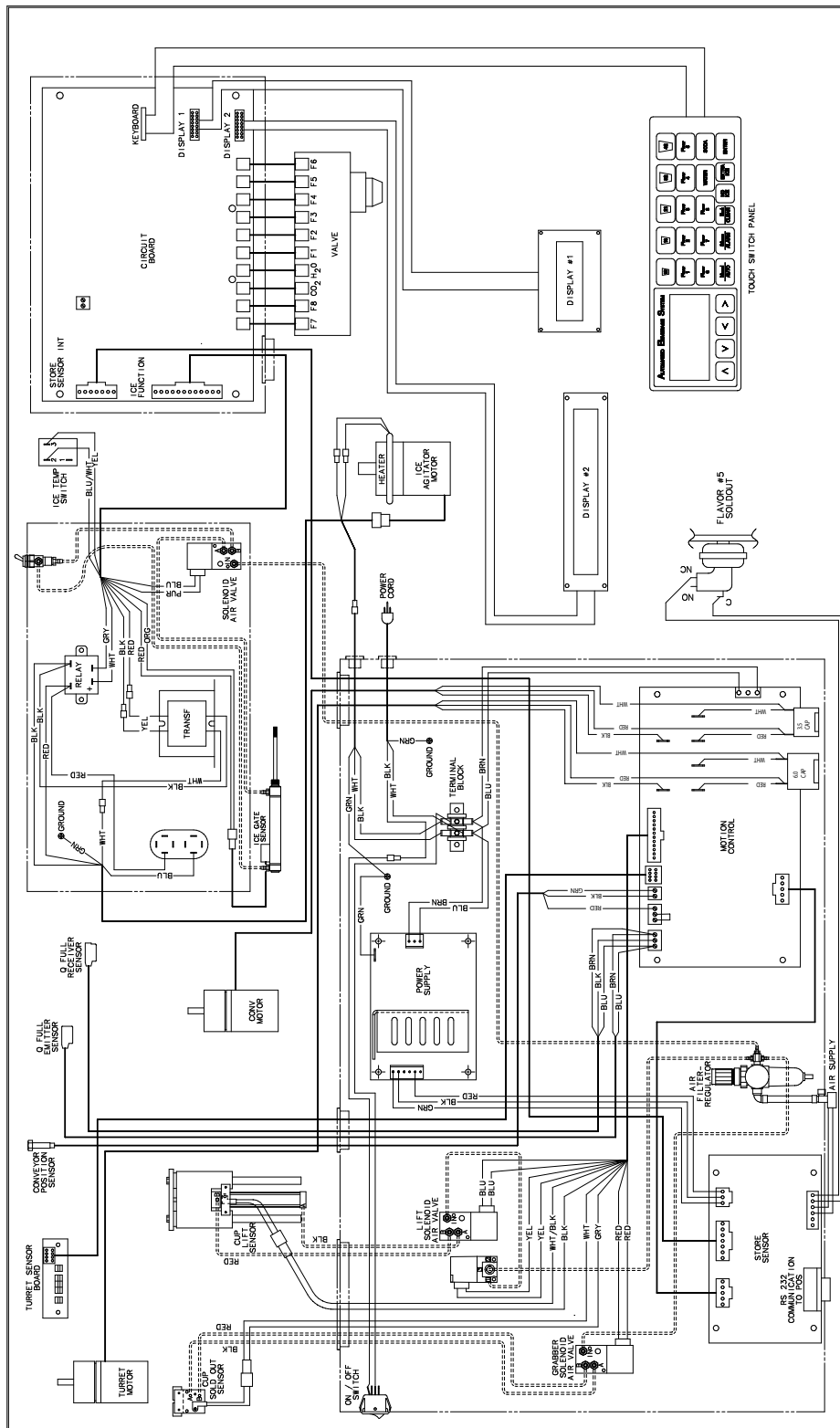

WIRING DIAGRAM 115V

Automated Beverage System

Wiring Diagram

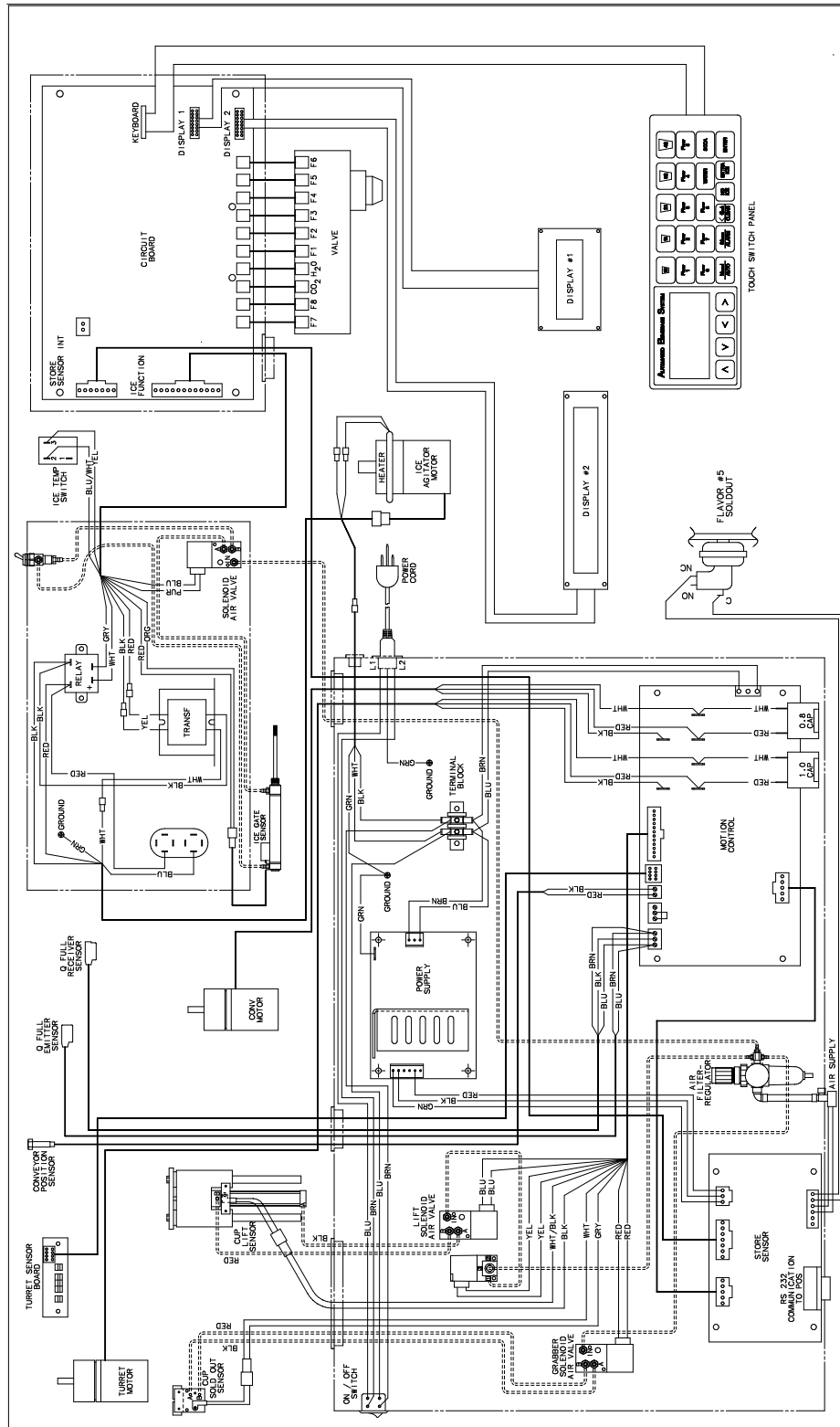

WIRING DIAGRAM 230V

Automated Beverage System

Pneumatic Schematic

