



IMI CORNELIUS INC.
www.cornelius.com

Nordic Ice Maker Model CCM and CCU Series Installation, Start-up and Maintenance Manual



Publication Number: 631806051

Revision Date: April 16, 2010

Revision: F

Visit the IMI Cornelius web site at www.cornelius.com for all your Literature needs.

How To Use This Manual

Cornelius provides this manual as an aid to the service technician in installation and maintenance of the **CCM and CCU Series** cube ice machines. Do not attempt to perform installation, start-up or maintenance unless you have read and fully understand this manual.

If at any time you encounter conditions that are not addressed in this manual, please contact the Cornelius Technical Service Department at:

E-Mail: tech.service@Cornelius.com

Website : www.cornelius.com

Telephone Number

800-238-3600 All Departments

Any Service communication must include:

- Model Number
- Serial number
- A detailed explanation of the problem

Keep this manual for future reference.

The Cornelius CCM and CCU Series Service Parts Manuals are available separately.

Cornelius icemakers and dispensers are not approved for outdoor installation.

WARNING: Always disconnect electrical power and shut off water supply whenever maintenance or repairs are performed on the ice machine and related equipment.

CAUTION: Always wear protective eyewear whenever maintenance or repairs are performed on the ice machine and related equipment.

Table of Contents

Foreward	Page i
Table of Contents	Page ii
Freight Claim Procedure	Page iii
Model Number and Serial Number Format	Page 1
Installation Guidelines	Page 2
Remote Condenser Guidelines	Page 4
Electrical and Plumbing Requirements	Page 6
How the Machine Works	Page 13
Start-Up Procedure	Page 14
General Maintenance	Page 16
Cleaning Procedure	Page 17
Cabinet Care	Page 18
Winterizing Procedure	Page 19
Maintenance Record	Page 20

Freight Claims Important!

Inspect Promptly

This merchandise has been carefully inspected and packed in accordance with the carrier's packing specifications. Responsibility for safe delivery has been assumed by the carrier. If loss or damage occurs, you as the consignee must file a claim with the carrier and hold the container for carrier's inspection.

Visible Loss or Damage

Any external evidence of loss or damage must be fully described and noted on your freight bill or express receipt and signed by the carrier's agent. The claim should be filed on a form available from the carrier.

Concealed Loss or Damage

If loss or damage does not appear until merchandise has been unpacked, make a written request for inspection by the carrier within 15 days of the delivery date. Then file a claim on a form from the carrier.

File Claim Without Delay

Do Not Return Damaged Merchandise to Cornelius

Model and Serial Number Format

Sample Data Plate

MODEL NUMBER CCM0630RF2
SERIAL NUMBER 87A0708GC004

AC SUPPLY VOLTAGE ~ 208-230 HERTZ 60
 TOTAL LOAD AMPS PHASE 1
 MINIMUM CIRCUIT AMPACITY 13.0 WIRES 2
 MAX FUSE SIZE OR HACR TYPE CIRCUIT BREAKER 15.0
 HEATER WATTS

MOTORS	VOLTS	RLA/FLA	W/HP	LRA
1 COMPRESSOR	208-230	8.7		43.3
1 FAN DRIVE	230	1.7*	1/4HP	
1 HARVEST	230	.1	3W	
1 PUMP	208-230	.3	35W	

RATED POWER CONSUMPTION (KW) 0
 REFRIGERANT R404A CHARGE/CIRCUIT 132 OZ 3736 GRAMS
 NUMBER OF REFRIGERANT CIRCUITS 1
 DESIGN PRESSURES P.S.I. 252 -LO 500 -HI
 BARS 17.7 -LO 35.1 -HI

 LISTED 361P
 US
ICE MAKER WITHOUT STORAGE MEANS LESS CONDENSER

*Fan motor rating on condenser employed must not exceed the above fan motor rating.

IMI CORNELIUS
 MADE IN U.S.A.

 NSE COMPONENT

RATED ENERGY EFFICIENCY (KWH/100 LB) 6.8 (KJ/KG) 555.6
 MINIMUM BIN ENERGY EFFICIENCY (%) NA
 Verified in Accordance With Energy Standard CAN/CSA 742-98 and ARI 810-91 by Underwriters Laboratories Inc.

MODEL NUMBER CCM0630RF2
SERIAL NUMBER 87A0708GC004
 VOLTS/HERTZ/PHASE 208-230/60/1 MAX FUSE SIZE 15.0
 REFRIGERANT R404A CHARGE/CIRCUIT 132 OZ 3736 GRAMS

 LISTED 361P
 US
ICE MAKER WITHOUT STORAGE MEANS LESS CONDENSER

 NSE COMPONENT

The serial number format and machine specifics are detailed on the data plate.

Model Number

CCM 06 30 A H 1 2

Engineering Rev Level
 Voltage: 1=115V, 2=230V, 3=230V 3ph 5=50Hz.
 Cube Size: H=Half Cube, F=Full Cube
 Condenser Type: A=Air, W=Water, R=Remote
 Cabinet Width (in inches)
 Approximate Production X 100 in 24 hours 70°F Air / 50°F Water
 Series: **Cornelius Cuber Modular (U=Undercounter)**

← Large data plate will be placed on the back of the unit.

Serial Number

87 A 0708 GC 004

Sequential Serial Number
 Product Line
 GC=Cuber
 GB=Remote Condenser
 GA= Dispenser
 Date Code, Year Month format. (2007 August 08)
 Revision Level (Internal)
 Manufacturing Facility

← Small data plate will be placed by the service valves.

Note: The date code will change monthly and yearly to reflect the date of manufacture.

Installation Guidelines

For proper operation of the Cornelius ice machine, the following installation guidelines must be followed. Failure to do so may result in loss of production capacity, premature part failures, and may void all warranties.

Reference the installation parameters prior to installing the machine:

Ambient Operating Temperatures

Minimum Operating Temperature: 50°F (10°C)

Maximum Operating Temperature 100°F (38°C), 110°F (43°C) on 50 Hz. Models.

Note: Cornelius icemakers and dispensers are not approved for outdoor installation.

Incoming Water Supply (See Electrical and Plumbing Diagrams for line sizing)

Minimum incoming water temperature: 40°F (4.5°C)

Maximum incoming water temperature: 100°F (38°C)

Minimum incoming water pressure: 20 psi (1.4 bar)

Maximum incoming water pressure: 60 psi (4.1 bar)

Note: If water pressure exceeds 60 psi (4.1 bar), a water pressure regulator must be installed.

Drains

All drain lines must be installed per local codes. Flexible tubing is not recommended. Route bin drain, purge drain and water condenser drain individually to a floor drain. The use of condensate pumps for draining water is not recommended by Cornelius. Cornelius assumes no responsibility for improperly installed equipment.

Note: The purge drain fitting is plastic; DO NOT apply heat to the purge drain area; DO NOT over tighten.

Water Filtration

A water filter system should be installed with the ice machine.

Clearance Requirements

Self-contained air cooled ice machines must have a minimum of 6 inches (15cm) of clearance at the rear, top, and sides of the ice machine for proper air circulation.

Stacking

If the ice machines are to be stacked, refer to the instructions in the stacking kit. Cornelius does not endorse stacking air-cooled ice machines.

Dispenser Application

A thermostatic bin control kit should be installed if the CCM Series ice machine is placed on a dispenser. A bin top may or may not be required. **(Exception is the CHD22 and CHD30 Series Dispenser)**

Electrical Specifications

Refer to the serial plate at the rear of the ice machine to make sure proper voltage and circuit breaker size have been supplied. Make sure the machine is on a dedicated circuit. European installations require that the electrical supply fixed wiring must be provided with a disconnect means having a separation of at least 3mm in all poles. The ice machines are provided without an electrical cord set and are designed and agency approved to be permanently connected.

The 115 volt Undercounter series ice makers are supplied with an electrical cord, all other ice makers will need to be installed and wired per local electrical codes.

CAUTION: Electrical connection must be made or a cord installed by a qualified electrician or there is danger of an electrical fire.

Adjustments

Level the machine within 1/8 inch in all directions.

Check the bin control for proper adjustment.

Check the water in the water trough for proper level.

Check the ice bridge for proper thickness.

Check the water regulating valve adjustment if water cooled.

Secure the machine on top of the bin or dispenser.

Attach the ice machine to the bin with the mounting straps provided with the bin or dispenser. Insure that the back of the ice machine is flush with the back of the bin. Proper functioning of the bin door requires the bin door, when it is opened, to be in a stable position.

If the ice machine is too far forward on the bin, the opened door may not be stable, resulting in an unexpected closing of the bin door. If the ice machine is to be mounted on a bin or dispenser other than a Cornelius, refer to the manufacturers instructions for machine mounting. Cornelius will not be responsible for damage or injury that results from unexpected closing of the bin door as a result of the ice machine being too far forward on the bin.

If the ice machine is to be stacked on top of another ice machine, a stacking kit will need to be installed. Refer to the installation instructions included with the stacking kit.

Important!

A water filtration system should be installed with all ice machines. Check the filter manufacturer's instructions for proper installation.

All water supply lines must be installed per local codes. Use 1/4 inch O.D. minimum on air cooled machines. On water cooled machines 3/8 inch O.D. minimum tubing must be run to the condenser. The water supply for the float can "T" off from the condenser line using 1/4 inch O.D. minimum tubing. Make 2 coils of extra tubing so that the machine can be pulled away from the wall if service is needed.

All drain lines must be installed per local codes. The purge drain should be a minimum of 5/8 inch O.D. tubing. The condenser drain on water cooled units should be 3/8 inch O.D. minimum. The drain line fittings on Cornelius bins are 3/4 FPT. The bin drain should be a minimum of 3/4 inch O.D. Cold water drains should be insulated to prevent condensation from forming.

Warning!

Do not apply heat directly to the back of bin as damage may occur to plastic parts.

Do not over-tighten the purge drain fitting as damage may occur to plastic parts.

Connect power supply to the terminal block in the control box or at the rear junction box if equipped.

Ensure the machine is level within 1/8 inch in all directions.

Remove any shipping or packaging material.

If the machine has a remote condenser, reference the Remote Condenser Installation Guidelines.

Once the machine has been installed, follow the start-up procedures.

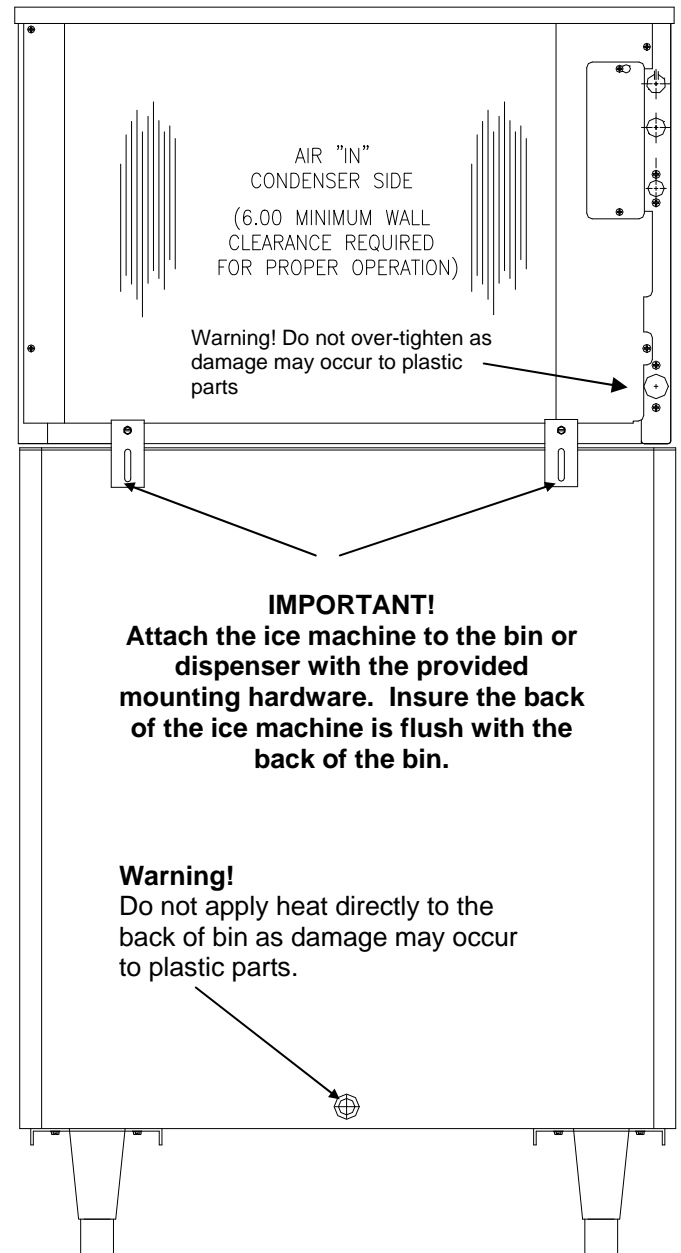

Remote Condenser Installation

For proper operation of the Cornelius ice machine, the following installation guidelines must be followed. Failure to do so may result in loss of production capacity, premature part failure, and may void all warranties.

Use the following for planning the placement of the remote condenser relative to the ice machine.

Location Limits: Remote condenser location must not exceed ANY of the following:

- Maximum rise from the ice machine to the remote condenser is 35 physical feet.
- Maximum drop from the ice machine to the remote condenser is 15 physical feet.
- Physical line set maximum length is 75 feet.
- Calculated line set length maximum is 100 feet.
- Ambient operating temperatures: -20°F (-28.9°C) to 120°F (48.9°C)

Calculation Formula

- Drop = dd x 6.6 (dd = distance in feet)
- Rise = rd x 1.7 (rd = distance in feet)
- Horizontal Run = hd x 1 (hd = distance in feet)
- Calculation: Drop(s) + Rise(s) + Horizontal Run = dd+rd+hd=Calculated Line Length

Configurations that do NOT meet these requirements must receive written authorization from Cornelius. This includes multipass or rack system remote condensers.

Do NOT:

- Route a line set that rises, then falls, then rises.
- Route a line set that falls, then rises, then falls.

Remote Condenser Location:

Limited to a 25, 40, 45, 60 or a 75 foot length of precharged refrigerant tubing connecting the ice machine to the remote condenser. The remote condenser must be above or level with the ice machine. Select the best available location, protecting the remote condenser from extremes of dirt, dust and sun. Meet all applicable building codes. Usually the services of a licensed electrician are required.

Roof Attachment:

1. Install and attach the remote condenser to the roof of the building, using the methods and practices of construction that conform to the local building codes, including having a roofing contractor secure the remote condenser to the roof.
2. Have an electrician connect the remote condenser fan motor wires to the ice machine, using the junction box at the back of the ice machine.

Precharged Line Set Routing

CAUTION: Do not connect the precharged tubing until all routing and forming of the tubing is complete. See the coupling instructions for connecting information.

1. Each set of precharged tubing refrigerant lines consists of a 3/8 diameter liquid line and a 1/2 inch diameter discharge line. Both ends of each line have quick connect couplings, one end has a Schrader valve connection which goes to the condenser.

Note: The openings in the building ceiling or wall, listed in the next step, are the minimum sizes recommended for passing the refrigerant lines through.

2. Have the roofing contractor cut a minimum hole for the refrigerant lines of 2.50 inch. Check local codes, a separate hole may be required for the electrical power to the condenser.

CAUTION: DO NOT KINK OR CRIMP REFRIGERANT TUBING WHEN INSTALLING IT.

3. Route the refrigerant lines through the roof opening. Follow straight line routing whenever possible. Any excess tubing **MUST** remain within the building.
4. Spiral the excess length of precharged tubing inside the building. Use a horizontal spiral to avoid any traps in the lines.
5. Have the roofing contractor seal the holes in the roof per local codes.

CAUTION: The couplings on the sets of precharged lines are self sealing when installed properly. Carefully follow the instructions in the RC manual.

Remote Condenser Guidelines

The following remote ice makers incorporate the mixing valve in the condenser. This configuration allows up to a 100 foot calculated remote line set run. Reference the diagram below to calculate the maximum 100 foot line set run.

ICE Machine Model Number	Remote Condenser Model Number
CCM2148R*1	RC21002C
CCM1848R*1	RC21002C
CCM1448R*1	RC14002C
CCM1530R*1	RC14002C
CCM1030R	RC08002
CCM0830R	RC08002
CCM0630R	RC06002
CCM0530R	RC05001

Note: * Includes 60 Hz. Single Phase, Three Phase and 50 Hz.

Limitations for new remote machines that have the headmaster mounted in the condenser.

Maximum Rise is 35 feet.

Maximum Drop is 15 feet.

Maximum equivalent run is 100 feet.

Formula for figuring maximum equivalent run is as follows:

Rise x 1.7 + Drop x 6.6 + horizontal run = equivalent run.

Examples: 35 ft. rise x 1.7 + 40 ft. horizontal = 99.5 equivalent feet line run

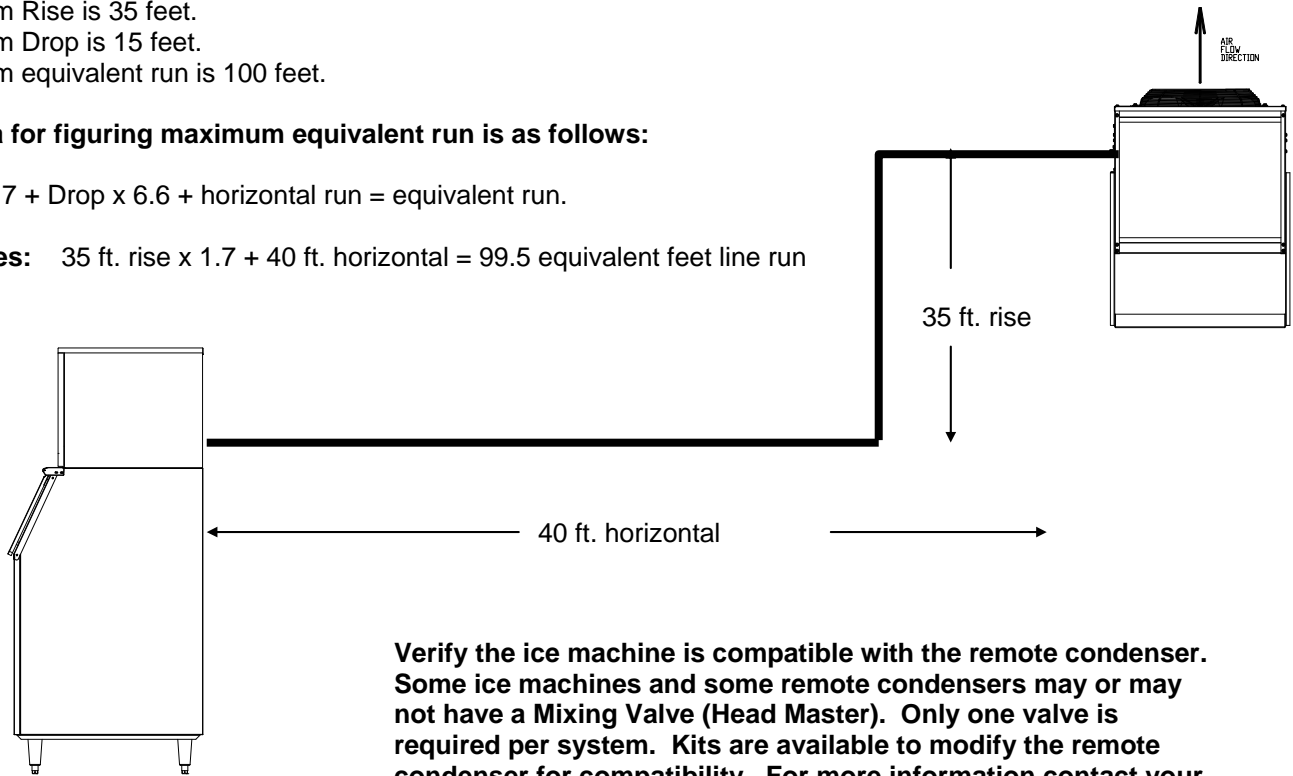

Verify the ice machine is compatible with the remote condenser. Some ice machines and some remote condensers may or may not have a Mixing Valve (Head Master). Only one valve is required per system. Kits are available to modify the remote condenser for compatibility. For more information contact your Cornelius Distributor.

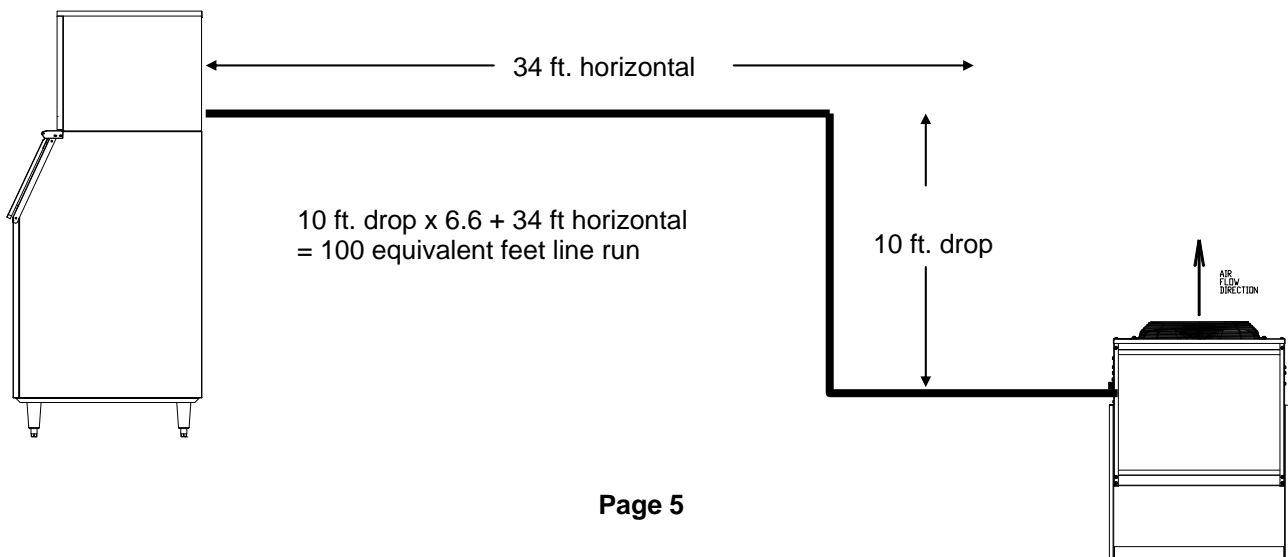

Electrical and Plumbing Requirements: CCU0150, and CCU0220
 (Includes 50Hz. and 230 Volt Units)

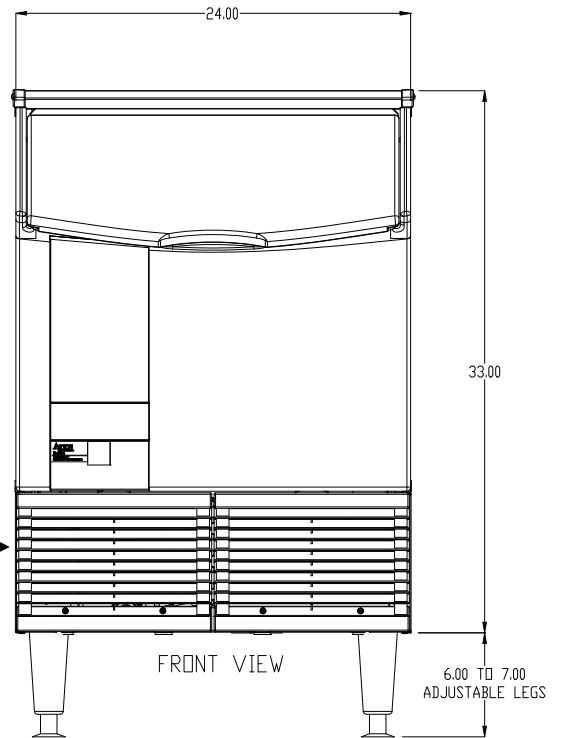
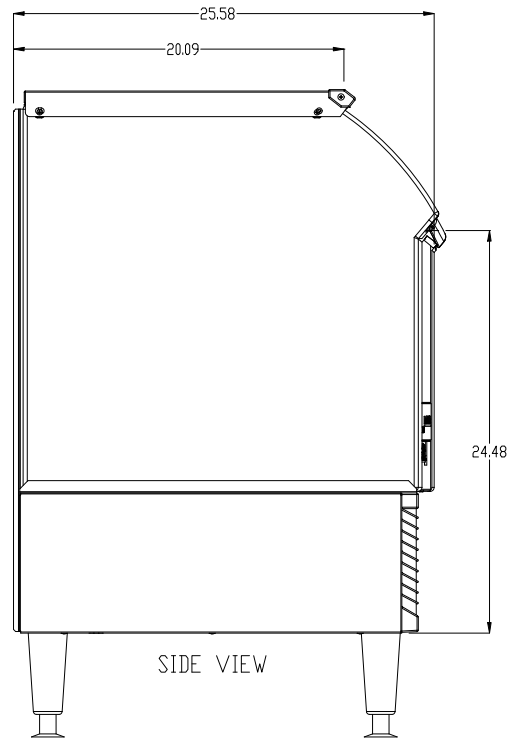
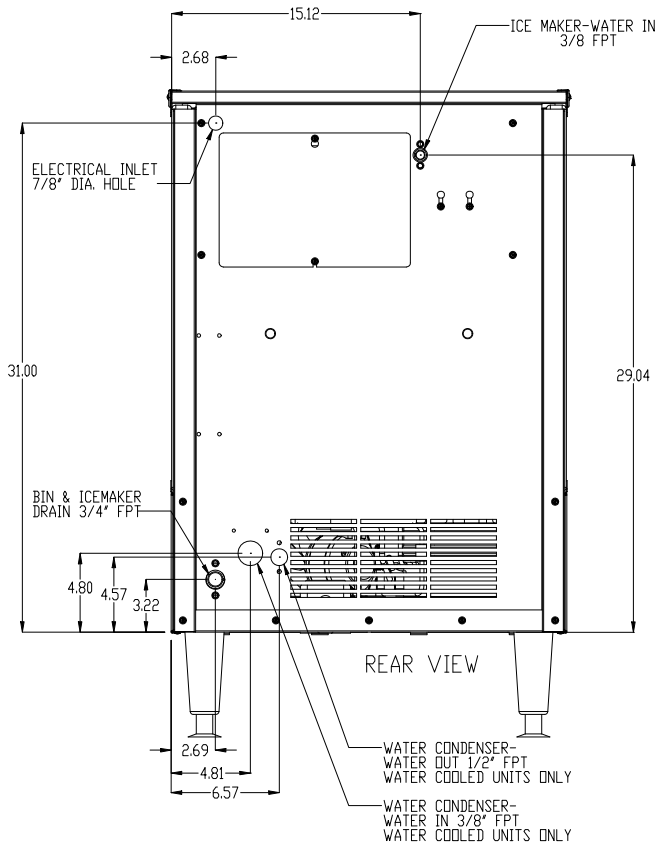

Note: The CCU Undercounter series do not have a splash curtain.

These models utilize a thermostatic bin control in place of a mechanical bin switch.

ON-OFF-WASH Switch is located in the control box.

Remove the grill screws to access the control box.

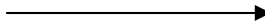

Electrical and Plumbing Requirements: CCU0300 (Includes 50Hz.Units)

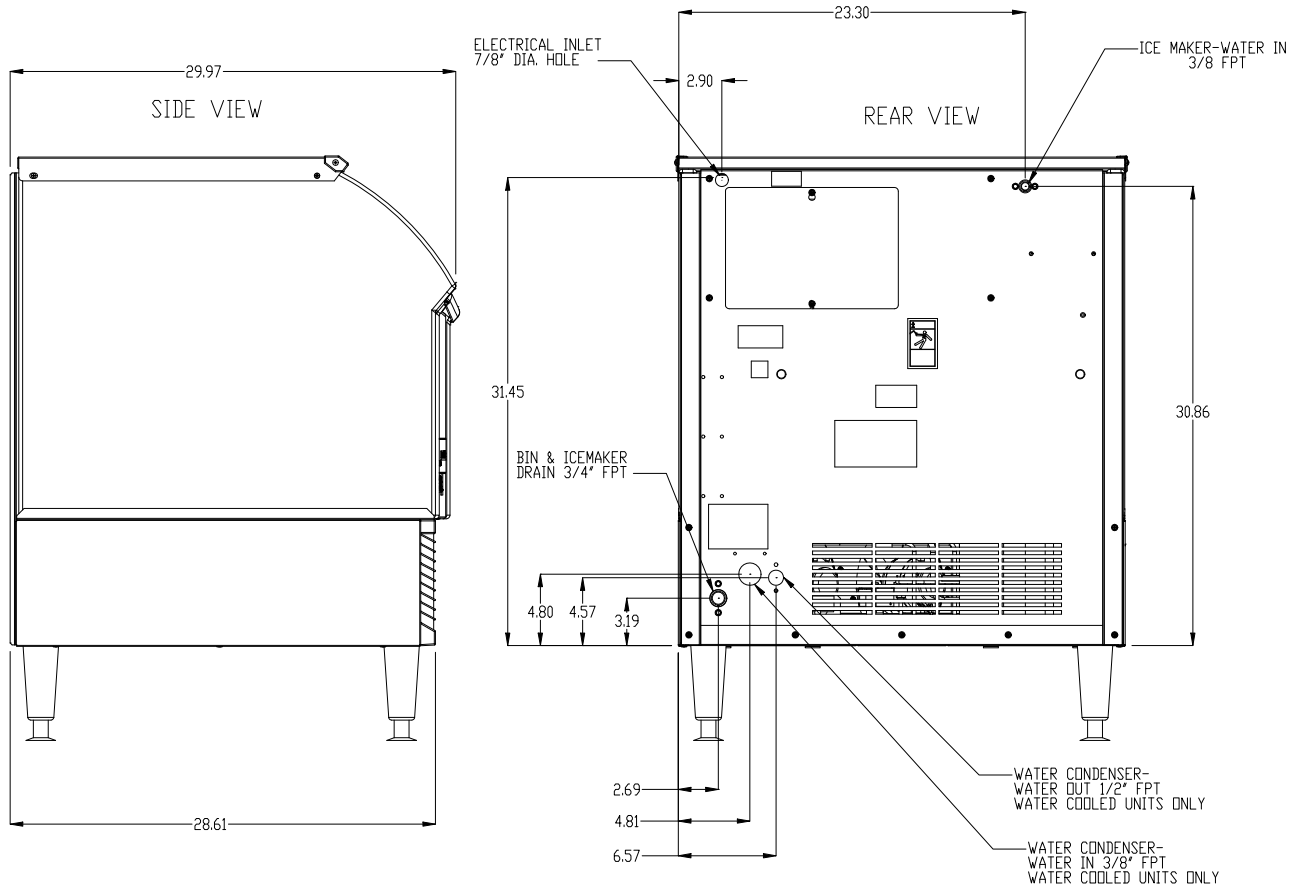

Note: The CCU Undercounter Series do not have a splash curtain.

These models utilize a thermostatic bin control in place of a mechanical bin switch.

ON-OFF-WASH Switch is located in the control box.

Remove the grill screws to access the control box.

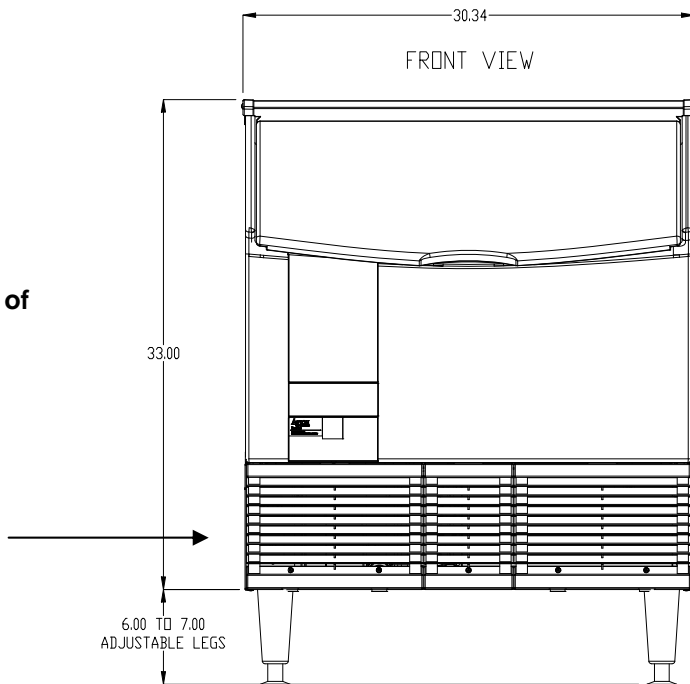

Electrical and Plumbing Requirements: CCM0330, CCM0430, CCM0530, CCM0630
(Includes 50Hz. Units)

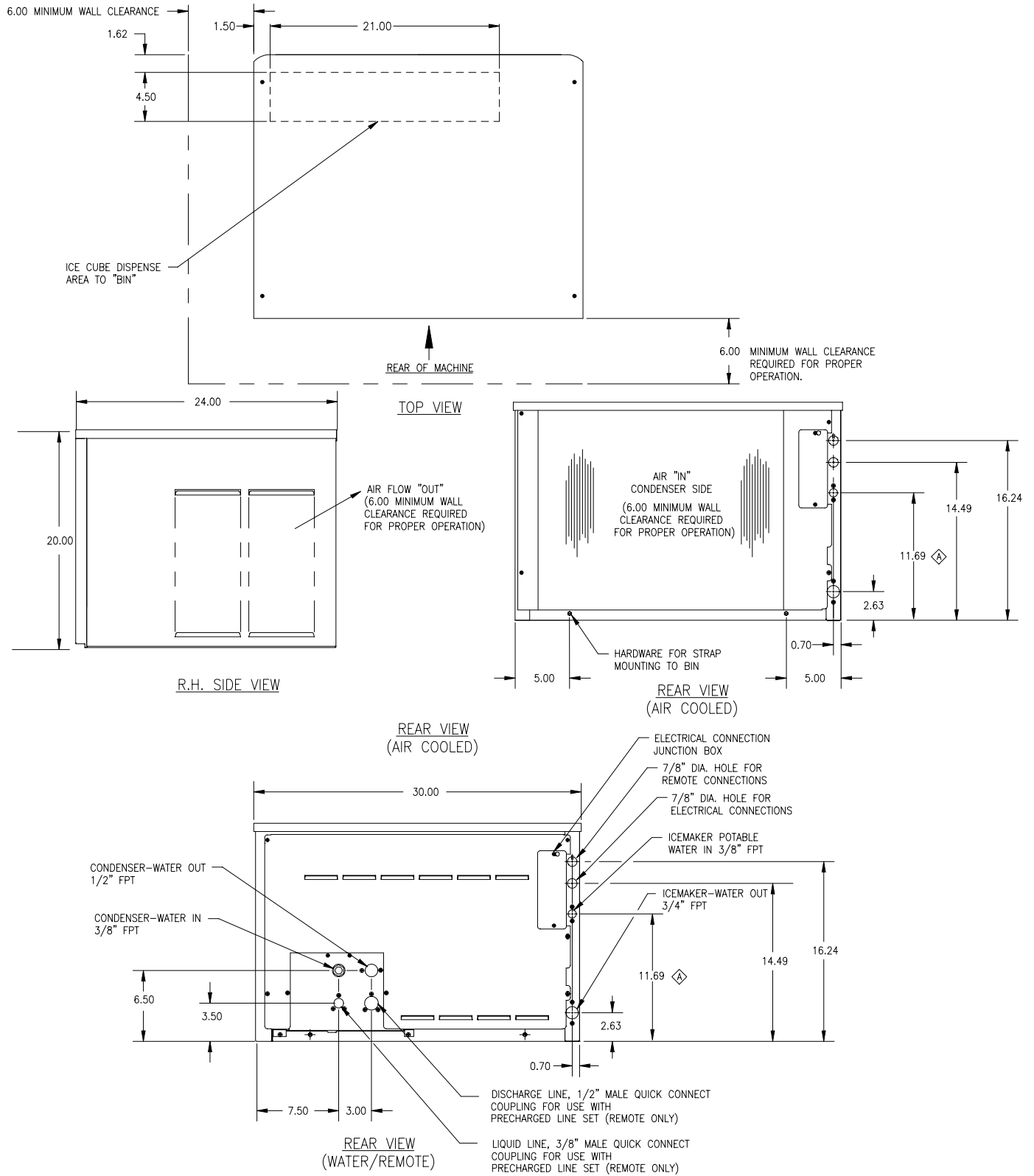

Electrical and Plumbing Requirements: CCM0830 and CCM1030
(Includes 50Hz. And 3 Phase Units)

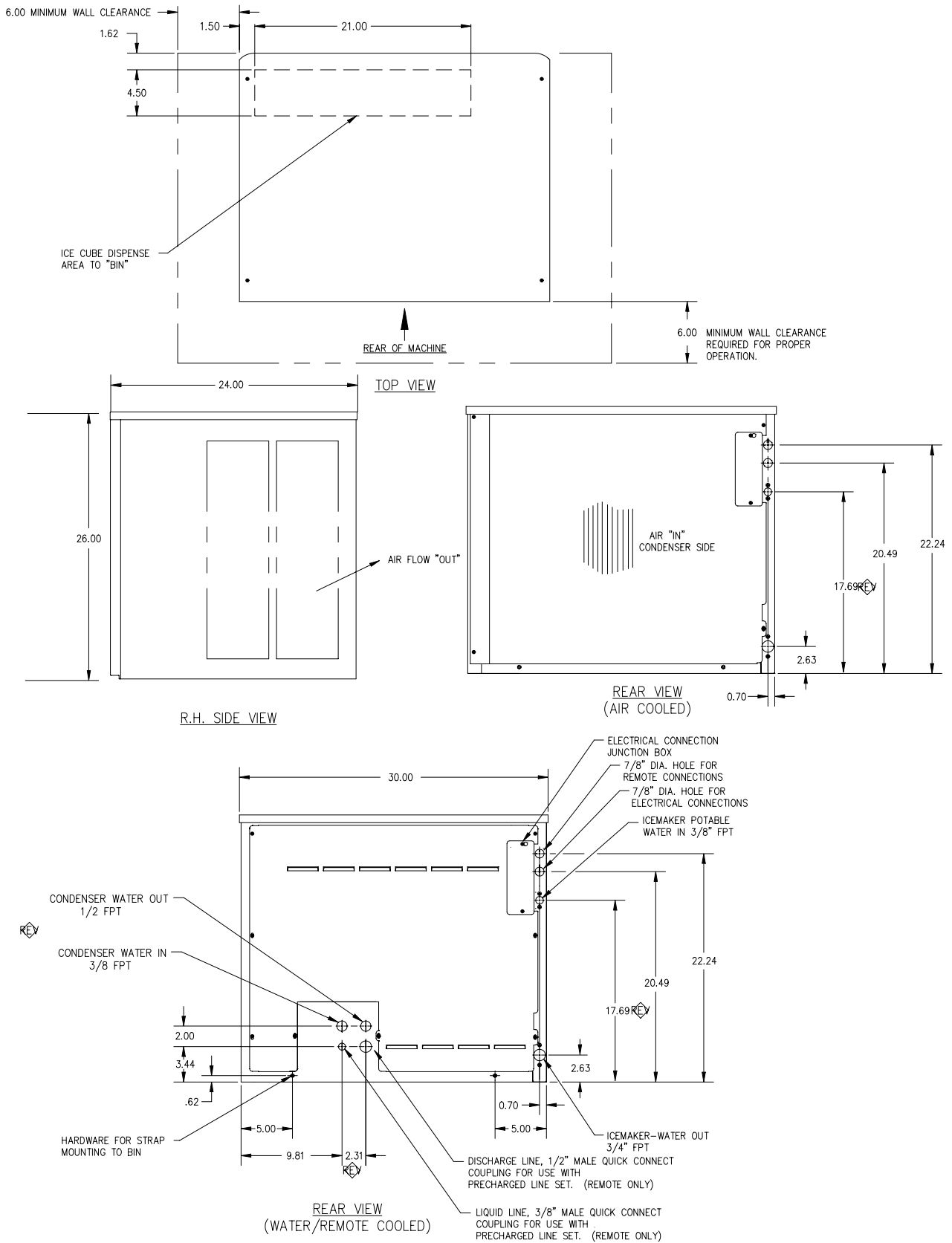

Electrical and Plumbing Requirements: CCM1448, CCM1848 AND CCM2148
(Includes 50Hz. and 3 Phase Units)

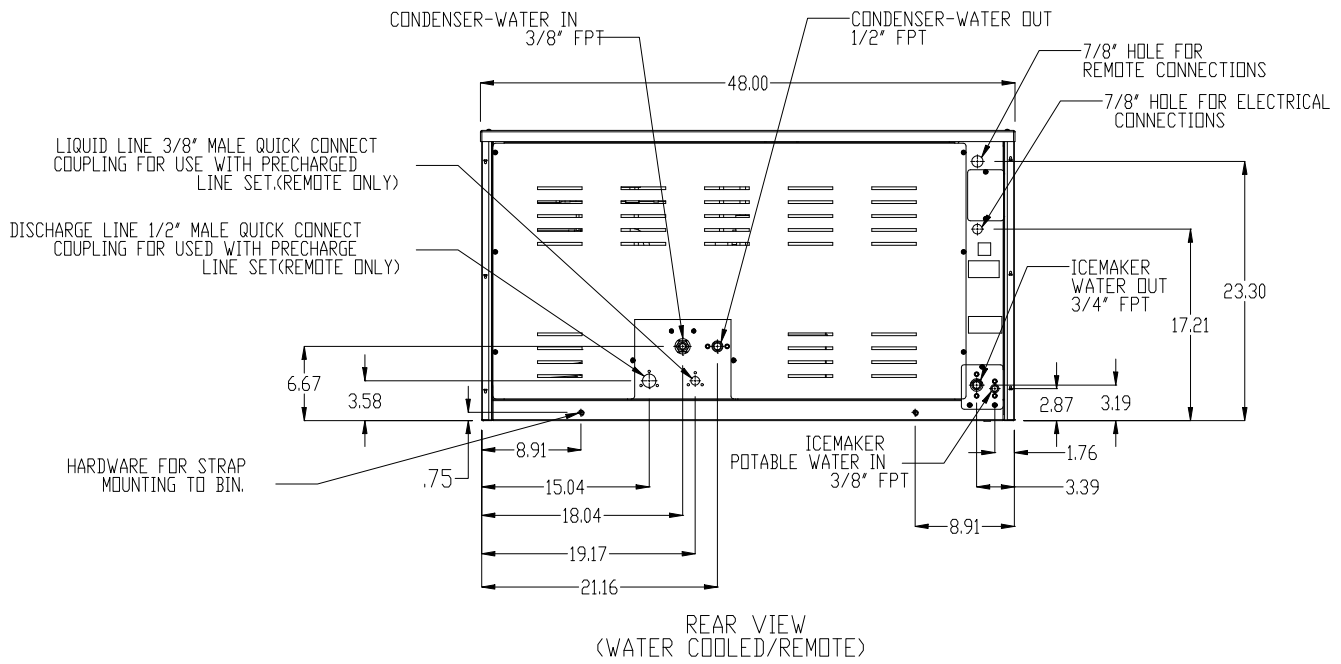
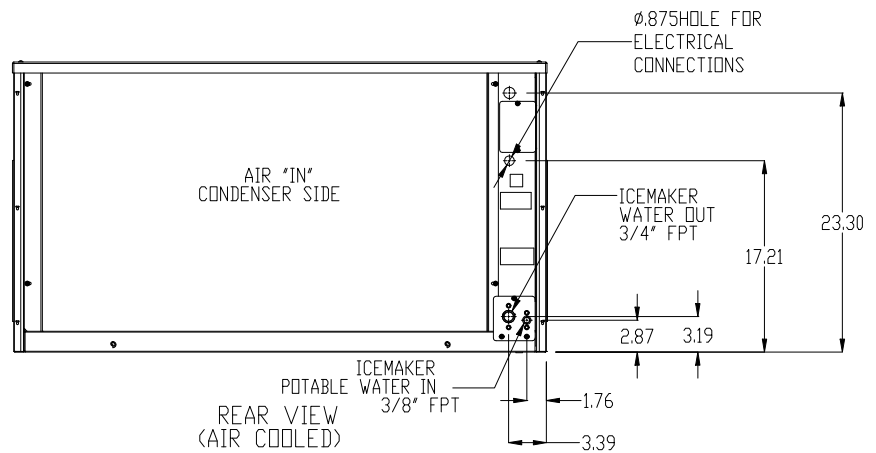
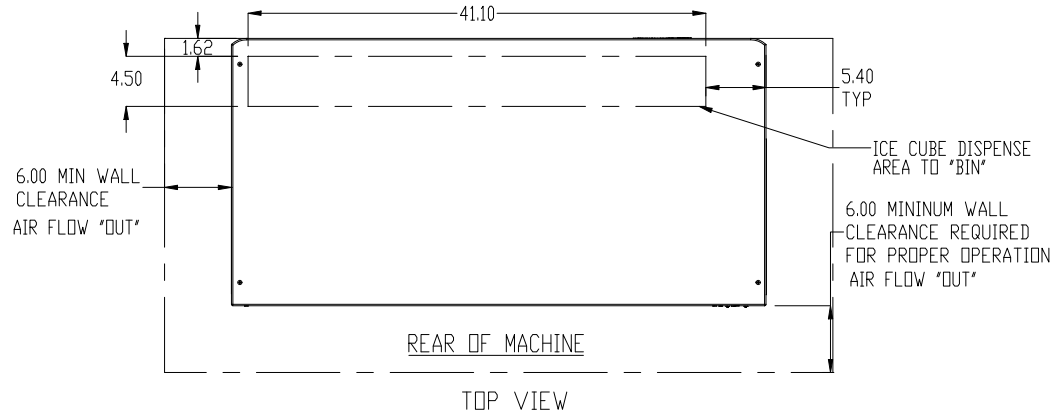

Electrical and Plumbing Requirements: CCM0322 AND CCM0522 (Includes 50Hz.Units)

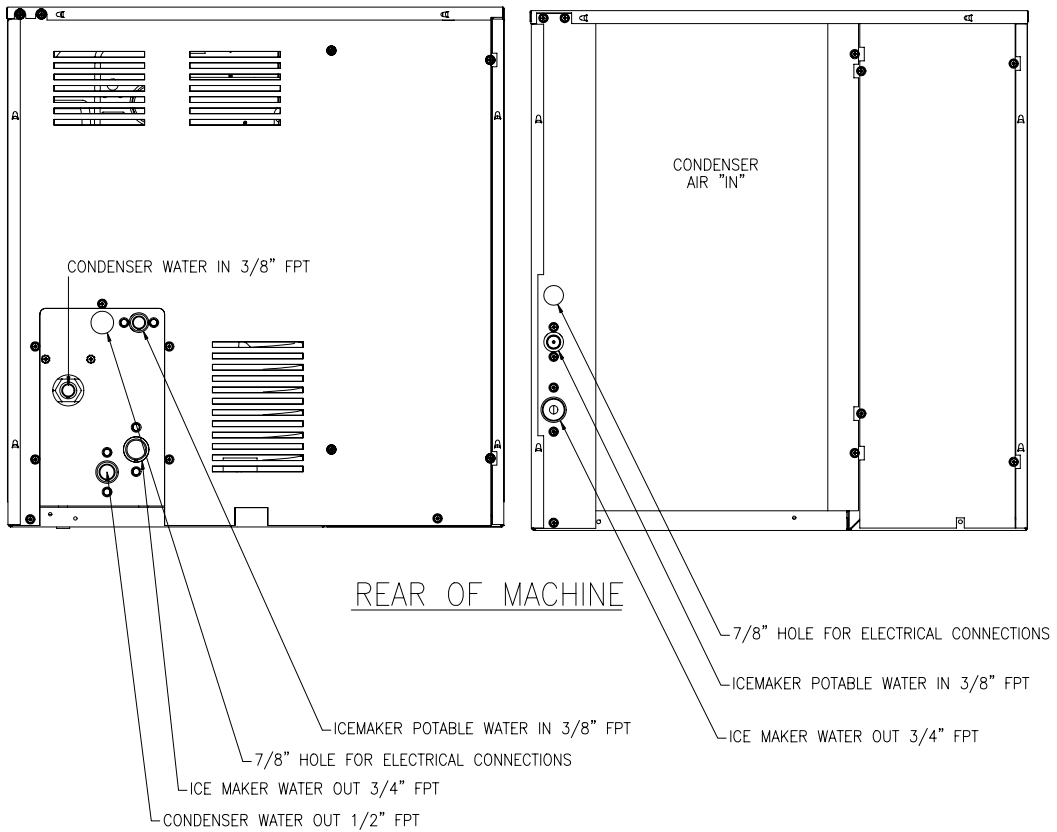
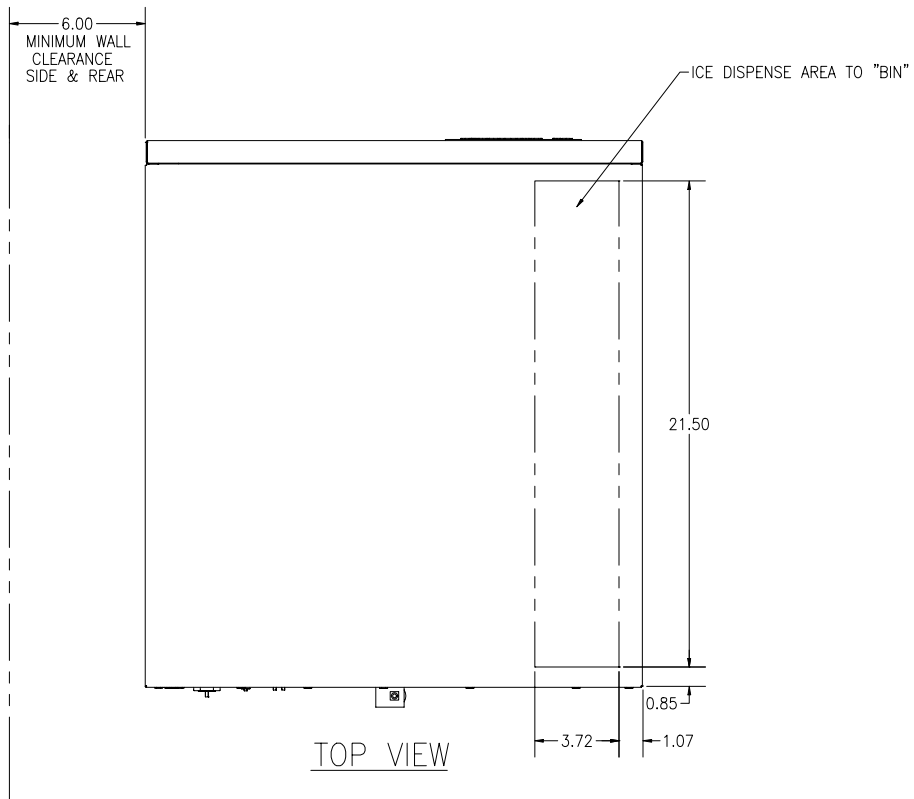

Electrical and Plumbing Requirements: CCM1530 Remote

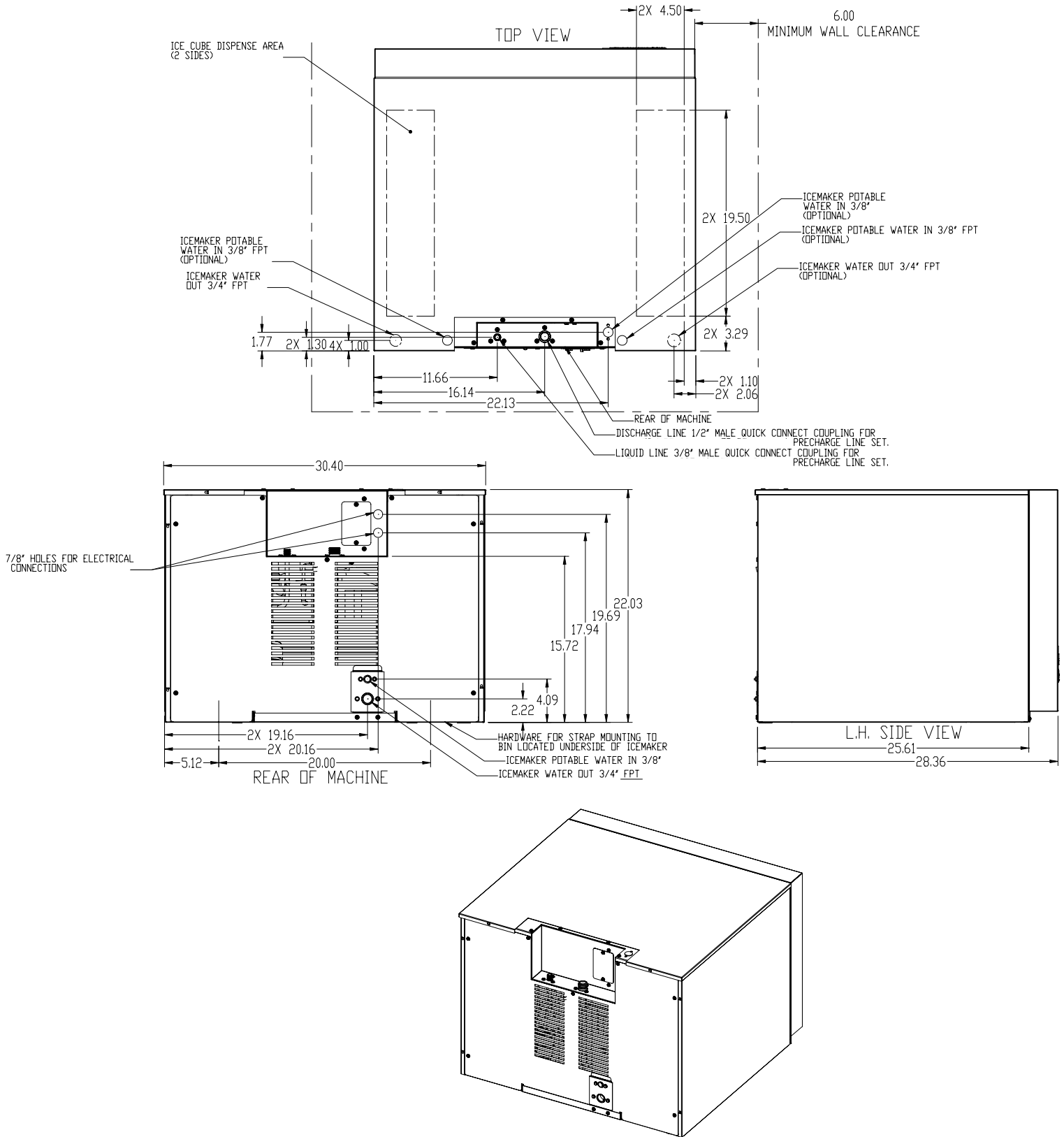

How the Ice Machine Works

A general description of how the **CCM Series** cubers works is given below. With the ICE/OFF/WASH switch in the ICE position, the compressor, water pump and condenser fan motor (when applicable) will energize starting the freeze cycle.

During the freeze cycle, water is circulated over the evaporator(s) where the ice cubes are formed. When the suction pressure has pulled down to the proper cut-in pressure of the timer initiate (pressure control), the contacts will close and energize the time delay module (timer). At this time, the cubes will be close to completion.

The remaining portion of the freeze cycle is determined by the timer setting. The timer is pre-set at the factory to achieve the proper ice bridge thickness but may need to be adjusted upon initial start-up, see Page 14 for timer adjustment.

Once the amount of time on the timer has passed, the control relay will be energized and the machine will enter harvest. Power is now supplied to the water purge valve, hot gas valve, and the harvest motor.

The water purge valve opens, and allows the water pump to purge the water remaining in the water trough, removing impurities and sediment. This allows the machine to produce clear ice cubes and keep mineral build up at a minimum.

The hot gas solenoid opens allowing hot gas to go directly to the evaporator, heating the evaporator and breaking the bond between the evaporator and the ice slab.

The harvest assist motor, which is also energized during harvest, turns a slip clutch, which pushes a probe against the back of the ice slab. Once the evaporator has reached approximately 40°F (4.5°F) in temperature, the slip clutch overcomes the bonding of the ice to the evaporator and pushes the slab of ice off of the evaporator and into the storage bin.

The clutch also actuates a switch that rides on the outer edge of the clutch. When the clutch completes one revolution, the switch is tripped and the machine enters the next freeze cycle.

When ice drops into a full bin during harvest, the splash curtain is held open which activates a bin switch shutting the machine off. When ice is removed from the bin, the splash curtain will close and the machine will come back on.

Note: The CCU Undercounter Series does not have a splash curtain. These models utilize a thermostatic bin control in place of a mechanical bin switch.

Start-Up Procedure

Before starting the machine, make sure the machine is level within 1/8 inch in all directions, the bin or dispenser leg height can be adjusted by rotating the leg foot.

Check the water level in the water trough. It should be approximately 1/2 inch above the top of the water pump impeller housing. The water level can be adjusted by bending the float arm.

Move the ICE-OFF-WASH switch to the ICE position. The switch is located in the control box. Remove the ice machine front panel or remove the lower grill on the under counter models to access the control box.

Check for proper water flow over the evaporator(s). There should be an even flow of water over the evaporator(s).

Check the water regulating valve (water cooled machine) for proper adjustment by measuring the water temperature at the outlet of the condenser. It should be between 100°F and 110°F (38°C and 43°C). Adjust the water regulating valve as required.

As ice begins to form on the evaporators, check the freeze pattern of the ice. Ice should form evenly across the evaporator. Models CCM0830, CCM1030, CCM1848 and CCM2148 machines will have a slight variance from the top to the bottom of the evaporator(s).

Bridge Thickness and Timer Adjustment

Once the ice drops off the evaporator(s) during harvest, check the bridge thickness of the ice slab. The bridge should be 3/16 of an inch on Undercounter and CCM0330 units. The bridge should be 1/8 of an inch on all other units. If the bridge thickness is incorrect, the timer will need adjustment.

The ice bridge thickness is controlled by the freeze timer located in the control box. To check the timer setting, add the seconds of each dipswitch turned to the "ON" position. The number beside the each dipswitch represents seconds. To increase the bridge thickness, increase the timer setting. To decrease the bridge thickness, decrease the timer setting. The freeze timer can be adjusted by sliding one or more switches to either the "ON" or "OFF" position to obtain the desired setting.

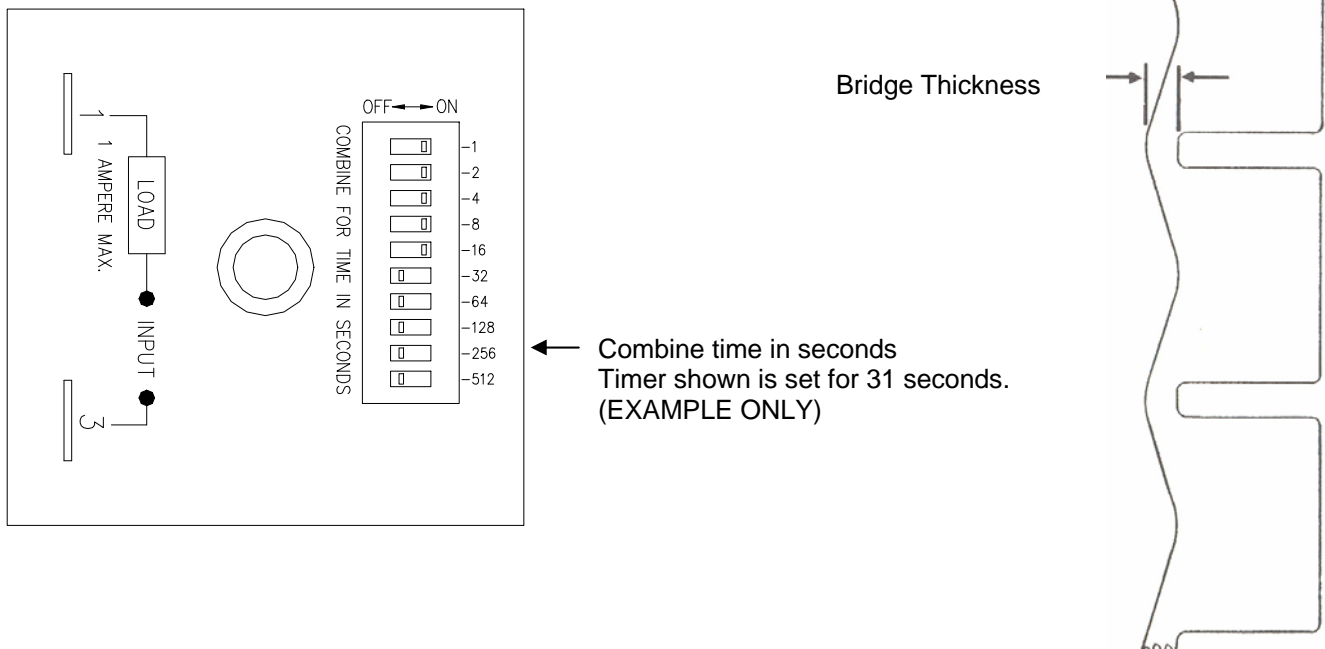

Bin Control Operation

The bin control is used to shut the machine off when the bin fills with ice. The bin control must be checked upon installation or initial start-up and when performing maintenance.

There is one bin switch for each evaporator. The actuator arm of the bin switch comes in contact with the splash curtain. When the bin is full of ice, the splash curtain is held open when ice drops off of the evaporator. This releases the pressure of the bin switch actuator arm allowing the switch to open.

Single evaporator machines: (Including the CCM1530) If the bin switch opens during freeze or the first part of harvest, relay 2 bypasses the bin switch and the machine will continue running. If the bin switch is opened during harvest when the cam switch is lifted onto the high part of the cam, the machine will shut off. When the bin switch closes again, the machine will restart.

Dual evaporator machines: If either bin switch opens during the freeze cycle, the machine will shut off. Relay 1 and relay 2 will bypass the bin switches during defrost. If either bin switch is open when the machine returns to the freeze cycle, the machine will shut off.

Undercounter machines: A thermostatic bin control is used on the undercounter models. The bin thermostat is located in the control box with a capillary tube, which is in a brass thermo-well mounted to the water trough. When ice comes in contact with the capillary tube thermo-well, the bin thermostat opens and the machine will shut off.

Bin Control Adjustment

All Models (Except Undercounter Models): Check the bin switch for proper adjustment by swinging the bottom of the curtain away from the evaporator. Slowly bring the curtain towards the evaporator. The switch should close when the bottom edge of the curtain is even with the outer edge of the water trough. Adjust the switch by loosening the nuts that hold the switch in place. Move the switch to the proper position and retighten the nuts. Recheck the adjustment.

Undercounter Models and CCM1530

Hold ice against the brass thermal-well making sure the ice is in contact with at least 6 inches (15 cm) of the thermal-well. The bin control should open in approximately 1 minute. Remove the ice. The bin control should close in

approximately 3 minutes. If a major adjustment is required, turn the adjustment screw counterclockwise (warmer) until it stops then turn the adjustment screw clockwise (colder) 1/8 of a turn. This should put the control close to the proper adjustment, recheck and make a minor adjustment if needed. If a minor adjustment is required, turn the adjustment screw clockwise (colder) or counterclockwise (warmer).

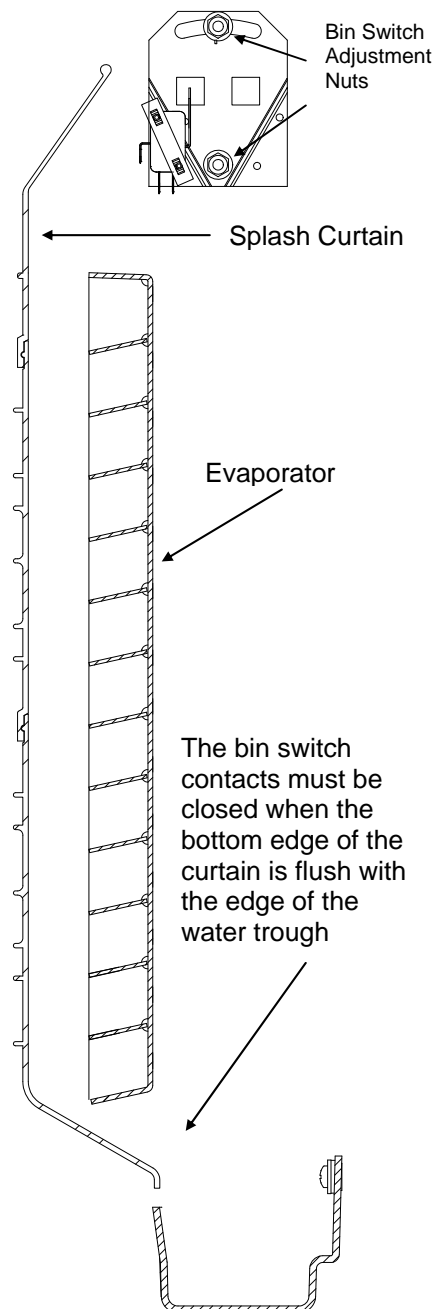
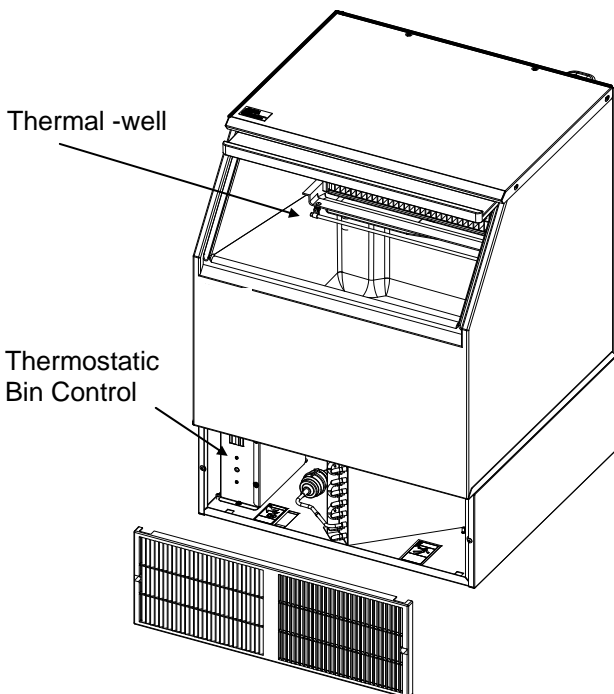

WARNING

Electrical shock and/or injury from moving parts inside this machine can cause serious injury. Disconnect electrical supply to machine prior to performing any adjustments or repairs.

Failure to perform the required maintenance at the frequency specified will void warranty coverage in the event of a related failure.

General Maintenance Procedure

To insure economical, trouble free operation of your machine, it is recommended that the following maintenance be performed every 6 months.

1. Clean the ice-making section per the instructions below. Cleaning should be performed a minimum of every 6 months. Local water conditions may require that cleaning be performed more often.
2. Check ice bridge thickness. See page 14 for proper thickness and adjustment procedure.
3. Check water level in trough. See page 14 for proper water level and adjustment.
4. Clean the condenser (air-cooled machines) to insure unobstructed air flow.
5. Check for leaks of any kind: Water, Refrigerant, Oil, Etc.
6. Check the bin control switch for proper adjustment. See page 15 for bin switch adjustment.
7. Check the water valve (water-cooled machines) for proper adjustment by measuring the water temperature at the outlet of the condenser. It should be between 100°F and 110°F. (38°C and 43°C)
8. Check all electrical connections.
9. Oil the fan motor if the motor has an oil fitting. (Self contained air-cooled models only)
10. Check the water filter (if applicable) and replace if dirty or restricted.
11. Inspect the evaporator water distribution tube to insure even distribution of water across the face of the evaporator.

Ice Machine Cleaning and Sanitizing Instructions

It is the USER'S RESPONSIBILITY to see that the unit is properly maintained. It is always preferable and less costly in the long run, to avoid possible down time by keeping it clean and adjusted as needed; and by replacing worn components before they can cause failure. The following is a list of recommended maintenance that will help keep the machine running with a minimum of problems.

Maintenance and Cleaning should be scheduled at a minimum of twice per year.

Note: Electrical power will be ON when performing the following cleaning instructions.

1. Remove the ice machine front panel.
2. Make sure that all the ice is off of the evaporator. If ice is being made, wait for cycle completion then turn the machine "OFF" at the ICE/OFF/WASH selector switch.
3. Remove or melt all ice in the storage bin.
4. Add recommended amount of approved nickel safe ice machine cleaner to the water trough according to label instructions on the container.
5. Initiate the wash cycle at the **ICE/OFF/WASH** switch by placing the switch in the "**WASH**" position. Allow the cleaner to circulate for approximately 15 minutes to remove mineral deposits.
6. Depress the purge switch and hold until the ice machine cleaner has been flushed down the drain and diluted by fresh incoming water.
7. Terminate the wash cycle at the **ICE/OFF/WASH** switch by placing the switch in the "**OFF**" position. Remove the splash curtain and inspect the evaporator and water spillway to ensure all mineral residue has been removed.
8. If necessary, wipe the evaporator, spillway and other water transport surfaces with a clean soft cloth to remove any remaining residue. If necessary, remove the water distribution tube, disassemble and clean with a bottlebrush. Reassemble all components and repeat steps 4 through 7 as required to remove residue.
9. Turn **OFF** ice machine water supply and clean the water trough thoroughly to remove all scale or slime build-up. If necessary, remove the water trough to reach all splash areas and float.
10. Prepare 1½ to 2 gallons (5.7 to 7.5 liters) of approved (EPA/FDA) sodium hypochloride food equipment sanitizer to form a solution with 100 to 200 max. ppm free chlorine yield.
11. Add enough sanitizing solution to fill the water trough to overflowing and place the **ICE/OFF/WASH** switch to the "**WASH**" position and allow circulation to occur for 10 minutes and inspect all disassembled fittings for leaks. During this time, wipe down all other ice machine splash areas, plus the interior surfaces of the bin, deflector and door with the remaining sanitizing solution. Inspect to insure that all functional parts, fasteners, thermostat bulbs (if used), etc. are in the correct position.
12. Depress the purge switch and hold until sanitizer has been flushed down the drain. Turn **ON** the ice machine water supply and continue to purge to the diluted sanitizing solution for another 1 to 2 minutes.
13. Place the **ICE/OFF/WASH** switch to the "**ICE**" position and replace the front panel.
14. Discard the first two ice harvests.

▲WARNING



**Ice Machine Cleaner contains acids.
KEEP OUT OF THE REACH OF CHILDREN
Refer to ice machine cleaner
manufactures emergency instructions on
container label.**

Cleaning stainless steel

Commercial grades of stainless steel are susceptible to rusting if not properly maintained. It is important that you properly care for the stainless steel surfaces of your ice machine and bin to avoid the possibility of rust or corrosion. Use the following recommended guidelines for keeping your stainless steel looking like new:

1. **Clean the stainless steel thoroughly once a week.** Clean frequently to avoid build-up of hard, stubborn stains. Also, hard water stains left to sit can weaken the steel's corrosion resistance and lead to rust. Use a nonabrasive cloth or sponge, working with, not across, the grain.
2. **Don't use abrasive tools to clean the steel surface.** Do not use steel wool, abrasive sponge pads, wire brushes or scrapers to clean the steel. Such tools can break through the "passivation" layer - the thin layer on the surface of stainless steel that protects it from corrosion.
3. **Don't use cleaners that use chlorine or chlorides.** Don't use chlorine bleach or products like Comet to clean the steel. Chlorides break down the passivation layer and can cause rusting.
4. **Rinse with clean water.** If chlorinated cleansers are used, you must thoroughly rinse the surface with clean water and wipe dry immediately.
5. **Use the right cleaning agent.** The table below lists the recommended cleaning agents for common stainless steel cleaning problems:

<u>Cleaning Activity</u>	<u>Cleaning Agent</u>	<u>Method of Application</u>
Routine cleaning	Soap, Ammonia, Windex, or detergent with water. Fantastik, 409, Spic'nSpan Liquid are also approve for Stainless Steel.	Apply with a clean cloth or sponge. Rinse with clean water and wipe dry.
Removing grease or fatty acids	Easy-Off or similar oven cleaners.	Apply generously, allow to stand for 15-20 minutes. Rinse with clean water. Repeat as required.
Removing hard water spots and scale.	Vinegar	Swab or wipe with clean cloth. Rinse with clean water and dry.

Winterizing Procedures

Important!

Whenever the ice machine is taken out of operation during the winter months, the procedure below must be performed. Failure to do so may cause serious damage and will void all warranties.

1. Turn off water to machine.
2. Make sure all ice is off of the evaporator(s). If ice is being made, initiate harvest or wait for cycle completion.
3. Place the ICE/OFF/WASH switch to the “**OFF**” position. The switch is located in the control box.
4. Disconnect the tubing between the water pump discharge and water distribution tube.
5. Drain the water system completely.
6. On water cooled machines, hold the water regulating valve open by prying upward on the water valve spring with a screwdriver while using compressed air to blow all the water out of the condenser.
7. Remove all of the ice in the storage bin and discard.

