



NORDIC ELITE SERIES CUBE ICE MAKER

CNM 300 lb THROUGH 1400 lb CUBERS

OWNER'S MANUAL



Release Date: April 19, 2018

Publication Number: 548000033

Revision Date: November 27, 2019

Revision: C

Visit the Cornelius web site at www.cornelius.com for all your Literature needs.

Notice

The products, technical information, and instructions contained in this manual are subject to change without notice. These instructions are not intended to cover all details or variations of the equipment, nor to provide for every possible contingency in the installation, operation or maintenance of this equipment. This manual assumes that the person(s) working on the equipment have been trained and are skilled in working with electrical, plumbing, pneumatic, and mechanical equipment. It is assumed that appropriate safety precautions are taken and that all local safety and construction requirements are being met, in addition to the information contained in this manual.

This Product is warranted only as provided in Cornelius' Commercial Warranty applicable to this Product and is subject to all of the restrictions and limitations contained in the Commercial Warranty.

Cornelius will not be responsible for any repair, replacement or other service required by or loss or damage resulting from any of the following occurrences, including but not limited to, (1) other than normal and proper use and normal service conditions with respect to the Product, (2) improper voltage, (3) inadequate wiring, (4) abuse, (5) accident, (6) alteration, (7) misuse, (8) neglect, (9) unauthorized repair or the failure to utilize suitably qualified and trained persons to perform service and/or repair of the Product, (10) improper cleaning, (11) failure to follow installation, operating, cleaning or maintenance instructions, (12) use of "non-authorized" parts (i.e., parts that are not 100% compatible with the Product) which use voids the entire warranty, (13) Product parts in contact with water or the product dispensed which are adversely impacted by changes in liquid scale or chemical composition.

Correct Disposal of this Product



RECYCLE

This marking indicates that this product should not be disposed with other household wastes throughout the EU. To prevent possible harm to the environment or human health from uncontrolled waste disposal, recycle it responsibly to promote the sustainable reuse of material resources. To return your used device, please use the return and collection systems or contact the retailer where the product was purchased. They can take this product for environmental safe recycling.

Trademarks and Copyrights

This document contains proprietary information and it may not be reproduced in any way without permission from Cornelius. This document contains the original instructions for the unit described.

CORNELIUS INC
101 Regency Drive
Glendale Heights, IL
Tel: + 1 800-238-3600

Printed in U.S.

Contact Information

To inquire about current revisions of any documentation or assistance with any Cornelius product, contact:

www.cornelius.com
800-238-3600



TABLE OF CONTENTS

SAFETY INSTRUCTIONS	5
Safety Overview	5
Safety Alert symbol	5
Safety Tips	5
Qualified Service Personnel	5
Safety Precautions	6
Freight Claims	7
INSTALLATION GUIDELINES	8
Ambient Operating Temperature	8
Incoming Water Supply	8
Water Filtration/treatment	8
Drains	8
Clearance Requirements	9
Stacking	9
Dispenser Application	9
Electrical Specifications	9
Remote Condenser Installation	10
Location Limits	10
Remote Condenser Location	10
Pre-charged Line Set Routing	10
Equivalent Run Calculation Examples	12
Electrical And Plumbing Requirements	13
Operation Of The Cnm Series Cuber	17
START-UP PROCEDURE	18
General Maintenance Procedure	19
CLEANING INSTRUCTION FOR CORNELIUS CNM SERIES ICE MACHINES	20
Cabinet Care	22
Chemicals For Descaling And Sanitizing	22
Cleaning Stainless Steel And Aluminum	22
Winterizing Procedures	23
CNM SERIES ICE MAKER FREQUENTLY ASKED QUESTIONS	24
Sequence Of Operations	26
Control Board Features	40
Board Led Sequence During Operation - Initial Freeze Cycle At Start-up	42
Board Led Sequence During Operation - Initial Harvest Cycle At Start-up	43

Board Led Sequence During Operation - Transition From Harvest To Freeze	44
Board Led Sequence During Operation - Bin Full (Curtain Or Stat)	45
Board Led Sequence During Operation - Diagnostics In Freeze Cycle	46
Board Led Sequence During Operation - Diagnostics In Harvest Cycle	47
Water Pump	53
Water Distribution Tube	55
Water Inlet Valve	57
Purge Valve	58
Harvest Assist Assembly/hot Gas Valve	59
Evaporator Assembly	60
High Pressure Cut-out/fan Cycle Control	65
High Temp Safety	66
Fan Motor	66
REFRIGERATION SECTION	67
TECHNICAL SPECIFICATIONS	69
WIRING DIAGRAMS	70

SAFETY INSTRUCTIONS

SAFETY OVERVIEW



- Read and follow **ALL SAFETY INSTRUCTIONS** in this manual and any warning/caution labels on the unit (decals, labels or laminated cards).
- Read and understand ALL applicable OSHA (Occupational Safety and Health Administration) safety regulations before operating this unit.

SAFETY ALERT SYMBOL



This is the safety alert symbol. When you see this in the manual or on the unit, be alert to the potential of personal injury or damage to the unit.

Types of Alerts

 DANGER	Indicates an immediate hazardous situation which if not avoided WILL result in serious injury, death or equipment damage.
 WARNING	Indicates a potentially hazardous situation which, if not avoided, COULD result in serious injury, death, or equipment damage.
 CAUTION	Indicates a potentially hazardous situation which, if not avoided, MAY result in minor or moderate injury or equipment damage.

SAFETY TIPS



- Carefully read and follow all safety messages in this manual and safety signs on the unit. - from Rod's doc
- Keep safety signs in good condition and replace missing or damaged items.
- Learn how to operate the unit and how to use the controls.
- **Do not** let anyone operate the unit without proper training. This appliance is **not** intended for use by very young children or infirm persons without supervision. Young children should be supervised to ensure that they do not play with the appliance.
- Keep your unit in proper working condition and do not allow unauthorized modifications to the unit.

QUALIFIED SERVICE PERSONNEL

 WARNING	Only trained and certified electrical, plumbing and refrigeration technicians should service this unit. All wiring and plumbing must conform to National and Local Codes. Failure to comply could result in serious injury, death or equipment damage.
---	--

SAFETY PRECAUTIONS

This unit has been specifically designed to provide protection against personal injury. To ensure continued protection observe the following:

 WARNING	<p>Disconnect power to the unit before servicing, following all lock out/tag out procedures established by the user. Verify all the power is off to the unit before any work is performed. Failure to disconnect the power could result in serious injury, death or equipment damage.</p>
 CAUTION	<p>Always be sure to keep area around the unit clean and free of clutter. Failure to keep this area clean may result in injury or equipment damage.</p>

Shipping And Storage

 CAUTION	<p>Before shipping, storing, or relocating the unit, the unit must be sanitized and all sanitizing solution must be drained from the system. A freezing ambient environment will cause residual sanitizing solution or water remaining inside the unit to freeze resulting in damage to internal components.</p>
---	--

Unit Location

 CAUTION	<ul style="list-style-type: none"> • This unit is not designed for use in outdoor locations. • The appliance must be placed in a horizontal position. • The appliance is not suitable for installation in an area where a water jet would be used.
--	---

Machine Usage

 CAUTION	<ul style="list-style-type: none"> • This appliance is not intended for use by persons (including children) with reduced physical, sensory or mental capabilities, or lack of experience and knowledge, unless they have been given supervision or instruction concerning use of the appliance by a person responsible for their safety. • Children should be supervised to ensure that they do not play with the appliance.
---	--

FREIGHT CLAIMS Inspect Promptly

This merchandise has been carefully inspected and packed in accordance with the carrier's packing specifications. Responsibility for safe delivery has been assumed by the carrier. If loss or damage occurs, you as the consignee must file a claim with the carrier and hold the container for carrier's inspection.

Visible Loss or Damage

Any external evidence of loss or damage must be fully described and noted on your freight bill or express receipt and signed by the carrier's agent. The claim should be filed on a form available from the carrier.

Concealed Loss or Damage

If loss or damage does not appear until merchandise has been unpacked, make a written request for inspection by the carrier within 5 days of the delivery date, then file a claim on a form from the carrier.

FILE CLAIMS WITHOUT DELAY

DO NOT RETURN DAMAGED GOODS TO CORNELIUS.

HOW TO USE THIS MANUAL

Cornelius provides this manual as an aid to the Refrigeration Service Technician for installation and maintenance of the **CNM** cube ice machines. Do not attempt to perform installation, start-up or maintenance unless you have read and fully understand this manual.

NOTE: Cornelius ice-makers and dispensers are not approved for outdoor installation.

IMPORTANT: Air and water cooled ice machines are hermetically sealed and contain fluorinated greenhouse gas R404A Refrigerant (GWP 3922).

For a Service Provider,

Please contact the Cornelius Service Department at 800-238-3600 or tech.service@cornelius.com

Keep this manual for future reference

The CNM Series Service Parts Manuals are available separately.



WARNING

Always disconnect electrical power and shut off water supply whenever maintenance or repairs are performed on the ice machine and related equipment.



CAUTION

Always wear protective eye wear whenever maintenance or repairs are performed on the ice machine and related equipment.

Cornelius Warranty

Every Cornelius ice maker is backed by a warranty that provides both parts and labor coverage. To view the warranty details, register products, or check your warranty status visit the "Warranty and Water Filter Registration" page on www.ice.cornelius.com

INSTALLATION GUIDELINES

For proper operation of the ice machine, the following installation guidelines must be followed by **a qualified refrigeration technician**. Failure to do so may result in loss of production capacity, premature part failures, and may **void all warranties**.

Reference the installation parameters prior to installing the machine. Cornelius assumes no responsibility for improperly installed equipment. Excessive time required for service or time for units requiring removal for service of inaccessible equipment will be the sole responsibility of the equipment owner.

This appliance is not to be used by persons (including children) with reduced physical, sensory, or mental capabilities, or lack of experience and knowledge, unless they have been given supervision or instruction. Children shall be supervised and are not to play with the appliance.

AMBIENT OPERATING TEMPERATURE

Minimum operating temperature: 50°F (10°C)

Maximum operating temperature: 100°F (38°C) (60 Hz.), 110°F (43°C) (50 Hz.).

NOTE: Cornelius ice-makers and dispensers are not approved for outdoor installation

INCOMING WATER SUPPLY



WARNING

Connect to unheated potable water supply only (see Electrical and Plumbing diagrams for line sizing).

Minimum incoming water temperature: 40°F (4.5°C)

Maximum incoming water temperature: 100°F (38°C)

Minimum incoming water pressure: 20 psi (1.4 bar, 0.138MPa)

Maximum incoming water pressure: 80 psi (5.5 bar, 0.552MPa)

NOTE: If water pressure exceeds 80 psi (5.5 bar), a water pressure regulator must be installed.

All water supply lines must be installed per local codes. Use 3/8 inch O.D. minimum on air cooled machines. On water cooled machines 3/8 inch O.D. minimum tubing must be run to the condenser. The water supply for the machine can "T" off from the condenser line using 3/8 inch O.D. minimum tubing. Make 2 coils of extra tubing so that the machine can be pulled away from the wall if service is needed.

NOTE: This equipment must be installed with adequate backflow protection to comply with applicable federal state and local codes.

WATER FILTRATION/TREATMENT

A water filter system should be installed with the ice machine. Refer to Cornelius water filter specification sheet.

Reverse Osmosis (RO) water can be very acidic and can attack the evaporator and other metal in the ice machine. Because the RO process removes all minerals and metals from the water it can promote the faster growth of microbial mold and slime. If RO water is used, it is recommended the water pH is verified to be a neutral 7.0 to minimize the corrosive effects. Incorrect cleaners, sanitizers, and RO water that does not have a neutral pH could **void the machine's warranty**.

DRAINS

All drain lines must be installed per local codes. Flexible tubing is not recommended. Route bin drain, purge drain and water condenser drain individually to a floor drain. The use of condensate pumps for draining water is not recommended. **Cornelius assumes no responsibility for improperly installed equipment.**

NOTE: The purge drain fitting is plastic: DO NOT apply heat to purge drain area; DO NOT over-tighten drain connection.

All drain lines must be installed per local codes. The purge drain should be a minimum of 3/4 inch O.D. tubing. The condenser drain on water cooled units should be 1/2 inch O.D. minimum. The drain line fittings on Cornelius bins are 3/4 FPT. The bin drain should be a minimum of 3/4 inch O.D. Cold water drains should be insulated to prevent condensation from forming.

CLEARANCE REQUIREMENTS

Self-contained air-cooled ice machines should have a minimum of 6 inches (15cm) of clearance at the rear, top and sides for proper air circulation and adequate space for serviceability.

Self-contained air-cooled ice machines exhaust air out the top and right side. There are two alternative air exhaust options. Option A (top exhaust bias): minimum of 6 inches (15cm) of clearance at the rear and top of the ice machine for proper function at maximum operating conditions. Option B (side exhaust bias): minimum of 6 inches (15cm) of clearance at the rear and right side of the ice machine with a minimum of 3 inches (7.5cm) of clearance at the top for proper function at maximum operating conditions.

Appropriate space should be allowed for proper serviceability of the machine. Excess time to gain access for serviceability is **not covered under warranty**.

STACKING

Cornelius does not endorse stacking ice machines.

DISPENSER APPLICATION

A thermostatic bin control kit should be installed if the CNM Cube ice machine is placed on a dispenser. A bin top may or may not be required and should be secured to the dispenser.

ELECTRICAL SPECIFICATIONS

Refer to the serial plate at the rear of the ice machine to make sure proper voltage and circuit breaker size have been supplied. Make sure the machine is on a dedicated circuit. European installations require that the electrical supply fixed wiring must be provided with a disconnect means having a separation of at least 3mm in all poles. The ice machines are provided without an electrical cord set and are designed and agency approved to be permanently connected.

NOTE: Units are not approved for GFI outlets.



CAUTION

Electrical connection must be made or a cord installed by a qualified electrician or there is danger of an electrical fire.

Adjustments

Level the machine within 1/8 inch in all directions. Check the water in the Water Sump for proper level.

Check the ice bridge for proper thickness and adjust on Float Switch Housing Assembly as needed.

Check the Water Regulating Valve adjustment if water cooled.

Secure the machine on top of the bin or dispenser. Attach the ice machine to the bin with the mounting straps provided with the bin or dispenser. Insure that the back of the ice machine is flush with the back of the bin. Proper functioning of the Bin Door requires the door, when it is opened, to be in a stable position.

If the ice machine is too far forward on the bin, the opened door may not be stable, resulting in an unexpected closing of the bin door. If the ice machine is to be mounted on a bin or dispenser other than an Cornelius, refer to the manufacturers instructions for machine mounting. Cornelius will not be responsible for damage or injury that results from unexpected closing of the bin door as a result of the ice machine being too far forward on the bin.

REMOTE CONDENSER INSTALLATION

For proper operation of the ice machine, the following installation guidelines must be followed. Failure to do so may result in loss of production capacity, premature part failure, and may **void all warranties**.

Use the following for planning the placement of the remote condenser relative to the ice machine

LOCATION LIMITS

Remote condenser location must not exceed **ANY** of the following:

- Maximum rise from the ice machine to the remote condenser is 35 physical feet.
- Maximum drop from the ice machine to the remote condenser is 10 physical feet.
- Physical line set maximum length is 75 ft.
- Calculated line set length maximum is 100 ft.
- Ambient operating temperatures: -20°F (-28.9°C) to 120°F (48.9°C)

Calculation Formula

Drop = dd x 6.6 (dd = drop distance (ft.))

Rise = rd x 1.7 (rd = rise distance (ft.))

Horizontal Run = hd (hd = horizontal distance (ft.))

Calculated Line Length = Drop + Rise + Horizontal Run

NOTE: Configurations that do NOT meet these requirements must receive written authorization from the manufacturer. This includes multi-pass or rack system remote condensers.

NOTE: Do NOT route a line set that rises, then falls, then rises or a line set that falls, then rises, then falls.

REMOTE CONDENSER LOCATION

Pre-charged line sets are available in 25, 40 or 75 foot length to connect the ice machine to the remote condenser. Select the best available location, protecting the remote condenser from extremes of dirt, dust and sun. Meet all applicable building codes. The services of a licensed electrician may be required.

Roof Attachment

Install and attach the remote condenser to the roof of the building using the methods and practices of construction that conform to the local building codes, including having a roofing contractor secure the remote condenser to the roof.

Have an electrician connect the remote condenser fan motor wires to the ice machine using the junction box at the back of the machine.

PRE-CHARGED LINE SET ROUTING



CAUTION

Do not connect the pre-charged tubing until all routing and forming of the tubing has been completed. See the coupling instructions for connecting information.

NOTE: The openings in the building or ceiling or wall, listed in the next step, are the minimum sizes recommended for passing the refrigerant lines through.

Have a roofing contractor cut a minimum hole for the refrigerant lines of 2.50 inch. Check local codes, a separate hole may be required for the electrical power to the condenser.

CAUTION

Each set of pre-charged tubing refrigerant lines consists of a 3/8 diameter liquid line and 1/2 inch diameter discharge line. Both ends of each line have quick connect couplings, one end of the line set has a Schrader valve connection.

CAUTION

DO NOT KINK OR CRIMP REFRIGERANT TUBING WHEN INSTALLING IT.

NOTE: REMOTE LINES MUST NOT RISE AND DROP IN THE SAME RUN.

Route the refrigerant lines through the roof opening. Follow straight line routing whenever possible. Any excess tubing **MUST** remain inside the building. Spiral the excess length of pre-charged tubing inside the building. Use a horizontal spiral to avoid any traps in the lines. Have the roofing contractor seal the holes in the roof per local codes.

CAUTION

The couplings on the sets of pre-charged lines are self sealing when installed properly. Carefully follow the instructions in the Remote Condenser manual.

The following remote ice makers incorporate the Mixing Valve in the Condenser. This configuration allows up to a 100 foot calculated remote line set run. Reference the diagram on the next page to calculate the maximum 100 ft. line set run. Maximum **actual line set run** is limited to 100 ft. Add 1/4 oz. of refrigerant for each actual foot from 75 to 100 ft. actual line set run.

CNM Machine Model Number	Remote Condenser Model Number
CNM0520/530	RCN1001
CNM0525/535	RCN1061
CNM0636	RCN1061
CNM1126	RCN1061
CNM0630R/0830R/1030R	RCN1061
CNM0835/0836/0837	RCN1061
CNM1135/1136/1137	RCN1061

NOTE: Verify the CNM machine is compatible with the remote condenser. For more information contact your Cornelius distributor.

EQUIVALENT RUN CALCULATION EXAMPLES

Formula for maximum equivalent run:

$$(\text{RISE} \times 1.7) + (\text{DROP} \times 6.6) + \text{HORIZONTAL RUN} = \text{EQUIVALENT RUN}$$

NOTE: NOT TO EXCEED 100 CALCULATED FEET

Rise:

$$(35 \text{ ft.} \times 1.7) + (40 \text{ ft.}) = 99.5 \text{ equivalent feet line run}$$

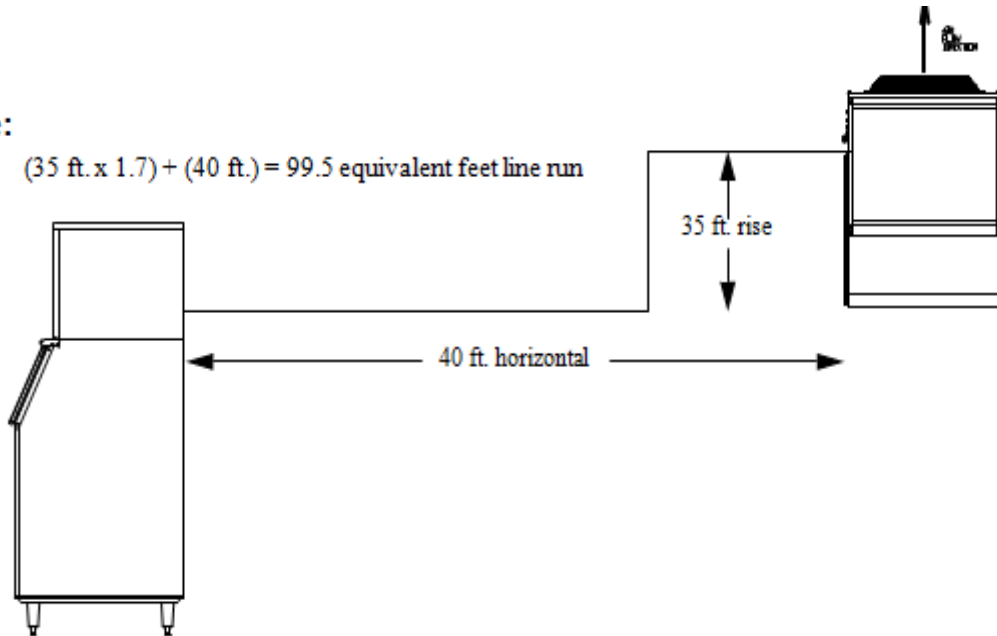

Figure 1.

Drop:

$$(10 \text{ ft.} \times 6.6) + (34 \text{ ft.}) = 100 \text{ equivalent feet line run}$$

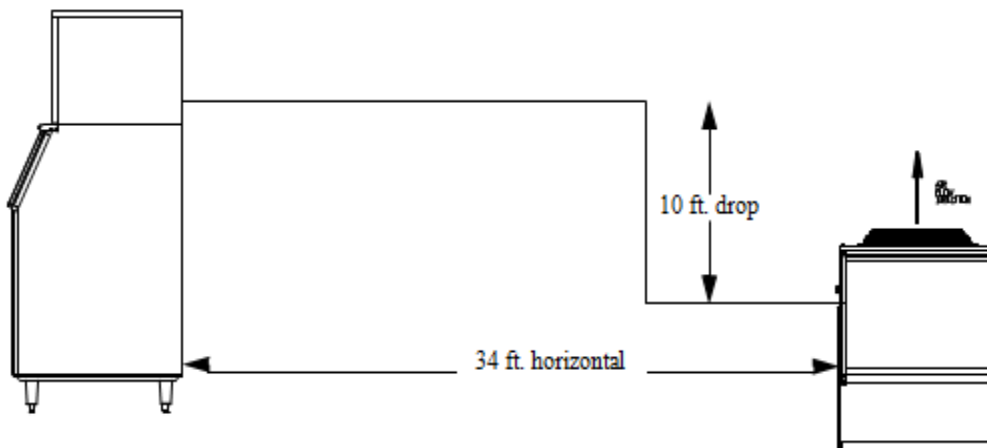

Figure 2.

ELECTRICAL AND PLUMBING REQUIREMENTS 22" CNM SERIES Common Connections

(CNM**22_A*0/5/6)

Air Cooled

NOTE: Air-cooled units require 6"(152mm) for air intake and exhaust.

- A. Ice maker potable water in, 3/8" FPT.
- B. Ice maker water out, 3/4" FPT.
- C. Hole for electrical connections, 7/8".
- D. Electrical junction box, 7/8".

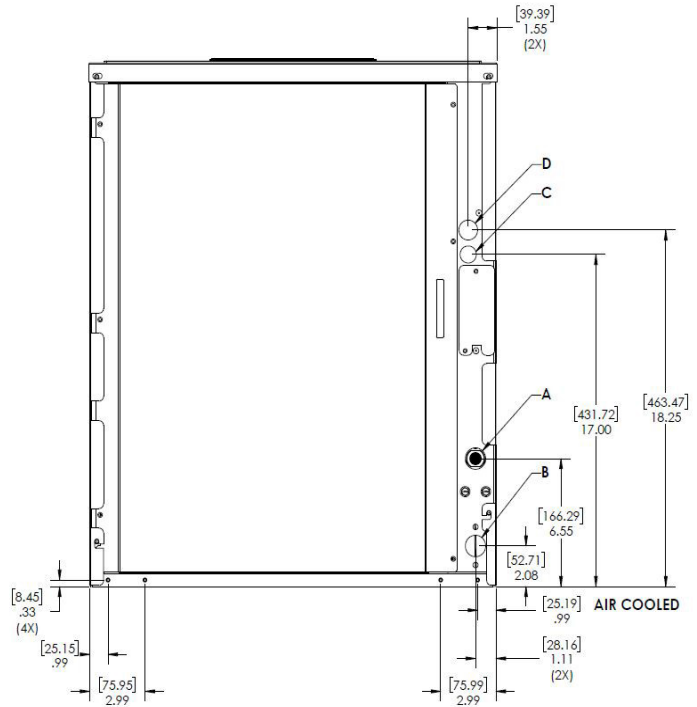

Figure 3.

(CNM**22* W/R*0/5/6)

Water/Remote Cooled

- A. Ice maker potable water in, 3/8" FPT.
- B. Ice maker water out, 3/4" FPT.
- C. Hole for electrical connections, 7/8".
- D. Electrical junction box, 7/8" (remote).
- E. Condenser water in, 3/8" FPT (water only). Discharge line, 1/2" male quick connect coupling for pre-charged line set (remote only).
- F. Condenser water out, 1/2" FPT (water only).
- G. Liquid Line, 3/8" male quick connect coupling for pre-charged line set (remote only).

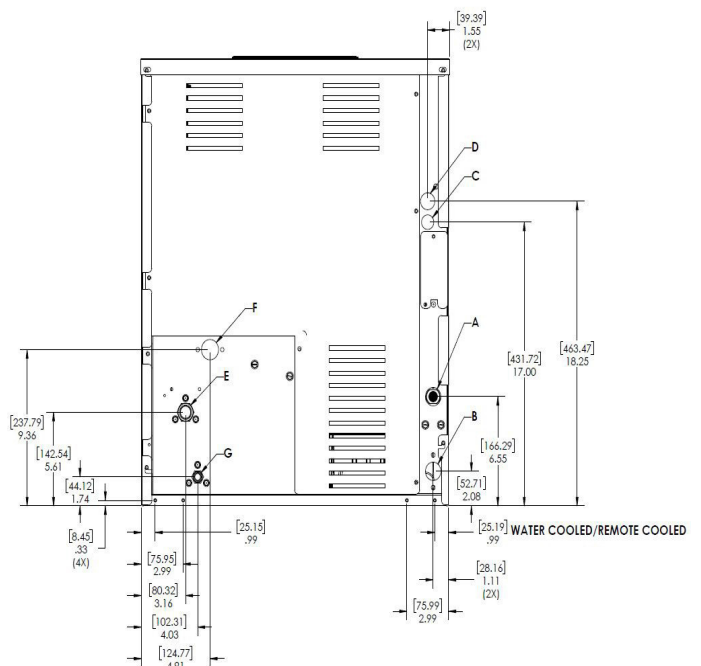

Figure 4.

30" CNM SERIES Common Connections

(CNM**30 A*0/5/6)

Air Cooled

NOTE: Air-cooled units require 6" (152mm) for air intake and exhaust.

- A. Ice maker potable water in, 3/8" FPT.
- B. Ice maker water out, 3/4" FPT.
- C. Hole for electrical connections, 7/8".
- D. Electrical junction box, 7/8".

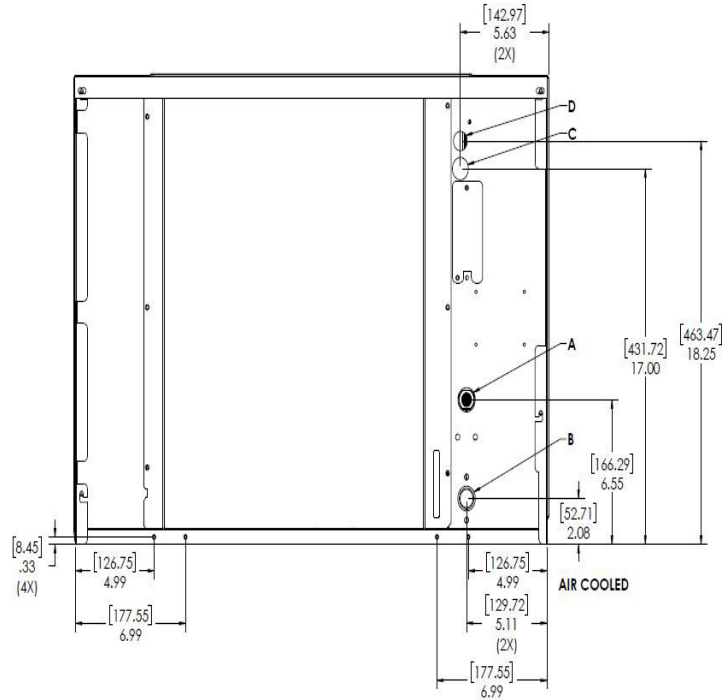

Figure 5.

CNM**30* W/R*0/5/6

Water/Remote Cooled

- A. Ice maker potable water in, 3/8" FPT.
- B. Ice maker water out, 3/4" FPT.
- C. Hole for electrical connections, 7/8".
- D. Electrical junction box, 7/8" (remote).
- E. Condenser water in, 3/8" FPT (water only). Discharge line, 1/2" male quick connect coupling for pre-charged line set (remote only).
- F. Condenser water out, 1/2" FPT (water only).
- G. Liquid Line, 3/8" male quick connect coupling for pre-charged line set (remote only).

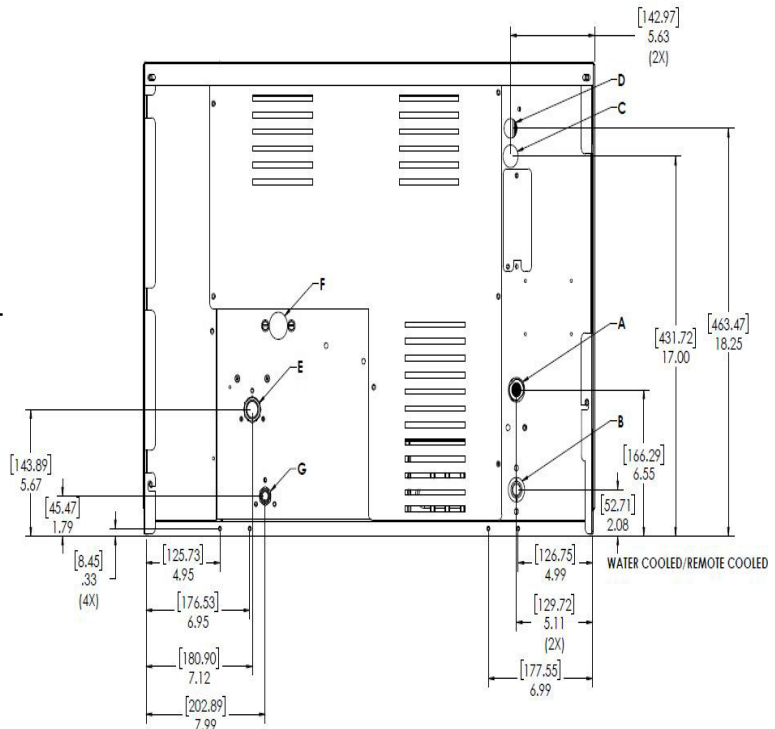

Figure 6.

48" CNM SERIES Common Connections

(CNM**48A*6)

Air Cooled

NOTE: Air-cooled units require 6"(152mm) for air intake and exhaust.

- A. Ice maker potable water in, 3/8" FPT.
- B. Ice maker water out, 3/4" FPT.
- C. Hole for electrical connections, 7/8".
- D. Electrical junction box, 7/8".

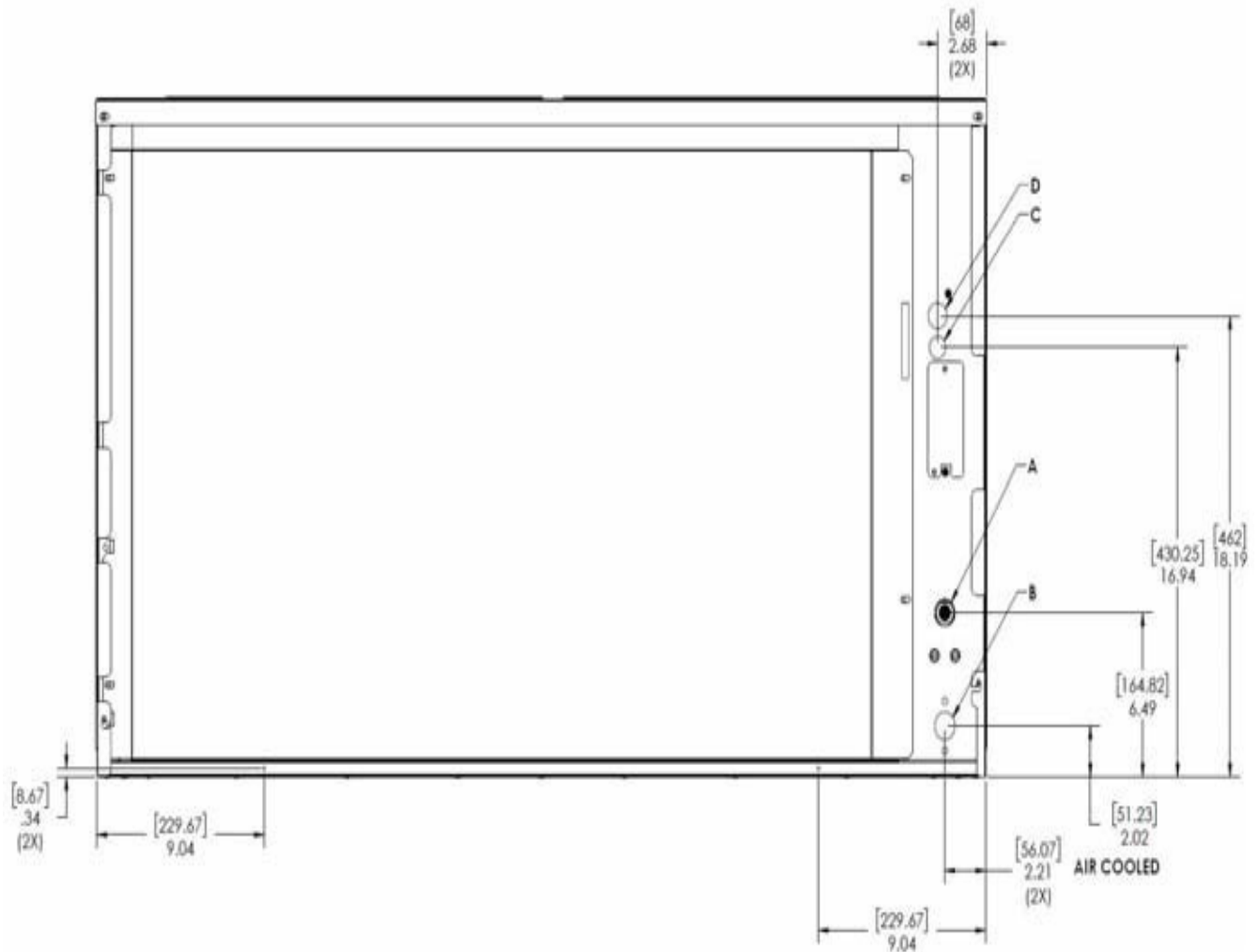

Figure 7.

CNM**48* W/R*6

Water/Remote Cooled

- A. Ice maker potable water in, 3/8" FPT.
- B. Ice maker water out, 3/4" FPT.
- C. Hole for electrical connections, 7/8"
- D. Electrical junction box, 7/8" (remote).
- E. Condenser water in, 3/8" FPT (water only). Discharge line, 1/2" male quick connect coupling for pre-charged line set (remote only).
- F. Condenser water out, 1/2" FPT (water only).
- G. Liquid Line, 3/8" male quick connect coupling for pre-charged line set (remote only).

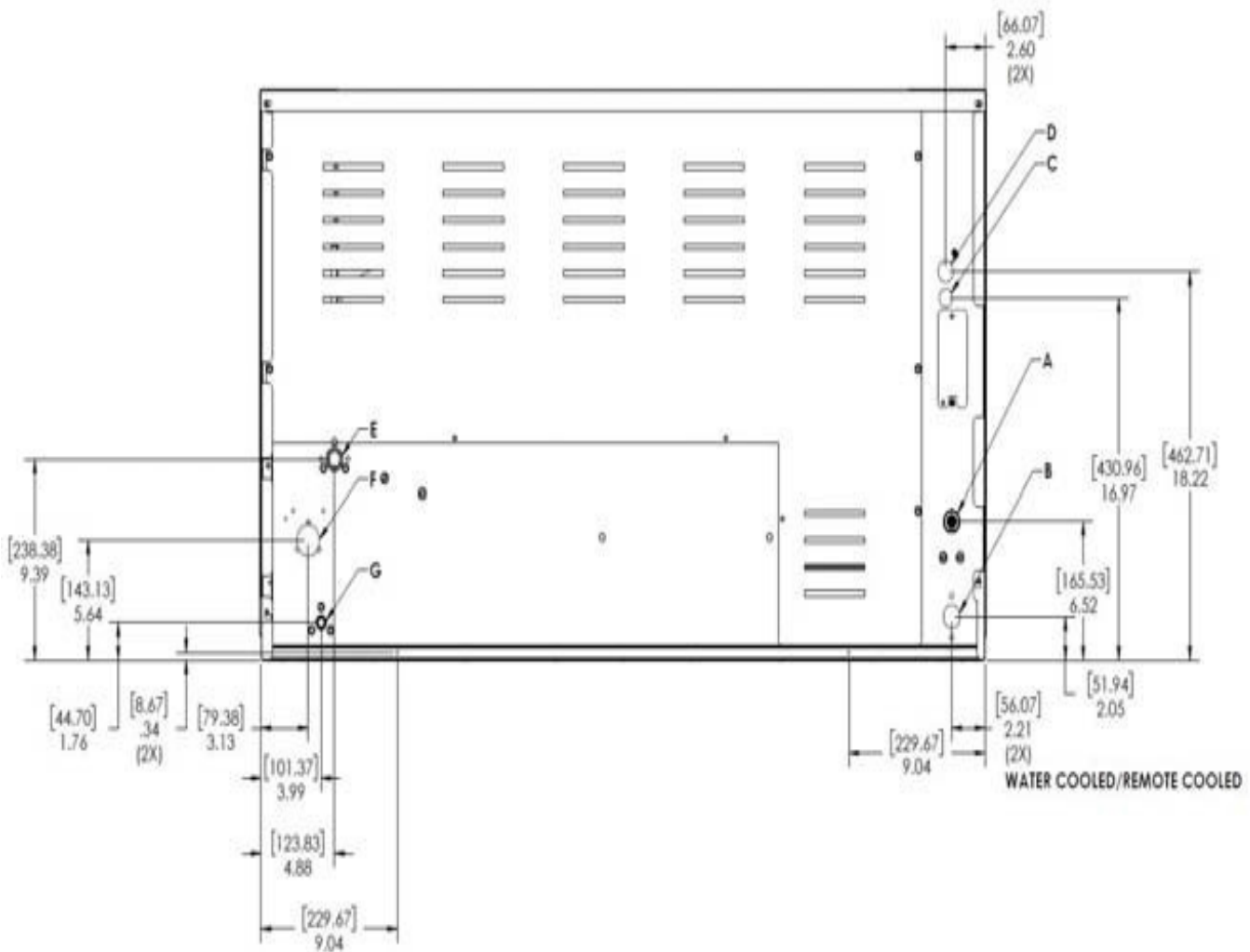

Figure 8.

OPERATION OF THE CNM SERIES CUBER Freeze Cycle

A quick press and release of the ON/OFF button will start operation of the unit. The Water Inlet Valve is energized. Once the HI Water Float is in the open position the Water Inlet is de-energized. The Hot Gas Valve will open for 5 seconds. The Compressor will be energized and 5 seconds later the Hot Gas Valve will close, starting the Pre-chill of the Evaporator. The Fan Motor (if applicable) will start once the Fan Control closes. After the Pre-chill ends, the Water Pump will be energized. Water is now flowing across the Evaporator.

When the water temperature reaches a predetermined factory set point (near freezing), the unit will perform a 20 second shut down of the Water Pump to assist in Anti-Slush of the water in the Sump. At the conclusion of Anti-Slush, the unit will continue in freeze mode until the Low Water Float is satisfied (closes), indicating the formation of a full slab of Ice on the Evaporator and will start the harvest Cycle.

Harvest Cycle

The Fan Motor shuts down as the Hot Gas Valve, Purge Valve and Water Inlet Valve are energized. The Water Inlet Valve will stay energized for additional time after the Purge Valve closes, partially filling the Water Sump.

The unit continues in this mode until the Harvest Assist Assembly helps push the ice slab from the plate and the contacts in the Curtain Switch open as the slab drops into the bin. If the Curtain Switch remains open after the factory preset time in the Harvest Cycle, the unit will shut down on a full bin. If the Curtain opens and closes with the harvest of the ice, the unit will restart the next freeze cycle.

Proper bridge thickness, when measured at the middle of the slab, on the CNM units is approximately 3/16" thick for units less than 400 lbs. and 1/8" for 400 lbs. and above.

CNM CONTROL BOARD

The Board controls the operation of the unit. A series of LED lights show Switch positions and Component operation to assist the technician in understanding and troubleshooting issues that may arise. See Sequence of Operation pg. 12 for operational information.

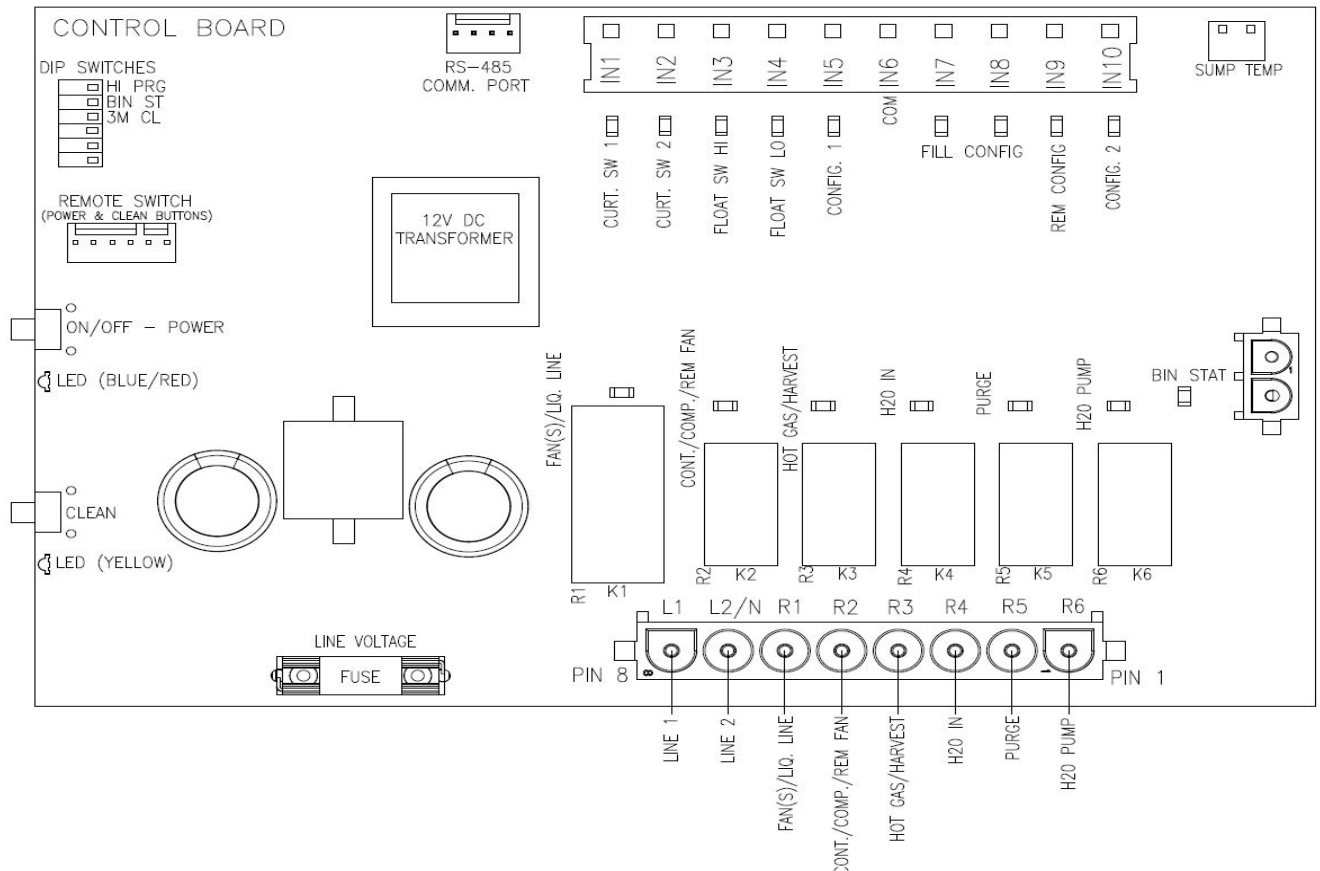

Figure 9.

START-UP PROCEDURE

NOTE: Before starting the machine, make sure the machine is level within 1/8 inch in all directions, the bin or dispenser leg height can be adjusted by rotating the leg foot.

After verifying proper voltage, water supply, drains and breathable air space around the unit, press and quickly release the ON/OFF button behind the unit front panel. The indicator light will change from a solid red to solid blue in color.

Follow the sequence of operation described under "Operation of CNM Series Cuber" in this manual. Check operation of each component through the cycle as explained in this section.

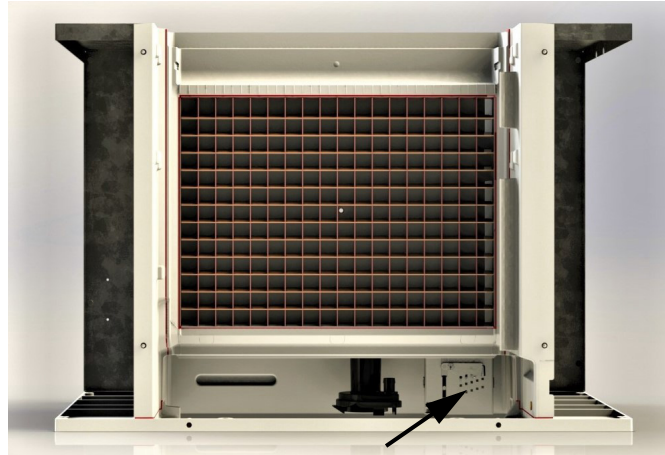

Access to water level Adjustment

Figure 10.

Bridge Thickness Adjustment

Once the unit has gone through a harvest cycle, verify the bridge thickness (3/16" thick for units less than 400 lbs. and 1/8" for 400 lbs. and above) across the middle of the ice slab on the second batch produced. The ice thickness can be changed on the Float Housing by turning the adjustment clockwise to decrease the bridge thickness and counter-clockwise to increase the bridge thickness. You will hear a "click" with each adjustment. It is recommended adjustments be made one or two "clicks" at a time.

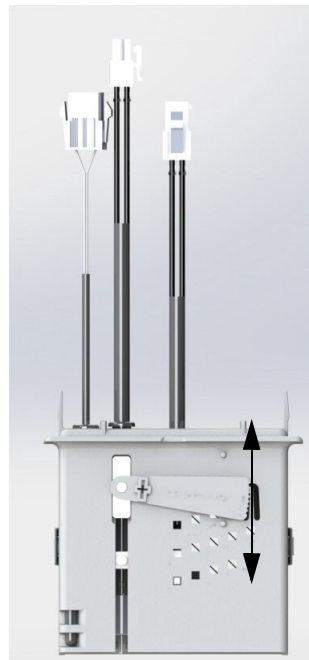

Lowers Float, increases bridge thickness

Raises Float; decreases bridge thickness

Figure 11.

Model	Batch Weight		
	Half Cube	Full Cube	Grande Cube
CNM0330	2.9-3.15	3.25-3.5	-
CNM0530/630	4.9-5.15	5.5-5.8	-
CNM0830/1030	6.9-7.4	7.9-8.3	8.4-8.8
CNM 1448	13.8-14.8	15.8-14.8	-

**WARNING**

Electrical shock and/or injury from moving parts inside this machine can cause serious injury. Disconnect electrical supply to machine prior to performing any adjustments or repairs.

Failure to perform the required maintenance at the frequency specified will void warranty coverage in the event of a related failure.

GENERAL MAINTENANCE PROCEDURE

To insure economical, trouble free operation of your machine; it is recommended that the following maintenance be performed every 6 months.

1. Clean the ice-making section per the instructions below. Cleaning should be performed a minimum of every 6 months. Local water conditions may require that cleaning be performed more often.
2. Check ice bridge thickness. See Figure 11. for proper thickness and adjustment procedure.
3. Check water level in Sump. See Figure 11. for proper water level and adjustment procedure.
4. Clean the condenser (air-cooled machines) to ensure unobstructed air flow.
5. Check for leaks of any kind: water, refrigerant, oil, etc.
6. Check the bin control switch (if applicable) for proper adjustment.
7. Check the Water Regulating Valve (water cooled machine) for proper adjustment by measuring the discharge pressure which should be adjusted to maintain 250 psi (17.01 bar/ 1.723 MPa). Adjust the water regulating valve as required. Water exiting the condenser should be between 100°F (38°C) and 110°F (43°C).
8. Check all electrical connections.
9. Oil the fan motor if the motor has an oil fitting. (Self contained air-cooled models only)
10. Check the water filter (if applicable) and replace if dirty or restricted.
11. Inspect the evaporator water distribution tube to insure even distribution of water across the face of the evaporator.
12. Clean Remote Condenser if applicable.

CLEANING INSTRUCTION FOR CORNELIUS CNM SERIES ICE MACHINES

NOTE: Proper cleaning of an ice machine requires two parts: descaling and sanitizing.

Descaling should be scheduled at a minimum of twice per year but no more than once per month.

Descaling dissolves the mineral deposits on the evaporator and other surfaces. It removes scale, calcium, lime scale and other mineral buildup. Cornelius requires a “nickel-safe” cleaner such as Nu-Calgon Nickel-Safe Ice Machine Cleaner or equivalent diluted per manufacturer’s instructions.

Sanitizing should be performed after each descaling but no more than once per month.

Sanitizing disinfects the machine and removes microbial growth including mold and slime. Cornelius requires a sanitizer such as Nu-Calgon IMS-III or equivalent diluted per manufacturer’s instructions.

Please refer to www.cornelius.com for approved chemical formulations and proper pH balance.



CAUTION

Do not mix cleaner (descaler) and sanitizer together.

NOTE: Electrical power will be ON when performing the following cleaning instructions.

1. Remove all ice from storage means to prevent any contamination of ice in storage.
2. Remove the front panel of the ice machine by loosening the two front panel screws with a Phillips head screwdriver. Lift panel to remove.
3. Press and hold the POWER button for 3 seconds to initiate a harvest cycle (blue light will begin to flash for Manual Harvest mode). This ensures there is no ice on the plate and the water is emptied from the sump.

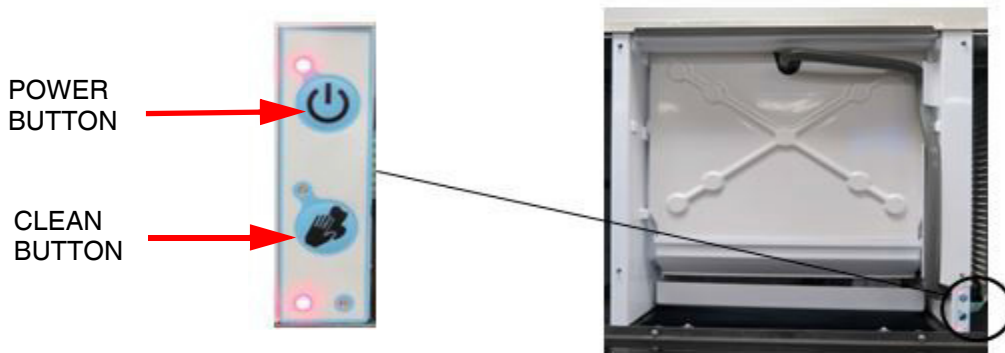

Figure 12.

4. Once the ice machine has completed its harvest cycle, the POWER light will go to solid red (OFF mode).
5. Remove the upper evaporator cover and leave the lower curtain.



Figure 13.

6. Quick press the CLEAN button to start the process. Ice machine will show a solid red and flashing yellow light during the cleaning cycle.
7. The machine will first verify that the sump is empty with the pump ON and the purge valve energized.
8. When the sump is mostly empty, the machine will begin to fill the sump (about 30 seconds to a minute).
9. The pump turns ON when the water fill reaches the proper fill level. Measure the appropriate amount of descaler according to the machine size and sump volume from [chart below](#). Carefully pour the descaler into the sump using the lower curtain to prevent splash. Replace upper evaporator cover.

Model	SUMP SIZE (VOLUME) Gallons (In Liters)	Example: Nu-Calgon Nickel- Safe Ice Machine Cleaner Descaler Con- centration Ratio 5 fl.oz. per 1 gal. of water (39 mL per 1 Liter of water)	Example Nu-Calgon IMS-III Sanitizer Concentration Ratio 1.6 fl. oz. per 1 gal. of water (12.5 mL per 1 Liter of water)
CNM 320/330	.9 (3.4)	Add 4.5 fl. oz. (133 mL)	Add 1.5 fl. oz. (44mL)
CNM 0530/630	1.2 (4.5)	Add 6 fl. oz. (177 mL)	Add 2 fl. oz. (59 mL)
CNM 0830/1030	1.1(4.2)	Add 5.5 fl. oz. (164 mL)	Add 1.8 fl. oz. (53 mL)
CNM 1448	1.8(6.8)	Add 9.0 fl. oz. (265 mL)	Add 2.9 fl. oz. (85 mL)

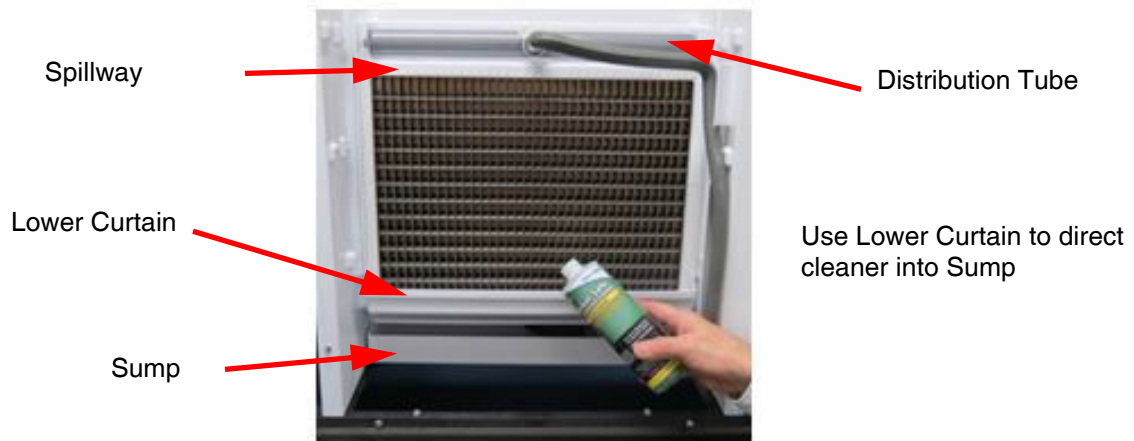

Figure 14.

10. The machine will remain in the WASH cycle for 15 minutes.
11. After WASH time, the machine will PURGE and re-fill with the water pump ON.
12. The machine will RINSE (less than one minute) then repeat PURGE/FILL/RINSE multiple times.
13. The machine will end the cleaning cycle with a mostly empty sump and a solid red and yellow light.
14. Quick press the CLEAN button to return to OFF mode.
15. Remove the upper Evaporator Cover and lower Evaporator Curtain. Using a solution with the proper concentration of cleaner (descaler or sanitizer), wipe down with a clean soft cloth the Evaporator, Water Spillway, Water Distributor, upper Evaporator Cover, lower Evaporator Curtain and all splash surfaces. Verify that all residue and residual minerals have been removed.
16. If a full clean of water components is required, this can be done by referring to the service manual for water system component breakdown. This is recommended to be done by a qualified service agent.
17. Re-assemble all ice machine water system components in reverse order.
18. Sanitizing the ice machine is recommended after descaling. Repeat the process with sanitizer at correct ratio.
19. It is recommended to clean (descale and sanitize) the storage means after cleaning the ice machine.
20. Quick press the POWER button to return the ice machine to the ice making cycle.
21. Replace the front panel and tighten the two panel screws with a Phillips screwdriver.

CABINET CARE

CHEMICALS FOR DESCALING AND SANITIZING

It is important to use solutions that do not harm the ice machine. Never use cleaning or sanitizing solutions that contain Nitric Acid, Sulfuric Acid, Hydrochloric Acid, Carboic Acid, Acetic Acid, diluted Acetic Acid or non- food-grade vinegar (concentration of acetic acid greater than 6% and does not contain enzymes created in processing) or any chlorine-based solution such as bleach, chlorine dioxide or any type of salts such as potassium chloride (potassium salts) or sodium chloride. Check the label or the manufacturer's Material Safety Data Sheet (MSDS) to be sure. These chemicals can attack the surface of the evaporator as well as other metal components causing corrosion and flaking.

Please refer to www.cornelius.com for approved chemical formulations and proper pH balance.

CLEANING STAINLESS STEEL AND ALUMINUM

Commercial grades of stainless steel and aluminum are susceptible to rusting or corrosion if not properly maintained. It is important that you properly care for the stainless steel and aluminum surfaces of your ice machine and bin to avoid the possibility of rust or corrosion.

Use the following recommended guidelines for keeping your machine looking like new:

1. **Clean the stainless steel and aluminum thoroughly once a week.** Clean frequently to avoid build-up of hard, stubborn stains. Hard water stains left to sit can weaken the metals corrosion resistance and lead to rust or corrosion. Use a nonabrasive cloth or sponge, working with, not across, the grain.
2. **Do not use abrasive tools to clean the metal surface.** Do not use steel wool, abrasive sponge pads, wire brushes or scrapers to clean the metal.
3. **Do not use cleaners that use chlorine or chlorides.** Do not use chlorine bleach products to clean the metal surfaces. Chlorides break down the metals protective layer.
4. **Rinse with clean water.** If chlorinated cleansers are used, you must thoroughly rinse the surface with clean water and wipe dry immediately.
5. **Use the right cleaning agent.** The table below lists the recommended cleaning agents for common metal cleaning problems.

Cleaning Activity	Cleaning Agent	Method of Application
Routine Cleaning	Mild dish soap, ammonia, glass cleaner, or mild detergent with water. Household kitchen cleaning chemicals approved for metal surfaces.	Apply with clean cloth or sponge. Rinse with clean water and wipe dry.
Removing grease or fatty acids	Oven cleaners	Apply generously; allow to stand for 15-20 minutes. Rinse with clean water. Repeat as required.
Removing hard water spots and scale	Vinegar	Swab or wipe with clean cloth. Rinse with water and wipe dry.

WINTERIZING PROCEDURES

IMPORTANT: Whenever the ice machine is taken out of operation during the winter months, the procedure below must be performed. Failure to do so may cause serious damage and will void all warranties.

1. Turn off water to machine.
2. Make sure all ice is off of the evaporator(s). If ice is being made, initiate harvest by pressing the Power Button for approximately 3 seconds. The unit will shut off automatically following the harvest.
3. Disconnect the tubing between the water pump discharge and water distribution tube and drain any water.
4. . On water cooled machines, hold the water regulating valve open by prying upward on the water valve spring with a screwdriver while using compressed air to blow all the water out of the con- denser.

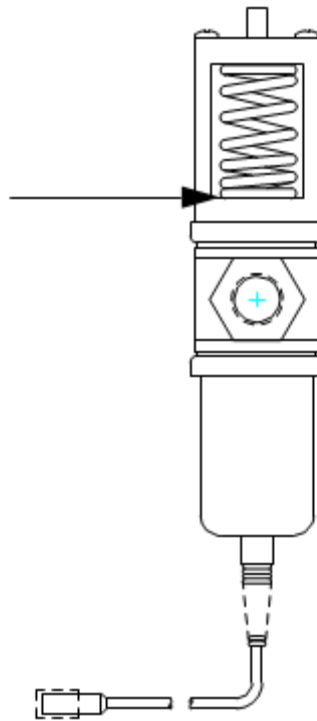

Figure 15.

5. Remove all of the ice in the storage bin and discard.

CNM SERIES ICE MAKER FREQUENTLY ASKED QUESTIONS

1. What is the factory float setting on a replacement float assembly?

Replacement float housings come with the high float set in the #1 position. The high float needs to be inserted, per the provided instruction, into the correct float setting of the machine receiving the replacement float assembly.

2. What is the factory high float setting on a new machine?

The CNM series float settings by nominal capacity are listed below

<u>Nominal Capacity</u>	<u>Half</u>	<u>Full</u>	<u>Grande</u>
300lbs	#2	#3	-
400 through 600lbs	#8	#9	-
800 through 1100lbs	#3	#4	#5
1400lbs	#4	#5	-

3. How do I adjust the ice bridge thickness?

The CNM series' bridge thickness may be adjusted by moving both a high and a low float.

4. Why is my new machine occasionally producing extra thick batches of ice?

When occasional thick batches of ice occur, the bridge thickness may be set too low. When a batch of ice does not have a thick enough bridge, it can split and only have half a batch fall into the ice bin. The curtain is opened and closed by this half batch, causing the machine to go back into freeze mode. The remaining ice from the previous cycle is added to the new batch of ice being formed, causing it to be especially thick.

5. Why causes the machine to produce cloudy/hazy ice?

Cloudy ice is the result of impurities getting trapped as the ice forms. These impurities include dissolved mineral, chemicals, and air. These are a few items to consider if your machine is producing cloudy ice:

- The low float is used for fine bridge thickness adjustment via an adjustment arm. Turning this arm counter-clockwise lowers the float and increases bridge thickness. Rotating the arm clockwise raises the low float, decreasing bridge thickness.
- A greater change to the bridge thickness than the low float adjustment can provide is possible by moving high float up or down one position. Moving the high float up increases bridge thickness, while moving this float down, decreases the bridge thickness.
- Verify the purge valve is operating correctly, and that the drain line inside the machine is not kinked or blocked in any way.
- Use a vented drain line from the machine to the floor drain.
- Change the machine to use the "High Purge" setting in areas with water that has an elevated concentration of dissolved minerals.
- Avoid using water that has had phosphate added or is from a water softener.

6. What do I do if I can't get the curtain to stay on the machine?

For curtain issues, please contact Cornelius. CNM machines built before January of 2018 are eligible for an enhanced curtain design that ensures it will stay in place under all operating conditions. Machines built after 2017 have a newer evaporator assembly design that improves the ice maker's curtain retention, and is incompatible with the enhanced curtain.

7. The lights on my machine are blinking, what does it mean?

The CNM series of ice makers utilizes 3 LED's to provide information on the status of the machine at a glance.

More information is available on the inside of the left panel of the machine, but a basic description is as follows:

- **Solid or Blinking Blue:** A blue light indicates the machine is operating normally. It could be making ice, waiting for the ice bin to empty, or, in the case of a blinking blue light, performing a regular extended harvest.

- **Solid Red:** The machine is off.

- **Blinking Red:** If the machine is blinking red slowly (once a second) a non-critical error has occurred. The machine will still make ice, but at a reduced level of functionality. A fast red blink (twice a second) indicates a critical issue has arisen and needs to be diagnosed before the machine will continue making ice.

Blinking Yellow: The yellow/amber LED begins to blink when it has been 6 months (3 months if the 3 month setting has been enabled on the control board) since the last clean cycle was run. This clean LED will be reset once a full clean cycle has been completed.

SEQUENCE OF OPERATIONS

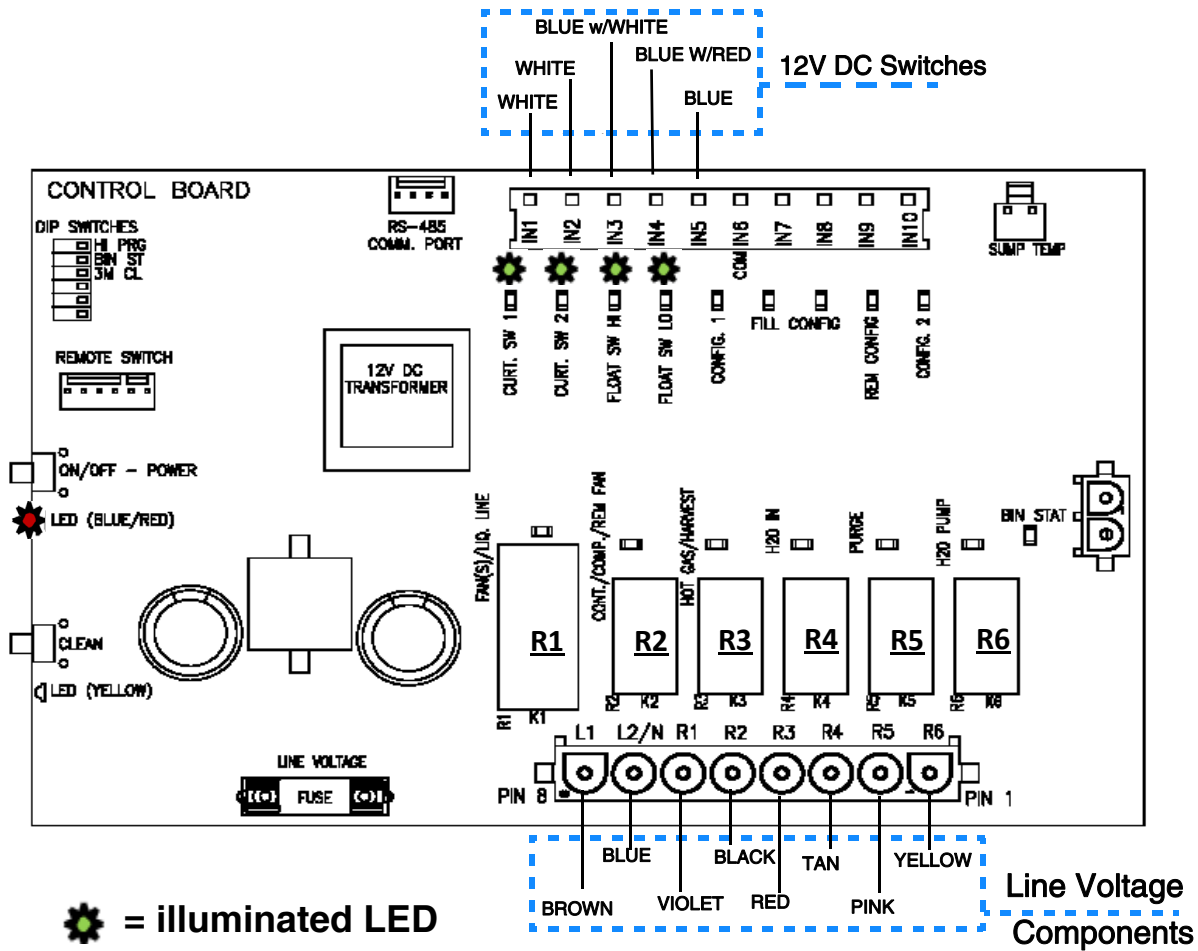

Control Board - Off Status

When power is initially applied to the unit, the LED's on both the Push Pad and the Board POWER Button will flash in sequence BLUE, then RED, then the WASH Button will flash YELLOW, followed by the POWER Button LED will turn a solid RED, indicating the unit is in the OFF status as shown above.

The LED's for the Curtain Switches (1 & 2), High Float Switch and Low Float Switch will be illuminated indicating closed circuits. Should the Curtains or Bin Thermostat (if added) be open, the unit will not start a Freeze Cycle.

From an OFF status, the unit can start a CLEAN cycle, a FREEZE cycle or be put in the DIAGNOSTIC mode.

For Cleaning Instructions, see page 19.

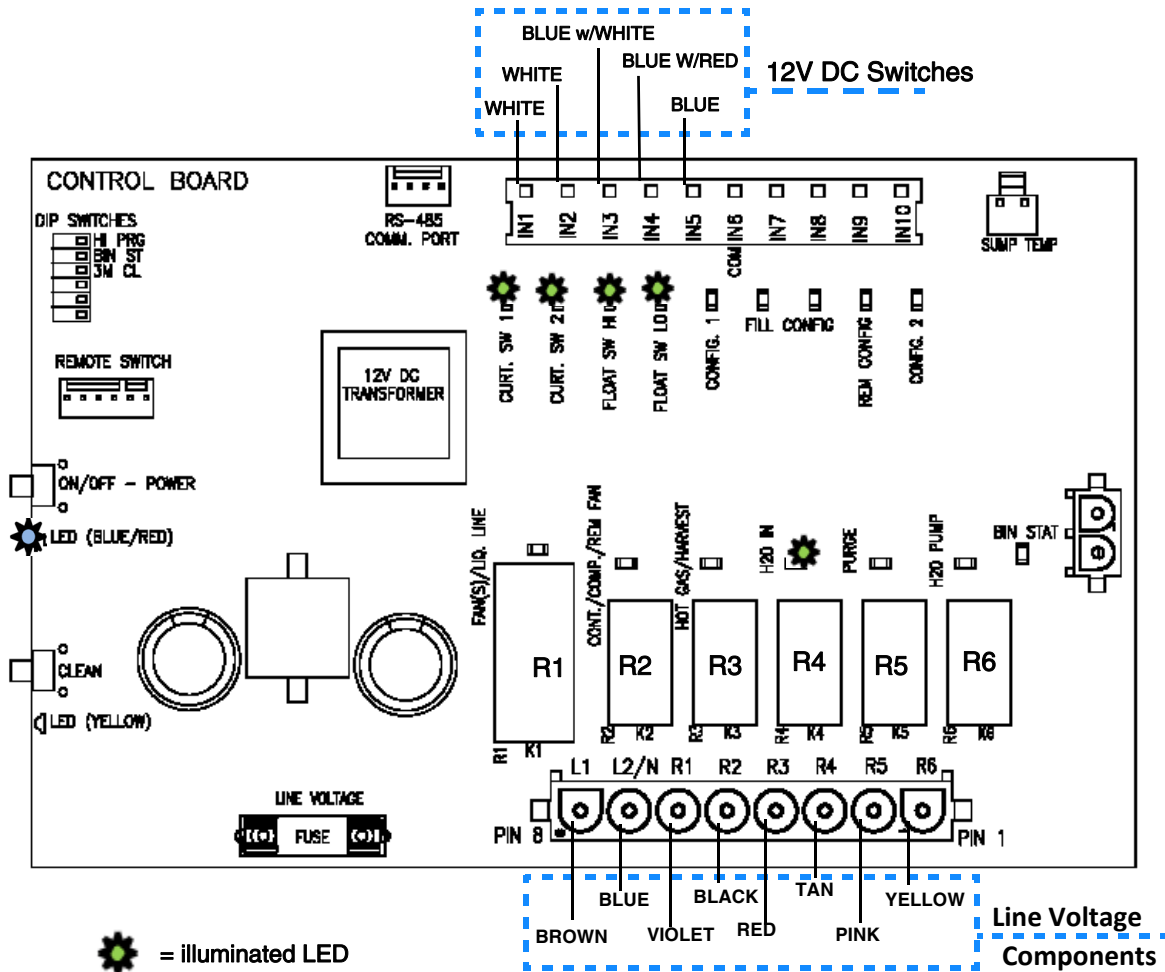

Figure 16.

CONTROL BOARD - FREEZE CYCLE

A quick press of the POWER button on the Push Pad or Board will start the Freeze cycle. The Water Inlet Valve will be energized (R4 LED on Board illuminated) and water will begin flowing into the Sump. As the water rises, the contacts in the Low Water Float will open (Switch LED off). The Water Inlet Valve will remain energized until the High Water Float contacts open (Switch LED off). The Water inlet Valve will be de-energized (R4 LED on Board off).

NOTE: Minimum Freeze Cycle - 5 minutes (from Compressor Start.)

Maximum Freeze Cycle - 1 hour.

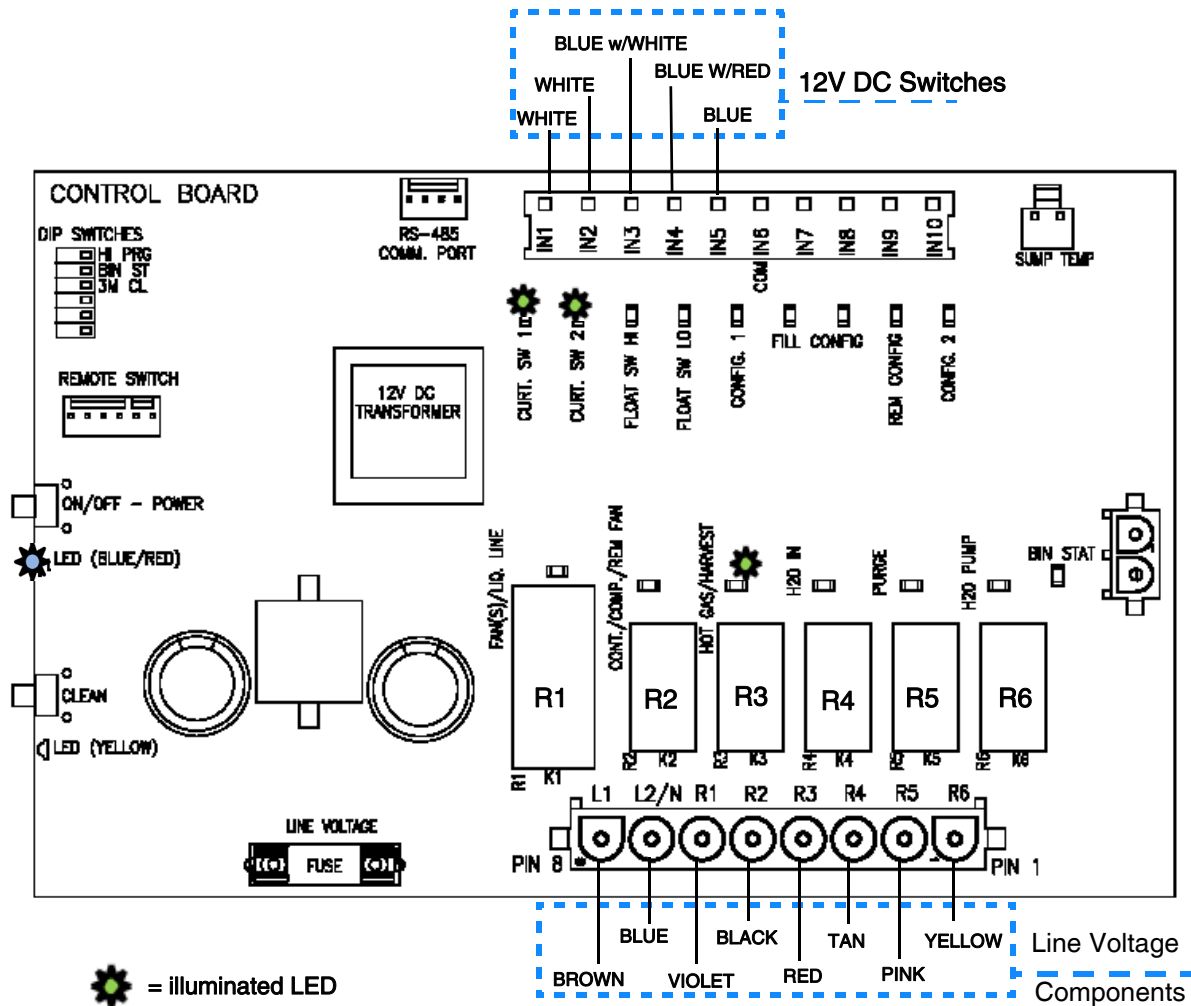

Figure 17.

CONTROL BOARD - COMPRESSOR START

The Hot Gas Valve will be energized (R3 on Board illuminated) for 5 seconds and the system pressures will start to equalize.

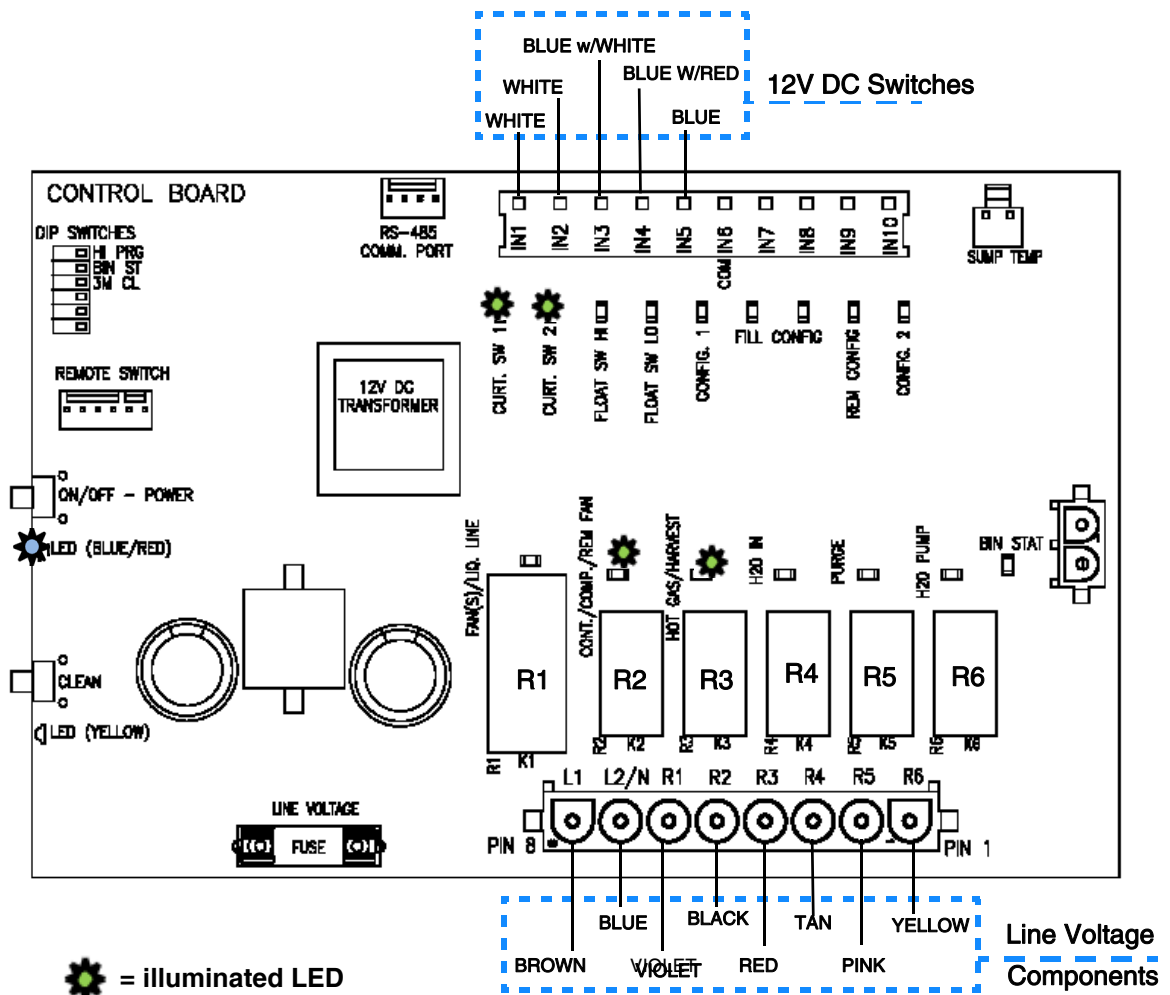

Figure 18.

CONTROL BOARD - COMPRESSOR START

The Compressor will be energized (R2 on Board illuminated) and the Hot Gas Valve will remain open for 5 more seconds and then de-energize (R3 on Board off).

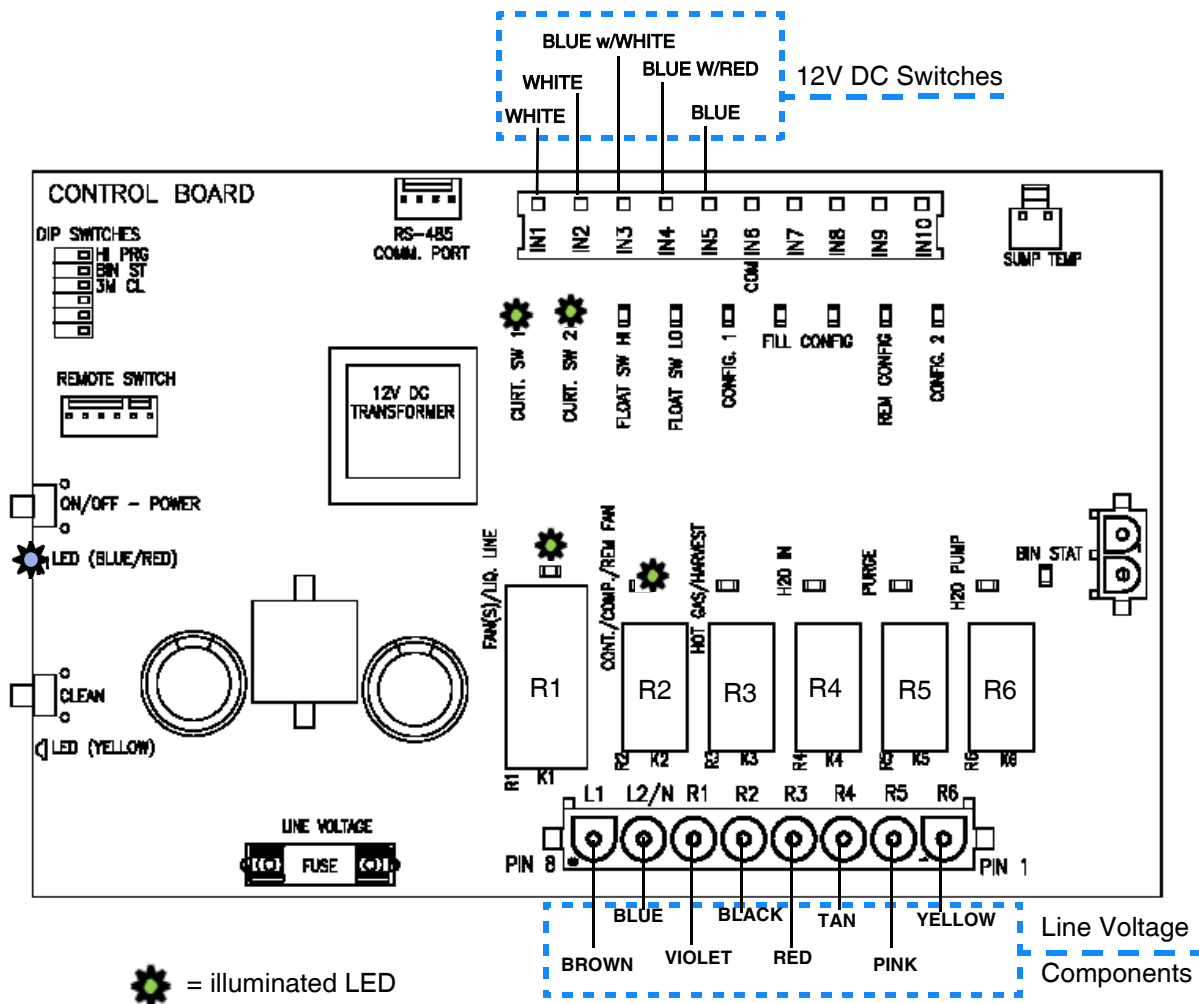

Figure 19.

CONTROL BOARD - PRE-CHILL

The Compressor and Fan(s)/Liquid Line Solenoid (R1 and R2 LED's on Board illuminated) are energized and unit is now in a Pre-Chill for 30 seconds bringing the Evaporator temperature down. Both Curtain Switch LED's are on showing closed curtain(s). Even though (R1) is energized the Fan Motor will only come on once the Fan Cycle Switch closes at 250 psi of head pressure.

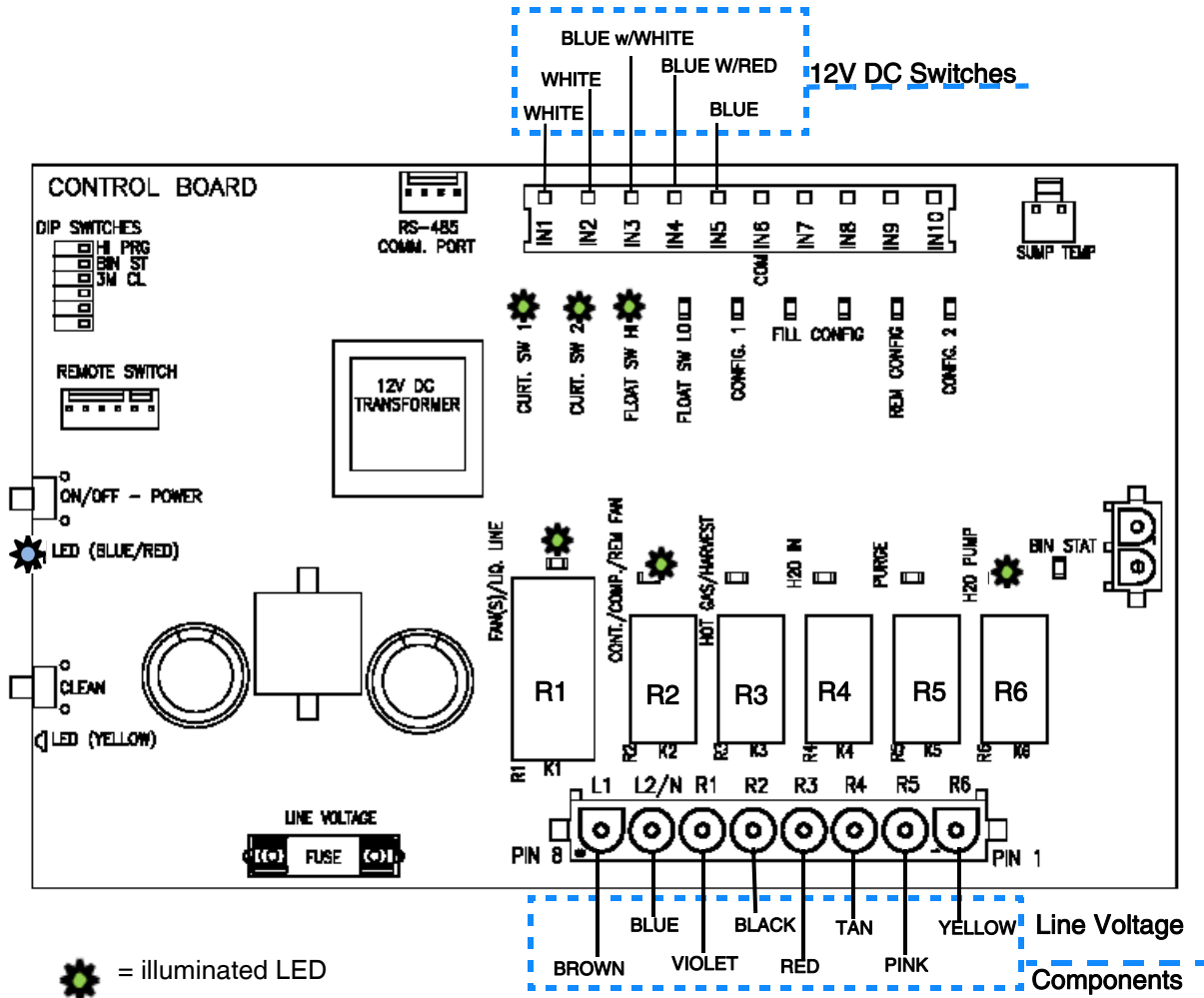

Figure 20.

CONTROL BOARD - FREEZE

The Water Pump is energized (R6 LED on Board illuminated) and water is pushed through the Water Pump Tube and flows over the Evaporator. The High Float Switch contacts close as the water level in the Sump drops (High Float Switch LED on Board illuminates).

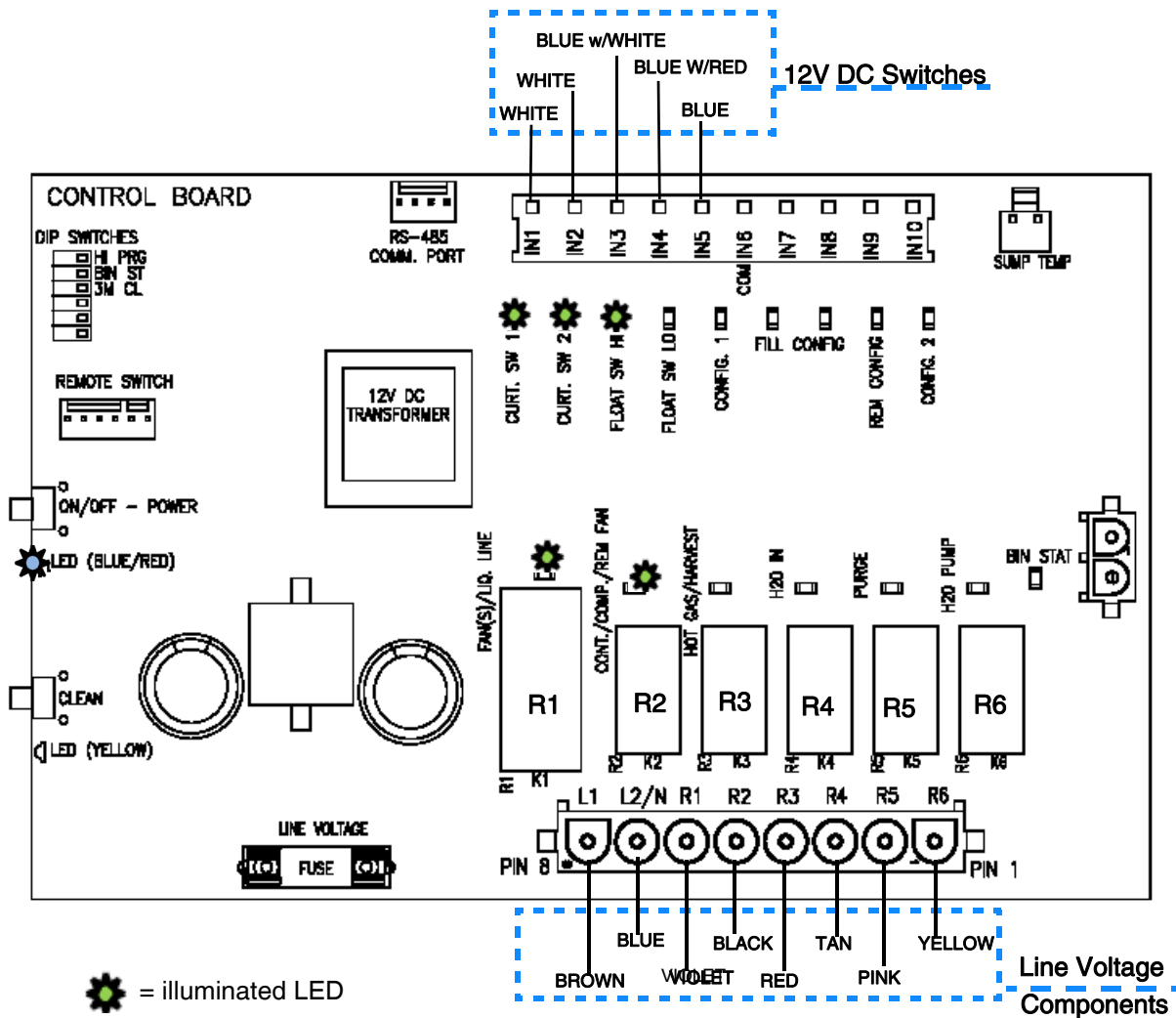

Figure 21.

CONTROL BOARD - ANTI-SLUSH

During the first 3 cycles as the water temperature reaches 36 degrees F. the Water Pump will shut off for 20 seconds to reduce the possibility of slush developing in the Sump. After the first 3 cycles, Anti-Slush will only occur if the Sump water temperature reaches 28 degrees F.

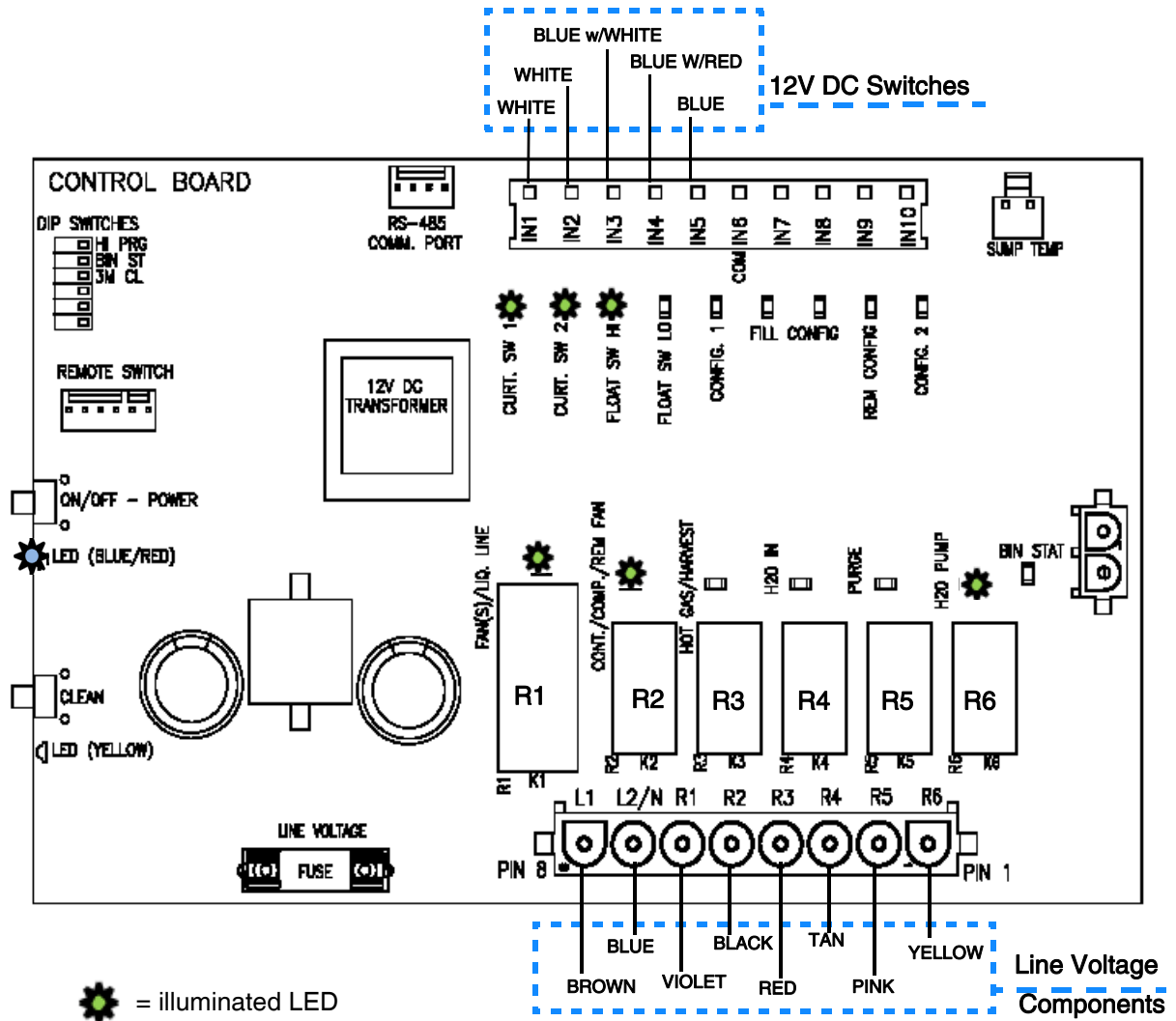

Figure 22.

CONTROL BOARD - WATER PUMP ON

At the end of Anti-Slush the Water Pump (R6) will be re-energized and water starts flowing over the Evaporator again. The unit will stay in this mode until the Low Float Switch closes on water level drop, indicating the unit is ready to harvest.

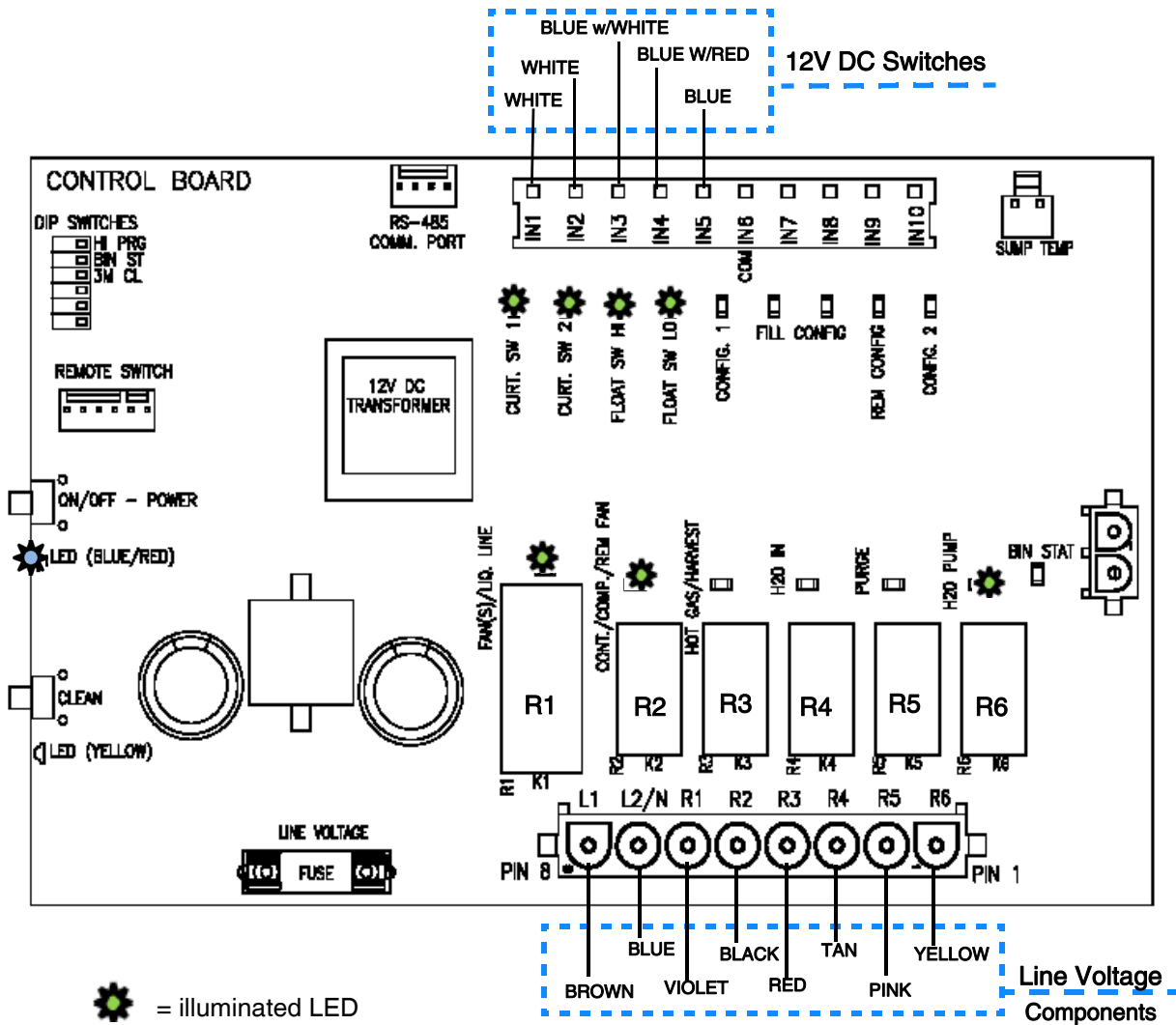

Figure 23.

CONTROL BOARD - INITIATING HARVEST

When the water level in the SUMP drops to close the contacts of the Low Float Switch (LED on Board illuminates) after a 5 second de-bounce of the switch will signal the start of the Harvest Cycle.

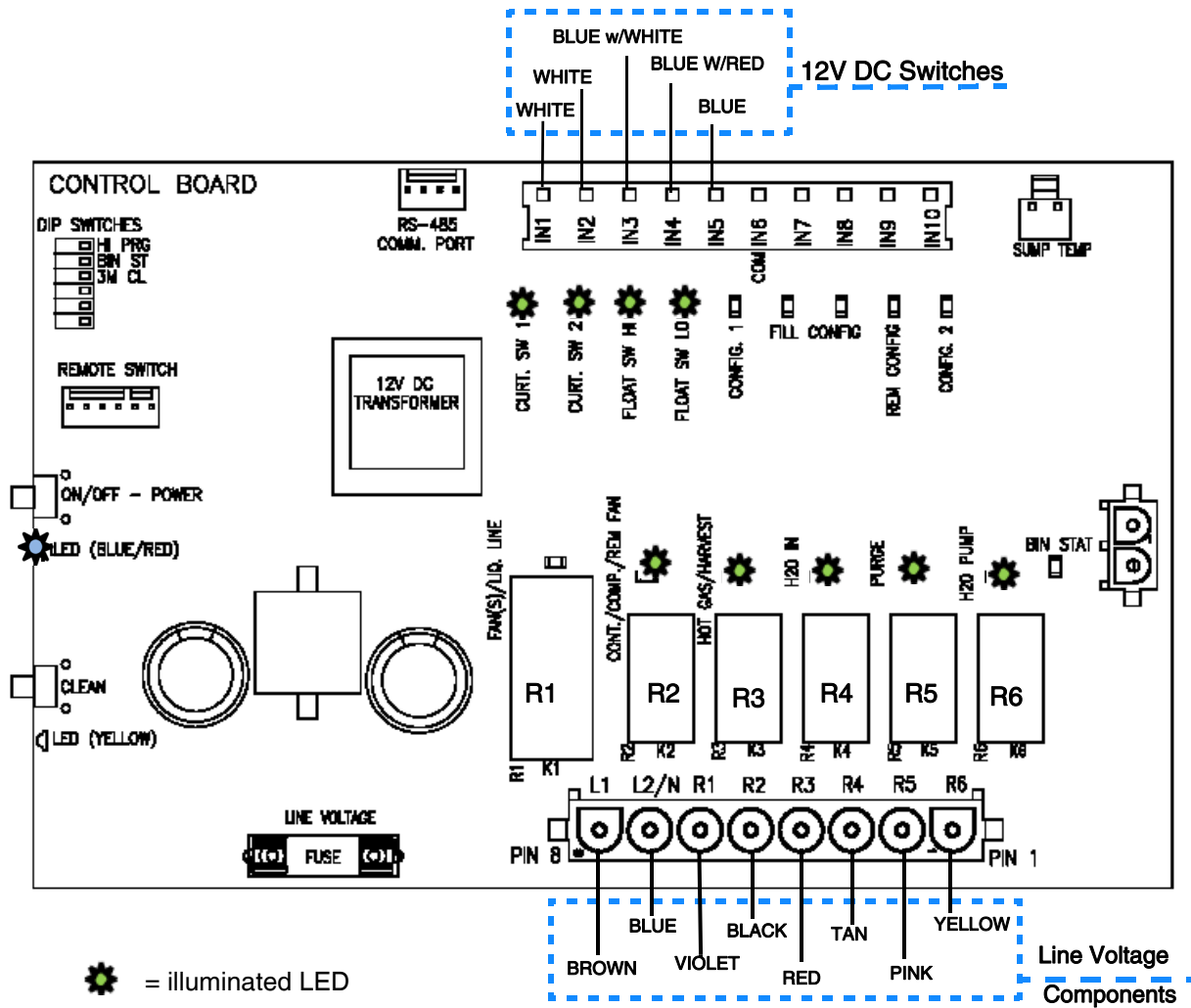

Figure 24.

CONTROL BOARD - HARVEST

After the contacts of the Low Float Switch close, the Harvest Cycle starts by energizing the Hot Gas Valve, Harvest Assist, Purge Valve AND Water Inlet Valve (R2, R3, R4, R5 and R6 are illuminated on Air and Water Cooled units, ALL Relays are energized on Remotes.) The Purge Valve will close after 7 seconds.

NOTE: Minimum Harvest time is 20 seconds. Maximum Harvest time is 5.5 minutes.

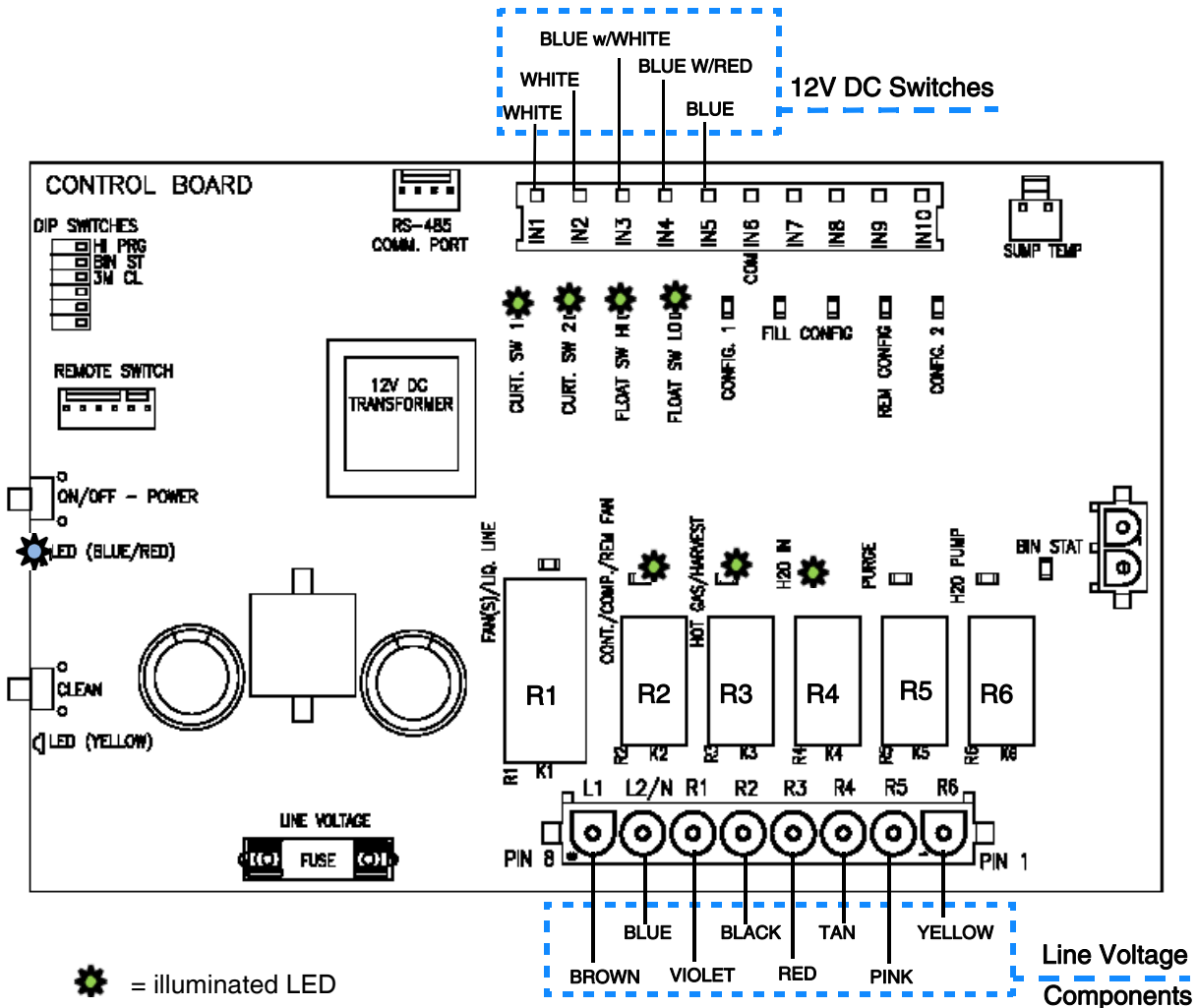

Figure 25.

CONTROL BOARD - HARVEST

After the Purge Valve and Water Pump de-energize, the Water Inlet Valve will remain open for 20 seconds, partially filling the SUMP in preparation for the next Freeze Cycle (R2, R3, and R4, are illuminated on Air and Water Cooled units, R1 is also energized on Remotes.) The Low Float Switch will go off as the water level rises.

The Hot Gas Valve and Harvest Assist will remain energized for the remainder of the Harvest Cycle.

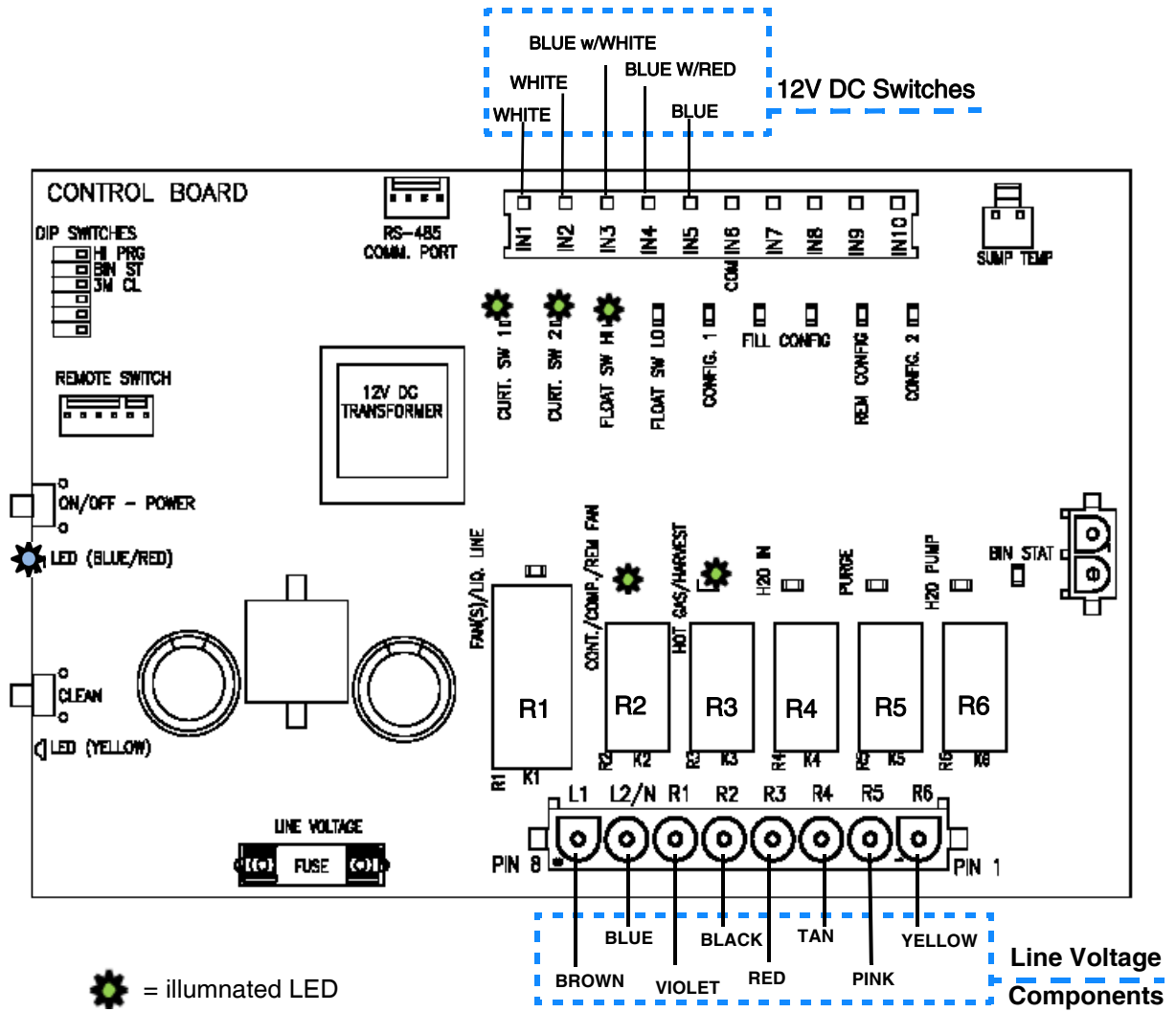

Figure 26.

CONTROL BOARD - HARVEST

After the Water Inlet Valve closes following the 20 second time out, the Hot Gas Valve and Harvest Assist will remain energized until the ice slab is harvested from the Evaporator. At this point the unit is reading the Curtain Switch (s) and/or Bin Thermostat (if added).

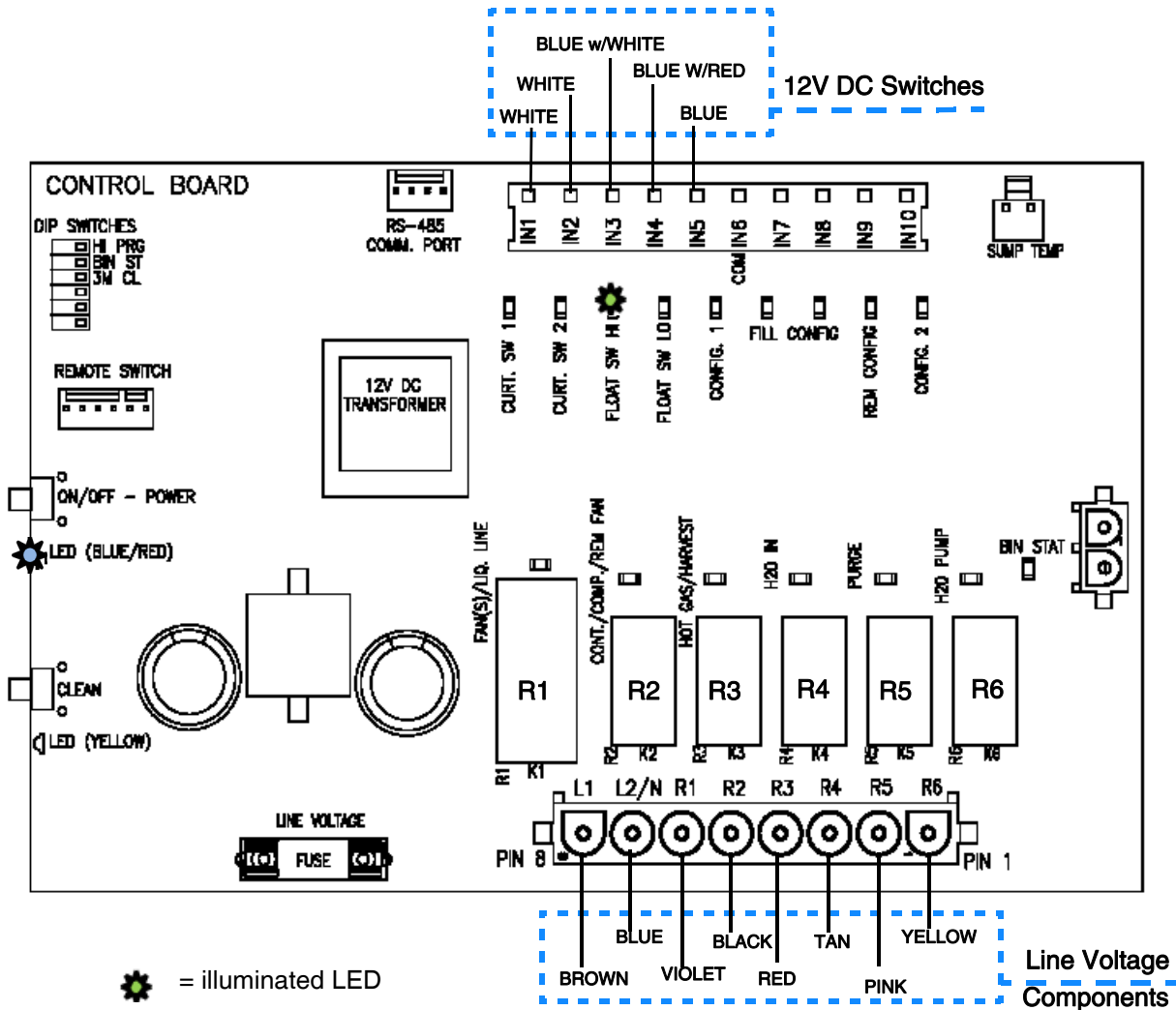

Figure 27.

CONTROL BOARD - BIN FULL

As the ice slab falls from the Evaporator, the Curtain(s) is pushed out, contacts of the Magnetic Curtain Switch(s) open as the ice slab falls. If the Curtain(s) remains open for 30 seconds, the unit will shut down on a full bin. All RELAY LED's (R1 - R6) will go off. If the storage is not full, the unit will restart the next cycle. See pg. 30.

Anytime the unit is turned off or cycles off on a full bin due to a Curtain Switch being open for 30 seconds and/or an added Bin Thermostat remaining open for 90 seconds, the unit will not restart for 3 minutes, preventing a Compressor short cycle.

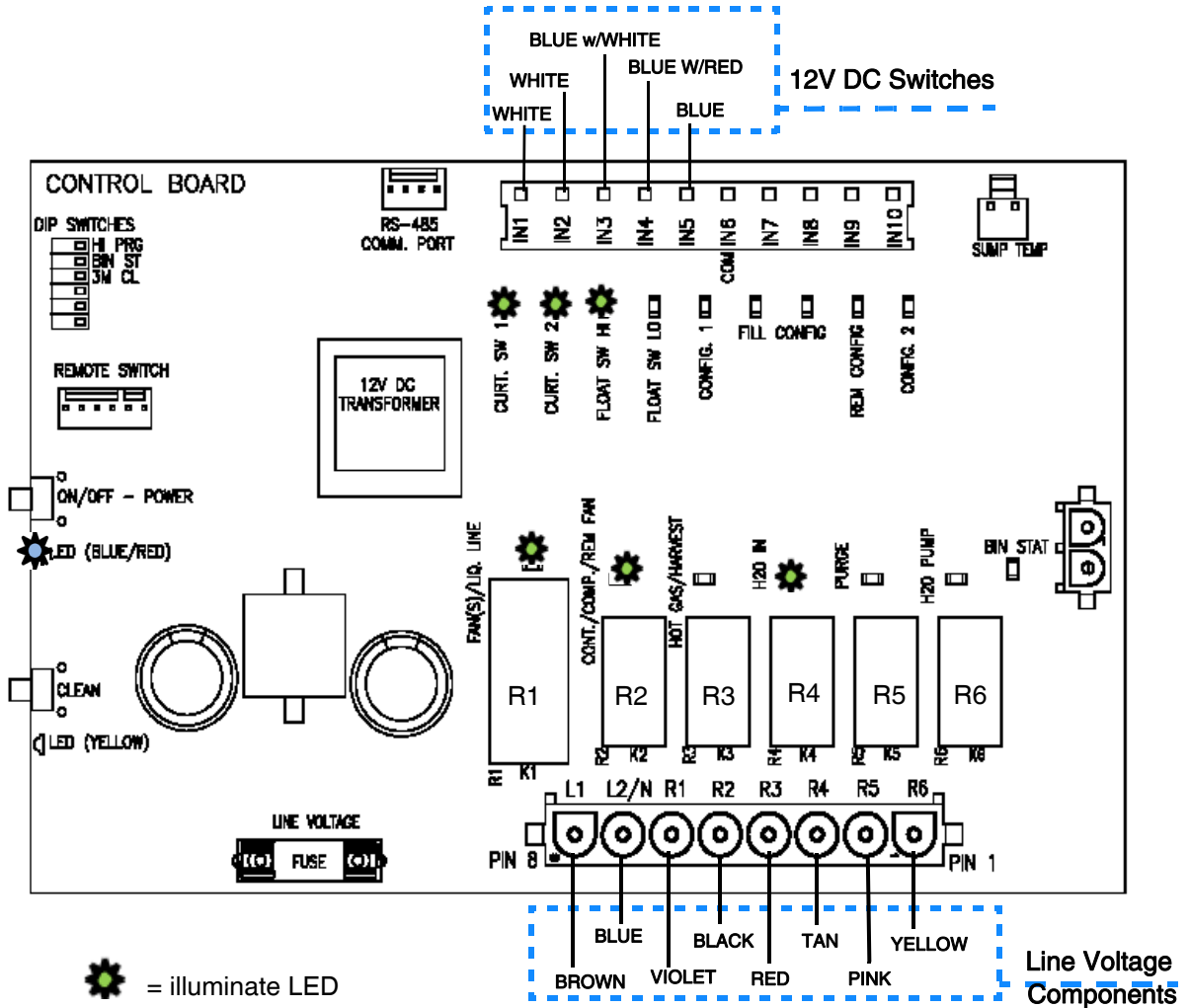

Figure 28.

CONTROL BOARD - RETURN TO FREEZE

As the ice slab falls from the Evaporator, the Curtain(s) is pushed out and the contacts of the Curtain Switch(s) open and close, terminating the Harvest Cycle. With a closed Curtain and Bin Thermostat (if added), the unit will restart the Freeze Cycle. The Compressor (R2) and Fan(s) (R1) will continue operation as the Water Inlet Valve (R4) is energized to fill the Sump until the High Water Float opens.

CONTROL BOARD FEATURES

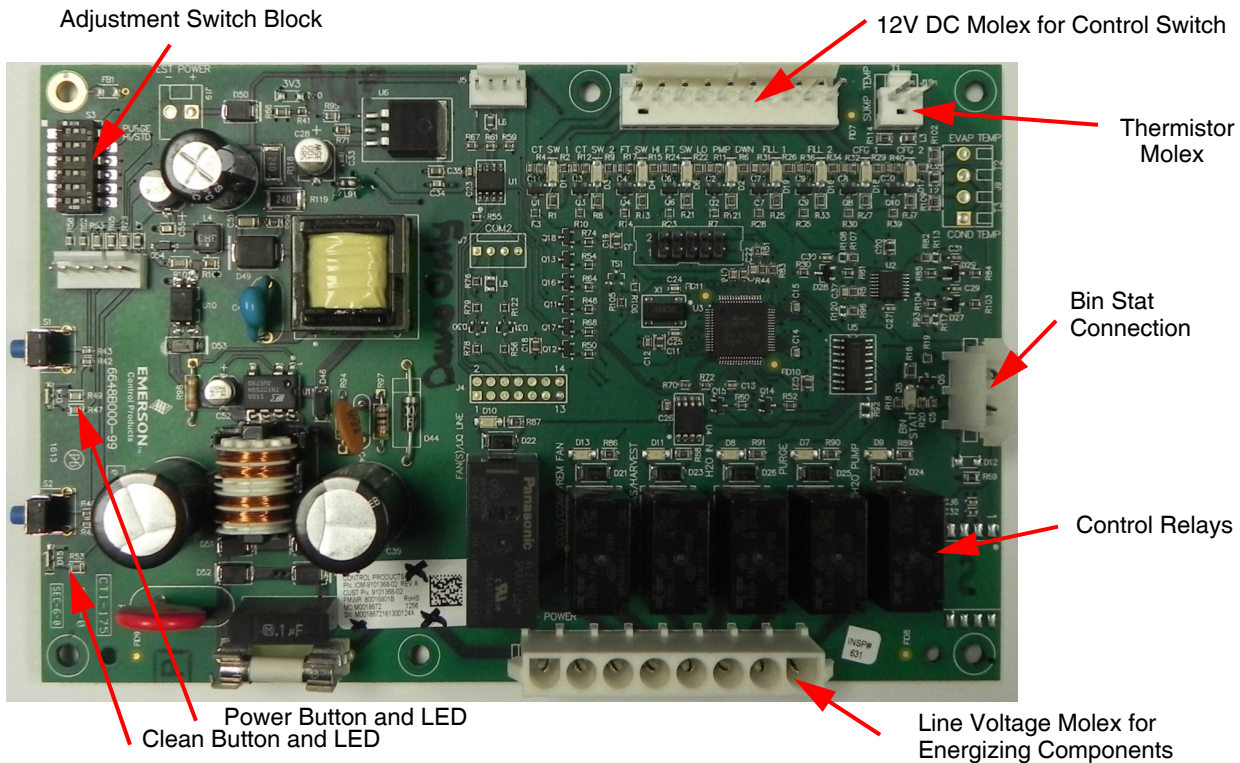

Figure 29.

Adjustment Switch Block

Three adjustments can be made on the block. Extended Purge, Bin Thermostat Kit add-on and Cleaning Needed Reminder.

Standard Purge time during a Defrost Cycle is set at 7 seconds. To add an additional 5 seconds to the purge time, move Switch 1 to the right, to the ON position.

Should the unit be installed on top of a dispenser, a Bin Thermostat Kit is required. Following the instruction that come with the kit, Switch 2 needs to be moved to the ON position to tell the program to read the Bin Thermostat. The LED beside the Bin Stat Connection will then illuminate. The Switch 3 on the block is for the Cleaning Needed Reminder. When in the OFF position, the default setting for the reminder is 6 months. When Switch 3 is moved to the ON position, the Reminder is set for every 3 months. This is recommended should the unit be installed in a hard water location to help with production levels.

12V DC Molex for Control Switches

This Molex connects the Magnetic Curtain Switch(es), High Float Switch, Low Float Switch and Remote Configuration Switch to the Board. The LED's associated to each switch will illuminate when the contacts for each are closed. The Remote Configuration LED will be illuminated when the Smart Harness reads the unit has a Remote Condenser. The Configuration 1 and both Fill Configuration LED's are not used as of the printing of this manual.

Thermistor Molex

The Thermistor is used to gauge the water temperature in the Sump and is used to activate the Anti-Slush Cycle. When the water temperature reaches 36 degrees F during the first 3 cycles following a full bin situation, being restarted after a loss of power or turned off, the Water Pump will be turned off for 20 seconds to help prevent slushing of the water in the Sump. An Anti-Slush will also be performed any time the water temperature reaches 28 degrees F.

Control Relays

The six Control Relays send voltage out to the individual components during the operation of the unit. Relay 1 energizes the Fan(s) on self contained air cooled units or the Liquid Line Solenoid on Remotes. Relay 2 energizes the Compressor through the Contactor (and Fan Motor on Remotes). Relay 3 energizes the Hot Gas Valve and Harvest Assist Assembly during the Harvest Cycle. Relay 4 energizes Water Inlet Valve. Relay 5 energizes the Purge Valve. Relay 6 energizes the Water Pump.

Line Voltage Molex

The Line Voltage Molex connects for each component to the Board. See the wiring diagram for each unit to see the wiring colors associated with each component.

Power and Clean Buttons

These buttons are functional duplicates of the buttons on the Push Pad mounted to the front frame of the unit. See also "Button Function" chart in this manual for operation.

Power and Clean LED Flash Description

SOLID - On Constantly

SLOW - Flashes once every second

QUICK - Flashes once every half second

DOUBLE SLOW - Flashes twice then 1 second delay

DELAYED - flashes once every 3 seconds

Error Codes

Error 1 - POWER LED QUICK FLASH RED - Unit has experienced a MAX Freeze (1 hr), MAX Harvest (5.5 minutes) or BOTH.

Error 2 - POWER LED SLOW FLASH IN OFF STATE ONLY - Thermistor Failure.

Error 3 - POWER LED RED AND CLEAN LED YELLOW QUICK FLASH - Unit has experienced a MAX Fill (5 min) or MAX Purge (2 min).

Minimum / Maximum Times

Freeze - 5 Minute Minimum / 1 Hour Maximum

Standard Harvest - 20 Second Minimum / 5.5 Minute Maximum

Water Fill - No Minimum / 5 Minute Maximum

Purge - 7 Second Minimum / 2 Minute Maximum



BOARD LED SEQUENCE DURING OPERATION - INITIAL FREEZE CYCLE AT START-UP

<u>INITIAL FREEZE AT START-UP</u>		<u>OFF</u>	<u>FREEZE</u>						
<u>COMPONENTS</u>		<u>RELAY #</u>	<u>FILL VERIFICATION</u>	<u>PRESSURE EQUALIZE</u>	<u>PRESS. EQ. W/ COMPR.</u>	<u>PUMP DELAY</u>	<u>FREEZE</u>	<u>ANTI-SLUSH</u>	<u>FREEZE</u>
FAN(S) W/FAN CYCLE (A & W)	R1	-	-	-	ON	ON	ON	ON	ON
LIQ. LINE VALVE (REMOTE)	R1	-	-	-	ON	ON	ON	ON	ON
CONTACTOR/COMPRESSOR/REM. COND. FAN	R2	-	-	-	ON	ON	ON	ON	ON
WATER PUMP	R3	-	-	-	-	-	ON	-	ON
HOT GAS VALVE(S)	R4	-	-	ON	ON	-	-	-	-
HARVEST ASSIST(S)		-	-	-	-	-	-	-	-
WATER INLET VALVE	R5	-	ON	-	-	-	-	-	-
PURGE VALVE	R6	-	-	-	-	-	-	-	-
NOTES:		VERIFY CONFIG 1 (PUMP DOWN FOR REM ONLY)	HIFLOAT SW. OPEN	COMPRESSOR START UP - APPROX 5 SEC.	COMP. START UP - HGV CLOSES AFTER APPROX 5 SEC.	PRE-CHILL THE EVAP PLATE - APPROX 30 SEC.	FREEZE	AT SUMP TEMP 36F, TURN OFF PUMP - APPROX 20 SEC.	CONTINUE FREEZE TO LOW FLOAT SW. CLOSE

Figure 30.

BOARD LED SEQUENCE DURING OPERATION - INITIAL HARVEST CYCLE AT START-UP

INITIAL CYCLE AT START-UP (CONTINUED)		HARVEST					
		POWER LED SOLID BLUE					
COMPONENTS	RELAY #	PURGE ON ENTERING HARVEST	TIMED FILL	WAIT FOR HARVEST	CURT. SW. OPENS		
FAN(S) W/FAN CYCLE (A & W)	R1	-	-	-	-		
LIQ. LINE VALVE (REMOTE)	R1	ON	ON	ON	ON		
CONTACTOR/ COMPRESSOR/ REM. COND. FAN	R2	ON	ON	ON	ON		
WATER PUMP	R3	ON	-	-	-		
HOT GAS VALVE(S)	R4	ON	ON	ON	ON		
HARVEST ASSIST(S)		ON	ON	ON	ON		
WATER INLET VALVE	R5	ON	ON	-	-		
PURGE VALVE	R6	ON	-	-	-		
NOTES:		TIMED SUMP FLUSH AND PURGE - APPROX 7 SEC.	INITIAL TIMED FILL 20 SECS. OR TO HIGH FLOAT SW. OPEN	WAITING FOR CURTAIN SW. OR BIN STAT	ICE RELEASED - HARVEST TERMINATED		

Figure 31.



BOARD LED SEQUENCE DURING OPERATION - TRANSITION FROM HARVEST TO FREEZE

TRANSITION HARVEST -> FREEZE		CONTROLLER STATES												
		HARVEST					FREEZE							
		POWER LED SOLID BLUE												
COMPONENTS	RELAY #	HOT GAS-HAA/ PURGE/ WATER INLET	HOT GAS- HAA/TIMED FILL	HOT GAS/HAA	CURTAIN SW (1 & 2) OPEN	CURTAIN SW (1 & 2) CLOSE	PRE-CHILL AND FILL	FREEZE						
FAN(S) W/FAN CYCLE (A & W)	R1	-	-	-	-	-	ON	ON	ON	ON	ON	ON	ON	ON
LIQ. LINE VALVE (REMOTE)	R1	ON	ON	ON	ON	ON	ON	ON	ON	ON	ON	ON	ON	ON
CONTACTOR/ COMPRESSOR/ REM. COND. FAN	R2	ON	ON	ON	ON	ON	ON	ON	ON	ON	ON	ON	ON	ON
WATER PUMP	R3	ON	-	-	-	-	-	-	-	-	-	-	-	ON
HOT GAS VALVE(S)	R4	ON	ON	ON	ON	ON	ON	ON	ON	ON	ON	ON	ON	-
HARVEST ASSIST(S)														
WATER INLET VALVE	R5	ON	ON	-	-	-	-	-	-	-	-	ON	-	-
PURGE VALVE	R6	ON	-	-	-	-	-	-	-	-	-	-	-	-
NOTES:		TIMED SUMP FLUSH AND PURGE	INITIAL TIMED FILL 20 SECS. OR HIGH FLOAT SW OPENS	WAITING FOR CURTAIN SW.	CURT. SW. OPENS (MOMENT) ICE RELEASED	CURTAIN SW. CLOSES (MOMENT)	COOL THE EVAP PLATE AND FILL SUMP	5 MINUTE MIN. FREEZE TIME						

Figure 32.

BOARD LED SEQUENCE DURING OPERATION - BIN FULL (CURTAIN OR STAT)

TRANSITION TO BIN FULL SHUTDOWN		HARVEST				BIN FULL	
		PURGE ON ENTERING HARVEST	TIMED FILL	WAIT FOR HARVEST	CURT SW/BIN STAT OPENS	BIN FULL / PUMP DOWN (REMOTES)	SYSTEM HOLD
COMPONENTS	RELAY #						
FAN(S) W/FAN CYCLE	R1 (A/W)	-	-	-	-	-	-
LIQ. LINE VALVE	R1 (REM)	ON	ON	ON	ON	-	-
CONTACTOR/ COMPRESSOR/ REM. COND. FAN	R2	ON	ON	ON	ON	ON (PUMP DOWN)	-
WATER PUMP	R3	ON	-	-	-	-	-
HOT GAS VALVE(S) HARVEST ASSIST(S)	R4	ON	ON	ON	ON	-	-
WATER INLET VALVE	R5	ON	ON	-	-	-	-
PURGE VALVE	R6	ON	-	-	-	-	-
NOTES:		TIMED SUMP FLUSH AND PURGE - APPROX 7 SEC.	INITIAL TIMED FILL 20 SECS. OR TO HIGH FLOAT SW. OPEN	WAITING FOR CURTAIN SW. OR TIME	ICE HARVESTED - CURT/BIN STAT REMAIN OPEN	CURT OR BIN STAT REMAIN OPEN - UNIT SHUT DOWN (REMOTES) PUMPDOWN APPROX 30 SEC)	BIN FULL WAIT FOR CURT/STAT TO CLOSE

Figure 33.



BOARD LED SEQUENCE DURING OPERATION - DIAGNOSTICS IN FREEZE CYCLE

The Diagnostic sequence is started by pressing both the Power and Clean buttons for 6 seconds.

DIAGNOSTICS	CONTROLLER STATES					
	AT START-UP			FREEZE		
	FROM OFF STATE - POWER LED RED SOLID	PURGE	FILL	PRES. EQ. EQUAL	PRESS. EQ. W/ COMPR.	FREEZE
COMPONENTS RELAY #						
FAN(S) W/FAN CYCLE	R1 (A/W)	-	-	-	ON	ON
LIQ. LINE VALVE	R1 (REM)	-	-	-	ON	ON
CONTACTOR/ COMPRESSOR/ REM. COND. FAN	R2	-	-	-	ON	ON
WATER PUMP	R3	ON	-	-	-	ON
HOT GAS VALVE(S)	R4	-	-	ON	ON	-
HARVEST ASSIST(S)		-	-	-	-	-
WATER INLET VALVE	R5	-	ON	-	-	-
PURGE VALVE	R6	ON	-	-	-	-
NOTES:	VERIFY CONFIG 1 (PUMP DOWN FOR REM ONLY)	VERIFY EMPTY SUMP; LOW FLOAT SW. CLOSED	HI FLOAT SW. SATISFIED	HOT GAS OPEN APPROX 5 SEC	CONTACTOR/COMPRESSOR STARTUP - HOT GAS CLOSES AFTER 5 SEC	5 MINUTE MIN. FREEZE TIME
		QUICK PRESS POWER AND CLEAN BUTTON ADVANCES TO NEXT STATE	QUICK PRESS POWER AND CLEAN BUTTON ADVANCES TO NEXT STATE		AT SUMP TEMP 36F. TURN OFF WATER PUMP FOR 20 SEC	LOW FLOAT SW. CLOSE TO INITIATE HARVEST

Figure 34.

BOARD LED SEQUENCE DURING OPERATION - DIAGNOSTICS IN HARVEST CYCLE

DIAGNOSTICS		CONTROLLER STATES					
		HARVEST					
		POWER LED DOUBLE SLOW FLASH RED					
		HOT GAS-HAA/ PURGE/ WATER INLET	HARVEST	CURT. SW. OPENS	HARVEST COMPLETE/ PUMP DOWN	COMPLETE	
COMPONENTS	RELAY #					POWER LED RED SOLID	
FAN(S) W/FAN CYCLE	R1 (A/W)	-	-	-	-	DIAGNOSTICS COMPLETE	
LIQ. LINE VALVE	R1 (REM)	ON	ON	ON	-	-	
CONTACTOR/ COMPRESSOR/ REM. COND. FAN	R2	ON	ON	ON	ON (REM ONLY)	-	
WATER PUMP	R3	ON	-	-	-	-	
HOT GAS VALVE(S)	R4	ON	ON	ON	-	-	
HARVEST ASSIST(S)							
WATER INLET VALVE	R5	ON	-	-	-	-	
PURGE VALVE	R6	ON	-	-	-	-	
NOTES:		TIMED RINSE AND PURGE APPROX 7 SEC	WAITING FOR CURTAIN SW. OR TIME	ICE RELEASED	CURT. CLOSES, VERIFY CONFIG 1 (PUMP DOWN FOR REM ONLY)	OFF STATE	
QUICK PRESS POWER AND CLEAN BUTTON ADVANCES TO NEXT STATE							
OFF STATE							

Figure 35.

BUTTON FUNCTIONS			
INITIAL STATE	BUTTONS PRESS		FUNCTION/NEW STATE OR MODE
	POWER	CLEAN	
OFF - POWER LED SOLID RED	QUICK	-	FREEZE
	3 SEC	-	INDICATE CODE REVISION
	-	QUICK	CLEAN CYCLE
	3 SEC	3 SEC	CLEAR ERROR CODES AND RESET COUNTERS (Single BLUE and YELLOW light flash when reset)
	6 SEC	6 SEC	RUN DIAGNOSTICS PROGRAM
BIN FULL ON CURT/STAT - POWER LED SOLID BLUE	6 SEC	-	MACHINE OFF
HARVEST - POWER LED SOLID BLUE	QUICK	-	MANUAL HARVEST 2 - FINISHES THEN SHUTS OFF
	6 SEC	-	MACHINE OFF IMMEDIATELY
CLEAN IN PROCESS - POWER LED SOLID RED & CLEAN LED SLOW FLASH YELLOW	-	QUICK	ADVANCE TO PURGE AFTER MINIMUM OF 5 MIN OF WASH
	6 SEC	-	MACHINE OFF - CLEAN IN PROCESS
CLEAN COMPLETE - POWER LED SOLID RED & CLEAN LED SOLID YELLOW	-	QUICK	MACHINE OFF
	QUICK	-	MACHINE OFF
ANY STATE	6 SEC	-	MACHINE OFF
DIAGNOSTICS - POWER LED DOUBLE FLASH RED	QUICK	QUICK	ADVANCE TO NEXT STATE
	6 SEC	-	MACHINE OFF
ERROR 1 (MAX FREEZE/MAX HARVEST) - POWER LED QUICK FLASH RED	3 SEC	-	INDICATE CODE REVISION
	3 SEC	3 SEC	CLEAR ERROR CODES AND RESET COUNTERS (single BLUE and YELLOW light flash when reset)
	6 SEC	6 SEC	RUN DIAGNOSTICS PROGRAM
ERROR 3 (WATER SYS FAILURE) - POWER LED RED & CLEAN LED YELLOW QUICK FLASH	3 SEC	-	INDICATE CODE REVISION
	6 SEC	-	MACHINE OFF
	3 SEC	3 SEC	CLEAR ERROR CODES AND RESET COUNTERS Single BLUE/YELLOW flash when reset)
	6 SEC	6 SEC	RUN DIAGNOSTICS PROGRAM
RINSE- POWER LED SLOW FLASH BLUE	QUICK	-	ADVANCE FREEZE
HARVEST VERIFICATION - POWER LED SLOW FLASH BLUE	QUICK	-	NO ACTION (CURTAIN SWITCH OPEN/CLOSE TO ADVANCE)
DEFAULT HARVEST - POWER LED SLOW FLASH BLUE	QUICK	-	NO ACTION (CURTAIN SWITCH OPEN/CLOSE TO ADVANCE)
COMPRESSOR DELAY (3 MINUTES) - POWER LED SLOW FLASH BLUE	QUICK	-	NO ACTION (COMPRESSOR WILL NOT RESTART FOR 3 MINUTES)
MANUAL HARVEST 1 - POWER LED QUICK FLASH BLUE	QUICK	-	CANCELS MANUAL HARVEST 1 - CONTINUES CYCLE
MANUAL HARVEST 2 - POWER LED QUICK FLASH BLUE	QUICK	-	CANCELS MANUAL HARVEST 2 - COMPLETES HARVEST AND CONTINUES OPERATION

Sump

The Sump holds the potable water for the Freeze Cycle. It is located under the Evaporator and accessible from the front of the unit. The Sump must be removed to access the Water Pump and the Float Switch Housing.

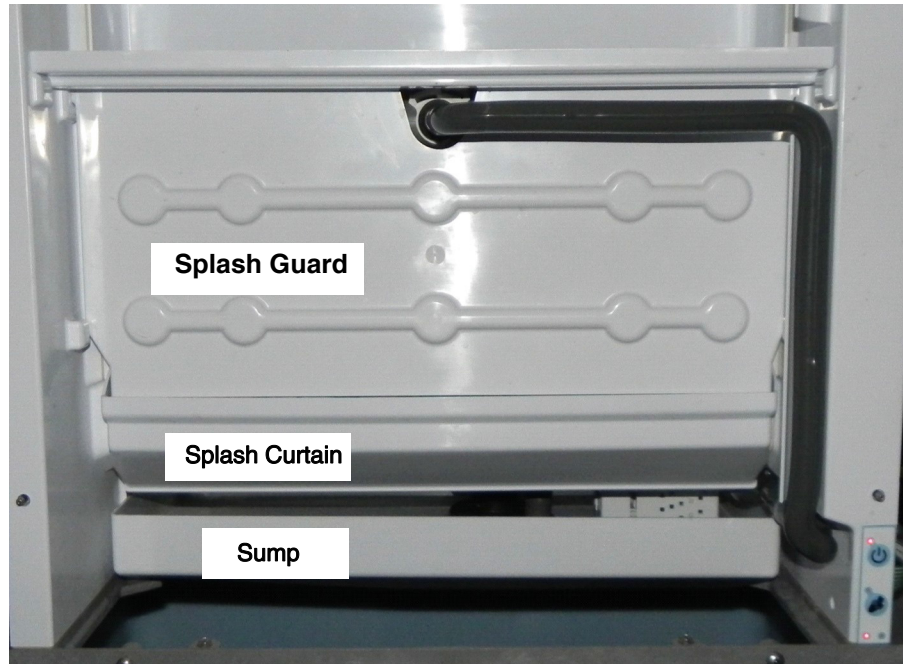

Figure 36.

Sump Removal

First remove the Splash Curtain and Splash Guard.



Figure 37.

Disconnect Water Pump Tube as shown above and tuck backside of tube into the Sump

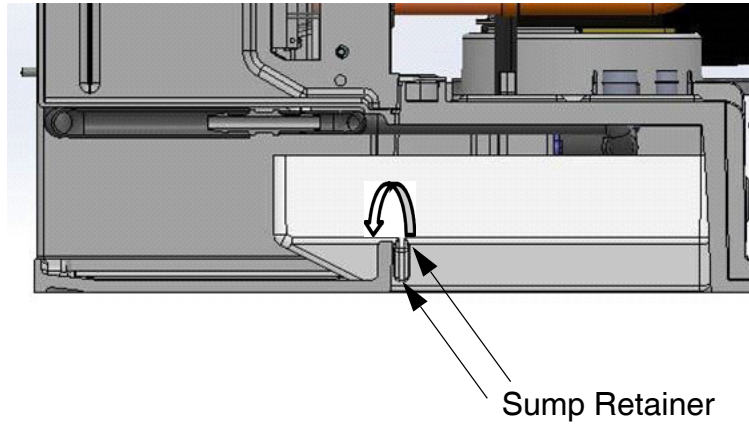

Figure 38.

Lift front of Sump and pull forward to clear the Sump Retainers from the frame.

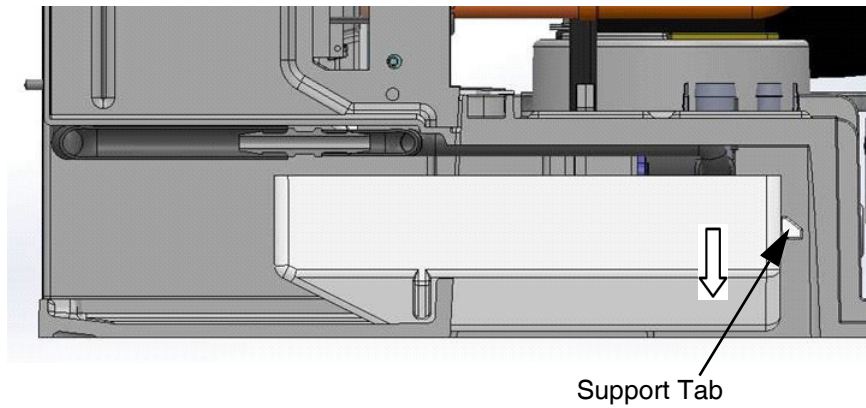

Figure 39.

With the Support Tabs now clear of the frame, allow the back of the Sump to fall clear of the frame.

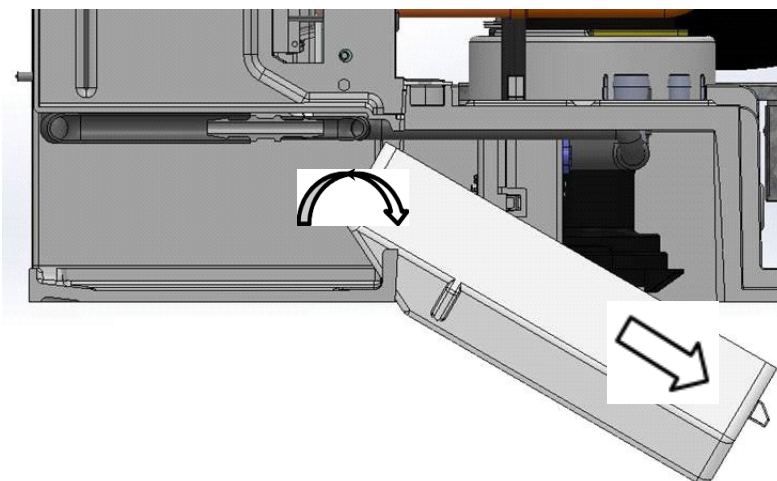

Figure 40.

Again lift the front of the Sump and push towards the back and down until Sump is clear of the frame. Turn the Sump sideways and remove through the ice drop zone.

To re-install, reverse process making sure to tuck Water Pump Tube into Sump as lift Sump into place.

Float Housing Assembly

The Float Switch Housing Assembly contains the High and Low Float Switches along with the Sump Thermistor. See below for function of each. See also Sequence of Operation pg. 12

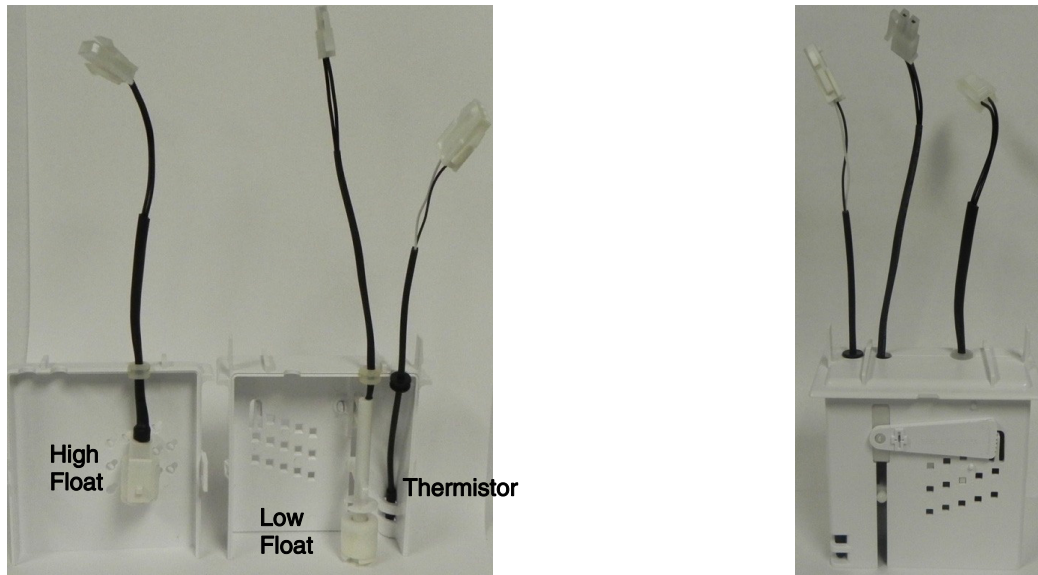
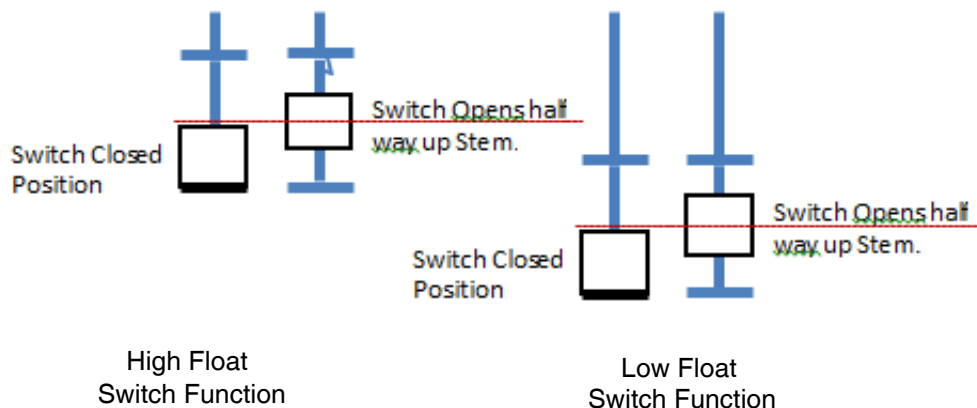

Figure 41.



High and Low Float Switch Operation

The High Float Switch is used to control the water level for ice making, cleaning and sanitizing. The Float will rise with the water level, opening the contact of the switch and signal the Board to close the Water Inlet Valve. The LED associated with the High Float switch will be ON when the contacts of the switch are closed, and will turn OFF when the contacts open. The Low Float Switch is used to determine when the unit is ready to go into the Harvest Cycle during ice production and when the Sump has been emptied of cleaner or sanitizer during the Cleaning Cycle. The LED associated with the Low Float Switch operates the same as the LED for the High Float Switch. The LED will ILLUMINATE when the contact of the float are closed and will turn OFF when the contacts are open. The Thermistor is used to measure the temperature of the water in the Sump during the Freeze Cycle. During the first 3 cycles following a full bin shut down or being turned on (initial start-up), the unit will perform an “Anti-slush” shutdown of the Water Pump for 20 seconds when the water temperature reaches 36 degrees F to reduce the possibility of the water in the Sump slushing. The unit will perform an anti-slush shut down of the Water Pump any time the water temp reaches 28 degrees F.

Troubleshooting

When the High and Low Floats are in the down position, the contacts for the switches are closed and the LED's on the Board should be illuminated.

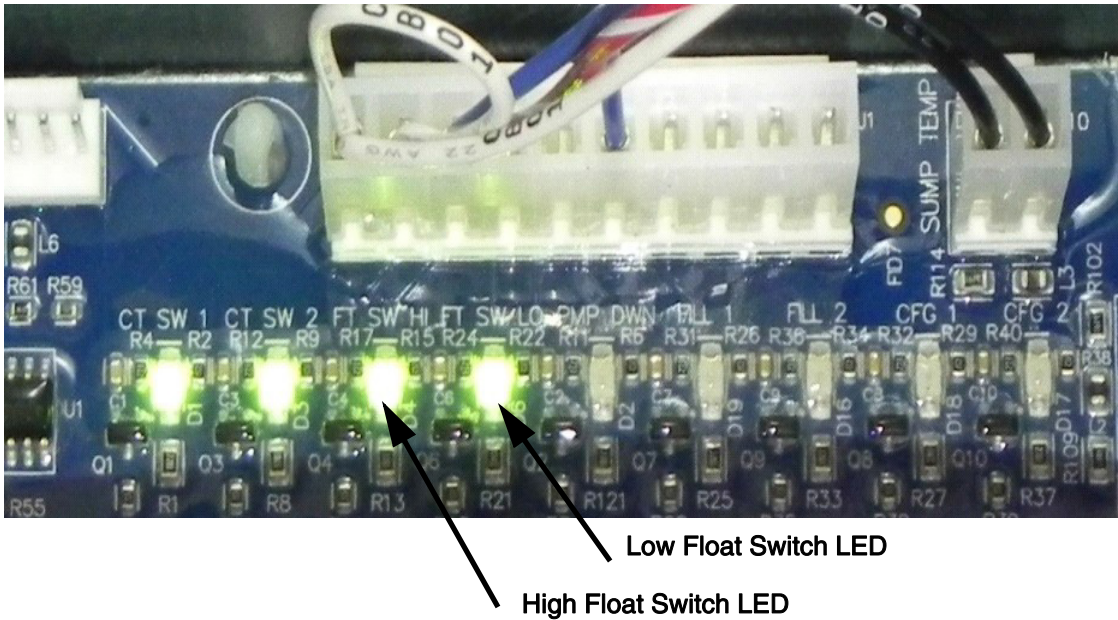

Figure 42.

As the water level rises, the floats rise with it and the contacts of the switches will open and the LED's on the Board will go OFF. This can be verified by removing the Sump and checking first the LED's on the Board. Without the presence of water, both floats should be in the down position and the LED's on the Board should be illuminated. If one or both LED's are OFF, disconnect the Float Switches at the connectors along with the Thermistor and remove the Float Housing by gently pulling down on it from the ice drop zone.

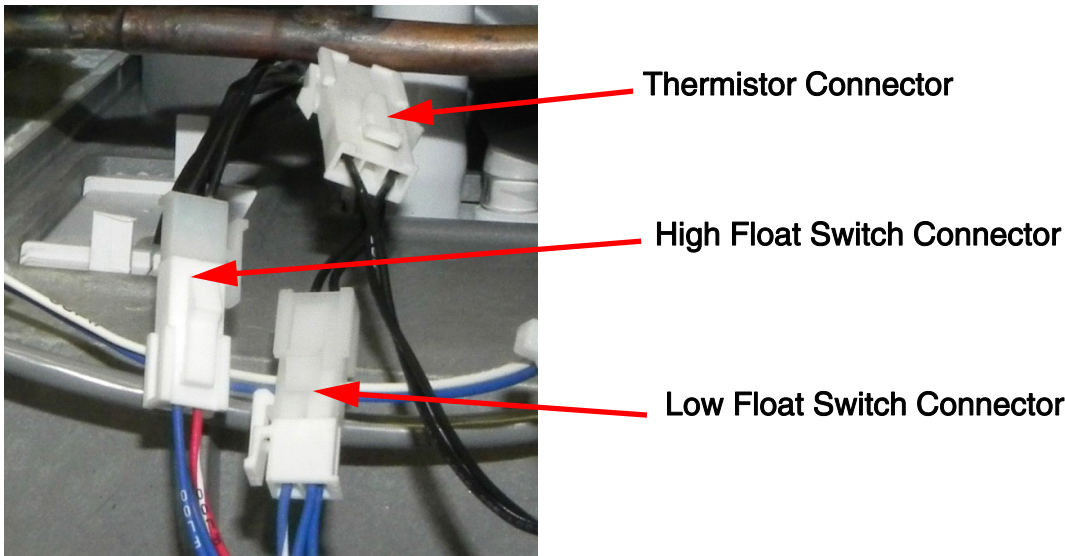

Figure 43.

Open the housing and examine each float for movement of the float and cleanliness. With a meter set on continuity, verify the contacts on the float open and close with movement of the float. If float is clean and contacts do not change with float movement, replace Float Switch Housing Assembly. If one or both of the LED's remain OFF with Float Switches that are known to be good, the Board or Wiring Harness may be the issue.

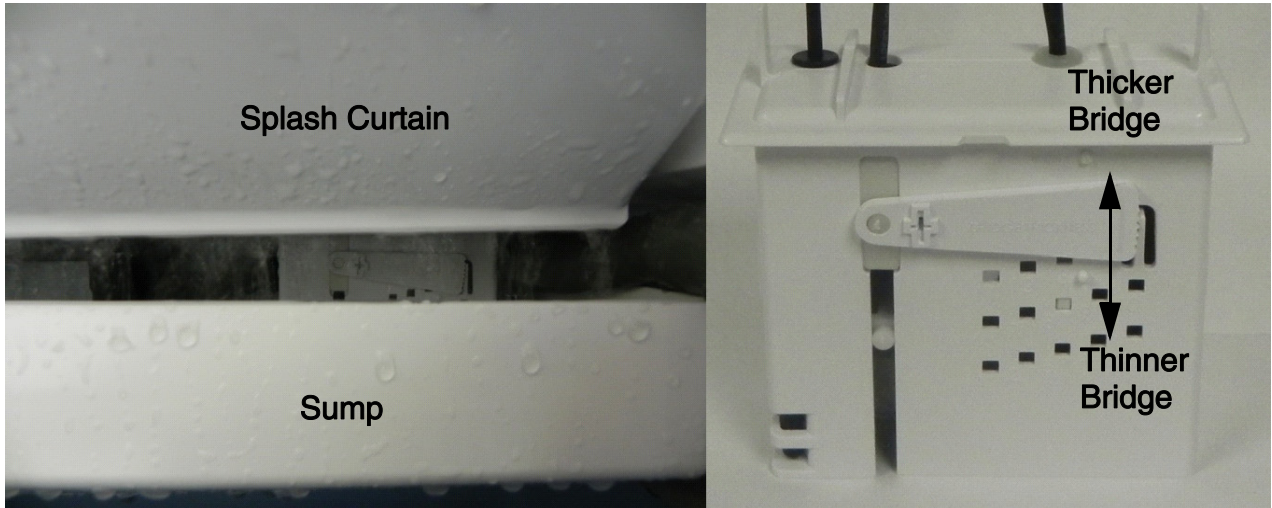

Figure 44.

The Bridge Thickness on units under 400# production should be 3/16" while units over 400# production should be 1/8" thick when measured across the middle of the plate. Minor Adjustments can be made to the bridge thickness by moving the Water Level Adjustment Arm of the Float Housing up for a thicker bridge or down for a thinner bridge. This adjustment can be made at any time during the freeze or defrost cycle and the results verified on the following cycle.

WATER PUMP

Operation

Relay 6 on the Board (LED ON) energizes the Water Pump after the 30 second Pre-Chill of the Evaporator during the Freeze Cycle. In the first 3 Freeze Cycles after a shutdown (turned OFF or Bin Full) the Water Pump will perform a shutdown for 20 seconds to help prevent the Sump from slushing. The Water Pump will then be energized to complete the Freeze Cycle (see Sequence of Operations pg. 12) The Water Pump is active continuously during the Cleaning Cycle after the Sump is filled (see Cleaning Instructions pg. 59).

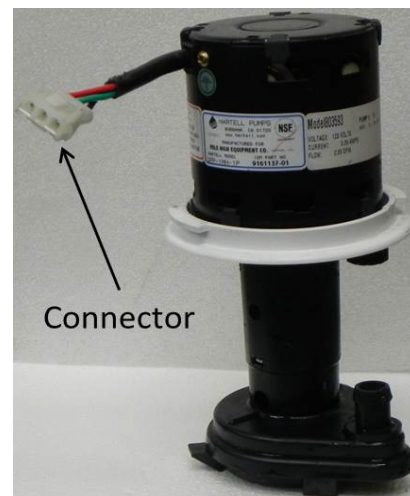

Troubleshooting

If Relay 6 LED is ON but the Water Pump does not run, verify line voltage between the Yellow and Blue wires on the Molex. If line voltage isn't found, verify connection of Molex to Board and reverify. If no voltage is found, the issue is the Board. If line voltage is found, verify line voltage at Water Pump connector. If no voltage found, the issue is the wiring or connectors. If line Voltage is found, but Water Pump won't spin, the issue is the Water Pump. Clean or replace as required.

When verifying voltage out of Board, check at the Blue and Yellow wires.

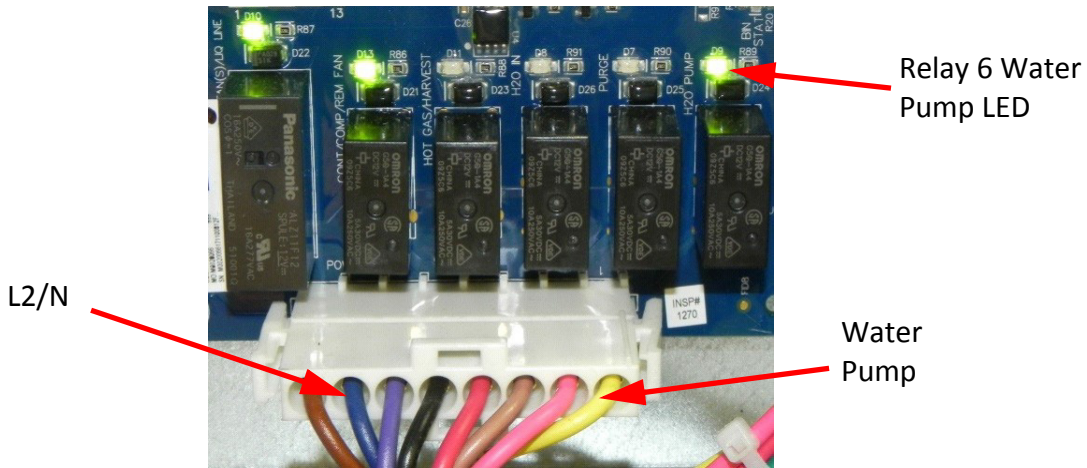

Figure 45.

Voltage can also be checked at the connector at the Water Pump.

Water Pump Removal

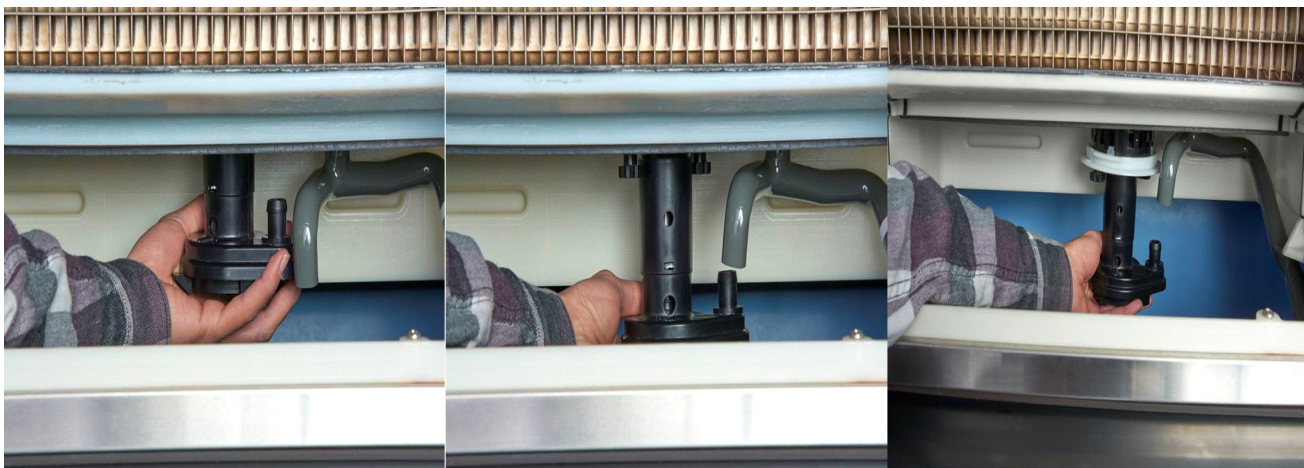

Figure 46.

The “foot” of the Water Pump points towards the right front corner of the unit. Grasp the foot and turn counter clockwise. When the foot points towards the right rear corner, you will feel the weight of the pump as the collar clears the base connections. Lower the Water Pump and disconnect. Reinstall the Water Pump by first making the electrical connection, the push Pump up pointing the Foot at the right rear corner and turn clockwise to secure.

WATER DISTRIBUTION TUBE

The Water Distribution Tube has an inner tube and an outer tube. The water enters through the inner tube and sprays the water up into the outer tube relieving the pressure on the water. Gravity takes over and the water runs out the outer tube holes pointed down. The water runs smoothly and evenly over the Evaporator.



Figure 47.

Removal and Disassembly

Disconnect Water Pump Tube from Water Distribution Tube

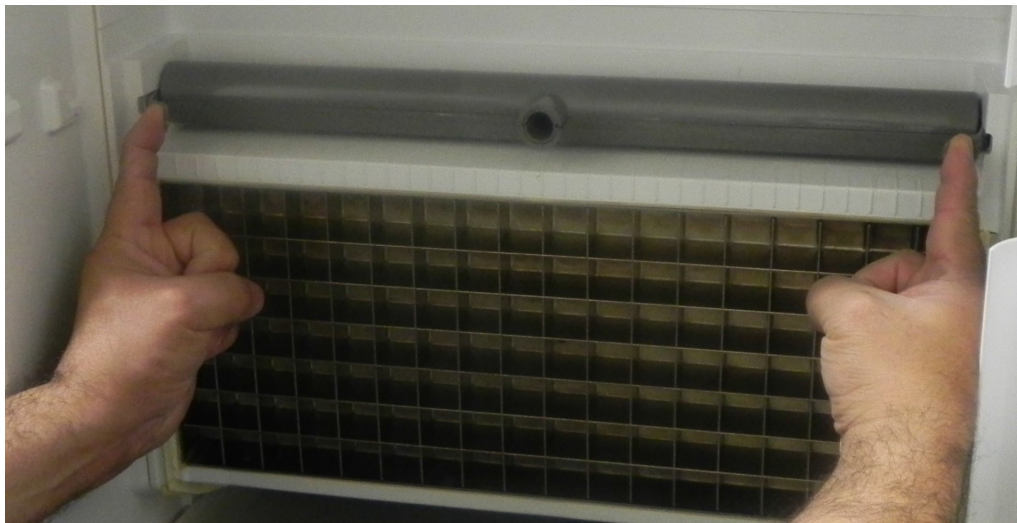

Figure 48.

Gentle squeeze the tabs inward on the Water Distribution Tube and forward towards the front of the unit.

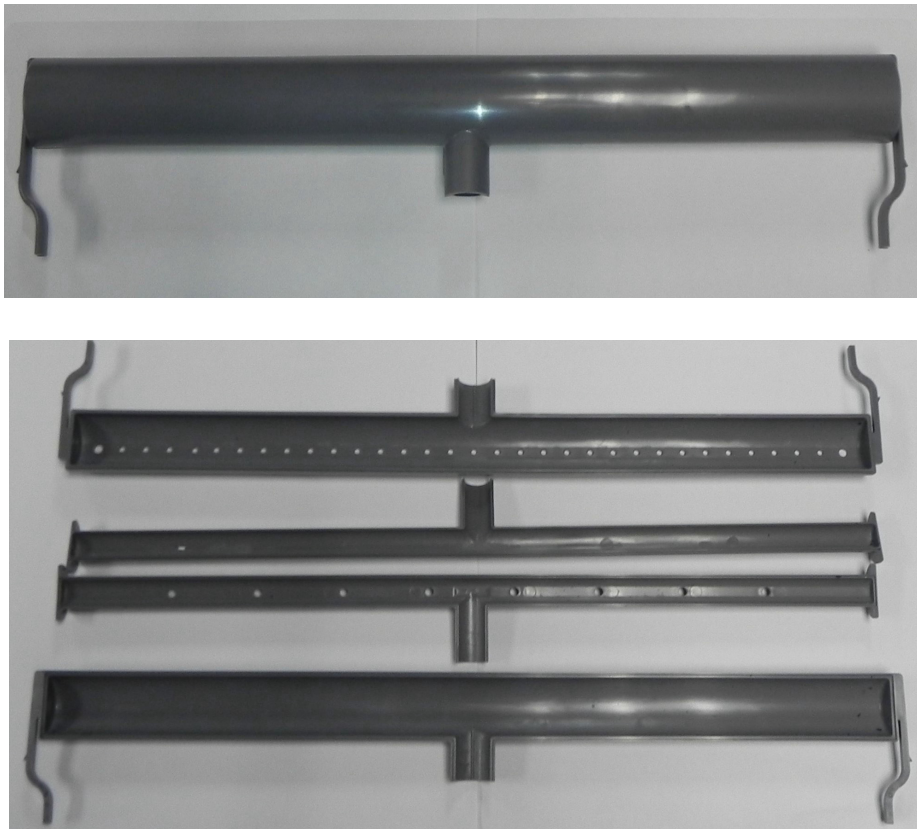

Figure 49.

The Water Distribution Tube comes apart easily. It should be taken apart and cleaned regularly along with the rest of the unit. The pieces are Pokeyoke, meaning it only goes back together one way.

WATER INLET VALVE

Operation

Relay 4 on the Board (LED ON) energizes the Valve first on initial startup to fill the Sump until the contacts of the High Float Switch open, indicating a proper amount of water for ice making. The purpose is to verify water supply before starting the unit. After the initial cycle is complete, the Valve will be energized during the Harvest Cycle and if needed, re-energized during the Pre-Chill to complete filling the Sump (See Sequence of Operation pg. 12). In either case, Relay 4 will be illuminated when Water Inlet Valve is energized. During the Cleaning and Sanitizing Cycle the Water Inlet Valve will be energized several times during the rinse and purge portion of the cycle (see Cleaning Instructions pg. 59).

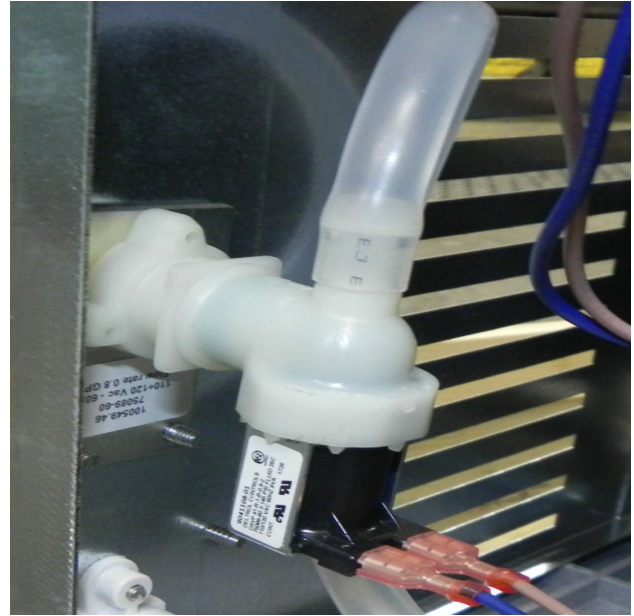

Figure 50.

Troubleshooting

The maximum fill time allowed to open the contacts of the High Float Switch is 5 minutes. If Relay 4 is illuminated and the Water Inlet Valve doesn't open, verify water supply to the unit, then check for line voltage between the Tan and Blue wires on the Molex. If line voltage is not present, the issue is the Board. If line voltage is present, check for line voltage at the Water Inlet Valve coil. If no line voltage is present, the issue is the wiring or connectors. If line voltage is present, check resistance of coil. No resistance = open coil, replace Valve. If coil checks out, verify Water Inlet Valve for cleanliness and clean or replace as needed. Also verify incoming water supply and for plugged filters.

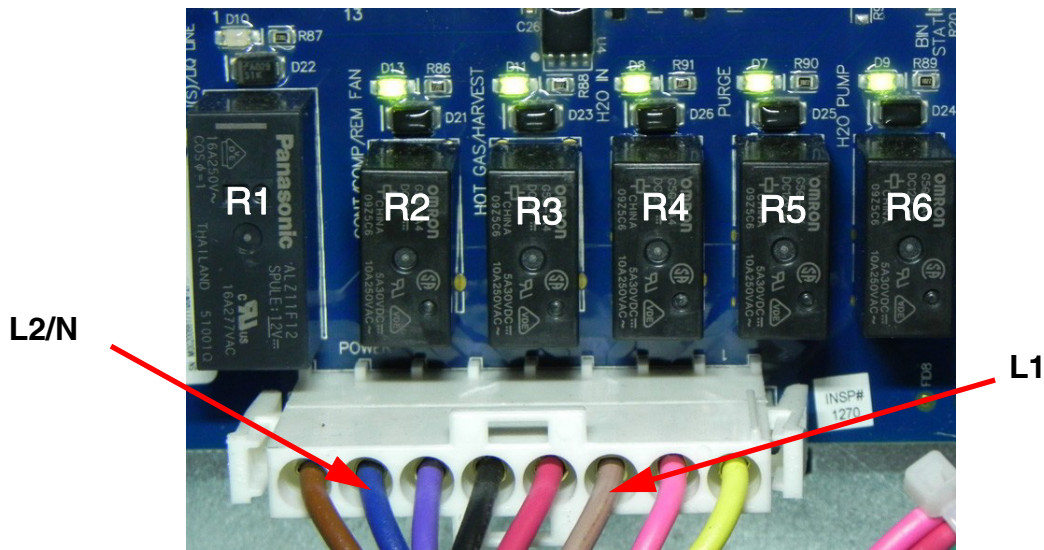

Figure 51.

Voltage can also be verified at the connector at the coil of the Water Inlet Valve.

PURGE VALVE

Operation

The Purge Valve is located in the back of the Evaporator. The Valve should open when energized by Relay 5 on the Board (LED ON) during the Harvest Cycle to help empty the mineral laden water (see Sequence of Operation pg. 12) and during the Cleaning/Sanitizing Cycle (see Cleaning Instructions pg. 59).



Figure 52.

Troubleshooting

The Purge Valve is located in the back of the Evaporator. The Valve should open when energized by Relay 5 on the Board (LED ON) during the Harvest Cycle to help empty the mineral laden water and during the Cleaning/Sanitizing Cycle. If Purge Valve fails to open with Relay 5 LED illuminated, unplug Connector at coil of Valve and check for line voltage. If none is found, check output voltage at Molex at Board between Pink and Blue wires. If no voltage is found, the Board is the issue. If output voltage is found, wiring between Molex and connector at Valve is the issue.

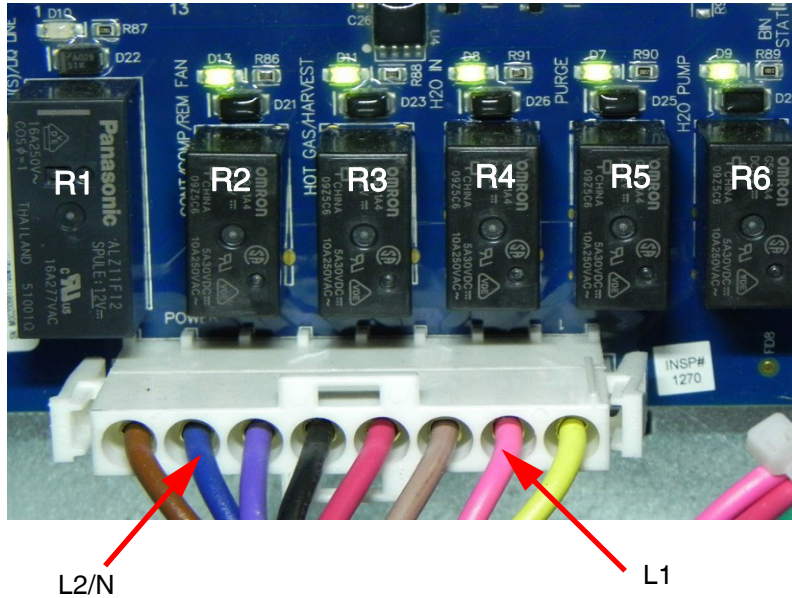

Figure 53.

Voltage can also be verified at the connector at the coil on the Purge Valve.

HARVEST ASSIST ASSEMBLY/HOT GAS VALVE

Operation

The Harvest Assist Assembly is mounted to the back of the Evaporator Assembly. It is energized by Relay 3 along with the Hot Gas Valve. As the unit enters the Harvest Cycle, Relay 3 will illuminate indicating voltage is being sent to the Harvest Assist Assembly and the probe will be pushed forward to meet the ice slab. As the Evaporator warms, the Probe on the Harvest Assist will move forward to help release the ice from the plate. As the ice slab falls it will open the Magnetic Curtain Switch contacts. Relay 3 will then be de-energized and the Harvest Assist will automatically return to the starting position.

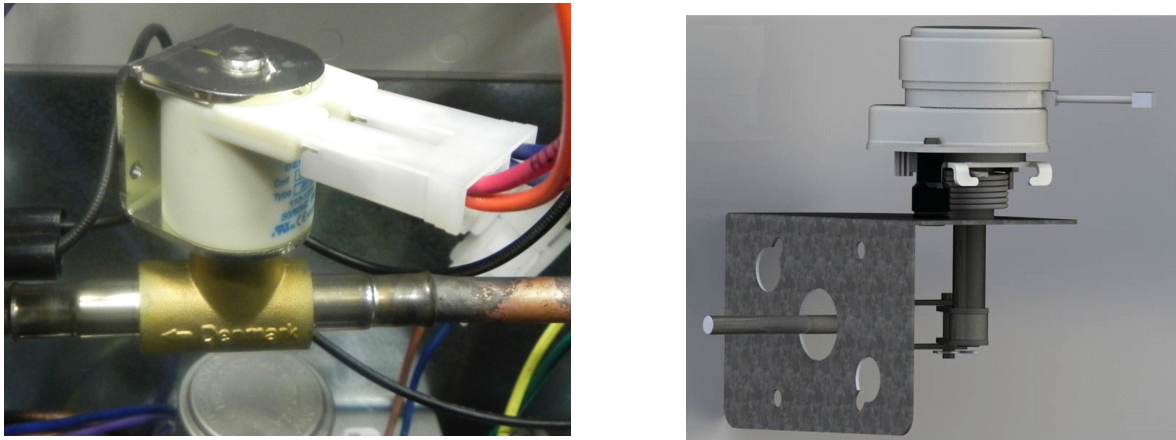

Figure 54.

Troubleshooting

The Harvest Assist Assembly is energized with the Hot Gas Valve throughout the Defrost Cycle by Relay 3. To quickly verify operation, put the unit into Diagnostics program by pressing both the Power and Wash buttons for 6 seconds, then quick press BOTH the Power and Clean buttons until the Harvest Cycle is initiated (R2 - R6 LED's above component Molex should illuminate). Verify LED for Relay 3 is illuminated and check voltage between the Blue and Red wires at Molex. If no voltage is present, the Board or Molex may be the issue. If voltage is verified, Check for voltage at the wiring connector for the Harvest Assist. If voltage is verified and the probe is not pushed forward, the issue is the Harvest Assist.

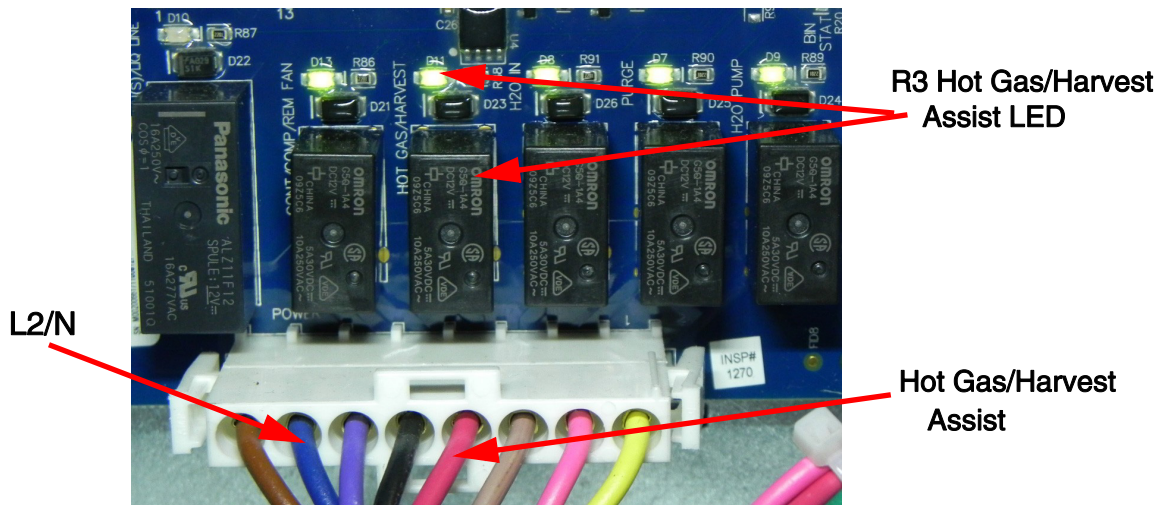

Figure 55.

EVAPORATOR ASSEMBLY

The nickel plated Evaporator Assembly has a copper core to assure good heat transfer. Water is pumped gently over the Evaporator during the freeze cycle for even ice formation.

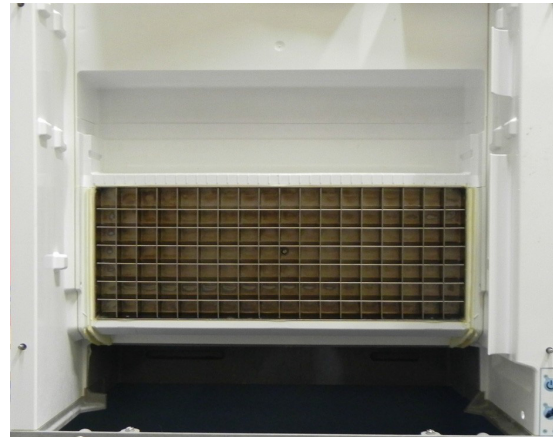

Figure 56.

Evaporator Operation

The Evaporator should be fully flooded with refrigerant for most of the freeze cycle to assure even ice formation. The serpentine on the back of the Evaporator starts at the bottom right corner of the plate (viewed from the front). The refrigerant lines run horizontally back and forth to the middle of the plate then rise along the left hand side to the top. The lines continue “serpentine” downward to the middle of the plate and exit the Evaporator.

Troubleshooting

The Evaporator should always have a nickel appearance. Should the Evaporator have a “rust” color after a thorough cleaning, the plating may have come off and a replacement may be required. A dull “rainbow shimmer” may indicate an improper cleaner was used on the unit. Only approved Nickel Safe ice machine cleaner should be used.

An improper ice formation can be caused by a water or refrigeration issue.

A dirty water system can cause poor water flow over the Evaporator resulting in improper ice formation. See pg 56 for Cleaning Instructions.

A refrigeration issue such as a low charge or restricted TXV could show on the Evaporator as ice forming on the bottom of the plate with thin to no ice forming on the top half. Verify refrigeration pressures on the Technical Specifications chart on pg. 60.

Should the ice slab resist coming off the plate, examine the Evaporator for lose of plating, pitting, mineral accumulation and/or loose horizontal dividers. Should any of the horizontal dividers separate from the base, replacement of the Evaporator is recommended.

While recovering the refrigerant from the unit, disconnect High and Low Float Switches, Thermistor, Curtain Switch and Push Pad ribbon and move the wiring clear of the area.

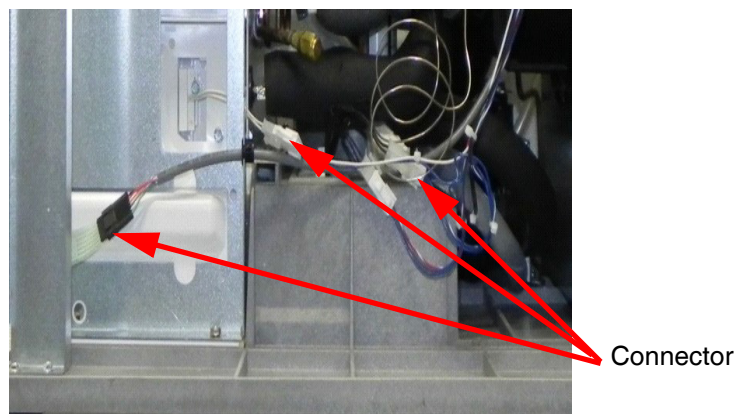

Figure 57.

Remove the Splash Curtain, Evaporator Cover, Top Evaporator Cover, Water Distribution Tube, Water Pump Tube and its connector, Sump, Water Pump, and Float Switch Housing Assembly.

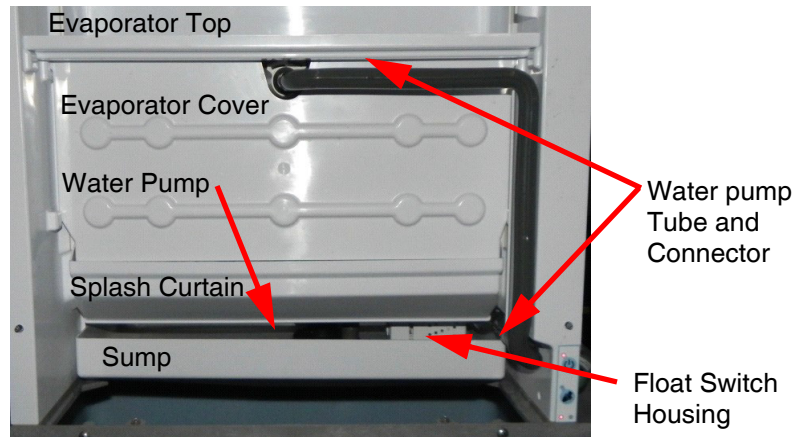
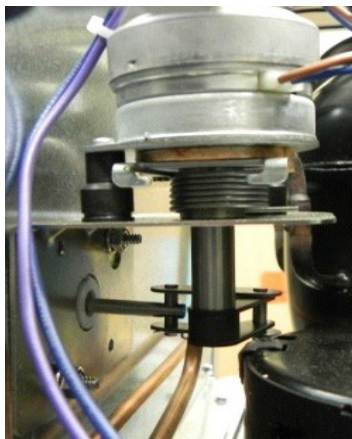

Figure 58.



Harvest Assist Assembly

Figure 59.



Purge Valve

Figure 60.

On the rear of the Evaporator Assembly, disconnect Harvest Assist Assembly, Purge Valve and Purge Tube and remove from unit.

Clip Zip Ties holding Service Port tubes to rear of Evaporator. Remove 3) 1/4" screws on right side, left side and center holding Evaporator Assembly to base.

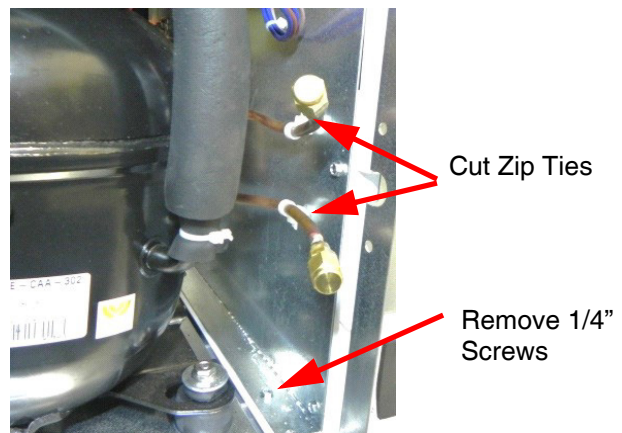
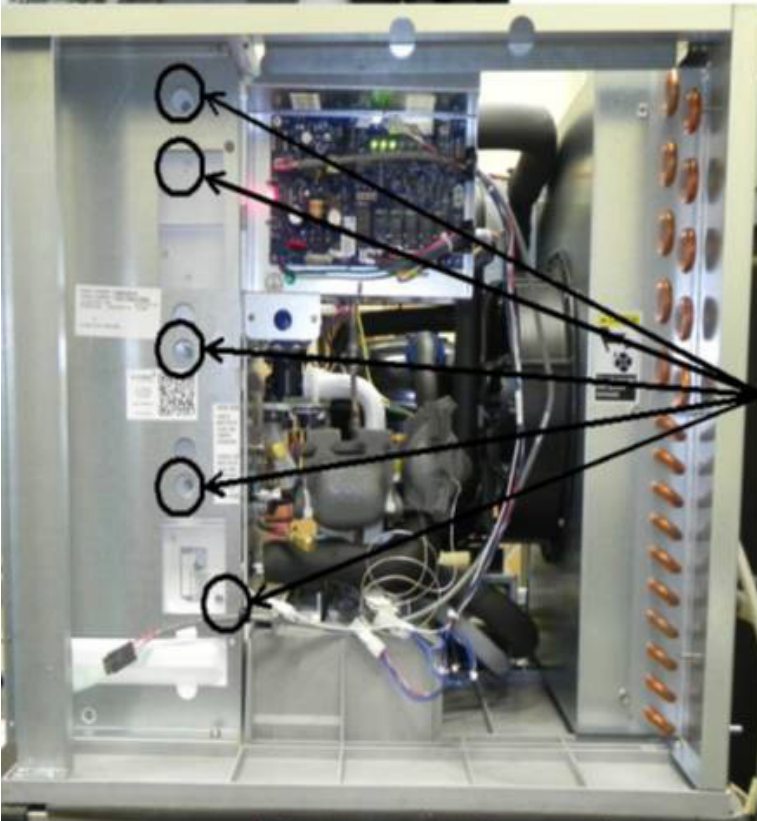

Figure 61.



Once unit is recovered, unsolder Evaporator refrigerant lines



Remove 5) 1/4" screws securing Evaporator to surround on right hand side of unit.



Remove 2) 1/4" screws where frame meets The base on the left hand side of the unit.

Figure 62.

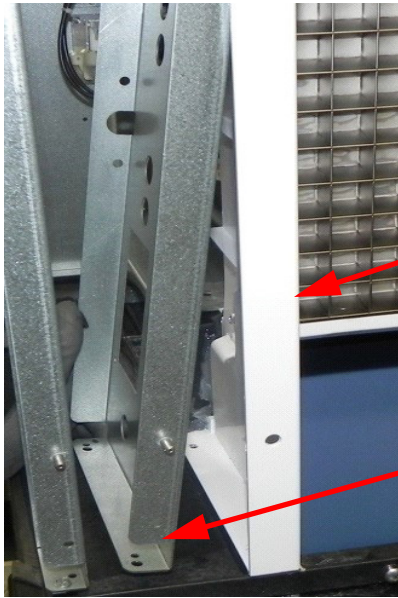

Surround

Pull Bottom of frame out to clear left hand surround.

Figure 63.

Grasp and remove Evaporator freeing the Left Hand side first. The Left Hand Surround will come out with the Evaporator; the Right Hand surround will be left in place. Once the Evaporator is out, separate the surround from the Evaporator by removing the five – 1/4” Screws on the Left Hand side of the Evaporator. Remove Curtain Switch on Right Hand side of Evaporator and place on new Evaporator and mount Left Hand Side surround on new Evaporator



Figure 64.

Remove old silicone from base where shown in picture. Run a 3/8” bead of silicone included with Evaporator kit to replace existing where surround and Evaporator meet on the base.

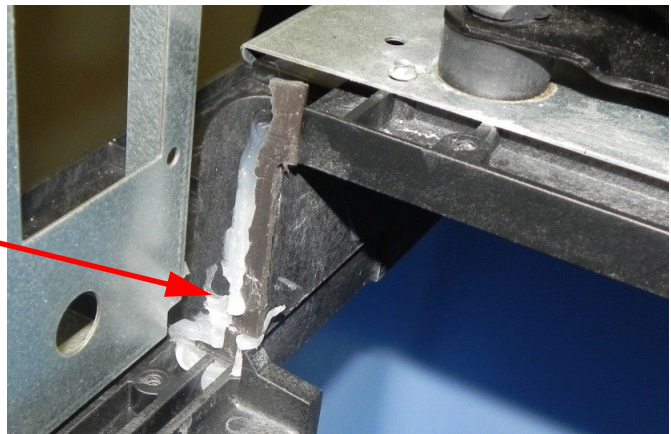

Figure 65.

Install Evaporator and reverse procedure for installation of components. Be sure to replace the Drieron all open system repairs.

MAGNETIC CURTAIN SWITCH

The Magnetic Curtain Switch is a proximity switch that closes the contacts when the Splash Curtain closes. LED's on the Board indicate a closed switch when illuminated.

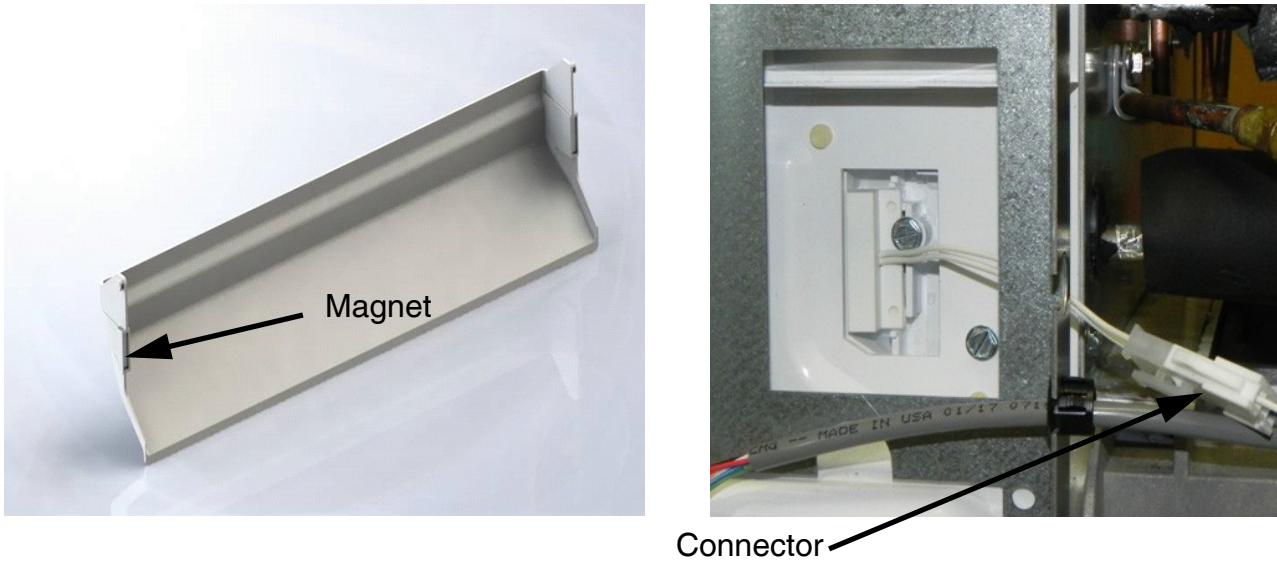

Figure 66.

Troubleshooting

Should the LED's on the Board be off when the Splash Curtain is closed, first verify the magnet is in place on the Splash Curtain and the Wiring Harness is properly connected at the Switch and at the Board. If all is verified, use a different magnet against the switch. If it still will not close, replace the Magnetic Curtain Switch.

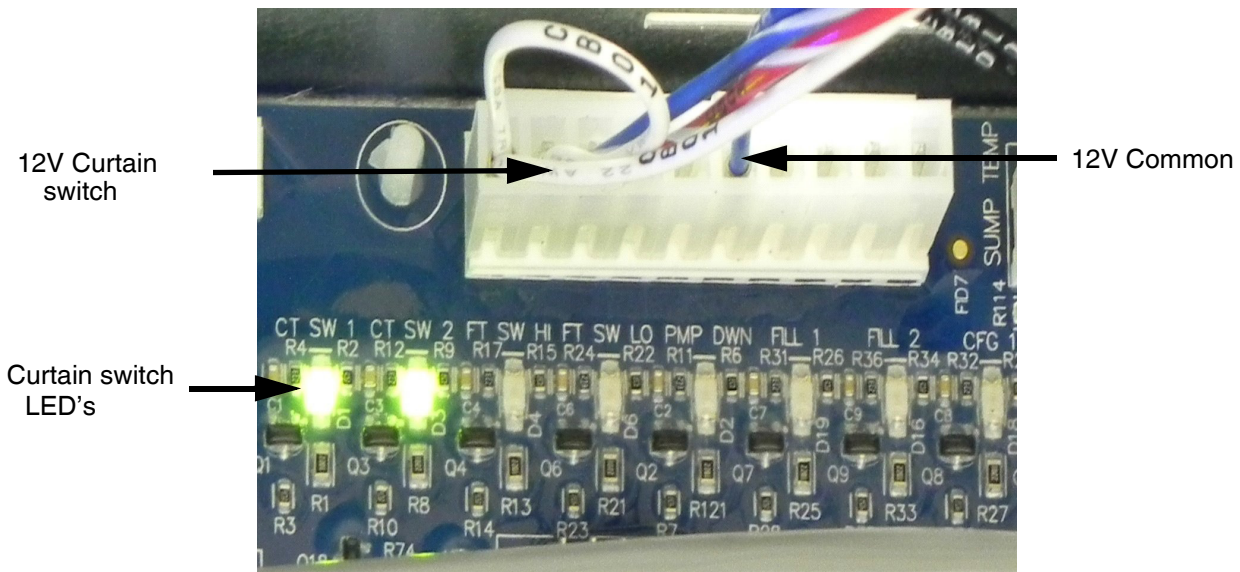

Figure 67.

HIGH PRESSURE CUT-OUT/FAN CYCLE CONTROL

High Pressure Cut-out (left)

The High Pressure Cut-out is set to open at 450 psig and de-energizes the Contactor as a safety on the unit.

Fan Cycle Control (right)

The Fan Cycle Control helps maintain head pressure in cooler ambient temps. The control closes at 250 psig, energizing the Fan Motor and opens at 200 psig.

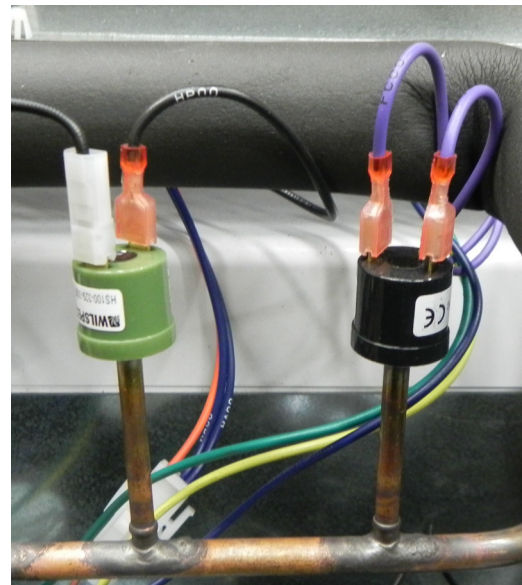

Figure 68.

Troubleshooting

High Pressure Cut-out

The High Pressure Cut-out opens at 450 psig to de-energize the Contactor and shutdown the Compressor. The control re-closes at 350 psig. Should the control open during the Freeze Cycle, the unit may go into Error 1 state, indicating the Freeze Cycle has run for more than 1 hour. To quickly check the unit operating pressure, run a Diagnostic Cycle with stub gauge on the unit. A dirty or blocked Condenser, failed Fan Cycle Control, failed Fan Motor, high side restriction or refrigerant over charge can be the cause.

Fan Cycling Control

The Fan Cycle Control closes on pressure rise at 250 psig and opens on pressure drop at 200 psig to maintain head pressure in cooler ambient conditions. The cut-in and cut-out should never be erratic. Should the contacts of the control close and/or open outside these parameters, the control should be replaced.

HIGH TEMP SAFETY

The High Temp Safety is a bi-metal thermostat strapped to the line at the outlet of the Hot Gas Valve. Should the Hot Gas Valve stick open and the refrigerant line reach 180 degrees F., the High Temp Safety would open, dropping power to the Contactor and shut down the Compressor. When the line temperature drops below 120 degrees F., the con? tacts of the Safety will close, allowing power to the Contactor.

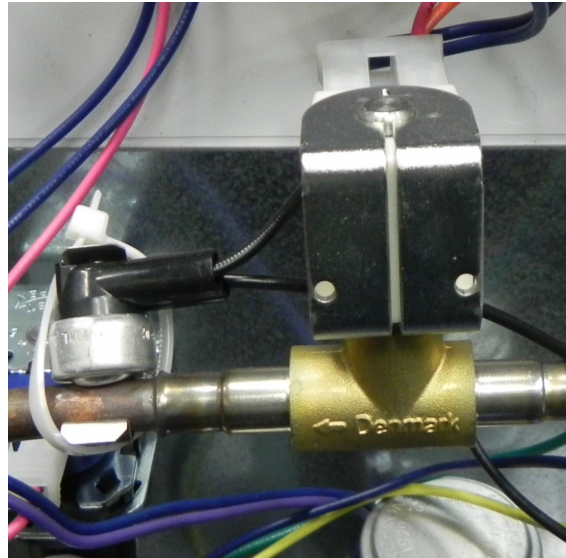

Figure 69.

Troubleshooting

Should the Compressor not run with the R2 relay LED illuminated, verify if High Pressure Cutout is closed and Contactor coil is good. The discharge line from the Hot Gas Valve should be cool to the touch during a freeze cycle. With a line temperature below 120 degrees F. (confirming hot gas valve is closed), the contacts in the High Temp Safety should be closed. Disconnect both leads of the High Temp Safety and check for continuity. If open with a cool line, the safety will need to be replaced.

FAN MOTOR

Operation

The Fan Motor (Self Contained Air Cooled Units) is Mounted to the Fan Shroud covering the Condenser at the rear of the unit. It is energized by Relay 1 and controlled by the Fan Cycling Switch. The Switch should close at 250 psi of head pressure and power the Motor. The Fan Cycle Switch should open at 200 psi of head and the Fan Motor will de-energize.



Figure 70.

Troubleshooting

When the Fan Motor is inoperable or cycling outside of the operational parameters, first verify the LED for Relay 1 is illuminated, indicating the Board is calling for the Fan Motor to run. If the unit is in the Freeze Cycle and the LED is not illuminated, the issue may be the board. If it is illuminated, check voltage between the Violet and Blue with a meter. Line voltage should be shown. If inappropriate voltage is shown, verify Molex connection at the Board and correct if loose. If still no voltage out, replace the Board. If voltage is verified, check contacts of Fan Cycle Switch for voltage then check contacts which should be closed at pressures above 250 psi. If open in these conditions, jump control. If Fan Motor comes on, issue is Fan Cycling Control. If Motor does not come on, check connection at Motor. If verified, the issue is the Fan Motor.

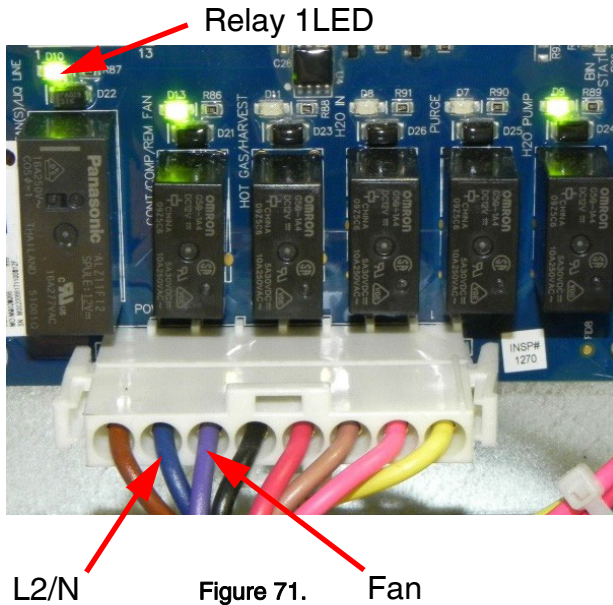
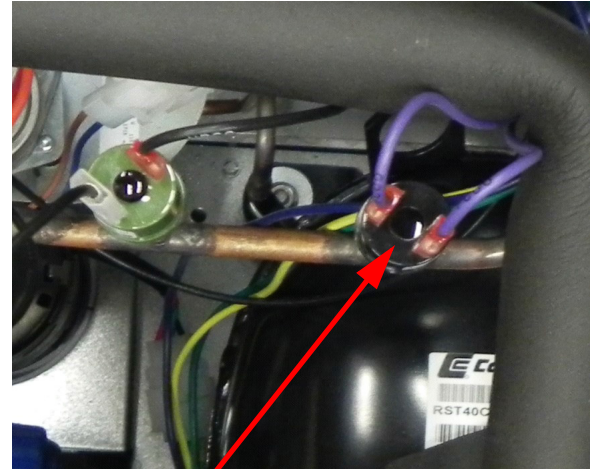

Figure 71.



Fan Cycle Control

Figure 72.

REFRIGERATION SECTION

The Refrigeration Section on a CNM Cuber contains the Compressor, Thermostatic Expansion Valve, Hot Gas Valve and Condenser. Remote systems also utilize a Mixing Valve (LAC), Liquid Line Solenoid and Receiver.

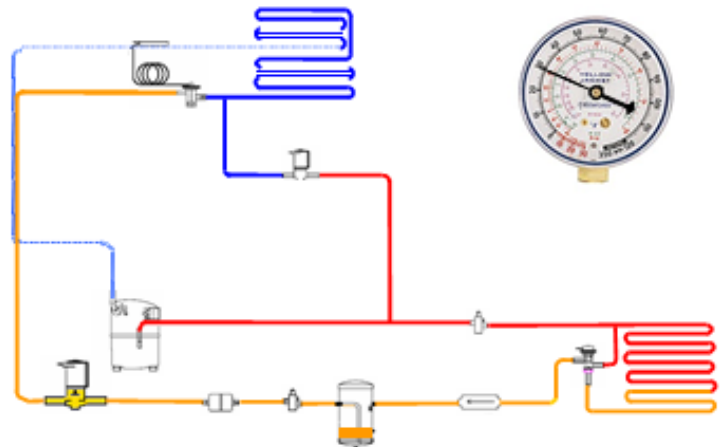

Figure 73.

Refrigeration Section Operation

The Compressor drives the refrigeration system. Cornelius uses a Thermostatic Expansion Valve to control refrigerant flow through the Evaporator.

Troubleshooting - System

When troubleshooting the refrigeration system, always use stub gauges to limit the amount of refrigerant lost during connecting and disconnecting.

Always verify the refrigeration systems operating pressures when diagnosing any refrigeration component. The Compressor should pull within 10% of the RLA when measured 5 minutes into the Freeze Cycle and greater than 70% of RLA during the Freeze Cycle to be considered efficient.

Thermostatic Expansion Valve

The Thermostatic Expansion Valve meters refrigerant through the Evaporator.

Troubleshooting - Expansion Valve

First verify proper system pressures and charge. Verify the TXV bulb is securely mounted at 7 degrees off vertical and well insulated. Generally a low suction pressure with a normal head pressure will show as poor ice formation top to bottom on the Evaporator and indicate a low side restriction such as at the TXV. Should suction run high or not drop, verify bulb connection to suction line and look for sweating or frosting on the dome of the Compressor indicating TXV is stuck open.

Hot Gas Valve

The Hot Gas Solenoid Valve opens to provide gas to the Evaporator during the Harvest Cycle.

Troubleshooting - Hot Gas Valve

Should the valve not open at the initiation of the Harvest Cycle (R3 LED ON), verify voltage at the coil of the solenoid. If no voltage is present, verify Molex is properly connected at Board and Voltage is present at Molex. If Voltage is present at coil, verify resistance through coil. If coil shows open, replace the coil. If coil checks out, place magnetic donut on top of coil. If valve will not open, replace Hot Gas Valve body. Should suction pressure run high, check temperature of the inlet and outlet line of the Hot Gas Valve. Should be greater than 10 degree F. different. If less than 10 degrees F., the Valve is leaking and should be replaced. (See also pg.46).

Liquid Line Solenoid

The Liquid Line Solenoid opens to allow refrigerant to flow from the Receiver on Remote Systems. It is energized by R1 along with the Remote Fan Motors. Diagnosis of Liquid Line Solenoid is much the same as the Hot Gas Solenoid Valve (see above.)

Mixing Valve

The 220 psig. Mixing Valve (or LAC) Is used to maintain head pressure in low ambient .

Troubleshooting - Mixing Valve

In lower ambients, the Mixing Valve should be bypassing the Condenser to maintain head pressure. The inlet and outlet lines at the Condenser would be the same temp. in bypass mode. In warmer ambients the Mixing Valve is pushing refrigerant to the Condenser Coil and there would be approx. 20 degree F. temperature difference. A low charge would be identified by hot inlet and outlet lines at the Condenser and a hot Receiver. Always verify charge before condemning the Mixing Valve.

TECHNICAL SPECIFICATIONS

Model	Voltage/Hz/ Phase	Approx. Suction Press	Approx. Head Press	Avg. Batch Weight Half/Full	Approx Cycle Time 90/70 in Minutes	Avg. Water Usage per 100 lbs. Produced in Gallons		Min Circuit Ampacity	Max Fuse Size	kWH Used	Comp. LRA	Comp. RLA	Ref. Type	Charge in ounces
						Potable	Water Condenser							
0320A	115/60/1	50-30	175-400	3.025/3.375	18-23	20	179	11	15	6.69	50	8.1	R-404a	20
0320W	115/60/1	50-30	250	3.025/3.375	16-21	19.6	179	10.7	15	5.19	50	8.1	R-404a	13
0325A	220-240/50/1	50-30	175-400	3.025/3.375	19-24	22		6.9	16	7.32	29.9	5.1	R-404a	22
0330A	115/60/1	50-30	175-400	3.025/3.375	18-23	20	179	11	15	6.69	50	8.1	R-404a	20
0330W	115/60/1	50-30	250	3.025/3.375	16-21	19.6	179	10.7	15	5.19	50	8.1	R-404a	13
0335A	220-240/50/1	50-30	175-400	3.025/3.375	19-24	22		6.9	16	7.32	29.9	5.1	R-404a	22
0430A	115/60/1	50-30	175-400	5.025/5.65	22-26	19.8	185	11	15	5.43	50	8.1	R-404a	24
0430W	115/60/1	50-30	250	5.025/5.65	19-22	17.8	169	10.7	15	4.75	50	8.1	R-404a	14
0435A	220-240/50/1	50-30	175-400	5.025/5.65	20-24	20		8.7	16	5.97	37	6.3	R-404a	24
0436A	115/60/1	50-30	175-400	5.025/5.65	17-20	18	185	6.3	15	5.46	26.5	4.6	R-404a	24
0436W	115/60/1	50-30	250	5.025/5.65	20-24	17.7	185	6.1	15	4.37	26.5	4.6	R-404a	14
0520A	115/60/1	50-30	175-400	5.025/5.65	18-22	19.9	190	17.8	30	5.87	70	13.5	R-404a	20
0520W	115/60/1	50-30	250	5.025/5.65	15-18	20	181	17.4	30	4.7	70	13.5	R-404a	14
0525A	220-240/50/1	50-30	175-400	5.025/5.65	18-21	20		11.2	16	6.11	38	8.5	R-404a	22
0530A	115/60/1	50-30	175-400	5.025/5.65	18-22	19.9	190	17.8	30	5.87	70	13.5	R-404a	20
0530W	115/60/1	50-30	250	5.025/5.65	15-18	20	181	17.4	30	4.7	70	13.5	R-404a	14
0530R	115/60/1	50-30	220-400	5.025/5.65	17-21	19.6	181	20.1	30	6.21	70	13.5	R-404a	132
0535A	220-240/50/1	50-30	175-400	5.025/5.65	18-21	20		11.2	16	6.11	38	8.5	R-404a	22
0535W	220-240/50/1	50-30	250	5.025/5.65	16-19	19.5	190	11	16	5	38	8.5	R-404a	13
0535R	220-240/50/1	50-30	220-400	5.025/5.65	17-20	20		12	20	6.31	38	8.5	R-404a	132
0635A	220-240/50/1	50-30	175-400	5.025/5.65	16-19	20		8.1	16	5.72	37	5.8	R-404a	22
0636A	208-230/60/1	50-30	175-400	5.025/5.65	16-19	18.6	180	9.2	15	5.63	46	6.9	R-404a	20
0636W	208-230/60/1	50-30	250	5.025/5.65	14-16	19.2	180	9	15	4.27	46	6.9	R-404a	14
0636R	208-230/60/1	50-30	220-400	5.025/5.65	14-16	19		10	15	5.29	46	6.9	R-404a	132
0835A	220-240/50/1	50-30	175-400	7.15/8.10	16-19	18	130	10.8	16	4.88	58	7.8	R-404a	40
0835W	220-240/50/1	50-30	250	7.15/8.10	16-19	18	130	10.4	16	4.08	58	7.8	R-404a	28
0835R	220-240/50/1	50-30	220-400	7.15/8.10	16-19	18		11.4	16	4.52	58	7.8	R-404a	176
0836A	208-230/60/1	50-30	175-400	7.15/8.10	16-19	18	130	11.8	20	5.2	61	8.6	R-404a	40
0836W	208-230/60/1	50-30	250	7.15/8.10	16-19	18	130	11.3	20	4.32	61	8.6	R-404a	28
0836R	208-230/60/1	50-30	220-400	7.15/8.10	16-19	18		12.3	20	5	61	8.6	R-404a	176
0836G														
A	208-230/60/1	50-30	220-400	8.6	17-20	18		12.3	20	5.44	61	9	R-404a	38
1126R	208-230/60/1	50-30	220-400	7.15/8.10	11-15	18		12.8	20	5.13	61	9	R-404a	176
1135A	220-240/50/1	50-30	175-400	7.15/8.10	11-15	18		13.5	20	5.3	65	10	R-404a	36
1135W	220-240/50/1	50-30	250	7.15/8.10	11-15	18	130	13.1	20	4.31	65	10	R-404a	28
1135R	220-240/50/1	50-30	220-400	7.15/8.10	11-15	18		14.1	20	4.71	65	10	R-404a	176
1136A	208-230/60/1	50-30	175-400	7.15/8.10	11-15	18	130	12.2	20	5.2	61	9	R-404a	40
1136W	208-230/60/1	50-30	250	7.15/8.10	11-15	18	130	11.8	20	4.18	61	9	R-404a	28
1136R	208-230/60/1	50-30	220-400	7.15/8.10	11-15	18		12.8	20	5.13	61	9	R-404a	176
1137A	208-230/60/3	50-30	175-400	7.15/8.10	11-15	18		8.9	15	5.21	63	6.3	R-404a	40
1137W	208-230/60/3	50-30	250	7.15/8.10	11-15	18	130	8.5	15	4.17	63	6.3	R-404a	28
1137R	208-230/60/3	50-30	220-400	7.15/8.10	11-15	18		9.5	15	5	63	6.3	R-404a	176

Figure 74.

WIRING DIAGRAMS

CNM0320, 0330, 0430, 0436, 0520, 0530, 0636, 0836, and 1136 AIR AND WATER COOLED UNITS

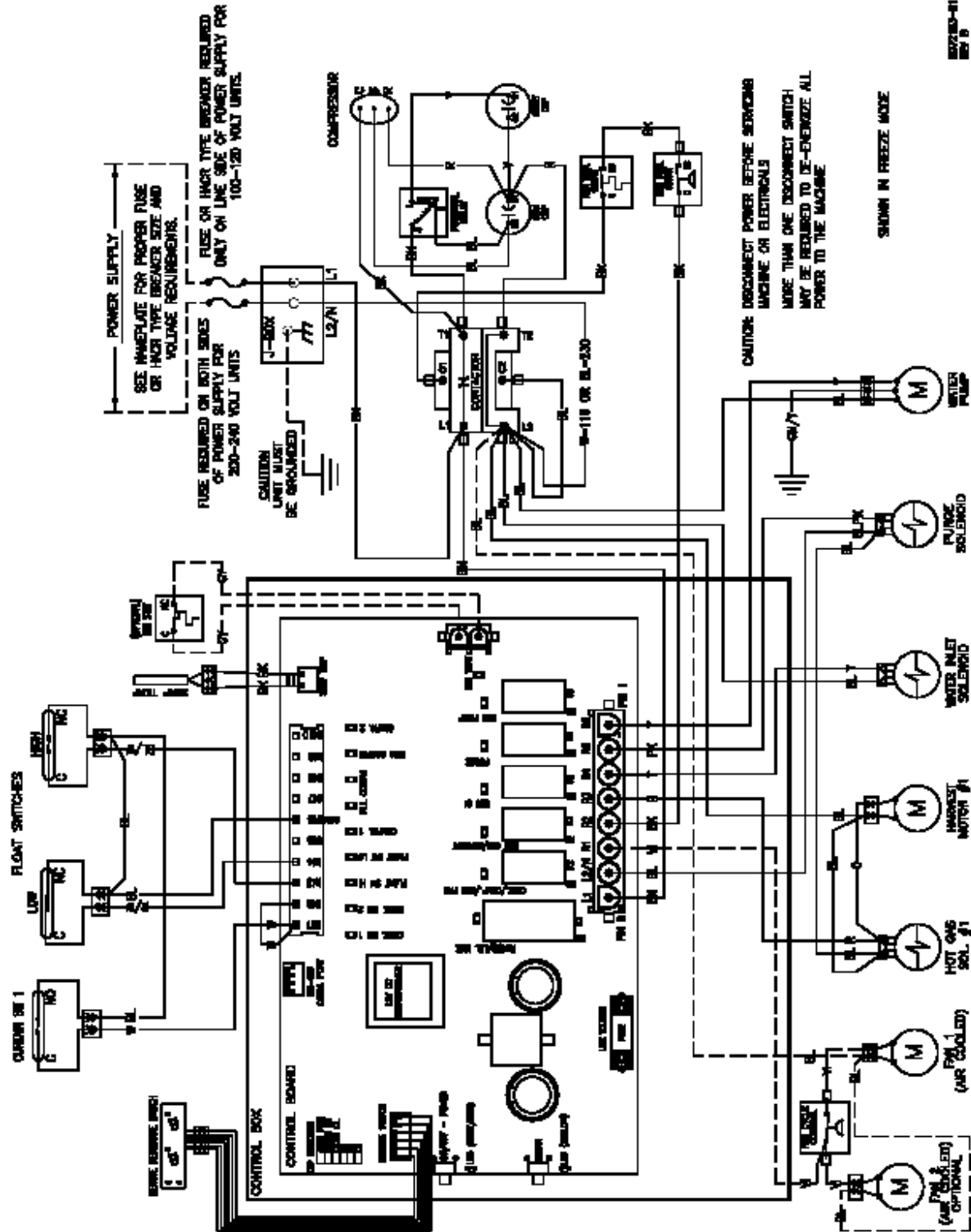

Figure 75.

CNM0530, 0636, 0836, 1126 and 1136 REMOTE COOLED UNITS

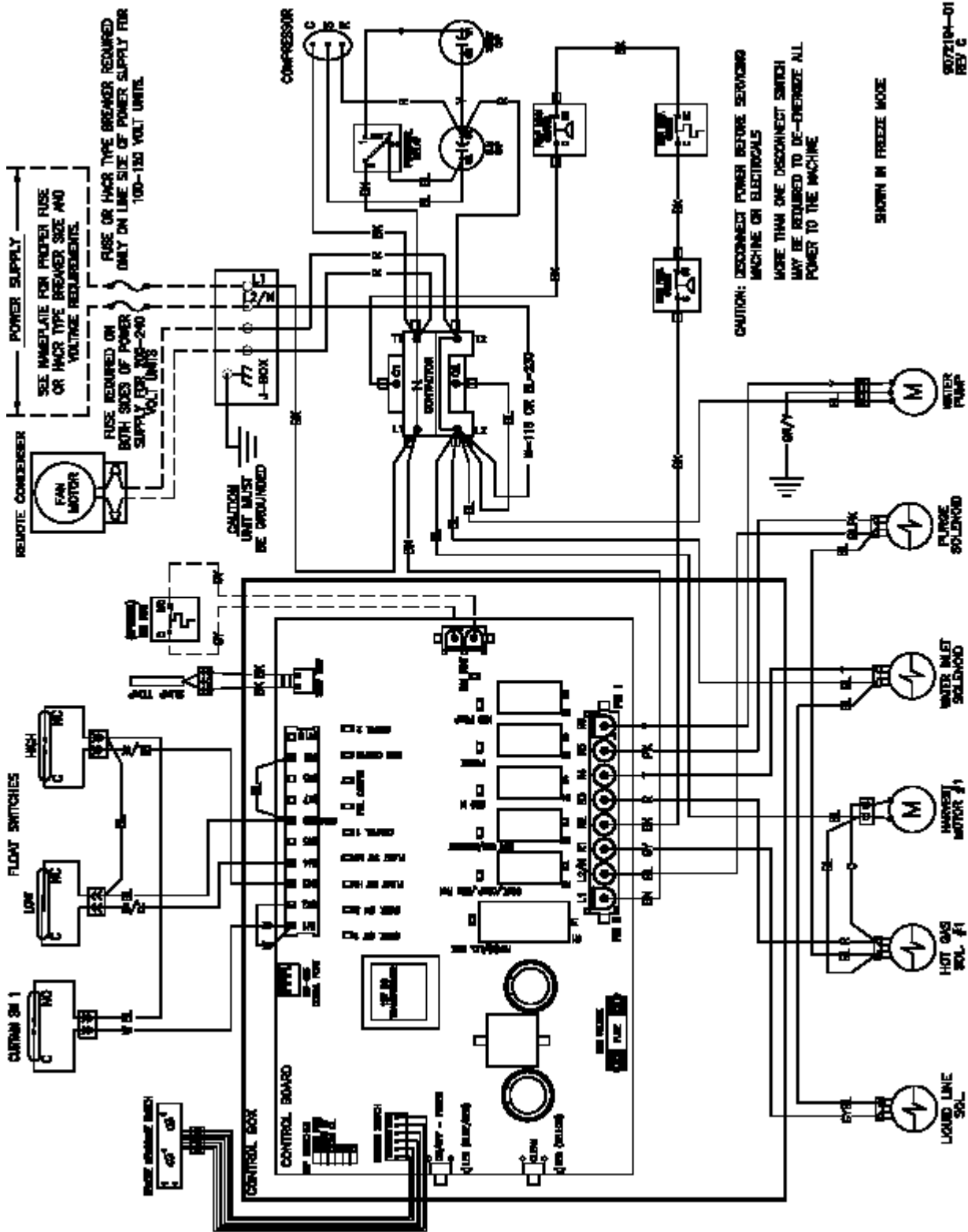

Figure 77.



Cornelius Inc.
www.cornelius.com