

INSTALLATION MANUAL

ICE/BEVERAGE DISPENSER

Model: ED 300 BC

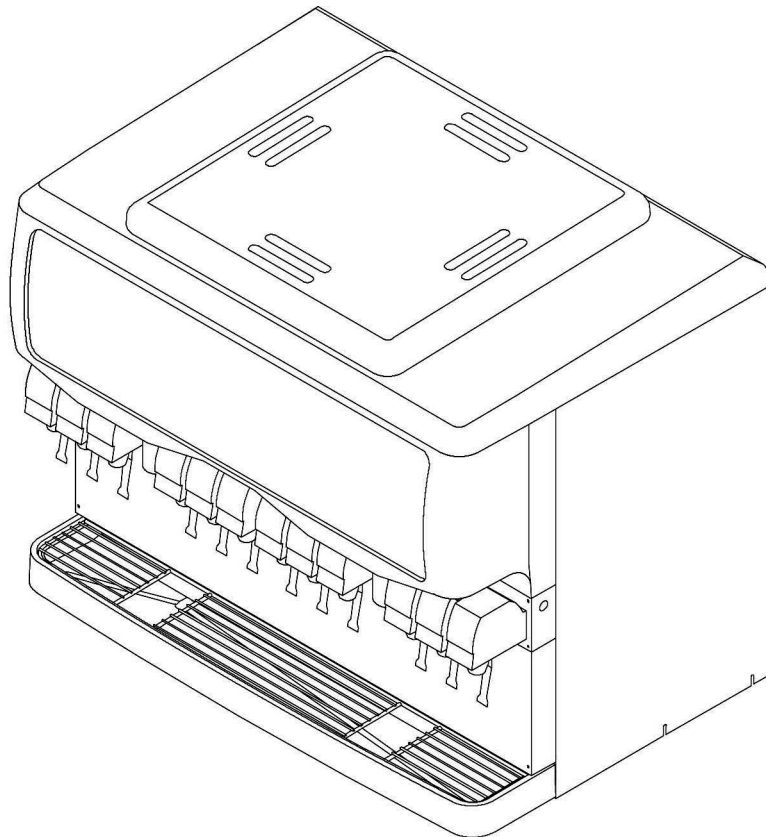

Release Date: March 25, 2004
Publication Number: 92166INS
Revision Date: February 17, 2023
Revision: H



**Marmon Foodservice
Technologies**

A Berkshire Hathaway Company

Visit the Cornelius web site at www.cornelius.com for all your Literature needs.

The products, technical information, and instructions contained in this manual are subject to change without notice. These instructions are not intended to cover all details or variations of the equipment, nor to provide for every possible contingency in the installation, operation or maintenance of this equipment. This manual assumes that the person(s) working on the equipment have been trained and are skilled in working with electrical, plumbing, pneumatic, and mechanical equipment. It is assumed that appropriate safety precautions are taken and that all local safety and construction requirements are being met, in addition to the information contained in this manual.

This Product is warranted only as provided in Cornelius' Commercial Warranty applicable to this Product and is subject to all of the restrictions and limitations contained in the Commercial Warranty.

Cornelius will not be responsible for any repair, replacement or other service required by or loss or damage resulting from any of the following occurrences, including but not limited to, (1) other than normal and proper use and normal service conditions with respect to the Product, (2) improper voltage, (3) inadequate wiring, (4) abuse, (5) accident, (6) alteration, (7) misuse, (8) neglect, (9) unauthorized repair or the failure to utilize suitably qualified and trained persons to perform service and/or repair of the Product, (10) improper cleaning, (11) failure to follow installation, operating, cleaning or maintenance instructions, (12) use of "non-authorized" parts (i.e., parts that are not 100% compatible with the Product) which use voids the entire warranty, (13) Product parts in contact with water or the product dispensed which are adversely impacted by changes in liquid scale or chemical composition.

Contact Information:

To inquire about current revisions of this and other documentation or for assistance with any Cornelius product contact:

www.marmonfoodservice.com

www.cornelius.com

800-238-3600

Trademarks and Copyrights:

This document contains proprietary information and it may not be reproduced in any way without permission from Cornelius.

This document contains the original instructions for the unit described.

MARMON FOODSERVICE TECHNOLOGIES INC

355 Kehoe Blvd

Carol Stream, IL

Tel: + 1 800-238-3600

Printed in U.S.A.

EQUIPMENT REGISTRATION



Thank you for purchasing your equipment from the Marmon Foodservice Technologies family of brands. From technical support to warranty dispatch to replacement parts sales, Marmon Link provides your entire after-sales support for Cornelius, Prince Castle, Silver King, and Angelo Po America equipment.

Registering your equipment will help us keep you up to date on equipment information, preventative maintenance resources, and other topics. Your equipment's warranty will not be affected if you choose to not fill out this form.

To expedite the process, we ask that you have the following:

- The serial numbers of the equipment you purchased.
- The name and email address for a designed store contact.
- The general store information, including address location number.

REGISTER YOUR EQUIPMENT

To Maximize Your Benefits

- Comprehensive after-sales service
- Over the phone technicians
- Quick-ship parts

Complete with:

- Serial Number
- Equipment location details



Your equipment serial number will be validated against our database of existing serial numbers. If you are having difficulties entering a valid number, please contact Marmon Link at **1-866-275-6392**.

TABLE OF CONTENTS

Table of contents	1
Safety Instructions	1
Read and Follow ALL Safety Instructions	1
Safety Overview	1
Recognition	1
Different Types of Alerts	1
Safety Tips	1
Qualified Service Personnel	1
Safety Precautions	2
Shipping And Storage	2
CO2 (Carbon Dioxide) Warning	2
Power Cord	2
Mounting in or on a Counter	2
Noise Level	2
Description	3
Specifications	3
Installation Instructions	4
Adjust Water-to-Syrup Ratio	5
Gate Restrictor plate	5
Drip Tray Drain Assembly	6
Troubleshooting	7
Schematics	9
Flow Diagram (BC Models with Twelve Beverage Faucets)	9
Flow Diagram (B Models with Twelve Beverage Faucets)	10
Wiring Diagram (120 V Unit)	11
Wiring Diagram (220--240 V Unit)	12
Mounting Template	13
Mounting Template (Ice only- B models)	13
Mounting Template (BC models)	13

SAFETY INSTRUCTIONS

READ AND FOLLOW ALL SAFETY INSTRUCTIONS

Safety Overview

- Read and follow **ALL SAFETY INSTRUCTIONS** in this manual and any warning/caution labels on the unit (decals, labels or laminated cards).
- Read and understand ALL applicable OSHA (Occupational Safety and Health Administration) safety regulations before operating this unit.

Recognition



DIFFERENT TYPES OF ALERTS

DANGER:

Indicates an immediate hazardous situation, which if not avoided, **WILL** result in serious injury, death or equipment damage.

WARNING:

Indicates a potentially hazardous situation, which if not avoided, **COULD** result in serious injury, death, or equipment damage.

CAUTION:

Indicates a potentially hazardous situation, which if not avoided, **MAY** result in minor or moderate injury or equipment damage.

SAFETY TIPS

- Carefully read and follow all safety messages in this manual and safety signs on the unit.
- Keep safety signs in good condition and replace missing or damaged items.
- Learn how to operate the unit and how to use the controls properly.
- **Do not** let anyone operate the unit without proper training. This appliance is **not** intended for use by very young children or infirm persons without supervision. Young children should be supervised to ensure that they do not play with the appliance.
- Keep your unit in proper working condition and do not allow unauthorized modifications to the unit.

QUALIFIED SERVICE PERSONNEL

WARNING:

Only trained and certified electrical, plumbing and refrigeration technicians should service this unit. **ALL WIRING AND PLUMBING MUST CONFORM TO NATIONAL AND LOCAL CODES. FAILURE TO COMPLY COULD RESULT IN SERIOUS INJURY, DEATH OR EQUIPMENT DAMAGE.**

SAFETY PRECAUTIONS

This unit has been specifically designed to provide protection against personal injury. To ensure continued protection observe the following:

WARNING:

Disconnect power to the unit before servicing following all lock out/tag out procedures established by the user. Verify all of the power is off to the unit before any work is performed.

Failure to disconnect the power could result in serious injury, death or equipment damage.

CAUTION:

Always be sure to keep area around the unit clean and free of clutter. Failure to keep this area clean may result in injury or equipment damage.

SHIPPING AND STORAGE

CAUTION:

Before shipping, storing, or relocating the unit, the unit must be sanitized and all sanitizing solution must be drained from the system. A freezing ambient environment will cause residual sanitizing solution or water remaining inside the unit to freeze resulting in damage to internal components.

CO₂ (CARBON DIOXIDE) WARNING

DANGER:

CO₂ displaces oxygen. Strict attention **MUST** be observed in the prevention of CO₂ gas leaks in the entire CO₂ and soft drink system. If a CO₂ gas leak is suspected, particularly in a small area, **IMMEDIATELY** ventilate the contaminated area before attempting to repair the leak. Personnel exposed to high concentrations of CO₂ gas experience tremors which are followed rapidly by loss of consciousness and **DEATH**.

Power Cord

If the power cord is damaged, it must be replaced by a special cord available from the manufacturer or its service agent.

Mounting in or on a Counter

WARNING:

When installing the unit in or on a counter top, the counter must be able to support in excess of the total operating unit weight. **Failure To Comply Could Result In Serious Injury, Death Or Equipment Damage.**

NOTE: Many units incorporate the use of additional equipment such as ice makers. When any additional equipment is used you must check with the equipment manufacturer to determine the additional weight the counter will need to support to ensure a safe installation.

Noise Level

This unit emits acoustical noise with an A-weighted sound pressure level no greater than 70dB, as measured in accordance with ED 60335-2-75.



DESCRIPTION

The “ENDURO” series of ice dispensers solves your ice and beverage service needs in a sanitary, space saving, economical way. Designed to be manually filled with ice from any remote ice-making source, these dispensers will dispense cubes (up to 1-1/4 inch in size), cubelets, and hard-chipped or cracked ice. In addition, several flavors of post-mix beverages. “BC” units include beverage faucets and a cold plate and are designed to be supplied direct from syrup tanks and carbonator, with no additional cooling required.

Specifications

Model Descriptions:	ED300 (Ice only) B= (Beverage Faucets) BC= (Faucets and Cold Plate) Z= (No Drip) F= (Flavor Option)
Ice Storage:	300 lbs
Maximum number of Faucets Available	12
Built-in Cold Plate:	Yes, on BC models only
Electrical:	120/1/60Hz, 5.2 Amps Total Unit Draw 220-240/1/50/60 Hz, 2.6 Amps Total Unit Draw
Dimensions:	44-3/8 in. Wide X 31-1/2 in. Deep X 37 in. High Z model = 44-3/8 in. Wide X 23-1/16 in. Deep X 37 in. High

INSTALLATION INSTRUCTIONS

WARNING:

It is the responsibility of the Installer to ensure that the water supply to the dispensing equipment is provided with protection against backflow by an air gap as defined in ANSI/ASME A112. 1.2-1979; or an approved vacuum breaker or other such method as proved effective by test and must comply with all federal state and local codes, failure to comply could result in serious injury, death or damage to the equipment.

Water pipe connections and fixtures directly connected to a potable water supply shall be sized, installed, and maintained according to Federal, State, and Local laws.

1. Locate the dispenser indoors on a level counter top.

A. Leg Option, Kit P/N 08017

NOTE: Before installing legs, the plastic plugs (6) in the base threaded holes must be removed.

Unpack the six (6) legs and install them into the threaded holes provided in the bottom of the unit. The installer must provide flexibility in the product and utility supply to permit shifting the position of the dispenser sufficiently to clean the area beneath it.

B. Counter Mounting

The ice dispenser must be sealed to the counter. The template drawing (see applicable Figure 11 or 12) indicates where openings can be cut in the counter. Locate the desired position for the dispenser, then mark the outline dimensions on the counter using the template drawings. Cut openings in counter.

Apply a continuous bead of *NSF International* (NSF) silastic sealant (Dow 732 or equal) approximately 1/4--inch inside of the unit outline dimensions and around all openings. Then, position the unit on the counter within the outline dimensions. All excess sealant must be wiped away immediately.

2. The beverage tubes, drain tube and power cord are routed through the large opening in the bottom of the unit. See the MOUNTING TEMPLATE (Figure 11 or 12) for locating the required clearance opening in the counter for these utility lines.
3. DRIP TRAY DRAIN ASSEMBLY (see Figure 2): Route the drain tube to an open drain with the end of the tube above the "flood" level of the drain. Use the tubing, fittings, clamps, and insulation provided with the Dispenser to assemble the drain. The completed drain line *must* pitch continuously downward and contain no "traps" or improper drainage will result.
4. Connect the beverage system product tubes as indicated in the Beverage System Schematic. This work should be done by a qualified service person.

NOTE: See applicable Plumbing Diagram (see Figure 3,4,5 or 6) or Decal on the lower front panel of the unit for the location of syrup and water connections.

5. Clean the hopper interior (see CLEANING INSTRUCTIONS in Owner's Manual).

WARNING:

This unit must be grounded to avoid possible fatal electrical shock or serious injury to the operator. The unit power card is equipped with a three prong plug. If a Three-hole (grounded) outlet is not available and use an approved method to ground the unit. Failure to comply could result in serious injury, death or damage to the equipment.

6. Connect the power cord to a 120 volt, 60 cycle, 3-wire grounded receptacle. For 220--240 volt International units, a 3--wire power cord is provided. An adapter plug for the particular country will need to be provided by the Installer.
7. Maximum and minimum ambient temperature rating for correct operation is 40 to 105 F
8. The dispenser is not designed for a wash down environment and must not be placed in an area where a water jet could be used.
9. The unit has to be placed in a horizontal position.
10. If the supply cord is damaged, it must be replaced by the manufacturer, it's service agent or similarly qualified person in order to avoid a hazard.

Adjust Water-to-Syrup Ratio

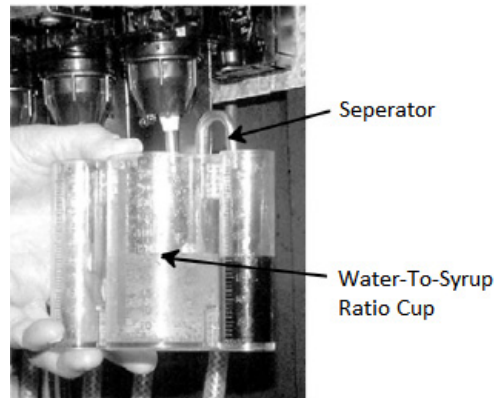

11. Remove valve cover and install syrup separator over the diffuser and through the nozzle.
12. Hold cup under valve and dispenser beverage for a specific time (i.e. 2 seconds)
13. NOTE: water and syrup must be cold before checking ratios.
14. Adjust carbonated water flow to the desired rate (such as 90 to 100 ml (3 to 3.75 oz.) per second). Turn the flow adjuster 1/4 of a turn at a time and recheck the flow. To increase reading turn clockwise.
15. Set a syrup flow adjuster to get the desired ratio.
16. Test the valve and adjust until a consistent ratio is delivered three consecutive times.
17. Repeat procedure for other valves.

Gate Restrictor plate

CAUTION:

Disconnect power to dispenser before installing, removing or adjusting restrictor. see safety section of this manual.

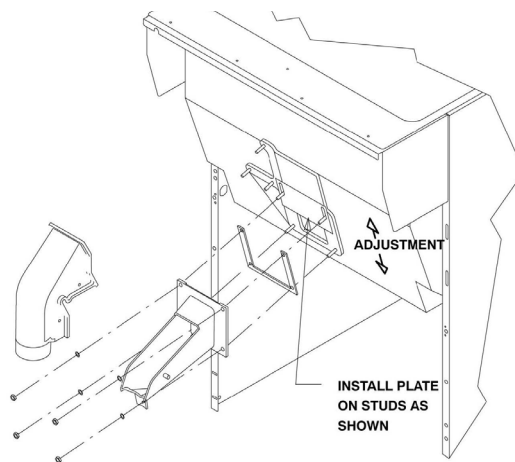

Figure 1 Gate Restrictor Plate

Adjustment

This plate may be adjusted as shown to reduce or increase the dispensing rate of ice, especially desirable when using glasses or other containers with small openings. Adjustment can be made by sliding up or down with nuts loosened, to obtain the desired amount of restriction.

Drip Tray Drain Assembly

Refer Figure 2 to install the drip tray to the drain line.

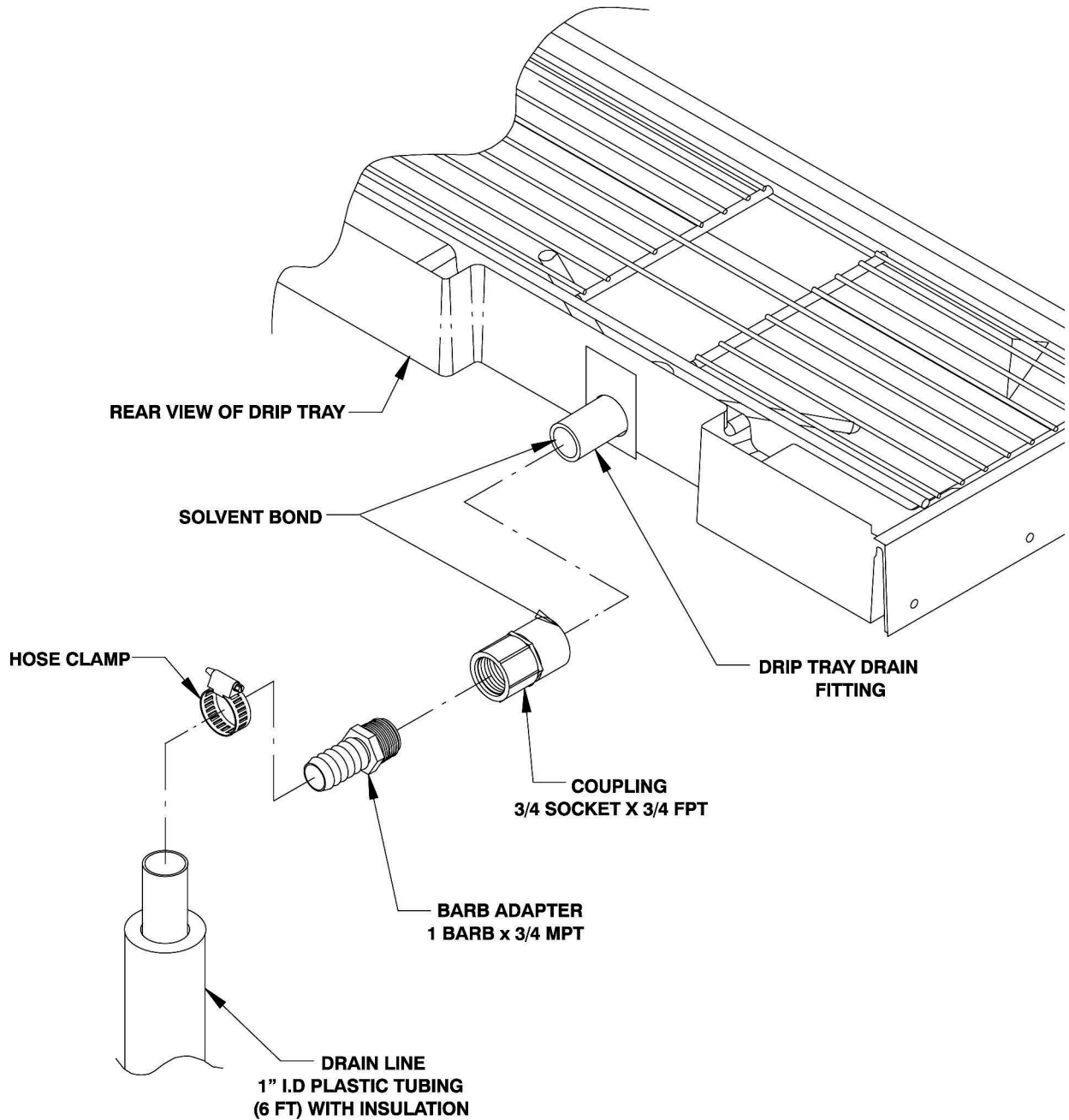

Figure 2 Drip Tray Drain Assembly

TROUBLESHOOTING

IMPORTANT: Only qualified personnel should service internal components or electrical wiring.

WARNING:

If repairs are to be made to a product system, remove quick disconnects from the applicable product tank, then relieve the system pressure before proceeding. If repairs are to be made to the CO₂ system, stop dispensing, shut off the CO₂ supply, then relieve the system pressure before proceeding. If repairs are to be made to the refrigeration system, make sure electrical power is disconnected from the unit.

Should your unit fail to operate properly, check that there is power to the unit and that the hopper contains ice. If the unit does not dispense, check the following chart under the appropriate symptoms to aid in locating the defect.

Trouble	Probable Cause
Blown fuse or circuit breaker.	A. Short circuit in wiring. B. Defective gate solenoid. C. Defective agitator motor.
Gate does not open. agitator does not turn.	A. No power. B. Bent depressor plate (does not actuate switch). C. Defective dispensing switch.
Gate does not open or is sluggish, agitator turns.	A. Defective gate solenoid B. Excessive pressure against gate slide. C. Defective Rectifier.
Ice dispenses continuously.	A. Stuck or bent depressor plate (does not release switch). B. Defective dispensing switch. C. Improper switch installation.
Slushy ice. water in hopper.	A. Blocked drain. B. Unit not level. C. Poor ice quality due to water quality or ice maker problems. D. Improper use of flaked ice.
Beverages do not dispense.	A. No 24 volt power to faucets. B. No CO ₂ pressure.
Beverages too sweet.	A. Carbonator not working. B. No CO ₂ pressure in carbonator. C. Faucet brix requires adjusting.
Beverage not sweet enough	A. Empty syrup tank B. Faucet brix requires adjusting.
Beverages not cold (units with built-in cold plate).	A. Unit standing with no ice in hopper -- no ice in cold plate cabinet.
Flavor dispenses for more than 1 sec	A. Dip switch settings on control board incorrect. B. PC board defective. C. Defective flow control.
Flavor dispenses more than .5 oz	A. Dip switch settings on control board incorrect. B. Flow control incorrectly set. C. PC board defective. D. Defective flow control.



Flavor syrups do not dispense

- A. No 24 volt power to PC board.
 - B. No CO₂ pressure.
 - C. Empty syrup tank.
 - D. Kinked tubing.
 - E. Clogged inner nozzle.
 - F. Defective PC board.
 - G. Defective harness from keypad.
 - H. Defective Flow control.
 - I. Defective solenoid harness.
 - J. Defective keypad.
-

Contact your local syrup or beverage equipment distributor for additional information and troubleshooting of beverage system.

SCHEMATICS

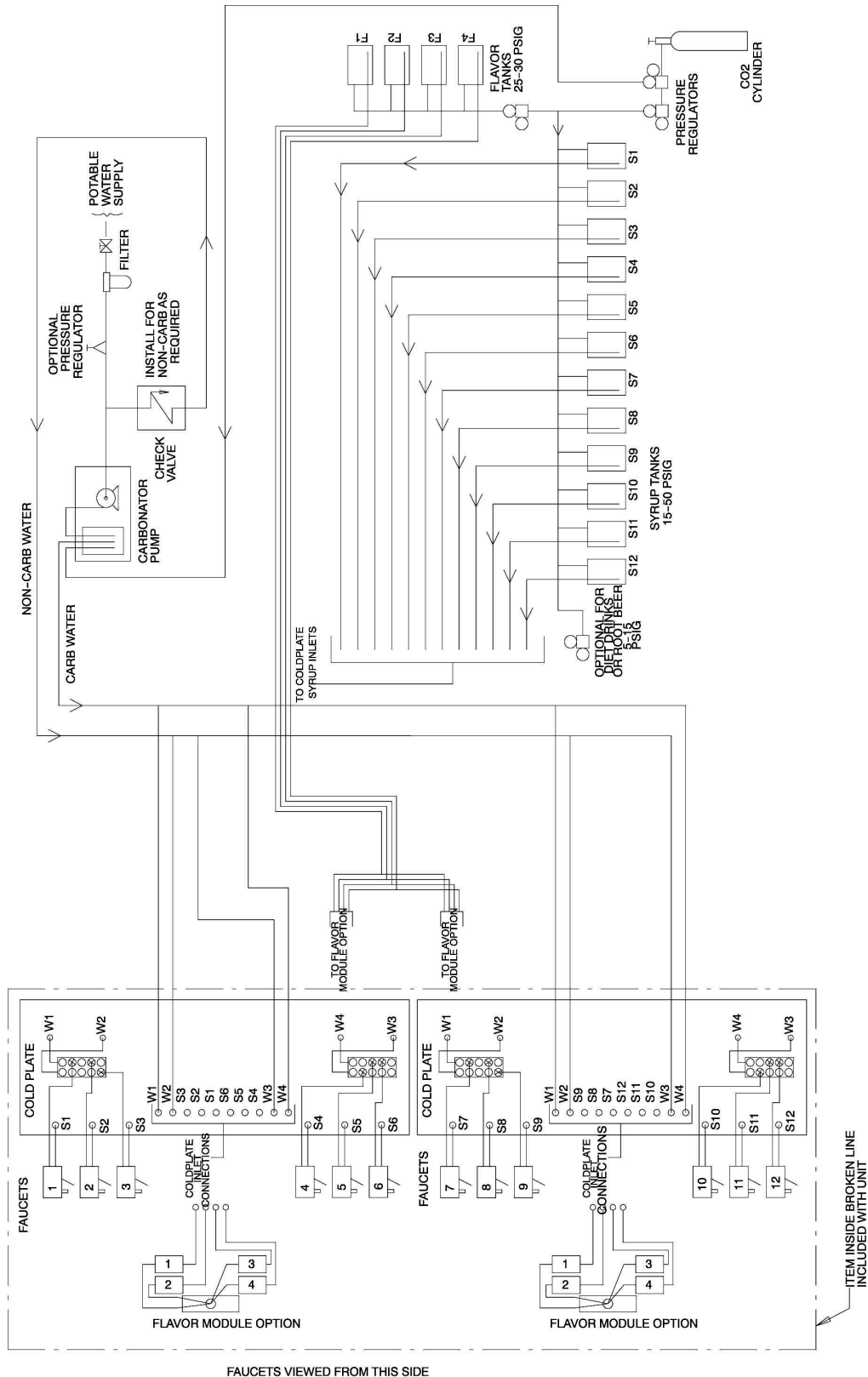

Figure 3 Flow Diagram (BC Models with Twelve Beverage Faucets)

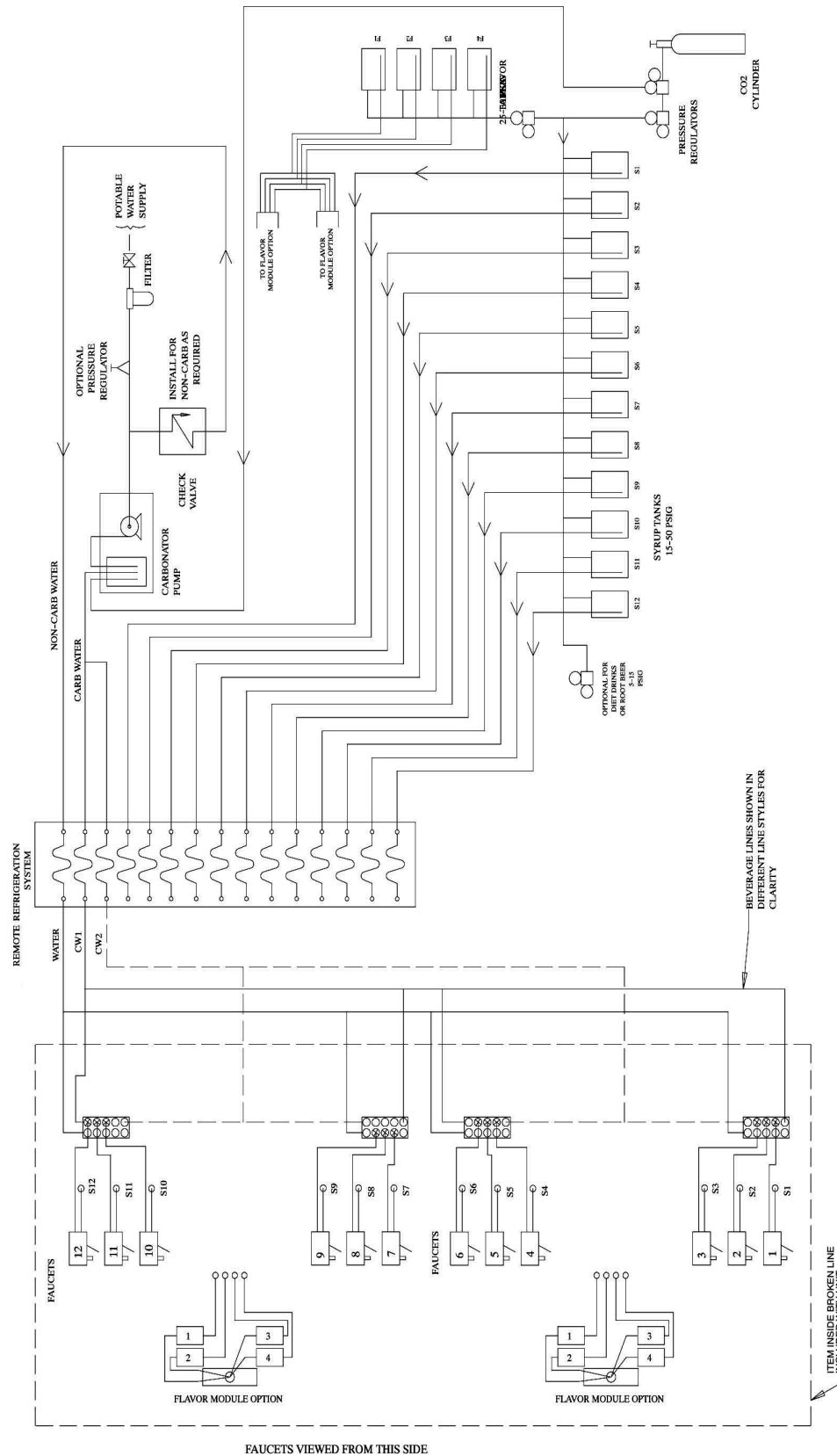

Figure 4 Flow Diagram (B Models with Twelve Beverage Faucets)

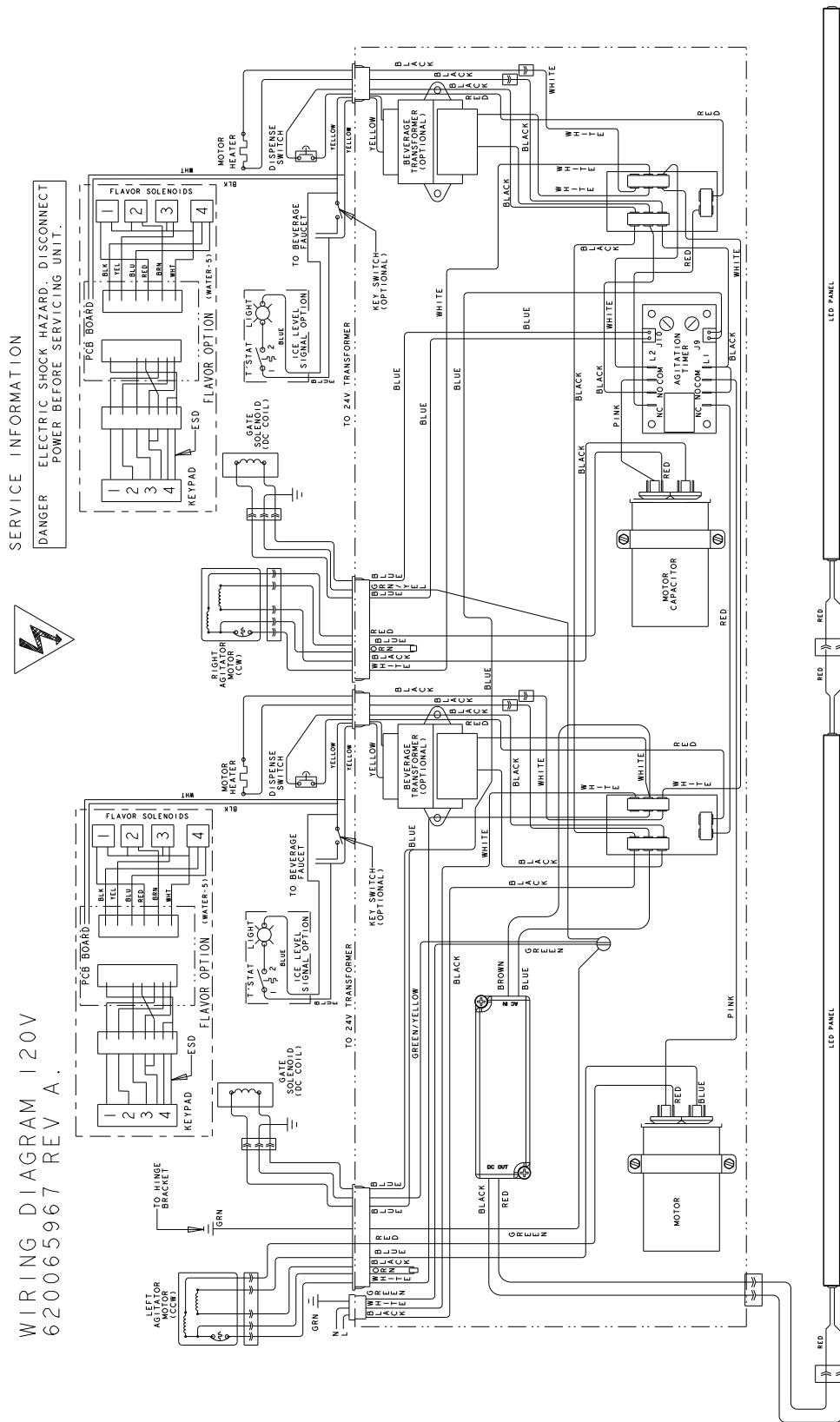

Figure 5 Wiring Diagram (120 V Unit)

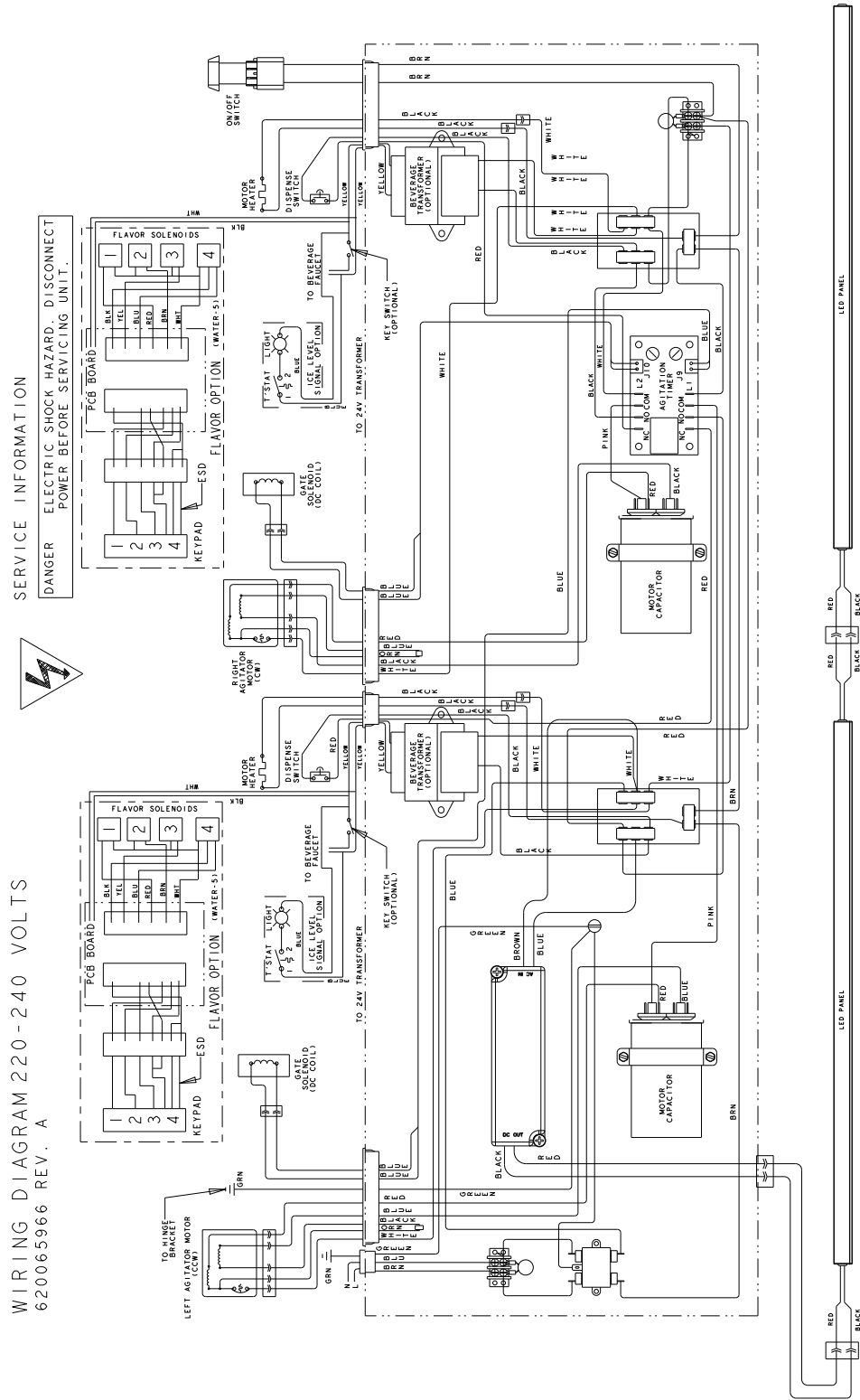

Figure 6 Wiring Diagram (220--240 V Unit)

MOUNTING TEMPLATE

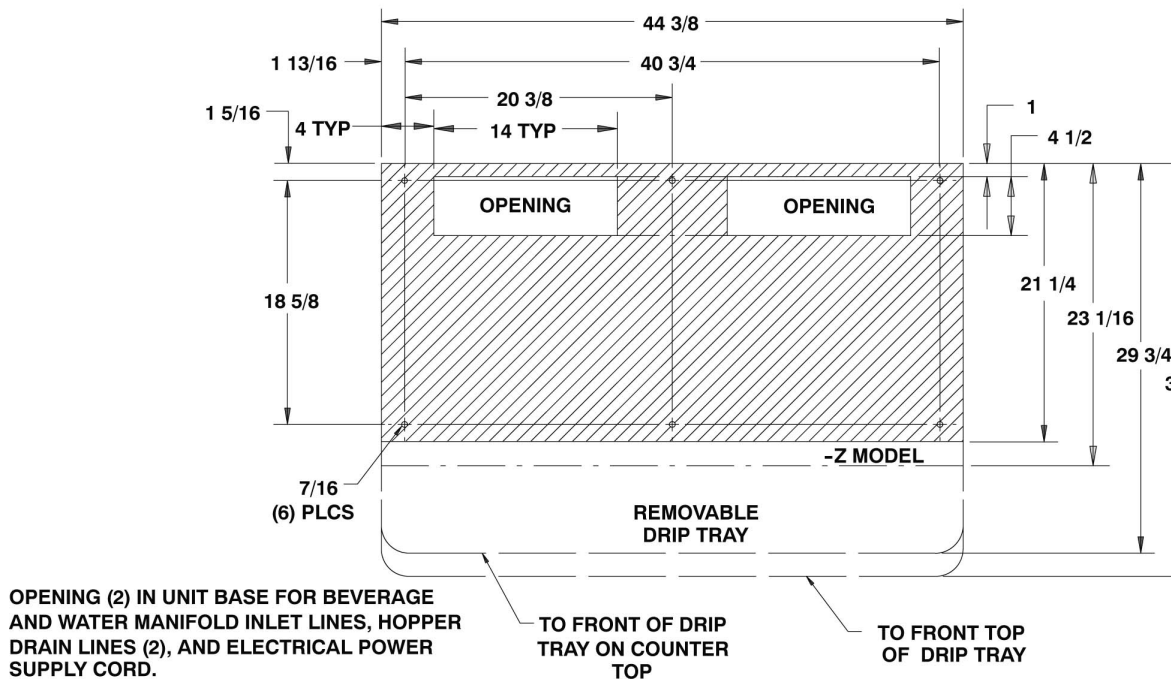

Figure 7 Mounting Template (Ice only- B models)

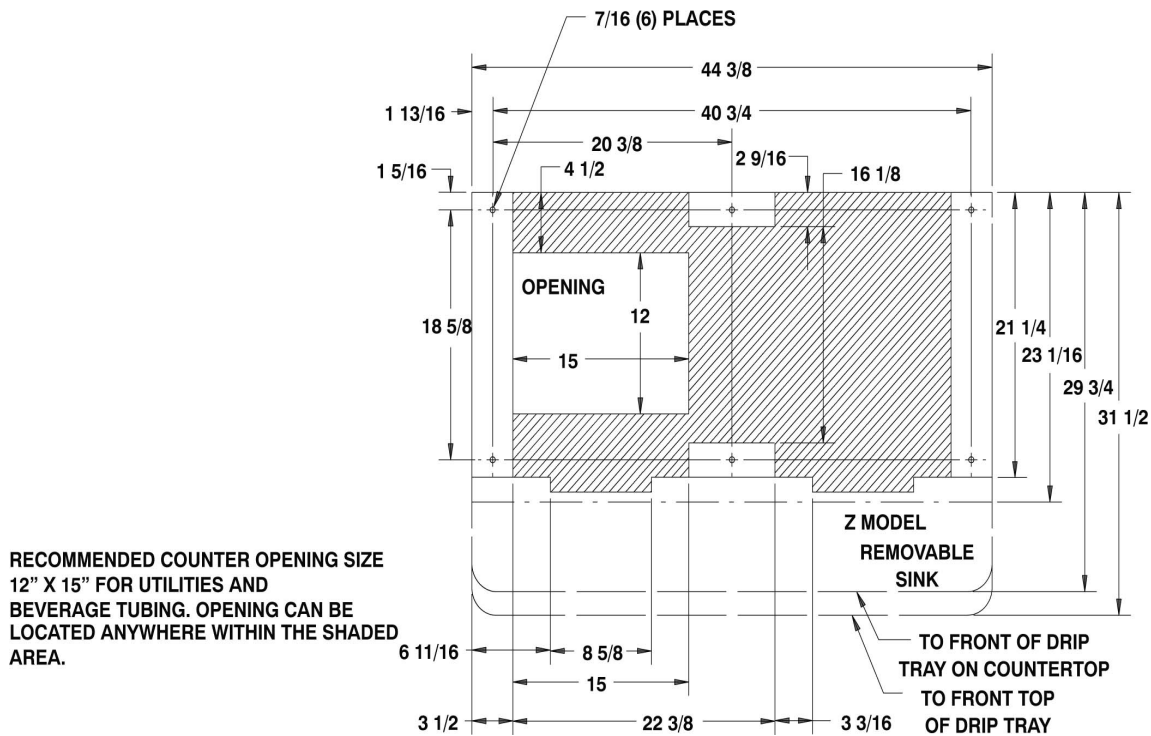

Figure 8 Mounting Template (BC models)

Marmon Foodservice Technologies Inc.
www.marmonfoodservice.com
www.cornelius.com