



---

# **INSTALLATION MANUAL**

## **FCB Pinnacle 2 and 4 Flavor**

**Release Date: November 17, 2005**

**Publication Number: 560007295INS**

**Revision Date: March 24, 2014**

**Revision: G**

Visit the Cornelius web site at [www.cornelius.com](http://www.cornelius.com) for all your Literature needs.

---

The products, technical information, and instructions contained in this manual are subject to change without notice.

These instructions are not intended to cover all details or variations of the equipment, nor to provide for every possible contingency in the installation, operation or maintenance of this equipment. This manual assumes that the person(s) working on the equipment have been trained and are skilled in working with electrical, plumbing, pneumatic, and mechanical equipment. It is assumed that appropriate safety precautions are taken and that all local safety and construction requirements are being met, in addition to the information contained in this manual.

This Product is warranted only as provided in Cornelius' Commercial Warranty applicable to this Product and is subject to all of the restrictions and limitations contained in the Commercial Warranty.

Cornelius will not be responsible for any repair, replacement or other service required by or loss or damage resulting from any of the following occurrences, including but not limited to, (1) other than normal and proper use and normal service conditions with respect to the Product, (2) improper voltage, (3) inadequate wiring, (4) abuse, (5) accident, (6) alteration, (7) misuse, (8) neglect, (9) unauthorized repair or the failure to utilize suitably qualified and trained persons to perform service and/or repair of the Product, (10) improper cleaning, (11) failure to follow installation, operating, cleaning or maintenance instructions, (12) use of "non-authorized" parts (i.e., parts that are not 100% compatible with the Product) which use voids the entire warranty, (13) Product parts in contact with water or the product dispensed which are adversely impacted by changes in liquid scale or chemical composition.

### **Contact Information:**

To inquire about current revisions of this and other documentation or for assistance with any Cornelius product contact:

**[www.cornelius-usa.com](http://www.cornelius-usa.com)**

**800-238-3600**

### **Trademarks and Copyrights:**

This document contains proprietary information and it may not be reproduced in any way without permission from Cornelius.

This document contains the original instructions for the unit described.

CORNELIUS INC  
101 Regency Drive  
Glendale Heights, IL  
Tel: + 1 800-238-3600

Printed in U.S.A.

# SAFETY INSTRUCTIONS

## SAFETY

### WARNING:

Before starting installation, read and understand all safety label and warnings on the machine. Also review and understand all safety instructions in the owners, installation and service manuals.

**Failure to comply could result in serious injury, death or damage to the equipment.**

## QUALIFIED SERVICE PERSONNEL

### WARNING:

Only trained and certified electrical, plumbing and refrigeration technicians should service this unit.

**All wiring and plumbing must conform to national and local codes. Failure to comply could result in serious injury, death or equipment damage.**

## SAFETY PRECAUTIONS

This unit has been specifically designed to provide protection against personal injury. To ensure continued protection observe the following:

### WARNING:

Disconnect power to the unit before servicing. Follow all lock out/tag out procedures established by the user. Verify all power is off to the unit before performing any work.

**Failure to comply could result in serious injury, death or damage to the equipment.**

### CAUTION:

Always be sure to keep area around the unit clean and free of clutter.

**Failure to keep this area clean may result in injury or equipment damage.**

# INSTALLATION INSTRUCTIONS

## INSTALLATION REQUIREMENTS

### Requirements Summary

Environment		Indoor installation only
Temperature		40 to 90°F ambient temperature
CO <sub>2</sub>		60 psi minimum at unit
Syrup		60 psi minimum at pressure switch, .35 ounces per sec. (.17 gpm) at unit
Water		25 psi minimum (flowing), 3.5 ounces per sec./100 gallon per hour minimum (per 2 barrels). Minimum 1/2" ID water inlet recommended
Electrical	60 Hz Unit	208-230 volts, 20 amp, 60 Hz (2 Flavor) 208-230 volts, 40 amp, 60 Hz (4 Flavor)
	50 Hz Unit	230 volts, 15 amp, 50 Hz (2 Flavor)

### Electrical Requirements

Refer to the nameplate to determine the power requirements before connecting electrical power to the unit. All of the power cords shall comply with safety requirements outlined in the EC Standards (EN60335-1 1 Clause 24.1) in countries where CE compliance is required. All cords must be HD 21 or HD 22.

Voltage across contactor terminals L1 and L2, with compressor running, must be within voltage limits described in the Requirement Summary.



**DANGER:**

To avoid possible serious injury or death the ELCB (earth leakage circuit breaker) must be installed in the electrical circuit of all units.



**WARNING:**

To avoid possible electrical shock make sure the unit is properly grounded by connecting the earth ground cable, in the power cord, to any connection in the machine marked with a ground symbol.



**CAUTION:**

The wiring must be properly grounded and connected through a disconnect switch (slow-blow fuse or equivalent HVAC/R circuit breaker - 20 amp for the 2 Flavor model and 40 amp for the 4 Flavor model) for 60Hz units. Refer to the local and national wiring codes for the 50Hz unit. **All wiring must conform to national and local codes.**

### Line Voltage

The recommended line voltages for the Pinnacle unit are as follows:

The unit has a low voltage cut out at 180 VAC and a high voltage cut out at 260 VAC.

Voltage	Corrective Action
Below 180 V	<b>DO NOT</b> connect unit.
180 to 190 VAC	Boost voltage by +32 V.
191 to 208 VAC	Boost voltage by +16 V.
209 to 240 VAC	Use line voltage.
241 to 253 VAC	Reduce voltage by -16 V.
254 to 272 VAC	Reduce voltage by -32 V.
Above 272 VAC	<b>DO NOT</b> connect unit.

## Environmental Requirements

Ambient (room) temperature must not exceed 90° F. Temperatures in excess of 90° F will void the factory warranty and may eventually result in refrigeration system failure. If the unit is powered up while it is over 120° F, the unit will not function. Call Service.

If the inside cabinet temperature is over 120° F, let the temperature cool to 100° F before continuing the install.

### CAUTION:

There must be proper clearance on all sides and on top of the unit to avoid overheating and damaging the unit and voiding the warranty.

### CAUTION:

This unit is designed for indoor installation only (in a non-harsh environment). See the Requirements Summary for this information.

### CAUTION:

The water in the unit will freeze and may damage the unit if the unit is exposed to freezing temperature.

## DELIVERY INSPECTION AND UNPACKING

### Inspection

Inspect the unit for damage or irregularities upon delivery. Immediately report problems to the delivering carrier and file a claim with that carrier.

### Unpacking

1. Remove 4 bolts and strapping from the crate. Remove staples and lift the carton off of the pallet.

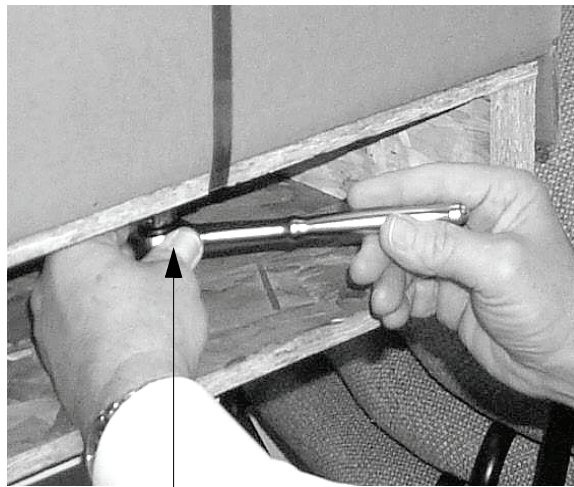

Remove Bolts

Figure 1.

2. Remove packing fillers from top of the unit.
3. Open the packages of loose parts and inspect all of the parts. The Magnet Puller Tool is P/N 560003662 (stored at the inside base of the frame).

## INITIAL INSTALLATION PROCEDURE

**NOTE:** Tubing, hoses, and cabling come from beneath or in back of the unit. Make a hole in the counter or wall to accommodate them or allow for no less than 4 inches of clearance behind the unit and 18 inches above the unit. Ten inches of clearance, behind the unit, is required for filter removal.

### Connect Electrical Power - 50Hz and 60Hz Power

**NOTE:** Refer to the nameplate for power requirements before connecting electrical power to the unit.

1. Switch the power to the unit off or remove the fuse to the electrical power circuit breaker.
2. Remove side panel.
3. Feed the power cord through the strain relief either through the bottom or back of the frame, see Figure 2. and into the power box.

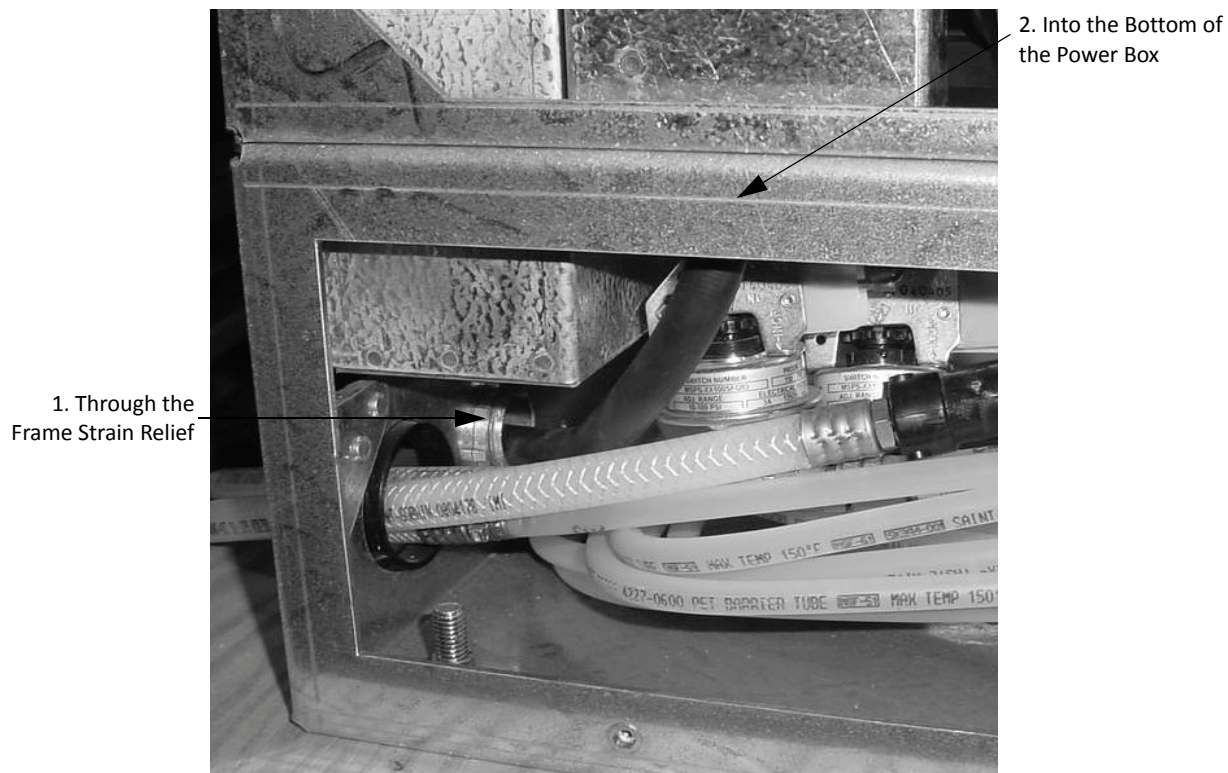
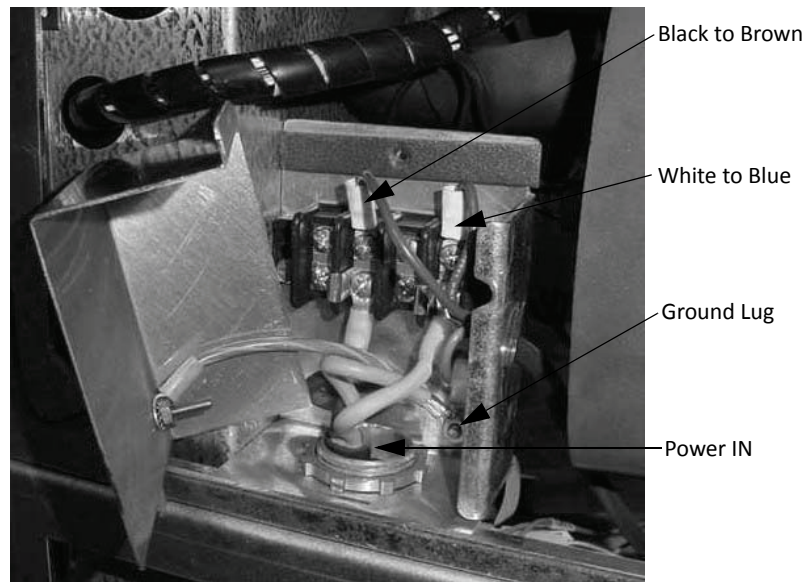

Figure 2.

4. Connect the power cord to the terminal block (Figure 3.)



**Figure 3.**

5. Connect the ground wire to the ground lug (Figure 3.)
6. Pull the slack out of cable and tighten the 2 strain relieves (see Figure 4.) Replace the power box cover. **DO NOT** turn on the power at this time.

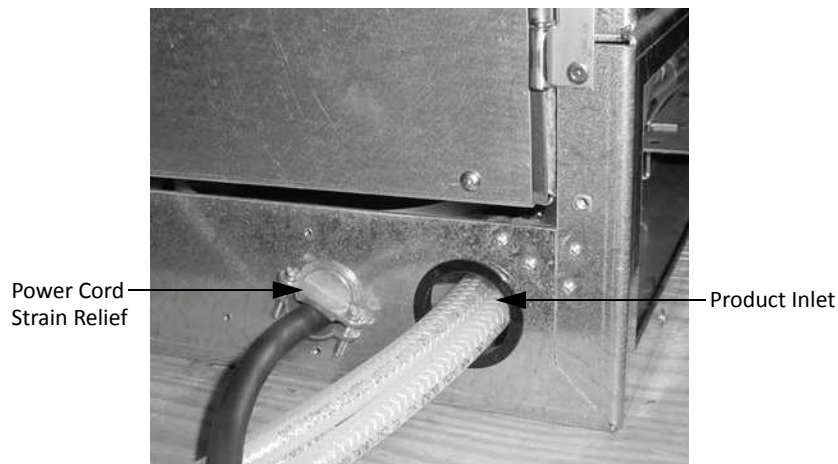

**Figure 4.**

## Testing Power

1. Turn on power to the unit. Watch for the “Initializing - Please Standby” message, displayed for 3-5 seconds, and the merchandiser to light up.
2. Check to make sure the error messages appear.
3. Verify that the Syrup 1 and 2, CO<sub>2</sub>, and Water Sold Out errors exist. Press ERR to see the complete list of errors.
4. If these errors **DO NOT** appear, troubleshooting the Sold Out System is required. Continue if the errors are present.

## CO<sub>2</sub> Installation

### **WARNING:**

Secure the CO<sub>2</sub> cylinder in an upright position with a safety chain to prevent it from falling over and avoid personal injury and property damage.

### **DANGER:**

CO<sub>2</sub> displaces oxygen. Strict attention **MUST** be observed in the prevention of CO<sub>2</sub> gas leaks in the entire CO<sub>2</sub> and soft drink system. If a CO<sub>2</sub> gas leak is suspected, particularly in a small area, **IMMEDIATELY** ventilate the contaminated area before attempting to repair the leak. Personnel exposed to high concentrations of CO<sub>2</sub> gas experience tremors which are followed rapidly by loss of consciousness and **DEATH**.

**NOTE: There are 2 CO<sub>2</sub> delivery systems available: High Pressure Cylinder; Low Pressure Bulk System. High pressure Cylinder requires a Primary Regulator with a minimum inlet pressure of 500 psi. Low Pressure Bulk System requires a Secondary Regulator with a Maximum inlet pressure of 200 psi.**

1. As stated in the Warning, secure the CO<sub>2</sub> cylinder with a chain so it can not fall over.
2. Unscrew the protector cap from the CO<sub>2</sub> cylinder valve. Open the CO<sub>2</sub> cylinder valve momentarily to blow any dirt or dust from outlet fitting before installing the primary CO<sub>2</sub> regulator, then close the valve.
3. Remove the shipping plug from the primary CO<sub>2</sub> regulator assembly coupling nut and make sure the gasket is in place inside the nut. Install the regulator assembly on the CO<sub>2</sub> cylinder so the gages can be easily read, then tighten the coupling.
4. Connect the lines to the CO<sub>2</sub> manifold.

## Connect Syrup and Water Lines

Note the points given below before proceeding:

1. Syrup and CO<sub>2</sub> connections require 3/8" I.D. tubing. Water connections require 1/2" I.D. tubing.
2. All hoses must reach the back of the unit plus an adequate amount of extra tubing to allow the unit to be pulled out for servicing.
3. Size, install, and maintain the water pipe, connections, and fixtures directly connected to a potable water supply in accordance with Federal, State, and Local codes.
4. It is the installer's responsibility to ensure that the potable water supply is equipped with protection against backflow. This protection can be an air gap as defined by ANSI/ASME A112.1.2-1979 or by an approved vacuum breaker or other approved method.
5. If the flowing water pressure at the back of the unit is less than the specified 25 psi and 100 GPH flowrate (per 2 barrels) a water pressure booster is required.
6. It is recommended that a water shutoff valve and water filter be installed in the water supply line.

Use the appropriate fittings and clamps to connect the CO<sub>2</sub>, Syrup, and Water lines to the unit. **Do Not** turn on the water or syrup sources at this time.

## Pressurizing CO<sub>2</sub> System

1. Open the CO<sub>2</sub> cylinder valve slightly to allow lines to slowly fill with gas. When lines are fully pressurized, open the CO<sub>2</sub> cylinder valve all the way until it back-seats itself (this prevents leaks from the valve).
2. Adjust the CO<sub>2</sub> cylinder regulator for the unit to 60 psi at the unit. **Do Not** turn on the syrup CO<sub>2</sub> regulator at this time.
3. Adjust the Blendonator tank secondary CO<sub>2</sub> regulators (see Figure 5.), located inside the unit, to between 22 – 28 psi (the regulator is factory set to 23 psi). Open the Freeze Cylinder Shutoff Valves (see Figure 5.), valve lever parallel to valve body (open position). The CO<sub>2</sub> error on the display will automatically reset itself.

**NOTE:** In most applications, setting the CO2 regulator between 26-28 psi will result in undesirable, excessive overrun.

- Bleed the air from both the Blendonator relief valves and the face plate relief valves for 30 seconds each.

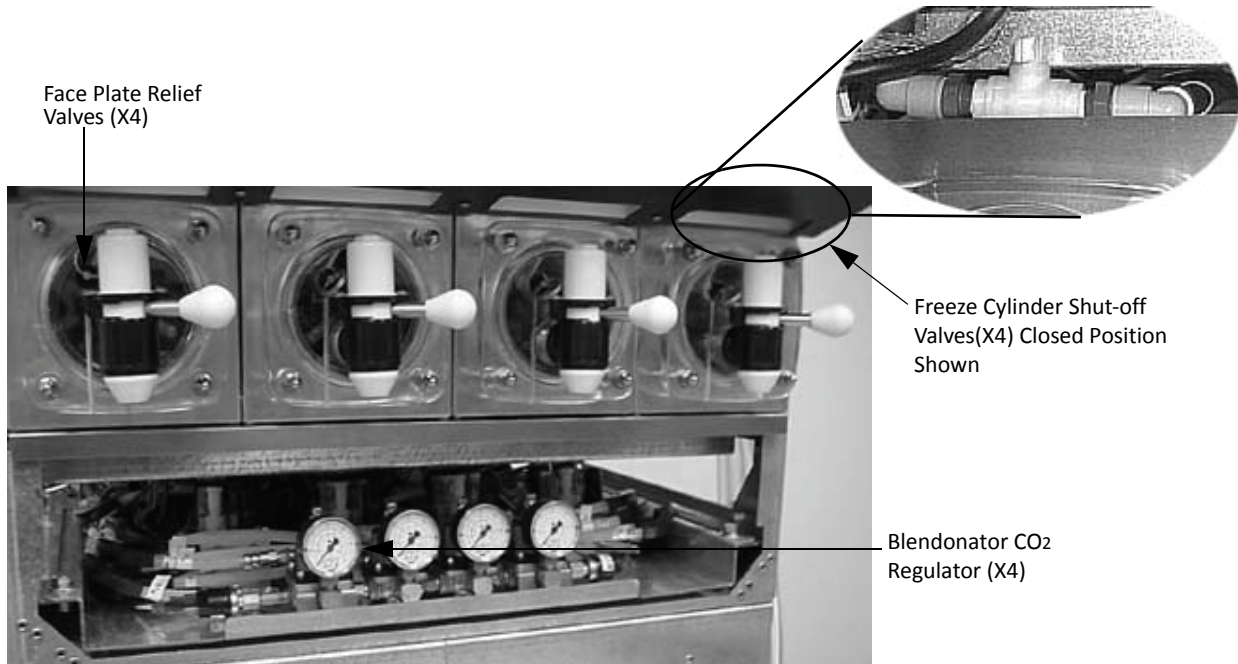

**Figure 5.**

- Check for gas leaks by turning off the CO2 cylinder or bulk CO2 tank valve. Wait at least 3 minutes and check the CO2 cylinder gauge to see if the pressure has dropped.

## Pressurizing Syrup System

- Adjust the CO2 regulator for the syrup BIB pumps, so there is 60 psi syrup pressure at the unit.
- Check for syrup leaks.
- The syrup error on the display will automatically reset itself.

## Fill Water Bath

**NOTE:** Filling both water baths at once, on the 4 Flavor unit, may cause a H<sub>2</sub>O Error.

- Make sure the Water Bath Drain Line is plugged.
- Turn ON the water supply to the unit.
- Remove the top cover and open the water bath fill valve (Figure 6.) and fill the water bath just to the top of the product cooling coils (Figure 7.)

**NOTE:** If ice bath overfills, water will run out the overflow tube in the front of the unit.

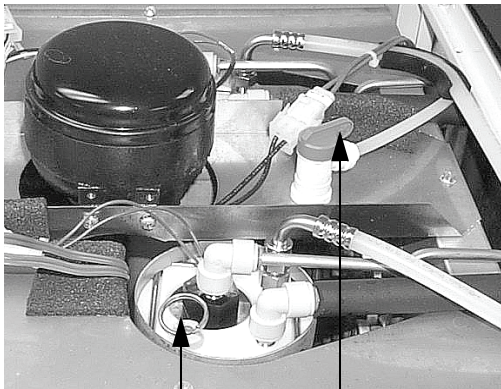

Blendonator Relief Valve Water Bath Fill Valve

**Figure 6.**

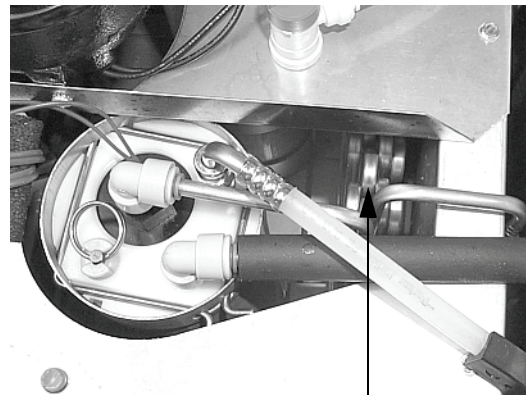

Top of Product Cooling Coils

**Figure 7.**

4. Replace the top cover.

## Power Unit ON

1. Make sure the freeze cylinder shutoff valves are OFF (valve handles perpendicular to valve body, see Figure 5.)

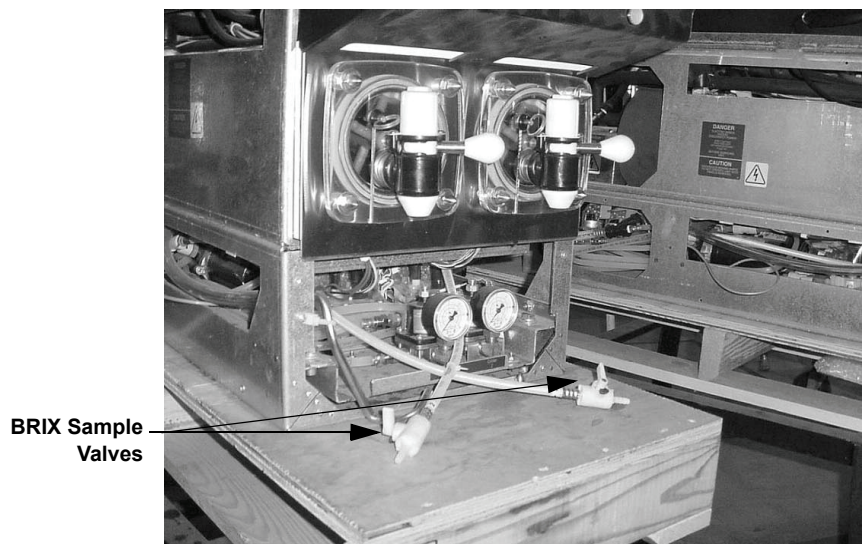

BRIX Sample Valves

**Figure 8.**

2. Turn the power to the unit ON. Watch for the “Initializing - Please Standby” message, displayed for 3-5 seconds. Check to see if there are CO2, water, or syrup error messages.
3. Install back access panel and side panels. Push the unit into place.
4. Ice bank refrigeration will start.
5. Turn on the Blendonators by going into menu 14 and turning both to ON.
6. The product delivery pumps will now turn on and fill the Blendonator tanks. Continue by Brixing the unit.

## Adjust Water-To-Syrup Ratio (BRIX)

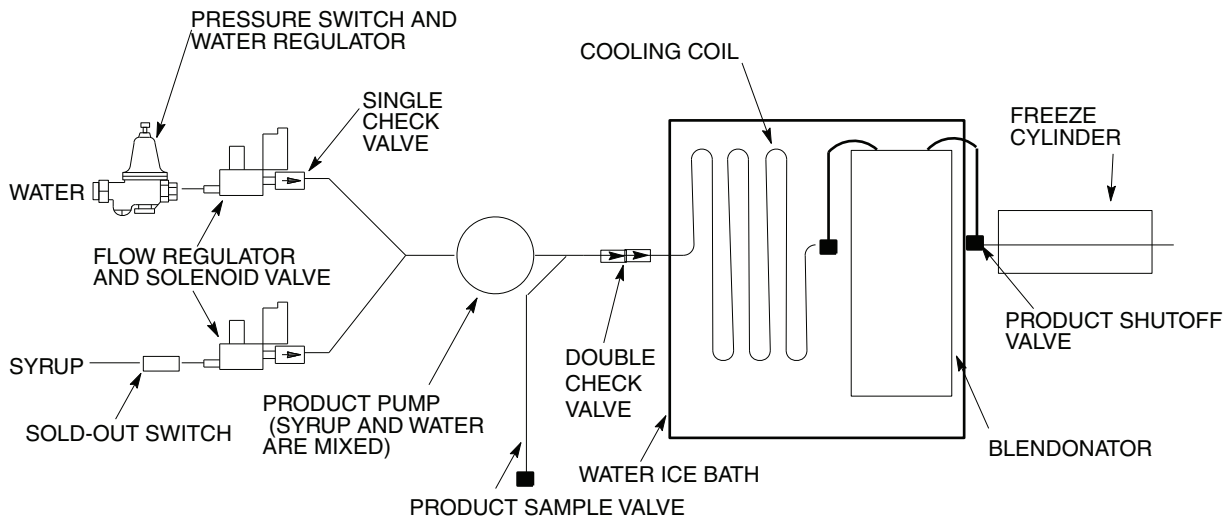

**Figure 9.**

1. Make sure the status of all cylinders is OFF on the display.
2. Turn product supply valve to the 90° (OFF) position for the barrel you are using. It is recommended to close both valves to be sure the correct valve is chosen.
3. Press MENU. Then press UP repeatedly until BRIX is displayed. Press GO and select cylinder you wish to Brix.

**NOTE: Pressing CANCEL will stop the process.**

4. Locate the appropriate (correct barrel) sample tube and hold a cup under it.

**NOTE: If Product Sample Valve is located in a different position than Figure 9. See the schematics in Appendix B for the two alternate constructions (section 1 and 2) and their respective Brixing instructions.**

5. Open the valve at the end of the sample tube. Press GO and wait 3-5 seconds. The product pump will pump product for approximately 3 seconds. After sample is dispensed press Go twice more to dispense product two more times. Discard these first three samples.
6. Press GO again. Collect sample from cup and close valve at end of sample tube. Place adequate amount on refractometer and read Brix. A target Brix reading of 13.0 ( $\pm 1.0$ ) is normally desired for sugar-based syrups. Lower values for some diet syrups can be specified. Check with the syrup manufacturer if you are not sure.
7. If reading is out of specification the syrup level needs to be adjusted. **Never** change the Water Flow Control setting to adjust Brix (Figure 10.)

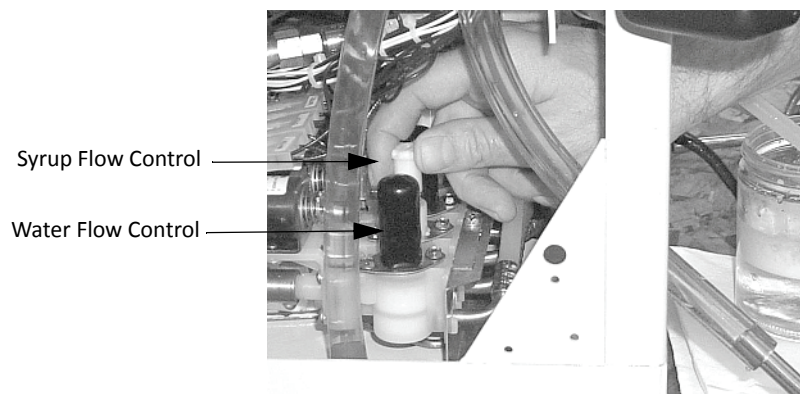

**Figure 10.**



8. To increase Brix reading, turn syrup regulator clockwise. Turn counter-clockwise to decrease Brix. Adjust flow control in no more than ½-turn increments. Repeat steps 4 through 6 for each adjustment until desired Brix setting is achieved.
9. Once the Brix is set, route the product sample valve back into the unit. **DO NOT** fill the barrel with product until the water bath has cooled to 32°F or product will not be properly carbonated. Once the water bath is 32°F or cooler, fill the barrel by opening up the product shut-off valve (see Figure 5.)
10. After finishing step 9 for first barrel, repeat steps 1 through 9 for next barrel.

**NOTE: If Brix percent cannot be set in step 8, check the water flow rate. To do this verify flow in cup is at least 6.3 to 6.9 oz. (186 to 204 ml) in 3 seconds.**

## Setting Up Control Panel

Refer to the Control Panel section in the Pinnacle Service Manual on [www.cornelius.com](http://www.cornelius.com) for detailed explanation of the following procedures.

- Set the Options.
- Set the Clock.
- Set the Sleep and Wake Up.
- Set the Defrost.
- Set the Viscosity.

## Starting Unit

**NOTE: Make sure that the side, back, and top panels are in place.**

1. From the Barrel Status menu press ON and wait 10-15 minutes before serving product.
2. Check to see that the product in the freeze cylinder and the ice bank in the water bath have frozen properly.

**NOTE: The water bath may take 1 to 1-1/2 hours to build an Ice Bank.**

## INSTALLING DRIP TRAY

### Counter Top

1. Attach the Drip Tray Extension Bracket to the Frame with two (2) 1/2" 8-32 screws.

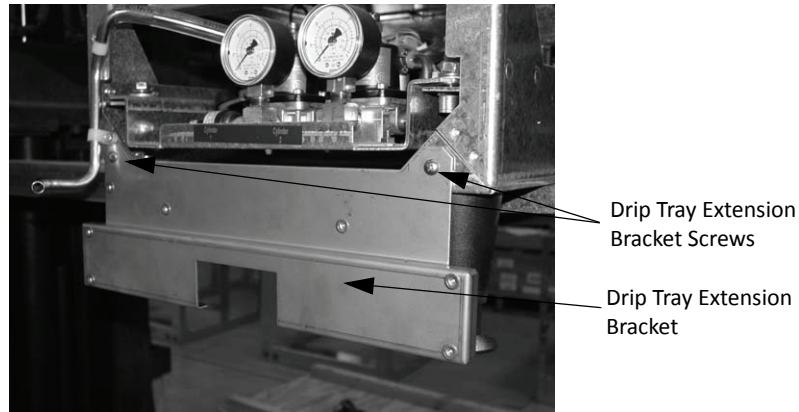

**Figure 11.**

2. Attach the Over Flow Drain Tube to the Frame and Drip Tray Extension Bracket, as shown, with the two (2) 3/8" nylon clamps and two (2) 1/2" 8-32 screws.

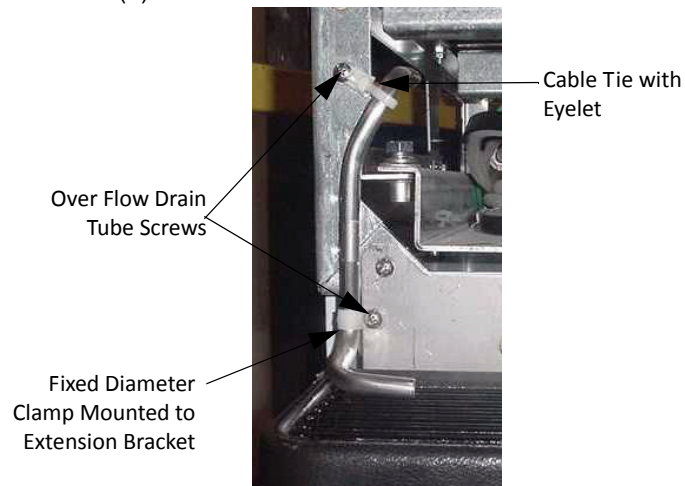

**Figure 12.**

3. Attach the 2 Brackets to the Drip Tray Extension Bracket using two (2) 1/2" 8-32 screws for each.

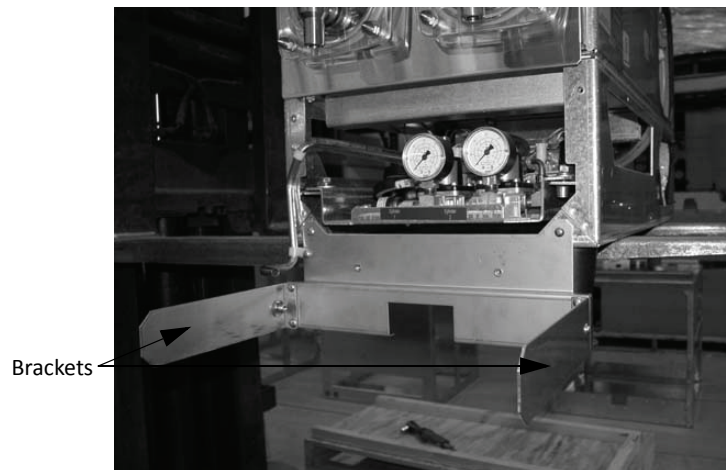

**Figure 13.**

4. Slide the Drip Tray on to the Brackets allowing the catch bullets on the Drip Tray Brackets to interface with the detents on the Drip Tray Frame.
5. Add the 2 Spacers to the rear side of the Splash Panel before attaching it to the Frame.

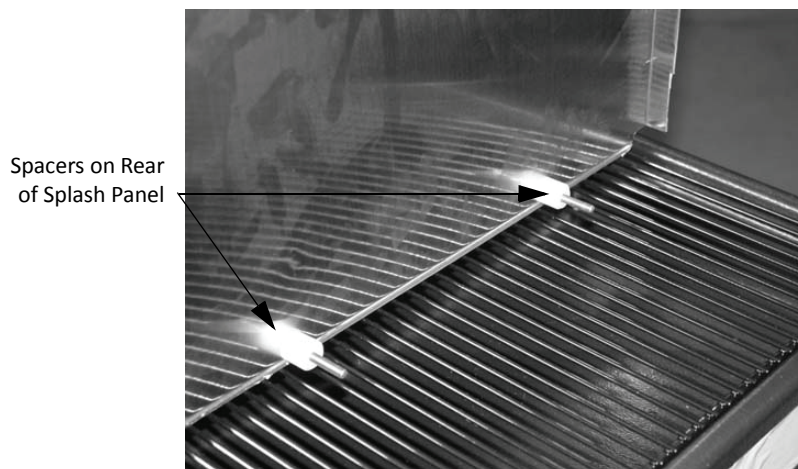

**Figure 14.**

6. Secure the Splash Panel to the Frame using four (4) 1-1/4" 8-32 screws.



**Figure 15.**

## Cart Mount

1. Attach the Over Flow Drain Tube to the Frame and Cart, as shown, with two (2) nylon clamps and two (2) 1/2" 8-32 screws.

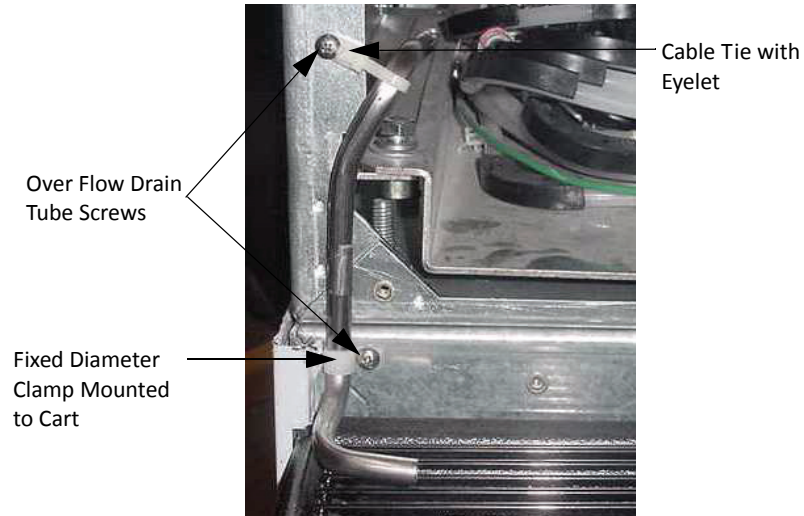

**Figure 16.**

2. Attach the 2 Brackets to the Frame using two (2) 1/2" 8-32 screws for each.

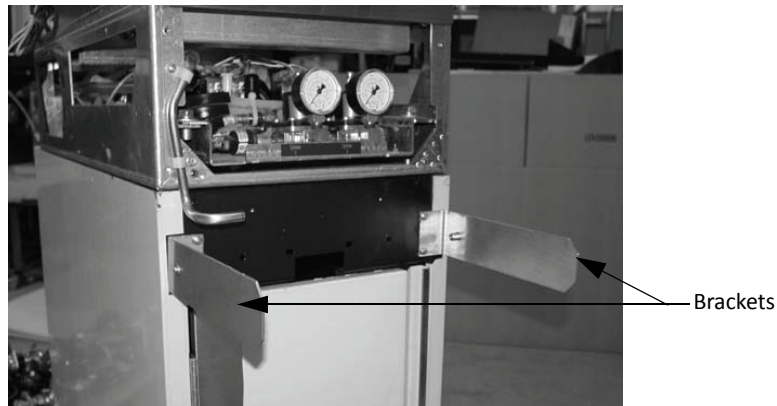

**Figure 17.**

3. Slide the Drip Tray on to the Brackets (allowing the catch bullets on the Drip Tray Brackets to interface with the detents on the Drip Tray Frame).
4. Add the 2 Spacers to the rear side of the Splash Panel before attaching it to the frame (Figure 14.)
5. Secure the Splash Panel to the Frame using four (4) 1-1/4" 8-32 screws.

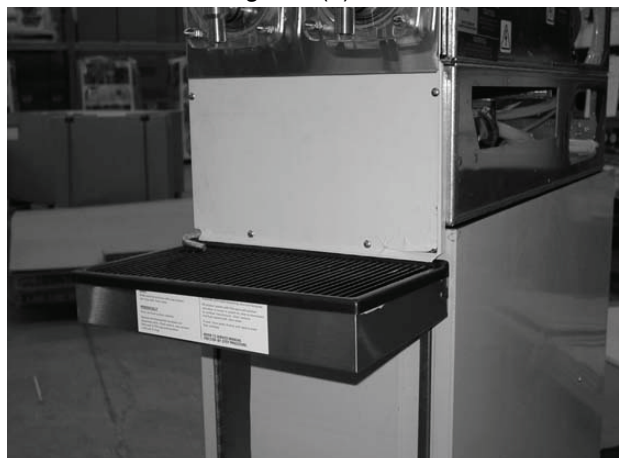

**Figure 18.**

# APPENDIX A - REMOTE CONDENSER

## INSTALLATION INSTRUCTIONS

### Condensing Unit (P/N 631700512)

**NOTE: The condensing unit is sealed and pressurized and care must be taken during installation to prevent injury!**

When determining the proper location for the condensing unit, remember that heat is rejected from the unit during normal operation. The unit should be placed where this heat does not affect nearby objects. Minimize the elevation of the unit (a maximum elevation of 20 feet above the FCB machine is recommended). Avoid locating the condensing unit at an elevation below the FCB machine. This is especially important during winter. Locate the condensing unit such that airflow through the condenser is not restricted. Interference from nearby objects must not impede the performance of the unit. Mount the condensing unit securely. Conform to electrical codes when wiring the unit.

1. Follow the standard installation instructions supplied with Pinnacle. **DO NOT connect Pinnacle into the power source until the remote condenser and line set installation is complete.**
2. Assembly of remote condenser:
  - A. Connect legs to condenser cabinet as shown in Figure 19. and Figure 20.

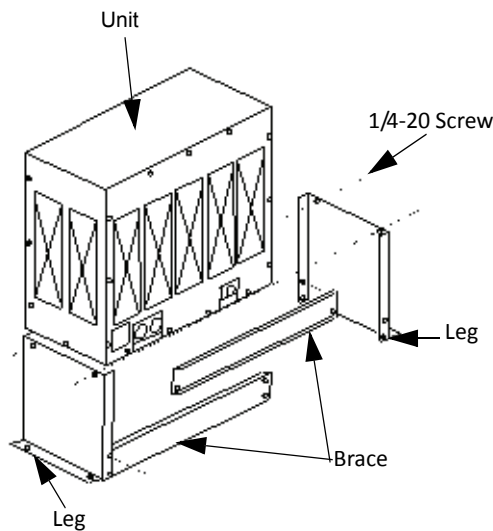

**Figure 19.**

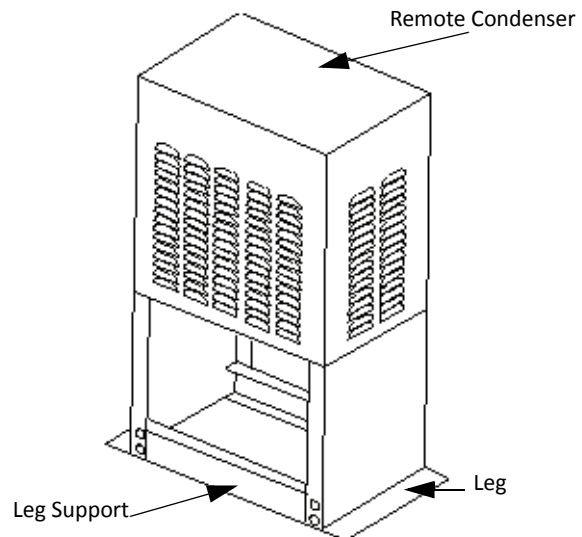

**Figure 20.**

- B. Locate the remote condenser in a well-ventilated area on the roof away from other refrigeration equipment's condenser discharge air flow.
  - C. Use the mounting holes provided to secure the remote condenser to the roof. Seal over heads of bolts or fasteners with tar or pitch to prevent entrance of moisture.
3. Remote condenser electrical installation:
  - A. Connect remote condenser to a power source (208/230VAC, 60 HZ) separate from the Pinnacle. An external disconnect switch must be used.
  - B. Make sure the electrical connections follow all local and national codes.
  - C. Never wire condenser into Pinnacle section. The condenser is an independent electrical connection.
  - D. Fan motor will not start until pressure rises to 275 PSIG closing the fan cycling switch.

## Line Set (P/N 561441253)

**NOTE: The line set is sealed and pressurized and care must be taken during installation to prevent injury! The line set contains approximately 2 ounces of R-404a (HP62).**

Uncoil the line set only as necessary while routing. If equipped, make sure the flexible end of the set is located indoors at the machine and not at the condensing unit. Keep the lines as straight as possible while routing to avoid creating unnecessary traps. Bending the lines should be done carefully to prevent kinks. Coil excess line should be indoors if possible. Minimize the number of coils, and lay the coils horizontally if possible.

**NOTE: Installing an Cornelius remote Pinnacle with a remote condenser and line set other than an Cornelius may void the Pinnacle warranty.**

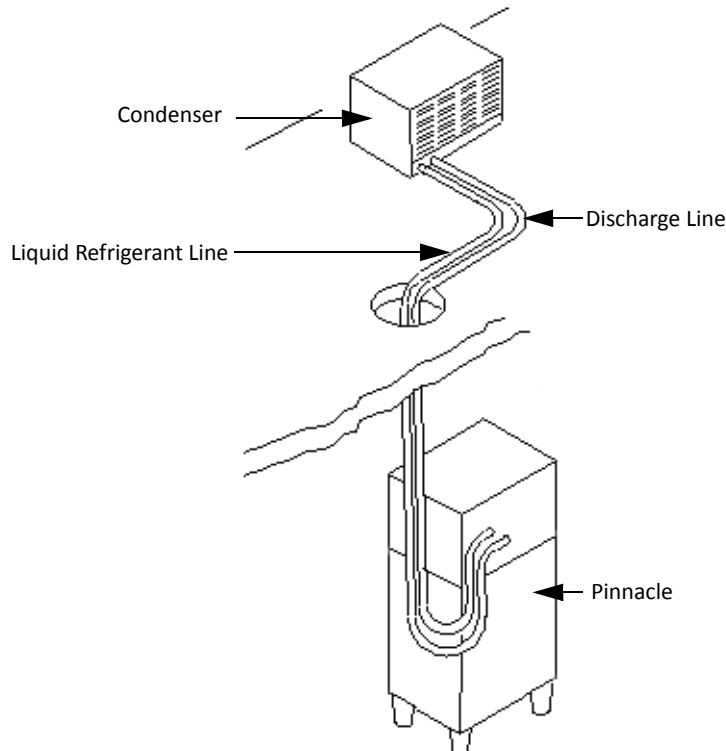

Figure 21.

## Making Connections

Take the following steps when making connections. Note that disconnecting the couplings after installation will result in refrigerant leakage.

1. Remove protector caps and plugs.
2. If necessary, carefully wipe coupling seats and threaded surfaces with a clean cloth to prevent the inclusion of dirt or any foreign material in the system.
3. Lubricate male half diaphragm and synthetic rubber seal with refrigerant oil. Thread coupling halves together by hand to ensure proper mating of threads. Use proper size wrenches (on coupling body hex and on union nut) and tighten until coupling bodies "bottom" or a definite resistance is felt.
4. Using a marker or ink pen, mark a line lengthwise from the coupling union nut to the bulkhead. Then tighten an additional  $\frac{1}{4}$  turn; the misalignment of the line will show the amount the coupling has been tightened. This final  $\frac{1}{4}$  turn is necessary to ensure the formation of a leak proof joint. If a torque wrench is used, torque the "-6" coupling size to 10-12 ft. lbs. and the "-11" coupling size to 35-45 ft. lbs.
5. Leak check all connections.

# APPENDIX B - HISTORIC BRIX PROCEDURES

NOTE: See page 9, step 4 to determine if Appendix B Section 1 or 2 applies to the unit.

## SECTION 1: 3-WAY VALVE BRIXING PROCEDURE

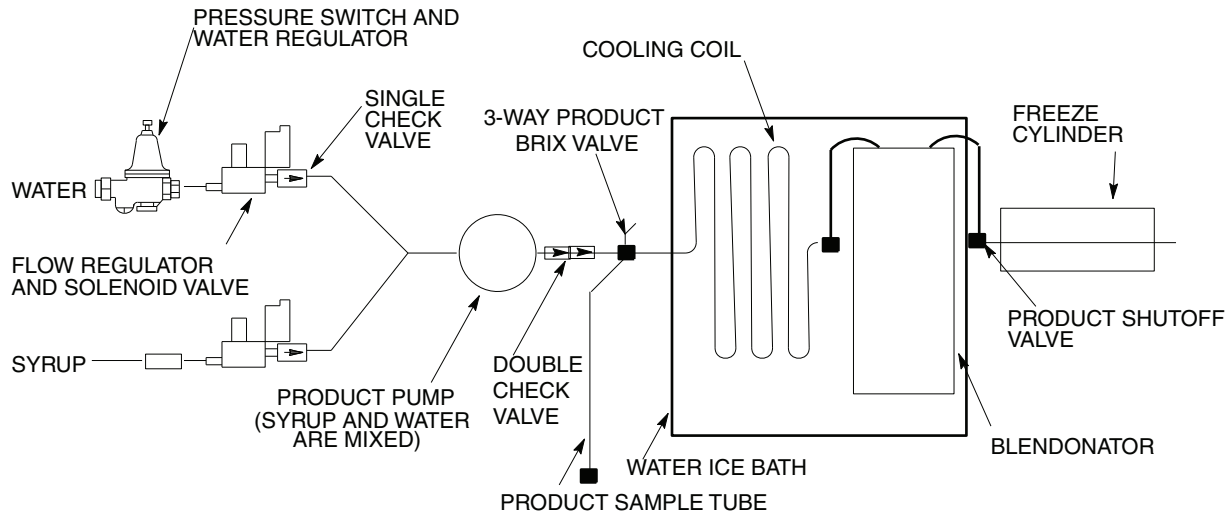

Figure 22.

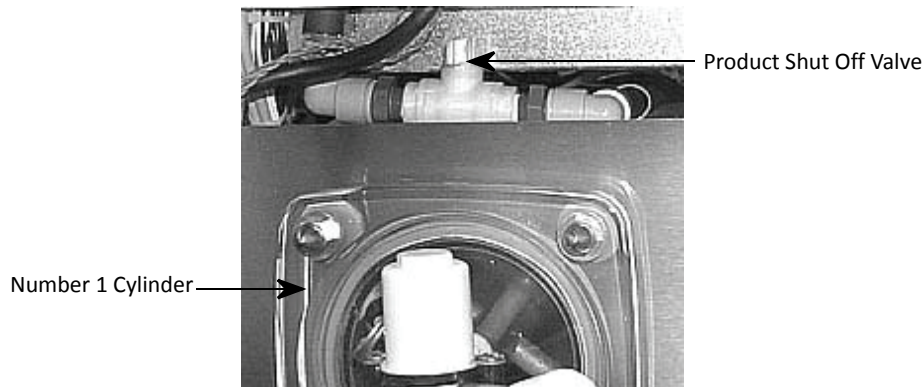

Figure 23.

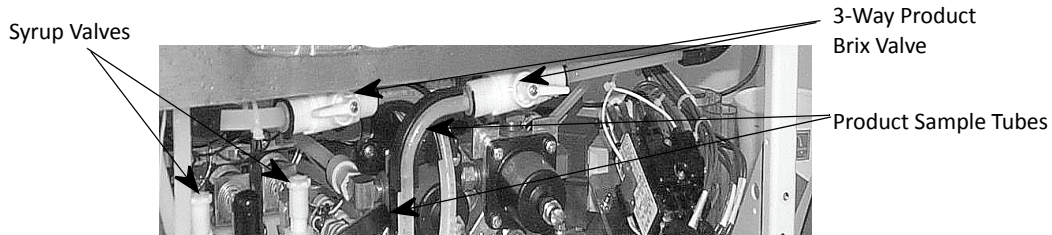
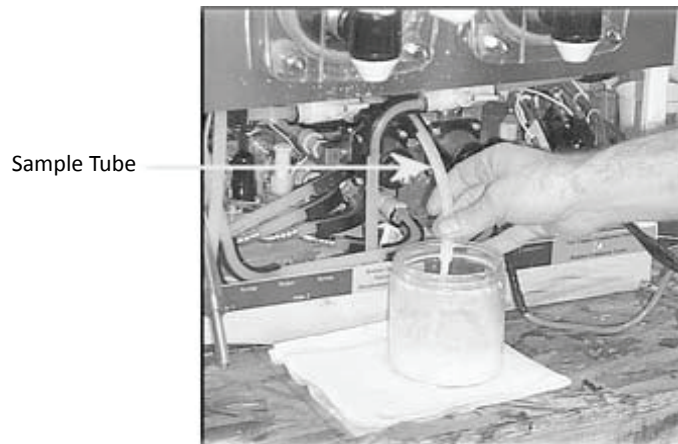

Figure 24.

1. Make sure the status of all cylinders is OFF.
2. Press MENU, press UP until BRIX is selected, press GO, select cylinder to be BRIXed.

NOTE: Pressing CANCEL will stop the process.

3. Turn three-way product valve to BRIX position. Hold a 12 ounce cup under the appropriate sample tube.

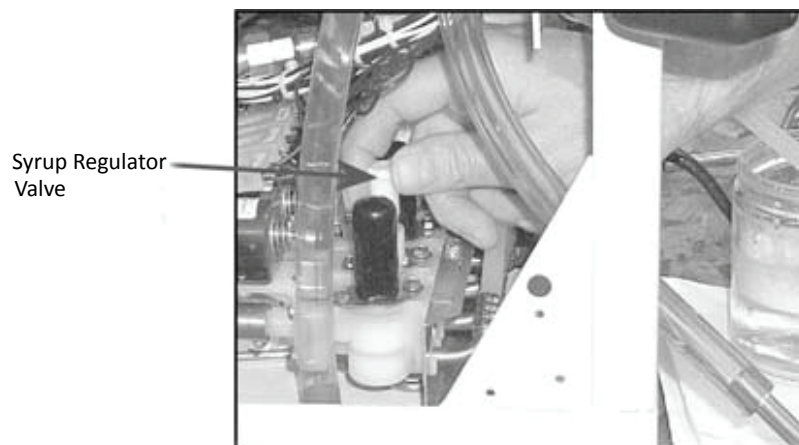

**Figure 25.**

4. Press GO and wait 3-5 seconds. The unit will dispense product for 3 seconds. Discard this first sample.
5. Hold cup under the tube again and press GO.
6. Put sample on refractometer and read BRIX.

**NOTE: Temperature compensated hand-type refractometers (P/N 511004000) are available from Cornelius.**

7. Adjust syrup regulator to get a BRIX reading of  $13 \pm 1$ . To increase reading, turn syrup regulator clockwise.



**Figure 26.**

8. After BRIX is adjusted, turn 3-way product valve to blendonator position.
9. Repeat procedure for additional freeze cylinders.
10. Turn the freeze cylinder shutoff valves to the ON position. Press MENU, press UP until blendonator is selected, press GO, select the desired cylinder, press ON.

11. When the cylinders have stopped filling pull the faceplate relief valves until product comes out. **DO NOT** bleed air too fast or product will foam in the freeze cylinders.

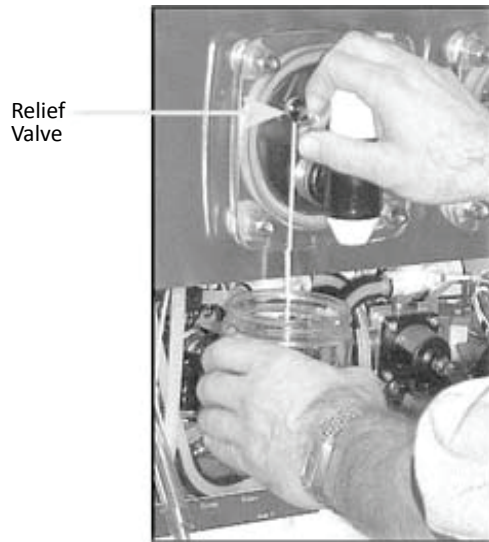

Figure 27.

12. Repeat steps 10 and 11 for the other freeze cylinders.
  13. Press BACK twice to go to the Main menu.
  14. Press ON, after 5 seconds the compressor will start and the beater bars will rotate counterclockwise. Wait 10 – 15 minutes and test the product.
- NOTE: Make sure the controller is programmed before pressing ON.**
15. Install the second side panel, splash panel, drip tray, and top cover.

## SECTION 2: SHUT-OFF VALVE AND BLENDONATOR OUTLET BRX SAMPLE TUBE PROCEDURE

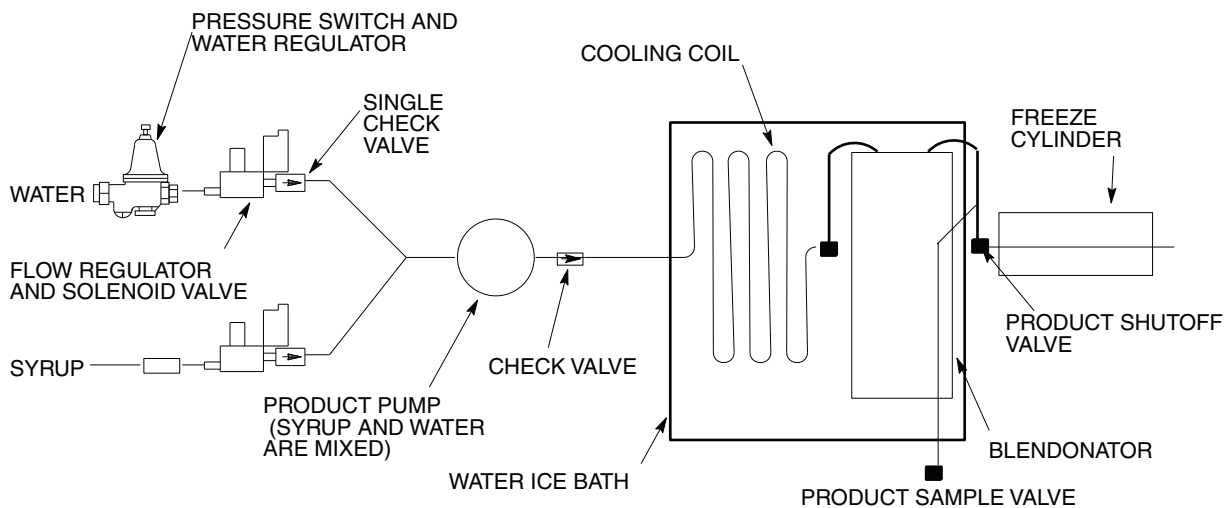

Figure 28.

The BRIX menu allows the activation of syrup and water solenoids, and blendonator pump motor for a selected cylinder.

1. Press MENU.
2. Scroll up to BLENDONATOR.
3. Turn Blendonators 1 and 2 OFF.
4. Drain each Blendonator through the BRIX Sample Valve.
5. Press BACK.
6. Scroll down to BRIX.
7. Press GO.
8. Once the BRIX SELECT menu is selected press GO to partially fill Blendonator #1 with a BRIX sample.
9. After the sample is complete (Blendonator pump has stopped turning), remove the sample from the Blendonator (through the BRIX Sample Valve) for refractometer testing.
10. If the BRIX reading is within specification, the BRIX adjustment for this barrel is complete.
11. If the BRIX reading is NOT within specification, adjust the syrup Flow Control to bring the product within specification (clockwise to increase BRIX, counter-clockwise to decrease BRIX). Adjust Flow Control in no more than 1/2 turn increments.
12. Repeat step 8 above 3 times, drain the Blendonator, and dispose of this product.
13. Repeat steps 8 and 9 above and measure the sample with the refractometer.
14. Repeat steps 11-13 until the product BRIX is within specification.
15. Repeat steps 8-14 until Blendonator #2 product BRIX is within specification.
16. Scroll to the BLENDONATOR menu and turn both Blendonators ON.





**Cornelius Inc.**  
**[www.cornelius.com](http://www.cornelius.com)**