

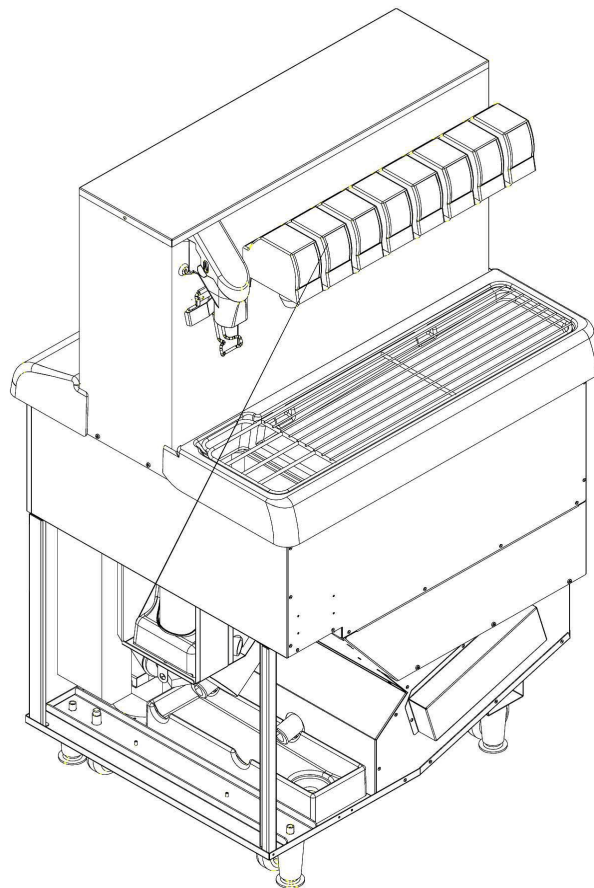

MODEL: PR150 BC
The Profile™ Ice/Drink Dispenser
Operator's Manual



Release Date: October 5, 2001
Publication Number: 620918702
Revision Date: August 3, 2010
Revision: F

Visit the IMI Cornelius web site at www.cornelius.com for all your Literature needs.

The products, technical information, and instructions contained in this manual are subject to change without notice. These instructions are not intended to cover all details or variations of the equipment, nor to provide for every possible contingency in the installation, operation or maintenance of this equipment. This manual assumes that the person(s) working on the equipment have been trained and are skilled in working with electrical, plumbing, pneumatic, and mechanical equipment. It is assumed that appropriate safety precautions are taken and that all local safety and construction requirements are being met, in addition to the information contained in this manual.

This Product is warranted only as provided in Cornelius' Commercial Warranty applicable to this Product and is subject to all of the restrictions and limitations contained in the Commercial Warranty.

Cornelius will not be responsible for any repair, replacement or other service required by or loss or damage resulting from any of the following occurrences, including but not limited to, (1) other than normal and proper use and normal service conditions with respect to the Product, (2) improper voltage, (3) inadequate wiring, (4) abuse, (5) accident, (6) alteration, (7) misuse, (8) neglect, (9) unauthorized repair or the failure to utilize suitably qualified and trained persons to perform service and/or repair of the Product, (10) improper cleaning, (11) failure to follow installation, operating, cleaning or maintenance instructions, (12) use of "non-authorized" parts (i.e., parts that are not 100% compatible with the Product) which use voids the entire warranty, (13) Product parts in contact with water or the product dispensed which are adversely impacted by changes in liquid scale or chemical composition.

Contact Information:

To inquire about current revisions of this and other documentation or for assistance with any Cornelius product contact:

www.cornelius.com

800-238-3600

Trademarks and Copyrights:

This document contains proprietary information and it may not be reproduced in any way without permission from Cornelius.

Printed in U.S.A.



TABLE OF CONTENTS

Safety Instructions	1
Read and Follow ALL Safety Instructions	1
Safety Overview	1
Recognition	1
Different Types of Alerts	1
Safety Tips	1
Qualified Service Personnel	1
Safety Precautions	2
Shipping And Storage	2
CO2 (Carbon Dioxide) Warning	2
Mounting in or on a Counter	2
Description	3
Specifications	3
Installation Instructions	4
Countertop Installation	4
Cleaning and Maintenance Instructions	7
Daily Cleaning:	7
Daily Maintenance:	7
Weekly Cleaning: (In addition to daily procedures)	7
Monthly Cleaning: (In addition to daily and weekly procedures)	8
Yearly Maintenance:	8
Unit Requiring Remote Carbonator	8
Adjusting Syrup Source CO2 Regulator	8
Adjusting Dispensing Valves Water Flow Rate (see Figure 3)	8
Adjusting Water-To-Syrup “Ratio” (Brix) Of Dispensed Product	9
Start-Up and Operating Instructions	11
Auger Assembly Breakdown	11
Cleaning And Sanitizing Instructions	12
Cleaning Dispenser	12
Cleaning Exterior Surfaces	12
Cleaning Interior Surfaces	12
Auger Housings	13
Cleaning Dispensing Valves	13
Sanitizing Syrup Tanks System	13
Sanitize B-I-B Systems	14
Ice Auger Speed Control	14
Troubleshooting	17



Illustrated Parts List	19
PR150BC Assembly Parts List	22

SAFETY INSTRUCTIONS

READ AND FOLLOW ALL SAFETY INSTRUCTIONS

Safety Overview

- Read and follow **ALL SAFETY INSTRUCTIONS** in this manual and any warning/caution labels on the unit (decals, labels or laminated cards).
- Read and understand **ALL** applicable OSHA (Occupational Safety and Health Administration) safety regulations before operating this unit.

Recognition

<i>Recognize Safety Alerts</i>

<i>This is the safety alert symbol. When you see it in this manual or on the unit, be alert to the potential of personal injury or damage to the unit.</i>

DIFFERENT TYPES OF ALERTS

DANGER:

Indicates an immediate hazardous situation which if not avoided **WILL** result in serious injury, death or equipment damage.

WARNING:

Indicates a potentially hazardous situation which, if not avoided, **COULD** result in serious injury, death, or equipment damage.

CAUTION:

Indicates a potentially hazardous situation which, if not avoided, **MAY** result in minor or moderate injury or equipment damage.

SAFETY TIPS

- Carefully read and follow all safety messages in this manual and safety signs on the unit.
- Keep safety signs in good condition and replace missing or damaged items.
- Learn how to operate the unit and how to use the controls properly.
- **Do not** let anyone operate the unit without proper training. This appliance is **not** intended for use by very young children or infirm persons without supervision. Young children should be supervised to ensure that they do not play with the appliance.
- Keep your unit in proper working condition and do not allow unauthorized modifications to the unit.

QUALIFIED SERVICE PERSONNEL

WARNING:

Only trained and certified electrical, plumbing and refrigeration technicians should service this unit. **ALL WIRING AND PLUMBING MUST CONFORM TO NATIONAL AND LOCAL CODES. FAILURE TO COMPLY COULD RESULT IN SERIOUS INJURY, DEATH OR EQUIPMENT DAMAGE.**

SAFETY PRECAUTIONS

This unit has been specifically designed to provide protection against personal injury. To ensure continued protection observe the following:

WARNING:

Disconnect power to the unit before servicing following all lock out/tag out procedures established by the user. Verify all of the power is off to the unit before any work is performed.

Failure to disconnect the power could result in serious injury, death or equipment damage.

CAUTION:

Always be sure to keep area around the unit clean and free of clutter. Failure to keep this area clean may result in injury or equipment damage.

SHIPPING AND STORAGE

CAUTION:

Before shipping, storing, or relocating the unit, the unit must be sanitized and all sanitizing solution must be drained from the system. A freezing ambient environment will cause residual sanitizing solution or water remaining inside the unit to freeze resulting in damage to internal components.

CO₂ (CARBON DIOXIDE) WARNING

DANGER:

CO₂ displaces oxygen. Strict attention **MUST** be observed in the prevention of CO₂ gas leaks in the entire CO₂ and soft drink system. If a CO₂ gas leak is suspected, particularly in a small area, **IMMEDIATELY** ventilate the contaminated area before attempting to repair the leak. Personnel exposed to high concentrations of CO₂ gas experience tremors which are followed rapidly by loss of consciousness and **DEATH**.

MOUNTING IN OR ON A COUNTER

WARNING:

When installing the unit in or on a counter top, the counter must be able to support a weight in excess of 450 lbs. to insure adequate support for the unit. **FAILURE TO COMPLY COULD RESULT IN SERIOUS INJURY, DEATH OR EQUIPMENT DAMAGE.**

NOTE: Many units incorporate the use of additional equipment such as ice makers. When any addition equipment is used you must check with the equipment manufacturer to determine the additional weight the counter will need to support to ensure a safe installation.



DESCRIPTION

The Under Counter ice dispenser solves your ice service needs in a sanitary, space saving, economical way. Designed to be manually filled with ice this dispenser will dispense cubes (up to 1-1/4" in size), cubelets and hard chipped or cracked ice.

SPECIFICATIONS

Model:	PR150 BC Ice Drink Dispenser (Eight-Flavor)
Dimensions	31-7/8 inches wide X 27-7/8 inches Deep X 21-1/4 inches High with 29 inches Depth Below Counter Top
Electrical	120 VAC/1 Phase/60 Hz/5.2 Amps Total Current Draw
Recommended Electrical Supply	115 VAC/60 Hz/15.0 Amps, 3-Wire Grounded Circuit
Clearance Required	54 In. above counter front access.
Drain	Base Unit is plumbed for PVC or flex plastic tubing installed to local code.
CO ₂ or Air Requirements	CO ₂ = 80-100 PSI supply (preferred) or air = 70 PSI minimum supply.
Flavor Selections	Maximum of eight syrup flavors plus plain water and carbonated water.
Cup Selection	Five Sizes (12, 16, 21, 32, and 42 Oz.)
Ice Requirements	Ice bin capacity is 150 pounds of ice.
Water Supply	60-PSI flowing pressure (3/4 inch supply with shutoff valve)
Drink Draw Rate	Dispenses seven 21 oz. drinks per minute at or below 40° F continuous.

INSTALLATION INSTRUCTIONS

Counter Height (inches)	Dispenser Depth (inches)	Available Space Below Dispenser (inches)	Use Kit No.
30	29	1	Consult Factory
31	29	2	Consult factory
32	29	3	620517502 and 629087406
33	29	4	629087406
34	29	5	629087406
34-1/2	29	5-1/2	629087412 and 620517502
35	29	6	629087412
36	29	7	629087412

COUNTERTOP INSTALLATION

WARNING:

It is the responsibility of the installer to ensure that the water supply to the dispensing equipment is provided with protection against backflow by an air gap as defined in ANSI/ASME A112. 1.2-1976; or an approved vacuum breaker or other such method as proved effective by test and must comply with all federal, state and local codes.

Failure to comply could result in serious injury, death or damage to the equipment.

IMPORTANT: Water pipe connections and fixtures directly connected to a potable water supply must be sized, installed, and maintained according to federal, state and local laws.

1. Locate the dispenser indoors on a level countertop.

The dispenser *must* be sealed to the countertop. The MOUNTING TEMPLATE (see Figure 1) indicates the opening that *must* be cut in the countertop. Locate the desired position for the dispenser, then mark the outline dimension on the countertop using the dimensions given or use the full size template enclosed.

Apply a continuous bead of NSF International (NSF) listed silastic sealant (Dow 732 or equivalent) approximately 1/4 inch inside the dispenser outline dimensions and around all openings. Position the dispenser on the countertop within the outline dimensions. All excess sealant *must* be wiped away immediately.

2. The drain tube is routed through the large opening in the bottom of the dispenser. See the MOUNTING TEMPLATE (see Figure 1) for locating the required clearance hole in the countertop for these utility lines. The power cord is routed through hole in the side of the dispenser electrical control box.
3. **SINK DRAIN ASSEMBLY:** Connect the drain tube to an open drain. Additional drain tubing is provided with the Dispenser. The drain tube *must* continuously pitch downward and contain no "traps" or improper drainage will result.
 - A. Use 3/4-inch nominal plastic pipe.
 - B. To assure proper drainage, *do not* allow a "trap" to form in the drain line. *Be sure* drain line runs flat with bottom of the dispenser.
4. Clean the hopper interior (See CLEANING INSTRUCTIONS).
5. Connect dispenser power cord to 120 VAC 60 HZ 15-Amp 3-wire grounded receptacle.

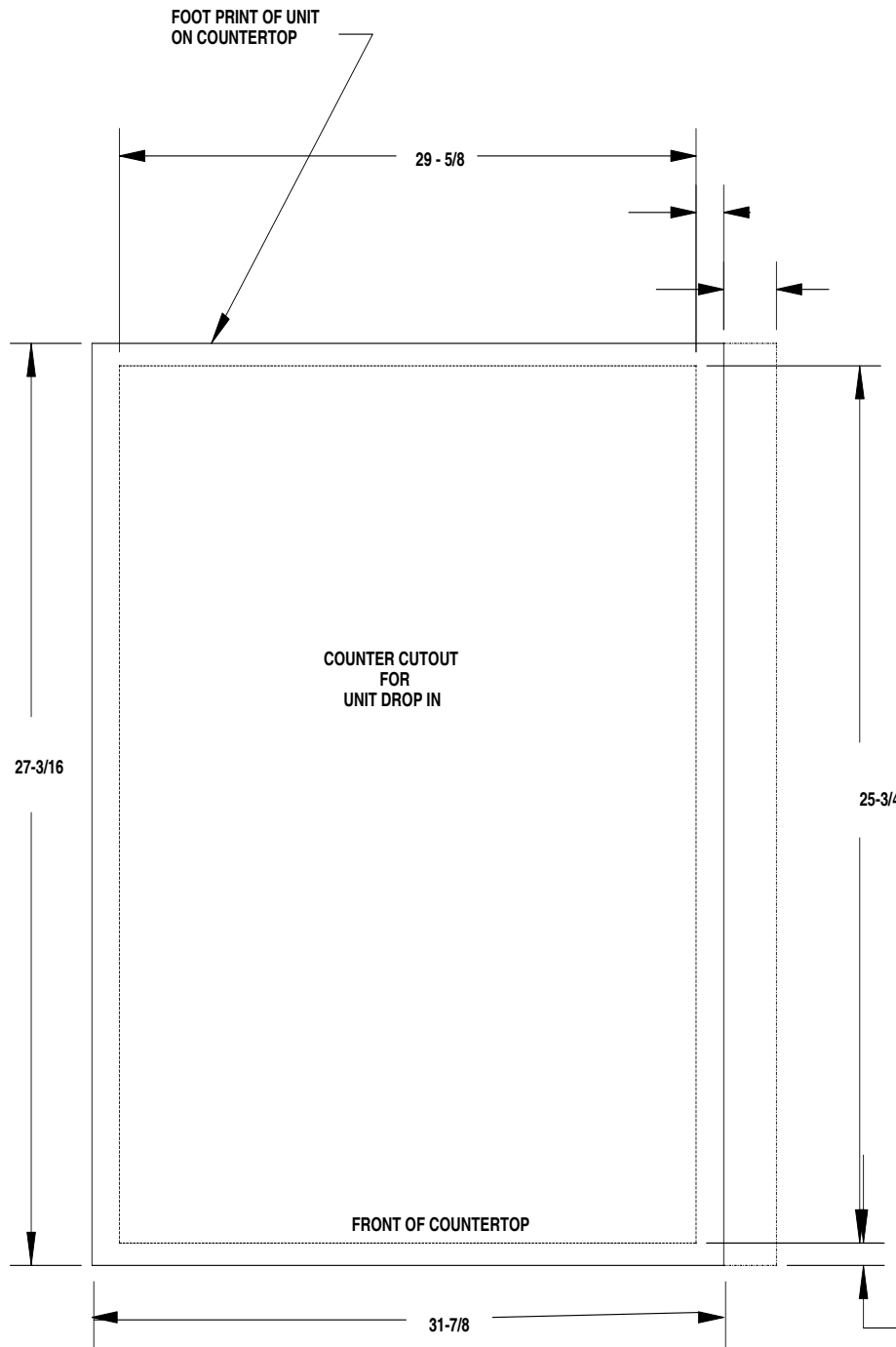

THE ABOVE FIGURE SHOWS THE REQUIRED CUTOUT FOR PLACING THE ICE DISPENSER INTO A COUNTERTOP. THE DASHED LINE IS THE ACTUAL CUTOUT DIMENSIONS WHILE THE SOLID LINE SHOWS THE AMOUNT OF OVERHANG FOR THE DISPENSER.

Figure 1. Mounting Template

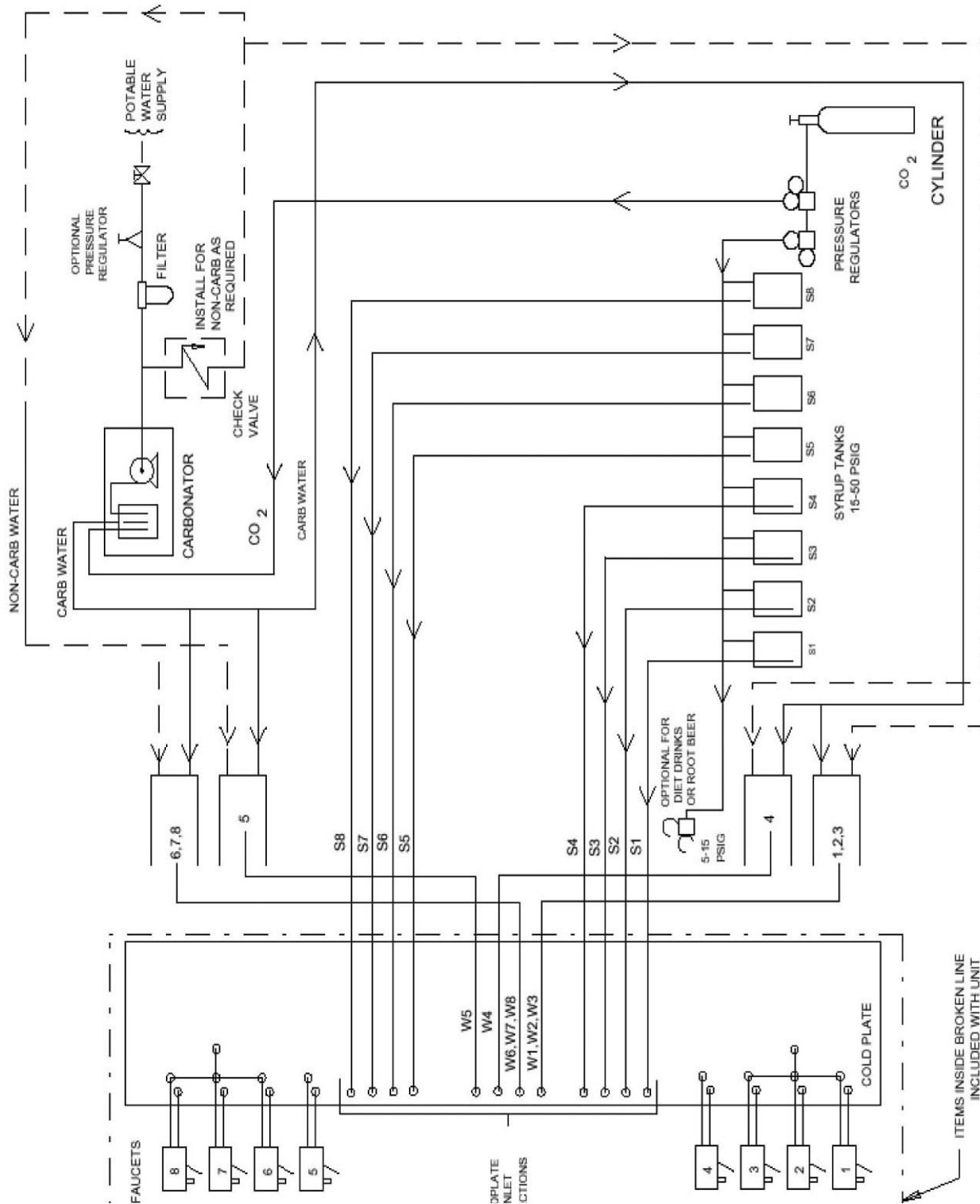

Faucets viewed from front of unit.

Figure 2. Flow Diagram

CLEANING AND MAINTENANCE INSTRUCTIONS

These instructions are used on all Cornelius ice drink dispensers. Some models may have additional cleaning requirements. Those models will have addition procedures listed later in the manual.



WARNING:

Disconnect power to the unit before cleaning or servicing following all lock out / tag out procedures established by the user. Verify all of the power is off to the unit before performing any work.

Failure to comply could result in serious injury, death or damage to the equipment.



CAUTION:

Do not use metal scrapers, sharp objects or abrasives on the ice storage hopper, top cover, agitator disc or exterior surfaces as damage to the unit may result. Do not use solvents or other cleaning agents as they may attack the material resulting in damage to the unit.

Soap solution – Use a mixture of mild detergent and warm (100° F) potable water.

Sanitizing Solution – Dissolve 2 packets (4 oz.) of Stera Sheen Green Label into 2 gallons of warm (80 – 100° F) potable water to ensure 200 ppm of chlorine.

Daily Cleaning:

1. Remove cup rest from drip tray and clean with warm soapy water, rinse with clean water and allow to air dry.
2. Wipe down the exterior of the unit with warm soapy water, rinse with clean water and allow to air dry.
3. Remove valve nozzles and diffusers and wash in warm soapy water, rinse in clean water and allow to air dry.
4. Clean the interior of the ice chute using the brush provided with the unit with warm soapy water, rinse with clean water and allow to air dry.
5. Spray the ice chute inside and out with sanitizer and allow to air dry.
6. Pour warm soapy water down the drains to keep them clean and flowing smoothly.
7. Spray the nozzles and diffusers inside and outside with approved sanitizing solution, reinstall them on the valves and allow to air dry.
8. Reinstall the cup rest into the drip tray.
9. Pour all remaining sanitizer solution down the drains to help keep the drain clear.

Daily Maintenance:

1. Check the temperature, smell and taste of the product.
2. Check the water pressure coming to the unit using the pressure gauges on the back room package.
3. Check carbonation of the drink
4. Check level of CO₂ supply to the system.
5. Check the date on all of the B-I-B's (bags in boxes).

Weekly Cleaning: (In addition to daily procedures)

Remove the ice chute cover and clean it along with the back half with warm soapy using the brush provided with the unit. Rinse with clean water and reinstall on the unit. Spray the ice chute assembly with approved sanitizer allowing it to air dry.

Monthly Cleaning: (In addition to daily and weekly procedures)

1. Flush and sanitize all syrup lines as well as all of the syrup connectors. (See the sanitize syrup lines section shown later in this manual).
2. Remove ice from hopper and clean and sanitize the hopper. (See the Cleaning the interior surfaces section shown later in this manual).
3. While cleaning the hopper use the brush provided with the unit to clean the cold plate surface. To accomplish this, the brush needs to be extended through the opening in the bottom of the hopper.

Yearly Maintenance:

Have the water pump and check valve inspected and cleaned by a qualified service technician.

Have the CO₂ gas check valve inspected and cleaned by a qualified service technician.

Remove the unit's splash and cold plate cover to clean and sanitize the cold plate surface. (See the cleaning the cold plate section shown later in this manual).

Unit Requiring Remote Carbonator

Adjust CO₂ regulator for the remote carbonator to CO₂ pressure specified in manual provided with the carbonator.

Adjusting Syrup Source CO₂ Regulator.

SUGAR SYRUP TANKS CO₂ REGULATOR

Adjust syrup tanks CO₂ regulator to a minimum of 45 psi.

SYRUP PUMPS (BAG-IN-BOX SYSTEM)

Adjust the syrup pumps CO₂ regulator to 70 psi. *DO NOT EXCEED MAXIMUM CO₂ PRESSURE SPECIFIED ON THE SYRUP PUMPS.*

ADJUSTING DISPENSING VALVES WATER FLOW RATE (SEE FIGURE 3)

1. Remove cover from the dispensing valve by lifting the front cover up 1/4 inch and pulling forward.
2. Install syrup diversion tube assembly on the dispensing valve by pushing rubber end of the syrup diversion tube onto the syrup outlet of the inner nozzle.
3. Measure the water flow rate by dispensing water into a graduated cup for a set period of time.

NOTE: Adjusting screw stops are built into the valve to prevent leakage when the screws are adjusted too far clockwise. Stop adjusting clockwise when turning resistance increases. Turn the screw counterclockwise 1-1/2 turns after the stop are contacted.

4. Turn the water flow regulator adjusting screw to the left (counterclockwise) to decrease the water flow rate or turn the adjusting screw to the right (clockwise) to increase the water flow rate, then recheck the flow rate. Adjustments should be no more than 1/4 turn at a time.
5. Remove syrup diversion tube from the dispensing valve, then install cover on the dispensing valve.

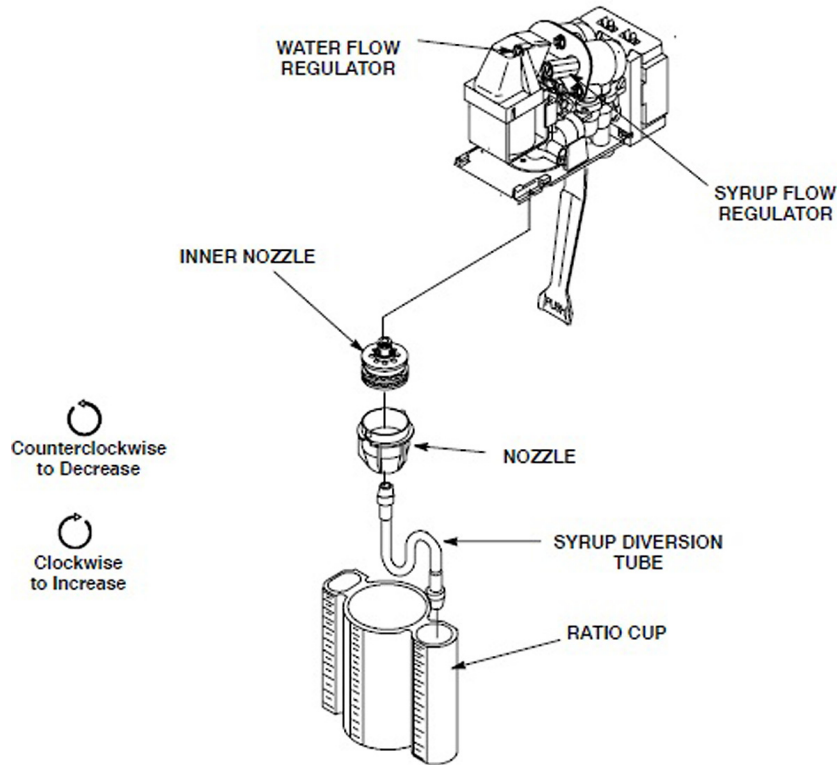

Figure 3. UF-1 Dispensing Valve

ADJUSTING WATER-TO-SYRUP “RATIO” (BRIX) OF DISPENSED PRODUCT

(see Figure 3)

NOTE: Make sure the dispensing valve water flow rate is as desired before adjusting the valve for Water-to-Syrup “Ratio” (BRIX) of the dispensed product.

Adjust Water-to-Syrup “Ratio” (BRIX) of the dispensed product by using ratio cup (P/N 311100000) and syrup diversion tube assembly (P/N 319540000) as follows:

6. Remove cover from the dispensing valve by lifting front cover up 1/4 inch and pulling forward.
7. Install syrup diversion tube assembly on the dispensing valve by pushing the rubber end of the syrup diversion tube onto the syrup outlet of the inner nozzle.

NOTE: Refer to syrup manufacturer’s recommendations on syrup package for water-to-syrup ratio.

8. Dispense enough to fill syrup diversion tube with syrup.
9. Hold large chamber of the ratio cup under the dispensing valve nozzle. Place free end of the syrup diversion tube into the syrup chamber marked for the proper ratio. Dispense approximately 6 ounces of water into the ratio cup. Water and syrup levels should be even in cup.

NOTE: Adjusting screw stops are built into the valve to prevent leakage when the screws are adjusted clockwise too much. Stop adjusting clockwise when turning resistance increases. Turn the screw counterclockwise 1-1/2 turns after the stop are contacted.



5. **Adjusting Syrup Flow Regulator** - If water and syrup levels are uneven in the ratio cup, adjust by turning the dispensing valve syrup flow regulator adjusting screw labeled **SYRUP** as follows.
 - A. For less syrup, turn the adjusting screw counterclockwise no more than 1/4 turn at a time.
 - B. For more syrup, turn the adjusting screw clockwise no more than 1/4 turn at a time.
6. Repeat water-to-syrup ratio test and adjust syrup flow regulator as many times as necessary until proper ratio of dispensed drink is achieved.
7. Remove syrup diversion tube assembly from dispensing valve.
8. Install dispensing valve front cover.

START-UP AND OPERATING INSTRUCTIONS

Fill the hopper with ice. Dispense a large cup of ice. Repeat this procedure when ever the dispenser has run out of ice.

In normal operation, pushing the ice dispenser lever will cause ice to flow from the ice chute. Ice flow will continue to flow as long as the lever is held depressed.

If the dispenser fails to dispense beverage or ice, refer to Troubleshooting section of this manual.

AUGER ASSEMBLY BREAKDOWN

1. For cleaning, the auger assembly is constructed for simple (tools not required) breakdown. First remove the tower cover (Item 69) by removing the 2 knurled screws.
2. Once the tower cap is out of the way you will see a wire retainer (Item 77). By placing your fingers on the backside of the ice chute (Item 65) with your thumbs pointing upward, place the thumbs on the retainer wire and with a slight upward movement push the wire retainer towards the rear of the unit. The retainer should pop out of the saddle and swing backwards.
3. At this point, you should be able to pull up on the ice chute and remove it from the assembly. You will notice that the ice chute is made up of three pieces. That is the ice chute, the ice chute cover and the auger gate which is respectively (Items 65, 66, and 67). Take not so that when reassembling the ice chute, the auger gate cradles in the ice chute with the short tang side up.
4. The auger (Item 73) can now be removed by just grasping it and pulling up. Notice that the bottom of the auger has a depression in the form of a D pattern. When replacing the auger, it will be necessary to rotate the auger after insertion in the tube to engage the motor shaft.

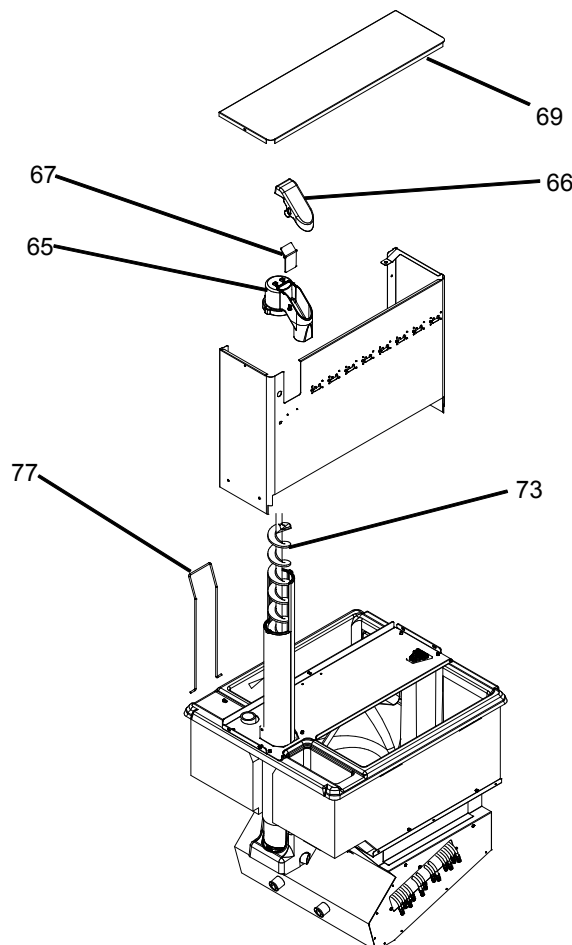

Figure 4. Auger Assembly

CLEANING AND SANITIZING INSTRUCTIONS

Soap Solution - Use a mixture of mild detergent and warm (100° F) potable water.

Sanitizing Solution - Use 1/2-ounce of household bleach in one gallon of potable water. Preparing the sanitizing solution to this ratio will create a solution of 200 PPM.

CLEANING DISPENSER

Cleaning Exterior Surfaces

IMPORTANT: Perform the following daily.

1. Remove cup rest from the drip tray.
2. Wash the drip tray with soap solution. Rinse with potable water and allow solution to run down the drain.
3. Wash cup rest with soap solution and rinse with potable water. Install cup rest in drip tray.
4. Clean all exterior surfaces of the dispenser with soap solution and rinse with potable water.

Cleaning Interior Surfaces

CAUTION:

When pouring liquid into the hopper, do not exceed the rate of 1/2-gallon per minute.

IMPORTANT: Perform the following at least once a month.

1. Lift drip tray to expose the hopper, then remove all ice from the hopper.
2. The drip tray can be removed from the dispenser by grasping at rear side panels and pulling gently outward.

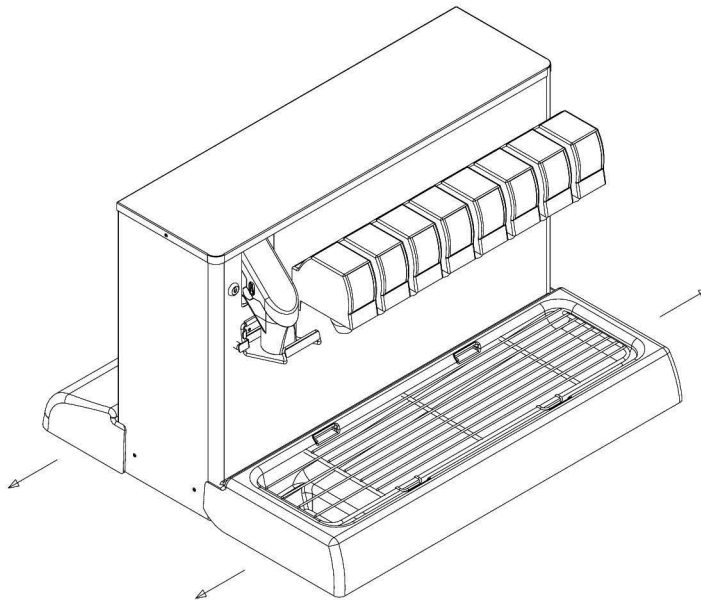

Figure 5. Drip Tray and Rear Cover Removal

3. Remove agitator disk and agitator assembly.
4. Remove tower cover by removing two thumb screws.
5. Move the retaining bail to the rear of the tower which will allow removal of the ice chute assembly.
6. Grasp the auger by the shaft end and lift out the auger tube. Take care not to damage either end of the auger.
7. Remove the auger tube by lifting upward. The tube separates into two halves for easy cleaning, when fully removed.

8. Open the front door of the cabinet below the hopper. This will give you access to the lower auger drive area and the passage between the hopper and the auger for cleaning.
9. Using the previously prepared detergent solution, clean the valves, the hopper covers, agitator disk, agitator assembly, interior of the hopper, both halves of the ice chute, auger, auger tubes, and the lower auger area of the auger housing. Thoroughly rinse all of the previously cleaned parts with potable water.
10. Reassemble the agitator assembly and disc into the hopper. Make certain the retaining screw is tight.
11. Using a mechanical spray bottle filled with sanitizing solution, spray the entire interior of the hopper and the agitator assembly. Go to the lower auger drive area and also spray with sanitizing solution. Allow to air dry.
12. Using the spray bottle, spray the inside of the two halves of the auger tube, the auger, the two halves of the chute assembly, and the undersides of the right and left covers. Allow to air dry.
13. Reassemble the two halves of the auger tube and place back into it's mounting. Holding the auger by the upper shaft end, insert into the guide tube. Make certain that the auger slips into it's drive pin. The chute assembly will not assemble properly if the auger is not seated on it's drive pin. Reassemble the upper auger and chute assembly onto the auger and lock down by snapping the ball onto the upper housing. Reinstall the tower cover with the thumb screws.
14. Reinstall the covers. Put the right cover on first before you close the left cover.

Auger Housings

Last are the auger housings (Items 74 and 75). They are dislodged by pulling upward. Check their orientation and the fact that the longer tube is on the front side. When positioning the housings back in the dispenser, the longer tube should be placed first so as to seat in the lower housing to set up the orientation (top and bottom are marked on end of the tube tab at the top), otherwise the ice chute spout will not point towards the front of the dispenser.

CLEANING DISPENSING VALVES

Refer to addendum supplied with the unit that is applicable to the manufacturer of the valves installed on the unit.

Sanitizing Syrup Tanks System



CAUTION:

Only trained and qualified persons should perform these cleaning and sanitizing procedures.

Sanitize syrup tanks system as follows:

1. Remove all the quick disconnects from all the tanks. Fill a suitable pail or bucket with soap solution.
2. Submerge all disconnects (gas and liquid) in the soap solution and then clean them using a nylon bristle brush. **(Do not use a wire brush)**. Rinse with clean water.
3. Prepare sanitizing solution and using a mechanical spray bottle, spray the disconnects. Allow to air dry.
4. Using a clean, empty tank, prepare five (5) gallons of the sanitizing solution. Rinse the tank disconnects with approximately 9 oz. of the sanitizing solution. Close the tank.
5. Prepare to clean tank by filling clean five (5) gallon bucket with a mixture of mild detergent and potable water (120°F).
6. Connect a gas disconnect to the tank and then apply one of the product tubes to the cleaning tank. Operate the appropriate valve until liquid dispensed is free of any syrup.
7. Disconnect cleaning tank and hook up sanitizing tank to syrup line and CO₂ system.
8. Energize beverage faucet until chlorine sanitizing solution is dispensed through the faucet. Flush at least two (2) cups of liquid to ensure that the sanitizing solution has filled the entire length of the syrup tubing.
9. Allow sanitizer to remain in lines for fifteen (15) minutes.
10. Repeat step above, applying a different product tube each time until all tubes are filled with sanitizing solution.
11. For post-mix valves, remove the nozzle and syrup diffuser and clean them in a mild soap solution. Rinse with clean water and reassemble the nozzle and syrup diffuser on the valve.

12. For pre-mix valves, disconnect all product tubes from the tank of sanitizing solution and then open the valves to allow the pressure to be relieved. Remove the valves from the dispenser, disassemble and wash thoroughly in a mild soap solution.
13. Rinse the parts in clean water, reassemble the valve and reconnect it to the dispenser.
14. Discard the tank of sanitizing solution and reconnect the product (syrup or pre-mix) tanks. Operate the valves until all sanitizer has been flushed from the system and only product (syrup or pre-mix) is flowing.

Sanitize B-I-B Systems

1. Remove all the quick disconnects from all the B-I-B containers.
2. Fill a suitable pail or bucket with soap solution.
3. Submerge all disconnects (gas and liquid) in the soap solution and then clean them using a nylon bristle brush. **(Do not use a wire brush)**. Rinse with clean water.
4. Using a plastic pail, prepare approximately five (5) gallons of sanitizing solution.
5. Rinse the B-I-B disconnects in the sanitizing solution.
6. Sanitizing fittings must be attached to each B-I-B disconnect. If these fittings are not available, the fittings from empty B-I-B bags can be cut from the bags and used. These fittings open the disconnect so the sanitizing solution can be drawn through the disconnect.
7. Place all the B-I-B disconnects into the pail of sanitizing solution. Operate all the valves until the sanitizing solution is flowing from the valve. Allow sanitizer to remain in lines for fifteen (15) minutes.
8. Remove the nozzle and syrup diffuser from each valve and clean them in a soap solution. Rinse with clean water and reassemble the nozzle and syrup diffuser to the valve.
9. Remove the sanitizing fittings from the B-I-B disconnects and connect the disconnects to the appropriate B-I-B container. Operate the valves until all sanitizer has been flushed from the system and syrup is flowing freely.

ICE AUGER SPEED CONTROL

The ice auger is a variable speed device. A potentiometer is used to control this speed. The potentiometer is located on the CB 1 control board (see Figure 4). The CB 1 control board is located inside the electrical control box which is below the counter facing towards the front of the counter. Removing the three screws and cover exposes the CB 1 Control board. By turning the potentiometer knob, located on the CB1 control board, CCW (counterclockwise) it increases the speed of ice delivery. Turning the potentiometer knob CW (clockwise) decreases the speed of ice delivery.

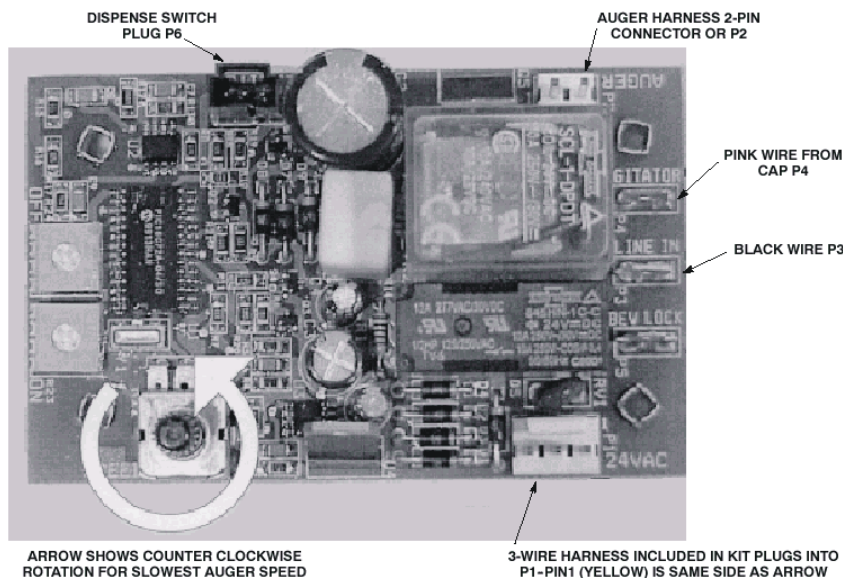

Figure 6. Ice Auger Speed Control

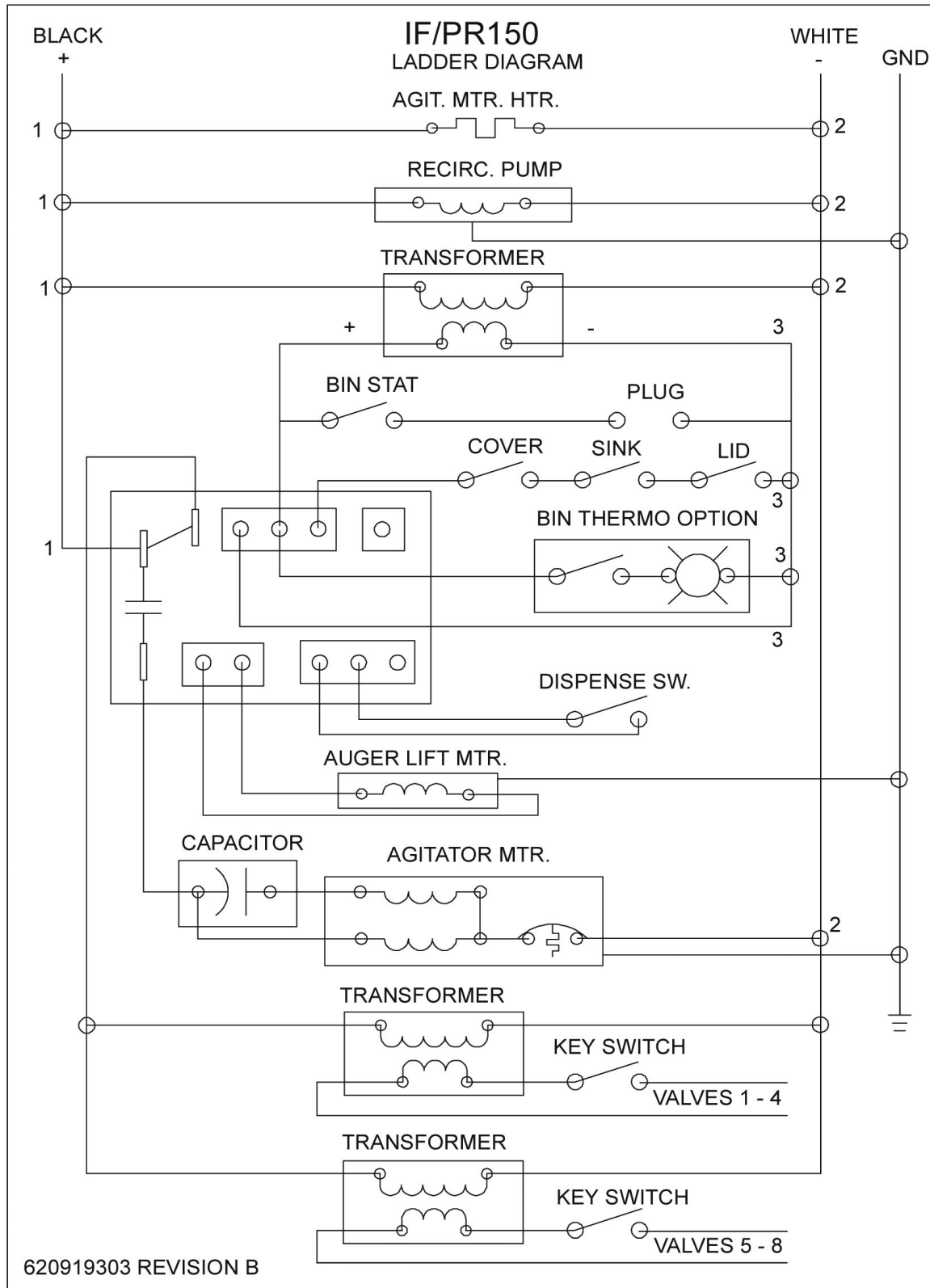

Figure 8. Ladder Diagram

TROUBLESHOOTING

WARNING:

If repairs are to be made to a syrup system, disconnect syrup supply from the applicable syrup system, then relieve the system pressure before proceeding. If repairs are to be made to the CO2 system, stop dispensing, shut off the CO2 supply, then relieve the system pressure before proceeding. If repairs are to be made to the unit electrical system, make sure electrical power is disconnected from the unit before proceeding.

IMPORTANT: Only qualified Personnel should service internal components or electrical wiring

Should your unit fail to operate properly, check that there is power to the unit and that the hopper contains ice. If the unit does not dispense, check the following chart under the appropriate symptoms to aid in locating the defect.

Trouble	Probable Cause	Remedy
BLOWN FUSE OR CIRCUIT BREAKER	<ul style="list-style-type: none"> A. Short circuit in electrical wiring. B. Inoperative 24 VAC transformer. C. Inoperative agitator motor. D. Shorted motor. 	<ul style="list-style-type: none"> A. Repair electrical wiring. B. Replace transformer. C. Replace agitator motor. D. Replace Agitator Auger motor.
AGITATOR DOES NOT TURN, AUGER DOES NOT TURN.	<ul style="list-style-type: none"> A. A.No electrical power. B. Bent depressor plate (does not actuate switch). C. Inoperative dispensing switch. D. Inoperative interlocks, lids not closed. E. Inoperative timer board. F. Inoperative 24 VAC transformer. 	<ul style="list-style-type: none"> A. Restore electrical power. B. Replace depressor plate. C. Replace dispensing switch. D. Replace interlocks. E. Replace timer board. F. Replace transformer.
ICE DISPENSES CONTINUOUSLY.	<ul style="list-style-type: none"> A. Stuck or bent depressor plate (does not release switch). B. Inoperative dispensing switch. C. Improper switch installation. D. Inoperative timer board. 	<ul style="list-style-type: none"> A. Replace depressor plate. B. Replace dispensing switch. C. Correct switch installation. D. Replace timer board.
SLUSHY ICE. WATER IN HOPPER.	<ul style="list-style-type: none"> A. Blocked drain. B. Unit not sitting level. C. Poor ice quality due to water quality or ice maker problems. D. Improper use of flaked ice. 	<ul style="list-style-type: none"> A. Unplug and flush out the drain. B. Level the unit. C. Install water filter system. For ice maker problems, consult ice maker manual. D. Use correct ice.
AGITATOR TURNS, AUGER DOES NOT TURN.	<ul style="list-style-type: none"> A. Inoperative auger motor. B. Inoperative or improper setting of speed control. C. Inoperative rectifier. D. Ice jam. E. Inoperative timer board. 	<ul style="list-style-type: none"> A. Replace auger motor. B. Replace speed control or re-adjust speed control. C. Replace rectifier. D. Clear ice jam. E. Replace timer board.
AUGER TURNS, AGITATOR DOES NOT.	<ul style="list-style-type: none"> A. Inoperative agitator motor. B. Inoperative motor capacitor. C. Inoperative timer board. 	<ul style="list-style-type: none"> A. Replace agitator motor. B. Replace motor capacitor. C. Replace timer board.
BEVERAGES DONOT DISPENSE	<ul style="list-style-type: none"> A. No 24 volts to dispensing valves. B. No CO2 pressure. 	<ul style="list-style-type: none"> A. Make sure unit is connected to electrical power. Check 24 VAC transformer. B. Check CO2 regulator. Check CO2 tank pressure.



BEVERAGES TOO SWEET.	<ul style="list-style-type: none"> A. Carbonator not operating. B. No CO₂ Pressure in carbonator. C. Dispensing valve BRIX requires re-adjustment. 	<ul style="list-style-type: none"> A. Consult carbonator manual. B. Check CO₂ regulator. Check CO₂ tank pressure. C. Refer to dispensing valve manufacturer for BRIX adjustment instructions.
BEVERAGES NOT SWEET ENOUGH	<ul style="list-style-type: none"> A. Depleted syrup supply. B. Dispensing valve BRIX requires re-adjustment. 	<ul style="list-style-type: none"> A. Replenish syrup supply. B. Refer to dispensing valve manufacturer for BRIX adjustment instructions.
BEVERAGES NOT COLD.	<ul style="list-style-type: none"> A. Unit standing with no ice in it's hopper. 	<ul style="list-style-type: none"> A. Replenish ice supply.

NOTE: Contact your local syrup or beverage equipment distributor for additional information and trouble shooting of your beverage system.

ILLUSTRATED PARTS LIST

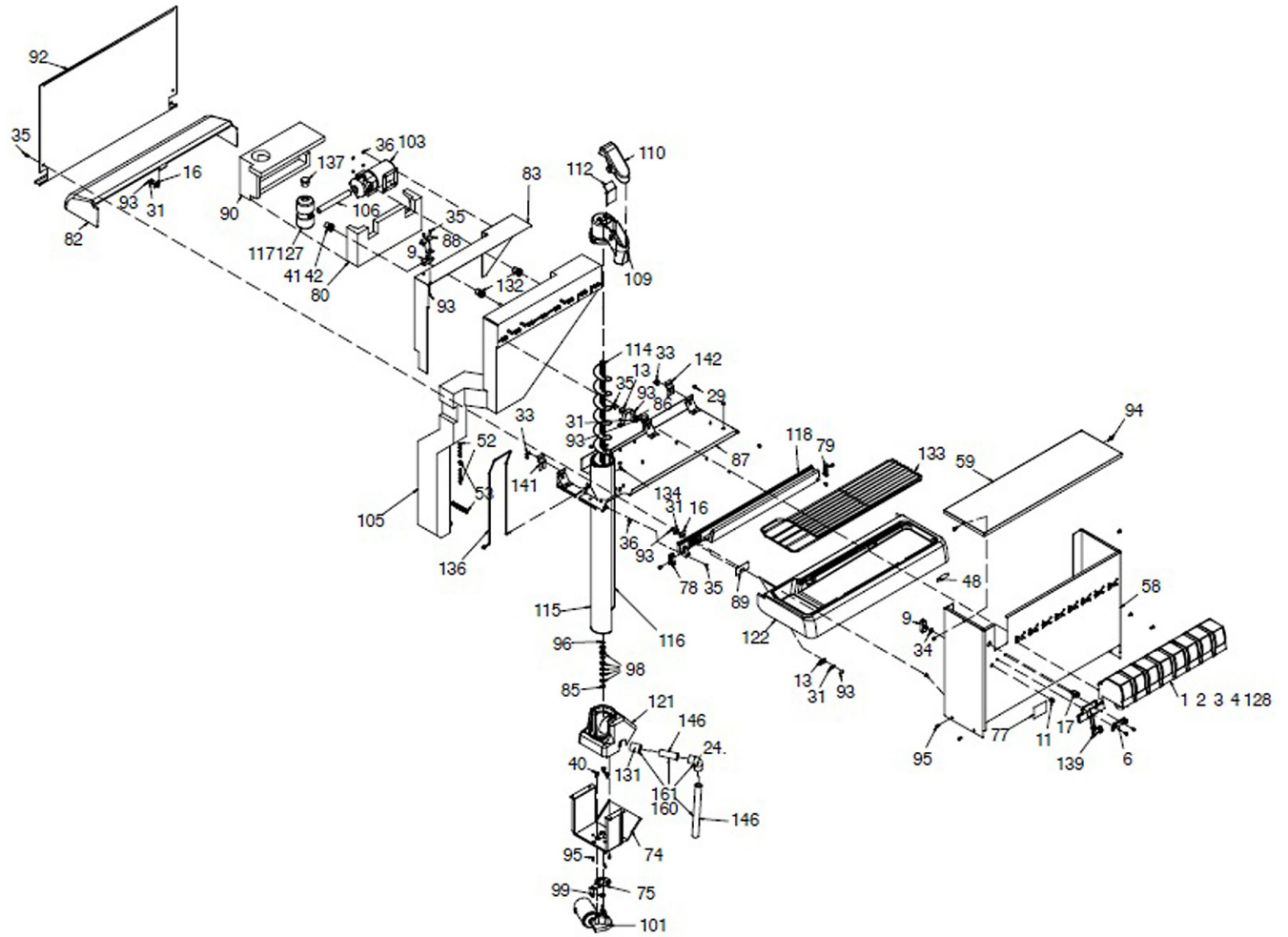

Figure 9.

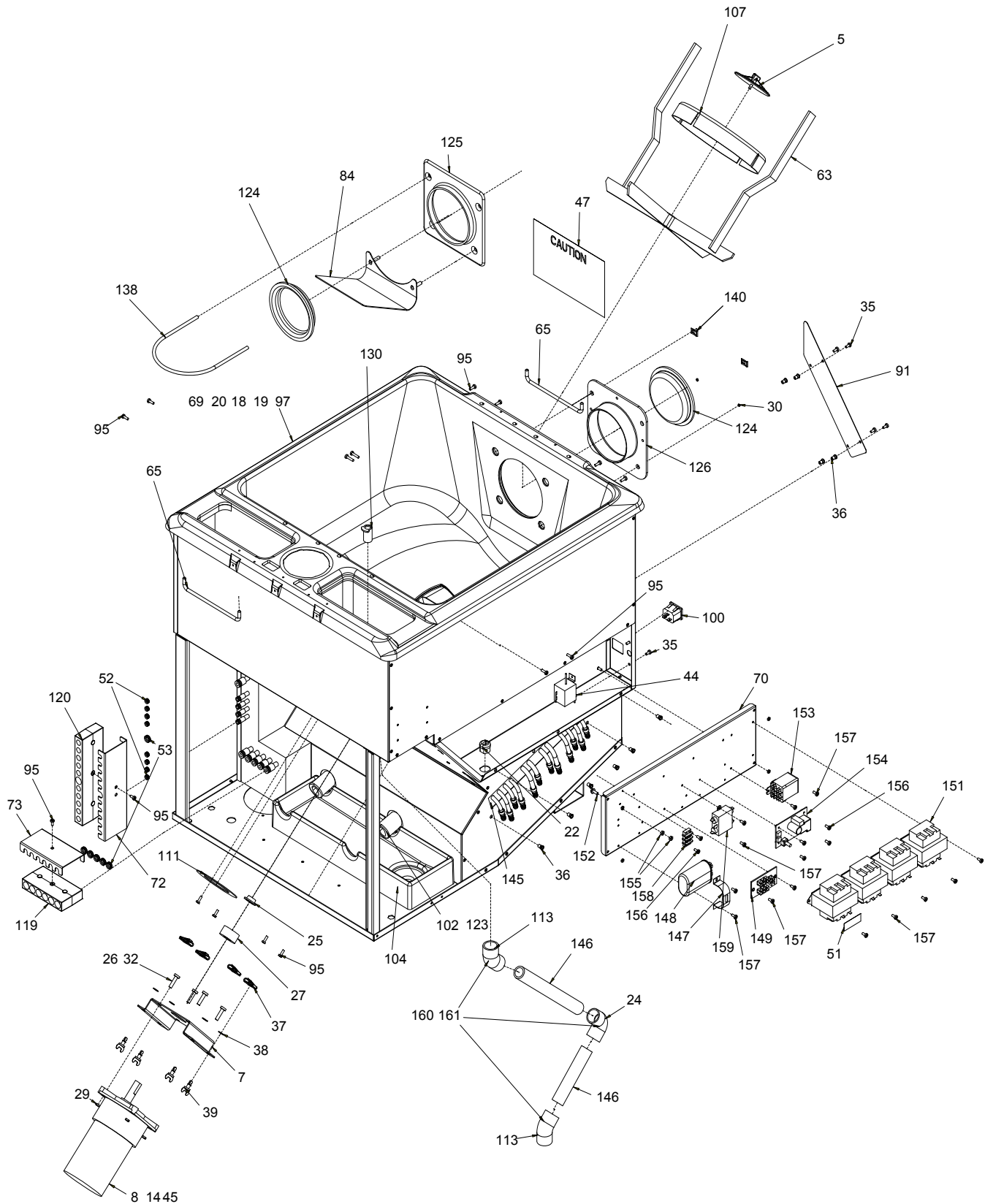

Figure 10.

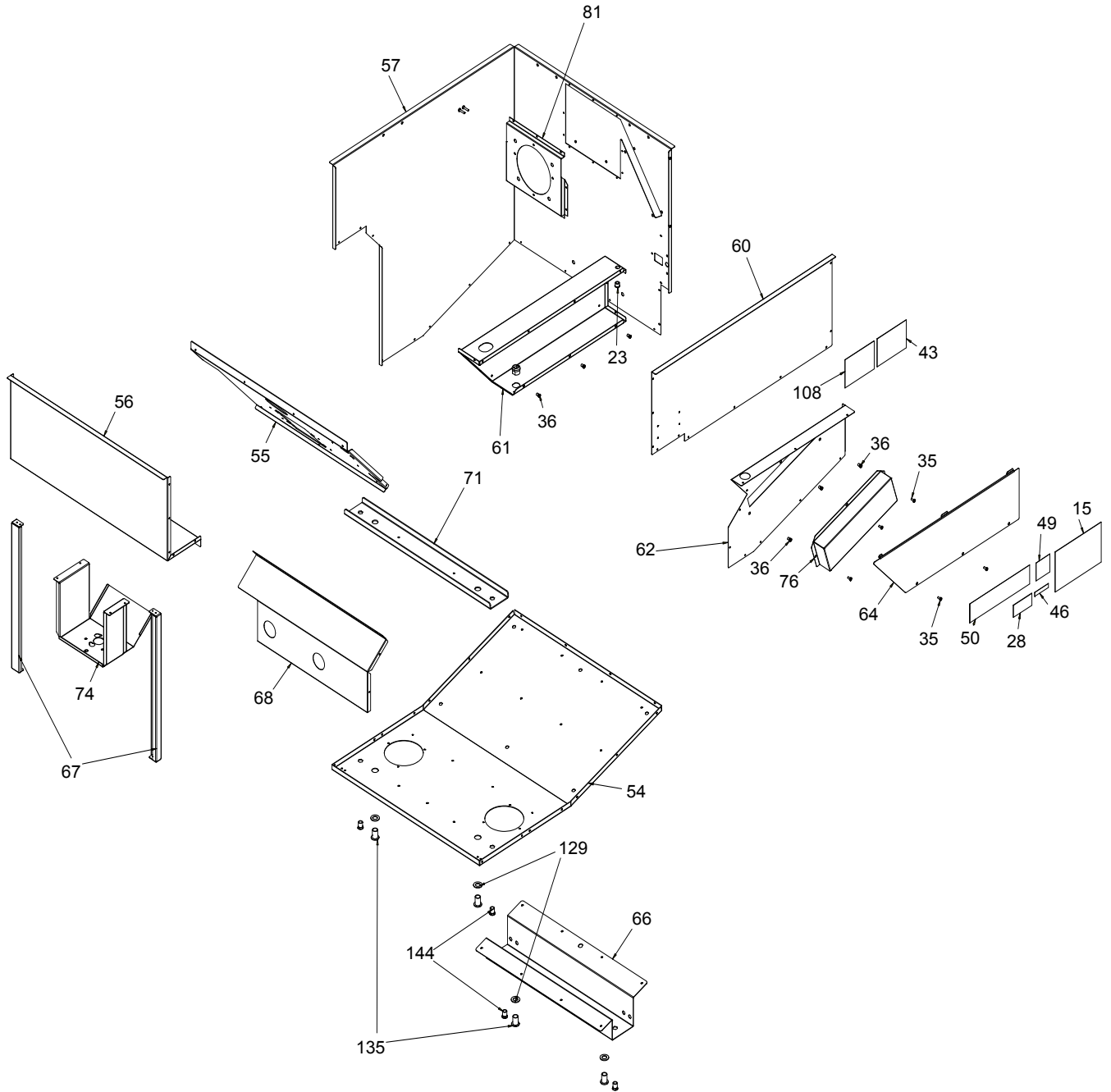

Figure 11.



PR150BC ASSEMBLY PARTS LIST

Item No.	Part No.	Name
1	1919	Mounting Block Ass'y, UF-1
2	1950	Cover, Valve, Back
3	1951	Cover, Valve, Front
4	1966	Dispensing Valve
5	15087	Retainer, Agitator
6	27107	Retainer, Ice Lever
7	29303R	Plate, Motor Mount
8	30794 32826	Heater, Agitator Motor, 115v Heater, Agitator Motor, 230v
9	02070	Kit Switch, includes switch, boot, and spacer
10	30995 620302901	Cord Ass'y, 115v Cord Ass'y, 230v
11	31007	Boot, Switch
12	31827	Wire Harness, Dispensing Valve
13	31981	Actuator
14	620307901 32824	Gear Motor Kit, 115/120V 50/60HZ, includes motor, seal gasket, and hardware Gear Motor, 230v 50/60HZ
15	620913101 620919341	Label, Wiring 115v Label, Wiring 230v
16	32953	Reed Switch Ass'y
17	32977	Switch, Key
18		
19		
20		
21		
22	50458	Strain Relief
23	50573	Snap Bushing, .375 I.D.
24	50951	Fitting, Elbow
25	51859	Seal, Motor Shaft
26	52132	Adhesive, Locktite
27	52876	Gasket, Motor Shaft
28	620911202	Label, Operate Auger Speed
29	70018	Hex Nut, 1/4-20 Keps
30	70023	Hex Nut, No. 4-40 STCA Keps
31	70048	Washer, .449 I.D.
32	70260	Machine Screw, Phil Rd Hd, 1/4-20 By 1 In. Long
33	70320	Pop Rivet, 125 Dia.
34	70847	Spacer, Switch
35	70894	Machine Screw, Phil Truss Hd, No. 8-32 By 3/4 In. Long
36	70959	Nut, No. 8-32
37	70992	Receptacle, 1/4 Turn
38	70993	Retainer, 1/4 Turn
39	70994	Stud, Wing Hd, 1/4 Turn



Item No.	Part No.	Name
40	71028	Bolt, 1/4-20
41	720509208	Fitting, Push Connector, 3/8 By 3/8 NPTF
42	750700502	Clip, Locking, 3/8
43	620919303	Label, Wiring Ladder
44	638009387	Switch, Bin Control
45	90432	Label, Warning, Disconnect
46	90580	Label, Identification Data
47	90629	Label, Clean Hopper
48	91486	Medallion, Cornelius Logo
49	91956	Label, Warning Chiller Disconnect
50	92067	Label, Operation, Agitation Timer
51	92305	Label, Notice Transformer
52	31525003	O-Ring, .239 I.D. By .070 CS
53	31525017	O-Ring, .426 I.D. By .070 CS
54	620028201	Base, Cabinet
55	620028202 620028252	Plate, Motor Mount LH Plate, Motor Mount RH
56	620028204 620028269	Cover, Access LH Cover, Access RH
57	620028205 620028254	Wrap, Cabinet LH Wrap, Cabinet RH
58	620028209 620028256	Tower, Valve Mounting LH Tower, Valve Mounting RH
59	620028211	Cover, Tower Top
60	620028213 620028255	Wrap, Cabinet, Front LH Wrap, Cabinet, Front RH
61	620028214 620028257	Electrical Box LH Electrical Box RH
62	620028216 620028258	Panel, Base LH Panel, Base RH
63	620028218	Agitator Ass'y
64	620028222 620028261	Cover, Electrical Box LH Cover, Electrical Box RH
65	620028226	Bolt, 1/4-20
66	620028227	Bracket, Leg Adapter
67	620028232	Support Bracket, Auger Motor
68	620028234 620028263	Bracket, Lower Motor Mount LH Bracket, Lower Motor Mount RH
69	620028235 620517201	Hopper Ass'y LH Hopper Ass'y RH
70	620028223	Plate, Mounting
71	620028246	Stiffener, Base
72	620028249	Plate, Syrup Lines Alignment
73	620028250	Plate, Water Lines Alignment
74	620028253	Bracket, Auger Motor Mount, Right-Hand
75	620028270	Plate, Auger Motor Spacing
76	620028282	Cover, Inlet Lines
77	620906404	Label, Ice Notice



Item No.	Part No.	Name
78	620043104	End Cap, Hinge, Left-Hand
79	620043105	End Cap, Hinge, Right-Hand
80	620043201	Insulation Box Foamed
81	620043206	Ice maker Sleeve Mounting Box
82	620043507	Lid, Ice Fill, Back
83	620044601 620044602	Plate, Pump Mounting LH Plate, Pump Mounting RH
84	620044614	Plate, Deflector
85		
86	620045301	Bracket, Reed Switch
87	620045724 620045727	Base, Tower LH Base, Tower RH
88	620045904	Bracket, Dispense Switch
89	620045958	Bracket Ass'y, Interlock Switch
90	620046005	Cover, Reservoir
91	620046017	Cover, Bin Thermostat
92	620048102	Panel, Tower, Back
93	70076	Hex Nut, Keps, No. 8-32
94	70188	Screw, Knurled Hd, No. 8-32
95	70204	Screw, Self-Tapping, No. 8-32
96		
97	620711401	Insulation, Stop Ice Conduit
98	629088578	SuperSeal Kit
99		
100	620314201	Connector, Power Inlet
101	629087456 629087489	SuperSeal Upgrade Kit - units built before 2/02/2001 (Includes Motor, Seals, and Motor Housing) Motor and SuperSeal Ass'y Kit - units built after 2/01/2001 (Includes Motor and Seals)
102	620403001 620403002	Cold Plate LH Cold Plate RH
103	620403008	Pump, Recirculating
104	629087415	Drain Tray with Elbow Kit
105	620407601 620407622	Coil Pack Ass'y LH Coil Pack Ass'y RH
106	620407801	Fitting, Nipple, 1/2 By 1/2 NPTF
107	620503801	Agitator, Disk
108	620918901	Label, Plumbing
109	620504001	Ice Chute
110	620504002	Cover, Ice Chute
111	620504006	Seal, Hopper Conduit
112	620504011	Gate, Auger
113	620504021	Fitting, Elbow
114	620505502	Auger
115	620505703	Tube Ass'y, Auger, Front
116	620505704	Tube Ass'y, Auger, Back
117	620506512	Reservoir, Recirculating



Item No.	Part No.	Name
118	620506513 620506538	Hinge, Drain Trough LH Hinge, Drain Trough RH
119	620506518	Block, Connector, Water Lines
120	620506519	Block, Connector, Syrup Lines
121	620506531	Housing, Auger
122	620517136 620517138	Drip Tray Ass'y Black, LH Drip Tray Ass'y Black, RH
123		
124	620516602	Cover, Ice maker Sleeve
125	620517501	Collar, Ice maker Sleeve
126	620517601	Sleeve, Ice maker
127	620202849	Propylene Glycol
128	620700602	Sheet Metal Screw, Phil Rd Hd, No. 10-16 By 1 In. Long
129	620701123	Washer, 9/16 I.D.
130	620718101	Strainer, Drip Tray
131	620704603	Coupling
132	620704604	Fitting, 3/8 By 1/2 MPT
133	620708524	Cup Rest
134	620705201	Pushon Nut, 3/16
135	620705401	Insert Nut, 1/2-13
136	620705501	Retainer, Ice Chute Holddown
137	620708202	Plug
138	620708908	Tube, Bin Stat
139	620709301	Lever, Ice
140	620709601	Clip, Pushon
141	620709604	Clip, Back Lid, Left-Hand
142	620707605	Clip, Back Lid, Right-Hand
143	620709901	Pop Rivet, 125 Dia.
144	620710201	Insert, 3/8-16
145	620710301	Stop, Insulation Foam Inlets
146	50336	PVC Pipe, 3/4
147	30514 620045302	Strap, Capacitor 115V Strap, Capacitor 230V
148	30774 620314301	Capacitor, Agitator Motor 115v Capacitor, Agitator Motor 230v
149	31107	Terminal Board
150	33617	Wire Harness, Agitator Motor
151	449999999 560002114	Transformer, 120V 60HZ Transformer, 230V 60HZ
152	70223	Screw, No. 10-32 By 3/4 In. Long
153	33082	Relay
154	620311701 620311702	Timer, Agitator 115V Timer, Agitator 230V
155	70015	Hex Nut, No. 10-32
156	70147	Sheet Metal Screw, Phil Rd Hd, No. 6 By 1/2 In. Long
157	70217	Sheet Metal Screw, No. 8 By 1/2 In. Long



Item No.	Part No.	Name
158	32244	Terminal Board, 230V only
159	620307301	Filter
160	50158R	Armaflex
161	50326	Armaflex Tape
162	620307301	Filter RFI 230v only
163	620304601	Varistor Ass'y 230v only
164	629087412	6" Leg Kit (Not Shown)
165	629087430	Interlock Switch Bracket Kit (Not Shown)
166	70739	Key, Keyswitch Replacement (Not Shown)

IMI Cornelius Inc.
www.cornelius.com