

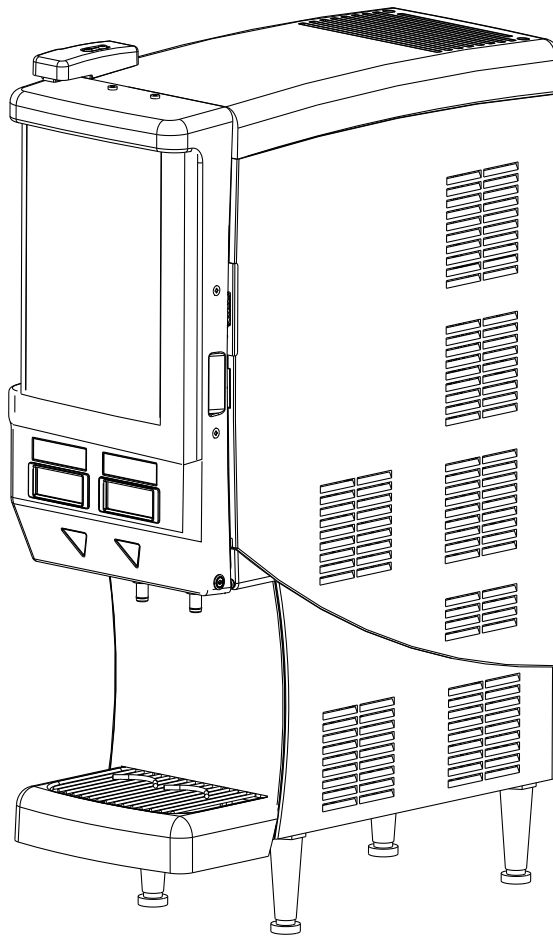

QUEST ELITE QLT 2000

Operator's, Installation and Service Manual



Release Date: December 10, 2013

Publication Number: 620058442

Revision Date: March 25, 2014

Revision: B

Visit the Cornelius web site at www.cornelius.com for all your Literature needs.

The products, technical information, and instructions contained in this manual are subject to change without notice. These instructions are not intended to cover all details or variations of the equipment, nor to provide for every possible contingency in the installation, operation or maintenance of this equipment. This manual assumes that the person(s) working on the equipment have been trained and are skilled in working with electrical, plumbing, pneumatic, and mechanical equipment. It is assumed that appropriate safety precautions are taken and that all local safety and construction requirements are being met, in addition to the information contained in this manual.

This Product is warranted only as provided in Cornelius' Commercial Warrant applicable to this Product and is subject to all of the restrictions and limitations contained in the Commercial Warranty.

Cornelius will not be responsible for any repair, replacement or other service required by or loss or damage resulting from any of the following occurrences, including but not limited to, (1) other than normal and proper use and normal service conditions with respect to the Product, (2) improper voltage, (3) inadequate wiring, (4) abuse, (5) accident, (6) alteration, (7) misuse, (8) neglect, (9) unauthorized repair or the failure to utilize suitably qualified and trained persons to perform service and/or repair of the Product, (10) improper cleaning, (11) failure to follow installation, operating, cleaning or maintenance instructions, (12) use of "non-authorized" parts (i.e., parts that are not 100% compatible with the Product) which use voids the entire warranty, (13) Product parts in contact with water or the product dispensed which are adversely impacted by changes in liquid scale or chemical composition.

Contact Information:

To inquire about current revisions of this and other documentation or for assistance with any Cornelius product contact:

www.cornelius.com

800-238-3600

Trademarks and Copyrights:

This document contains proprietary information and it may not be reproduced in any way without permission from Cornelius.

This document contains the original instructions for the unit described.

CORNELIUS INC
101 Regency Drive
Glendale Heights, IL
Tel: + 1 800-238-3600

Printed in U.S.A.

TABLE OF CONTENTS

Safety Instructions	1
Read and Follow ALL Safety Instructions	1
Safety Overview	1
Recognition	1
Different Types of Alerts	1
Safety Tips	1
Qualified Service Personnel	1
Safety Precautions	2
Shipping And Storage	2
Unit Specifications	3
Installation instructions	4
Receiving	4
Unpacking	4
Counter Location	4
Recommended Clearance	4
Installation	5
Electrical Connection	5
Power Supply	5
Water Booster System	5
Electric Booster Installation Details	5
Gas-operated Booster Installation Details	5
Booster Installation Notes:	6
Water Connection	6
Flushing System	7
Filling the Water Bath	7
Programming the Portion Control	8
Loading With Concentrate Pouches – 6.5 Liters	9
Loading with Concentrate Pouches – 3.0 & 4.5 Liters	10
Connecting the silicone tube onto the Mixing Chamber	11
Planned Maintenance	13
Daily – Flushing the system	13
Weekly – Sanitizing Dispense Parts	14
Weekly – Check Ratio (Prodecure)	15
Monthly - Clean the Air Condenser Filter	17
Semi-Annually - Clean the Water Inlet Strainer	18
Troubleshooting Guide	19
Wiring Drawing for Quest Elite Qlt-2000	22
Qlt 2000 Final Assembly	24
Qlt 2000 Door Assembly Reference (Pushbutton & Portion Control)	25

Cabinet Assembly Reference26
Tank Cover Assembly27
Refrigeration Frame Assembly Qlt 200028
Platform Assembly QLT29
Valve Block Assembly30
Electrical Box Assembly31
P/N 720521000 (For QLT Dispensers Only)31
Pouch Holder Assembly32
Recommended Spare Parts Based on 10 Units33

SAFETY INSTRUCTIONS

READ AND FOLLOW ALL SAFETY INSTRUCTIONS

Safety Overview

- Read and follow **ALL SAFETY INSTRUCTIONS** in this manual and any warning/caution labels on the unit (decals, labels or laminated cards).
- Read and understand ALL applicable OSHA (Occupational Safety and Health Administration) safety regulations before operating this unit.

Recognition

<i>Recognize Safety Alerts</i>

<i>This is the safety alert symbol. When you see it in this manual or on the unit, be alert to the potential of personal injury or damage to the unit.</i>

DIFFERENT TYPES OF ALERTS

DANGER:

Indicates an immediate hazardous situation which if not avoided **WILL** result in serious injury, death or equipment damage.

WARNING:

Indicates a potentially hazardous situation which, if not avoided, **COULD** result in serious injury, death, or equipment damage.

CAUTION:

Indicates a potentially hazardous situation which, if not avoided, **MAY** result in minor or moderate injury or equipment damage.

SAFETY TIPS

- Carefully read and follow all safety messages in this manual and safety signs on the unit.
- Keep safety signs in good condition and replace missing or damaged items.
- Learn how to operate the unit and how to use the controls properly.
- **Do not** let anyone operate the unit without proper training. This appliance is **not** intended for use by very young children or infirm persons without supervision. Young children should be supervised to ensure that they do not play with the appliance.
- Keep your unit in proper working condition and do not allow unauthorized modifications to the unit.

QUALIFIED SERVICE PERSONNEL

WARNING:

Only trained and certified electrical, plumbing and refrigeration technicians should service this unit. **ALL WIRING AND PLUMBING MUST CONFORM TO NATIONAL AND LOCAL CODES. FAILURE TO COMPLY COULD RESULT IN SERIOUS INJURY, DEATH OR EQUIPMENT DAMAGE.**

SAFETY PRECAUTIONS

This unit has been specifically designed to provide protection against personal injury. To ensure continued protection observe the following:

 **WARNING:**

Disconnect power to the unit before servicing following all lock out/tag out procedures established by the user. Verify all of the power is off to the unit before any work is performed.

Failure to disconnect the power could result in serious injury, death or equipment damage.

 **CAUTION:**

Always be sure to keep area around the unit clean and free of clutter. Failure to keep this area clean may result in injury or equipment damage.

SHIPPING AND STORAGE

 **CAUTION:**

Before shipping, storing, or relocating the unit, the unit must be sanitized and all sanitizing solution must be drained from the system. A freezing ambient environment will cause residual sanitizing solution or water remaining inside the unit to freeze resulting in damage to internal components.

UNIT SPECIFICATIONS

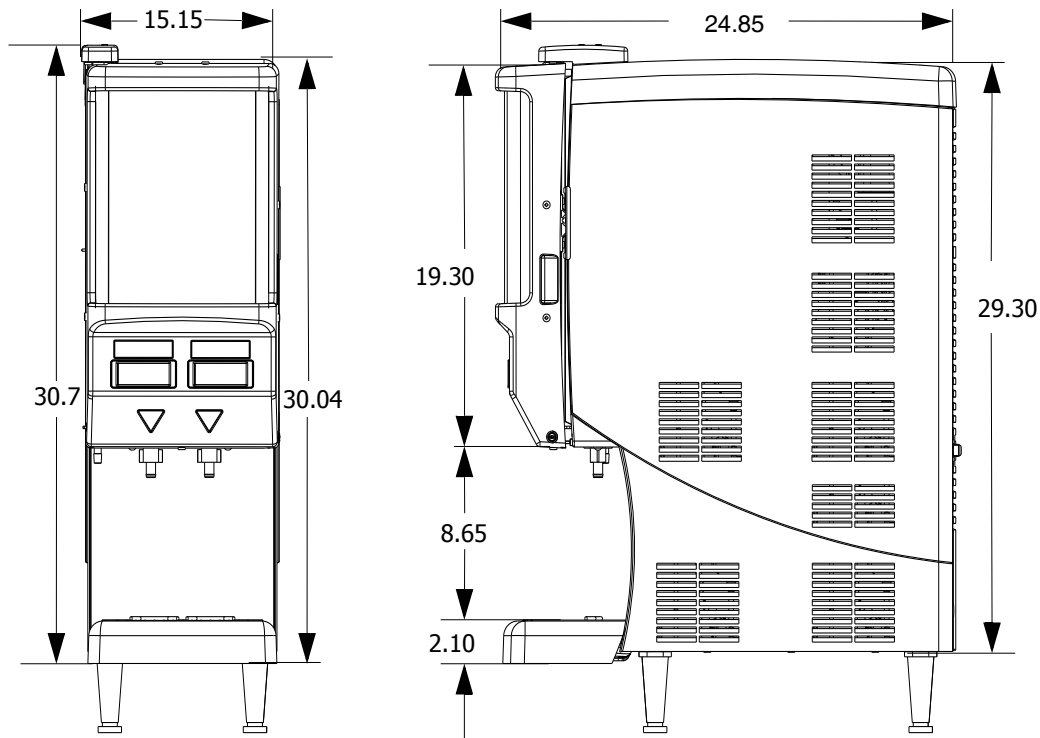

Figure 1. Unit Dimension

Model QUEST ELITE QLT - 2000, 115 VAC, 5 amps, 1 phase 60 hertz, 6.00 oz. (170gms) R-134a refrigerant.
 Test press: High side 400 psi (2757.9 kilo pascals), (27.6 bar). Low side 88 psi (606.7 kilo pascals), (6.1 bar).

Model QUEST ELITE QLT - 2000, 230 VAC, 2 amps, 1 phase 50 hertz, 6.00 oz. (170gms) R-134a refrigerant.
 Test press: High side 400 psi (2757.9 kilo pascals), (27.6 bar). Low side 88 psi (606.7 kilo pascals), (6.1 bar).

INSTALLATION INSTRUCTIONS

RECEIVING

Each unit is completely tested and inspected before shipment. At time of shipment, the carrier accepts the unit and any claim for damage must be made with the carrier.

Upon receiving from the carrier, please, inspect the carton for visible damage. If damage exists, have the carrier make a note on the bill of lading and file a claim with the carrier.

UNPACKING

- Remove staples securing carton to pallet.
- Lift carton up and off of unit.
- Remove top insert and shipping bag.
- Open upper cabinet door and remove installation kit.
- Remove bolts securing unit to pallet.
- Lift unit off of pallet.
- Open the package, take the legs and secure them to the bottom of the unit.

NOTE: Do not lay the unit on sides or on the back. This may cause vital oils to drain from the compressor resulting in damage during start-up and consequently voiding the warranty.

Tilt the unit only when securing legs. If the unit is to be transported from the place where it was unpacked, do not remove the unit from the pallet. Transport it on the pallet to the installation site.

COUNTER LOCATION

Select a location in a well ventilated area, close to a grounded electrical outlet. If possible do not place the unit close to hot and/or steaming machines. The minimum Airflow clearance is: 4" (10.16 cm) in back and 12" (30.48 cm) on top, 4" (10.16cm) on sides and open to the front is required. The space between bottom of the unit and counter cannot be obstructed.

IMPORTANT: Condenser air is drawn from the rear and discharged out the top. Failure to maintain clearance space will reduce capacity of the unit and cause premature compressor failure.

Recommended Clearance

12" (30.48 cm) on top and 4" (10.16 cm) required in back for air circulation and 4"(10.16cm) at the sides of the unit.

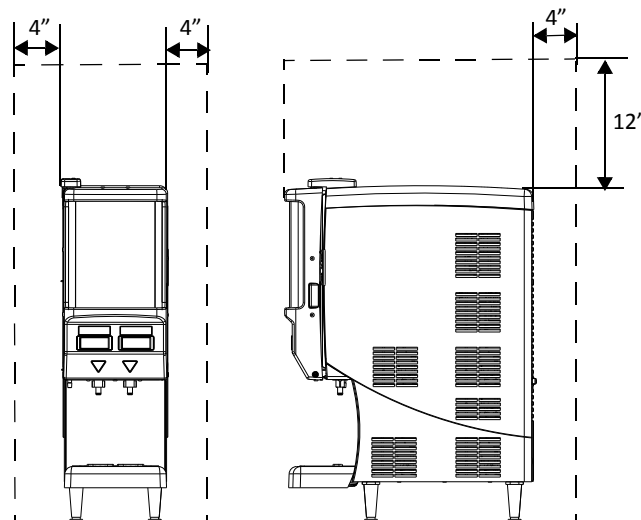

Figure 2.

INSTALLATION

Electrical Connection

6 ft. long (1.83 m) power cord with 3-prong plug attached to dispenser. Export models are shipped with a European plug. The plug is accessible after installation

⚠ CAUTION:

Only trained and certified electrical technicians should replace the power cord or the unit should be returned to an Authorized Service Center for power cord replacement.” The replacement cord must meet all requirements of the original equipment manufacturer.

Failure to comply could result in serious injury, death or damage to the equipment.

Power Supply

10 amps at 230 volts dedicated power supply.

Water Booster System

Install the Water Booster system on the dedicated Quest Elite Water supply line. Preferred location is in the Back Room Area and close to water- gas and/or electricity supply.

Electric Booster Installation Details

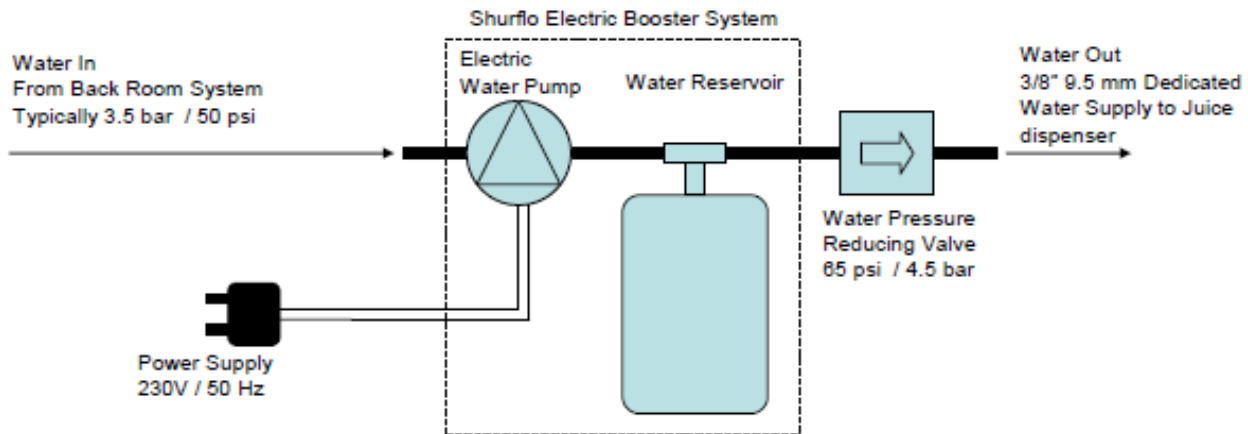

Figure 3.

Gas-operated Booster Installation Details

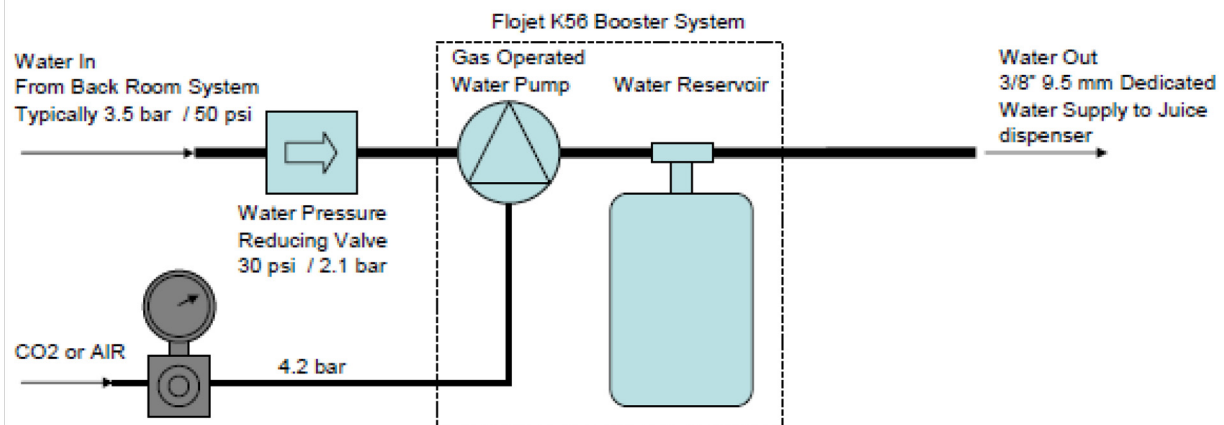

Figure 4.

Booster Installation Notes:

Refer to the OEM manufacturers installation instructions

Boosters and accumulator tanks should be fed with AMBIENT water only. To avoid condensation and premature equipment failure, do not install the water booster assembly in the refrigerated water supply circuit.

To prevent pressure drops in the water supply line, use 3/8" / 9.5 mm ID supply lines only. Limit the amount of flow restrictions s.a. shut-off valves, manifolds and/or fitting.

Water Connection

3/8 in. (0.95 cm) SAE male flare fitting on dispenser (see figure 5).



Figure 5.

The Quest Elite QLT 2000 series Juice Dispensing machine is designed to dispense juice at a high flow rate. It is very important that the incoming water line is dedicated for the unit, or at least does not have other machines connected which could cause a water surge, i.e., a dish washing or coffee machine.

Notes:

The unit should be fed by an insulated chilled water line from the soft drink beverage system. To achieve both optimal brix control and sanitation, assure that the incoming water pressure is at least 60 psi (4.2 bar) dynamic coming from the water booster system.

IMPORTANT: The water supply should be consistent with proper water quality standards (neutral pH of 7.0 to 8.0), and should not be connected to a water softener. It is the installer's responsibility to ensure that all water connections to the dispenser are sized, installed with adequate backflow protection and maintained to comply with Federal, State, and Local Laws.

- A. Secure the 3/8" (0.95 cm) swivel nut on the flexible supply tubing to the water inlet located at the rear of the dispenser. Make sure that the flared gasket is used (flared gasket P/N 311304000 is included with the installation kit).

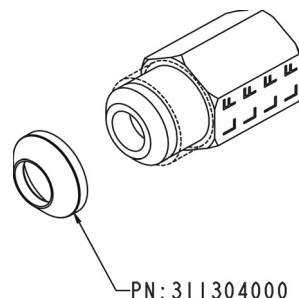

Figure 6.

- B. When securing flare nut, use backup wrench on male side of the inlet fitting (unit side) to prevent twisting of the copper tube inside the unit and/or possible damage to the water strainer/solenoid.

Flushing System

To properly prime the unit with water and remove air pockets in the system, open the cabinet door and make sure the protective dust cap is in place on top of the mixing chamber. Close the door and push the “STOP” Button for a few seconds. Repeat until a steady flow of water is observed.

NOTE: Water splashing may occur during this purge cycle.

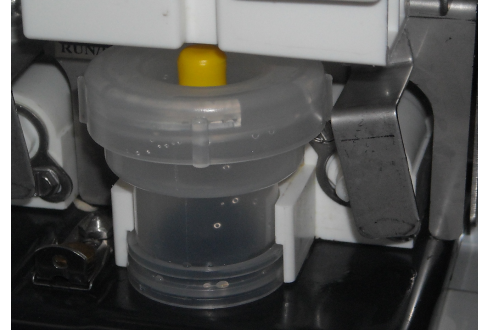

Figure 7.

Filling the Water Bath

1. Remove the Splash Panel (2 screws next to drip tray brackets) .
2. Release filling tube.
3. Remove the red cap.
4. Install the filling tube onto the RH dispense nozzle.
5. Assure that the RH mixing chamber is capped off to prevent the cabinet flooding with water.

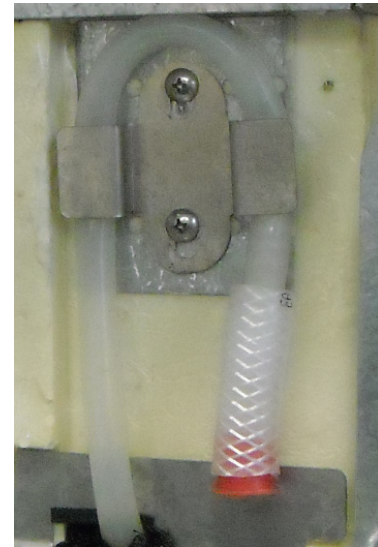

Figure 8.

6. Close the cabinet door, and push the dispenser button – dispense water only
7. Fill the water bath until water evacuates from the overflow
8. Evacuate approx. ½ liter of water. This Eliminates dripping from the overflow when building the ice bank
9. Install the red cap onto the filling tube, and replace into the bracket
10. Allow the cabinet to reach 4°C prior to load any concentrate into the cabinet. This takes approx. 1 hour



Figure 9.

Programming the Portion Control

1. Simultaneously, press and hold “small” and “extra large” push button switches on the Portion Control Module until the “REFILL” light in the corner of the module starts blinking. Release the switches. The blinking light indicates the programming mode is active.
2. Place the cup under the white mixing valve nozzle and push the selected size button (small, medium, large, or extra large). Hold the button in until the cup fills to the desired portion, then release the button. Repeat the above procedure for the remaining sizes.
3. After programming all the drink sizes, press and release the “STOP BUTTON” to return the Portion Control to the operational mode. The blinking REFILL light will go out.



Figure 10.

If in future it is decided to change the portion size of the drinks, the individual sizes can be adjusted by the above procedure. It is not necessary to re-program every size. Additionally the portion control has a full memory retention in case of a power failure.

To pour a drink without using a pre-programmed portion control size, simply push and hold the STOP BUTTON. Release when the glass is full.

Loading With Concentrate Pouches – 6.5 Liters

1. Place the empty pouch holder on its back onto the counter.
2. Grab the pouch by the tube connector and place it vertically on the counter next to the pouch holder.



Figure 11.

3. Locate the silicon tube through the slot, and slide the top of the pouch inwards.
4. Do not pull the silicone tube to guide the pouch into the pouch holder.

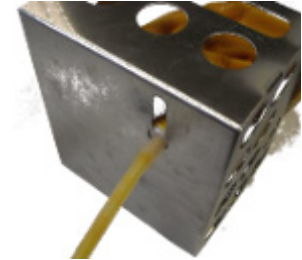

Figure 12.

5. Tilt the pouch holder forward whilst pushing the connector and tube into the proper slot position.



Figure 13.

6. Slide the pouch connector upwards / towards the front of the pouch holder

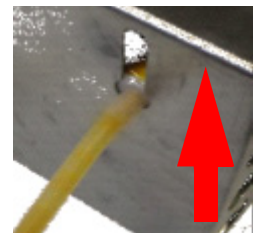

Figure 14.

7. Massage the pouch to fill the pouch holder

NOTE: Improper loading of the pouch into the pouch holder can cause:

- Unable to load the pouch holder into the cabinet.
- Excess remnant.
- Ratio/Brix variations above standards.



Figure 15.

8. Open the Quest Elite Cabinet Door and slide the pouch holder onto the shelf.



Figure 16.

Loading with Concentrate Pouches – 3.0 & 4.5 Liters

1. Place the pouch holder on its side onto the counter. If applicable, first remove the empty pouch and discard.
2. To open, push the sides of container slightly inwards on both sides (see arrows) and simultaneously turn open the lid.

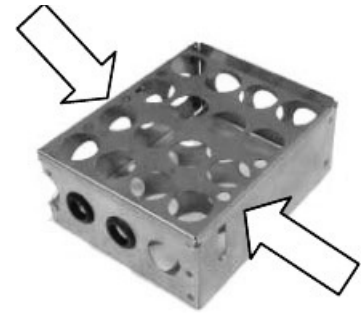

Figure 17.

3. Turn the lid to face upwards or all the way down to the counter.

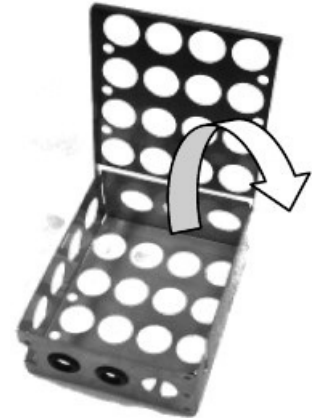

Figure 18.

4. Locate the silicon tube through the slot, and place the pouch into the pouch holder.

NOTE:

- Do not pull the silicone tube
- Load the concentrate pouch properly into the pouch holder
- Avoid concentrate being trapped in the corners



Figure 19.

5. Close the pouch holder lid.



Figure 20.

6. Open the cabinet door, open the QLT pump and slide the pouch holder onto the pouch holder shelf.
7. Locate the silicone tube into the pump and close the pump slide.

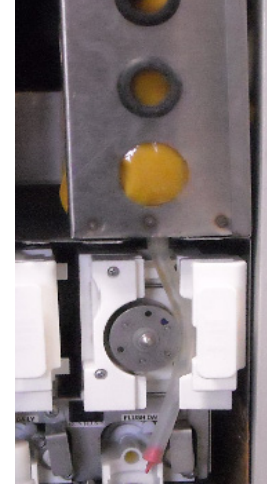

Figure 21.

Connecting the silicone tube onto the Mixing Chamber

1. Remove the Nozzle with the Static Mixer, remove the Mixing Chamber and place onto the drip tray
2. Position the silicone tube into the QLT pump



Figure 22.

3. Close the pump and remove the red stopper from the silicone tube

NOTE:

- Verify that the tube is properly loaded, not jammed between the pump slides
- With single 6.5 liter pouch operation, the left hand valve might be either disabled or used for dispensing still / chilled water



Figure 23.

4. Connect the nipple of the mixing chamber onto the silicone tube
5. Hold the mixing chamber sideways when sliding the nipple onto the silicone tube

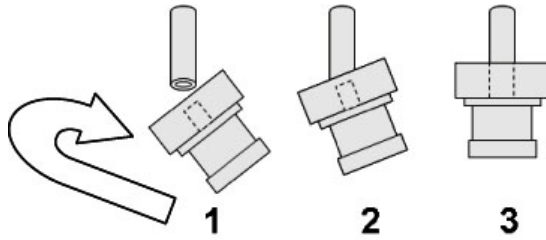

Figure 24.

6. Slide the Mixing chamber in position and push firmly into the pump deck.



CAUTION:

Make sure that the lid of the mixing chamber is properly installed and screwed on tight.

Failure doing so will cause the entire chamber to flood with drinks and eliminating the anti-splattering effect.



Figure 25.

7. Replace the Nozzle and Static Mixer, and close the cabinet door

Priming:

Place a small cup onto the drip tray and press the cancel/Pour button for 2 seconds to prime the mixing system

If only water leaves the nozzle, check if the RUN/FLUSH switch onto the pump platform is placed in the RUN position



Figure 26.

PLANNED MAINTENANCE

Daily – Flushing the system

1. Set both flush switches to “Flush” position.
2. Open the cabinet door. Move both LH and RH flush switches from the “Run” position to the “Flush” position. Close the cabinet door.
3. Place small cold-drink cup under each dispensing nozzle.
4. Place a small, empty, cold-drink cup on the drip tray under the nozzles.
5. Flush nozzles.
6. Push the Cancel/Pour dispenser switches and hold down for 2 or 3 seconds, until clear water is dispensed from both nozzles
7. Reset the flush switches to “Run” position.
8. Open the cabinet door. Move the flush switches from the “Flush” position to the “Run” position. Close the cabinet door.
9. Clean nozzles and mixers.
10. Turn the nozzle to the left or right ¼ turn and pull down to remove the nozzle and static mixer. Take the nozzles and static mixers to the three-compartment-sink. Rinse both with hot tap water to remove any pulp.
11. Replace nozzles and mixers.
12. Reinstall the nozzles and static mixers on the dispenser.



Figure 27.

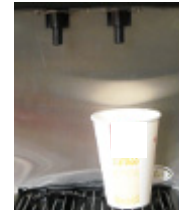

Figure 28.

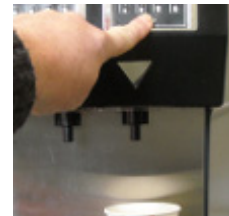

Figure 29.



Figure 30.



Figure 31.



Figure 32.

13. Clean outside of cabinet.
14. Wipe down the outside of the cabinet and the splash panel with a cleaned towel. Place the towel in the soiled towel bucket.



Figure 33.

Weekly – Sanitizing Dispense Parts

1. Perform the DAILY Cleaning Procedures
2. Disconnect mixing chambers from concentrate pouch tubes and remove mixing chambers.
3. Remove the chambers by pulling it firmly toward you.

NOTE: Do not open the pump while the concentrate tube is disconnected from the mixing chamber.



Figure 34.

4. Disassemble the mixing chambers
5. Screw off the lids counter-clock-wise from the mixing chambers bodies prior to sanitizing.



Figure 35.

6. Wash, rinse, and sanitize mixing chamber, nozzle, and static mixer.
7. Wash the mixing chamber, nozzle, and static mix at the three-compartment-sink. Be sure all pulp is removed. Rinse with hot tap water and sanitize the parts.



Figure 36.

8. Reassemble the mixing chambers and reconnect to concentrate pouch tubes.
9. Reinstall the parts in the juice dispenser.



Figure 37.

10. Reinstall nozzles and static mixers.
11. Reinstall the parts in the juice dispenser.
12. Clean outside of cabinet.
13. Wipe down the outside of the cabinet and the splash panel with a cleaned towel.



Figure 38.

14. Dispense a small portion juice to prime the mixing chambers.
15. Press the dispense button to fill a small cold-drink cup with juice. Discard the juice.

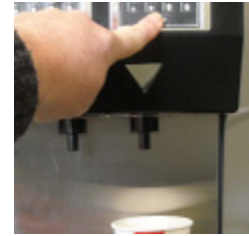

Figure 39.

Weekly – Check Ratio (Prodecure)

1. Turn the nozzles to the left or right ¼ turn and pull down to remove the nozzles and static mixers.



Figure 40.

2. Disconnect mixing chambers from concentrate pouch tubes and remove mixing chambers.
3. Remove the mixing chambers by pulling firmly toward you.

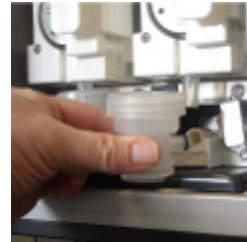

Figure 41.

4. Check the concentrate supply

NOTE: Assure that the concentrate pouch is not near empty, properly loaded into the pouch holder and that the silicone tubes are properly installed into the pumps

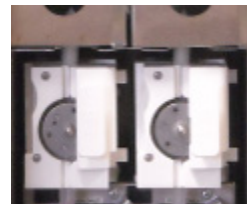

Figure 42.

5. Install the QLT syrup splitter assembly and connect the silicone tube onto the syrup tube.
6. To prevent incorrect ratio readings, do not pull or stretch the silicone tube while connecting to the splitter tube.



Figure 43.

7. Close the cabinet door, place a medium cup onto the drip tray and under the splitter tubes and push the Cancel/Pour button for 1 second to prime the splitter tube and fill with concentrate



Figure 44.

8. Place the RVC onto the drip tray and the water and concentrate chambers locating under the splitter tubes



Figure 45.

9. Dispense Water and Concentrate into the RVC
10. Push the Cancel/Pour button until approx. 300 ~ 350 ml of water has dispensed into the RVC water chamber.



Figure 46.

11. Read the RATIO from the RVC
12. Place the RVC onto a flat surface and read both water and syrup volumes.

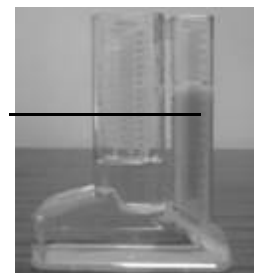

Figure 47.

13. Calculate the Water to Concentrate Ratio.
14. With standard Orange Juice, the Ratio 5 to 1 with a maximum of 5.2 and a minimum of 4.8.
15. Ratio too low: Increase water flow.
16. To correct too low ratio, increase the water flow.
17. Turn the water flow control screw to the right (clockwise) ¼ turn. Check the Ratio again by repeating above steps with a new sample in the RVC.

$$\text{Ratio} = \frac{\text{Water ml/}}{\text{Concentrate ml}}$$

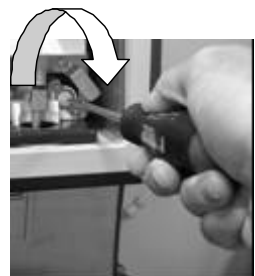

Figure 48.

18. Ratio too high: Reduce water flow.
19. Turn the water flow control screw to the left (counterclockwise) ¼ turn. Check the Ratio again by repeating above steps with a new sample in the RVC.

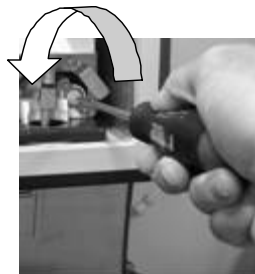

Figure 49.

20. Replace the mixing chambers and reconnect to concentrate pouch tubes.
21. Reinstall the parts in the juice dispenser.
22. Sanitize the syrup splitter and put aside in a safe and clean location



Figure 50.

Monthly - Clean the Air Condenser Filter

1. Pull the magnetic filter off the rear panel of the juice dispenser.



Figure 51.

2. Clean the filter in a bucket of warm soapy water.



Figure 52.

3. Place the filter on a clean, sanitized towel to allow it to air dry.



Figure 53.

4. Place the filter on the rear panel of the juice dispenser.

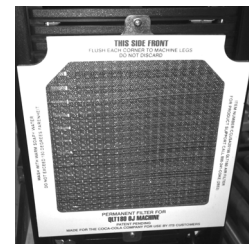

Figure 54.

Semi-Annually - Clean the Water Inlet Strainer

1. Pull the AC plug from the wall outlet

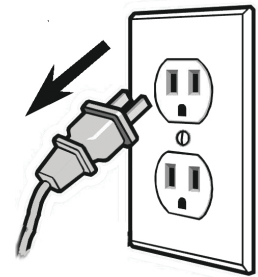

Figure 55.

2. Remove the right side panel from the dispenser.
3. Turn off the water supply to the dispenser.
4. Remove the access port from the “Y” shaped water inlet solenoid located on the right side of the dispenser.
5. Clean and reinstall the stainless steel water strainer.

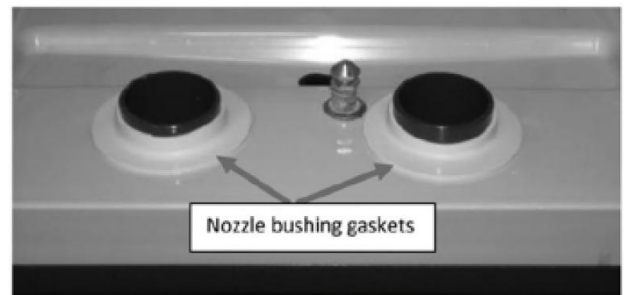

Figure 56.

Annually - Cleaning the cabinet

The cabinet bottom surface and walls should be inspected and cleaned annually following the instructions below.

1. Remove natural rubber nozzle bushing gasket and inspect it and Silicone RTV. If cracked, clean off RTV and re-apply using kit P/N 729011013 per instructions provided with the Kit.
2. Re-apply nozzle bushing gaskets so that the edges lie flat on the floor of the cabinet.
3. Clean the cabinet floor and walls of any spilled juice and let dry. Use a mild soap/detergent and plain water.
4. Re-install the pump platform in the reverse order given above.



For more information, refer to the Planned Maintenance Cards found in the Appendix of this Manual.

Daily maintenance tasks

BE 20 D1 Flush orange juice system.

Weekly maintenance tasks

BE 20 W1 Sanitize orange juice system.

BE 20 W2 Check orange juice Ratio.

Monthly maintenance tasks

BE 20 M1 Clean condenser filter.

TROUBLESHOOTING GUIDE

The following tables contain trouble-shooting information intended to aid an experienced service person in diagnosing operational problems that may occur. For further assistance, contact the Cornelius Customer Services department at 800-238-3600 between the hours of 7:30A.M. and 5:00P.M. Central Standard Time. You must have the model and serial number (Located on the right side of the dispenser) when calling.

Symptom	Probable Cause	Remedy
Unit totally inoperative	<ul style="list-style-type: none"> A. No power to dispenser due to tripped circuit breaker. B. Loose or broken power supply connection inside dispenser. 	<ul style="list-style-type: none"> A. Reset circuit breaker. Confirm that breaker is correct size & no other equipment is operating on the same circuit. Also confirm that supply voltage is +/-10% of nameplate specification. B. Repair connection.
No Cooling	<ul style="list-style-type: none"> A. Line voltage not within nameplate specification causing compressor overload to trip. B. No water in water ice bath or water level extremely low, exposing ice bank sensing probe. C. Defective Ice Bank Control or sensing probe. D. Cabinet fan inoperative resulting in warm concentrate (water continues to cool). E. Compressor short cycles on overload. F. Compressor starts but hums & trips overload. G. Defective compressor overload or start capacitor. H. Compressor starts but does not switch off of start winding. I. Refrigerant leak. 	<ul style="list-style-type: none"> A. Contact an electrician. B. Fill ice bath to proper water level. C. Replace. D. Replace. E. Excessively high discharge pressure due to restricted condenser or inoperative condenser fan motor. F. Seized or shorted compressor, replace. G. Test & replace. H. Relay or compressor is defective. Test & replace faulty item. I. Repair leak, evacuate & recharge system.
No water dispensed, concentrate only	<ul style="list-style-type: none"> A. No water in dispenser. B. Water supply line inside refrigerated cabinet disconnected from pump platform. C. Water solenoid located on pump platform clogged or defective. D. Main water solenoid/strainer located at the rear of dispenser is clogged, binding or defective. E. Water supply pressure is greater than 80 psi (5.5 bar) forcing BRIX flow control closed. F. Freeze-up of water coil in ice bath. 	<ul style="list-style-type: none"> A. Restore water. B. Reconnect C. Disassemble & clean solenoid. Replace if necessary. D. Remove & clean strainer. Confirm 24VDC is present at solenoid during dispense. Confirm solenoid coil is not open. Disassemble & clean solenoid. E. Add external regulator & lower pressure to 50 psi (3.5 bar). F. Unplug dispenser & allow 2-4 hrs. to thaw. Check operation of agitator motor & ice bank control. Refrigeration system may be low on charge resulting in a deformed ice bank & freeze-up of water coil in ice bath.

Symptom	Probable Cause	Remedy
No water & no concentrate, refrigeration is working.	<ul style="list-style-type: none"> A. Black service switch located on the rear of the cabinet door in OFF position. B. White door switch open C. 6.25 amp fuse inside front electrical box blown. D. No output from transformer. E. Defective voltage regulator board (VRB) located inside front electrical box. F. Defective dispense push button or portion control board. 	<ul style="list-style-type: none"> A. Turn on switch. B. Door switch must be closed in order to dispense. Check switch operation & replace if necessary. C. Replace with 6.25, 250VAC slow blow fuse & test. D. Confirm transformer output of 24VAC +/-2. Replace transformer if necessary. E. Measure across the VDC output of the board. There should be 28VDC present when the dispense button is pressed. Replace VRB if necessary. F. Test & replace if necessary.
No concentrate dispensed, water only.	<ul style="list-style-type: none"> A. Concentrate container not fully engaged into receptacle on pump platform. B. Dispense/Flush lever in FLUSH position C. Concentrate too cold, not properly thawed. D. Defective pump motor. 	<ul style="list-style-type: none"> A. Refer to Concentrate Loading section of this manual. B. Move lever to DISPENSE position C. Concentrate should be 35 to 40°F (1.7 to 4.5°C) prior to loading. D. Replace pump motor.
Warm drinks	<ul style="list-style-type: none"> A. Ambient air around dispenser is too warm. B. Excessive demand on dispenser. C. Dirty condenser coil. D. Inoperative condenser fan. E. Defective Ice Bank Control. F. Loss of refrigerant charge due to leak in system. 	<ul style="list-style-type: none"> A. Relocate dispenser. B. Add water pre-cooler or second dispenser C. Clean condenser coil. D. Replace condenser fan motor. E. Test & replace if necessary. F. Repair leak and recharge system.
Water continuously drips from nozzle in OFF mode.	<ul style="list-style-type: none"> A. Main water solenoid at base of unit or water solenoid on pump platform not shutting off completely. 	<ul style="list-style-type: none"> A. Clean solenoid(s), replace parts as necessary (refer to Planned Maintenance section).
Concentrate warm, water cold.	<ul style="list-style-type: none"> A. Cabinet fan inoperable. B. Agitator motor/pump inoperable or restricted. C. Loss of refrigerant charge due to leak in system. 	<ul style="list-style-type: none"> A. Check/replace fan. B. Check/replace agitator motor. C. Repair leak & recharge system.
BRIX problem	<ul style="list-style-type: none"> A. Water supply pressure too low, less than 20 psi (1.4 bar) flowing water pressure. B. Water flow control binding or spring is defective. C. Improperly thawed concentrate. BRIX changes as concentrate temperature changes (concentrate becomes thinner as temperature rises) 	<ul style="list-style-type: none"> A. Correct water supply problem to ensure a constant 50 psi (3.5 bar) flowing to dispenser. B. Clean and/or replace parts as necessary. C. Concentrate should be 35 to 40°F (1.7 to 4.5°C) prior to loading.

Symptom	Probable Cause	Remedy
Pump inoperative	<p>A. Pump motor defective.</p> <p>B. No power to transformer or no 24VAC output from transformer.</p> <p>C. Defective voltage regulator board (VRB) located inside front electrical box.</p> <p>D. Defective dispense control board (Push button or portion control).</p>	<p>A. 28VDC should be present at pump motor during dispense. If voltage is present & motor does not start, replace motor.</p> <p>B. Confirm transformer has line voltage present on primary side. If no 24VAC output from secondary, replace transformer.</p> <p>C. Confirm board produces 28VDC present when dispense button is pressed (refer to Electrical Box Wiring Diagram for VDC output location). Replace VRB if necessary.</p> <p>D. Test & replace if necessary.</p>
Machine continues to dispense after dispense button is released or dispenses without operator input.	<p>A. Push button or portion control pad stuck in ON position.</p> <p>B. Relay on voltage regulator board (VRB) stuck on.</p>	<p>A. Disconnect wire harness from rear of portion control and close the door. If unit does not dispense on its own, dispense control board is bad (stuck on).</p> <p>B. Disconnect 4-wire harness from lower right corner of VRB. If unit continues to dispense on its own VRB is defective (relay stuck on).</p>
Water leaking from the cabinet through the cabinet drain into the drip tray.	A. The O-ring from the cabinet quick connector might be damaged or missing.	A. Replace the O-ring

WIRING DRAWING FOR QUEST ELITE QLT-2000

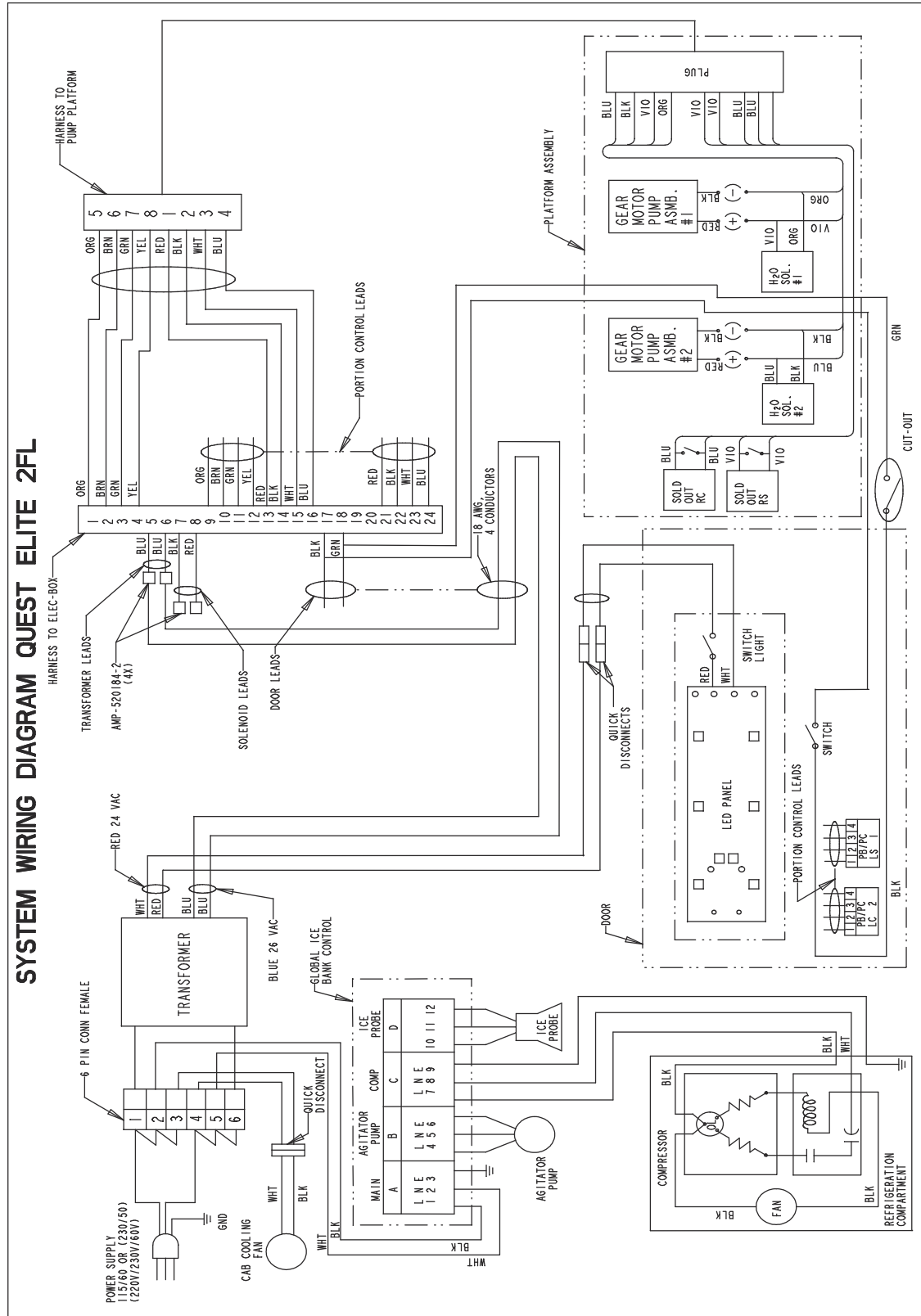

Figure 57.

MAIN ELECTRICAL BOX DIAGRAM

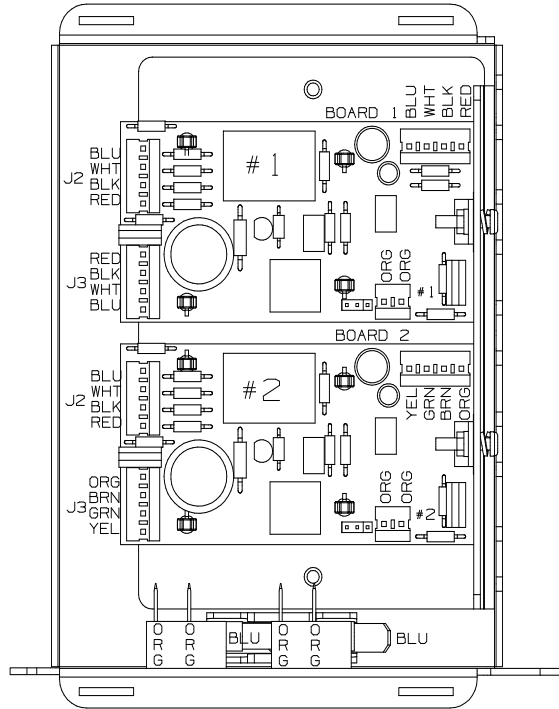

Figure 58.

PIN#	COLOR	SIGNAL	NAME	BOARD#
1	ORG	P1-4	P2(+)	2
2	BRN	P1-3	P2(-)	2
3	GRN	P1-2	SOL2(+)	2
4	YEL	P1-1	SOL2(-)	2
5	BLU	FUSE-S		
6	BLU	P2-4	POWER	1,2
7	RED	P2-1	H20+	1,2
8	BLK	P2-2	H20-	1,2
9	ORG	P3-4	SW2+	2
10	BRN	P3-3	2LED-	2
11	GRN	P3-2	2LED+	2
12	YEL	P3-1	SW2-	2
13	RED	P1-4	P1(+)	1
14	BLK	P1-3	P1(-)	1
15	WHT	P1-2	SOL1(+)	1
16	BLU	P1-1	SOL1(-)	1
17	BLU	FUSE-R		
18	WHT	P2-3	POWER	1,2
19				
20				
21	RED	P3-4	SW1+	1
22	BLK	P3-3	1LED-	1
23	WHT	P3-2	1LED+	1
24	BLU	P3-1	SW1-	1

ELECTRICAL BOX WIRING, QLT P/N 720901002

Figure 59.

QLT 2000 FINAL ASSEMBLY

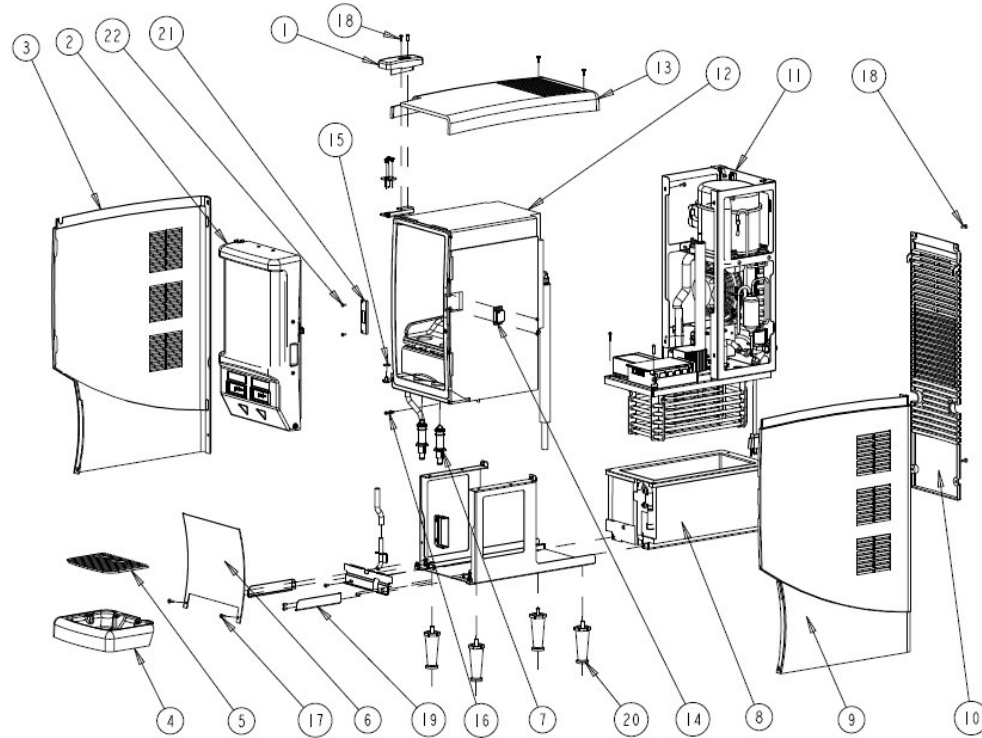

Figure 1.

Item	Part No.	Description
1	620047969	Hinge Top Cover, Quest Elite 2/4 FL
2	620047744	Merchndsr Assy Qst2 2FL
3	620054876	Side Panel LH. Quest Elite 2/4 FL
4	620049855	Drip Tray, Black W/Texture, Quest Elite 2 FL
5	620708562	Cup Rest W/LOC Quest 2 STND 8.1 X
6	620048648	Splash Panel Guard, Quest Elite 2 FL
7	620715835	Nozzle Static Mixer ASMB
8	620049092	Tank Foamed Qste Finish 2FL
9	620054875	Side Panel RH. Quest Elite 2/4 FL
10	620050923	Rear Panel, Quest 2 FL
13	620048898	Top Panel W/Cut, QST Elite 2 FL
14	720704004	Door Catch, Female 2FL / 4FL
16	620049566	Washer- Hinge Bottom QST Elite 2/4FL
17	620047782	Pin Latch Cabinet Qst2 2FL/4FL

Item	Part No.	Description
18	0704105	Screw MA #8-32 TRPH 16 SS
19	70178	Screw MA #8-32 TRPH 16 SS
20	620047429	Brkt, Drip Tray, Right, QST 2/4 FL
	620047428	Brkt, Drip Tray, Left, QST 2/4 FL
21	37958	Leg Level 4"
22	720201440	Brkt, Catch Strike Plate QST-NT
23	720701405	Screw TB D6-18 PAPH 12 SS
24	620048922	Kit Literature Pkg QST 2FL (not shown)
25	620048649	Label System Wiring Diagram QS
26	620047943	Harness Door, QST2, 2FL (not shown)
27	620048959	Harness to Power Cord QST2, 2/4FL (Not Shown)
28	11732	Harness Assembly Platform SLJ 1000 (Not shown)
29	620049320	Harn Combined Compressor Condenser QST Elite 2/4FL (Not Shown)

QLT 2000 DOOR ASSEMBLY REFERENCE (PUSHBUTTON & PORTION CONTROL)

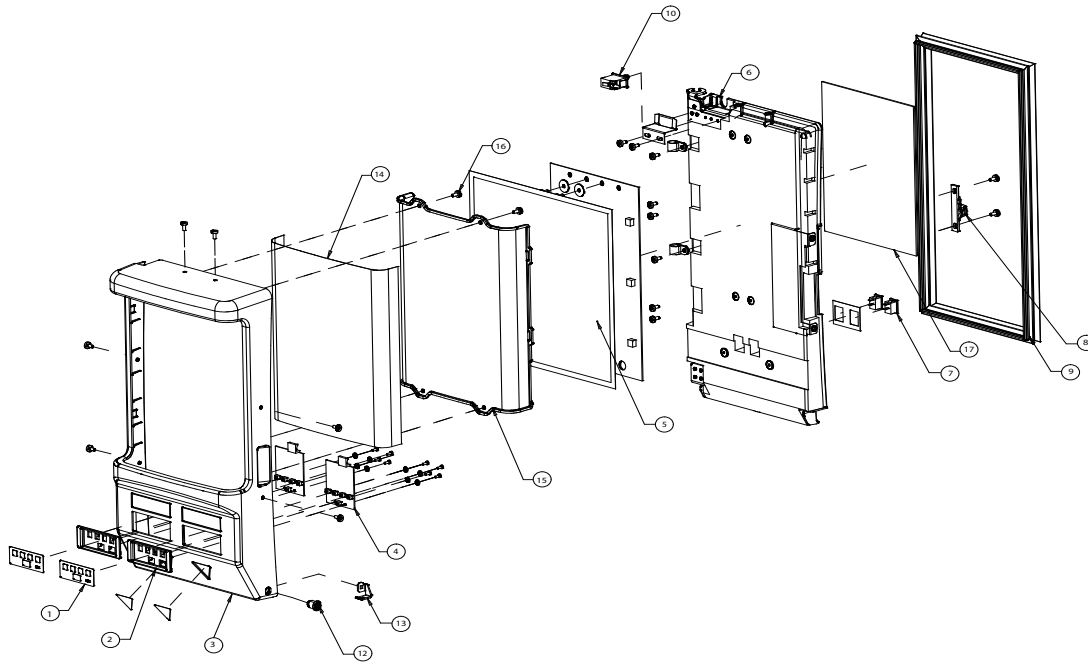

Figure 2.

Item	Part No.	Description
1	620047753	Overlay Assembly, Pushbutton Control, Quest
	620047750	Overlay Assembly, Portion Control, Quest Elite, 2/4
2	620047751	Bezel, Push button, Silver, Quest Elite, 2FL /4FL
	620047968	Bezel, Portion Control, Silver, Quest Elite, 2FL /4 L
3	620047745	Merchandiser, Quest Elite, 2FL
4	45018001	Board Push button SLJ
	49280001	Board Portion Control SLJ
5	620047679-100	LED Quest PCBA Backlight Family
6	620047754	Assembly, Door Foamed, Quest Elite, 2FL
7	620051427	Switch Rocker Unmarked Qste 2FL/4FL
8	720704005	Latch Door Male
9	620047759	Seal, Door, Quest Elite, 2FL
10	720500713	Switch Cut off 10 A MOM E6900A
11	620049097	Label Triangle Nozzle Indicator Mirror Finish QST2 2FL/4FL

Item	Part No.	Description
12	729011214	Kit, Lock & Key Door Quest Elite 2FL/4FL
13	620047748	Latch Mounting Lock
14	620047761-26	Graphics Merchndsr MM Europe Qste 2FL
	620047761	Graphic- Merch Generic QST2 2FL
15	620047760	Lens, Quest Elite, 2FL
16	0704101	Screw MA 8-32 TRPH 12 SS
17	620052150	Label Daily Flush & Cleaning Quest Elite Qlt
	620052151	Label Daily Flush & Cleaning SLJ Flush
	620052153	Label Daily Cleaning QSTE Non Flush
18	629097007	Kit 1, Flavor Strip Quest Elite, 2/4FL (Not shown)
	629097008	Kit 2, Flavor Strip Quest Elite, 2/4FL (Not shown)
19	729011218	Kit, Conversion PB to PC, QSTE 2FL (Not Shown)
	729011219	Kit, Conversion PC to PB, QSTE 2FL (Not Shown)
NS	620050925	Label Rocker Switch Details, Qste,230v, 2/4FL

CABINET ASSEMBLY REFERENCE

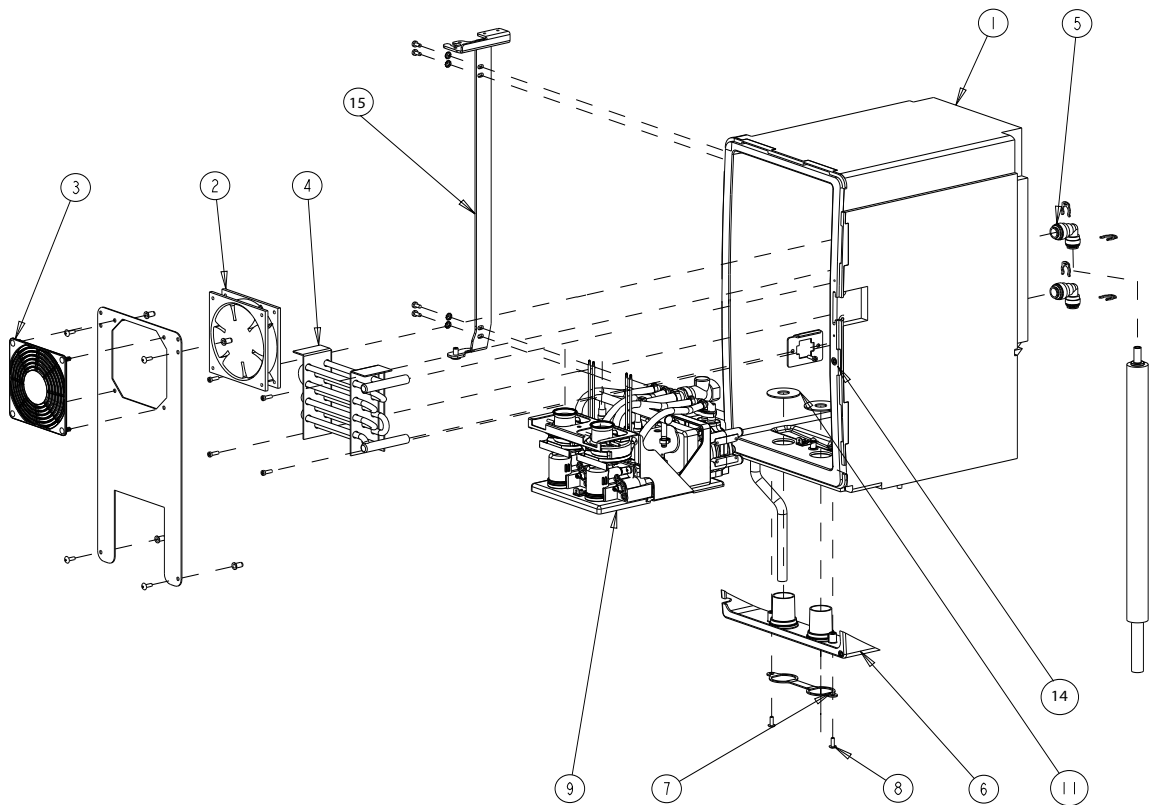

Figure 3.

Item	Part No.	Description
1	620049842	Cabinet Assy QST Elite 2FL Modified Drain
2	720506104	Fan Assembly 115/60/50 4.7 X 4.7X1.0
	720506105	Fan Assembly 230/50/60 4.7 X 4.7 X1.0
3	620047512	Guard, Fan EBM 9000 & 4000
4	620049556	Cabinet Heat Exchanger, Quest Elite, 2FL
5	720509206	Fitting Push, Union Elbow, 3/8"X 1/2" LG

Item	Part No.	Description
6	620047970	Trim Bottom W/Insert, Quest Elite, 2FL
7	720201479	Bracket Dual Nozzle Block Quest
8	07040007	Screw Machine, #8-32 PAPH 28SS
9	720522100X	Platform Asy Qlt Qst 2000
11	S3354	Gasket Sealing Bowl Spout
14	720200206	Fitg Insr 3/8"NPT PP
15	620047775	Brkt Hinge QST2 2FL/4FL

TANK COVER ASSEMBLY

P/N 620047892

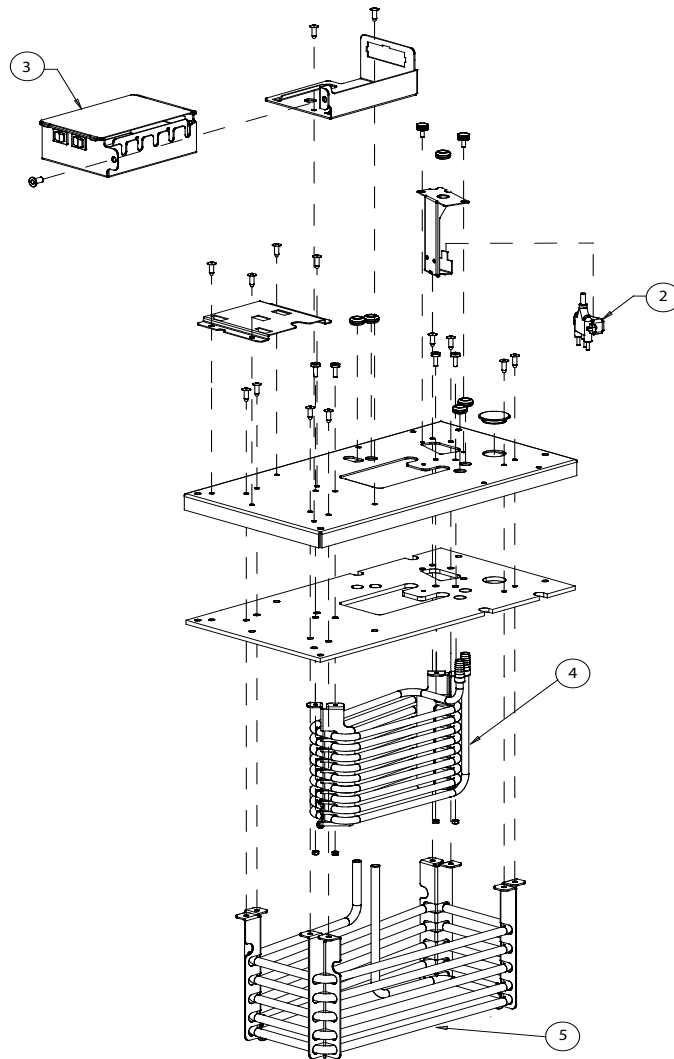

Figure 4.

Item	Part No.	Description
2	729011222	Kit Service Ice Probe Assy QSTE 2FL
3	720521000	Box Elec Asy Dc QST2 QLT

Item	Part No.	Description
4	720501502	Coil, Water, QUEST 2, 2FL
5	620049563	Coil, Refrigeration QUEST Elite 2FL

REFRIGERATION FRAME ASSEMBLY QLT 2000

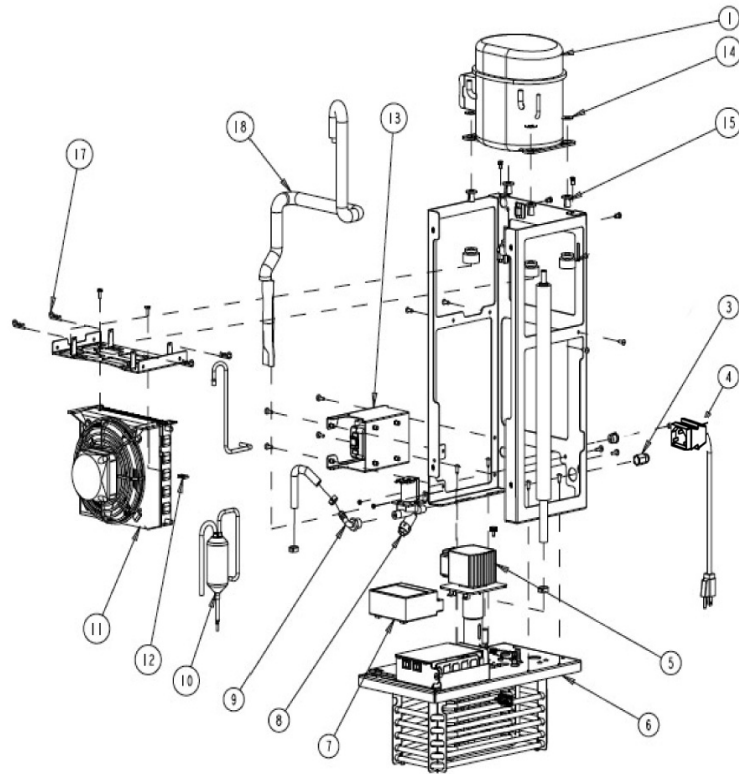

Figure 5.

Item	Part No.	Description
1	729011215	Kit, 115V Compressor & Filter Dryer
	729011216	Kit, 230V Compressor & Filter Dryer
	729011217	Kit 220V Compressor & Filter Dryer
3	620048659	Adapter, 1/4" FPT x 3/8" MF
4	620049959-001	Cord Power Straight IEC60320-C13 Family
	620049959-003	Cord, Service 230V
	620049959-007	Cord Serv 200V 60 HZ IEC 60906-1
	620049959-008	Cord Pwr ME Version QSTE 2/4FL
	620049959-009	Cord PWR QSTE 2/4FL Cei-16/Vii Italian Plug
5	620042742	Agitator Motor Assembly 115V
	620042741	Agitator Motor Assembly 230V
6	620047892	Tank Cover Assembly, Quest Elit, 2FL
7	729011138	Kit GIBC Field Quest (Not Shown)
	440000901	Control Ice Bank 230V Global
	440000902	Control Ice Bank 120/60 QST

Item	Part No.	Description
8	620047891	Valve Water W/Solenoid, Quest Elite, ? 2/4FL
9	620049857	Reducer, Elbow, 1/4" FPT x 3/8" Barb
10	620047114	2 Cubic Inches, Filter Dryer
11	560004366	Fan Axial Small
	560003706	Fan, Condenser Assembly, 230V, Quest Elite 2FL
	560004360	Motor- Fan 08W 120/60 Service
	560004368	Grille Cond Fan Small
12	560004364	Shroud Cond Olympus Small
	6775	Clip Tin CB14-832-4
13	620047655	Transformer, 115V, Quest Elite 2/4FL
	620047654	Transformer, 230V, Quest Elite 2/4FL
14	9649	Washer Comp Mount
15	317781000	Bushing, Split
17	08474	Clip Spring
18	620051406	Suction HX Assembly, Quest Elite 2FL

PLATFORM ASSEMBLY QLT

P/N 720522100X

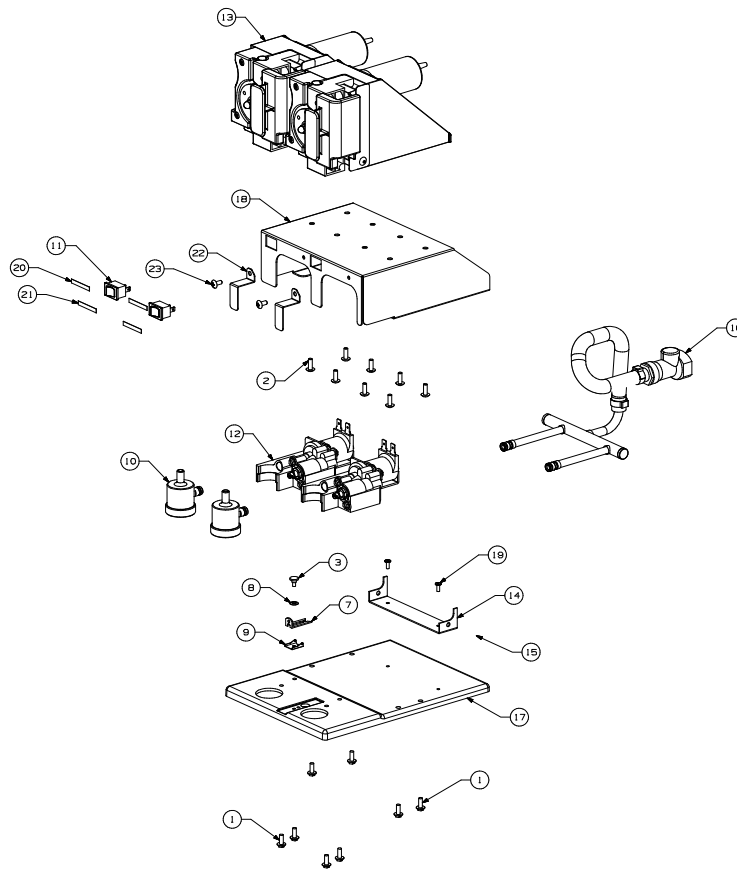

Figure 6.

Item	Part No.	Description
1	07032001	Screw #8-18X 7/16 Type 25 HHW
2	0704105	Screw MA #8-32 TRPH 16SS
3	720701001	Rivet Platform Base Quest
4	11877	Jumper Assembly Read Flush QLT 180(Not Shown)
5	11887	Jumper Assembly Red Flush Switch AL (Not Shown)
6	11888	Harness Assembly Platform SLJT1000-2(Not Shown)
7	45046	Latch #2 Medium SS
8	45047	Guide Latch #2 MED
9	45048	Washer Latch #2 MED
10	45364001X	Chamber Mixing Assembly QLT 180 Day

Item	Part No.	Description
11	45432	Switch Rocker Sealed
12	45508200X	Valve Block Assembly QLT Generic
13	45514100X	Pump Assembly QLT 180
14	45542	Manifold Bracket QLT 180 2 FLAV
15	55145	Wrap, Tye 5 1/2 inch Long (Not Shown)
16	720509312	Manifold Assembly Water QLT/QST2
17	720520301	Base Platform QLT QST2
18	720522011	Bracket Support Platform QST2
19	7245541	Label Run Flush QLT 180
20	7245821	Label Clean
21	720501429	Bracket Water Adjustment Cover QS
22	07115001	Screw TF 8-32 TRPH 12SS

VALVE BLOCK ASSEMBLY

P/N 45508200X

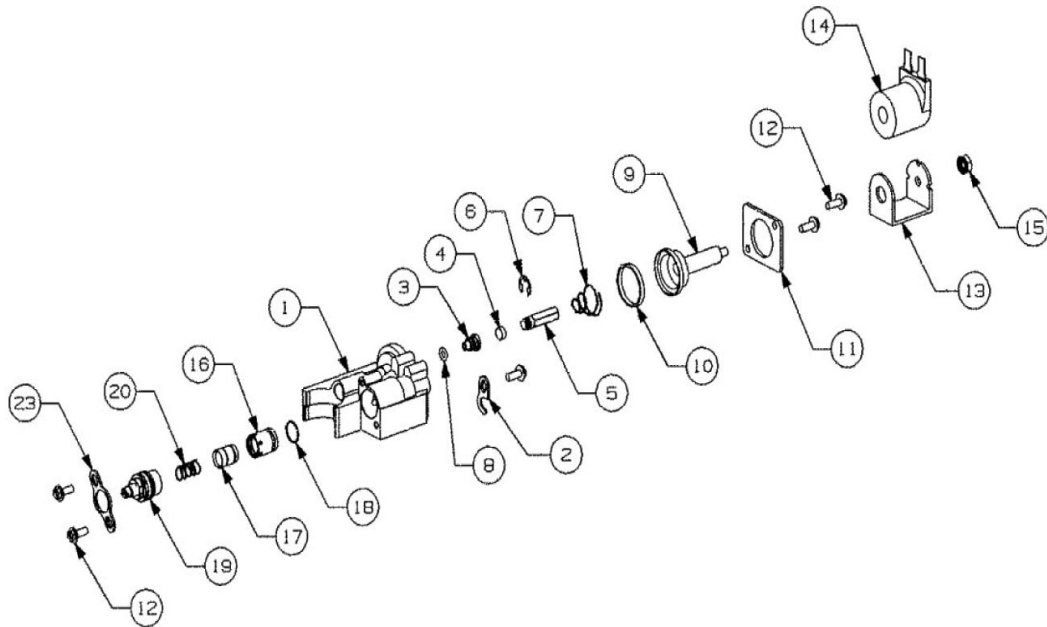

Figure 7.

Item	Part No.	Description
1	45506100	Valve Block
2	45586	Hold Down Washer
3	49612	Valve Port, Water
4	620711131	Seal Armature - Water Side
5	71860290	Armature
6	71815321	Retaining Ring, 0.242 ID
7	18367	Coil Spring, SS
8	31525020	O-Ring 5/16" OD X 0.176 ID
9	19695001	Guide
10	620710107	Gasket FFV/SEV
11	45518	Bracket, Valve Block

Item	Part No.	Description
12	07032001	Screw, #8-18 X 7/16" Type "25" HHWF SS
13	16779003	"C" Frame, Solenoid
14	48520001	Coil, 24VDC
15	0720406	Not #10-32 KEPS
16	60281001	Ceramic Sleeve, Syrup, FFV
17	60280002	Ceramic Piston, Water, FFV
18	31525060	O-Ring 0.539" X0.459" X0.875" OD
*	48979103	Sleeve & Piston Asy Water Ceramic (Include items 16, 17&18)
19	7245699	Flow Control/Bonnet Assembly
20	48258005	Spring, Zero, FFV
23	45587	Hold Down Washer

ELECTRICAL BOX ASSEMBLY

P/N 720521000 (FOR QLT DISPENSERS ONLY)

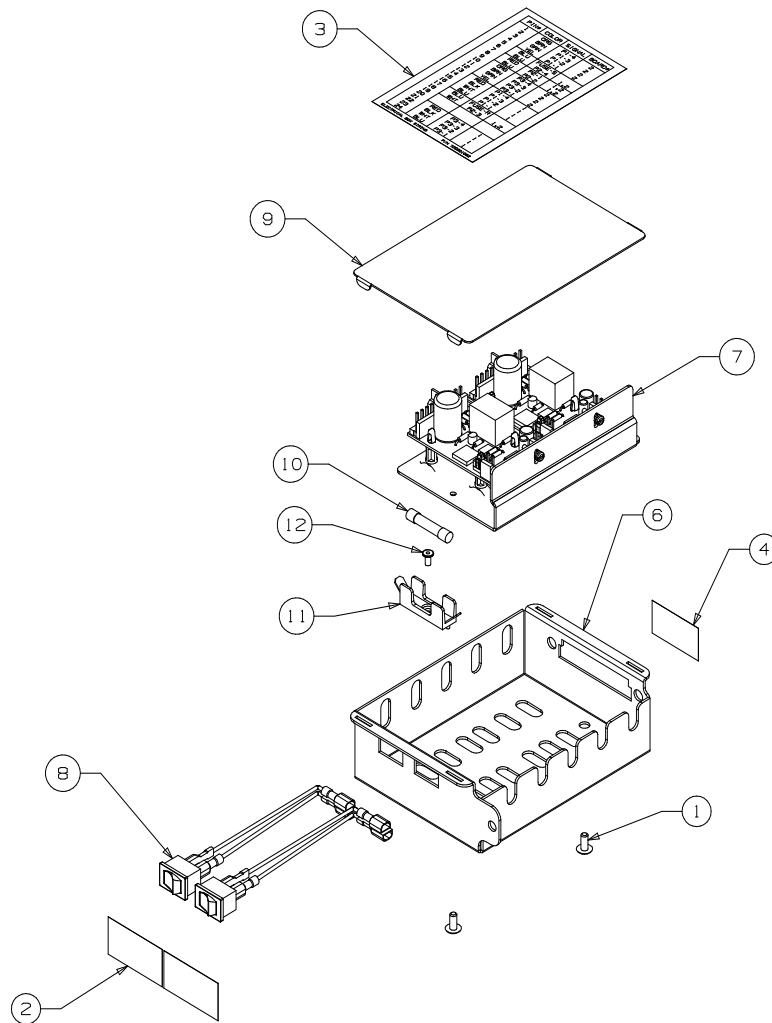

Figure 8.

Item	Part No.	Description
1	07115001	Screw TF, #8-32 TRPH, 12 SS
2	45621	Label Pump Speed Switch
3	720901002	Label Wiring E-Box
4	45758	Label Fuse Rating
5	720522003	Wire Harness Internal Electrical Box QST 2000 QLT
6	720521001	Electrical Box Quest 2000

Item	Part No.	Description
7	720521500	Reg. Voltage Assembly QLT Quest 2000
8	45432001	Rocker Switch Assembly
9	720521201	Cover Electrical Box Quest 2000
10	59328001	Fuse 6.25 AMP 250V SLJ
11	7245059	Fuse Holder
12	734801	Rivet, Pop

POUCH HOLDER ASSEMBLY

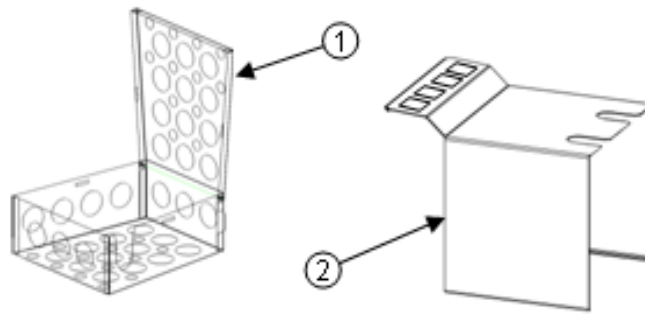

Figure 9.

Item	Part Number	Description
1	620053167	Pouch Holder 6.5 liters – Stainless Steel (for 1 x 6.5 L)
	620053165	Pouch Holder 3.0 liters – Stainless Steel (for 3 + 6 L)
	620053166	Pouch Holder 6.0 liters – Stainless Steel (for 3 + 6 L)
	620053164	Pouch Holder 4.5 liters – Stainless Steel (for 2 x 4.5 L)
2	620051471	Pouch Holder Shelf

RECOMMENDED SPARE PARTS BASED ON 10 UNITS

Qty.	Part No.	Description
1	620042742	Agitator Motor - 115/60 VAC
1	620042741	Agitator Motor - 230/50 VAC
		Agitator Motor - 220/60 VAC
1	620047785	Compressor 115/60 QE 2/4
	620048652	Compressor 220/60 QE 2/4
	620048651	Compressor 230/50 QE 2/4
1	560003706	Cond-Coil & Fan 07W 230/5/6.2
1	560004360	Condenser Fan, Motor 115 VAC
1	560004361	Condenser Fan, Motor 230 VAC
1	560004364	Fan Shroud
1	560004368	Grill Fan
1	560004360	Motor-Fan 08W 120/60 Service
2	18367	Spring, Coil S/S-Water Solenoid
4	45098	Pump Tubing Kit
1	620051427	Switch Rocker Unmarkedv QSTE 2/ 4FL
1	720301104	Switch Rocker Sealed
2	720521500	Voltage Regulator Board, QLT
2	45016001	Pump Dear Motor
1	45026100	Bottle Adapter O-Ring Kit (all O-rings in bottle adapter)
1	45728001	Pump Rotor Assembly
1	48520001	Coil, 24 VDC, Valve Block
2	48979103	Spool & Sleeve Assembly W/31525- 060 O-Ring

Qty.	Part No.	Description
1	440000902	Global Ice Bank Control
1	720520501	Drip Tray Grill
1	720500102	Drip Tray
1	720502800	Agitator Motor
2	720506104	Cabinet Fan, 115VAC
1	620042741	Agitator Motor Assembly 230V/50Hz
1	720507101	Dispense Nozzle, Static Mixer, & O- Ring
1	720508801	Push Button Control Board
2	720508802	Portion Control Board
1	620047654	Transformer 230 V 50/60 VAC QE 2/4
1	620047655	Transformer 120 V 60Hz 26V@4A2
1	620047891	Valve Water W/solenoid QS T2 2/
1	620049856	Drip Tray Black W/texture QS T
1	620047654	Transformer 230V 60 230V 26V@4A2
1	720506104	Fan Assembly 115/60/50 4.7X4.7X1.0
1	620054204	Relay, Comp AEA 3417 YXA, 115V/ 60Hz
1	620054205	Overld,OLP, Comp, AEA 3417 YXA, 115V/60Hz
1	620054206	Relay, Comp, AEA 3417 YXL, 230V/ 50Hz
1	620054207	Overld,OLP, Comp, AEA3417 YXL, 230V/50HZ
1	620054208	Relay, Comp, AEA3417 YXD, 220V/ 60HZ
1	620054209	Overld,OLP, Comp, AEA 3417 YXD 220V/60HZ

Cornelius Inc.
www.cornelius.com

