



VIPER E 2 FLAVOR, R-454C

Installation, Service and Decommissioning Manual



Release Date: TBD

Publication Number: 620073146SER

Revision Date: March 21, 2022

Revision: A

Visit the Cornelius web site at www.cornelius.com for all your Literature needs.

The products, technical information, and instructions contained in this manual are subject to change without notice. These instructions are not intended to cover all details or variations of the equipment, nor to provide for every possible contingency in the installation, operation or maintenance of this equipment. This manual assumes that the person(s) working on the equipment have been trained and are skilled in working with electrical, plumbing, pneumatic, and mechanical equipment. It is assumed that appropriate safety precautions are taken and that all local safety and construction requirements are being met, in addition to the information contained in this manual.

This Product is warranted only as provided in Cornelius' Commercial Warranty applicable to this Product and is subject to all of the restrictions and limitations contained in the Commercial Warranty.

Cornelius will not be responsible for any repair, replacement or other service required by or loss or damage resulting from any of the following occurrences, including but not limited to, (1) other than normal and proper use and normal service conditions with respect to the Product, (2) improper voltage, (3) inadequate wiring, (4) abuse, (5) accident, (6) alteration, (7) misuse, (8) neglect, (9) unauthorized repair or the failure to utilize suitably qualified and trained persons to perform service and/or repair of the Product, (10) improper cleaning, (11) failure to follow installation, operating, cleaning or maintenance instructions, (12) use of "non-authorized" parts (i.e., parts that are not 100% compatible with the Product) which use voids the entire warranty, (13) Product parts in contact with water or the product dispensed which are adversely impacted by changes in liquid scale or chemical composition.

Contact Information:

To inquire about current revisions of this and other documentation or for assistance with any Cornelius product contact:

www.cornelius.com
800-238-3600

Trademarks and Copyrights:

This document contains proprietary information and it may not be reproduced in any way without permission from Cornelius.

This document contains the original instructions for the unit described.

MARMON FOODSERVICE TECHNOLOGIES, INC.
355 KEHOE BLVD
CAROLSTREAM IL
TEL:+1-800238-3600

Printed in U.S.A.

INSTALLATION - TABLE OF CONTENTS

Safety Instructions	1
Introduction	4
System Overview	4
Introduction	4
Dispensed Product Conditions	4
Overrun, as Applied to Carbonated Beverages	4
Installation	6
Delivery, Inspection & Unpacking	6
Counter Location	6
Installing Leg	6
Counter Mounting	7
Countertop Template Installation Instructions	7
Backroom Requirements	8
Supply Connections	8
Electrical Requirements	9
Water Supply Requirements	10
CO ₂ Requirements	11
Installing The Drip Tray	13
Installing The Graphics Sheet	14
Installing The Flavor Card	14
Cart Information and Mounting	14
Servicing Motorman Dispensing Valves	15
Suggested Sanitizers	15
Servicing SPH Dispensing Valves	17
Sanitizing the System	17
Suggested Sanitizers	17
Control Panel Overview	21
Setting Up the Control Panel	21
Setting the System Options	22
Commissioning the Unit	29
Unit Location	29
Pressurizing the Water System	29
Pressurizing the CO ₂ System	30
Pressurizing the Syrup System	31
Setting BRIX	31
Filling the Barrels	34
Calibrating a Motor	34
Security Menu	36
Troubleshooting	37
Specifications	38

SERVICE - TABLE OF CONTENTS

Introduction	43
Manual Overview	43
Dispensed Product Conditions	44
Overrun, as Applied to Carbonated Beverages	44
Overrun Definition	44
Overrun is a Variable	44
Specific Product Ingredients Affect Overrun	44
BRIX Affects Overrun	44
Low Dispensing Volume Affects Overrun	44
Carbonation Level in Liquid Product Affects Overrun	44
Freezing Affects Overrun	44
System Overview	45
Introduction	45
Theory of Operation	45
CO2 System	48
Water System	51
Syrup System	51
Control Panel	51
Introduction	51
Control Panel Display	51
Control Panel Buttons	52
Control Panel Menu Descriptions	54
System Menus	54
Main Menu	54
Unit Data Menu	55
Error Status Menu	55
Error Log Menu	57
Setup Menu	58
Clock Setup Menu	58
Setting the Clock	59
Setting Daylight Savings Time	59
Events Setup Menu	61
Setting Events	61
Setting the Sleep and Wake up Times	61
Setting Defrost Lockout	62
Viscosity Setup Menu	63
Options Setup Menu	63
Setting the Temperature Format	64
Setting the Date Format	65
Setting the Time Format	64
Setting the POS Lighting	64
Setting the Type of Syrup	64

Maintenance Menu	64
Barrel Maintenance Menu	65
Purging a Barrel	65
Filling a Barrel	66
Run the Barrel Motor	66
Rinsing a Barrel	66
Manual Diagnostic Menu	67
Totals Menu	67
BRIX Setup Menu	68
Motor Setup Menu	71
Calibrating a Motor	72
System Menu	72
Security	73
Pressure Sensors	73
Operation	75
Maintaining Product Quality	75
Dispensed Product Throughput	75
Programmed Defrost Scheduling	75
Sleep Mode Recommendations	75
Viscosity Setting	76
Starting the Unit	76
Preventative Maintenance	77
Summary	77
Monthly Maintenance	77
Cleaning Air Filter	77
Annual Maintenance	78
Inspecting and Replacing Scraper Blades	78
Cleaning the Syrup Connections	79
Servicing Motorman Dispensing Valves	79
Suggested Sanitizers	81
Servicing SPH Dispensing Valves	81
Sanitizing the System	80
Suggested Sanitizers	80
Emptying a Barrel	82
Flushing the System of Syrup	82
Sanitizing the Barrel	83
Flushing the System	84
Cleaning the Water Filter	84
Component Replacement	86
Barrel Motor Seal Replacement	86
Removing the Existing Seal	86
Installing a New Seal	87
Motor Seal Leak Test	88
Barrel Motor Replacement	89

Motor Run Capacitor Replacement	89
Water Pump Replacement	90
CO2 Shutoff Solenoid Replacement	91
Syrup and Water Shutoff Solenoid Replacement	92
CO2 Regulator Replacement	93
Condenser Fan Motor Replacement	94
Compressor Replacement	94
Hot Gas Solenoid Replacement	95
Liquid Line Solenoid Replacement	96
Syrup Pressure Switch Replacement	96
Water Pressure Switch Replacement	97
Display Board Replacement	98
Control Board Replacement	98
Backward/Forward Compatibility with Older Software Versions	99
Motor Board Replacement	100
Troubleshooting	101
Troubleshooting the System	101
Troubleshooting Product Not Cold	101

DECOMMISSIONING PROCESS - TABLE OF CONTENTS

Decommissioning Procedure	104
Recovery Requirements and Guidelines	104
Information On Correct Working Procedures	105
Disposal	107

INTRODUCTION

SYSTEM OVERVIEW

Introduction

The Viper system is a state-of-the-art FCB/FUB machine. Viper provides improved drink availability, reliability and reduced complexity in a compact, reduced footprint machine.

Viper provides the highest quality in drink appearance and consistency while keeping operation and maintenance simple and straightforward.

The unit consists of multiple freeze barrels that each contain an internal beater driven by an electric motor, a refrigeration system, a timer-controlled, intelligent defrost system and interconnecting tubing and controls required to dispense the product.

DISPENSED PRODUCT CONDITIONS

Overrun, as Applied to Carbonated Beverages

Overrun Definition

Overrun is defined as product expansion that takes place in the frozen carbonated drink. It is caused primarily by CO₂ gas breakout and secondarily by freezing.

Overrun is a Variable

The percentage or degree of overrun depends on a number of factors. The specific syrup, BRIX, low dispensing volume, carbonation level in the liquid product and freezing of the product. These items all affect overrun. After these factors have been considered, desired viscosity (product consistency) adjustment may be made on the unit. The viscosity adjustment adjusts product texture from very wet to light.

Specific Product Ingredients Affect Overrun

Each syrup has its own specific formulation of makeup. Fruit flavors contain citric acids that colas do not. Colas also differ in ingredients from one brand to another. Each product formulation has its own peculiarities regarding the way the product absorbs carbonation and the way it releases carbonation.

BRIX Affects Overrun

Sugar in carbonated drinks is like anti-freeze in water. The higher the BRIX, the greater the resistance of the product to freezing. Conversely, in products with lower BRIX, freezing takes place at higher temperatures than for high-BRIX products. Thus, BRIX affects overrun because the amount of sugar in a drink has a direct bearing on the product's freezing characteristics.



Figure 1.



Low Dispensing Volume Affects Overrun

When a unit sits idle for a period of time with no drinks being dispensed, CO₂ gas in the system takes a “set”. When the first few drinks are drawn off after an idle period, CO₂ gas has less tendency to break out as the drink is dispensed. The result is that these first drinks have less overrun than drinks dispensed during peak-use periods.

Carbonation Level in Liquid Product Affects Overrun

The higher the specific carbonation level in a given product, the greater the potential for carbonation breakout in frozen carbonated form of that drink. For example, drinks with 3.0 volume of carbonation have more gas breakout in frozen carbonated form and more overrun than drinks that contain 2.0 volumes of CO₂ gas.

Freezing Affects Overrun

Freezing causes approximately a 5-7 percent expansion in dispensed frozen carbonated drinks. The degree of freezing is limited because the finished drink is intended to be sipped through a straw. This is not possible if the product is too “solid”.

INSTALLATION

DELIVERY, INSPECTION & UNPACKING

NOTE: Cornelius is not responsible for damaged freight. If damage is found, you must save all packaging material and contact the freight carrier. Failure to contact the carrier within 48 hours of receipt may void your claim.

1. Inspect the carton and note any damage, regardless if it appears minor. If the carton is damaged, note on the consignee copy of the freight invoice "exterior carton damage – concealed damage possible" and contact the freight company immediately.
2. Remove any staples along the bottom edge of the carton and lift the carton off the pallet.
3. Remove the exterior carton sleeve, internal fillers and plastic bag around the unit. Carefully inspect the unit for damage.
4. Remove the bolts holding the dispenser to the pallet.
5. Remove the packing fillers from the top of the unit.
6. Inspect the dispenser cabinet and make sure it has no scratches, dents or any other cosmetic defects.
7. Make sure that the glass or plastic merchandiser panels are not scratched or cracked.
8. Open the packages of loose parts and inspect all of the parts for damage or missing parts. Check the parts received against the packing list to insure receipt of all parts.

NOTE: If unit is installed more than three months from date of production, replace the seals according to the instructions accompanying the spare seals supplied with the unit. Unit date of manufacture is included in the unit serial no. as follows: The date code follows the first letter of the serial number. The next four numbers reflect the date of manufacture. The first two represent the year, the next two the week. For example, 62A0815xxxxx would be a unit produced during the 15th week of 2008.

COUNTER LOCATION

Select a location in a well ventilated area, close to a grounded electrical outlet and backroom connections. The counter must be capable of supporting a minimum of 450 pounds. If possible do not place the unit close to hot and/or steaming machines.

The minimum clearance is: 2 in. (5.08 cm) in back and 12 in. (30.48 cm) on top of the unit. If both sides have a minimum clearance of 2" (5.08 cm), then the unit may be flush to the wall in the back.

If a Viper unit is installed in ambient temperature conditions of greater than 95°F, keep the following minimum clearances for proper functioning: 2" (5.08cm) at the rear, 17" (43.18 cm) on the sides, and 27" (68.58cm) at the top.

This appliance is not intended for use by persons (including children) with reduced physical, sensory or mental capabilities, or lack of experience and knowledge, unless they have been given supervision or instruction concerning use of the appliance by a person responsible for their safety.

Children should be supervised to ensure that they do not play with the unit.

NOTE: Condenser air is drawn in from the sides or back and discharged out the top. Failure to maintain clearance space will reduce the capacity of the unit and cause premature compressor failure.

INSTALLING LEG

NOTE: Before installing legs, the plastic plugs must be removed.

Unpack the four (4) legs and install them into the threaded holes provided in the bottom of the unit. The installer must provide flexibility in the product and utility supply lines to permit shifting the position of the dispenser sufficiently to clean the area beneath it.

COUNTER MOUNTING

The Viper unit must be sealed to the counter. The MOUNTING TEMPLATE (Figure 3.) indicates where openings can be cut in the counter. Locate the desired position for the dispenser, then mark the outline dimensions on the counter using the MOUNTING TEMPLATE. Cut openings in the counter.

Apply a continuous bead of National Sanitation Foundation (NSF) listed silastic sealant (Dow 732 or equal) approximately 1/4" inside of the unit outline dimensions and around all openings. Then, position the unit on the counter within the outline dimensions. All excess sealant must be wiped away immediately.

The beverage tubes, drain tube and power cord are routed through the large opening in the bottom of the unit. See the MOUNTING TEMPLATE (see Figure 3.), for locating the required clearance hole in the counter for these utility lines.

COUNTERTOP TEMPLATE INSTALLATION INSTRUCTIONS

Use the template shown in Figure 3. and the dimensions shown in Table 1. to drill the necessary holes for installing the unit.

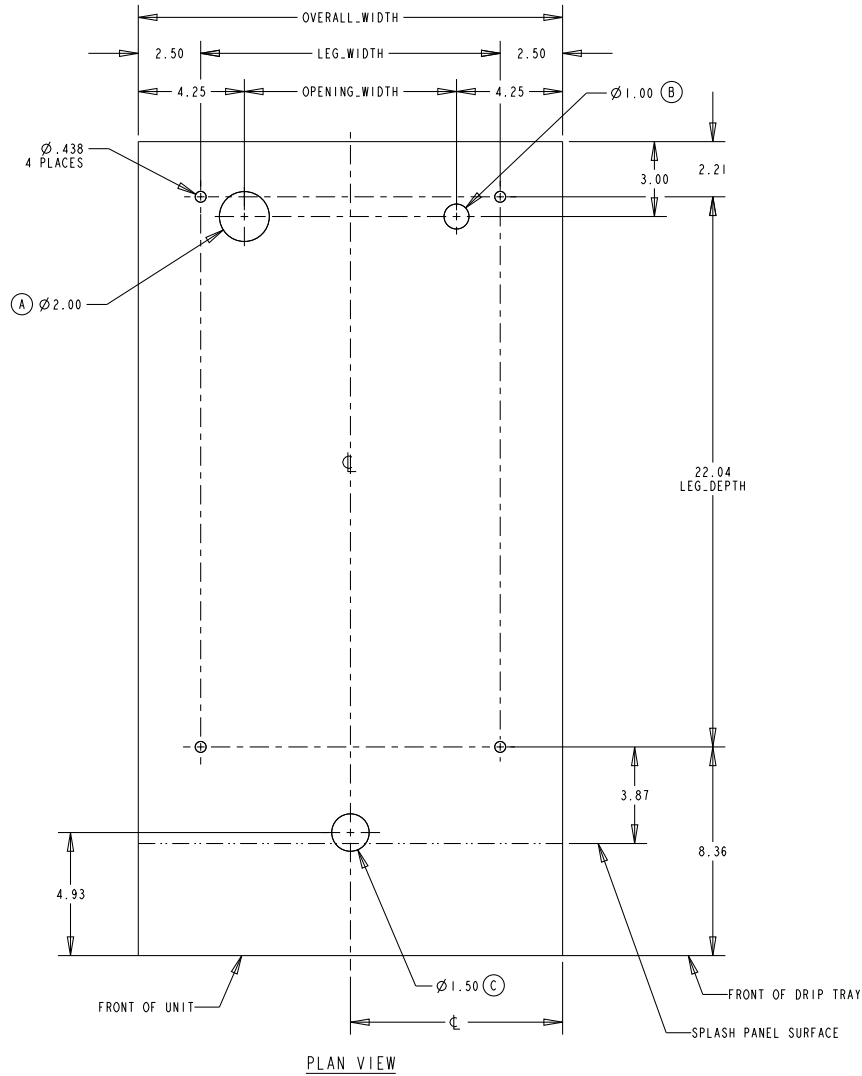

Figure 3.

- A - Opening for Product Tubes
- B - Opening for Electrical Cables
- C - Opening for Drip Tray Drain

Table 1.

Model	Overall Width (In.)	Leg Width (In.)	Opening Width (In.)	Center Line (In.)
2FL	17.00	12.00	10.25	8.50
3FL	22.90	17.90	14.40	11.45
4FL	29.00	24.00	22.25	14.50

BACKROOM REQUIREMENTS

Typically the supplies for the unit are located in a backroom adjoining the service area. Syrup, water and CO₂ lines are then run from the backroom to the service area. The backroom supplies (syrup boxes, CO₂, water filters and pumps) are typically installed on a rack system that sits on the floor, as shown in Figure 4. The CO₂ cylinder is normally mounted against the wall.



Figure 4.

SUPPLY CONNECTIONS

All of the electrical and supply connections to the unit are typically located near the bottom rear of the unit. There are alternate locations for the electrical and supply connections on the bottom of the unit, below the rear locations. The bottom connection locations may be used if the unit is located directly against a wall.

The electrical connection is located at the left side of the rear panel and the tubing supplies are located on the right side, as shown in Figure 5.

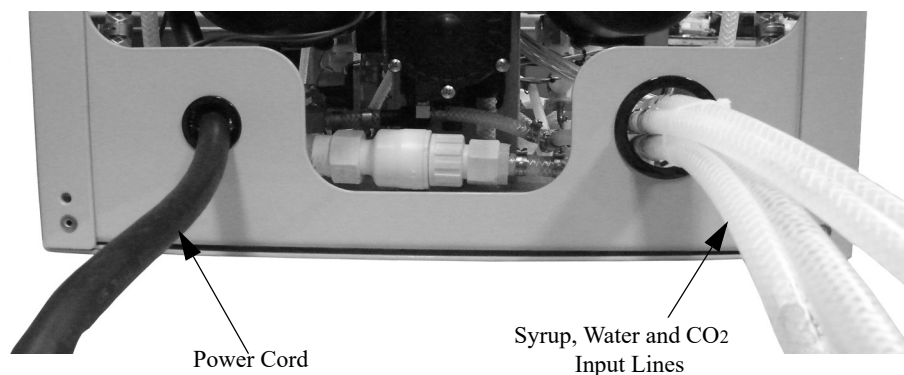

Figure 5.

Electrical Requirements

Refer to the nameplate to determine the power requirements before connecting electrical power to the unit. All of the power cords shall comply with safety requirements outlined in the EC Standards (EN60335-1 1 Clause 24.1) in countries where CE compliance is required. All cords must be HD 21 or HD 22.

Line Voltage

The recommended line voltage range for the Viper unit is 215 to 245VAC. Measure the voltage at the wall outlet to verify proper wiring of the outlet before plugging the Viper unit in.

Power

The power circuit must have some sort of overload protection, such as a circuit breaker or fuse that meets local and national electrical codes. Table 2. shows the power requirements for the various types of units.

Table 2.

2-Barrel 60Hz	3-Barrel 60Hz	4-Barrel 60Hz	2-Barrel 50Hz	3-Barrel 50Hz
20 A. Circuit	30 A. Circuit	30 A. Circuit	20 A. Circuit	30 A. Circuit

Electrical Connections

50Hz and 60Hz units are supplied with the power cord attached. Skip installation information in Table 3. and begin with the Water Supply Requirements section.

(For reference only, to service the power cord for AC power input, perform the procedure as mentioned in Table 3.)

Table 3.

Step	Action
1	Ensure that power to the unit is off. DO NOT plug the power cord into the wall outlet at this time.
2	50 Hz unit remove the right side and rear panel from the unit. 60 Hz unit open the merchandiser door to access main electrical box.
3	Remove the cover from the electrical box.
4	Feed the power cord through the strain relief, as shown in Figure 6. for 60 Hz and see Figure 7. for 50Hz.
5	Pull the slack out of cable and tighten the strain relief (see Figure 6. for 60 Hz and see Figure 7. for 50 Hz)
6	Connect the colored wire to the appropriate terminal on the terminal block.
7	Connect the black wire to the appropriate terminal on the terminal block.
8	Connect the green wire to the ground terminal next to the terminal block.
9	Replace the power box cover. DO NOT TURN ON THE POWER at this time.

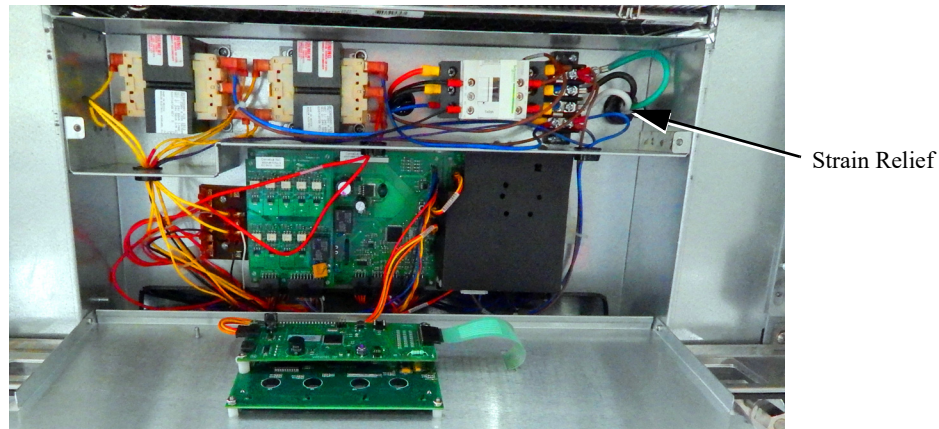

Figure 6. (60 Hz unit)

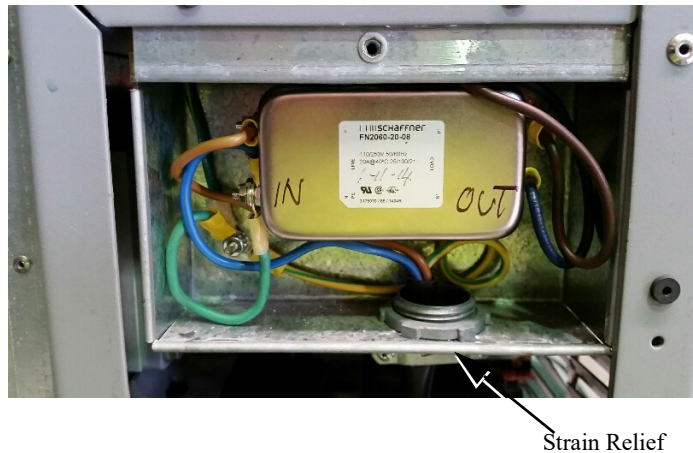

Figure 7. (50Hz unit)

Water Supply Requirements

NOTE: Water connections require 1/2" I.D. tubing. All hoses must reach the back of the unit plus an adequate amount of extra tubing to allow the unit to be pulled out for servicing.

The Viper unit is designed as a high throughput unit. It is very important that the incoming water line is dedicated to the unit. This line should not have any other machines connected which could cause a water surge, such as coffee makers or ice machines.

IMPORTANT:

The water supply should be consistent with proper water quality standards (neutral pH of 7.0 to 8.0), and should not be connected to a water softener. Drink quality may be affected by poor water conditions. Water connections should be sized, installed and maintained according to federal, state and local laws.

NOTE: Size, install, and maintain the water pipe, connections, and fixtures directly connected to a potable water supply in accordance with Federal, State, and Local codes. It is the installer's responsibility to ensure that the potable water supply is equipped with protection against backflow. This protection can be an air gap as defined by ANSI/ASME A112.1.2-1979 or by an approved vacuum breaker or other approved method. If the flowing water pressure at the back of the unit is less than the specified 25 psi and 100 GPH flowrate (per 2 barrels) a water pressure booster is required. It is recommended that a water shutoff valve and water filter be installed in the water supply line.

Water Connections

Use the appropriate fittings and clamps to connect the water line to the unit. Run the tubing for the water (1/2 in. ID, Min.) from the water source in the backroom to the unit and make all appropriate connections. Do not turn on the water supply to the unit.

CO₂ Requirements



WARNING:

CO₂ displaces oxygen. Persons exposed to high concentrations of CO₂ will experience tremors, followed by loss of consciousness and death. It is very important to prevent CO₂ leaks, especially in small unventilated areas. If a CO₂ leak occurs ventilate the area before fixing the leak.

NOTE: There are two CO₂ delivery systems available: High Pressure Cylinder; Low Pressure Bulk System.

High pressure Cylinder requires a primary regulator with a minimum inlet pressure of 500 psi.

Low Pressure Bulk System requires a secondary regulator with a maximum inlet pressure of 200 psi.

NOTE: CO₂ connections require 3/8" I.D. tubing. All hoses must reach the back of the unit plus an adequate amount of extra tubing to allow the unit to be pulled out for servicing.

NOTE: Use a dedicated secondary regulator adjusted to 75 ±1 psig to supply the unit.

CO₂ Connections

Use a source-dedicated secondary regulator, fittings and clamps to connect the CO₂ line to the unit, as shown in Figure 8. Set the regulator for 75 ±1 psig at the unit. Run the tubing for the CO₂ from the secondary regulator to the unit and make all appropriate connections. Ideally, locate the regulator within 3 ft. of the unit. Another secondary regulator is to be used to supply the Bag in Box pumps. It is to be set to 75 psig, not lower. Do not turn on the CO₂ supply to the unit.

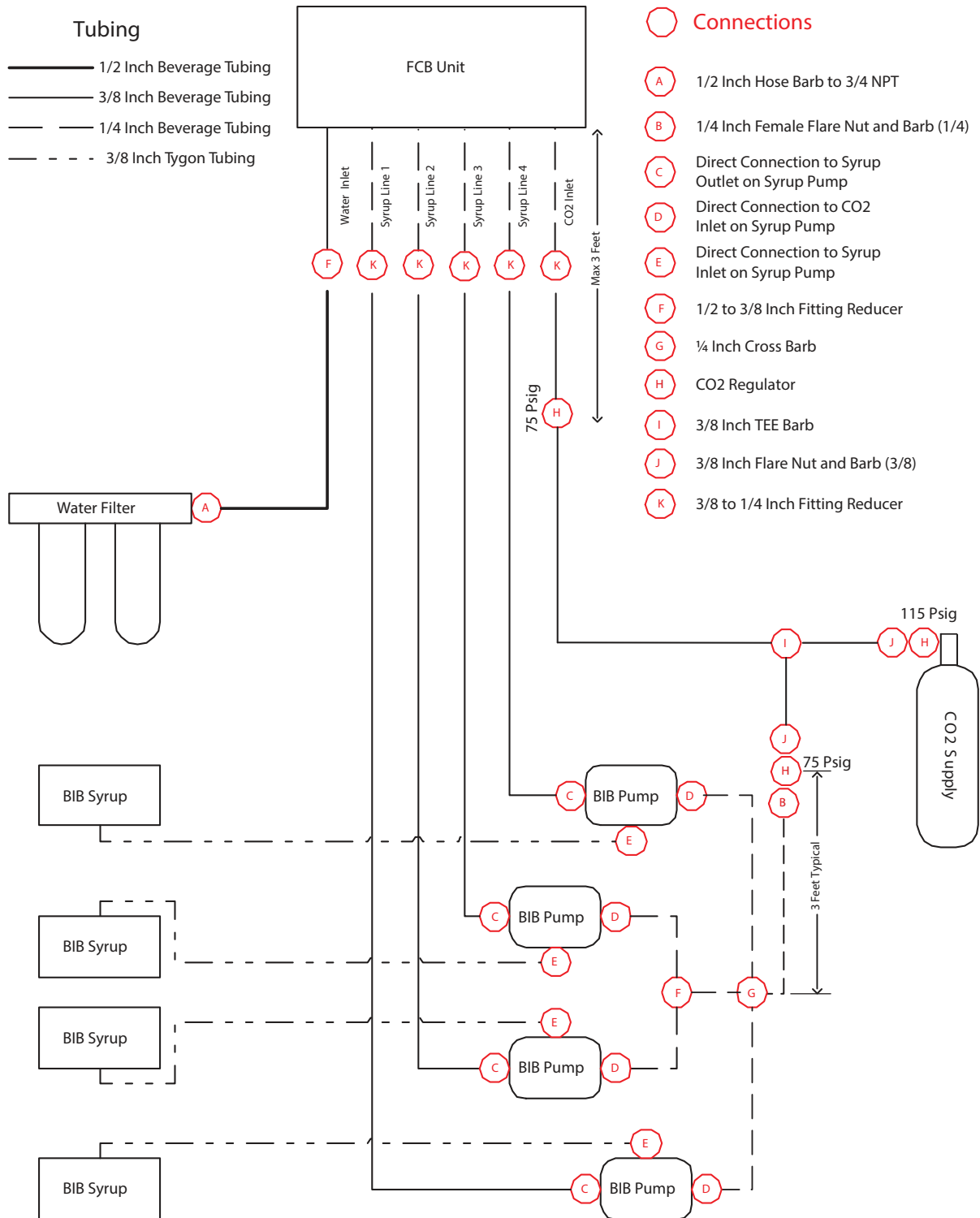

Figure 8. Cylinder CO2 Connection

Syrup Requirements

NOTE: Syrup connections require 3/8" I.D. tubing. All hoses must reach the back of the unit plus an adequate amount of extra tubing to allow the unit to be pulled out for servicing.

Syrup Connections

Use the appropriate fittings and clamps to connect the syrup line to the unit. Run the tubing for the syrup (3/8 in. ID, Min.) from the backroom to the unit and make all appropriate connections. Do not turn on the syrup supply to the unit.

Testing Power

The following procedure provides a minimal operational test of the power to the unit. Perform the procedure in Table 4.

Table 4.

Step	Action
1	Verify the voltage being supplied to the unit. It should be between 215 and 245 Volts, measured at the wall outlet.
2	Plug in the unit power cord and turn on power to the unit.
3	The barrels are off when the unit is initially powered up and the unit displays the "Water Out" message.
4	Unit powers up with Do Not Drink and Out of Product lights on.
5	If the unit displays normal startup operation, proceed to "Setting Up the Control Panel" on page 21.

INSTALLING THE DRIP TRAY

Slide the drip tray into the two brackets protruding from the bottom of the unit until the tray contacts the two detents in the brackets. then place the cup rest on the drip tray. See Figure 9.

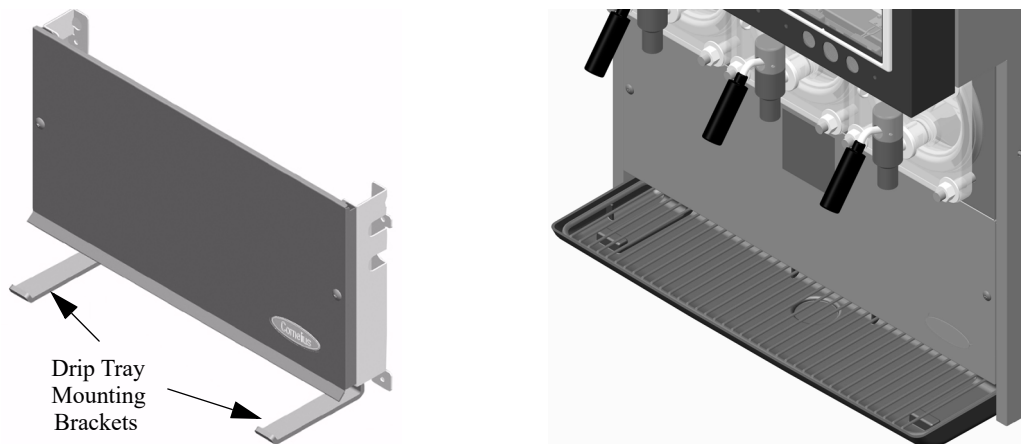

Figure 9.

INSTALLING THE GRAPHICS SHEET

See Figure 10. for installing the merchandiser graphics.

Remove the screw from the top of the merchandiser door, flip the top cover backward and insert the graphic sheet. The graphic sheet should be inserted between the diffuser and the clear plastic graphic lens. Once the graphics are in place, flip the top cover back to the original position, replace and tighten the screw.



Figure 10.

INSTALLING THE FLAVOR CARD

See Figure 11. for installing the flavor card.

Insert the flavor card in to the flavor card window as shown.



Figure 11.

CART INFORMATION AND MOUNTING

The Viper unit may be mounted on a mobile cart (Cornelius part no. 620043075 for 2-barrel unit, 620053990 for 3-barrel unit and 620046556 for 4-barrel unit) which allows some movement of the unit for service and cleaning. There are four captive nuts on the bottom of the Viper to accommodate four 3/8-16 bolts. These bolts must be installed to secure the unit to the cart.

These carts are also designed with movable wheels that act as outriggers to provide stability to the unit when it is being moved.

⚠ WARNING:

The above listed mounting bolts must be installed and the wheels extended and locked in the outboard position prior to moving the unit.

Failure to comply could result in serious injury, death or equipment damage.

This completes the initial installation of the unit. The following sections describe the control panel operation and commissioning the unit.

Servicing Motorman Dispensing Valves

NOTE: Dispensing valves with caged o-rings should be serviced (lubricated) every 6 months or more frequently if the valve lever gets tight to operate. Caged O-rings should be replaced every 12 months.

Refer to and perform the procedure in Table 5 to lubricate or change the caged o-rings in each dispensing valve on the unit.

Suggested Sanitizers

KAY-5® Sanitizer/Cleaner (100 PPM)

Mix one packet of KAY-5® Sanitizer/Cleaner per 2.5 gallons of tap water [70°-100°F (24°-35°C)] according to manufacturer's instructions to ensure 100 PPM of available chlorine.

Household Bleach (200 PPM)

For 6% Sodium Hypochlorite bleach, mix 2.5 fl oz (75mL) in 5 gallons of tap water [70°-100°F (24°-35°C)]. For 5.25% Sodium Hypochlorite bleach, mix 2.2 fl oz (66mL) of bleach in 5 gallons of tap water [75°-95°F (24°-35°C)]. This will ensure a bleach solution of 200 PPM of available chlorine.

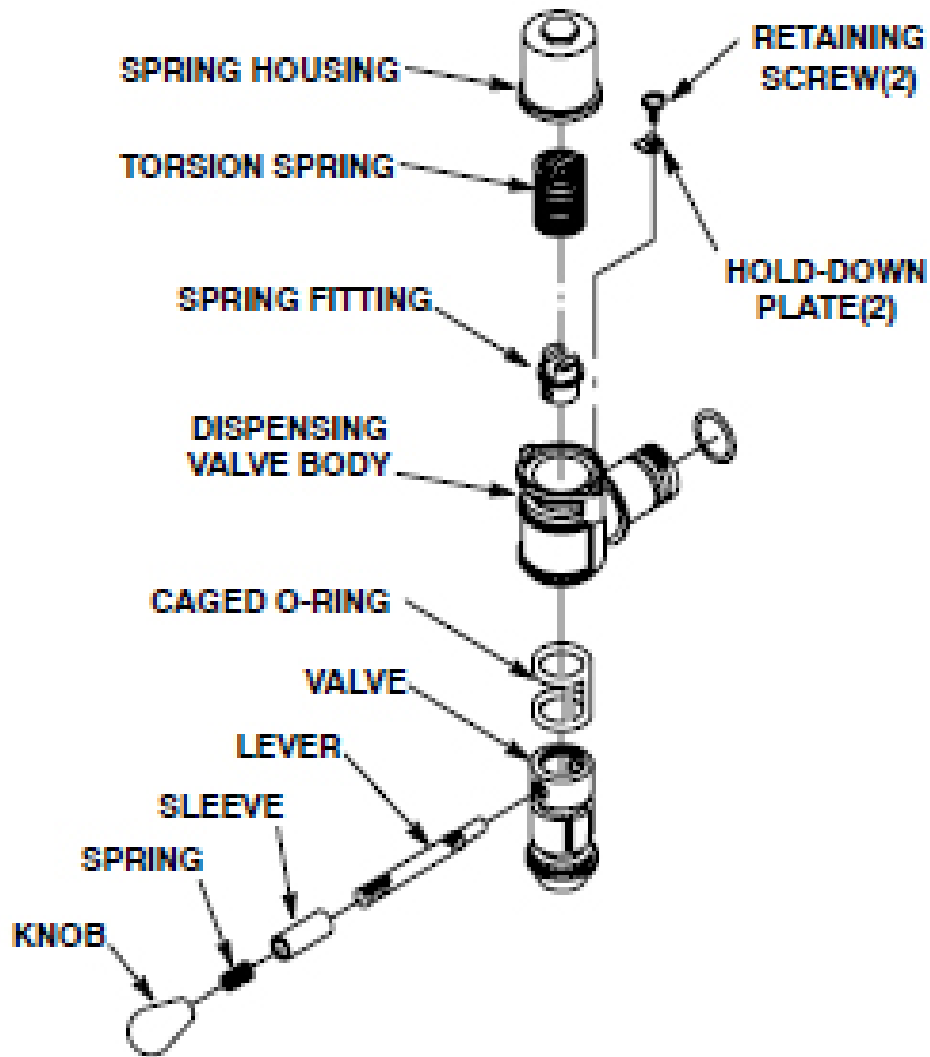

Figure 12. Self-Closing Dispensing Valve

 **WARNING:**

In Step 1, when purging is complete, disconnect electrical power from the unit. Failure to disconnect the power could result in serious injury, death, or equipment damage.

Table 5.

Step	Action
1.	Defrost freeze cylinders, shut unit down, disconnect electrical power from Unit.
2.	Perform the procedure in Table 7 to empty the barrels.
3.	Remove the hex nuts and flat washers securing the faceplate to the freeze barrel, then remove the faceplate from the barrel.
4.	Carefully remove the large o-ring from the faceplate.
5.	Unscrew the relief valve from the faceplate.
6.	Disassemble the dispensing valve (Figure 12.).
7.	Remove ice ball grate from faceplate, if applicable
8.	Remove the two screws and hold-down plates securing the spring housing to the dispensing valve body, then remove the housing.
9.	Remove the torsion spring from the dispensing valve.
10.	Remove the knob, spring, sleeve, and lever from the dispensing valve.
11.	Remove spring fitting from dispensing valve.
12.	Press the valve with the caged O-ring, down and out of the dispensing valve body.
13.	Carefully remove the caged O-ring from the valve.
14.	Wash all the parts in warm water. Remove all traces of syrup and lubricant, especially from the faceplate, o-rings, ice ball grate (if applicable), and dispensing valve. If parts are excessively coated, wipe clean with a paper towel to remove excess syrup and lubricant, especially from caged o-ring and dispensing valve. Use a brush (provided with the unit) to clean the faceplate relief valve passages.
15.	Submerge all the parts in a sanitizing solution according to the suggested sanitizers above for 10 minutes (no more than 15 min).
16.	Remove the parts from the sanitizing solution and place them on clean paper towels.
17.	Assemble the dispensing valve. Rinse them with warm water, and place them on clean paper towels.
18.	Lubricate the caged o-ring. Carefully install the caged o-ring onto the valve from the straight end (opposite tapered end). Lubricate the grooves that the o-ring rides to fill in all void areas around the o-ring.
19.	Carefully install the valve with the caged o-ring in the dispensing valve body.
20.	Install the spring fitting, knob and lever parts, torsion spring and spring housing assembly by reversing the removal procedure. Do not tighten down the hold-down plates securing the spring housing at this time.
21.	After re-installing the faceplate, turn the dispensing valve spring housing to the left (counterclockwise) to put tension on the tension spring. Apply just enough tension so that the dispense valve shaft returns to the closed position after release. Do not over-tighten. Overtightening results in a high activation force on the valve.

NOTE: Use Dow-Corning DC-111 (P/N 321471000) light grade silicone lubricant to lubricate the O-rings.

Servicing SPH Dispensing Valves

Sanitizing the System

The syrup systems should be sanitized every 180 days by a qualified service technician following the sanitizer manufacturer's recommendations or when changing syrup types.

The sanitizing process consists of emptying the barrel Table 7, washing the lines and barrel, cleaning the BIB connectors, rinsing and refilling the system.

NOTE: Sanitizing should only be performed by qualified service technicians.

Suggested Sanitizers

KAY-5® Sanitizer/Cleaner (100 PPM)

Mix one packet of KAY-5® Sanitizer/Cleaner per 2.5 gallons of tap water [70°-100°F (24°-35°C)] according to manufacturer's instructions to ensure 100 PPM of available chlorine.

Household Bleach (200 PPM)

For 6% Sodium Hypochlorite bleach, mix 2.5 fl oz (75mL) in 5 gallons of tap water [70°-100°F (24°-35°C)]. For 5.25% Sodium Hypochlorite bleach, mix 2.2 fl oz (66mL) of bleach in 5 gallons of tap water [75°-95°F (24°-35°C)]. This will ensure a bleach solution of 200 PPM of available chlorine.

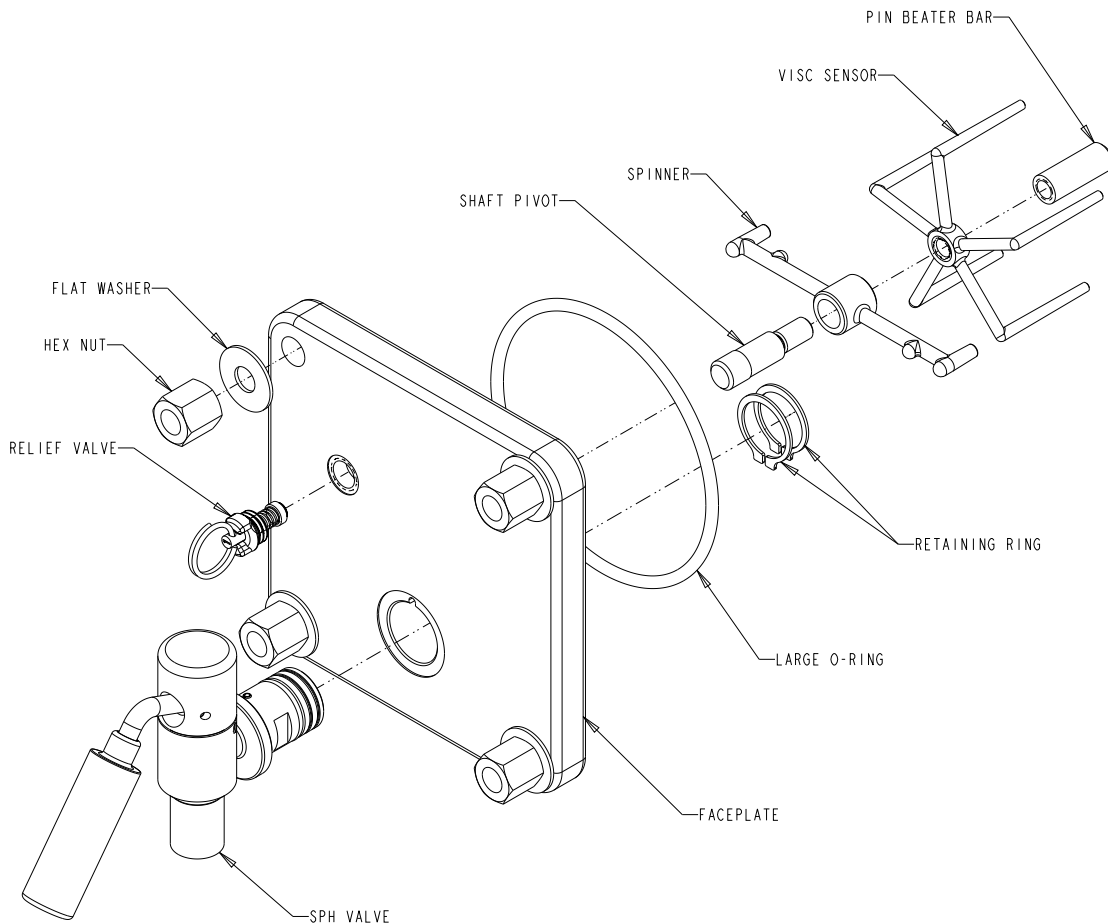

Figure 13.

⚠ WARNING:

In **Step 1**, when defrost is complete, disconnect electrical power from the unit. Failure to disconnect the power could result in serious injury, death, or equipment damage.

Table 6.

Step	Action
1.	Defrost freeze cylinders, shut unit down, disconnect electrical power from Unit.
2.	Perform the procedure in Table 7 to empty the barrels.
3.	Remove the hex nuts and flat washers securing the faceplate to the freeze barrel, then remove the faceplate from the barrel.
4.	Carefully remove the large o-ring from the faceplate
5.	Unscrew the relief valve from the faceplate.
6.	Disassemble the dispensing valve (see Figure 13).
7.	Remove Ice Ball Grate from faceplate, if applicable.
8.	Wash all the parts in warm water. Remove all traces of syrup and lubricant, especially from the faceplate, o-rings, ice ball grate (if applicable), and dispensing valve. If parts are excessively coated, wipe clean with a paper towel to remove excess syrup and lubricant, especially from caged o-ring and dispensing valve. Use a brush (provided with the unit) to clean the faceplate relief valve passages.
9.	Submerge all the parts in a sanitizing solution according to the suggested sanitizers above for 10 minutes (no more than 15 min).
10.	Remove the parts from the sanitizing solution, rinse them with warm water, and place them on clean paper towels.
11.	Carefully re-install the valve and corresponding parts into the faceplate, and re-install the faceplate onto the machine.

NOTE: Use Dow-Corning DC-111 (P/N 321471000) light grade silicone lubricant to lubricate the faceplate O-ring.

Emptying a Barrel

To empty the barrel, perform the procedure in Table 7

Table 7.

Step	Action
1.	From the Barrel Status menu, press the DFRST button.
2.	When the barrel is defrosted, go to the Maintenance menu. If the security feature is active, access the Maintenance menu by pressing and holding the far left and right buttons simultaneously for approximately five seconds.
3.	Remove the splash panel. See "BRIX Setup Menu".
4.	Turn the Product/BRIX valve 90 degrees clockwise to shutoff product to the barrel.
5.	Place a large waste container under the dispense valve and drain as much product as possible from the barrel.
6.	When the pressure in the barrel drops, from the Barrel Maintenance menu, press the PURGE button to repressurize the barrel with CO2. As product level lowers in the barrel, partially close the valve to avoid spurting.
7.	Disconnect the BIB from the unit.

NOTE: The unit should be sanitized every 180 days by a qualified service technician following the sanitizer manufacturer's recommendations.

Flushing the System of Syrup

After emptying the barrel, the barrel should be flushed of product before proceeding with the sanitizing procedure. Perform the procedure in Table 8.

Table 8.

Step	Action
1.	Fill a clean 5-gallon pail with plain water.
2.	Connect a sanitizing fitting (p/n cc 28688) to the BIB connector. Put the connector in the bucket of water.
3.	Make sure the Product/BRIX valve is in the BRIX position.
4.	Hold a waste container under the brix tube to collect syrup from the syrup line and open the manual syrup flow valve. to start filling the syrup line with plain water. Continue to hold the manual syrup flow valve open until clean water starts coming out of the BRIX tube.
5.	Release the manual syrup flow valve and turn the Product/BRIX valve to the Product position.
6.	Open the manual water flow valve to start filling the barrel with water. At the same time, open the faceplate relief valve until water comes out.
7.	When the barrel is full, press the SPIN button on the Barrel Status menu, while highlighting the appropriate barrel. This starts the scraper blade. Allow blade to operate for fifteen seconds.
8.	Turn barrel OFF by pressing the OFF button.
9.	Place a waste container under the barrel dispensing valve. Open the dispensing valve and dispense all wash water from the barrel. When the pressure in the barrel drops, from the Barrel Maintenance menu, press the PURGE button to re-pressurize the barrel with CO ₂ . As the wash water level lowers in the barrel, partially close the valve to avoid spurting.
10.	Perform rear barrel seal replacement. See "Barrel Motor Seal Replacement".
11.	Perform inspection and replacement of scraper blades. See "Inspecting and Replacing Scraper Blades".
12.	Perform a leak test on the barrel. See "Motor Seal Leak Test".

Sanitizing the Barrel

Sanitize the syrup system and barrel by performing the procedure shown in Table 9.

Table 9.

Step	Action
1.	Use a clean 5-gallon pall filled with a sanitizing solution and water at a temperature of 90° F to 110° F (32° C to 43° C). Prepare the sanitizing solution according to the instructions in the "Suggested Sanitizers" section above.
2.	Connect a sanitizing fitting (p/n cc 28688) to the BIB connector. Put the connector in the bucket of sanitizing solution.
3.	Make sure the Product/BRIX valve is in the BRIX position.
4.	Hold waste container under the BRIX tube to collect flush water from the syrup line and open the manual syrup flow valve to start filling the syrup line with sanitizing solution. Continue to hold the syrup flow valve open until sanitizing solution starts coming out of the BRIX tube.
5.	Turn the Product/BRIX valve in the Product position.
6.	Manually override (open) the syrup flow valve to fill the barrel with sanitizing solution.
7.	Fill the barrel with sanitizing solution by opening the faceplate relief valve until sanitizing solution comes out of the relief port.
8.	Hold a 16 oz. cup under the dispense valve. Hold the dispense valve fully open until the cup is full.
9.	Use the brush provided with the unit to clean the relief port and clean the outlet of the dispense valve with sanitizing solution.
10.	From the Barrel Status menu, press the SPIN button while highlighting the appropriate barrel. This starts the scraper blade. Allow blade to operate for minimum of 10, but no more than 15 minutes. Turn the scrapper blade off by pressing the OFF button.
11.	Place a large container under the dispense valve and drain as much sanitizing solution as possible from the barrel.
12.	When the pressure in the barrel drops, from the Barrel Maintenance menu, press the PURGE button to re-pressurize the barrel with CO ₂ . As sanitizing solution level lowers in the barrel, partially close the valve to avoid spurting.

Flushing the System

Flush the wash water from the system by performing the procedure in Table 10.



CAUTION:

Flush the system thoroughly, residual sanitizing solution left in the system may create a health hazard.

Table 10.

Step	Action
1.	Turn the Product/BRIX valve to the Product position.
2.	Manually open the manual water flow valve to start filling the barrel with wash water. At the same time, open the face-plate relief valve until water comes out.
3.	From the Barrel Status menu, press the SPIN button while highlighting the appropriate barrel. This starts the scraper blade. Allow the blade to operate for fifteen seconds, then turn barrel OFF by pressing the OFF button.
4.	To drain the water from the system, turn the barrel OFF.
5.	Place a container under the barrel dispensing valve. Open the dispensing valve and dispense all rinse water from the barrel. When the pressure in the barrel drops, from the Barrel Maintenance menu, press the PURGE button to re-pressurize the barrel with CO ₂ . As the wash water level lowers in the barrel, partially close the valve to avoid spurting.
6.	Remove the sanitizing fitting (p/n cc 28688) from the BIB connector and connect a BIB containing syrup to the syrup line.
7.	Rotate the Product/BRIX valve to the BRIX position and open the valve at the end of the tube.
8.	Hold a waste container under the BRIX tube to collect the sanitizing solution from the syrup line and open the manual syrup flow valve to start filling the syrup line with syrup. Continue to hold open the syrup flow valve until syrup starts coming out of the BRIX tube.
9.	Perform a BRIX setup. See "BRIX Setup Menu".
10.	Fill the barrel with product as described.
11.	Perform motor calibration. See "Calibrating a Motor"

CONTROL PANEL OVERVIEW

Behind the merchandiser is the control panel which includes the LCD display, shown in Figure 14. This panel controls all the functions of the unit including defrost cycles, viscosity control, sensing of supply pressures and the incoming line voltage as well as other functions and features.

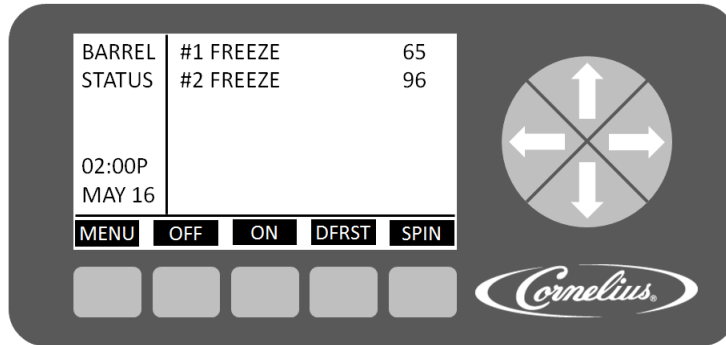

Figure 14.

SETTING UP THE CONTROL PANEL

When the unit is initially powered up, the Main Check menu, shown in Figure 15, is displayed.



Figure 15.

The software runs tests on the flash memory and the EEPROM. If they pass, PASS is displayed to the right of the appropriate line and the system displays the System Check State screen, shown in Figure 16.

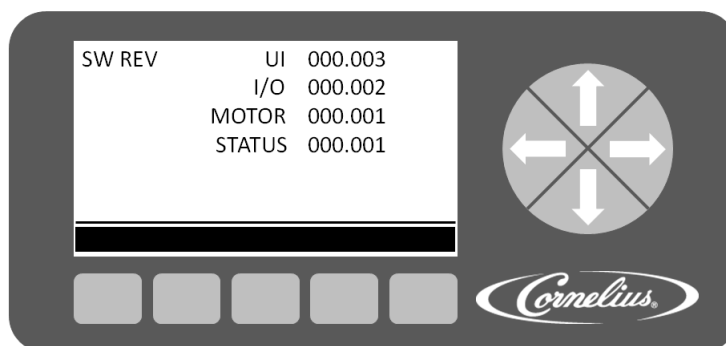

Figure 16.

Once the System Check State verification is complete, the display automatically displays the Barrel Status menu. This is the normal or home screen for the system when the unit is running properly. It shows the status of all barrels in the system, as shown in Figure 17. During initial power up, the barrel status is off, indicating that the unit is in idle mode, with refrigeration off, product delivery off and the barrel motor off.

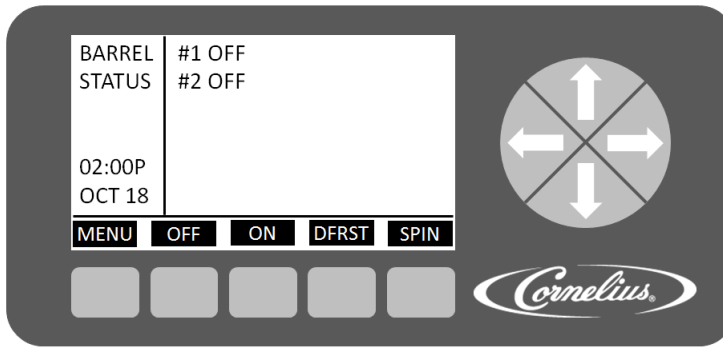

Figure 17.

From this screen, all the other screens may be accessed. The following procedures are required for initial setup of the unit.

- Set the Options
- Set the Clock
- Set the Sleep and Wake Times
- Set the Viscosity

Setting the System Options

The first items that should be set are the formatting options. These formatting options are located in the Option Setup menu. To access the Option Setup menu, press the MENU button on the Barrel Status menu. This displays the MAIN menu, shown in Figure 18. Then press the SETUP button to display the Option Setup menu, shown in Figure 19.

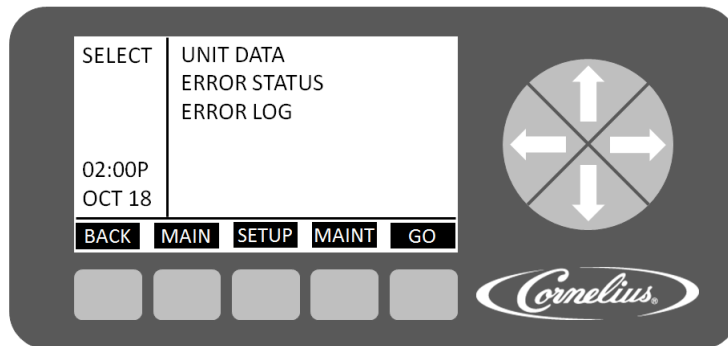

Figure 18.

Use the up and down arrows on the right side of the control panel to move between the various choices on the display. When the OPTION SETUP selection is highlighted, press the GO button to access the menu. The Option Setup menu (Figure 19.) is displayed.

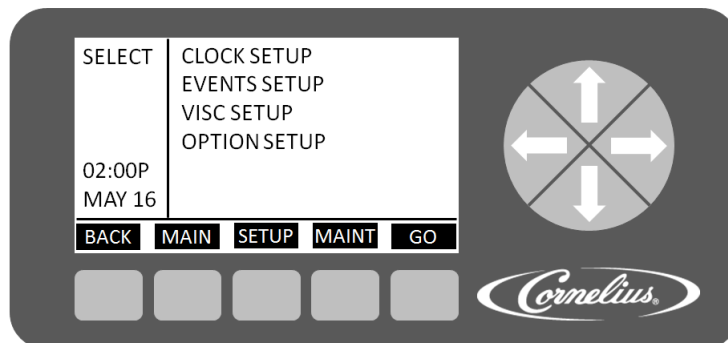

Figure 19.

Setting the Clock

Highlight the CLOCK SETUP field from the Select menu, shown in Figure 19. This displays the Clock Setup menu, shown in Figure 20. To set the time, perform the procedure in Table 11.

Table 11.

Step	Action	Procedure
1	Set clock time	Use the up and down arrows on the right side of the control panel to highlight the TIME display on the screen.
2	Select hour field	Use the left and right arrows to select the hour field
3	Set correct hour	Use the + or - buttons at the bottom of the display to set the proper hour.
4	Select minute field	Use the left and right arrows to select the minute field.
5	Set correct minute	Use the + or - buttons at the bottom of the display to set the proper minute.
6	Select AM/PM field	If the 12 hour clock option is selected, use the left and right arrows to select the AM/PM field.
7	Set AM/PM	Use the + button at the bottom of the display to set the AM/PM setting, if using 12 hour format.

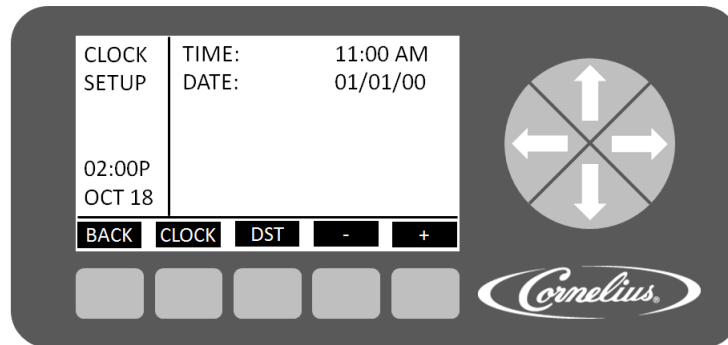

Figure 20.

To set the date, perform the procedure in Table 12. and refer to Figure 20.

Table 12.

Step	Action	Procedure
1	Set date	Use the up and down arrows on the right side of the control panel to highlight the DATE display on the screen.
2	Select month field	Use the left and right arrows to select the month field.
3	Set correct month	Use the + or - buttons at the bottom of the display to set the correct month.
4	Select day field	Use the left and right arrows to select the day field.
5	Set correct day	Use the + or - buttons at the bottom of the display to set the correct day.
6	Select year field	Use the left and right arrows to select the year field.
7	Set correct year	Use the + or - buttons at the bottom of the display to set the correct year.

Setting Daylight Savings Time

Once the date and time are set properly, the daylight savings time settings can be done. Display the Daylight Savings Time menu (Figure 21.) by pressing the DST button at the bottom of the display. To set daylight savings time, perform the procedure in Table 13.

Table 13.

Step	Action	Procedure
1	Set daylight savings time	Press the DST button at the bottom of the display to open the daylight savings time display, shown in Figure 21.
2	Select DST	Use the up and down arrows to select DST.
3	Set DST on	Use the + button to turn on daylight savings time.
4	Select SPRING MONTH	Use the up and down arrows to select SPRING MONTH.
5	Set SPRING MONTH	Use the + or - buttons at the bottom of the display to set the correct month.
6	Select SPRING WEEK	Use the up and down arrows to select SPRING WEEK.
7	Set SPRING WEEK	Use the + or - buttons at the bottom of the display to set the correct week. The choices are 1, 2, 3 or L.
8	Select FALL MONTH	Use the up and down arrows to select FALL MONTH.
9	Set FALL MONTH	Use the + or - buttons at the bottom of the display to set the correct month.
10	Select FALL WEEK	Use the up and down arrows to select FALL WEEK.
11	Set FALL WEEK	Use the + or - buttons at the bottom of the display to set the correct week. The choices are 1, 2, 3 or L.

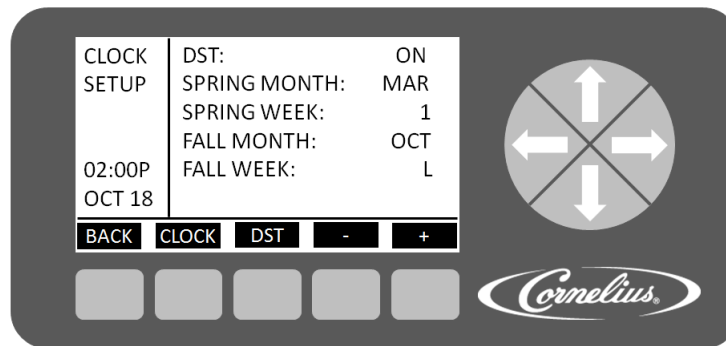

Figure 21.

When the daylight savings settings are complete, press the BACK button to save the settings and return to the Select menu, shown in Figure 19.

Options Setup Menu

The Option Setup menu allows the user to set the various options available in the system. These options are listed in Table 14. The functions of the display buttons change, depending on the highlighted selection on the Option Setup screen. The Option Setup menu is shown in Figure 22.

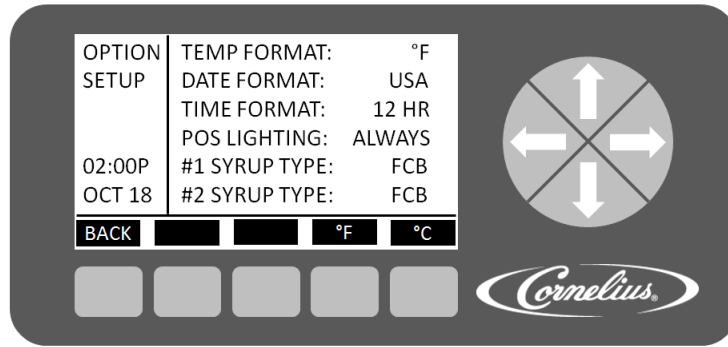

Figure 22.

Table 14.

Option	Button 2	Button 3	Button 4	Button 5
Temp Format			°F	°C
Date Format			USA	EURO
Time Format			12 HR	24 HR
POS Lighting		OFF	ALWAYS	SLEEP
#1 SYRUP TYPE	FCB	FCB-L	FUB	FUB-L
#X SYRUP TYPE	FCB	FCB-L	FUB	FUB-L

When all the options are set to the desired settings for the unit, press the BACK button to store these settings and return to the Select menu, shown in Figure 19.

Setting the Temperature Format

The temperature format displayed by the unit may be set to either Centigrade or Fahrenheit. Press the °F button to display readings in Fahrenheit and press the °C button to display readings in Centigrade.

Setting the Date Format

The date format can be displayed in either United States or European format. To display U.S. date format, press the USA button. This displays the date in mm/dd/yy format. Press the EURO button to display the date in dd/mm/yy format.

Setting the Time Format

Time format can be displayed in either 12 or 24 hour format. To display the clock settings in 12 hour format (1:08 P), press the 12 HR button. To display settings in 24 hour format (23:05), press the 24 HR button.

Setting the POS Lighting

POS Lighting is controlled by the POS LIGHTING field on the Option Setup menu (Figure 22.). To turn off the merchandiser lighting, press the OFF button while the POS LIGHTING field is highlighted. To turn on the merchandiser lighting permanently, press the ALWAYS button. To turn the merchandiser lighting on and off with the Sleep settings, press the SLEEP button.

Setting the Type of Syrup

Syrup type for each barrel may be selected by highlighting the desired barrel and pressing the appropriate button, FCB, FCB-L, FUB or FUB-L. FCB is for Frozen Carbonated Beverage, FCB-L is for Frozen Carbonated Beverages - Light (diet), FUB is for Frozen Non carbonated Beverages and FUB-L is for Frozen Non carbonated Beverages - Light (diet). Each of these settings provides the proper viscosity and temperature settings for the type of syrup being used.

Events Setup Menu

Events setup allows the user to set sleep periods for the unit and to lock out the defrost cycle during peak busy times. Sleep periods and defrost lockouts may be programmed for individual days of the week or for every day of the week, depending on location requirements.

Setting Defrost Lockout

From the Barrel Status menu, shown in Figure 17, press the MENU button and then press the SETUP button to display the Setup menu. Use the up and down arrows on the right of the control to highlight the Events Setup menu, then press GO to enter the menu (Figure 23.).

This menu allows the user to set the unit for a sleep period on individual days or all days of the week. It also provides a lockout for the automatic defrost cycle, so that all barrels have product available during peak usage hours. The lockout can also be set day by day or for all days with up to three lockout periods per day. The defrost lockout affects all barrels in the unit. To set the defrost lockouts, perform the procedure in Table 15. Defrost lockouts should be overlapped by 15 minutes for sequential lockout.

Table 15.

Step	Action	Procedure
1	Set defrost lockout	Open the Events Setup menu, shown in Figure 23.
2	Select DAY	Use the up and down arrows to highlight DAY.
3	Set DAY	Use the + and - buttons at the bottom of the display to set the desired day or all days.
4	Select DEFROST LOCK 1	Use the up and down arrows to highlight DEFROST LOCK 1.
5	Set hour field	Use the left and right arrows to select the hour field. Use the + and - buttons at the bottom of the display to set the desired hour.
6	Set minute field	Use the left and right arrows to select the minute field. Use the + and - buttons at the bottom of the display to set the desired minute (in 15 min. increments).
7	Select AM/PM field	If the 12 hour clock option is selected, use the left and right arrows to select the AM/PM field. Use the + button at the bottom of the display to set the AM/PM field.
8	Save the setting	Press the BACK button at the bottom of the display to save the settings.
9	Select DEFROST LOCK 2	Repeat Steps 2 through 11 for the DEFROST LOCK 2 time, if desired.
10	Select DEFROST LOCK 3	Repeat Steps 2 through 11 for the DEFROST LOCK 3 time, if desired.

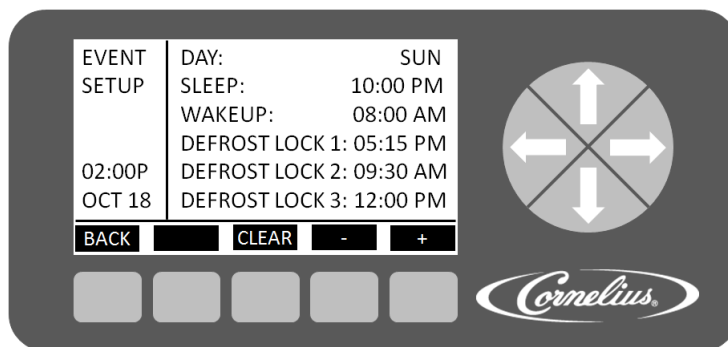

Figure 23.

When the defrost lockout settings are complete, press the BACK button to save the settings and return to the Select menu, shown in Figure 19.

Setting the Sleep and Wake up Times

Sleep and wake up times are set on the Event Setup menu shown in Figure 23. To set the sleep and wake up times, perform the procedure in Table 16.

NOTE: Setting the wake up time ahead of the sleep time on a given day causes the unit to go into the sleep mode for a week unless the operator initiates a manual wake up.

Table 16.

Step	Action	Procedure
1	Set sleep and wake up times	Open the Events Setup menu, shown in Figure 23. by pressing the GO button.
2	Select DAY	Use the up and down arrows to highlight DAY.
3	Set DAY	Use the + or - buttons at the bottom of the display to set the desired day or all days.
4	Select SLEEP	Use the up and down arrows to highlight SLEEP.
5	Set hour field	Use the left and right arrows to select the hour field.
6	Set minute field	Use the left and right arrows to select the minute field.
7	Select AM/PM field	If the 12 hour clock option is selected, use the left and right arrows to select the AM/PM field.
8	Select DAY for Wake up	Repeat Steps 1 through 3.
9	Select WAKEUP	Use the up and down arrows to highlight WAKEUP and repeat Steps 6 through 8 to set the WAKEUP times.
10	Set Wake up day/time	Repeat Steps 5 through 7.
11	Save the WAKEUP setting	Press the BACK button at the bottom of the display to save the wake up setting.

When the sleep and wake up settings are complete, press the BACK button to save the settings and return to the Select menu, shown in Figure 19.

Setting Viscosity

The viscosity maintained in the freeze barrels depends on the type of product being served. Some products are served best at a higher viscosity, while others require a lower viscosity for best quality. The Viscosity menu allows the user to adjust the viscosity in each barrel to the optimum setting for each type of syrup.

Refer to for Table 20. recommended settings based on syrup type.

Table 17.

Step	Action	Procedure
1	Set viscosity range	From the Setup menu (Figure 19.), open the Viscosity Setup menu, shown in Figure 24..
2	Select barrel	Use the up and down arrows to highlight the desired barrel.
3	Set range	Use the + or - buttons at the bottom of the display to set the desired range.
4	Select barrel	Repeat Steps 2 and 3 for each barrel in the machine.

To set all barrels in the system to the same viscosity setting, follow Table 17., and then press the ALL button at the bottom of the display while highlighting the viscosity setting you desire for all the barrels.

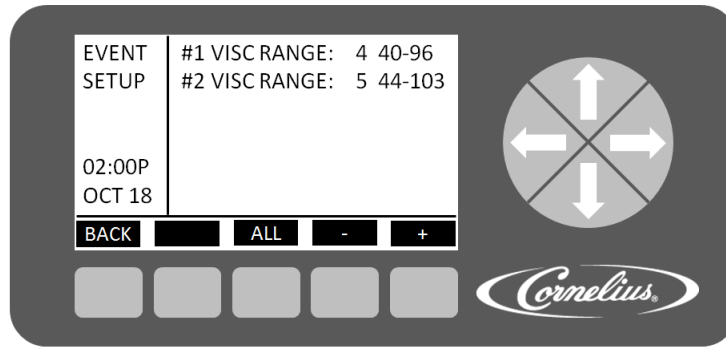

Figure 24.

When the viscosity settings are complete, press the BACK button to save the settings and return to the Select menu, shown in Figure 19.

NOTE: Refer to the service manual for other controller functions and features.

COMMISSIONING THE UNIT

UNIT LOCATION

This appliance is not intended for use by persons (including children) with reduced physical, sensory or mental capabilities, or lack of experience and knowledge, unless they have been given supervision or instruction concerning use of the appliance by a person responsible for their safety.

Children should be supervised to ensure that they do not play with the unit.

Pressurizing the Water System

Perform the procedure in Table 18. to verify the water connection to the unit.

Table 18.

Step	Action
1	Turn on the water supply to the unit.
2	Check the system for leaks.
3	The Do Not Drink and Out of Product lights remain on. NOTE: The H ₂ O Out error does not clear until CO ₂ pressure is applied.
4	Turn the product supply valve to the down (BRIX) position and open the valve at the end of the sample tube.
5	Place the end of the tube in a bucket.
6	Manually lift the water valve at the front of the unit (Figure 25.) to fill the water system.
7	When water flows from the sample tube, the system is full and you may proceed to Table 19. and pressurize the CO ₂ system.
8	Repeat Steps 4 through 7 for each barrel in the unit.

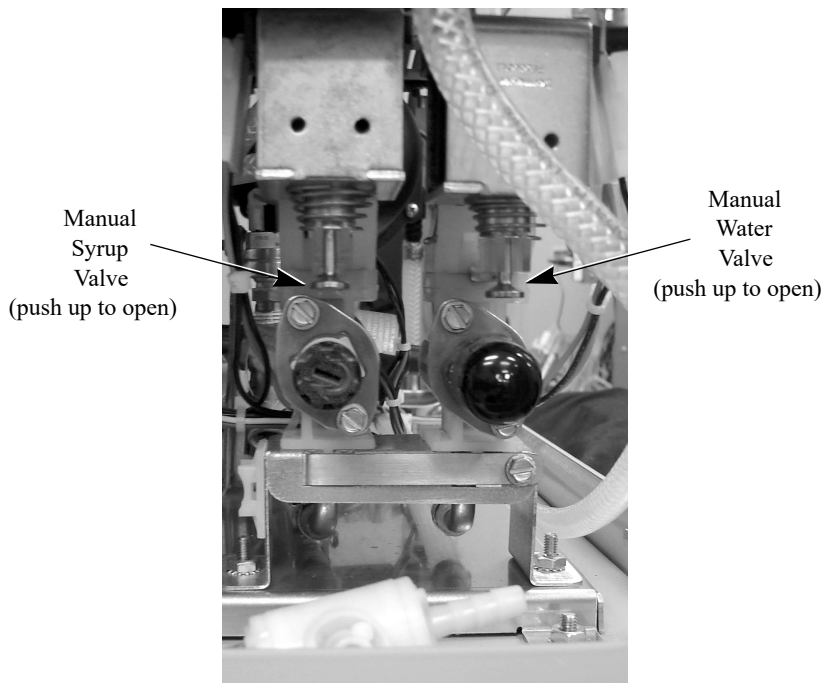

Figure 25.

NOTE: Remove the valve cover to access syrup and water valves.



Pressurizing the CO₂ System

The Viper unit is designed to operate on a CO₂ input pressure of 75 ±1 psig. If the installation location has either an independent tank and regulator or a bulk CO₂ supply that feeds more than one machine, a shutoff valve and secondary regulator must be placed in the line from the bulk supply to the Viper unit to reduce the CO₂ pressure at the unit to 75 ±1 psig. Perform the procedure in Table 19. to pressurize the CO₂ system.

Table 19.

Step	Action
1	Open the CO ₂ cylinder valve slightly to allow lines to slowly fill with gas. When lines are fully pressurized, open the CO ₂ cylinder valve all the way until it back-seats itself (this prevents leaks from the valve).
2	Adjust the CO ₂ cylinder regulator for the unit to 75 +/- 1psig at the unit. DO NOT TURN THE SYRUP CO₂ REGULATOR ON AT THIS TIME.
3	On the right side of the unit, verify that the expansion tank CO ₂ regulator is set to 30 psig, if not correct. NOTE: The expansion tank regulator should not be adjusted when pressure is applied to the barrels.
4	Check and set the CO ₂ barrel regulators (located on the front of the unit behind the splash panel) so that the pressure for each barrel is set to 36 psig for sugar based syrups.
5	The Do Not Drink and Out of Product lights remain on. The “H ₂ O Out” message should clear and the “Syrup Out” message displays.
6	NOTE: Check for CO₂ leaks by turning off the CO₂ supply to the Viper. Wait at least 3 minutes and check the CO₂ cylinder gauge to see if the pressure has dropped.
7	The Do Not Drink and Out of Product lights remain on.

Table 20. provides guidelines for machine settings based on general syrup type. Several factors, including syrup formulation, level of citric acids, etc, will impact settings. These settings are to provide initial adjustments to achieve product overruns in the 80-120% range.

Table 20.

Syrup Type	Syrup Type Set	Viscosity	Pressure	Expansion
FCB Syrup w/ Foaming Agent	FCB	4	36-38 PSIG	30
FCB Syrup w/o Foaming Agent	FCB	4	32-36 PSIG	30
FUB	FUB	3	N/A	30

NOTE: For citric syrups, adjust the CO₂ pressures down by 2-4 PSIG from the above to compensate for the lower CO₂ adsorption.

Pressurizing the Syrup System

Perform the procedure in Table 21. to pressurize the syrup system.

Table 21.

Step	Action
1	Slowly turn on the CO ₂ regulator for the syrup BIB pumps to avoid damaging them and set them so there is 75 psig, no lower syrup pressure at the unit.
2	Turn the product supply valve to the down (BRIX) position and open the valve at the end of the sample tube.
3	Place the end of the tube in a bucket.
4	Manually press the syrup valve at the front of the unit (Figure 25.) to fill the syrup system.
5	When syrup flows from the sample tube, the system is full.
6	Check the system for syrup leaks.
7	Repeat Steps 2 through 5 for each barrel in the unit.
8	Verify that the Do Not Drink and Out of Product lights go off on all barrels and the "Syrup Out" message clears.

Setting BRIX

BRIX is important to the quality of the final product. The BRIX menu provides a measured amount of product with a constant volume so that a BRIX comparison can be made between samples. The unit is set to provide a three second dispense of the product for BRIX testing.

Testing BRIX Level

The BRIX Setup menu is located on the Maintenance menu. The Maintenance menu is shown in Figure 26.

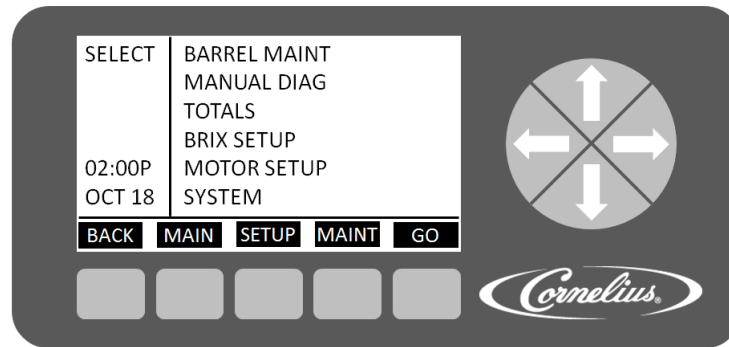

Figure 26.

The BRIX Setup menu facilitates the extraction of a sample of product from the unit for BRIX measurement. There is a three second dispense that produces a constant volume dispense so that BRIX comparison can be made between samples.

Table 22.

Step	Action
1	Remove the drip tray by sliding it forward off the mounting brackets.
2	Remove the splash panel behind the drip tray (if not removed).
3	Turn product supply valve to the Down (BRIX) position for the barrel you are going to test. (See Figure 27.)
4	From the Maintenance menu (Figure 26.), open the BRIX Setup menu. NOTE: Entering the BRIX Setup menu turns off all the barrels in the system.
5	Use the up and down arrows to highlight BRIX SETUP. Press the GO button at the bottom of the display.

Table 22.

Step	Action
6	Again use the up and down arrows to select the barrel you wish to perform BRIX on. NOTE: Pressing CANCEL will stop the process.
7	Locate the appropriate barrel sample tube and hold a cup under it.
8	Open the cap at the end of the sample tube. Press the BRIX button. The product pump will pump product for approximately 3 seconds. After the sample is dispensed Press the BRIX button twice more to dispense product two more times. Discard all three of these samples.
9	Press the BRIX button again. Collect a sample from the cup.
10	Place adequate amount of the sample on a refractometer and read the BRIX value. A target BRIX reading of 13.0 (±1.0) is normally desired for sugar-based syrups. Lower values for some diet syrups can be specified. Check with the syrup manufacturer if you are not sure.
11	If BRIX level needs to be adjusted, perform the Adjusting BRIX Level procedure in Table 23.
12	Manually press the water valve at the front of the unit (Figure 25.) in the middle of the water flow regulator to clean out the sample tube and close the valve at end of the sample tube.
13	Repeat this procedure for each barrel in the system.
14	Replace splash panel on unit.



Valves shown in Product position w/ Splash Panel Removed

Figure 27.

Adjusting BRIX Level

If the BRIX reading is out of its proper range, the syrup level should be adjusted to bring BRIX into the proper range. NEVER change the WATER FLOW CONTROL setting to adjust BRIX. The syrup flow control adjustment valve is shown in Figure 28. Perform the procedure in Table 23.

Table 23.

Step	Action
1	Remove the drip tray and the access panel behind it, if not already removed.
2	To increase the BRIX reading, turn the syrup flow control knob clockwise. Turn it counter-clockwise to decrease the BRIX reading. Never adjust the flow control more than 1/2-turn at a time.
3	Repeat steps 7 through 10 of Table 22. for each adjustment until the proper BRIX setting is achieved.
4	Manually press the water valve at the front of the unit (Figure 25.) in the middle of the water flow regulator to clean out the sample tube and close the valve at end of the sample tube.
5	Once the BRIX is properly set, turn the product supply valve to the upright (Product) position for the barrel you are testing. (See Figure 27.)
6	From the Barrel Maintenance menu, press the PURGE button to fill the barrel with CO ₂ .
7	Bleed the air from the face plate relief valves for 30 seconds each to remove air from the barrels.
8	Go to the Barrel Maintenance menu and press FILL to fill the barrel.
9	Fill the barrel by opening up the barrel faceplate relief valve for the barrel (See Figure 29.). Fill the barrel to the level shown in (approx. half way between the relief valve and the top of the barrel) for 80-120% overrun.
10	After finishing BRIX testing and adjustment for the first barrel, repeat this procedure for each of the other barrels, as required.
11	When BRIX adjustments are complete and all the air is purged from the system, replace the splash panel. NOTE: If any of the valve covers were removed during the process, make sure to replace them.

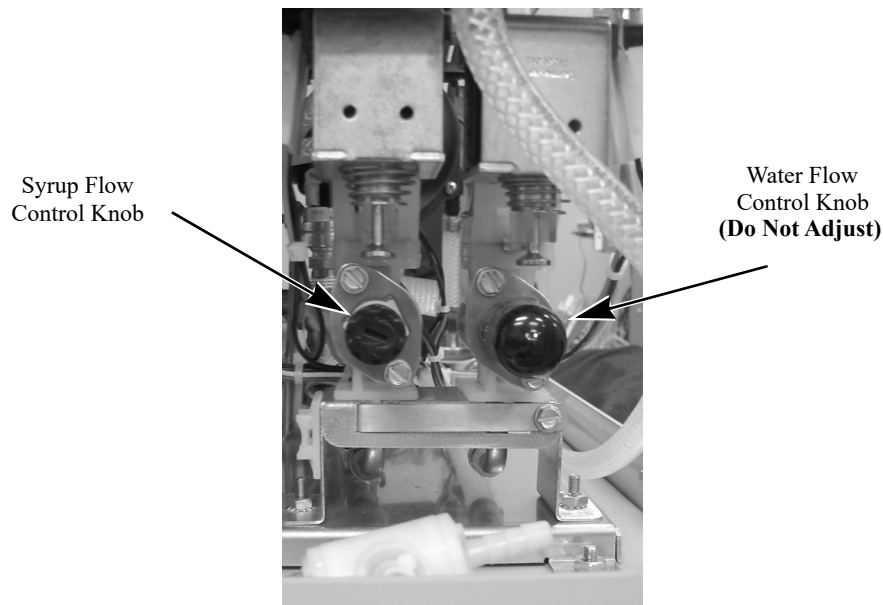

Figure 28.

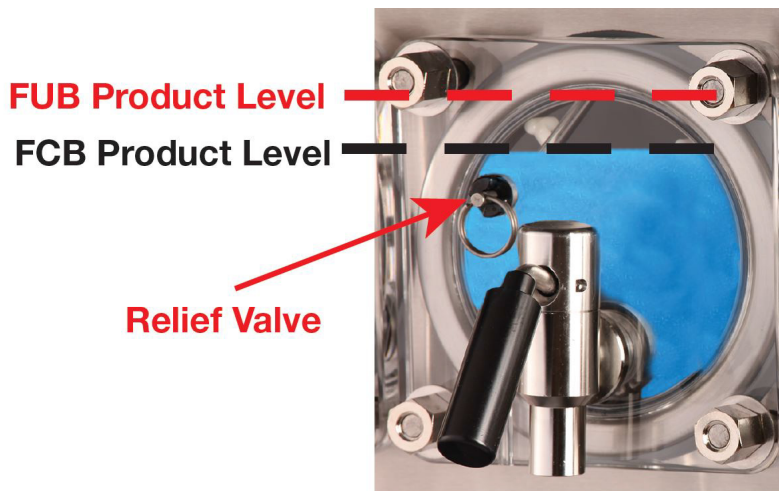

Figure 29.

Filling the Barrels

Once the barrels have been BRIXed and purged, they may be filled with product. This is accomplished by going to the Barrel Maintenance menu and pressing the FILL button. This starts the fill process for the highlighted barrel. As the barrel fills, the barrel pressure sensor shuts off the barrel at a pressure of 28 psi. To completely fill the barrel, open the relief valve on the faceplate of the barrel and allow some of the barrel pressure to escape. This allows the barrel to continue filling. Repeat this process until the product level is at the height indicated in based on product type. Once the product reaches the proper level, press the OFF button to stop filling the barrel. Press the FREEZE button to start mixing and cooling the product and the CO2 present in the barrel.

Calibrating a Motor

Motors are factory calibrated, but storage and transit can cause a shift in calibration. Calibration establishes a new baseline for the motor assembly. This allows the system to determine proper viscosity settings for the motor. As a part of installation, each barrel should be calibrated using the procedure in Table 24. and Table 25.

CAUTION:

Calibration must be performed when the product in the barrel is completely liquid. There must not be any ice on the scraper blade.

The Motor Setup Screen in Figure 30. allows you to select different motor types for each barrel in the unit and run the calibration procedure on that motor. This procedure correlates the actual viscosity of the barrel and its contents with the electrical characteristics of the motor. There are two options for Motor Type. Motor Type 1 is for 60 Hz units and motor type 2 is for 50 Hz units. The type of unit can be verified on the unit data plate. Perform the procedure described in Table 24. to verify the motor type setting.

NOTE: If the Motor Type shown is "DEFAULT", it indicates that the EEPROM is not installed or is faulty.

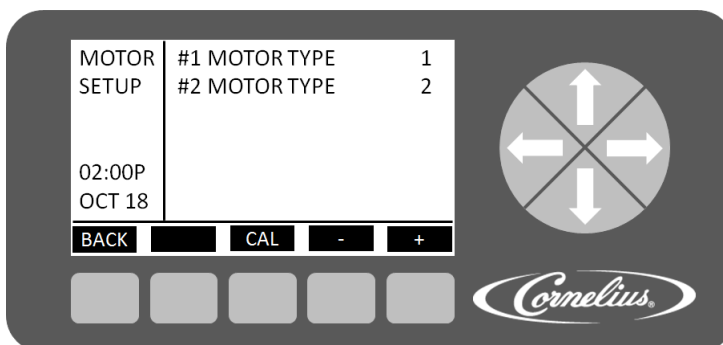

Figure 30. Motor Setup Screen

Table 24.

Step	Action	Procedure
1	Set barrel for Motor Type	From the Maintenance menu (Figure 31.), open the Motor Setup menu, shown in Figure 30.
2	Select the barrel	Use the Up and Down arrows to highlight the desired barrel
3	Select the proper motor type	Press the + or - buttons at the bottom of the display to set the motor type to 1 for 60 Hz or 2 for 50 Hz
4	Complete the procedure	Press the BACK button at the bottom of the display to save the settings and return to the Setup menu.

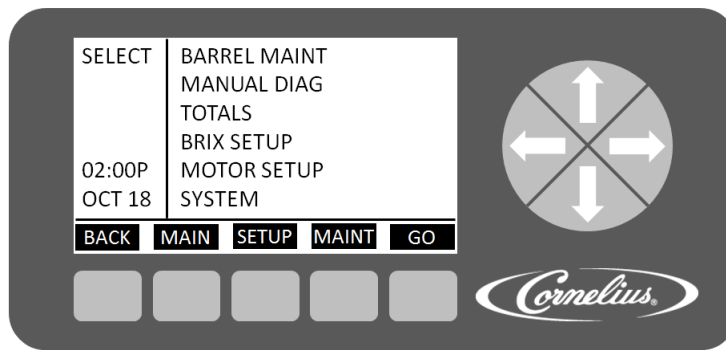

Figure 31. Select Screen

Table 25.

Step	Action	Procedure
1	Select Motor Setup	Use the Up and Down arrows to highlight MOTOR SETUP on the Maintenance menu.
2	Select the barrel	Use the Up and Down arrows to highlight the desired barrel
3	Start calibration	Press the CAL button at the bottom of the Motor Setup menu to start the calibration process. The calibration cycle continues for five (5) minutes to allow the gearbox to stabilize at temperature and ensure correct calibration. At that time the motor stops and it is calibrated.
4	Complete the procedure	Press the BACK button at the bottom of the display to return to the Maintenance menu.
5	Verify	Select SPIN to run the motor and visually ensure that the calibration reading is 20 +/- 2.

Security Menu

The security is enabled at the factory before shipping the Unit. It is recommended that security be remains enabled after installation.

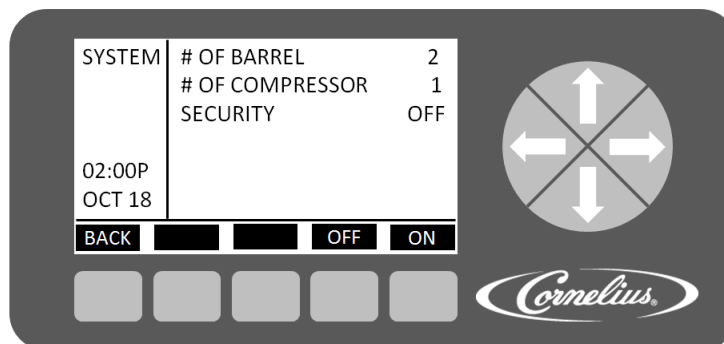

Figure 32.

Security Disabling: System security is located on the System menu. It allows a supervisor or service technician to keep unauthorized personnel from accessing the Maintenance menu. This feature is activated on the System menu. When security is turned on, users can only access the Main and Setup menus. The word LOCKED appears in the upper left corner of the display to inform users that security is enabled.

Pressing the extreme Left and Right buttons (Buttons 1 and 5) on the bottom of the display simultaneously and holding them for approximately five (5) seconds unlocks the Security menu. If security is left ON, on the System menu, when the system times out or when the user goes back to the Main menu, security is reactivated and the Maintenance menu is not accessible. To disable security, access the System menu, highlight Security and press the OFF button.

TROUBLESHOOTING

Problem	Probable Cause	Remedy
Unit will not run.	A. Unit not plugged in B. Circuit breaker	A. Plug in unit. B. Reset/replace circuit breaker
“Sleep” display on Barrel Status menu	A. Sleep time set B. Clock incorrectly set C. No or incorrect wake up time set	A. Check programming B. Check programming C. Check programming
Barrel Status OFF	A. Not activated B. Error has shut down barrels C. Unit in diagnostics	A. Turn barrels to ON or SPIN B. Correct error & turn barrels to ON C. Exit diagnostics & turn barrels ON
No water pressure	A. Water source not turned on B. Filter blocked C. Other	A. Turn on water B. Change filter C. Call Service



SPECIFICATIONS

Line Voltage:	215-245VAC
Max. Current Draw (FLA):	
2 Barrel Unit	16 amps
Max. Circuit Ampacity:	
2 Barrel Unit	20 amps
Syrup Tubing Size:	3/8 in. I.D., 75 ft.
Syrup Pressure:	75 psig (0.52 MPa)
Water Inlet Size:	1/2 in. I.D., 75 ft. max.
Water Flow Rate (2 barrel unit)	100 gal. per hr. at 25psig min. flowing pressure
Water Flow Rate (3 barrel unit)	100 gal. per hr. at 25psig min. flowing pressure
Water Flow Rate (4 barrel unit, low cap., single compressor)	100 gal. per hr. at 25psig min. flowing pressure
Water Pressure	25psig (0.17 MPa) min, 90 psig(0.62 MPa) max.
Ventilation Clearance, Standard Condenser	2" on both sides or back
.....	12" on top of the unit
Equipment Weight:	
2 Barrel Unit	410 lb.
CO ₂ Tubing Size:	3/8 in. I.D., 75 ft. max.
CO ₂ supply pressure to Viper should never exceed 75 psig (0.52 MPa)	
CO ₂ Pressures:	
To Unit	75±1 psig
To BIB Pumps	75 psig see Table 26.
To Barrels	(36-40 psig typically for FCB)
To Expansion Tank (non-adjustable)	30 psig
Product Flow Rate:	2 oz./sec.
BRIX:	13 ±1 standard
Viscosity Setting Range	1-9
Height:	37 in.
Width:	
2 Barrel Unit	17 in.
Depth (including drip tray):	32.5 in.
Operating Temperature:	55° to 95° F

Table 26. Recommended Syrup Pump Pressure Settings for Various Line Runs

		BIB Pump Set Pressure (psi)									
Vertical Rise (ft)	25	85	85	85							
	20	80	85	85	85	85	85				
	15	80	80	80	80	85	85	85	85		
	10	75	80	80	80	80	80	85	85	85	85
	5	75	75	75	75	80	80	80	80	80	85
	0	75	75	75	75	75	75	75	80	80	80
		10	20	30	40	50	60	70	80	90	100
		Length of Run (ft)									



(BLANK)

VIPER E 2 FLAVOR, R-454C SERVICE PROCEDURES



(BLANK)

INTRODUCTION

MANUAL OVERVIEW

The organization of this manual allows the user to scan quickly to the subject of interest along the left side of a page and to read the detail about the subject or procedure on the right side of the page. The manual provides the detail needed for newcomers to the industry while allowing experienced technicians to skip over the details and move quickly through the material.

This manual is designed as a guide to the technician in maintaining and servicing the Viper system. The Viper system is simple in design and has built-in features and diagnostic controls to help the service technician quickly and accurately service the machine.

The unit consists of multiple freeze barrels that each contain an internal beater driven by a rear mounted electric motor, a refrigeration system, timer-controlled, automatic hot gas defrost system and interconnecting tubing and controls required to dispense the product.

Some of the system features and functions are listed below:

- Simple User Interface LCD Display
- Real Time Clock
- Incoming Line Voltage Sensing
- Pressure Sensing of Incoming Water, Syrup and CO₂
- System Error Handling
- Error Log
- Viscosity Control

DISPENSED PRODUCT CONDITIONS

Overrun, as Applied to Carbonated Beverages

Overrun Definition

Overrun is defined as product expansion that takes place in the frozen carbonated drink. It is caused primarily by CO₂ gas breakout and secondarily by freezing.

Overrun is a Variable

The percentage or degree of overrun depends on a number of factors. The specific syrup, BRIX, low dispensing volume, carbonation level in the liquid product and freezing of the product. These items all affect overrun. After these factors have been considered, desired viscosity (product consistency) adjustment may be made on the unit. The viscosity adjustment adjusts product texture from very wet to light.

Specific Product Ingredients Affect Overrun

Each syrup has its own specific formulation of makeup. Fruit flavors contain citric acids that colas do not. Colas also differ in ingredients from one brand to another. Each product formulation has its own peculiarities regarding the way the product absorbs carbonation and the way it releases carbonation.

BRIX Affects Overrun

Sugar in carbonated drinks is like anti-freeze in water. The higher the BRIX, the greater the resistance of the product to freezing. Conversely, in products with lower BRIX, freezing takes place at higher temperatures than for high-BRIX products. Thus, BRIX affects overrun because the amount of sugar in a drink has a direct bearing on the product's freezing characteristics.



Low Dispensing Volume Affects Overrun

When a unit sits idle for a period of time with no drinks being dispensed, CO₂ gas in the system takes a "set". When the first few drinks are drawn off after an idle period, CO₂ gas has less tendency to break out as the drink is dispensed. The result is that these first drinks have less overrun than drinks dispensed during peak-use periods.

Carbonation Level in Liquid Product Affects Overrun

The higher the specific carbonation level in a given product, the greater the potential for carbonation breakout in frozen carbonated form of that drink. For example, drinks with 3.0 volume of carbonation have more gas breakout in frozen carbonated form and more overrun than drinks that contain 2.0 volumes of CO₂ gas.

Freezing Affects Overrun

Freezing causes approximately a 5-7 percent expansion in dispensed frozen carbonated drinks. The degree of freezing is limited because the finished drink is intended to be sipped through a straw. This is not possible if the product is too "solid".

SYSTEM OVERVIEW

INTRODUCTION

The Viper unit consists of the following systems and hardware:

Multiple freeze barrels, each containing an internal scraper bar driven by an AC motor.

A refrigeration system and an intelligent, hot gas defrost system.

The components are enclosed in a powder-coated steel frame to prevent corrosion. It is covered with ventilated cladding panels and a lighted merchandiser. The cladding is easily removable to facilitate installation, service and maintenance.

Each barrel has a transparent faceplate, with an integral relief valve and a removable, self-closing dispensing valve mounted on the front. A removable drip tray, with cup rest is located directly below the dispensing valves.

A programmable control system with a control panel that controls operational and diagnostic functions and settings is located behind the merchandiser.

THEORY OF OPERATION

The refrigeration system schematic is shown in Figure 33. It provides the basic configuration for the Viper refrigeration system.

The wiring diagram of the 2-Barrel Viper unit is shown in Figure 34.

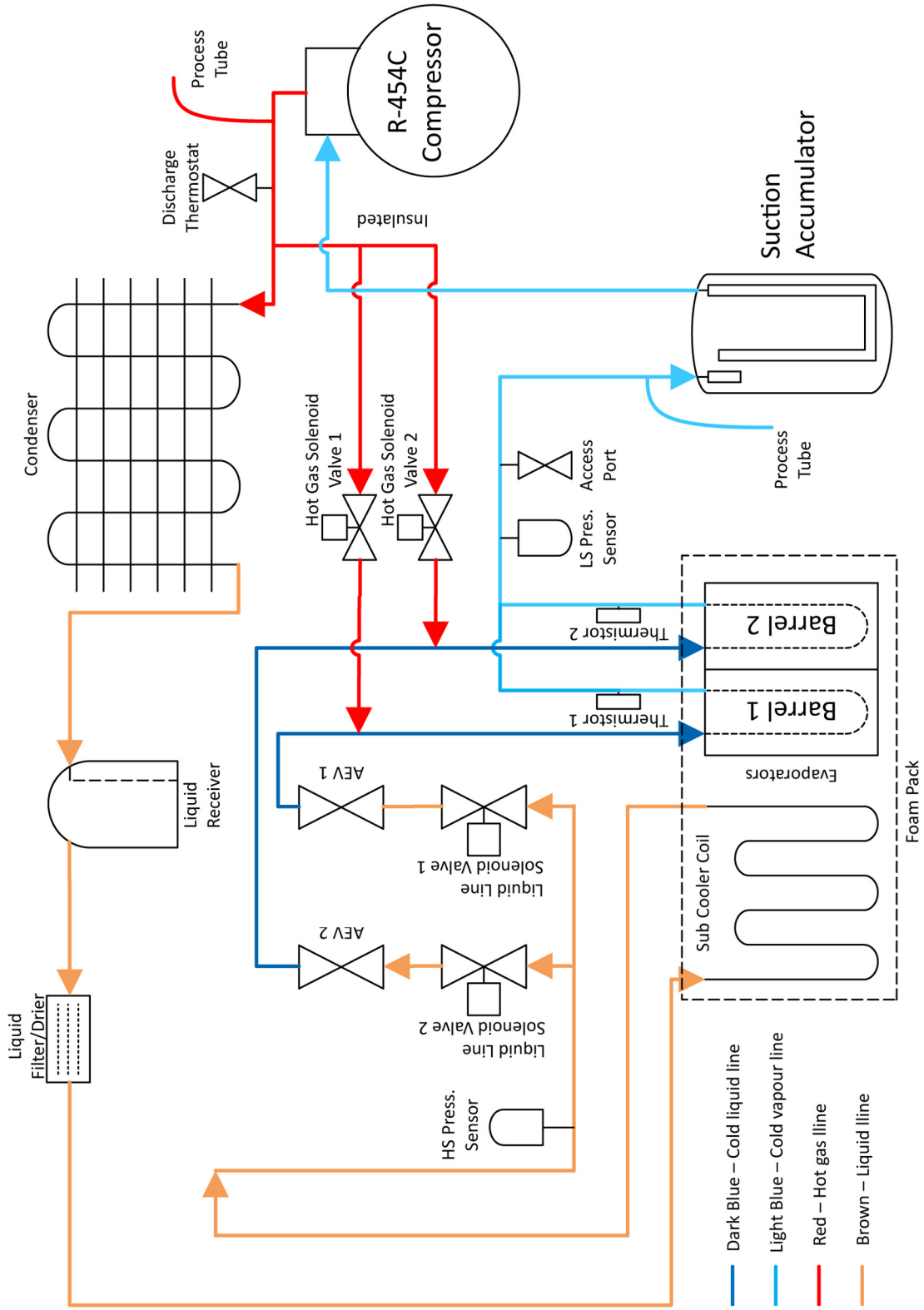
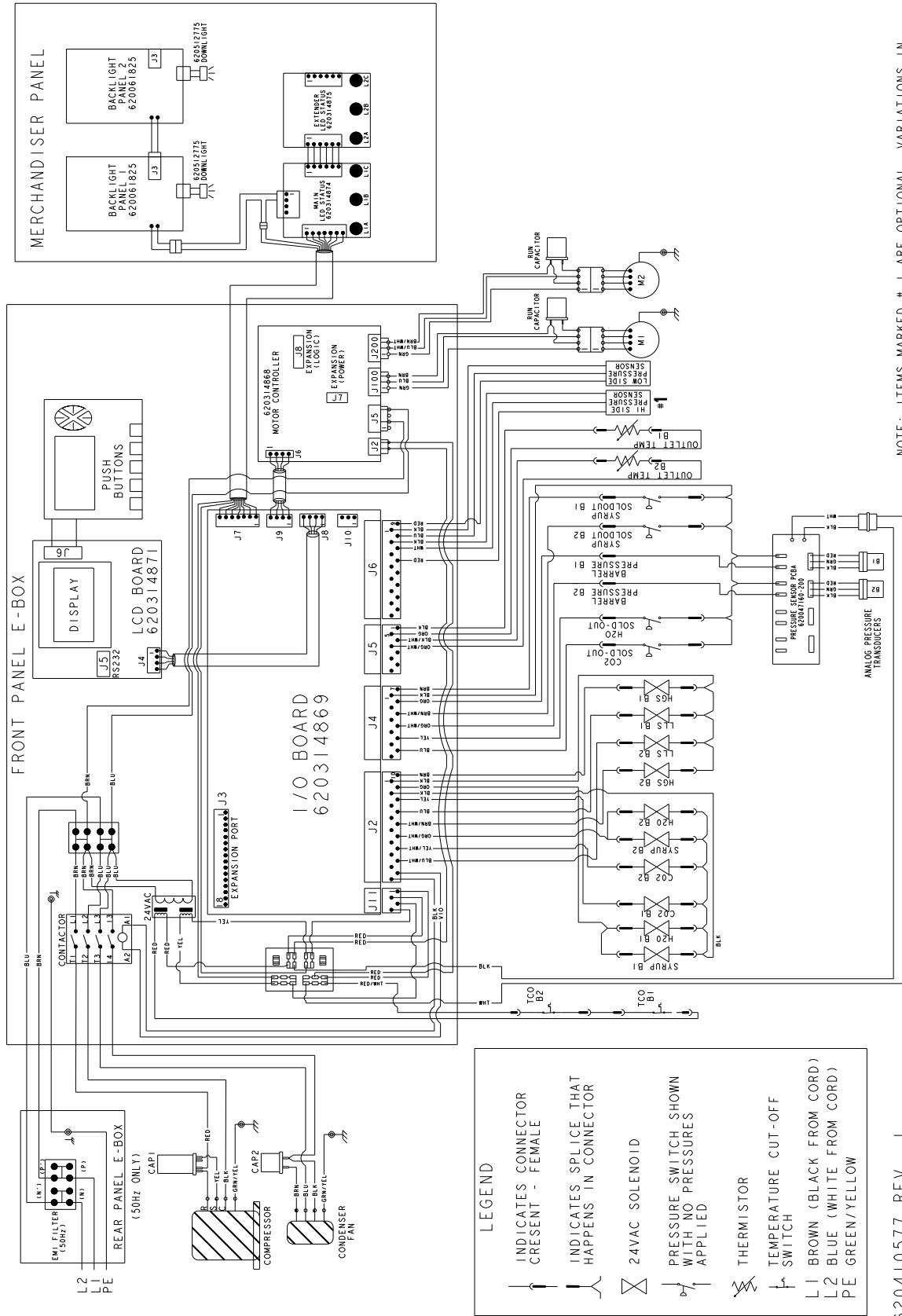

Figure 33. Viper System 2-Barrel Refrigeration-R454C Schematic



NOTE: ITEMS MARKED # 1 ARE OPTIONAL. VARIATIONS IN WIRING DEFINED IN THE TECHNICAL TIP # TT-15-4, REV. A.

620410577 REV. J

Figure 34. Viper 2-Barrel Wiring Diagram (W/Transducer)

*An overall schematic of the delivery systems contained in the unit are shown in Figures 36 and 37. The CO₂ system interacts with both the water and syrup systems. It provides pressure and carbonation for the syrup/water product mix.

CO₂ System

A CO₂ tank or bulk CO₂ supply delivers carbon dioxide gas (CO₂) to an adjustable secondary CO₂ regulator assembly that is attached to the tank as shown in Figure 35. The CO₂ system also supplies CO₂ to the water boost pump, the expansion tank regulator and the secondary CO₂ tank regulators.

CO₂ enters the expansion tank regulator and is reduced to approximately 30 psig to feed holding pressure on the expansion tank. This provides a force to work against the barrel pressure when the product freezes and expands.

CO₂ also enters the secondary regulators. These regulators are used to adjust barrel overrun/expansion for various products. The pressure settings for various types of syrup are shown in Table 27. Overrun CO₂ pressure is applied to the CO₂ control solenoids through preset orifices and on to the in-line check valves.

From the in-line check valve, the CO₂ flows into the product line.

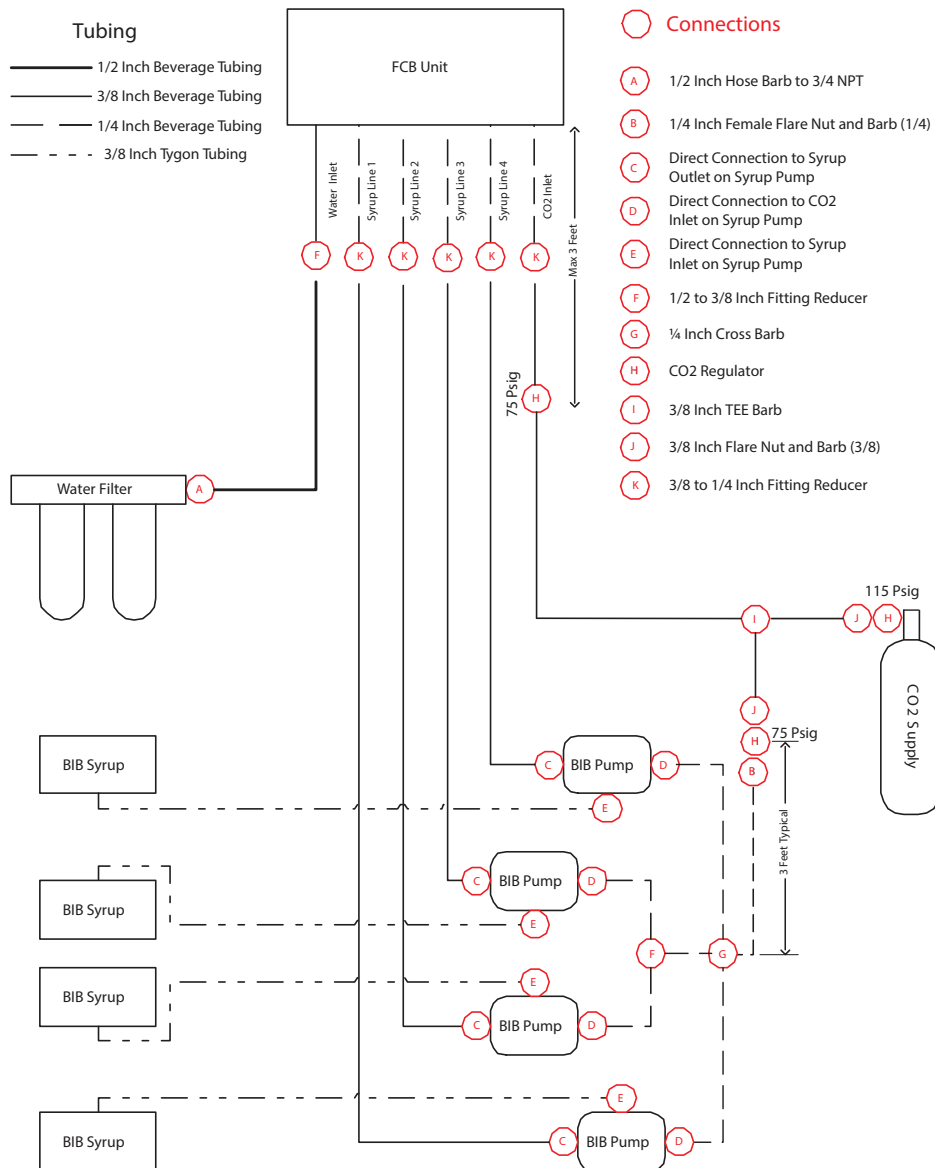

Figure 35. Cylinder CO₂ Connection

Table 27. provides guidelines for machine settings based on general syrup type. Several factors, including syrup formulation, level of citric acids, etc, will impact settings. These settings are to provide initial adjustments to achieve product overruns in the 80-120% range.

Table 27.

Syrup Type	Syrup Type Set	Viscosity	Pressure	Expansion
FCB Syrup w/ Foaming Agent	FCB	4	34-36 PSIG	30
FCB Syrup w/o Foaming Agent	FCB	4	32-36 PSIG	30
FUB	FUB	7	N/A	30

NOTE: For citric syrups, adjust the CO₂ pressures down by 2-4 PSIG from the above to compensate for the lower CO₂ adsorption.

VIPER PDEL 2 BARREL SCHEMATIC

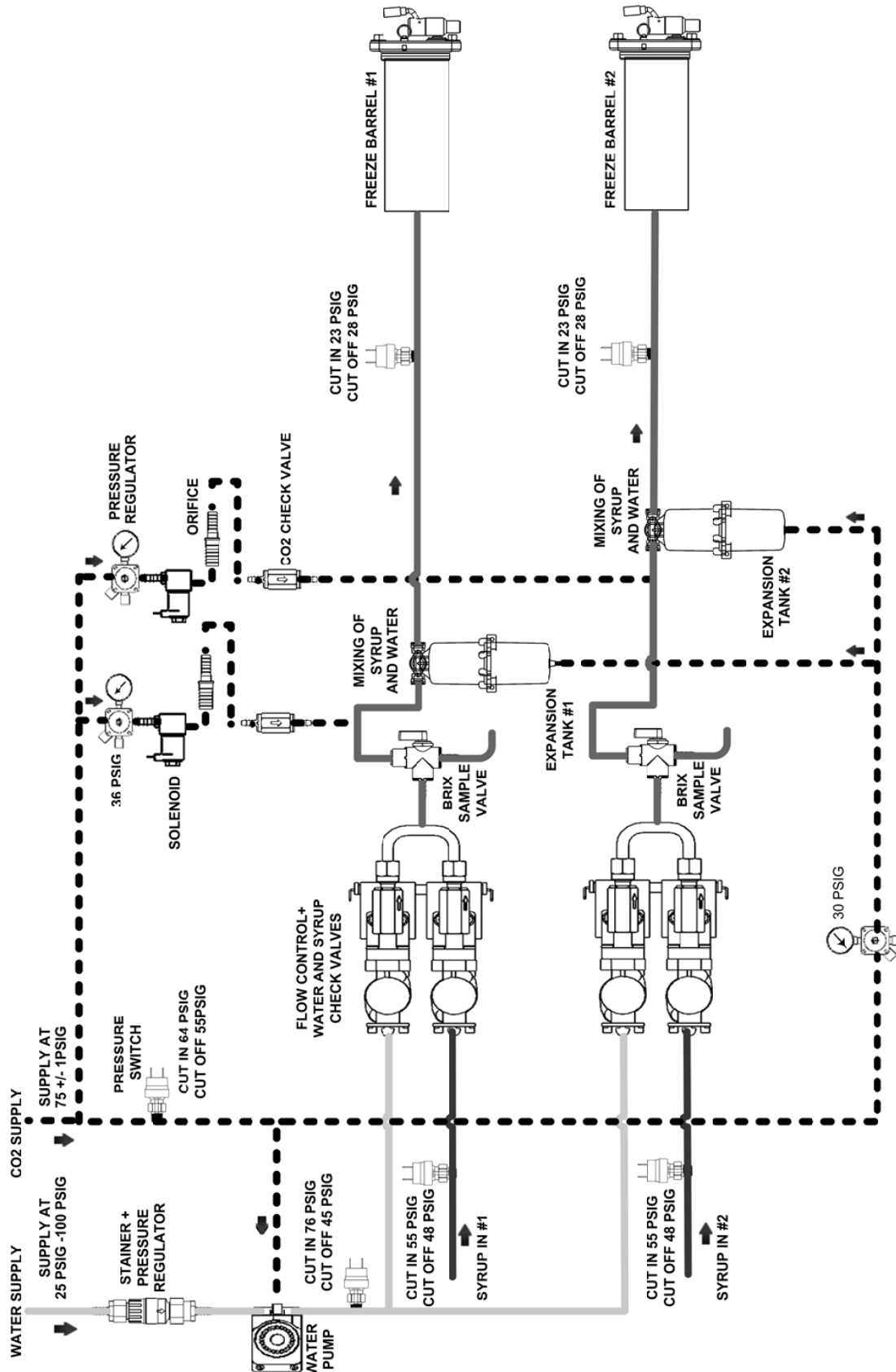

Figure 36. 2-Barrel System Schematic

Water System

Incoming water flows to a water pressure regulator that is preset to 30 psig. It flows through the water booster pump, to the regulator and through a sold-out switch.

Once through the boost pump, the water supply is split to each barrel and is fed to the water flow controls. From the flow rate control, the water passes through a single ball check valve and mixes with the syrup in a Y-fitting for injection into the freeze barrel.

Syrup System

Syrup enters the unit through a sold-out switch. It enters a similar flow control to the water system, passes through a single-ball check valve and into the Y-fitting where it meets the water for injection into the freeze barrel.

CONTROL PANEL

Introduction

The Viper unit uses a microprocessor based control system that monitors and controls all of the major systems and components of the machine. Temperatures and pressures are monitored, along with pumps, valves and the refrigeration system. They are managed by the control system to provide a consistently high quality product with optimal efficiency.

The control system is set up by the service provider to perform the tasks necessary to keep the Viper unit operating correctly. In addition to controlling the unit, the control system keeps track of the diagnostic information used when adjusting and/or repairing the machine.

The control system needs to be accessed in the following situations:

- Installing the Viper
- Modifying Operating Characteristics
- Checking Performance
- Servicing/Repairing the Machine
- Checking for Error Messages

The control system is accessed using the control panel located behind the lighted merchandiser. The control panel contains an LCD display and buttons shown in Figure 34.

There are 2 levels of access to the control panel: The first level can be accessed by the operator for normal operation and the second level is used by qualified service technicians for installation and service functions. The service functions can be secured (locked out) so that an operator does not have access to them. The control panel has a structured organization of menus. The outline of this structure is shown in Figure 38 The Maintenance sub-menu is not visible when the security feature is on.

The first menu that is displayed after the unit is powered up and stabilized is the BARREL STATUS or HOME menu, shown in Figure 37 This menu is displayed when the unit is running in normal operation.

Control Panel Display

The control panel display has two main areas. The first area is the menu display area. This area presents information about the status and settings of the machine. It also displays menus of actions that are taken to modify the functioning of the machine.

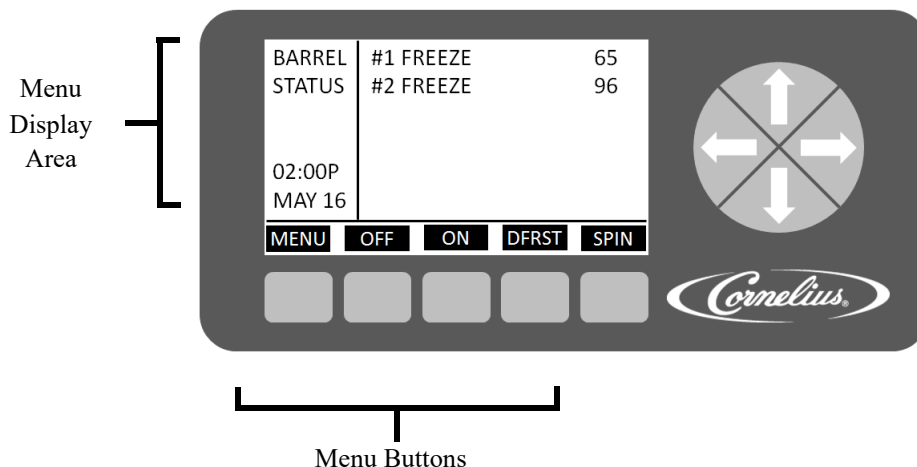

Figure 37. Control System Display

Control Panel Buttons

The second area are the buttons and arrows located across the bottom and on the right side of the control panel. There are up to five buttons and four directional arrows that may be used on a screen to activate and control various the functions of the system. Each button that is active for a given menu has a label directly above it. The label describes what that button controls. For example, from the Barrel Status menu, pressing button 1 (labeled MENU) displays the Select menu with more options — pressing button 3 (labeled OFF) turns off the highlighted barrel.

On each menu below the Select menu, there is a button (labeled BACK) to save any settings and return to the previous menu. There is another button (GO) to advance to the highlighted menu.

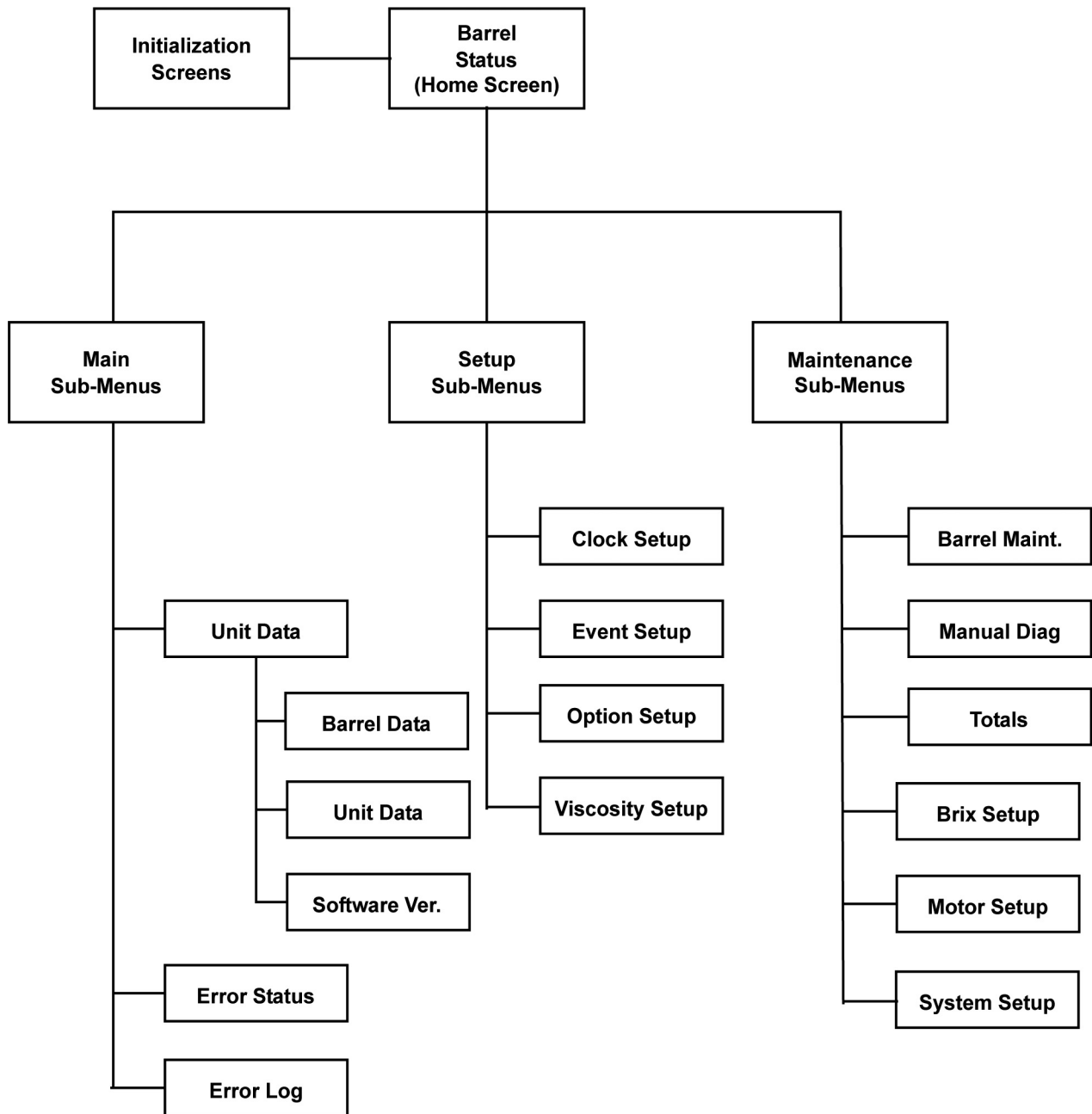

Figure 38. Software Structure

CONTROL PANEL MENU DESCRIPTIONS

The following section describes the information displayed on each control panel menu and the interactions and settings that are controlled by that menu.

System Menus

The system menu structure allows the user to control the unit through the control panel. Operational settings, optional parameters, troubleshooting and error information are controlled through this menu system.

The Barrel Status menu, shown in Figure 39, is the home screen for the unit. During normal operation, this screen is displayed on the control panel.

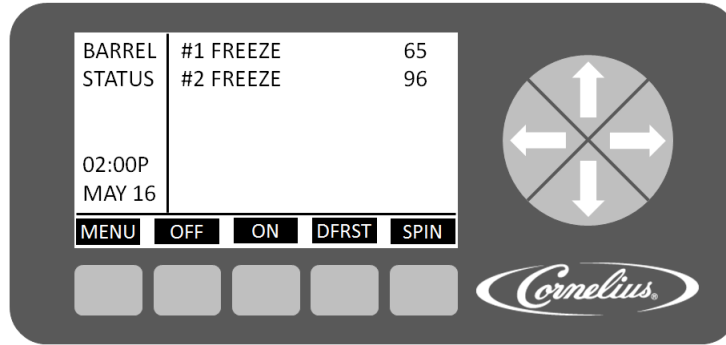

Figure 39. Main Screen

Table 28.

Button	Description
MENU	Displays the Main menu
ON	Turns on the highlighted barrel
OFF	Turns off the highlighted barrel
DFRST	Initiates a manual defrost on the highlighted barrel. Manual defrost is limited to a four minute cycle.
SPIN	Turns off refrigeration, if on and mixes the product in the barrel.

Main Menu

To access the menus for the system from the Barrel Status menu, press the MENU button. This displays the Select menu, shown in Figure 40. The Setup and Maintenance menus are accessed through the buttons shown at the bottom of the display.

NOTE: If security is turned on, the MAINT button is not displayed.

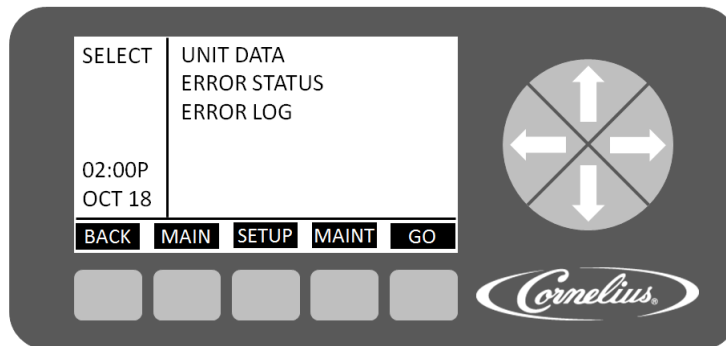

Figure 40. Select Screen

When the Select menu is displayed, the Unit Data is highlighted. To access the Unit Data menu, press the GO button. Refer to Table 29, the Select menu, for button functions.

Table 29.

Button	Description
BACK	Returns the display to the Barrel Status menu
MAIN	Highlighted to indicate current menu
SETUP	Opens the Setup menu
MAINT	Displays and opens Maintenance menu, if security is off or accessed
GO	Opens the highlighted selection on the current menu

Unit Data Menu

The Unit Data screen, shown in Figure 41, provides information about the individual barrels in the system. When DATA is highlighted and the GO button is pressed on the Select menu, the display shows the first barrel in the system and some of its parameters. To view the next barrel, press the down arrow on the right side of the display. Continue pressing the down arrow to view the data on all barrels in the system. Refer to Table 30 for button functions.



Figure 41. Unit Data Screen

Table 30.

Button	Description
BACK	Returns the display to the Select menu
BRL	Displays the data for a single barrel, including Outlet Temperature, Viscosity, if Refrigeration is On or Off, Average Ounces of product dispensed per hour for the last three hours and Defrost Lock Time until next defrost
UNIT	Displays the real time input voltage and frequency being supplied to the unit and the low, high or both refrigeration pressures for the unit, depending on the settings of the compressor sensors in the Unit Data screen.
VER	Displays the version number of the UI, I/O, Motor and Status boards installed in the unit

Error Status Menu

The Error Status menu, shown in Figure 42, displays any current errors contained in the Error Messages List.

There are three types of errors that can be generated by the system. These error types and a description of their meaning are listed in Table 31.

Table 31.

Error Type	Description
System	A System error displays the same information across all barrels in the unit.
Barrel	A Barrel error is limited to a specific barrel
Limp	A Limp error is an error that doesn't prevent the unit from operating, but limits functionality.

The possible messages from the control system and a description of the errors are shown in Table 32. The button functions are described in Table 33.

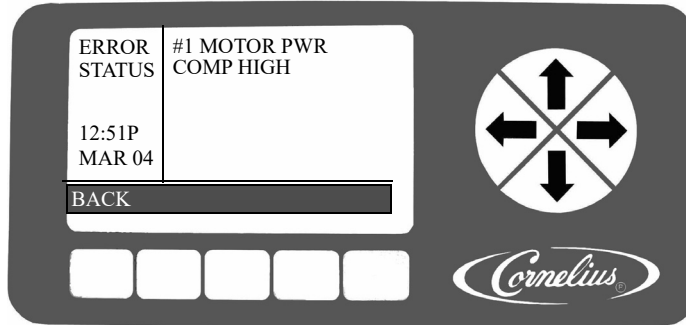

Figure 42. Error Status Screen

Table 32.

Displayed Message	Action	Type	Description
HOT GAS	Off	System	Occurs when the barrel outlet temperature exceeds 115 °F for more than one minute and the compressor is on.
HOT BARREL	Off	System	Occurs when the barrel outlet temperature exceeds 115 °F for more than one minute and the compressor is off.
MTR CTL FAIL		System	The motor controller reported a fault, triacs are shorted and there is a loss of motor on/off functionality.
TCO OPEN		System	TCO (Temperature Cut Off) has occurred on the refrigeration outlet of a barrel or the 24VAC power has failed.
COMM ERR IO		System	A communications error occurred between the IO board and the UI board.
COMM ERR MTR		System	UI board cannot communicate with the motor board.
BARREL REFRG		Barrel	Compressor has been on for more than 45 minutes and the viscosity of the barrel is not satisfied with no draws.
MTR CAL ERR		Barrel	Occurs if a calibration initiated from the Motor Setup menu fails. This indicates that the power draw of the motor is outside the allowable calibration range.
CMP HI-PRESS		System	This error is generated if the low side pressure is greater than 55 psi for greater than 30 sec. Only checked when barrels are in freeze mode and compressor is running more than two minutes.
BRL TEMP OUT		Barrel	Indicates thermistor reading is at min. or max. value for 30 sec. without changing.
MOTOR STALL		Barrel	Motor stalled. A two minute defrost and two retries are allowed, then the message is displayed,
METER FAIL		Barrel	Metering chip is nonresponsive.
BRL RECOVER		Barrel	Barrel viscosity is too high. Motor cannot rotate. Automatic two minute defrost to thaw barrel.

Table 32.

Displayed Message	Action	Type	Description
COM ERR STAT		Limp	Communications error, the system continues to run.
HIGH VOLTAGE		System	The unit is experiencing voltage greater than 260VAC. System is enabled when line voltage drops below 260VAC for two minutes.
LOW VOLTAGE		System	The unit is experiencing voltage less than 200VAC. System is enabled when line voltage rises above 200VAC for two minutes.
NO MOTOR		Barrel	The motor is reporting no current draw when activated. Motor is unplugged or thermal cutoff has tripped.
FILL ERROR		Barrel	Barrel has not filled properly within 2 min.
H2O OUT		System	Water pressure is too low for proper operation. This error occurs when the H2O sensor reports no or low water pressure for more than one second. Error is cleared 10 sec. after restoral.
CO2 OUT		System	CO2 pressure is below required operating pressure. This error occurs when the CO2 sensor reports no or low CO2 pressure for more than one second. Error is cleared 10 sec. after restoral.
SYRUP OUT		Barrel	Syrup pressure is below required operating pressure. This error occurs when the syrup sensor reports no or low syrup pressure for more than one second. Error is cleared 10 sec. after restoral.
CLOCK		System	The real time system clock is not functioning.
MTR CTL EEPROM		System	Motor control EEPROM is bad or missing.

Table 33.

Button	Description
BACK	Returns the display to the Select menu
RESET	Allows the user to reset the highlighted error (This button only appears on certain manually resettable errors.)

Error Log Menu

The Error Log screen displays information about any errors generated by the unit, as shown in Figure 43. If no errors have been detected, the right side of the display is blank. To view more than one error, press the Up or Down arrows on the right side of the display to scroll through the error log. Button functions are described in Table 34.

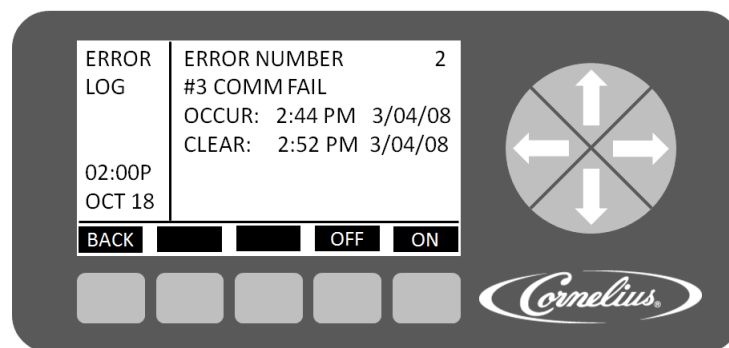

Figure 43. Error Log Screen

Button	Description
BACK	Returns the display to the Select menu

Setup Menu

The Setup menu provides the means to change various settings to local preferences, such as time, date and temperature formats. It also allows the user to adjust the unit for the type of syrup being served in each barrel.

To access the Setup menu from the Barrel Status menu, press the MENU button. This displays the Select menu, shown in Figure 44. Press the SETUP button to display the Setup menu. To set up the unit options, use the Up and Down arrows on the right side of the control panel to highlight the choices on the display. When the desired option is highlighted, press the GO button to access that menu.

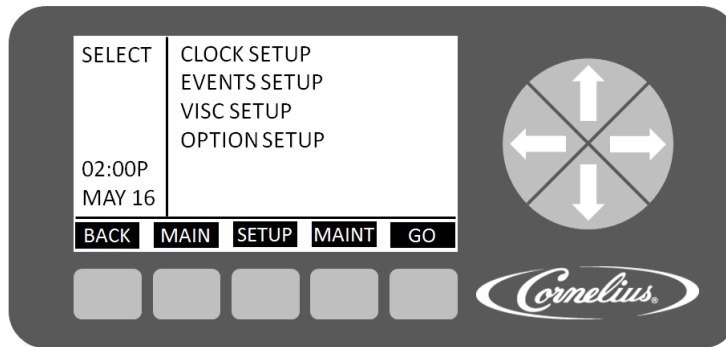

Figure 44. Setup Screen

Table 34.

Button	Description
BACK	Returns the display to the Select menu
MAIN	Opens the Main menu
SETUP	Highlighted to indicate that the Setup menu is displayed
MAINT	Displays button and opens Maintenance menu, if security is off or accessed
GO	Opens the highlighted selection on the current menu

Clock Setup Menu

Select the CLOCK SETUP menu from the Select menu, shown in Figure 44. This displays the Clock Setup menu, shown in Figure 45. Button functions are described in Table 35.

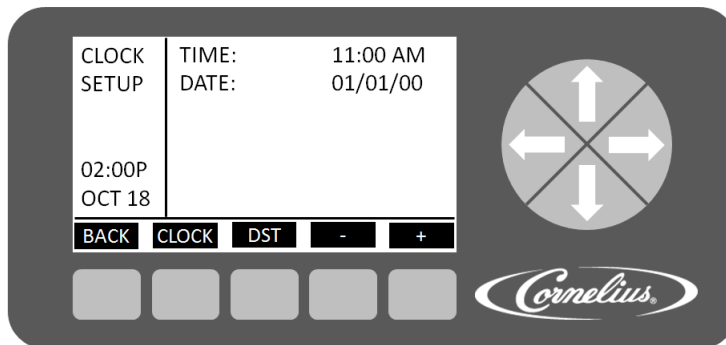

Figure 45. Clock Setup Screen

Table 35.

Button	Description
BACK	Returns the display to the Select menu
CLOCK	Highlighted to indicate that the Clock menu is displayed
DST	Opens the Daylight Savings Time menu
-	Decrements the highlighted field
+	Increments the highlighted field

Setting the Clock

To set the time, perform the procedure in Table 36.

Table 36.

Step	Action	Procedure
1	Set clock time	Use up and down arrows on the right side of the control panel to highlight TIME display on screen.
2	Select hour field	Use the left and right arrows to select hour field
3	Set correct hour	Use the + or - buttons at the bottom of the display to set the proper hour.
4	Select minute field	Use the left and right arrows to select minute field.
5	Set correct minute	Use the + or - buttons at the bottom of the display to set the proper minute.
6	Select AM/PM field	If the 12 hour clock option is selected, use the left and right arrows to select the AM/PM field.
7	Set AM/PM	Use the + button at the bottom of the display to set the AM/PM setting.

To set the date, perform the procedure in Table 37.

Table 37.

Step	Action	Procedure
1	Set date	Use up and down arrows on the right side of the control panel to highlight DATE display on screen.
2	Select month field	Use the left and right arrows to select month field
3	Set correct month	Use the + or - buttons at the bottom of the display to set the correct month.
4	Select day field	Use the left and right arrows to select day field.
5	Set correct day	Use the + or - buttons at the bottom of the display to set the correct day.
6	Select year field	Use the left and right arrows to select year field.
7	Set correct year	Use the + or - buttons at the bottom of the display to set the correct year.

Setting Daylight Savings Time

Once the date and time are set properly, daylight savings time settings can be done. The Daylight Savings Time menu is shown in Figure 46. If daylight savings time is off, press the + button to activate it. The button functions are described in Table 38. To set daylight savings time, perform the procedure in Table 39.

NOTE: Default daylight savings settings are for the U.S.

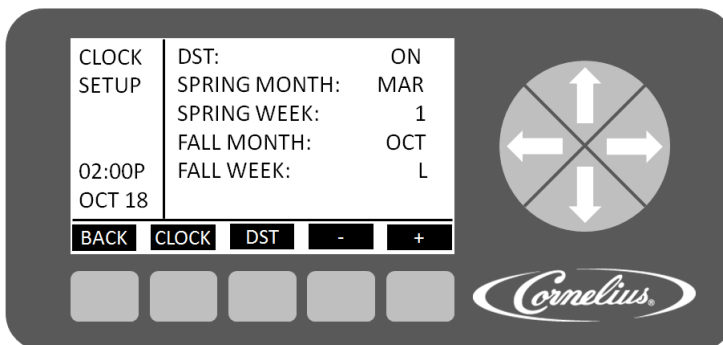

Figure 46. Daylight Savings Setup Screen

Table 38.

Button	Description
BACK	Returns the display to the Select menu
CLOCK	Opens the Clock menu
DST	Highlighted to indicate DST menu
-	Decrements the highlighted field by one increment
+	Increments the highlighted field by one increment

Table 39.

Step	Action	Procedure
1	Set daylight savings time	Press DST button at the bottom of display to open daylight savings time display, shown in Figure 46.
2	Select DST	Use the up and down arrows to select DST.
3	Set DST on	Use the + button to turn on daylight savings time.
4	Select SPRING MONTH	Use up and down arrows to select SPRING MONTH.
5	Set SPRING MONTH	Use the + or - buttons at the bottom of the display to set the correct month.
6	Select SPRING WEEK	Use up and down arrows to select SPRING WEEK.
7	Set SPRING WEEK	Use the + or - buttons at the bottom of the display to set the correct week. The choices are 1, 2, 3 or L.
8	Select FALL MONTH	Use the up and down arrows to select FALL MONTH.
9	Set FALL MONTH	Use the + or - buttons at the bottom of the display to set the correct month.
10	Select FALL WEEK	Use up and down arrows to select FALL WEEK.
11	Set FALL WEEK	Use the + or - buttons at the bottom of the display to set the correct week. The choices are 1, 2, 3 or L.

When the daylight savings settings are complete, press the BACK button to save the settings and return to the Select menu.

The Events Setup menu, shown in Figure 47, allows the user to set sleep periods for the unit and to lock out the defrost cycle during peak busy times. Sleep periods and defrost lockouts may be programmed for any day of the week or for all days of the week, depending on business requirements. Button functions are described in Table 40.

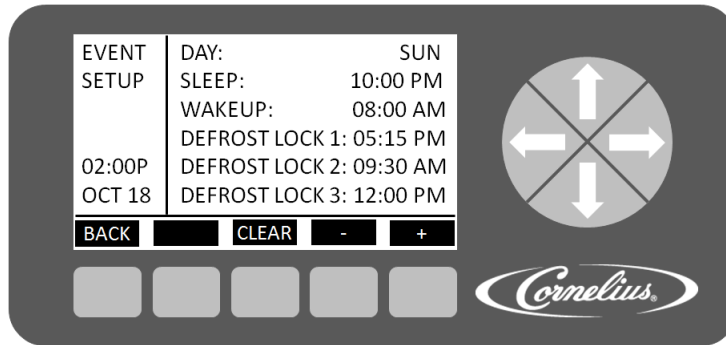

Figure 47. Event Setup Screen

Table 40.

Button	Description
BACK	Returns the display to the Select menu and saves current settings
CLEAR	Clears the highlighted field on the menu
-	Decrements the highlighted field
+	Increments the highlighted field

When the sleep and wake up settings and the defrost lockout settings are complete, press the BACK button to save the settings and return to the Select menu.

Setting Events

Events setup allows the user to set sleep periods for the unit and to lock out the defrost cycle during peak busy times. Sleep periods and defrost lockouts may be programmed for individual days of the week or for all days of the week, depending on location requirements.

Setting the Sleep and Wake up Times

Sleep and wake up times are set on the Event Setup menu. To set the sleep and wake up times, perform the procedure in Table 41.

When the unit goes into a sleep period, the barrel automatically defrosts for four minutes. Also, if a barrel is off when the sleep cycle starts, the barrel continues to be in the off state when the sleep cycle ends. If a barrel is running when the sleep cycle starts, the barrel starts back up when the sleep cycle ends.

Wake up should be scheduled for approximately one hour before product is required.

NOTE: Setting the sleep time after midnight requires you to set it during the next day. (i.e. Saturday night at 1am must be set as 1am on Sunday, etc.) If this type of setting is required, you cannot set another sleep cycle during that following day, i.e. Sunday.

Table 41.

Step	Action	Procedure
1	Set sleep and wake up times	Open the Events Setup menu, shown in Figure 47 by pressing the GO button.
2	Select DAY	The DAY field is highlighted.
3	Set DAY	Use the + or - buttons at the bottom of the display to set the desired day or all days.

Table 41.

Step	Action	Procedure
4	Select SLEEP	Use the up and down arrows to highlight SLEEP.
5	Set hour field	Use the left and right arrows to select the hour field and press the + or - buttons to change the hour.
6	Set minute field	Use the left and right arrows to select the minute field and press the + or - buttons to change the minutes (15 min. increments)
7	Select AM/PM field	If the 12 hour clock option is selected, use the left and right arrows to select the AM/PM field. Then press the + or - buttons to change between AM and PM.
8	Select DAY for Wake up	Repeat Steps 2 and 3 as needed.
9	Select WAKEUP	Use the up and down arrows to highlight WAKEUP and repeat Steps 5 through 7 to set the WAKEUP times.

When the sleep and wake up settings are complete, press the BACK button to save the settings and return to the Select menu.

Setting Defrost Lockout

From the Barrel Status menu, shown in Figure 39, press the MENU button and then press the SETUP button to display the Setup menu. Use the up and down arrows on the right of the control to highlight the Events Setup menu, then press GO to enter the menu.

The lockout can also be set day by day or for all days with up to three lockout periods of three hours each per day. These lockout periods may be overlapped to provide from three to nine hours of defrost lockout, if desired. When the periods are overlapped, it is recommended that the defrost lockouts for sequential lockout periods be overlapped by 15 minutes. The defrost lockout affects all barrels in the unit. To set the defrost lockouts, perform the procedure in Table 42.

Table 42.

Step	Action	Procedure
1	Set defrost lockout	Open Events Setup menu, shown in Figure 47.
2	Select DAY	The DAY field is highlighted.
3	Set DAY	Use the + and - buttons at the bottom of the display to set the desired day or all days.
4	Select DEFROST LOCK 1	Use the up and down arrows to highlight DEFROST LOCK 1.
5	Set hour field	Use left and right arrows to select hour field
6		Use the + and - buttons at the bottom of the display to set the desired hour.
7	Set minute field	Use left and right arrows to select minute field
8		Use the + and - buttons at the bottom of the display to set the desired minute (in 15 min. increments).
9	Select AM/PM field	If the 12 hour clock option is selected, use the left and right arrows to select the AM/PM field.
10		Use the + button at the bottom of the display to set the AM/PM field.
11	Select DEFROST LOCK 2	Repeat Steps 2 through 10 for the DEFROST LOCK 2 time, if desired.
12	Select DEFROST LOCK 3	Repeat Steps 2 through 10 for the DEFROST LOCK 3 time, if desired.

When the defrost lockout settings are complete, press the BACK button to save the settings and return to the Select menu, shown in Figure 44.

Viscosity Setup Menu

The viscosity maintained in the freeze barrels depends on the type of product being served. Some products are served best at a higher viscosity, while others require a lower viscosity for best quality. The Viscosity menu, shown in Figure 48, allows the user to adjust the viscosity in each barrel to the optimum setting for each type of syrup.

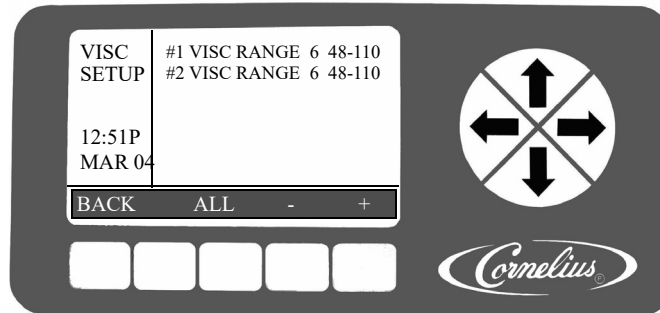

Figure 48. Viscosity Setup Screen

Refer to the Installation manual for the recommended settings based on syrup type.

Table 43.

Step	Action	Procedure
1	Set viscosity range	From the Setup screen (Figure 44.), open the Viscosity Setup screen, shown in Figure 48.
2	Select barrel	Use the Up and Down arrows to highlight the desired barrel.
3	Select range field	Use Left and Right arrows to select range field
4	Set range	Use the + or - buttons at the bottom of the display to set the desired range.
5	Select barrel	Repeat Steps 2 through 4 for all barrels.

To set all barrels in the system to the same viscosity setting, perform Steps 1 through 4 in Table 43, and then press the ALL button at the bottom of the display while highlighting the viscosity setting you desire for all the barrels. When the viscosity settings are complete, press the BACK button to save the settings and return to the Select menu.

Options Setup Menu

The Option Setup menu allows the user to set the various options available in the system. These options are listed in Table 44. The Option Setup menu is shown in Figure 49.

The functions of the display buttons change, depending on the highlighted selection on the Option Setup screen. Refer to Table 44 for a listing of the button functions for the various field selections.

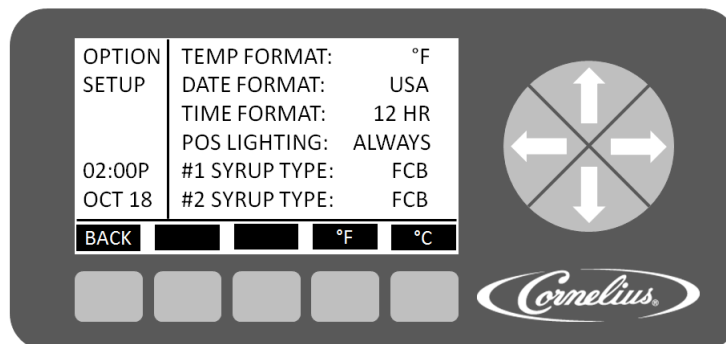

Figure 49. Option Setup Screen

Table 44.

Option	Button 2	Button 3	Button 4	Button 5
Temp Format			°F	°C
Date Format			USA	EURO
Time Format			12 HR	24 HR
POS Lighting		OFF	ALWAYS	SLEEP
#1 SYRUP TYPE	FCB	FCB-L	FUB	FUB-L
#X SYRUP TYPE	FCB	FCB-L	FUB	FUB-L

When all the options are set to the desired settings for the unit, press the BACK button to store these settings and return to the Select menu.

Setting the Temperature Format

The temperature format displayed by the unit may be set to either Centigrade or Fahrenheit. Press the °F button to display readings in Fahrenheit and press the °C button to display readings in Centigrade.

Setting the Date Format

The date format can be displayed in either United States or European format. To display U.S. date format, press the USA button. This displays the date in mm/dd/yy format. Press the EURO button to display the date in dd/mm/yy format.

Setting the Time Format

Time format can be displayed in either 12 or 24 hour format. To display the clock settings in 12 hour format (1:08 P), press the 12 HR button. To display settings in 24 hour format (23:05), press the 24 HR button.

Setting the POS Lighting

POS Lighting is controlled by the POS LIGHTING field on the Option Setup menu (Figure 49). To turn off the merchandiser lighting, press the OFF button while the POS LIGHTING field is highlighted. To turn on the merchandiser lighting permanently, press the ALWAYS button. To turn the merchandiser lighting on and off with the Sleep settings, press the SLEEP button.

Setting the Type of Syrup

Syrup type for each barrel may be selected by highlighting the desired barrel and pressing the appropriate button, FCB, FCB-L, FUB or FUB-L. FCB is for Frozen Carbonated Beverage, FCB-L is for Frozen Carbonated Beverages - Light (diet), FUB is for Frozen Uncarbonated Beverages and FUB-L is for Frozen Uncarbonated Beverages - Light (diet). Each of these settings provides the proper viscosity and temperature settings for the type of syrup being used.

Maintenance Menu

The maintenance menu, shown in Figure 51 is only available to service personnel or other authorized users, if security is enabled.

The Maintenance menu is used for barrel maintenance, diagnostics, BRIX setup and system information. It allows the technician access to the unit during periodic maintenance or troubleshooting problems. It sometimes overrides the normal inputs from the system in order to perform this task.

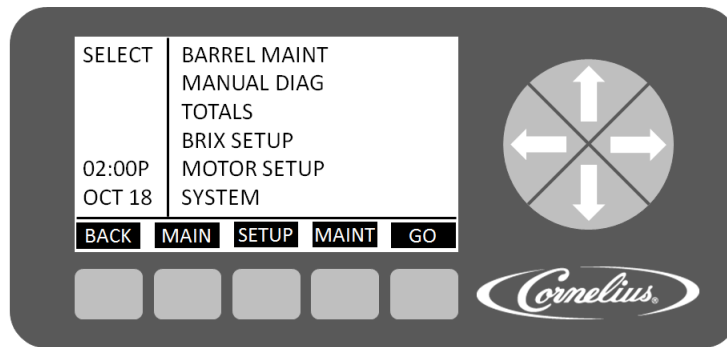

Figure 50. Select Screen

Barrel Maintenance Menu

The Barrel Maintenance menu, shown in Figure 51, allows the service technician to clean, rinse and sanitize the system on a barrel by barrel basis. The barrel must be OFF in order to perform the barrel maintenance functions. As a warning to the technician, the “Do Not Drink” status indicators are illuminated on the barrels when entering the Barrel Maintenance menu.

The procedure for purging a barrel is shown in Table 45. The procedure for filling a barrel is shown in Table 46. The procedure for running a barrel motor is shown in Table 47 and the procedure for rinsing a barrel is shown in Table 48.

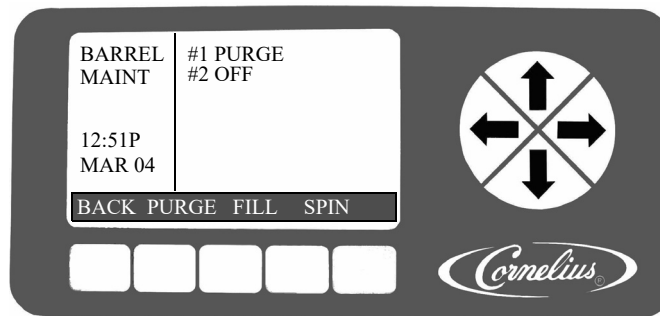

Figure 51. Barrel Maintenance Screen

Purging a Barrel

NOTE: When the PURGE button is pressed, it changes to a STOP button.

Table 45.

Step	Action	Procedure
1	Purge a barrel	From the Select menu (), open the Barrel Maintenance menu, shown in Figure 51.
2	Select the barrel	Use the Up and Down arrows to highlight the desired barrel
3	Select Purge function	Press the PURGE button at the bottom of the display to select purge for the high-lighted barrel
4	Empty the barrel	Place a container under the barrel dispensing valve, open the dispensing valve and dispense all the product from the barrel. As the product level lowers in the barrel, partially close the valve to avoid spurting.
5	Complete the procedure	When the barrel is completely empty, close the dispensing valve and press the STOP button at the bottom of the display to turn off the purge. Press the BACK button to return to the Select menu.

Filling a Barrel

Table 46.

Step	Action	Procedure
1	Fill a barrel	From the Select menu (), open the Barrel Maintenance menu, shown in Figure 51.
2	Select the barrel	Use the Up and Down arrows to highlight the desired barrel
3	Select Fill function	Press the FILL button at the bottom of the display to fill the highlighted barrel
4	Finish filling the barrel	When the fill completes, intermittently open and close the relief valve to bleed CO ₂ from the barrel.
5	Complete the procedure	Press the STOP button at the bottom of the display to stop the fill. Press the BACK button to return to the Select menu.

NOTE: When FILL button is pressed, it changes to a STOP button.

Run the Barrel Motor

Table 47.

Step	Action	Procedure
1	Run a barrel	From the Setup menu (), open the Barrel Maintenance menu, shown in Figure 51.
2	Select the barrel	Use the Up and Down arrows to highlight the desired barrel
3	Select Run function	Press the SPIN button at the bottom of the display to start the motor in the highlighted barrel
4	Stop the procedure	Press the STOP button at the bottom of the display to stop the motor. Press the BACK button to return to the Select menu.

NOTE: When RUN button is pressed, it changes to a STOP button.

Rinsing a Barrel

When rinsing a barrel, the Barrel Maintenance menu cannot be used. The procedure must be done manually, as described in Table 48.

Table 48.

Step	Action	Procedure
1	Empty a barrel	If the barrel has liquid in it, use the Purge procedure in Table 45 to empty the barrel.
2	Rinse a barrel	Go to the Barrel Status menu, Figure 39.
3	Select the barrel	Use the Up and Down arrows to highlight the desired barrel
4	Turn off the barrel	Press the OFF button at the bottom of the display to turn off the barrel.
5	Override Water Solenoid	Press the manual bypass on the water solenoid and fill the barrel with plain water. Use the relief valve on the faceplate of the barrel to relieve pressure and completely fill the barrel.
6	Run the barrel motor	Use the procedure in Table 47 to run the barrel.

Table 48.

Step	Action	Procedure
7	Complete the procedure	Repeat the Purge procedure in Table 45 to empty the barrel.

Manual Diagnostic Menu

The Manual Diagnostic menu, shown in Figure 52, is used for troubleshooting and testing the system on a component basis. It allows the service technician to turn individual components of the system on and off for troubleshooting purposes. Pressing the BACK button returns the display to the Main menu and turns off all the active loads.

This screen should only be used by qualified technicians to troubleshoot the system.

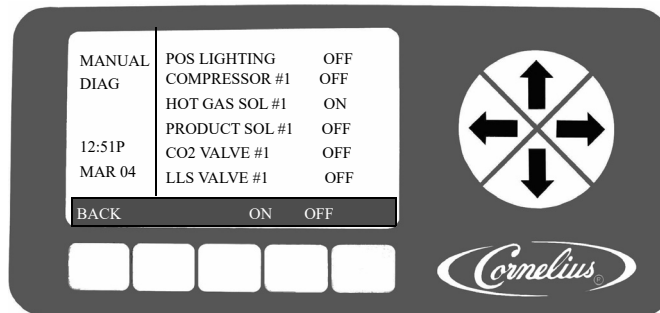

Figure 52. Manual Diagnostic Screen

The items shown in Table 49 are for the first barrel in the unit only. The list includes additional components with their related barrel number, i.e. Hot Gas Sol #2, etc.

CAUTION:

The compressor can suffer damage if it is allowed to run without either a hot gas defrost or liquid line solenoid open. The software is designed to turn on the hot gas solenoid for a barrel to prevent damage from occurring.

Table 49.

Display	Description
POS LIGHTING	This selection turns the Point-Of-Sale lighting on and off
COMPRESSOR #1	This selection turns the compressor on and off
HOT GAS SOL #1	This selection opens and closes the hot gas solenoid for barrel 1
PRODUCT SOL #1	This selection opens and closes the product solenoids and valves for barrel 1
CO2 VALVE #1	This selection opens and closes the CO2 solenoid and valve for barrel 1
LLS VALVE #1	This selection opens and closes the Liquid Line solenoid and valve for barrel 1
BRL MOTOR #1	This selection turns the barrel 1 motor on and off

To move between one set of barrel parameters to the next, press the Right or Left arrow keys. This moves the highlight to the first entry of the second barrel, etc.

Totals Menu

The Totals screen (Figure 53) shows the cumulative run time of the system, a component of the system or an error. Some individual items may be reset, where available, by highlighting the item and pressing the RESET button. The RESET button is only displayed for items that may be reset, such as hours since the motor seal was changed or the number of compressor

cycles. Pressing the BACK button returns to the Choose menu and saves the changes. The description of each item in the Totals list is shown in Table 50.

To move between one set of barrel parameters and the next, press the Right or Left arrow keys. This highlights the first entry of the second barrel, etc.

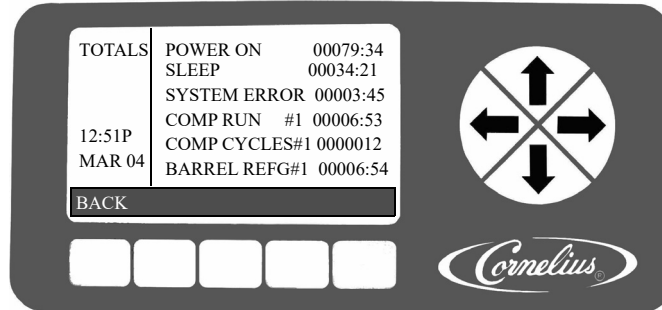

Figure 53. Totals Screen

Table 50.

Display	Value	Description
POWER ON	HHHHH:MM	Shows how long the machine has been powered up
SLEEP	HHHHH:MM	Shows how long the machine has been in sleep mode
SYSTEM ERROR	HHHHH:MM	Shows how long the machine has had a system error
COMP RUN #1	HHHHH:MM	Shows how long the compressor has been running since the last reset
COMP CYCLES #1	#####	Shows the number of compressor cycles since the last reset
BARREL REFG #1	HHHHH:MM	Shows how long the barrel has been in refrigeration mode
MOTOR ON #1	HHHHH:MM	Shows how long the motor has been running on a specific barrel
MOTOR SEAL #1	HHHHH:MM	Shows how long it has been since the motor seal was inserted on a specific barrel
DEFROST #1	HHHHH:MM	Shows how long the barrel has been in defrost mode
FILL CYCLES #1	#####	Shows the number of times the barrel has filled with product
SYRUP RUN #1	HH:MM:SS	Shows how long the syrup solenoid has been open
SYRUP OUT #1	HHHHH:MM	Shows how long the syrup has been out
ERROR #1	HHHHH:MM	Shows how long the barrel has had an error

BRIX Setup Menu

BRIX is important to the quality of the final product. The BRIX menu facilitates the extraction of a sample of product from the unit for BRIX measurement. There is an automatic three second dispense of product that produces a constant volume so that a BRIX comparison can be made between samples. To perform a BRIX test, perform the procedure in Table 51.

Table 51.

Step	Action	Procedure
1	Set status of barrels	Make sure the status of all barrels is OFF on the control display.
2	Remove drip tray/Splash panel	For classic model remove the drip tray, loosen the two screws holding the splash panel and remove it. (Fig. 55). For Carbon model prior to removing drip tray, remove splash panel and drip tray cladding and then loosen the two screws holding the splash panel and remove it.
3	Set product supply valve	Turn product supply valve to the 180 degree (BRIX) position for the barrel you are testing. (See Figure 57).
4	Access BRIX menu	Press MENU. Then press the SETUP button.

Table 51.

Step	Action	Procedure
5	Set barrel for BRIX	From the Setup screen, open the BRIX Setup screen, shown in Figure 54. Use the Up and Down arrows to highlight BRIX SETUP. Press the GO button at the bottom of the display.
6	Select barrel	Use the Up and Down arrows to highlight the desired barrel for BRIXing.
7	Perform BRIX procedure	Locate the appropriate barrel sample tube and hold a cup under it. Open the valve at the end of the sample tube. Press the BRIX button, and wait 3-5 seconds. The product pump pumps product for approximately 3 seconds. After the sample is dispensed Press BRIX twice more to dispense product two more times. Discard all three of these samples.
8		Press the BRIX button a fourth time. Collect this sample in a cup and close the valve at end of the sample tube.
9	Measure BRIX	Place adequate amount of the product on a refractometer and read the BRIX value. A target BRIX reading of 13.0 (+/- 1.0) is normally desired for sugar-based syrups. Lower values for some diet syrups can be specified. Check with the syrup manufacturer if you are not sure.
10	Adjust BRIX	If BRIX is not within the proper range, adjust the syrup/water mixture by opening or closing the syrup valve, shown in Figure 58., and then retest.
11	Clear hose	When BRIX measurement is complete, press the valve on the bottom of the appropriate water solenoid to flush out the hose before closing the valve at the end of the hose.
12	Set product supply valve	Turn product supply valve back to the (BARREL) position for the barrel you tested. (See Figure 57).
13	Replace access panel	Replace the hoses and the access panel. Secure the panel with the two screws removed in Step 2. This completes the procedure.

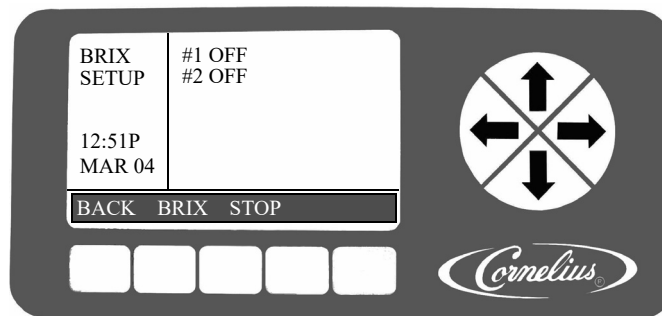

Figure 54. BRIX Setup Screen

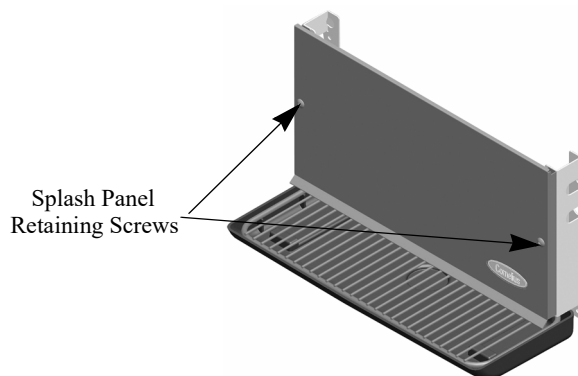

Figure 55. For Classic Splash Panel Mounting Screws

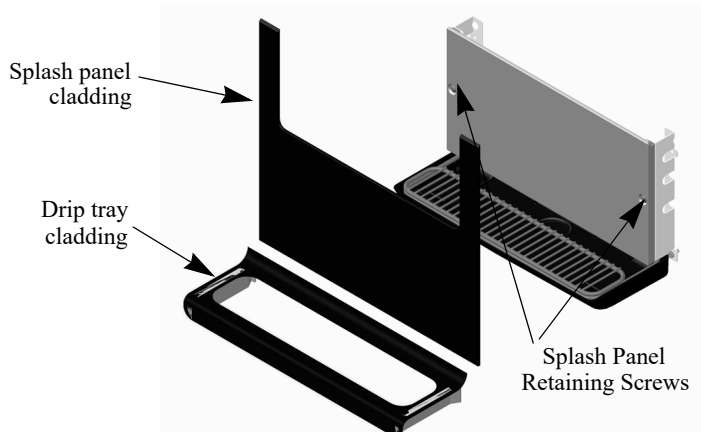

Figure 56. For Carbon Splash Panel Mounting Screws



Figure 57. Product Control Valves

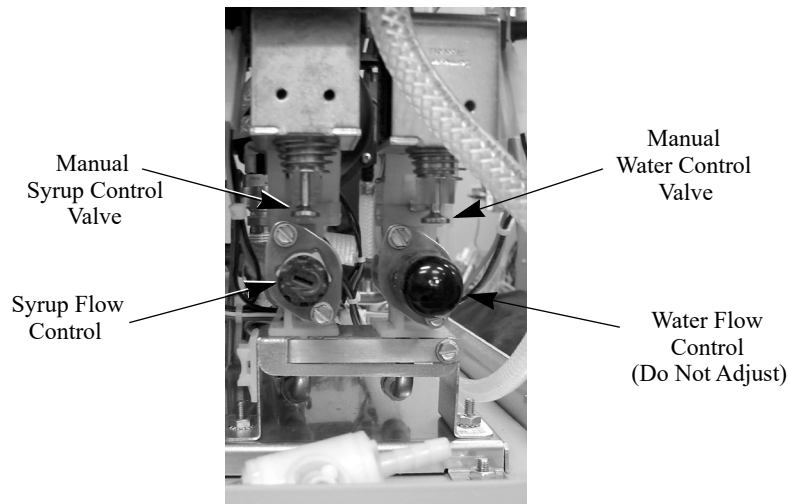

Figure 58. Flow Controls

Motor Setup Menu

Motor setup is initially done at the factory and does not need to be changed unless a barrel motor or barrel components are replaced, adjusted or removed and reinstalled.

This menu allows you to select different motor types for each barrel in the unit and run the calibration procedure on that motor. This procedure correlates the actual viscosity of the barrel and its contents with the electrical characteristics of the motor. These characteristics are stored by the control system and are accessed at the time of calibration for each particular motor.

Because of the differences between motor characteristics from different motor suppliers, the Motor setup screen, shown in Figure 59, is used to adjust the unit settings to match the motor type being installed. It provides the correct table of electrical characteristics from imbedded settings located in non-volatile memory. Perform the procedure described in Table 54 to change the motor type setting. Insure that the motor type matches the settings listed in Table 52 based on model.

NOTE: If the Motor Type shown is "DEFAULT", it indicates that the EEPROM is not installed or is faulty.

Table 52.

Model	Motor Type
All 60 Hz	1
All 50 Hz	2

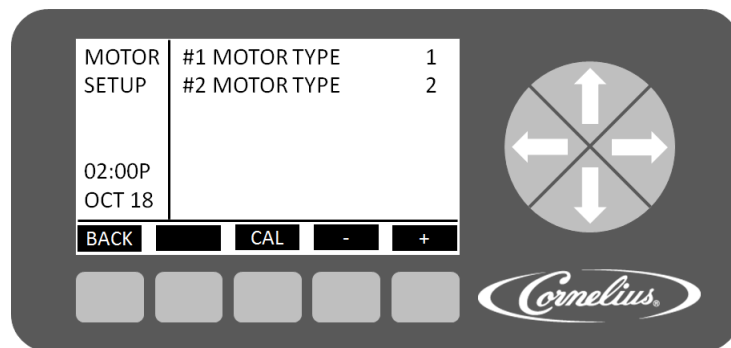

Figure 59. Motor Setup Screen

Table 53.

Button	Description
BACK	Returns the display to the Select menu
CAL	Verifies the motor settings of a new motor.
-	Decrements the highlighted field
+	Increments the highlighted field

Table 54.

Step	Action	Procedure
1	Set barrel for Motor Type	From the Maintenance menu (M), open the Motor Setup menu, shown in Figure 59.
2	Select the barrel	Use the Up and Down arrows to highlight the desired barrel
3	Select the proper motor type	Press the + or - buttons at the bottom of the display to select the proper motor type
4	Complete the procedure	Press the BACK button at the bottom of the display to save the settings and return to the Setup menu.

Calibrating a Motor

Calibration of motors is typically required when a motor or any associated barrel components (i.e., scrapper blades, seal, faceplate, etc.) is removed or replaced. Calibration establishes a new baseline for the motor assembly. This allows the system to determine proper viscosity settings for the new motor. When a new motor is installed in the unit or any of the barrel components are changed or adjusted, the motor should be calibrated by performing the procedure described in Table 55.



CAUTION:

Calibration must be performed when the product in the barrel is completely liquid. There must not be any ice on the scraper blade.

Table 55.

Step	Action	Procedure
1	Re-assemble barrel	It is VERY IMPROTANT that calibration be performed when the product in the barrel is in a 100% liquid state. There can be no ice in the barrel or on the beater bar.
2	Defrost the barrel	Select DFRST on the Barrel Status menu (Figure 39). It is very important that calibration be performed on a fully defrosted barrel (outlet temperature must be 41°F or barrel must be purged and refilled with new product).
3	Select Motor Setup	Use the Up and Down arrows to highlight MOTOR SETUP on the Maintenance menu.
4	Select the barrel	Use the Up and Down arrows to highlight the desired barrel
5	Start calibration	Press the CAL button at the bottom of the Motor Setup menu to start the calibration process. The calibration cycle continues for five (5) minutes to allow the gearbox to stabilize at temperature and ensure correct calibration. At that time the motor stops and it is calibrated.
6	Complete the procedure	Press the BACK button at the bottom of the display to return to the Maintenance menu.

System Menu

The System menu is used during production to set up the unit. It also allows the technician to view and change the number of barrels, the number of compressors and the number of pressure sensors present in the system, as shown in Figure 60. The description of these items is shown in Table 56.

NOTE: Changing these values to a number that doesn't match the physical number of items in the system generates errors or turns off some of the equipment present in the system.

When the individual fields are highlighted, the display buttons change. Refer to Table 56 for a listing of the button functions for the various field selections.

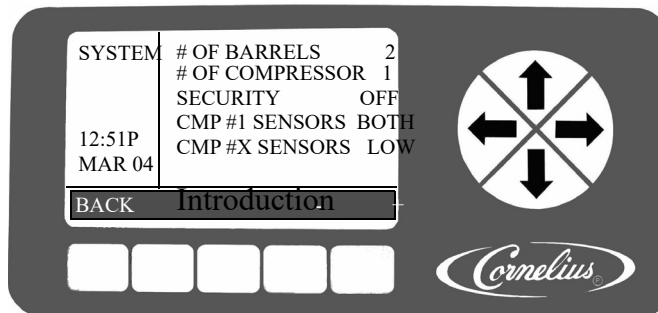

Figure 60. System Screen

Table 56.

Display	Description
# OF BARRELS	This selection shows the number of barrels in the system and allows the user to change the quantity.
# OF COMPRESSORS	This selection shows the number of compressors in the system. Currently this number is fixed at one and cannot be changed.

Table 56.

Display	Description
SECURITY	This selection allows the user to turn security on or off.
CMP #X SENSORS	This selection allows the user to choose which pressure sensors are read for the compressor.

Option	Button 2	Button 3	Button 4	Button 5
# of Barrels			-	+
# of Compressors			-	+
Security			OFF	ON
Compressor Sensors	NONE	LOW	HIGH	BOTH

Security

System security is located on the System menu. It allows a supervisor or service technician to keep unauthorized personnel from accessing the Maintenance menu. This feature is activated on the System menu. When security is turned on, users can only access the Main and Setup menus. The word LOCKED appears in the upper left corner of the display to inform users that security is enabled.

Pressing the extreme Left and Right buttons (Buttons 1 and 5) on the bottom of the display simultaneously and holding them for approximately five (5) seconds unlocks the Security menu. If security is left ON on the System menu, when the system times out or when the user goes back to the Main menu, security is re-activated and the Maintenance menu is not accessible. To disable security, access the System menu, highlight Security and press the OFF button.

Pressure Sensors

Pressure sensors allow the technician to view the high and low-side pressures in the refrigeration system without having to connect external gauges to the system. To view this information, go to the Unit Data screen shown in Figure 41 and press the UNIT button. The System screen, shown in Figure 61, is displayed.

The number and type of sensors in the unit are typically set at the factory and should not be changed. Data is only available on the sensors installed. If a sensor that is not installed in the unit is activated, incorrect data is displayed. It is possible to install sensors in the field, but it is not recommended because system refrigerant charge may be lost.

The low side pressure sensor is used to monitor compressor reversal. If it is not installed on the unit, the unit may not operate properly.

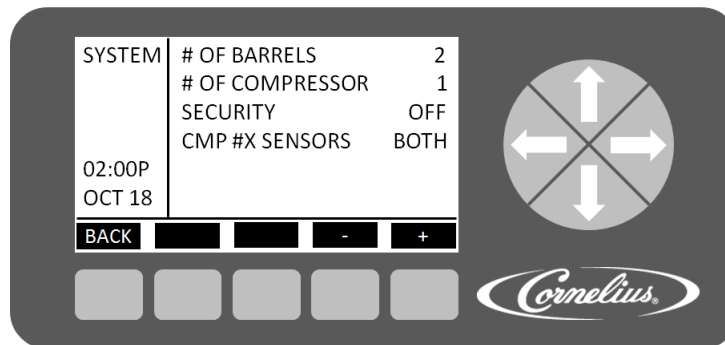

Figure 61. System Screen

When the pressure sensors selection is highlighted, pressing the NONE button removes the pressure readings from the Unit Data screen, shown in Figure 41. If LOW is selected, only the low pressure reading is displayed. If HIGH is selected, only the high pressure reading is displayed.

NOTE: If a pressure sensor is open, the pressure reading is 386 PSIG.

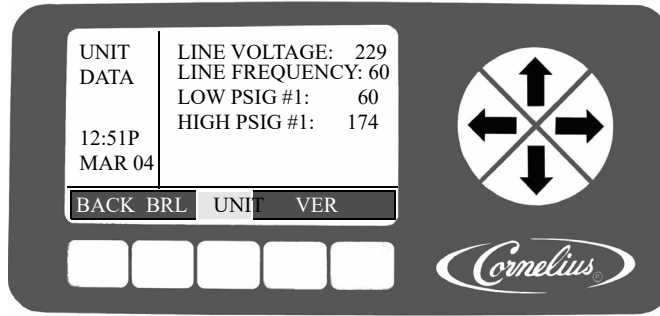

Figure 62. Unit Data Screen

OPERATION

MAINTAINING PRODUCT QUALITY

It has been determined that the following factors can affect the rate at which product quality diminishes (as indicated by a change in product appearance).

1. Dispensed Product Throughput
2. Programmed Defrost Scheduling
3. Viscosity Setting

Cornelius recommends the following instructions be read and followed relative to operating and establishing settings for the FCB equipment. Cornelius equipment service manuals contain instructions on how to program settings within the control system. Operators who have not been trained on servicing Cornelius FCB equipment should not attempt to modify equipment settings but should contact an accredited service provider.

Cornelius makes the following recommendations to help assure maximum product quality.

Dispensed Product Throughput

FCB equipment is designed to provide a high throughput of frozen carbonated product to meet peak draw demands. Where low product throughput is experienced, there is the potential for product quality to diminish. The information shown in Table 57. outlines the minimum throughput per barrel that must be dispensed on a 24 hour basis.

Table 57.

Viper	Viscosity \leq 4	Viscosity $>$ 4
Volume of dispensed product per barrel per 24 hours required to maintain product quality.	48 oz.	60 oz

NOTE: Cornelius recommends that, in conditions where the FCB machine is operational and the minimum throughput (as described in Table 57. is not met on a per barrel basis, product should be dispensed and discarded to increase throughput and help assure that product quality is maintained.

NOTE: Data in Table 57. assumes equipment has been correctly installed, commissioned and calibrated as per directions contained in all technical literature published by Cornelius and the recommendations contained in this document have been followed.

Cornelius recommends that, in conditions where the FCB machine is operational and the minimum throughput is not met on a per barrel basis, product should be dispensed and discarded to increase throughput and help assure that product quality is maintained.

Programmed Defrost Scheduling

The control system in the Viper system includes a function to automatically defrost product in the barrel at programmed intervals based on the viscosity of the product. Programmed defrosts are scheduled frequently to ensure that product quality within the barrel is maintained. Failure to defrost regularly during periods of low throughput allow increased ice crystal size, with a possible decrease in product quality. Regular throughput of dispensed product replenishes the barrel frequently with liquid and reduces the requirements for programmed defrosts. The unit automatically senses the lack of throughput and maintains the product quality by defrosting the barrels more frequently when throughput is slow.

Sleep Mode Recommendations

Cornelius recommends programming a sleep period for the machine during any amount of time over 3 hours that the unit is not used. This increases the life of the machine and reduces energy consumption.

A wake up time must be programmed after the sleep period to return the unit to normal operation. Cornelius recommends programming the wake up time for approximately 20 minutes before the product is needed. This is the time recommended

if the ambient temperature is at 75°F. The times will vary depending on the ambient temperature (a higher ambient temperature requires more time for the product to cool).

Viscosity Setting

The control system includes a function to select the desired product viscosity. This function is referred to as “Viscosity Setting”. There are selectable viscosity ranges from 1-9. The higher the number selected, the more viscous the frozen product in the barrel becomes. This increased viscosity is achieved by freezing the product in the barrel to a lower temperature thereby increasing ice crystal size/growth. As the ice crystal size increases, however, there is potential for product quality to diminish.

Cornelius recommends that the viscosity settings be set at the lowest possible setting to achieve the desired drink quality. In most typical installations using a sugar-based syrup, acceptable drink quality can be achieved by programmed viscosity settings in the range of 3-5 for Viper.

Diet FCB syrups freeze much more readily than sugar based syrups, so the viscosity setting should be selected at the minimum value available (which is 1 or 2 for the Viper).

STARTING THE UNIT

The following table, Table 11., describes the basic procedure for starting the Viper. Refer to the Operator’s Manual (P/N 620073146OPS) for details on operation of the Viper unit.

Table 58.

Step	Action	Procedure
1.	Open the merchandiser	Open the merchandiser and expose the control panel.
2.	Turn on the barrels	Turn all barrels on by pressing the buttons labeled ON to start the normal refrigeration process.
3.	Close the merchandiser.	Close the merchandiser. In approximately 20 minutes, product is ready to serve.

PREVENTATIVE MAINTENANCE

SUMMARY

There are no daily maintenance procedures required on the Viper unit other than normal cleanup of spills or overspray and emptying the drip tray. Normal equipment maintenance intervals are listed in Table 59. It is recommended that a preventative maintenance procedure be performed every twelve (12) months. This procedure should include all of the maintenance items described in Table 59 and the following sections.

Table 59

Preventative Maintenance Summary	
Maintenance Procedure	Frequency of Maintenance
Clean Air Filter	Monthly or more often, as necessary (See Table 60)
Check BRIX	Every 12 months or when changing syrup types ("BRIX Setup Menu" on page 77)
Seal Change	Every 12 months
Clean Condenser Coil	Every 12 months or as necessary
Sanitize Unit	Every 12 months or when changing syrup types
Check Water Filter	Every six months or if water pressure in the system is low.
Change or Rotate Scraper Blades	Every 12 months
Check for Leaks	Every 12 months
Clean BIB Connectors & check operation of syrup sold out switches	Every six months or when changing syrup types.
Check Clock Setting	Every six months or when changing to or from daylight savings time
Change caged o-ring on models w/ Motor-man Valves.	Lubricate every 6 months or more frequently if valve lever gets tight to operate. Caged O-Rings should be replaced every 12 months or when changing syrup types



CAUTION:

Only trained and certified electrical, plumbing and refrigeration technicians should service this unit. All wiring and plumbing must conform to national and local codes.

MONTHLY MAINTENANCE

A general inspection of the machine for leaks and cleanliness should be done on a weekly basis. Any abnormal conditions should be reported and corrected when noticed.

Cleaning Air Filter

The air filter should be cleaned at least once a month (more often in harsh environments). Perform the procedure in Table 60 to clean the air cleaner.

Table 60

Step	Action
1.	Open the merchandiser
2.	Remove the filter, shown in Figure 63, by grasping the two tabs and sliding it straight out the front of the unit.
3.	Wash the filter with clean water. Shake out the excess water.
4.	Reinstall the air filter.
5.	Close the merchandiser.



Figure 63. Air Filter Location

ANNUAL MAINTENANCE

There are several procedures that should be completed on an annual basis. These procedures help to insure proper operation of the system on a long term basis. Refer to Table 59 for a listing of the annual maintenance items.

Inspecting and Replacing Scraper Blades

Scraper blades should be inspected for wear during the annual maintenance check. To inspect the blades, perform the procedure in Table 61.

WARNING:

In Step 2, when purging is complete, disconnect electrical power from the unit. Failure to disconnect the power could result in serious injury, death, or equipment damage. .

Table 61

Step	Action
1.	“Purging a Barrel” on page 55.
2.	When purging is complete, disconnect electrical power from the unit.
3.	Remove the four (4) 3/4 in. nuts from the faceplate and slowly remove the faceplate from the unit.
4.	Slowly pull the blade assembly out of the barrel.
5.	Rinse and inspect the blade assembly for signs of wear.
6.	If there is significant wear on the blades, Reverse or replace them, depending on the wear pattern.

Table 61

Step	Action
7.	Replace the blade assembly and bushings (PN 2392) onto the motor shaft in the barrel.
8.	Re-install the faceplate and replace the four (4) mounting nuts. Hand tighten the nuts until the faceplate makes contact with the gasket, then use a wrench to tighten the nuts an additional 1/4 turn. Be careful not to over tighten the nuts or cracking of the faceplate may result.
9.	Refill the barrel with product. "Filling a Barrel" on page 67.
10.	When barrel fill is complete, perform a motor calibration. "Calibrating a Motor" on page 73.

Cleaning the Syrup Connections

Syrup connections should be cleaned at least every six months, or when syrup types are changed. Perform the procedure in Table 62 to clean the BIB connectors.

Table 62

Step	Action
1.	Open the merchandiser and select OFF for the barrel to be cleaned.
2.	Remove the quick disconnect from the BIB container.
3.	Fill a suitable pail or bucket with soap solution.
4.	Submerge the disconnect in the soap solution and then clean it using a nylon bristle brush. (Do not use a wire brush). Rinse with clean water and dry.

Servicing Motorman Dispensing Valves

NOTE: Dispensing valves with caged o-rings should be serviced (lubricated) every 6 months or more frequently if the valve lever gets tight to operate. Caged O-rings should be replaced every 12 months.

Refer to and perform the procedure in Table 63 (see step 18) to lubricate or change the caged o-rings in each dispensing valve on the unit.

Suggested Sanitizers

KAY-5® Sanitizer/Cleaner (100 PPM)

Mix one packet of KAY-5® Sanitizer/Cleaner per 2.5 gallons of tap water [70°-100°F (24°-35°C)] according to manufacturer's instructions to ensure 100 PPM of available chlorine.

Household Bleach (200 PPM)

For 6% Sodium Hypochlorite bleach, mix 2.5 fl oz (75mL) in 5 gallons of tap water [70°-100°F (24°-35°C)]. For 5.25% Sodium Hypochlorite bleach, mix 2.2 fl oz (66mL) of bleach in 5 gallons of tap water [75°-95°F (24°-35°C)]. This will ensure a bleach solution of 200 PPM of available chlorine.

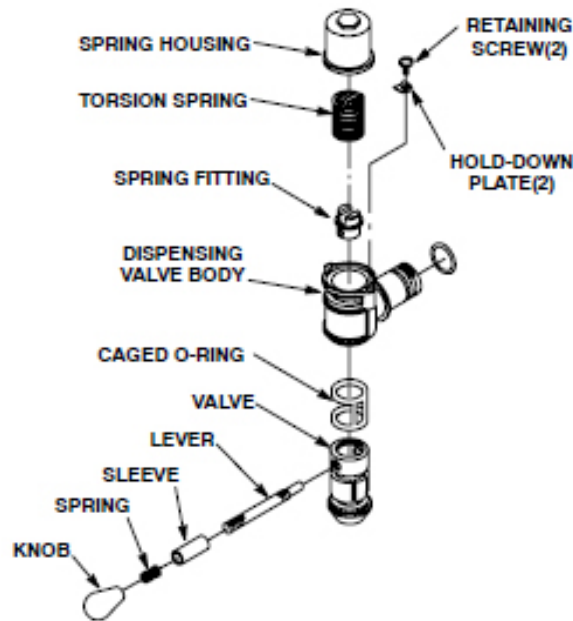

Figure 64. Self-Closing Dispensing Valve

⚠ WARNING:

In Step 1, when defrost is complete, disconnect electrical power from the unit. Failure to disconnect the power could result in serious injury, death, or equipment damage.

Table 63

Step	Action
1.	Defrost freeze cylinders, shut unit down, disconnect electrical power from Unit.
2.	Perform the procedure in Table 65 to empty the barrels.
3.	Remove the hex nuts and flat washers securing the faceplate to the freeze barrel, then remove the faceplate from the barrel.
4.	Carefully remove the large o-ring from the faceplate.
5.	Unscrew the relief valve from the faceplate.
6.	Disassemble the dispensing valve (see).
7.	Remove ice ball grate from faceplate, if applicable
8.	Remove the two screws and hold-down plates securing the spring housing to the dispensing valve body, then remove the housing.
9.	Remove the torsion spring from the dispensing valve.
10.	Remove the knob, spring, sleeve, and lever from the dispensing valve.
11.	Remove spring fitting from dispensing valve.
12.	Press the valve with the caged O-ring, down and out of the dispensing valve body.
13.	Carefully remove the caged O-ring from the valve.
14.	Wash all the parts in warm water. Remove all traces of syrup and lubricant, especially from the faceplate, o-rings, ice ball grate (if applicable), and dispensing valve. If parts are excessively coated, wipe clean with a paper towel to remove excess syrup and lubricant, especially from caged o-ring and dispensing valve. Use a brush (provided with the unit) to clean the faceplate relief valve passages.
15.	Submerge all the parts in a sanitizing solution according to the suggested sanitizers above for 10 minutes (no more than 15 min).
16.	Remove the parts from the sanitizing solution and place them on clean paper towels.

Table 63

Step	Action
17.	Assemble the dispensing valve. Rinse them with warm water, and place them on clean paper towels.
18.	Lubricate the caged o-ring. Carefully install the caged o-ring onto the valve from the straight end (opposite tapered end). Lubricate the grooves that the o-ring rides to fill in all void areas around the o-ring.
19.	Carefully install the valve with the caged o-ring in the dispensing valve body.
20.	Install the spring fitting, knob and lever parts, torsion spring and spring housing assembly by reversing the removal procedure. Do not tighten down the hold-down plates securing the spring housing at this time.
21.	After re-installing the faceplate, turn the dispensing valve spring housing to the left (counterclockwise) to put tension on the tension spring. Apply just enough tension so that the dispense valve shaft returns to the closed position after release. Do not overtighten. Overtightening results in a high activation force on the valve.

NOTE: Use Dow-Corning DC-111 (P/N 321471000) light grade silicone lubricant to lubricate the O-rings.

Servicing SPH Dispensing Valves

Sanitizing the System

The syrup systems should be sanitized every 360 days by a qualified service technician following the sanitizer manufacturer’s recommendations or when changing syrup types.

The sanitizing process consists of emptying the barrel, washing the lines and barrel, cleaning the BIB connectors, rinsing and refilling the system.

Suggested Sanitizers

KAY-5® Sanitizer/Cleaner (100 PPM)

Mix one packet of KAY-5® Sanitizer/Cleaner per 2.5 gallons of tap water [70°-100°F (24°-35°C)] according to manufacturer's instructions to ensure 100 PPM of available chlorine.

Household Bleach (200 PPM)

For 6% Sodium Hypochlorite bleach, mix 2.5 fl oz (75mL) in 5 gallons of tap water [70°-100°F (24°-35°C)]. For 5.25% Sodium Hypochlorite bleach, mix 2.2 fl oz (66mL) of bleach in 5 gallons of tap water [75°-95°F (24°-35°C)]. This will ensure a bleach solution of 200 PPM of available chlorine.

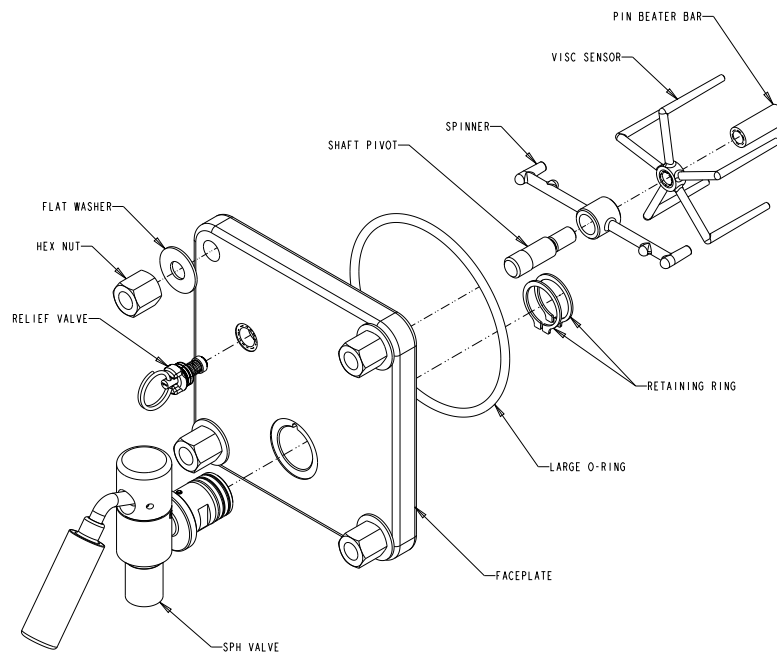

Figure 65.

WARNING:

In Step 1, when defrost is complete, disconnect electrical power from the unit. Failure to disconnect the power could result in serious injury, death, or equipment damage.

Table 64.

Step	Action
1.	Defrost freeze cylinders, shut unit down, disconnect electrical power from Unit.
2.	Perform the procedure in Table 65 to empty the barrels.
3.	Remove the hex nuts and flat washers securing the faceplate to the freeze barrel, then remove the faceplate from the barrel. 4. Carefully remove the large o-ring from the faceplate.
4.	Unscrew the relief valve from the faceplate.
5.	Disassemble the dispensing valve (see Figure 64).
6.	Remove Ice Ball Grate from faceplate (if applicable).
7.	Wash all the parts in warm water. Remove all traces of syrup and lubricant, especially from the faceplate, o-rings, ice ball grate (if applicable), and dispensing valve. If parts are excessively coated, wipe clean with a paper towel to remove excess syrup and lubricant, especially from caged o-ring and dispensing valve. Use a brush (provided with the unit) to clean the faceplate relief valve passages.
8.	Submerge all the parts in a sanitizing solution according to the suggested sanitizers above for 10 minutes (no more than 15 min).
9.	Remove the parts from the sanitizing solution, rinse them with warm water, and place them on clean paper towels.
10.	Carefully re-install the valve and corresponding parts into the faceplate, and re-install the faceplate onto the machine.

NOTE: Use Dow-Corning DC-111 (P/N 321471000) light grade silicone lubricant to lubricate the faceplate O-ring.

Emptying a Barrel

To empty the barrel, perform the procedure in Table 7

Table 65.

Step	Action
1.	From the Barrel Status menu, press the DFRST button.
2.	When the barrel is defrosted, go to the Maintenance menu. If the security feature is active, access the Maintenance menu by pressing and holding the far left and right buttons simultaneously for approximately five seconds.
3.	Remove the splash panel. "BRIX Setup Menu" Figure 54.
4.	Turn the Product/BRIX valve 90 degrees clockwise to shutoff product to the barrel.
5.	Place a large waste container under the dispense valve and drain as much product as possible from the barrel.
6.	When the pressure in the barrel drops, from the Barrel Maintenance menu, press the PURGE button to repressurize the barrel with CO ₂ . As product level lowers in the barrel, partially close the valve to avoid spurting.
7.	Disconnect the BIB from the unit.

NOTE: The unit should be sanitized every 180 days by a qualified service technician following the sanitizer manufacturer's recommendations.

Flushing the System of Syrup

After emptying the barrel, the barrel should be flushed of product before proceeding with the sanitizing procedure. Perform the procedure in Table 8.

Table 66.

Step	Action
1.	Fill a clean 5-gallon pail with plain water.
2.	Connect a sanitizing fitting (p/n cc 28688) to the BIB connector. Put the connector in the bucket of water.
3.	Make sure the Product/BRIX valve is in the BRIX position.
4.	Hold a waste container under the brix tube to collect syrup from the syrup line and open the manual syrup flow valve (see Figure 58.) to start filling the syrup line with plain water. Continue to hold the manual syrup flow valve open until clean water starts coming out of the BRIX tube.
5.	Release the manual syrup flow valve and turn the Product/BRIX valve to the Product position.
6.	Open the manual water flow valve (see Figure 58) to start filling the barrel with water. At the same time, open the faceplate relief valve until water comes out.
7.	When the barrel is full, press the SPIN button on the Barrel Status menu, while highlighting the appropriate barrel. This starts the scraper blade. Allow blade to operate for fifteen seconds.
8.	Turn barrel OFF by pressing the OFF button.
9.	Place a waste container under the barrel dispensing valve. Open the dispensing valve and dispense all wash water from the barrel. When the pressure in the barrel drops, from the Barrel Maintenance menu, press the PURGE button to re-pressurize the barrel with CO ₂ . As the wash water level lowers in the barrel, partially close the valve to avoid spurting.
10.	Perform rear barrel seal replacement. "Barrel Motor Seal Replacement" on page 87.
11.	Perform inspection and replacement of scraper blades. "Inspecting and Replacing Scraper Blades" on page 76.
12.	Perform a leak test on the barrel. "Motor Seal Leak Test" on page 86.

Sanitizing the Barrel

Sanitize the syrup system and barrel by performing the procedure shown in Table 9

Table 67.

Step	Action
1.	Use a clean 5-gallon pail filled with a sanitizing solution and water at a temperature of 90° F to 110° F (32° C to 43° C). Prepare the sanitizing solution according to the instructions in the "Suggested Sanitizers" section above.
2.	Connect a sanitizing fitting (p/n cc 28688) to the BIB connector. Put the connector in the bucket of sanitizing solution.
3.	Make sure the Product/BRIX valve is in the BRIX position.
4.	Hold waste container under the BRIX tube to collect flush water from the syrup line and open the manual syrup flow valve to start filling the syrup line with sanitizing solution. Continue to hold the syrup flow valve open until sanitizing solution starts coming out of the BRIX tube.
5.	Turn the Product/BRIX valve in the Product position.
6.	Manually override (open) the syrup flow valve to fill the barrel with sanitizing solution.
7.	Fill the barrel with sanitizing solution by opening the faceplate relief valve until sanitizing solution comes out of the relief port.
8.	Hold a 16 oz. cup under the dispense valve. Hold the dispense valve fully open until the cup is full.
9.	Use the brush provided with the unit to clean the relief port and clean the outlet of the dispense valve with sanitizing solution.
10.	From the Barrel Status menu, press the SPIN button while highlighting the appropriate barrel. This starts the scraper blade. Allow blade to operate for minimum of 10, but no more than 15 minutes. Turn the scrapper blade off by pressing the OFF button.
11.	Place a large container under the dispense valve and drain as much sanitizing solution as possible from the barrel.
12.	When the pressure in the barrel drops, from the Barrel Maintenance menu, press the PURGE button to re-pressurize the barrel with CO ₂ . As sanitizing solution level lowers in the barrel, partially close the valve to avoid spurting.

Flushing the System

Flush the wash water from the system by performing the procedure in Table 68.

⚠ CAUTION:
Flush the system thoroughly, residual sanitizing solution left in the system may create a health hazard.

Table 68.

Step	Action
1.	Turn the Product/BRIX valve to the Product position.
2.	Manually open the manual water flow valve to start filling the barrel with wash water. At the same time, open the face-plate relief valve until water comes out.
3.	From the Barrel Status menu, press the SPIN button while highlighting the appropriate barrel. This starts the scraper blade. Allow the blade to operate for fifteen seconds, then turn barrel OFF by pressing the OFF button.
4.	To drain the water from the system, turn the barrel OFF.
5.	Place a container under the barrel dispensing valve. Open the dispensing valve and dispense all rinse water from the barrel. When the pressure in the barrel drops, from the Barrel Maintenance menu, press the PURGE button to re-pressurize the barrel with CO ₂ . As the wash water level lowers in the barrel, partially close the valve to avoid spurting.
6.	Remove the sanitizing fitting (p/n cc 28688) from the BIB connector and connect a BIB containing syrup to the syrup line.
7.	Rotate the Product/BRIX valve to the BRIX position and open the valve at the end of the tube.
8.	Hold a waste container under the BRIX tube to collect the sanitizing solution from the syrup line and open the manual syrup flow valve to start filling the syrup line with syrup. Continue to hold open the syrup flow valve until syrup starts coming out of the BRIX tube.
9.	Perform a BRIX setup. "BRIX Setup Menu" Figure 54.
10.	Fill the barrel with product as described on page 66.
11.	Perform motor calibration. "Calibrating a Motor" on page 72.

Cleaning the Water Filter

The water filter screen in the rear of the unit should be removed and cleaned every six months, during the preventative maintenance procedures. To inspect and clean the filter screen, perform the procedure in Table 69.

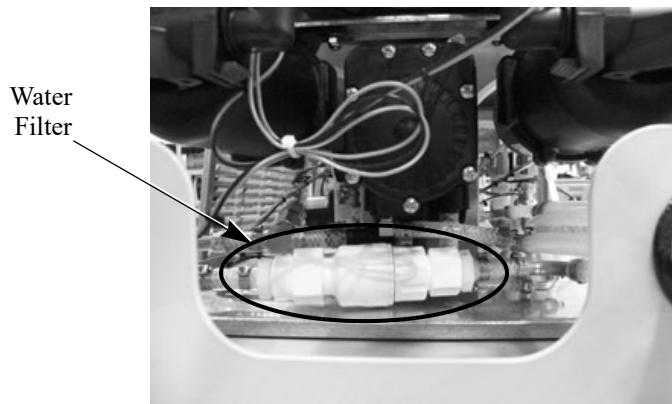

Figure 66. Water Filter Location

 WARNING:

In **Step 1**, disconnect electrical power from the unit. Failure to disconnect the power could result in serious injury, death, or equipment damage.

Table 69

Step	Procedure
1.	Disconnect power from the unit.
2.	Turn off and disconnect the water supply to the unit.
3.	Remove the rear cover of the unit.
4.	Disassemble the water filter (Use two wrenches, if necessary).
5.	Remove the filter and rinse it under running water to remove any debris.
6.	Reassemble the filter.
7.	Connect and turn on the water supply to the unit.
8.	Check the filter for any leaks.
9.	Replace the rear cover.
10.	Reconnect power to the unit.

COMPONENT REPLACEMENT

The following are procedures for servicing the major components of the Viper system.

BARREL MOTOR SEAL REPLACEMENT

The barrel motor seal is typically replaced during the annual preventative maintenance procedure. The seal location is shown in Figure 67.

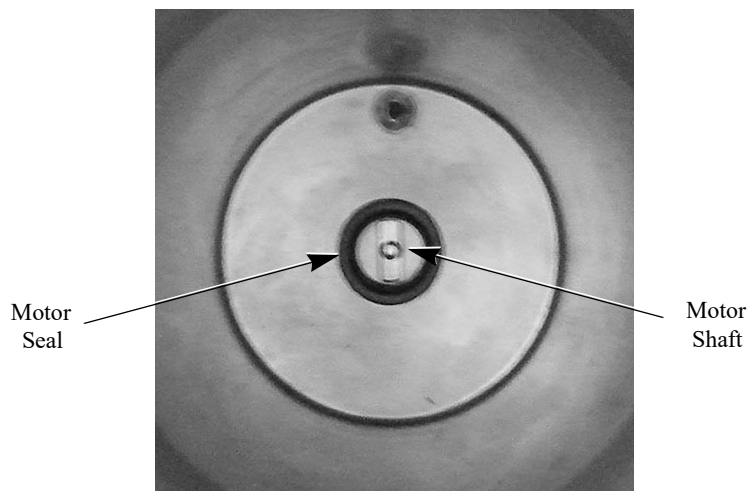

Figure 67. Front View Inside of Barrel w/ Faceplate off

Removing the Existing Seal

To remove the existing barrel seal, perform the procedure in Table 70.

WARNING:

In Step 2, when purging is complete, disconnect electrical power from the unit. Failure to disconnect the power could result in serious injury, death, or equipment damage.

Table 70

Step	Action
1.	Purge the barrel. "Purging a Barrel" on page 67
2	When purging is complete, disconnect power from the unit.
3	Open the relief valve on the front of the barrel to ensure that pressure is released. NOTE: Barrel pressure must be relieved before removing the faceplate!
4	Remove the four (4) 3/4 in. nuts from the faceplate and slowly remove the faceplate from the unit.
5	Carefully pull the blade assembly out of the barrel.
6	Remove any remaining product from the barrel.
7	Rinse and inspect the blade assembly and barrel for signs of wear (Replace if necessary).
8	Remove the seal and spacer from the rear of barrel.
9	When old seal and spacer are removed, use a clean soft cloth to clean between the motor shaft and the barrel to remove any remaining product.

Installing a New Seal

Perform the procedure in Table 71, referring to Figure 67 and Figure 68 to replace the barrel seal with a new seal.

NOTE: When installing a new seal, never use oil or silicon based lubricants. This can cause the new seal to rotate and leak!

Table 71

Step	Action
1	Remove the old seal and the spacer (see Table 61).
2	Remove the new seal from its packaging.
3	Clean the spacer.
4	Slide the spacer (with slots toward the motor housing) over the motor shaft.
5	Lubricate the inside of the seal using Dow Corning 111 Lubricant and Sealant. NOTE: Do not lubricate the static side (outer portion) of the seal. This could cause the seal to rotate in the bore and leak.
6	Carefully slide the seal over the motor shaft and press it firmly until it is fully seated against the spacer and the seal cannot be pushed any further.
7	Run your finger around the perimeter of the seal to insure it is flush against the back of the barrel.
8	Reinstall the blade assembly. Rotate the assembly while inserting it to insure that it is fully seated on the motor shaft.
9	Lubricate the faceplate o-ring.
10	Re-install the faceplate and replace the four (4) mounting nuts. Hand tighten the nuts until the faceplate makes contact with the gasket, then use a wrench to tighten the nuts an additional 1/4 turn. Be careful not to overtighten the nuts or cracking of the faceplate may result.
11	Clean the drip tray and tube using warm water.
12	Perform the seal leak test in Table 72

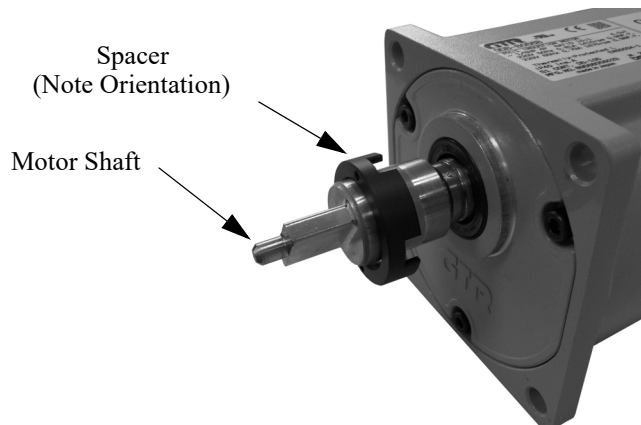

Figure 68. View of Motor Shaft with Spacer on Shaft

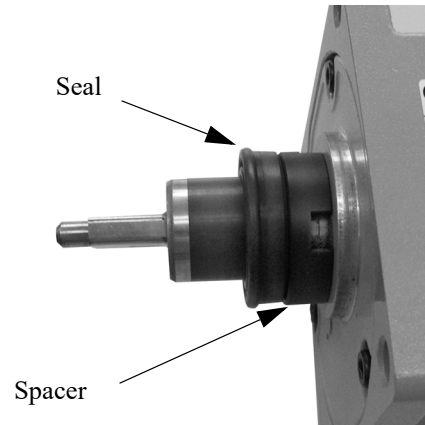

Figure 69. Side View of Seal and Spacer on Motor Shaft

Motor Seal Leak Test

After replacing the motor seal, it is advisable to test the seal under pressure before refilling the barrel with product. Perform the procedure in Table 72 to verify that the seal is installed properly and not leaking. When the seal passes the leak test, perform the motor calibration routine on 81.

Table 72.

Step	Action
1	Turn the 3-way Product Supply valve behind the splash panel to the Off (horizontal) position.
2	From the Maintenance menu, press the FILL button for the barrel. This pressurizes the barrel with CO ₂ .
3	Observe the water and syrup fill solenoids.
4	If there are NO seal leaks, these solenoids cycle off within a minute and remain off.
5	If the solenoids cycle off and remain off, the barrel seal is not leaking and the barrel is ready to be filled with product.
6	If the solenoids do not cycle off, or cycle off and on, the seal is leaking and the seal installation process described in Table 60 and Table 71 must be repeated.
7	If there are no leaks, turn the 3-way Product Supply valve to the BRIX position.

BARREL MOTOR REPLACEMENT

The barrel motor does not require any special alignment when being replaced. It mounts on four (4) bolts. These bolts are screwed into threaded bosses in the foam pack barrel assembly, as shown in Figure 70. To replace a barrel motor, perform the procedure in Table 73

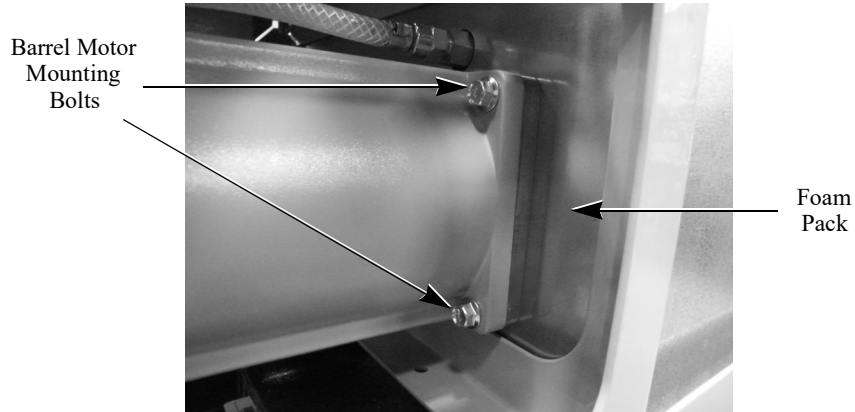

Figure 70. Side View of Motor Showing Two of the Four Mounting Bolts

Table 73.

Step	Action
1	Perform the procedure in Steps 1 through 8 of Table 73
2	Disconnect the motor from the circuit by unplugging the connector.
3	Remove the motor by removing the four (4) bolts holding the motor to the barrel assembly.
4	Install the replacement motor and connect the connector.
5	Replace the motor seal, scraper blade assembly onto the motor shaft in the barrel, as described in Table 73
6	Reconnect power to the unit.
7	Refill the barrel with product. "Filling a Barrel" on page 67.
8	When barrel fill is complete, perform a motor calibration. "Calibrating a Motor" on page 73.

MOTOR RUN CAPACITOR REPLACEMENT

The motor run capacitors, shown in Figure 71, are mounted at the rear of the unit between the barrel motors. To replace a run capacitor, perform the procedure in Table 74

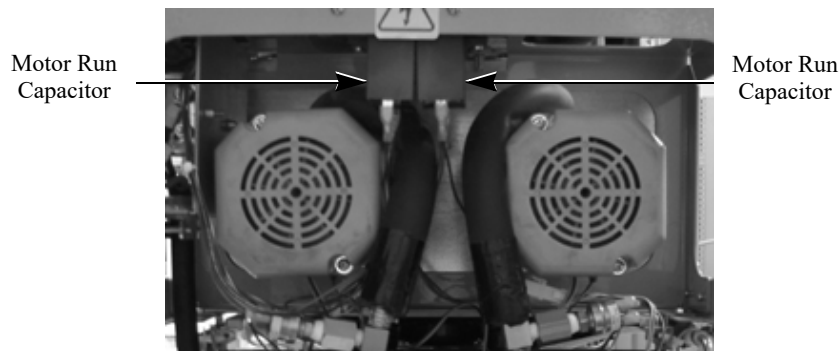

Figure 71. View of Motor Run Capacitors

⚠ WARNING:

In Step 1, disconnect electrical power from the unit. Failure to disconnect the power could result in serious injury, death, or equipment damage.

Table 74

Step	Action
1	Disconnect power from the unit.
2	Remove the rear cover.
3	Disconnect the spade clips from the defective capacitor.
4	Remove the mounting screw from the base of the capacitor.
5	Replace the capacitor.
6	Reverse the procedure to install the new capacitor.
7	Reconnect power to the unit.
8	Refill the barrel with product. "Filling a Barrel" on page 57.
9	When barrel fill is complete, perform a motor calibration. "Calibrating a Motor" on page 73.

WATER PUMP REPLACEMENT

The water pump is located just behind the water filter in the center of the unit. It is mounted on a bracket facing the rear of the unit. To replace the pump, perform the procedure in Table 75.

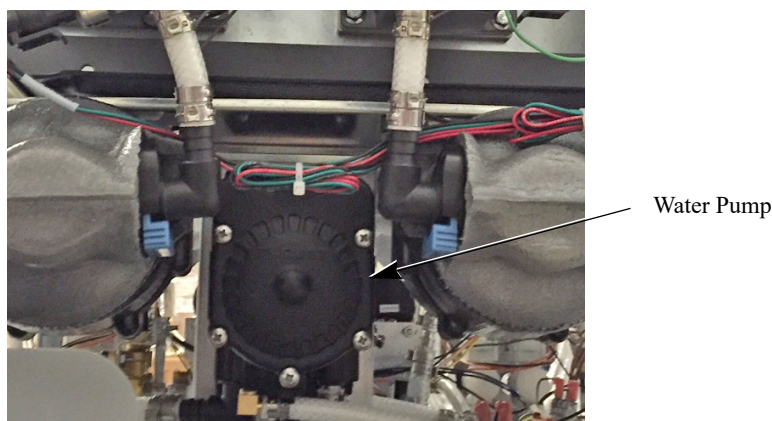

Figure 72. Rear View of Water Pump

⚠ WARNING:

In Step 1, disconnect electrical power from the unit. Failure to disconnect the power could result in serious injury, death, or equipment damage.

Table 75

Step	Action
1	Disconnect power from the unit.
2	Remove the rear cover and the side panels.
3	Disconnect the CO2 supply from the unit.
4	Remove and drain the water supply from the unit.
5	Disconnect the quick disconnect input and output water lines from the bottom of the pump.
6	Disconnect quick disconnect CO2 input from the bottom of the pump.
7	Remove the four (4) screws and locknuts holding the pump to the mounting bracket.
8	Replace the pump.

Table 75

Step	Action
9	Reverse the procedure to install the new pump.

CO₂ SHUTOFF SOLENOID REPLACEMENT

The CO₂ shutoff valves and solenoids, shown in Figure 73, are located near the center of the unit and are mounted on a bracket to the bottom of the chassis. They control the injection of CO₂ with the syrup/water combination to provide the final mixture for the product. There are one of these solenoids for each barrel in the system. When working in this area, care should be taken not to damage or misalign the CO₂ metering orifice. To replace one of these solenoids, perform the procedure in Table 76.

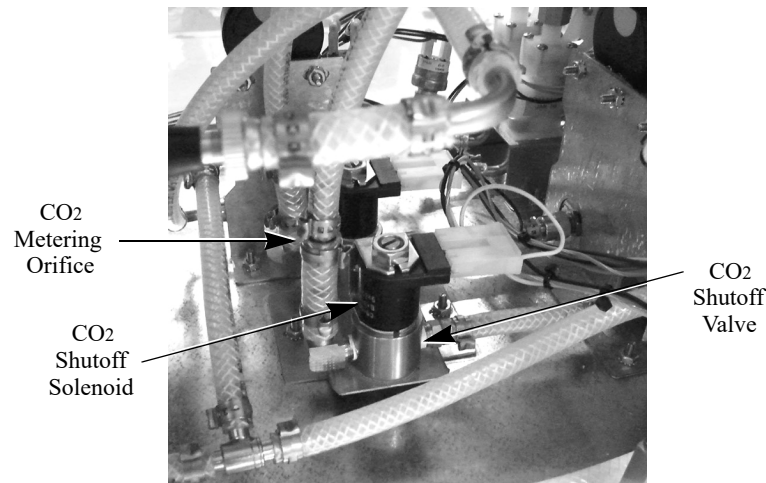
 Figure 73. Side View of CO₂ Shutoff Solenoid (2 Barrel Unit)

WARNING:

In Step 1, disconnect electrical power from the unit. Failure to disconnect the power could result in serious injury, death, or equipment damage.

Table 76

Step	Action
1	Disconnect power from the unit.
2	Disconnect the CO ₂ supply from the unit.
3	Remove the rear cover and side panels.
4	Carefully remove the tubing from the right-angle fitting at the rear of the valve. Be sure not to damage the CO ₂ metering orifice located above the fitting (Figure 73).
5	Remove the tubing from the front of the valve.
6	Remove the two (2) locknuts mounting the valve and solenoid to the base.
7	Remove the two (2) mounting screws from the bottom of the mounting bracket.
8	Replace the valve and solenoid.
9	Reverse the procedure to reinstall the valve and solenoid into the unit.
10	Test the unit for CO ₂ leaks.
11	Replace the rear and side panels.
12	Reconnect power to the unit.

Syrup and Water Shutoff Solenoid Replacement

The syrup and water shutoff valves and solenoids are mounted on a single bracket, as shown in Figure 74. Perform the procedure in Table 77 to replace the valves.

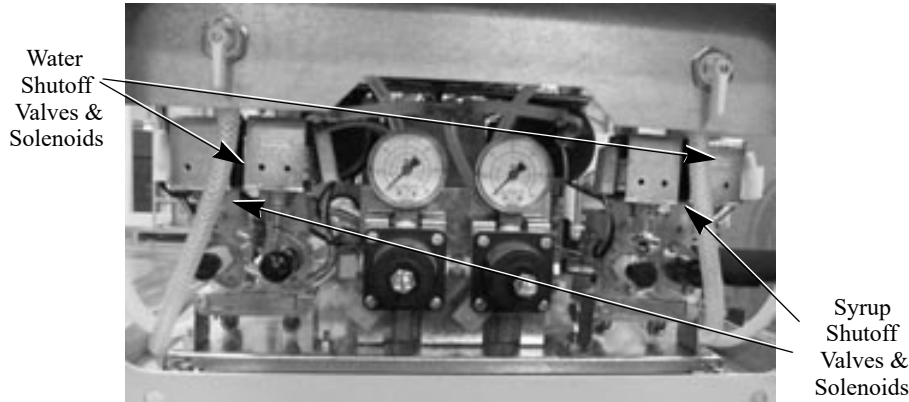
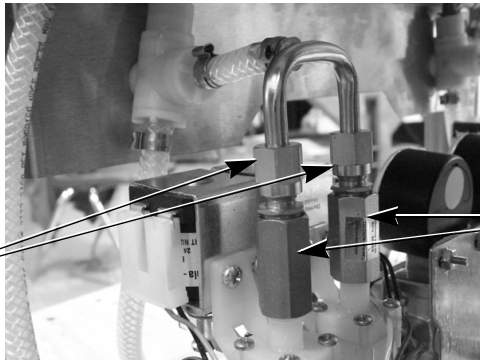

Figure 74. View of Shutoff Solenoids w/ Access Panel Removed (2 Barrel Unit)

WARNING:

In Step 1, disconnect electrical power from the unit. Failure to disconnect the power could result in serious injury, death, or equipment damage.

Table 77

Step	Procedure
1	Disconnect power from the unit.
2	Disconnect and bleed the water and syrup lines to remove pressure from the system.
3	Remove the rear cover and side panels.
4	Remove the water and syrup lines from the input to the valves.
5	Remove the Wye tube from the output (top) of the valves by loosening the nuts between the Wye and the check valves. 
6	Remove the two (2) locknuts from the base of the assembly and remove it from the unit.
7	Remove the check valve from the valve being replaced.
8	Install the check valve on the new valve and solenoid.
9	Remove the valve and solenoid from the mounting bracket and replace it.
10	Reverse the procedure to reinstall the bracket into the unit.
11	Reconnect power to the unit and test the system.

CO2 REGULATOR REPLACEMENT

The CO2 regulators are located at the center of the unit in back of the access panel, as shown in Figure 75. To replace the regulators, perform the procedure in Table 78.

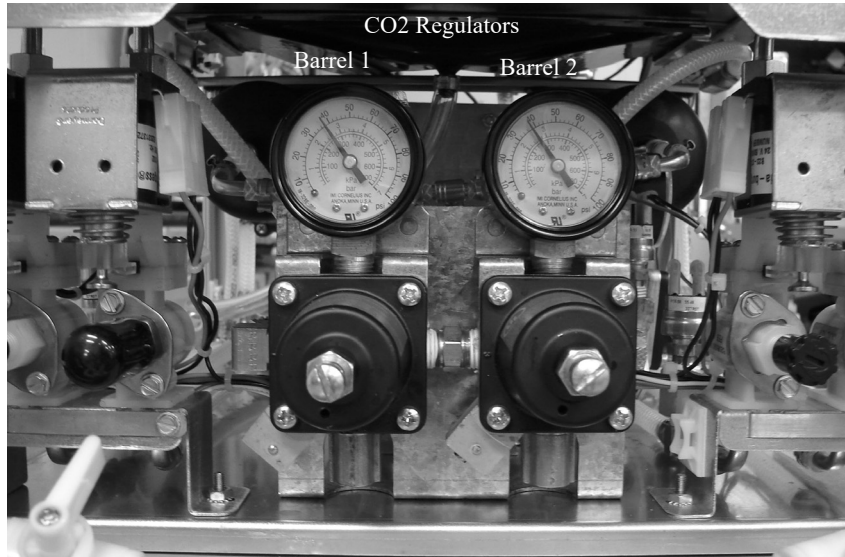

Figure 75. Front view of CO2 Regulators w/ Access Panel Removed (2 Barrel Unit)

WARNING:

In **Step 1**, disconnect electrical power from the unit. Failure to disconnect the power could result in serious injury, death, or equipment damage.

Table 78.

Step	Action
1	Disconnect power from the unit.
2	Remove the access panel (two (2) screws) and the right side panel.
3	Turn off the CO2 source and then turn the Product valve 90 degrees to the off position.
4	Relieve pressure in the barrel by opening the relief valve on the faceplate of both barrels.
5	Disconnect the three (3) supply lines at the rear of the regulators using a small wrench.
6	Remove the two lock nuts from the mounting bracket in back of the regulators.
7	Remove the pressure switch wires from the regulators.
8	Remove the assembly and replace the defective regulator.
9	Reverse the procedure to install the regulator assembly.
10	Check the system for leaks after repressurizing the system.
11	Reset the regulator to the desired setting.

CONDENSER FAN MOTOR REPLACEMENT

The fan motor is located on the top of the unit, as shown in Figure 76. If the motor needs replacement, perform the procedure in Table 79 to remove and reinstall a motor.

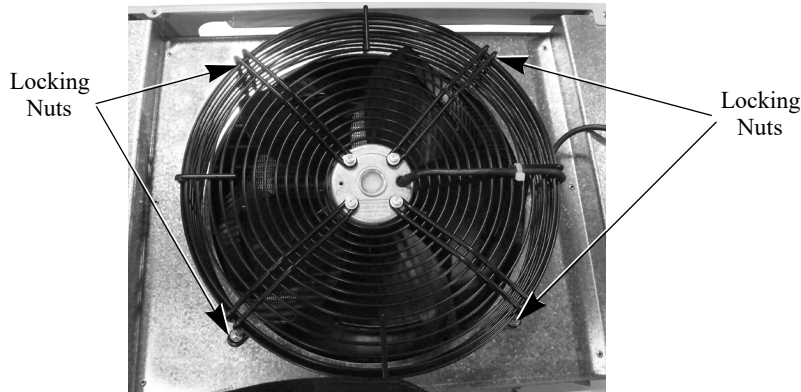

Figure 76. Condenser Fan Mounting Nuts

WARNING:

In **Step 1**, disconnect electrical power from the unit. Failure to disconnect the power could result in serious injury, death, or equipment damage.

Table 79.

Step	Action
1	Disconnect electrical power from the unit.
2	Disconnect the fan by unplugging the connector.
3	Remove the four locking nuts securing the fan to the top of the condenser.
4	Lift the fan and shroud off the unit.
5	Remove the four screws and washers securing the fan to the shroud.
6	Replace the fan.
7	Reverse the procedure to install the new fan.
8	Reconnect power to the unit.

COMPRESSOR REPLACEMENT

Caution should be used when working with refrigerants. To replace a compressor, perform the procedure in Table 80.

Be sure to reclaim refrigerant when replacing compressor.

WARNING:

In **Step 1**, disconnect electrical power from the unit. Failure to disconnect the power could result in serious injury, death, or equipment damage.

Table 80.

Step	Action
1	Disconnect power to the unit.
2	Remove the rear cover and side panels.
3	Label and disconnect all wires from the compressor.
4	Remove the four (4) mounting nuts from the base of the compressor.
5	Remove all insulation from around fittings.
6	Unsweet the suction line from the compressor.

Table 80.

Step	Action
7	Cut the discharge line on top of the compressor (Make sure line can be spliced back together.)
8	Remove the compressor and Unsweat the discharge line.
9	Reverse the procedure to install the new compressor.
10	Replace the dryer.
11	Evacuate the system and recharge it according to the Cornelius nameplate on the unit.
12	Replace the side panels and rear cover.
13	Reconnect power to the unit and test the unit.

HOT GAS SOLENOID REPLACEMENT

The hot gas valves and solenoids, shown in Figure 77, are located near the center of the unit on the right and left sides. Whenever a hot gas valve and solenoid is replaced, the dryer should be replaced at the same time.

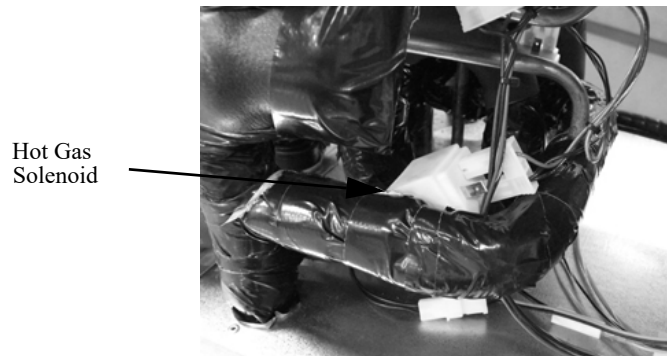

Figure 77. Hot Gas Solenoid (1 per barrel)

WARNING:

In Step 1, disconnect electrical power from the unit. Failure to disconnect the power could result in serious injury, death, or equipment damage.

Table 81.

Step	Action
1	Disconnect power from the unit.
2	Remove the side panels.
3	Reclaim refrigerant from the system.
4	Carefully remove the insulation and remove the hot gas valve and solenoid.
5	Replace the hot gas valve and solenoid.
6	Replace the insulation around the valve and solenoid.
7	Replace the filter-dryer.
8	Evacuate the system.
9	Restore the proper refrigerant charge to the system and verify proper system operation.

LIQUID LINE SOLENOID REPLACEMENT

The liquid line valves and solenoids, shown in Figure 78, are located near the center of the unit on the right and left sides. Whenever a liquid line valve and solenoid is replaced, the dryer should be replaced at the same time.

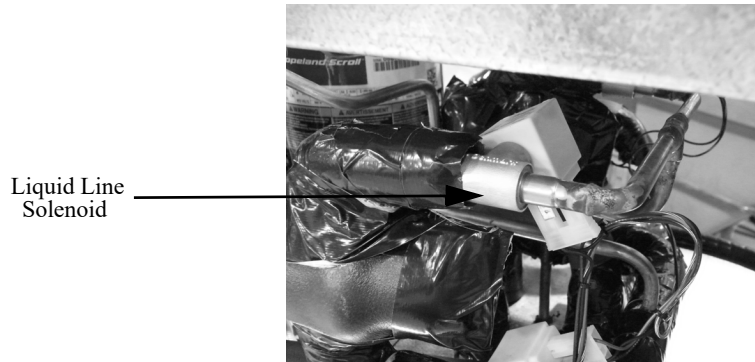

Figure 78. Liquid Line Solenoid (1 per barrel)

WARNING:

In Step 1, disconnect electrical power from the unit. Failure to disconnect the power could result in serious injury, death, or equipment damage..

Table 82

Step	Action
1	Disconnect power from the unit.
2	Remove the side panels.
3	Reclaim refrigerant from the system.
4	Carefully unwrap the foam insulation from around the valve and solenoid.
5	Remove the liquid line valve and solenoid.
6	Replace the liquid line valve and solenoid and insulation.
7	Replace the filter-dryer.
8	Evacuate the system.
9	Restore the proper refrigerant charge to the system and verify proper system operation.

SYRUP PRESSURE SWITCH REPLACEMENT

The syrup pressure switches (Sold Out Indicators) are located along the left and right sides of the unit near the front. There is one switch for each barrel in the system. Figure 79 shows the syrup pressure switch on the left side of the unit. To replace the syrup pressure switch, perform the procedure in Table 83.

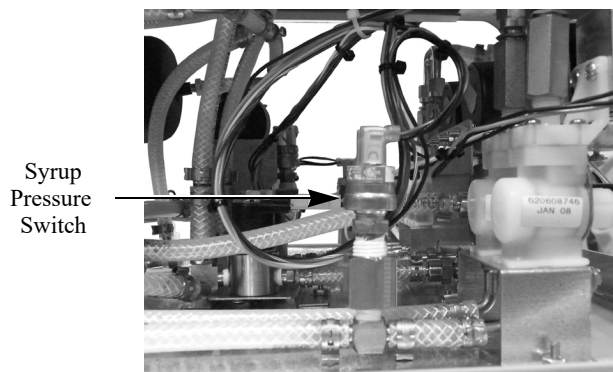

Figure 79. View of Syrup Pressure Switch and Valve

⚠ WARNING:

In Step 1, disconnect electrical power from the unit. Failure to disconnect the power could result in serious injury, death, or equipment damage.

Table 83.

Step	Action
1	Disconnect power to the unit
2	Remove the appropriate side panel.
3	Turn off the syrup supply to the unit.
4	Drain the syrup from the system.
5	Disconnect the wires on the pressure switch.
6	Remove the switch, using two wrenches.
7	Replace the switch with a new unit.
8	Reverse the procedure to install the new switch.
9	Restore the syrup supply and check for leaks.
10	Check switch operation.

WATER PRESSURE SWITCH REPLACEMENT

The water pressure switch, shown in Figure 80, is located in back of the water filter, when viewed from the rear of the unit. Access to the switch is obtained by removing the left side panel of the unit, when viewed from the rear. To replace the water pressure switch, perform the procedure in Table 84.



Figure 80. View of Water Pressure Switch

⚠ WARNING:

In Step 1, disconnect electrical power from the unit. Failure to disconnect the power could result in serious injury, death, or equipment damage.

Table 84.

Step	Action
1	Disconnect power from the unit.
2	Remove the side panel from the unit.
3	Turn off the water supply to the unit.
4	Drain the water from the system.
5	Disconnect the wires from the switch.
6	Remove the switch, using two wrenches.
7	Replace the switch with a new unit.

Table 84.

Step	Action
8	Reverse the procedure to install the new switch.
9	Restore the water supply and check for leaks.
10	Check to ensure that the new switch is working properly.

DISPLAY BOARD REPLACEMENT

When replacing or testing electronic components, be sure to wear a static strap that is connected to a chassis ground. This protects the electronic components from any static charge while working on the unit.

The display board is located on the back of the control panel display. It is mounted to the panel with four (4) Phillips head screws, shown in Figure 81.

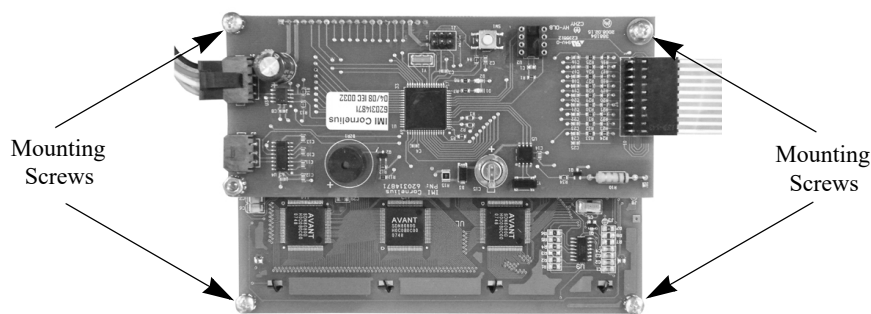

Figure 81. View of Display Board

WARNING:

In Step 1, disconnect electrical power from the unit. Failure to disconnect the power could result in serious injury, death, or equipment damage.

Table 85.

Step	Action
1	Disconnect power from the unit.
2	Connect a static strap to your wrist and any convenient chassis ground on the unit.
3	Unplug the two (2) connectors from the display board.
4	Remove the four (4) screws from the corners of the board.
5	Replace the board with a new board.
6	Reverse the procedure to install the new board.

CONTROL BOARD REPLACEMENT

When replacing or testing electronic components, be sure to wear a static strap that is connected to a chassis ground. This protects the electronic components from any static charge while working on the unit.

The control board is located in the E-Box. It is mounted to the panel on four (4) plastic mounting studs, shown in Figure 82.

⚠ WARNING:

In Step 1 in Table 86, disconnect electrical power from the unit. Failure to disconnect the power could result in serious injury, death, or equipment damage.

Table 86.

Step	Action
1	Disconnect power from the unit.
2	Connect a static strap to your wrist and any convenient chassis ground on the unit.
3	Unplug the eight (8) connectors from the control board.
4	Squeeze each of the mounting studs at the corners of the board while carefully lifting the board.
5	Replace the board with a new board.
6	Reverse the procedure to install the new board.

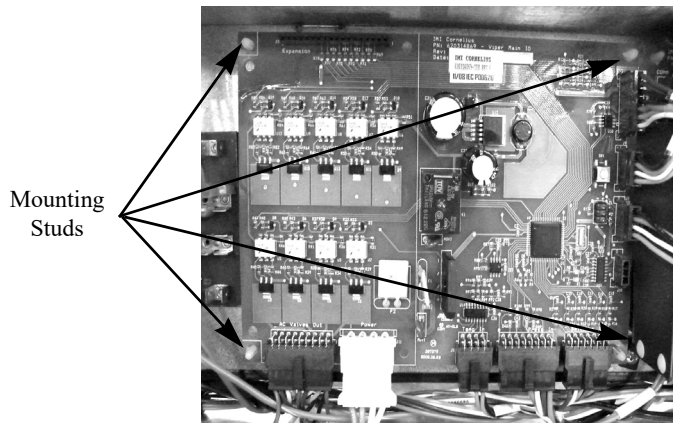

Figure 82. View of Control Board in E-Box

Backward/Forward Compatibility with Older Software Versions

With version 3.0 software release several of the boards used to control the equipment will not be backward compatible with boards containing version 2.x of the software. Please refer to the table below for compatibility.

Table 87.

Software Revision / Board Description	V2.x Part Number	V3.x Part Number	Backward Compatibility
User Interface - UI	620314871S	620314871-100S	No
Input/Output - IO	620314869S	620314869-100S	No
Motor Control	620314868S	620314868S	Yes
Status	620314874S	620314874S	Yes
Language Chips	629096930XX	629096931XX	No

The user interface (UI) board and the input/output (I/O) board must have same software version for correct operation. If the UI board and the IO board do not have the same software versions an error will be displayed on the UI. The error displayed will depend upon which board has 2.x software and has 3.x. Either “X BRL TEMP OUT” will be displayed or “H2O OUT” will be displayed followed 30 seconds later with “X BRL TEMP OUT”. If either of these messages is displayed after changing a control board check the software version. The current software version for each board can be found through the menu screen. Select, MENU, UNIT DATA, then press the “VER” key. The control boards will also have a label marked with the part number. A -100 suffix has been added to the part numbers for each of these boards to indicate version 3.0 software release.

The foreign language chips are software version dependent. Part numbers for software version 3.0 chips have the base number of 629096931 followed by an alpha suffix designating the language type. The motor control boards and the main status board will still operate with either version 2.x or 3.x software of UI and IO board. When ordering replacement/service parts for any unit check the software version of the UI and IO boards and be sure to order the correct board as listed in Table 87.

MOTOR BOARD REPLACEMENT

When replacing or testing electronic components, be sure to wear a static strap that is connected to a chassis ground. This protects the electronic components from any static charge while working on the unit.

The motor board is located in the E-Box, to the right of the control board. It is mounted to the panel on three (3) plastic mounting studs and a threaded standoff, shown in Figure 83.

WARNING:

In Step 1, disconnect electrical power from the unit. Failure to disconnect the power could result in serious injury, death, or equipment damage.

Table 88

Step	Action
1	Disconnect power from the unit.
2	Connect a static strap to your wrist and any convenient chassis ground on the unit.
3	Unplug the eight (8) connectors from the control board.
4	Squeeze each of the mounting studs at the corners of the board while carefully lifting the board.
5	Replace the board with a new board.
6	Reverse the procedure to install the new board.

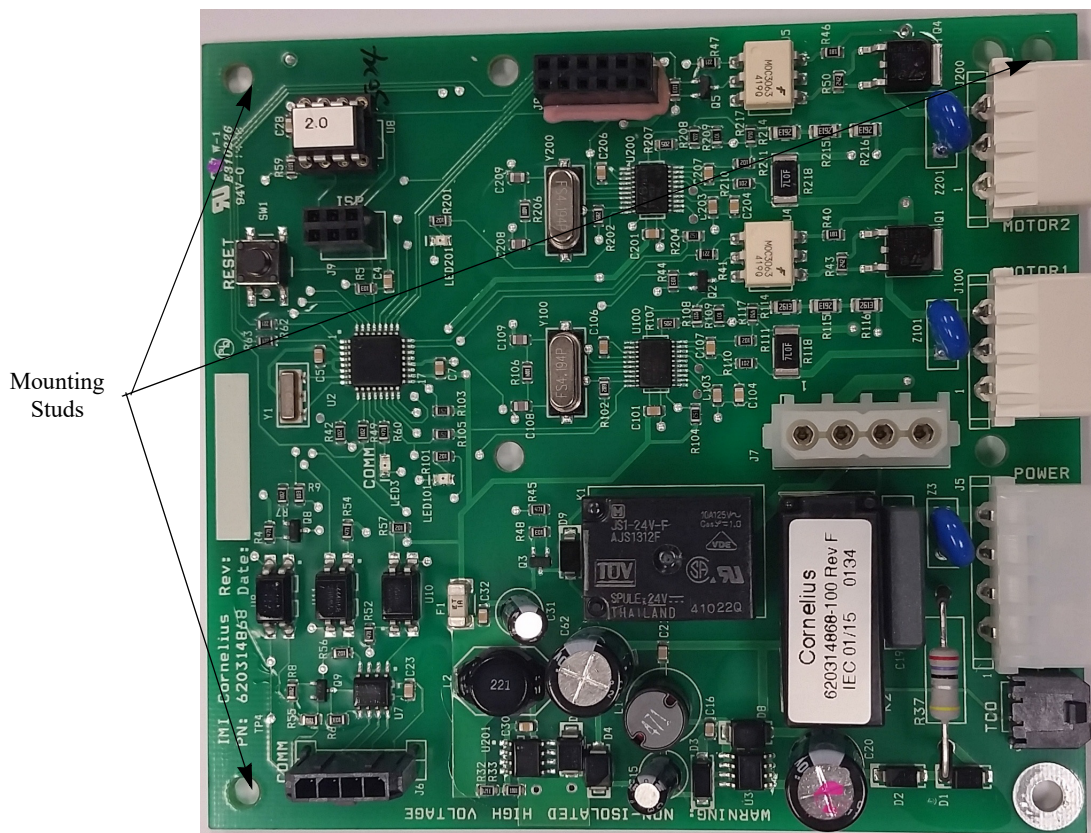

Figure 83. View of Motor Board in E-Box

TROUBLESHOOTING

TROUBLESHOOTING THE SYSTEM

Table 56.

Problem	Probable Cause	Remedy
Unit will not run.	A. Unit not plugged in. B. Circuit breaker. C. No power at L1 or L2 on contactor. D. Low voltage at T1 or T2.	A. Plug in unit. B. Reset/replace circuit breaker C. Check voltage at outlet. Check wiring to contactor. D. Replace the contactor.
“Sleep” display on barrel status menu.	A. Sleep time set. B. Clock incorrectly set. C. No wake time set.	A. Check sleep programming. B. Check sleep programming. C. Check sleep programming.
Barrel status OFF.	A. Not activated. B. Error has shut off motors. C. Unit in Diagnostics. D. Defective touch switch.	A. Turn to ON, DFRST or SPIN. B. Correct error & turn to ON, DFRST or SPIN. C. Exit diagnostics & turn to ON, DFRST or SPIN. D. Replace.
Low/High voltage ERROR.	A. Line Voltage out of SPEC (spec is 205-255 VAC for 60 Hz and 196-265 VAC for 50 Hz). B. Error range 180/260.	A. 1 - Check line voltage. 2 - Check T1/T2 with Compressor running. B. Correct line voltage.
Frozen Barrel	A. Low Brix B. Broken beater bar C. Broken drive coupler. D. No defrost. E. Are defrosts programmed all days?	A. Correct cause and reset Brix. B. Replace beater bar. C. Replace the drive coupler. D. Program defrosts in unit. E. Reprogram to all days.

TROUBLESHOOTING PRODUCT NOT COLD

Table 57.

Problem	Probable Cause	Remedy
Compressor not Running	A. Barrel not in ON mode. B. No voltage to compressor. C. Bad start components. D. Compressor’s thermal overload protector “open”. E. Open or shorted compressor windings. F. Bad control board.	A. Turn barrel to ON. B. Check power at contactor L1, L2 - T1, T2. C. Check components and wiring. D. Check resistance of compressor windings and check incoming line voltage. E. Check resistance of compressor windings. F. Troubleshoot, replace if necessary.
Compressor Running but not Cooling	A. Low refrigerant. B. Restricted condenser/filter. C. Condenser fan motor/blade defective. D. Hot gas valve leaking or open. E. Defective compressor.	A. Repair leak and weigh in new charge. B. Clean or repair. C. Repair or replace. D. Replace. E. Repair or replace.

Table 57.

Restricted Air Flow	A. Dirty filter. B. Dirty condenser. C. Damaged fins. D. Not enough “clearance” around unit.	A. Clean filter. B. Clean condenser. C. Repair/replace if necessary. D. Ensure proper spacing around unit.
Fan Motor	A. Bad connection B. Bad motor C. Cracked or bent fan blade	A. Check/connect B. Replace motor C. Replace fan blade
Hot Gas Valve	A. Miswired. B. Defective coil. C. Defective product delivery board.	A. Correct wiring. B. Replace coil. C. Replace.
No/Low Refrigerant	A. Leak.	A. Repair and weigh in new charge.
Sensors	A. Bad connection. B. Bad sensor. C. Sensor out of position. D. Defective product delivery board.	A. Correct wiring. B. Replace sensor. C. Reposition sensor and clip. D. Replace.

VIPER E 2 FLAVOR, R-454C DECOMMISSIONING PROCEDURES

DECOMMISSIONING PROCESS

Before carrying out this procedure, it is essential that the technician is completely familiar with the equipment and all its detail. It is recommended good practice that all refrigerants are recovered safely. Prior to the task being carried out, an oil and refrigerant sample shall be taken in case analysis is required prior to re-use of recovered refrigerant.

It is essential that electrical power is available before the procedure is commenced.

Decommissioning Procedure

- 1) Become familiar with the equipment and its operation.
- 2) Isolate the system electrically by disconnecting all AC power sources.
- 3) Before beginning the procedure, ensure that:
 - Mechanical handling equipment is available, if required, for handling refrigerant cylinders;
 - All personal protective equipment is available and being used correctly;
 - The recovery process is supervised at all times by a competent person;
 - Recovery equipment and cylinders conform to the appropriate standards.
- 4) Pump down the refrigerant system, if possible. NOTE: If a vacuum is not possible, make a manifold so that refrigerant can be removed from various parts of the system.

CAUTION:

**Do not overfill cylinders (no more than 80% volume liquid charge).
Do not exceed the maximum working pressure of the cylinder, even temporarily.**

CAUTION:

When the cylinders have been filled correctly and the process completed, make sure that the cylinders and the equipment are removed from site promptly and all isolation valves on the equipment are closed off.

CAUTION:

Recovered refrigerant shall not be charged into another REFRIGERATING SYSTEM unless it has been cleaned and checked.

CAUTION:

DO NOT switch recovery system on/off near the source of flammable refrigerant that may be leaking out or may leak out during recovery-system line connection/disconnection.

Recovery Requirements and Guidelines

When removing refrigerant from a system, either for servicing or decommissioning, it is recommended good practice that all refrigerants are removed safely.

When transferring refrigerant into cylinders, ensure that only appropriate refrigerant recovery cylinders are employed. Ensure that the correct number of cylinders for holding the total system charge is available. All cylinders to be used are designated for the recovered refrigerant and labeled for that refrigerant (i.e. special cylinders for the recovery of refrigerant). Cylinders shall be complete with pressure-relief valve and associated shut-off valves in good working order. Empty recovery cylinders are evacuated and, if possible, cooled before recovery occurs.

The recovery equipment shall be in good working order with a set of instructions concerning the equipment that is at hand and shall be suitable for the recovery of all appropriate refrigerants including, when applicable, FLAMMABLE REFRIGERANTS. In addition, a set of calibrated weighing scales shall be available and in good working order. Hoses shall be complete with leak-free disconnect couplings and in good condition. Before using the recovery machine, check that it is in satisfactory working order, has been properly maintained and that any associated electrical components are sealed to prevent ignition in the event of a refrigerant release. Consult manufacturer if in doubt.

The recovered refrigerant shall be returned to the refrigerant supplier in the correct recovery cylinder, and the relevant waste transfer note arranged. Do not mix refrigerants in recovery units and especially not in cylinders.

If compressors or compressor oils are to be removed, ensure that they have been evacuated to an acceptable level to make certain that FLAMMABLE REFRIGERANT does not remain within the lubricant. The evacuation process shall be carried out prior to returning the compressor to the suppliers. Only electric heating to the compressor body shall be employed to accelerate this process. When oil is drained from a system, it shall be carried out safely.

Competence of service personnel Information of procedures additional to usual information for refrigerating appliance installation, repair, maintenance and decommission procedures is required when an appliance with FLAMMABLE REFRIGERANTS is affected. The training of these procedures is carried out by national training organizations or manufacturers that are accredited to teach the relevant national competency standards that may be set in legislation. The achieved competence should be documented by a certificate.

5) Label the equipment as indicated below:

Labeling

Equipment shall be labeled stating that it has been de-commissioned and emptied of refrigerant. The label shall be dated and signed. For appliances containing FLAMMABLE REFRIGERANTS, ensure that there are labels on the equipment stating the equipment contains FLAMMABLE REFRIGERANT.

Decommissioning

If safety is affected when the equipment is taken out of service, the REFRIGERANT CHARGE shall be removed before decommissioning.

Ensure sufficient ventilation at the equipment location.

Be aware that malfunction of the equipment may be caused by refrigerant loss and a refrigerant leak is possible.

Discharge capacitors in a way that won't cause any spark; using a Supco CapDis tool.

Remove the refrigerant. If recovery is not required by national regulations, drain the refrigerant to the outside. Take care that the drained refrigerant will not cause any danger. In doubt, one person should guard the outlet. Take special care that drained refrigerant will not float back into the building.

When FLAMMABLE REFRIGERANTS are used:

- A) Evacuate the refrigerant circuit.
- B) Purge the refrigerant circuit with oxygen-free nitrogen for 5 min.
- C) Evacuate again.
- D) Fill with nitrogen up to atmospheric pressure.
- E) Put a label on the equipment that the refrigerant is removed.

Information On Correct Working Procedures

Commissioning

Ensure that floor area is sufficient for REFRIGERANT CHARGE or that the ventilation duct is assembled in a correct manner.

Connect pipes and carry out a leak test before charging with refrigerant.

Check safety equipment before putting into service.

Maintenance

Portable equipment shall be repaired outside or in a workshop specially equipped for servicing units with FLAMMABLE REFRIGERANTS.

Ensure sufficient ventilation at repair place.

Be aware that malfunction of the equipment may be caused by refrigerant loss and a refrigerant leak is possible.

Discharge capacitors in a way that won't cause any spark, using a Supco CapDis tool. (The standard procedure to short circuit the capacitor terminals usually creates sparks.)

Reassemble sealed enclosures accurately. If seals are worn, replace them.

Check safety equipment before putting into service.

WARNING:

Disconnect electrical power from the unit. Failure to disconnect the power could result in serious injury, death, or equipment damage.

Repair

Portable equipment shall be repaired outside or in a workshop specially equipped for servicing units with FLAMMABLE REFRIGERANTS.

Ensure sufficient ventilation at the repair place.

Be aware that malfunction of the equipment may be caused by refrigerant loss and a refrigerant leak is possible.

Discharge capacitors in a way that won't cause any spark, using a Supco CapDis tool.

When BRAZING is required, the following procedures shall be carried out in the order indicated:

- A) Remove the refrigerant. If the recovery is not required by national regulations, drain the refrigerant to the outside. Take care that the drained refrigerant will not cause any danger. In doubt, one person should guard the outlet. Take special care that drained refrigerant will not float back into the building.
- B) Evacuate the refrigerant circuit.
- C) Purge the refrigerant circuit with oxygen-free nitrogen for 5 min. (not required for A2L refrigerants)
- D) Evacuate again (not required for A2L REFRIGERANTS).
- E) Remove parts to be replaced by cutting, not by flame.
- F) Purge the braze point with nitrogen during the brazing procedure at the pressure indicated below.
- G) Carry out a leak test before charging with refrigerant at the pressure indicated below.

WARNING:

Disconnect electrical power from the unit. Failure to disconnect the power could result in serious injury, death, or equipment damage.

NOTES:

Reassemble sealed enclosures accurately. If seals are worn, replace them.

Check safety equipment before putting into service.

When BRAZING is required, the following procedures shall be carried out in the following order:

- A) Make sure the power to the unit is turned Off.
- B) Safely remove the refrigerant following local and national regulations. If the recovery is not required by national regulations, drain the refrigerant to the outside. Take care that the drained refrigerant will not cause any danger. In doubt, one person should guard the outlet. Take special care that drained refrigerant will not float back into the building.
- C) Purge the refrigerant circuit with oxygen free nitrogen.
- D) Evacuate the refrigerant circuit.
- E) Purge the refrigerant circuit with oxygen-free nitrogen for 5 min.
- F) Evacuate again.

- G) Remove parts to be replaced by cutting or brazing.
- H) Purge the braze point with nitrogen during the brazing procedure required for repair.
- I) Carry out a leak test before charging with refrigerant.

When FLAMMABLE REFRIGERANTS are used:

- A) Evacuate the refrigerant circuit.
- B) Purge the refrigerant circuit with oxygen free nitrogen.
- C) Evacuate again.
- D) Cut out the compressor and drain the oil.

Disposal

Ensure sufficient ventilation in the work area.

Remove the refrigerant.

Where controlled, refrigerant-recovery is required, follow all local regulatory guidelines and requirements.

Where refrigerant recovery is not required by local/national regulations, drain the refrigerant to the outside. Take care that the drained refrigerant will not cause any danger. A designated person should oversee this process to ensure safety. Take special care that drained refrigerant will not drift back into the building during the draining process.

When FLAMMABLE REFRIGERANTS are used:

- A) Evacuate the refrigerant circuit.
- B) Purge the refrigerant circuit with nitrogen for 5 min.
- C) Evacuate again.
- D) Cut out the compressor and drain the oil.

