

Horizontal Series
FAN COIL TECHNICAL CATALOG

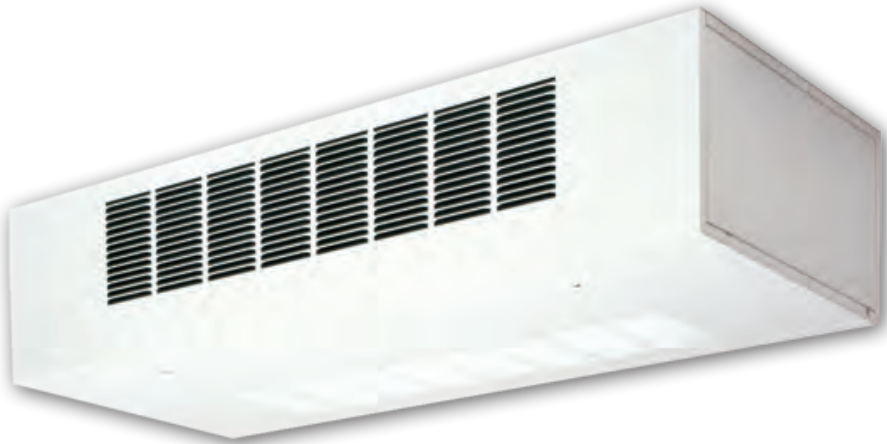

A **NIBE** GROUP MEMBER



Build your reputation on ours

Horizontal Series

FAN COIL TECHNICAL CATALOG

International Environmental Corporation (IEC) works continually to improve its products. As a result, the design and specifications of each product may be changed without notice and may not be as described herein. Please contact IEC for information regarding current design and product specifications. Statements and other information contained herein are not express warranties and do not form the basis of any bargain between the parties but are merely IEC's opinion or commendation of its products. Manufacturer's standard limited warranty applies.

Table of Contents

4-5	Portfolio
6	Features and Benefits
7	Unit Model Key
8	Ratings and Listings
9-18	Fan Performance Curves – PSC
19-28	Fan Performance Curves – ECM
29-30	Air Delivery
31	Motor Data
32-35	Sound Data
36	Electric Heating
37-60	Submittal Data
61-62	Air Flow Arrangements
63-71	Standard Features and Options
72	Piping Packages (Typical)

Portfolio

Horizontal Hideaway (CHY) 200 CFM to 1200 CFM

The Horizontal Hideaway (CHY) fan coil unit is designed specifically to meet the many varied requirements for a ceiling hideaway installation. The low-silhouette styling of the CHY makes this unit ideally suited for drop-ceiling and over-closet applications. Standard CHY units are constructed with 18 gauge galvanized steel and are provided with a galvanized finish.

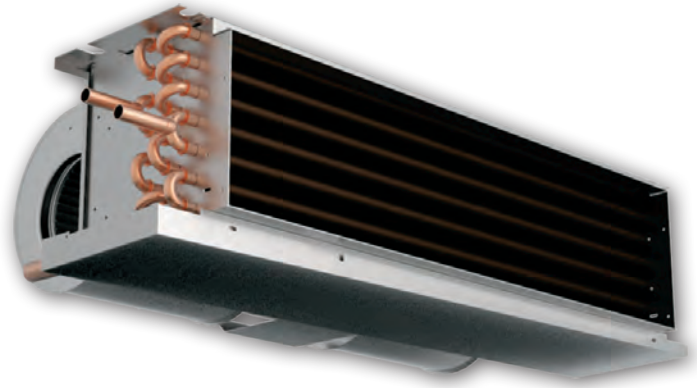

Horizontal Telescoping Hideaway (CBY) 200 CFM to 1200 CFM

The Horizontal Telescoping Hideaway (CBY) fan coil unit is mounted fully-recessed for ceiling-recessed applications. The CBY's telescoping frame with hinged panel adapts to any ceiling type and ensures exact alignment of the panel with the ceiling. The hinged-bottom panel provides easy access to all internal components. Standard CBY units are constructed with 18 gauge galvanized steel and are provided with a galvanized finish on the cabinet and powder-coat paint finish on the bottom-access panel.

Portfolio, Cont'd.

Horizontal Hideaway with Plenum (CPY)
200 CFM to 1200 CFM

The Horizontal Hideaway with Plenum (CPY) fan coil unit provides the same basic features of the CHY plus a return air plenum for above-ceiling mounting in closets, hallways or bathroom areas. The CPY design enables the unit to be adapted to installations requiring return air ducts or to be used as a return-air plenum with a unit-mounted filter and filter-rack assembly. CPY units are shipped from the factory ready for installation with the plenum section in place. No field fabrication is required. CPY units are designed with interchangeable panels so that the unit may be modified on site to accommodate a rear or bottom return. Standard CPY units are constructed with 18 gauge galvanized steel and are provided with a galvanized finish.

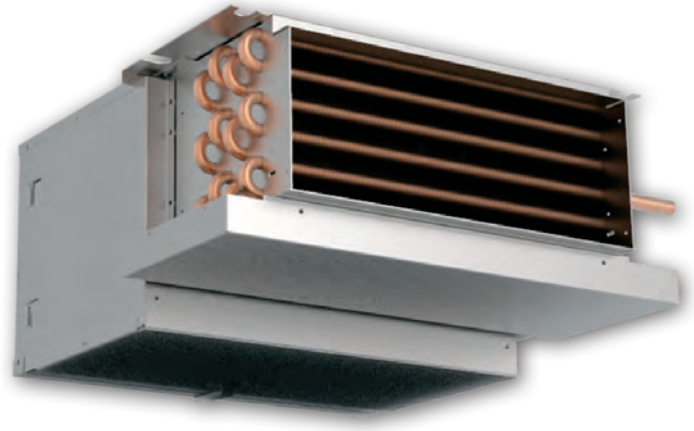

Horizontal Cabinet (CXB)
200 CFM to 1200 CFM

The Horizontal Cabinet (CXB) fan coil unit is designed specifically for exposed mounting in hotels, motels, hospitals, nursing homes, offices or other commercial establishments. With the CXB, valuable floor space is not required, and its slim, attractively-styled cabinet blends with all types of decor. Since there is no requirement for duct work or structure modifications, the CXB is ideal for retrofit applications. Standard CXB units are constructed with 18 gauge galvanized steel and are provided with a powder-coat paint finish.

Features and Benefits

Application Fit

- Multiple cabinet choices are available in 7 nominal CFM sizes for application in a variety of room layouts.
 - Horizontal Cabinet units (CXB) with aesthetically pleasing cabinetry offer capacities that are ideal for air conditioning in dormitories, small apartments, schools and many other applications. Front supply, bottom or rear return are available.
 - Horizontal Telescoping Hideaway units with painted access panel (CBY) allows smooth fit up to plaster or sheet rock ceilings. Standard units include bottom louvered return air with the filter located in the access panel.
 - Horizontal Hideaway models (CHY) units are installed above the ceiling with or without ducted supply air and open “soffit” return with an optional ceiling-mounted filter-grille.
 - Horizontal Hideaway models with plenum (CPY) units are installed above the ceiling with or without ducted supply air and ducted return air. The return air filter is either mounted on the unit plenum or installed in an optional ceiling filter-grille.

Design Flexibility

- Easy to use ratings program to speed up project design.
- Standard and high capacity hydronic coils are available to match the heating and cooling loads of the space.
- Optional powder-paint finish colors and grille selections will complement most décors (exposed units).
- CXB and CBY units ordered with optional rear return are constructed with a solid bottom panel.
- Customizable cabinetry makes these units ideal for renovation jobs or where special sizes are required to fit oversized valves and control packages.
- Optional airflow configuration (front supply, bottom supply, rear return or bottom return) to meet certain design limitations.

- Outside air connections are available to meet ventilation requirements and reduce field labor (CXB/CBY/CPY).
- Wide variety of factory assembled valve packages to meet desired controls specifications.
- Optional condensate float switch to address latest building codes where required.
- Wide variety of optional insulation materials are available to address IAQ concerns.

Ease of Installation

- Factory assembled valve packages minimize piping work at the job site (shipped loose for field mounting).
- Optional unit mounted controls, service switches and fusing minimize the electrical work required on site.
- Units are tagged at the factory for clear identification on job site.
- Opposite end connection units may minimize the piping work on renovation jobs.

Ease of Service

- All components are accessible by simply removing the access panel.
- Removable drain pan standard, with option for an extended drain pan
- Filters can be replaced without tools or by opening the bottom panels on exposed units.
- Blower assembly easily removed from the rear of coil for service and cleaning.

Quality and Safety

- Every unit is tested and inspected at the factory for trouble free start-up.
- ETL and CETL listed.
- AHRI certified.

Unit Model Key

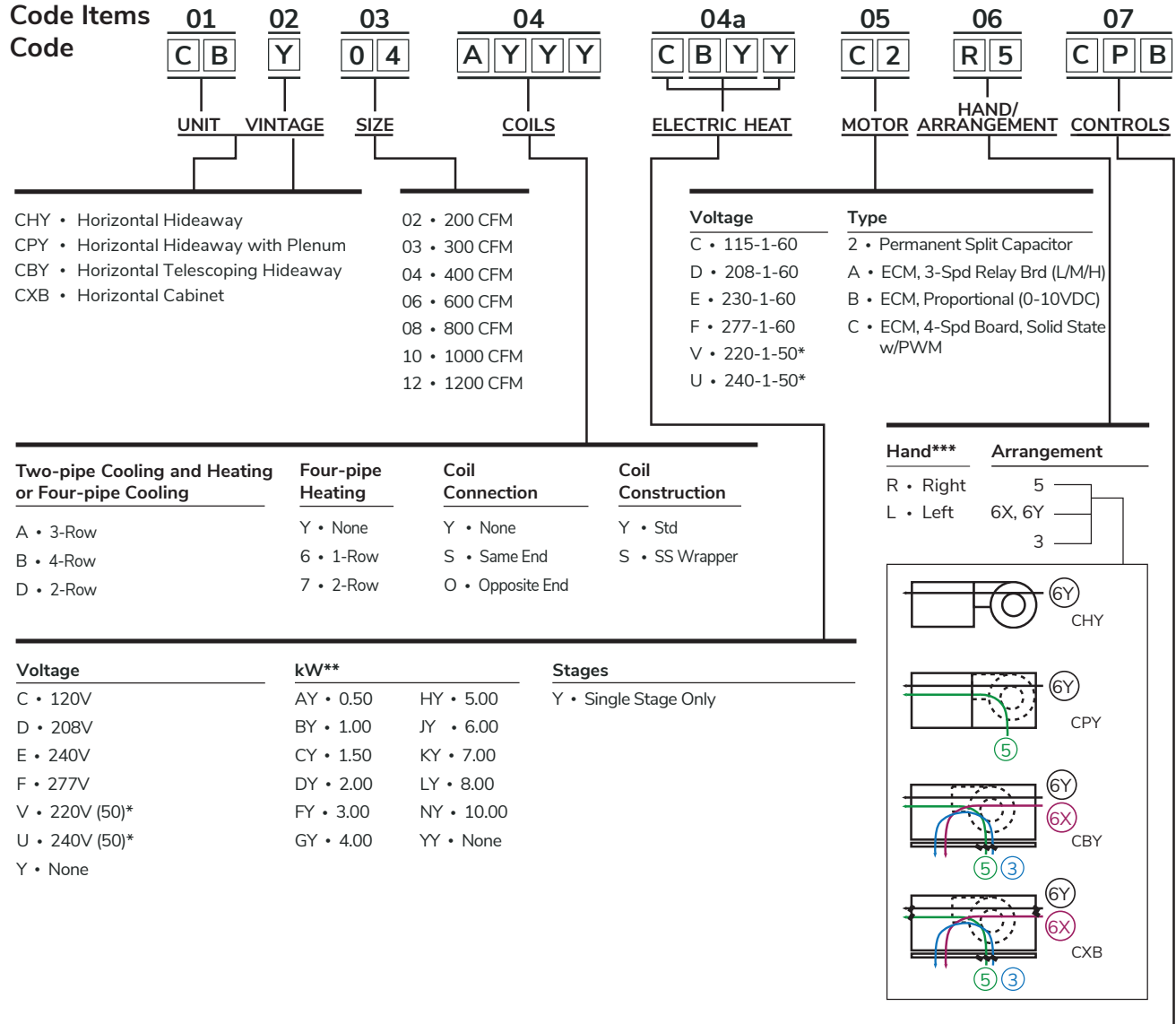

Voltage**

B • 24 V
C • 120V
D • 208V
E • 240V
F • 277V
V • 220V (50)*
U • 240V (50)*

System

Manual Fan Operation

A • Standard Unit Mount (Switch Only)

Function Control

G • 2 Pipe Heat Only
H • 2 Pipe Cool Only
K • 2 Pipe Heat and Cool
M • 2 Pipe Heat and Cool w/Aux. Elec. Heat
P • 2 Pipe Cool Only w/Total Elec. Heat
R • 4 Pipe Heat and Cool

Thermostat

A • Basic Electronic Wall Series, 155, Vertical
B • Basic Electronic Wall Series, 155, Horizontal
P • Basic 24V Digital, 7-Day Programmable
N • Basic 24V Digital, Non-Programmable
F • Premium 24V Digital, 7-Day Programmable/
BACnet with Proportional Fan/ Valves Option
G • Premium 24V Digital BACnet with
Proportional Fan/ Valves Option
W • Venture 24V Wi-Fi Programmable

* Consult factory for 50 Hz applications.

** Note that kW's depend on voltage and unit size.

*** Standing in front of the unit, hand is determined by looking into the air supply and assigning the hand to match the location of the cooling coil connections.

Horizontal Series

FAN COIL TECHNICAL CATALOG

Ratings and Listings

AHRI Certification

IEC's Horizontal Series units are certified in compliance with Air-Conditioning, Heating, and Refrigeration Institute (AHRI) industry standard AHRI-440 for room fan coil units. Approved standard ratings are tabulated below.



C-ETL-US Listing

IEC's Horizontal Series units are listed by ETL. The C-ETL-US listing signifies that IEC's fan coil units have been examined by ETL and are in compliance with both the U.S. and Canadian applicable standards.



Intertek
3061627

HEATING AND COOLING EQUIPMENT

Standard Ratings – PSC Motors

Model	Size	Coil Rows	Air Flow Rating (SCFM)	Water Pressure Drop (ft. water)	Total Cap. (Btuh)	Sensible Cap. (Btuh)	Power Input (Watts)
CBY, CHY, CPY	02	3	200	5.5	6,000	4,400	100
	02	4	190	12.0	6,900	4,300	100
	03	3	300	10.0	9,000	6,300	155
	03	4	270	15.0	9,800	6,500	100
	04	3	400	19.3	12,100	8,800	165
	04	4	400	35.0	13,800	9,800	155
	06	3	600	10.0	17,300	13,000	225
	06	4	600	17.0	19,600	14,300	180
	08	3	800	15.0	22,000	16,200	265
	08	4	700	25.0	25,500	18,800	260
	10	3	1,000	15.0	27,500	21,000	315
	10	4	1,000	25.0	31,000	22,000	310
	12	3	1,200	17.0	32,800	25,000	450
	12	4	1,200	27.0	37,200	27,700	485
CXB	02	3	200	5.0	6,000	4,400	90
	02	4	190	10.0	6,900	4,300	95
	03	3	300	10.0	9,000	6,300	100
	03	4	270	15.0	9,800	6,500	100
	04	3	400	19.3	12,100	8,800	165
	04	4	400	30.0	13,800	9,800	150
	06	3	600	5.7	17,730	13,000	225
	06	4	550	11.0	19,600	14,300	220
	08	3	725	12.0	21,700	16,000	235
	08	4	800	17.0	25,500	18,800	235
	10	3	900	7.5	25,400	19,500	305
	10	4	850	15.0	31,000	22,000	300
	12	3	1,150	12.0	32,800	25,000	385
	12	4	1,150	24.0	37,200	27,700	425

Standard Ratings – EC Motors

Model	Size	Coil Rows	Air Flow Rating (SCFM)	Water Pressure Drop (ft. water)	Total Cap. (Btuh)	Sensible Cap. (Btuh)	Power Input (Watts)
CBY, CHY, CPY	02	3	200	5.0	6,000	4,400	60
	02	4	190	12.0	6,900	4,300	87
	03	3	300	10.0	9,000	6,300	85
	03	4	270	14.0	9,800	6,500	75
	04	3	400	19.3	12,100	8,800	115
	04	4	400	35.0	13,800	9,800	145
	06	3	600	10.0	17,300	13,000	110
	06	4	600	17.0	19,600	14,300	115
	08	3	700	11.1	20,600	15,500	150
	08	4	695	25.0	25,500	18,200	165
	10	3	1,000	15.0	27,500	21,000	225
	10	4	1,000	25.0	31,000	22,000	265
	12	3	1,200	17.0	32,800	25,000	345
	12	4	1,200	27.0	37,200	27,700	330
CXB	02	3	200	5.0	6,000	4,400	65
	02	4	190	10.0	6,900	4,300	70
	03	3	300	9.0	9,000	6,300	65
	03	4	270	15.0	9,800	6,500	85
	04	3	400	19.3	12,100	8,800	165
	04	4	400	30.0	13,800	9,800	115
	06	3	550	11.0	19,600	14,300	220
	06	4	600	11.0	19,600	14,300	220
	08	3	730	12.0	21,800	15,800	170
	08	4	800	17.0	25,500	18,800	235
	10	3	1,000	8.0	27,500	21,000	265
	10	4	1,000	20.0	31,000	22,000	300
	12	3	1,150	12.0	32,800	25,000	275
	12	4	1,100	24.0	37,200	27,700	350

NOTES: 1. Ratings are based on 80°F DB and 67°F WB EAT, 45°F EWT, 10°F water temperature rise, high fan speed, motor voltage 115/1/60, and airflow under dry coil conditions.
 2. For all application ratings, use IEC's computer selection program, the quick-selection ratings provided in this catalog, or contact your local IEC representative.
 3. For additional information, please consult AHRI's website at www.ahrinet.org.

Fan Performance Curves – PSC

NOTE: Static pressure losses for factory-installed throwaway air filter and supply/return air grilles (where applicable) are included in all fan performance curves for all sizes.

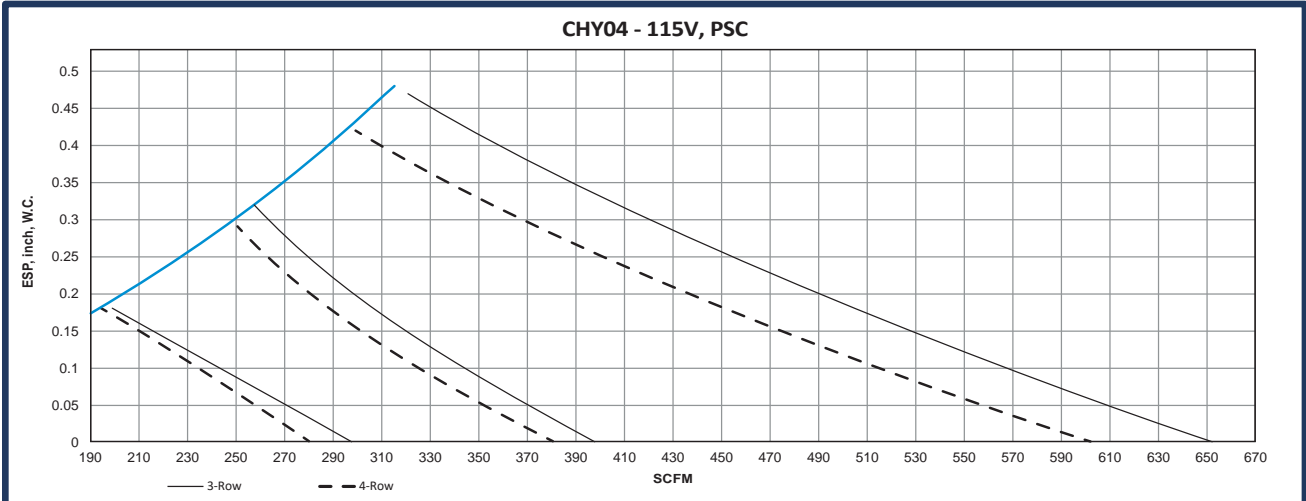
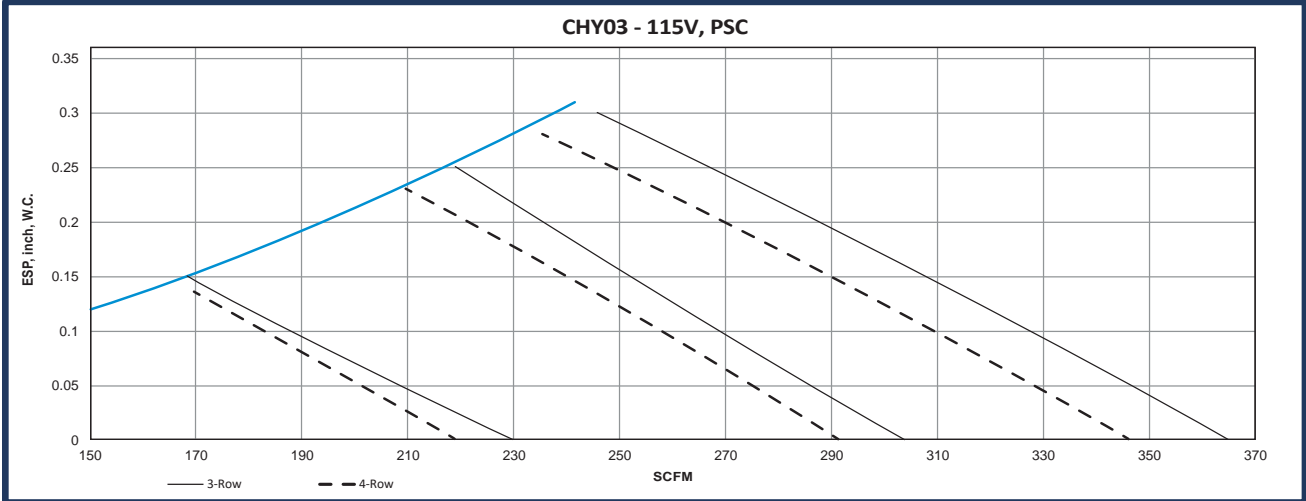
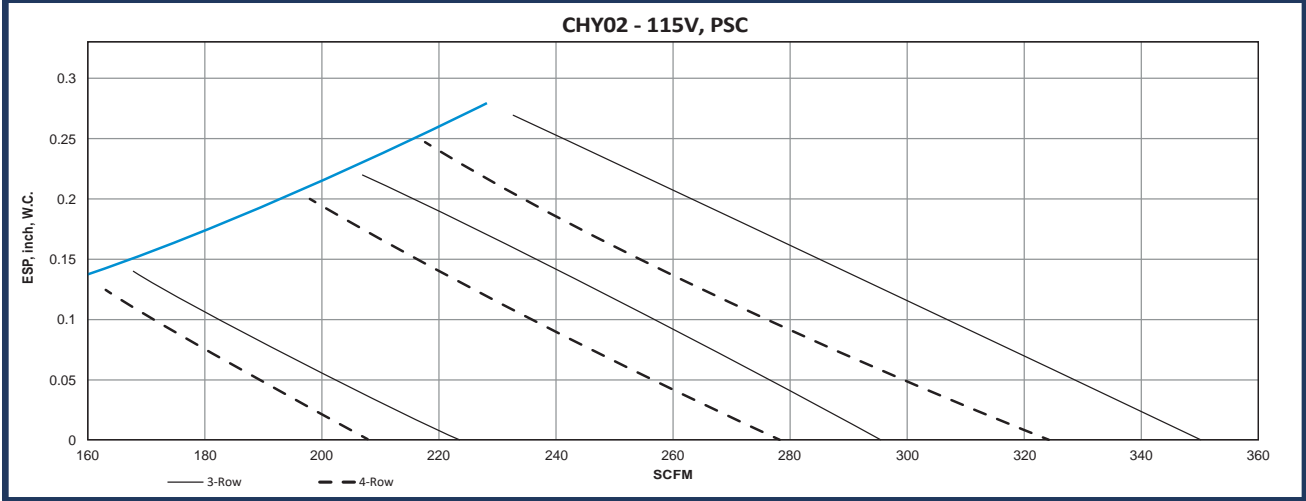

Fan Performance Curves – PSC, Cont'd.

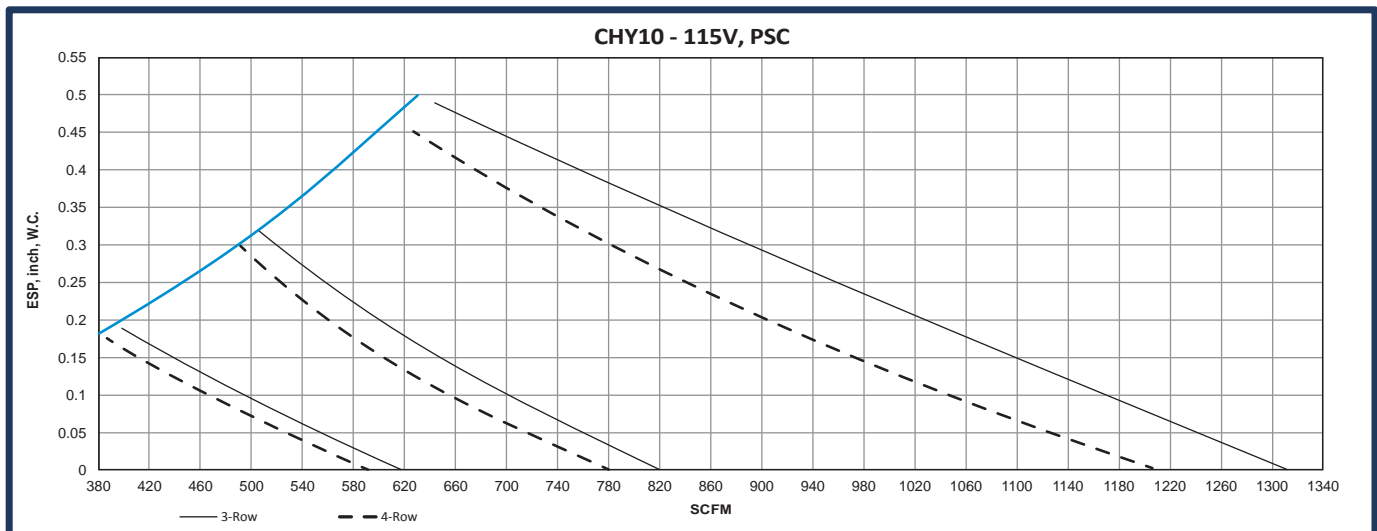
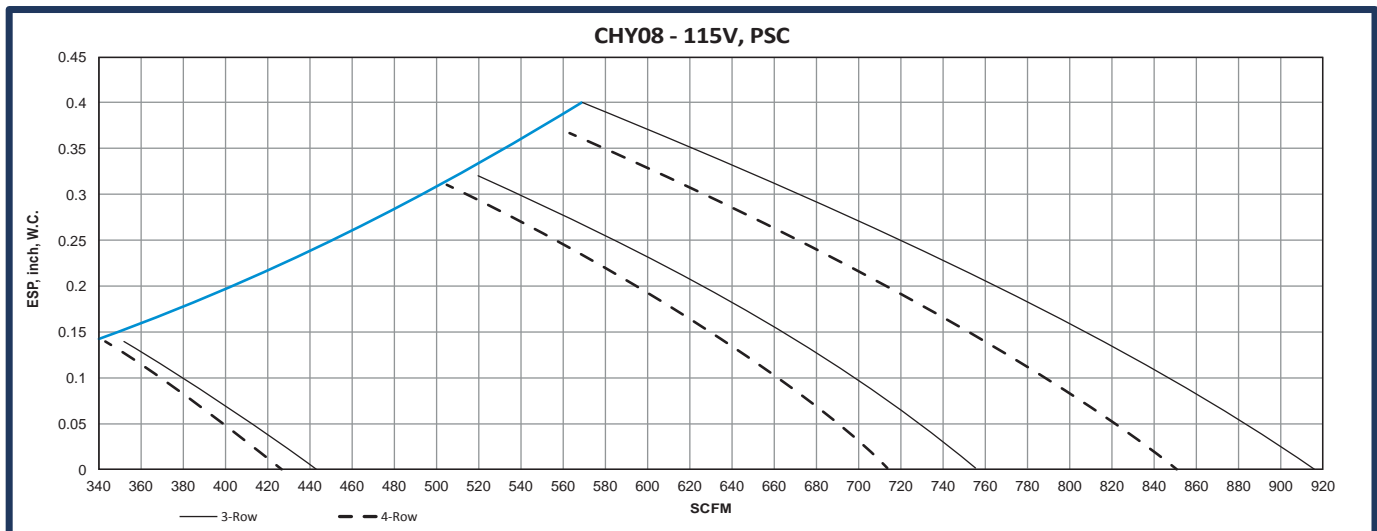
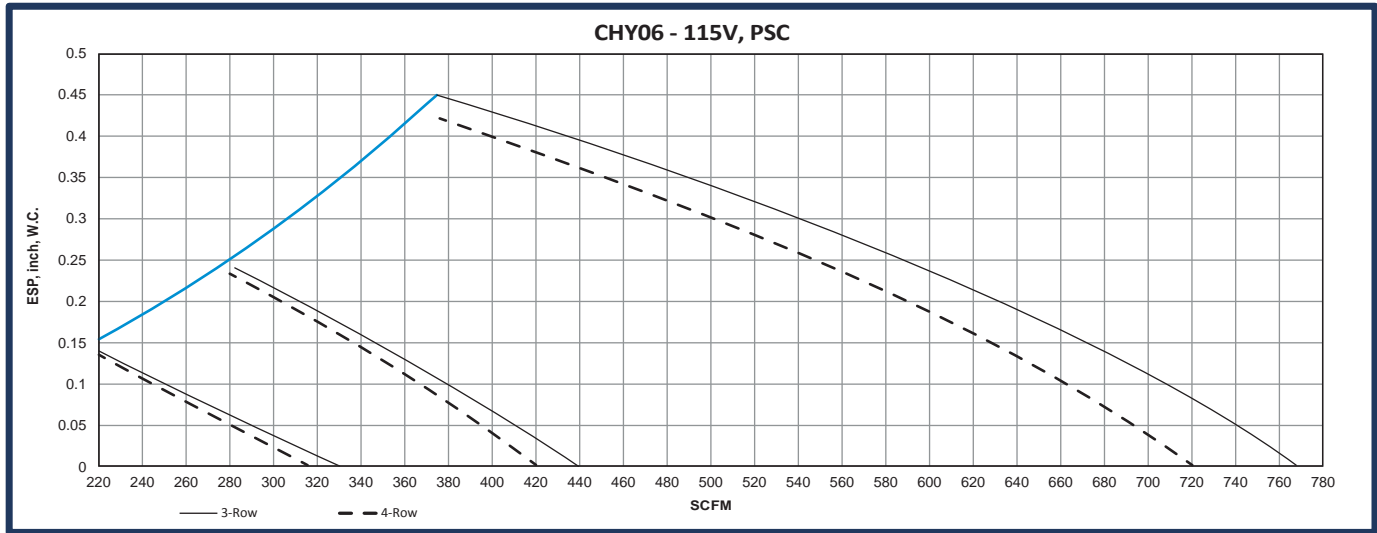

Fan Performance Curves – PSC, Cont'd.

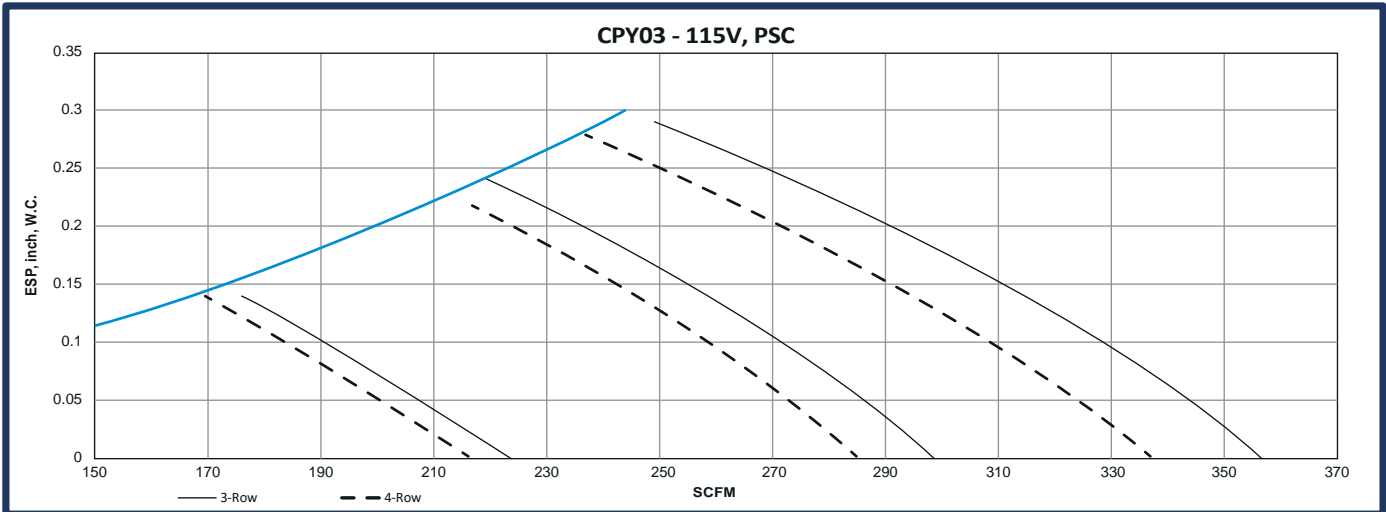
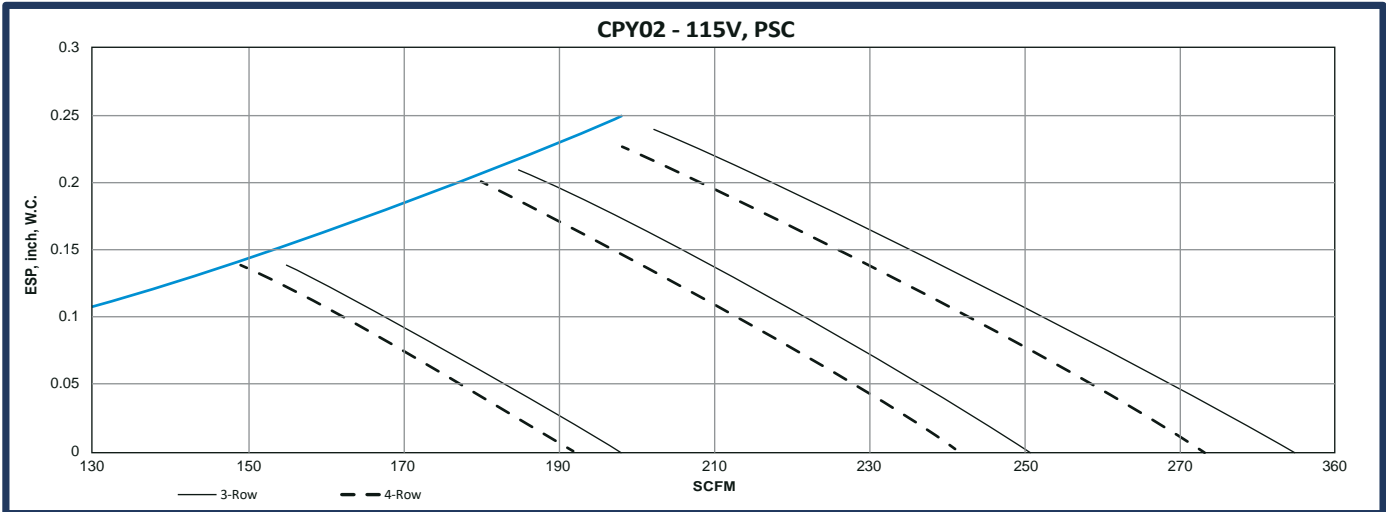
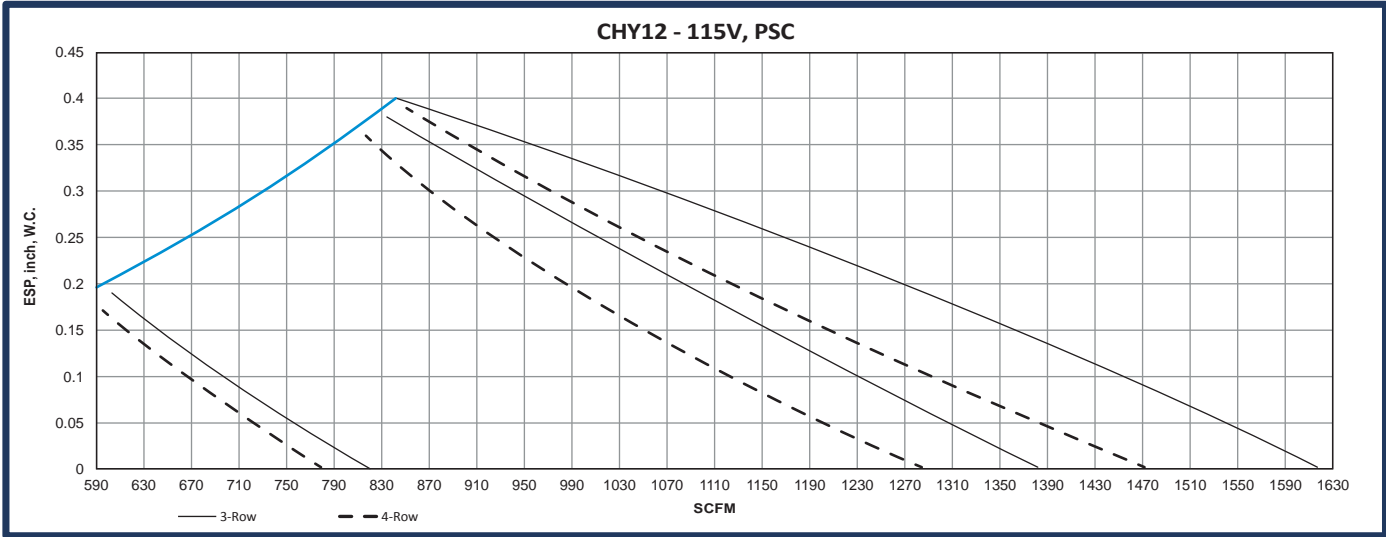

Fan Performance Curves – PSC, Cont'd.

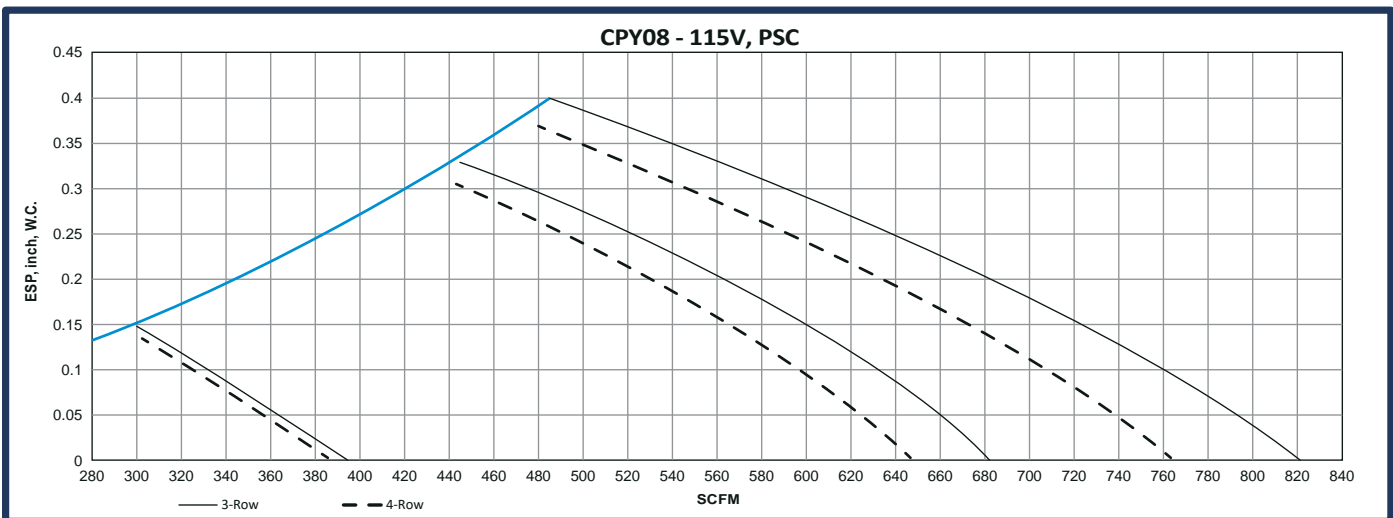
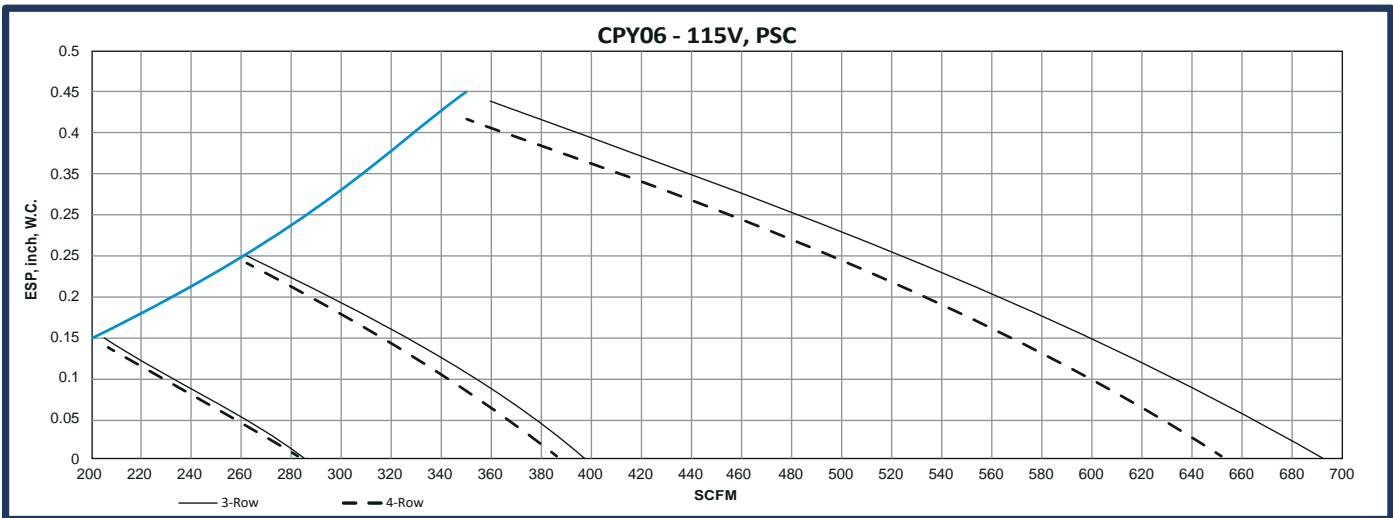
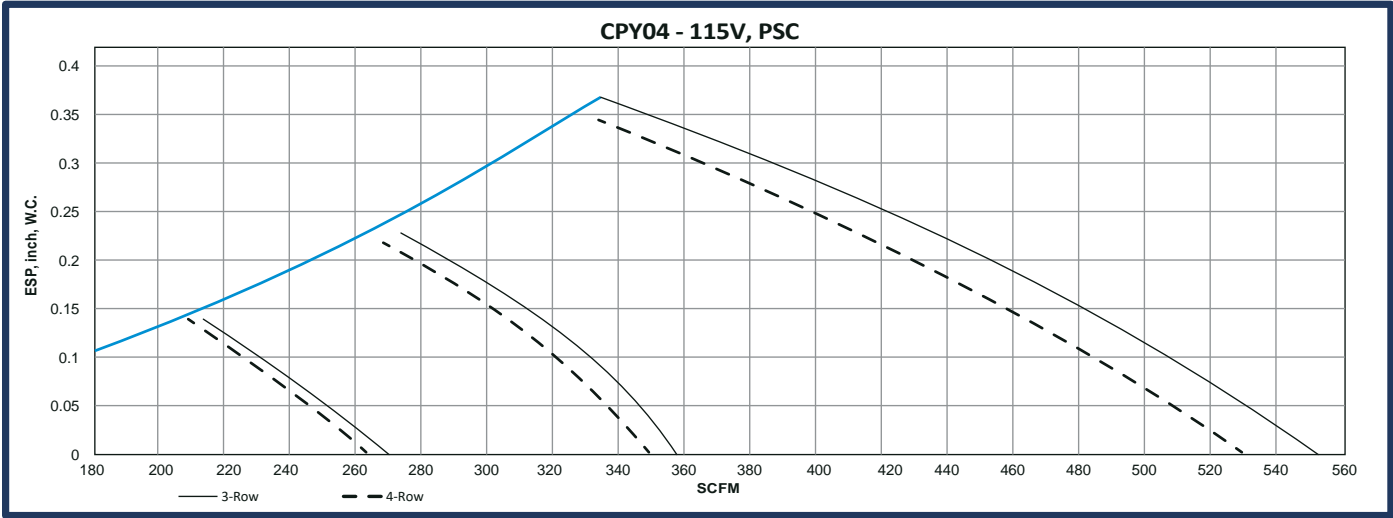

Fan Performance Curves – PSC, Cont'd.

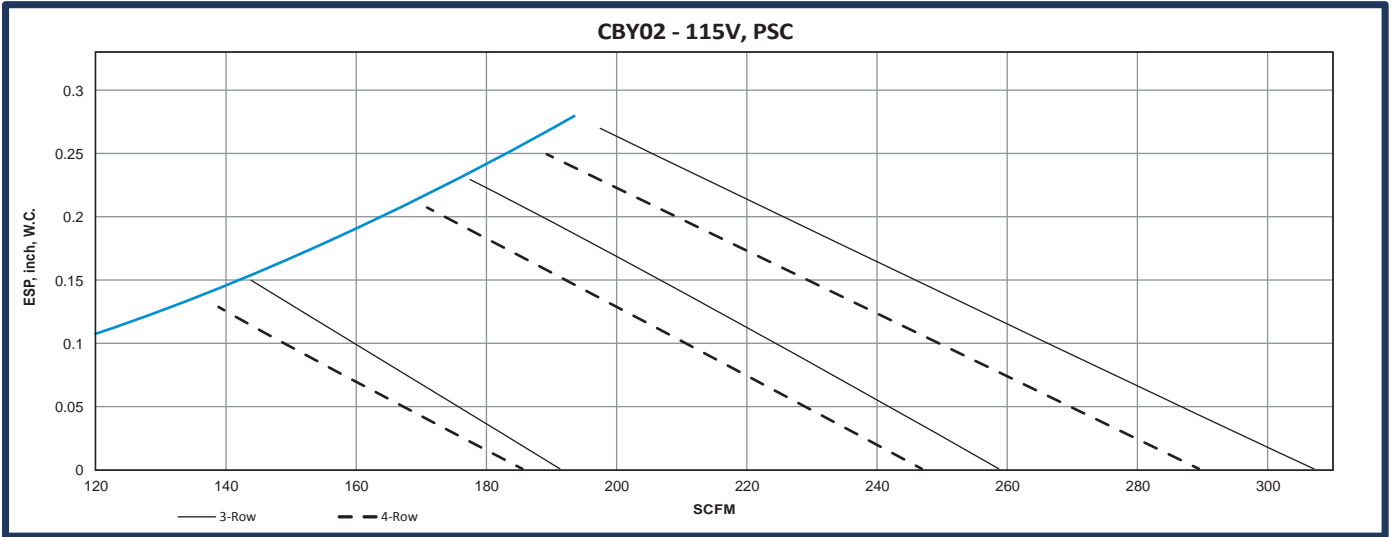
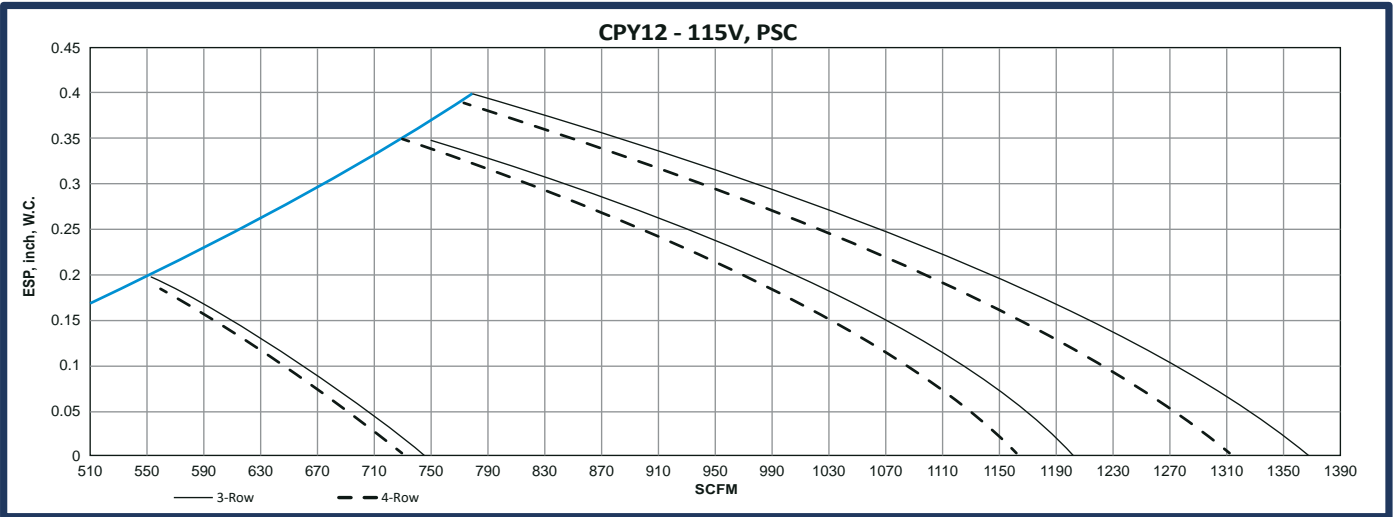
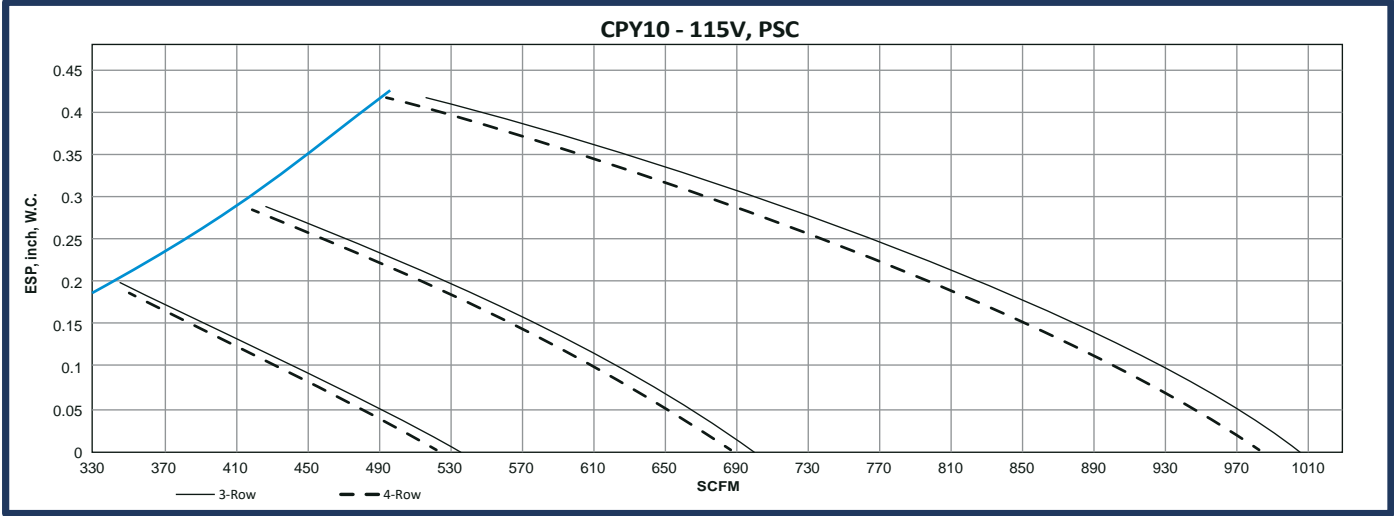

Fan Performance Curves – PSC, Cont'd.

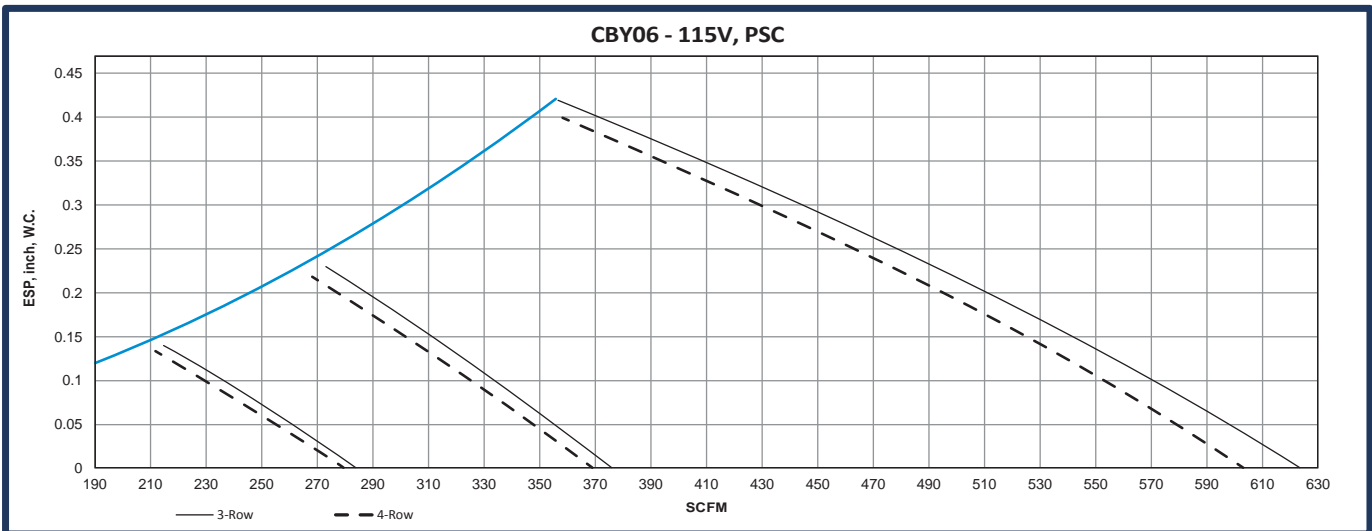
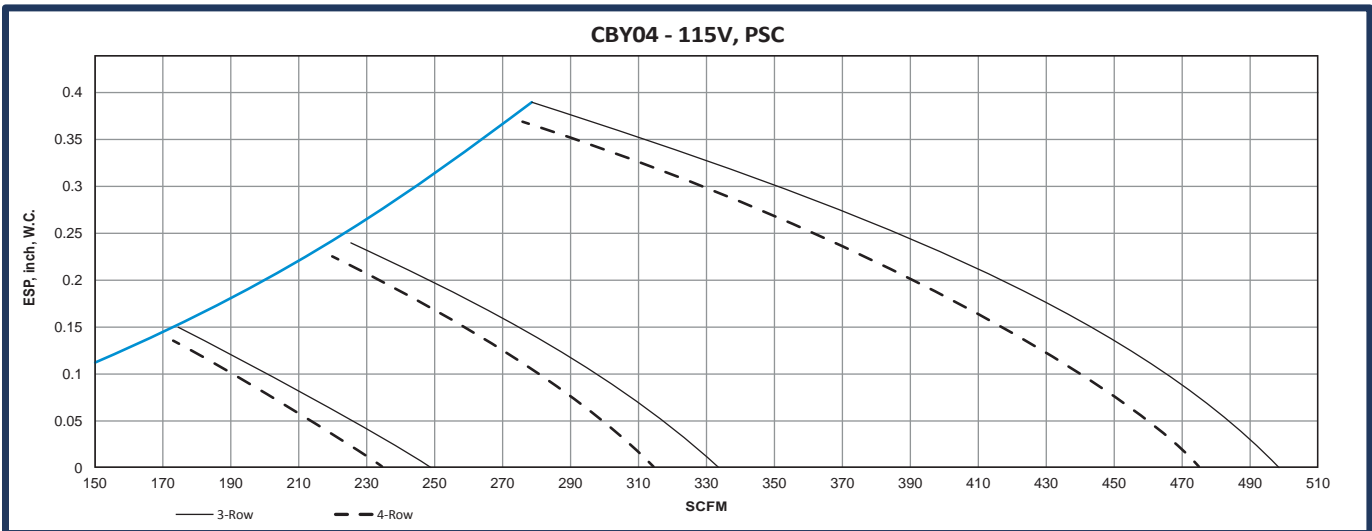
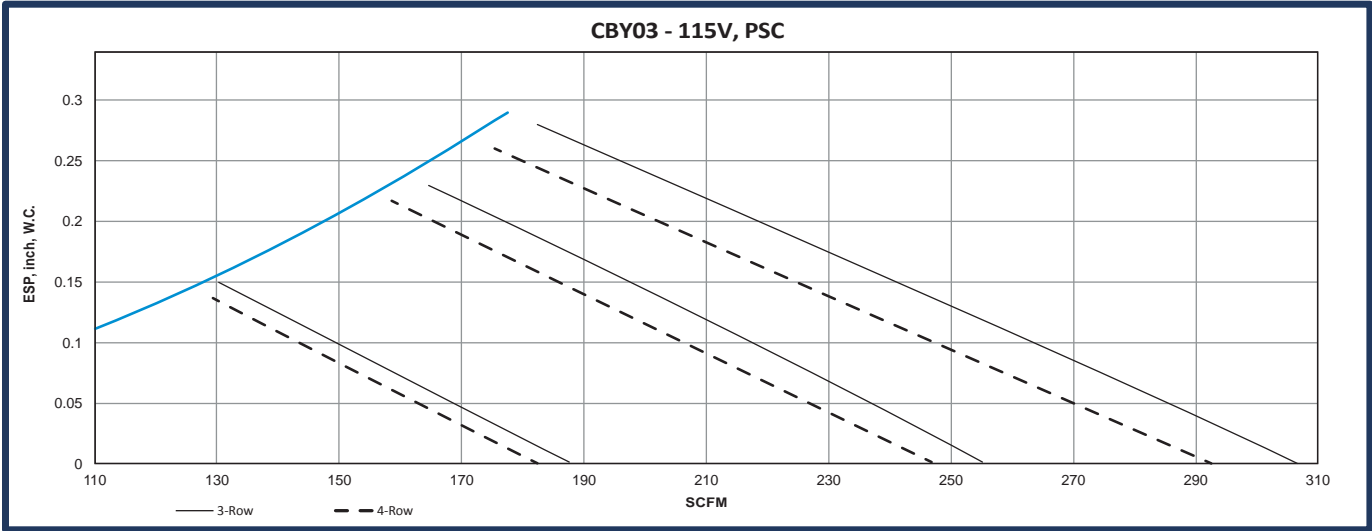

Fan Performance Curves – PSC, Cont'd.

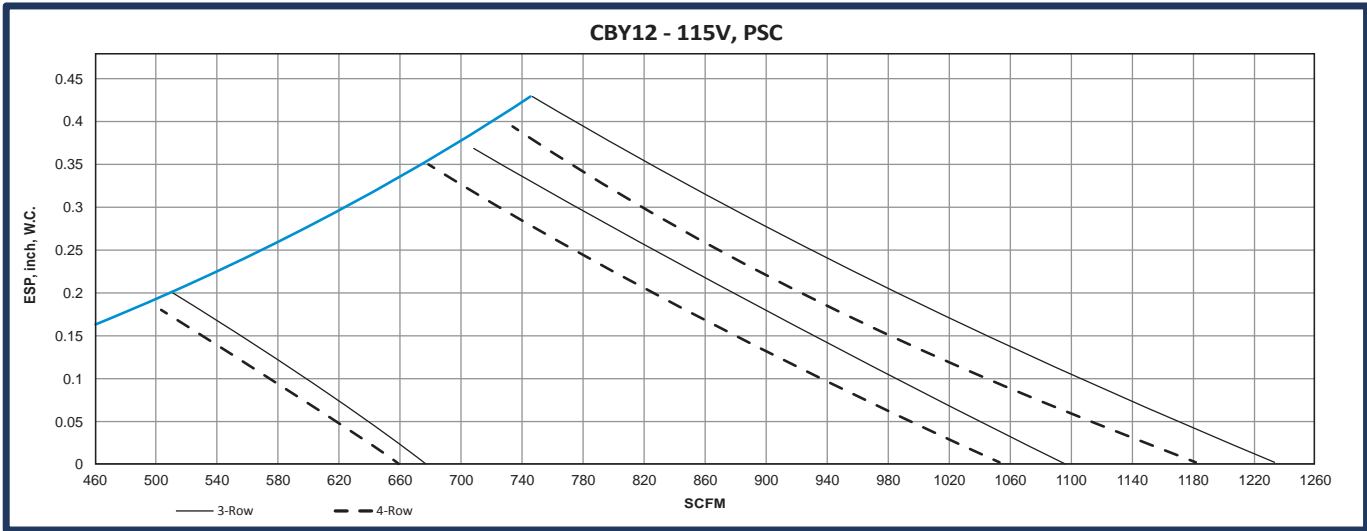
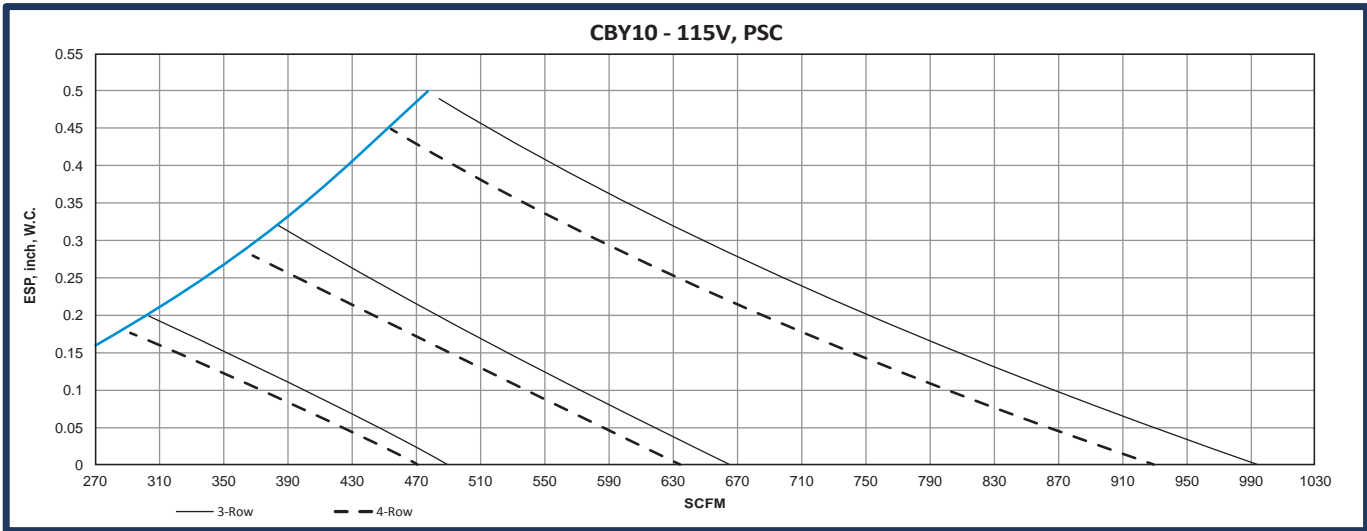
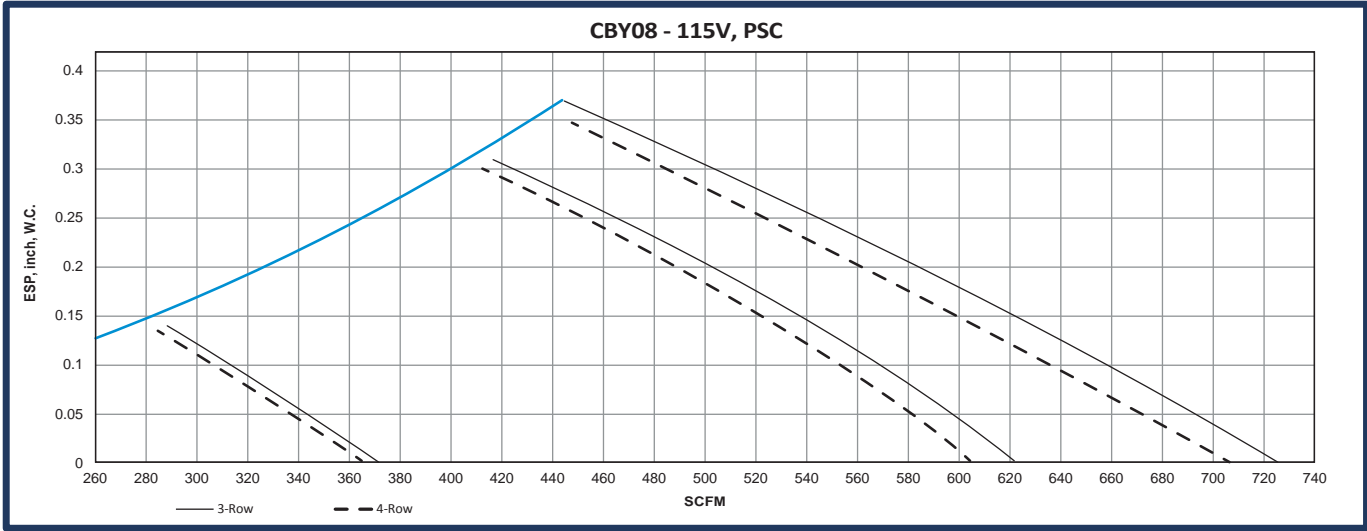

Fan Performance Curves – PSC, Cont'd.

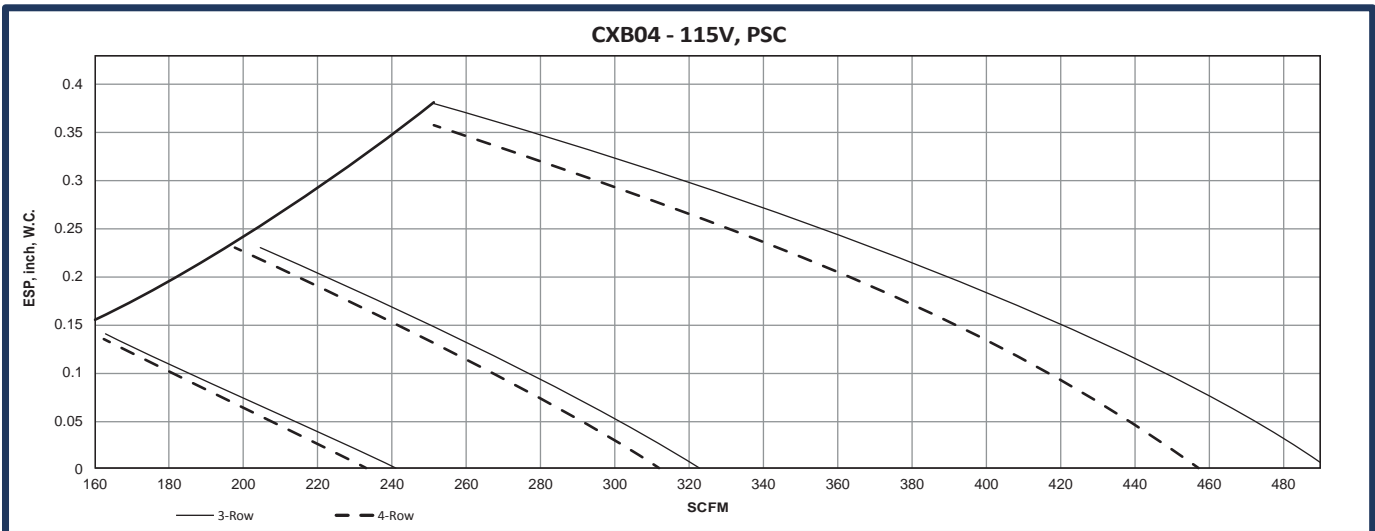
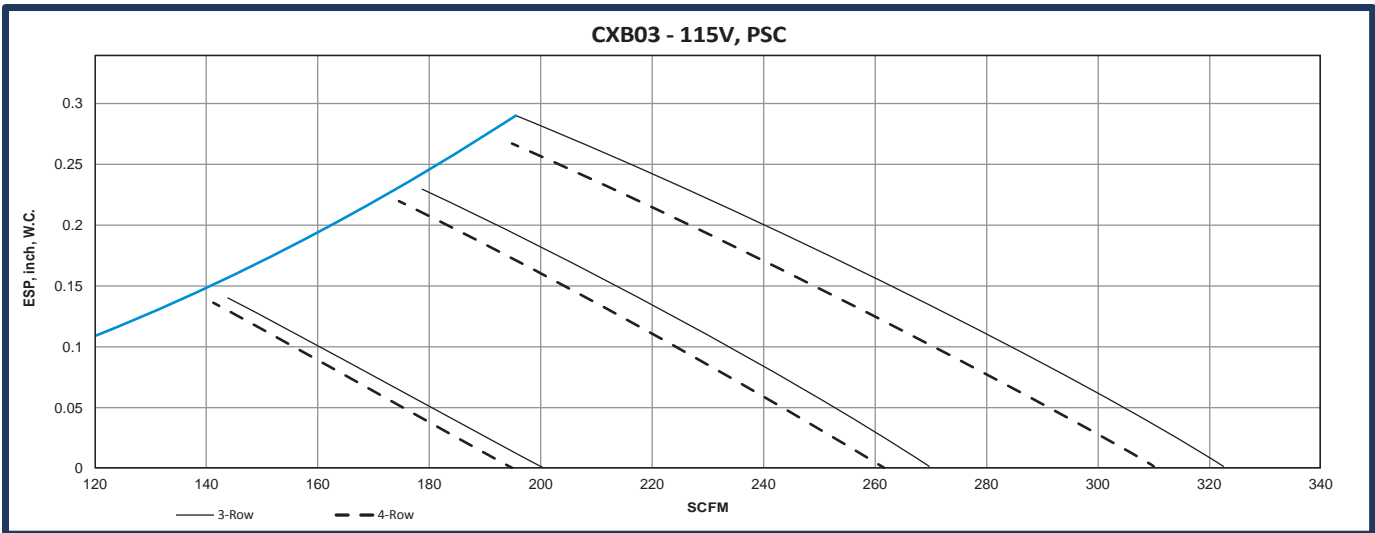
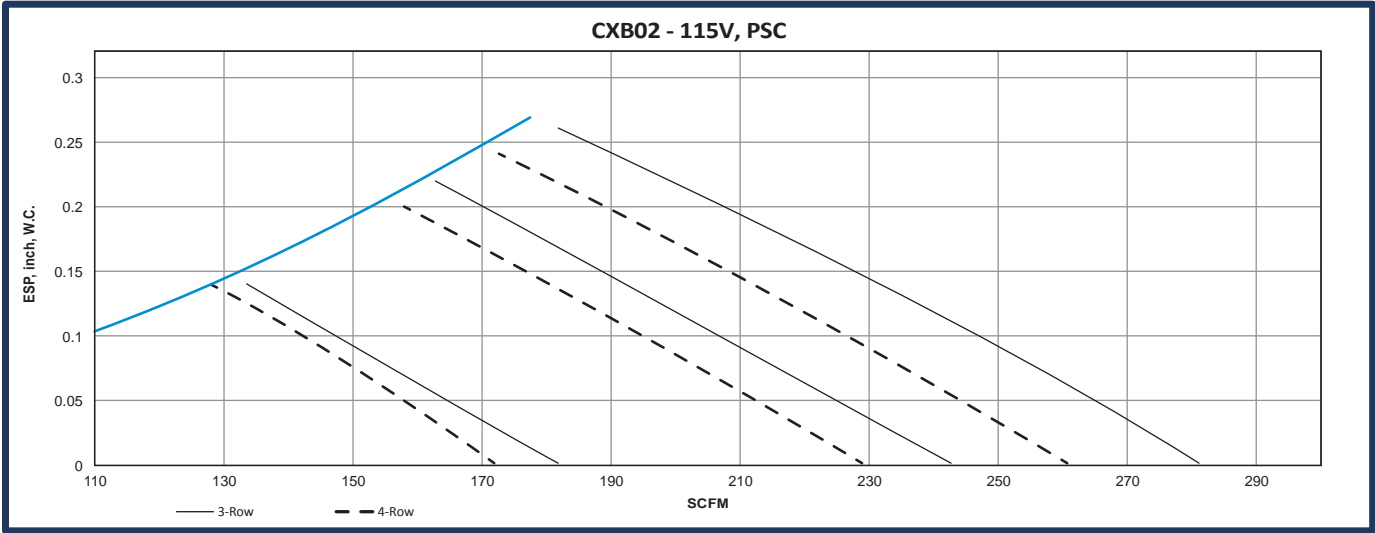

Fan Performance Curves – PSC, Cont'd.

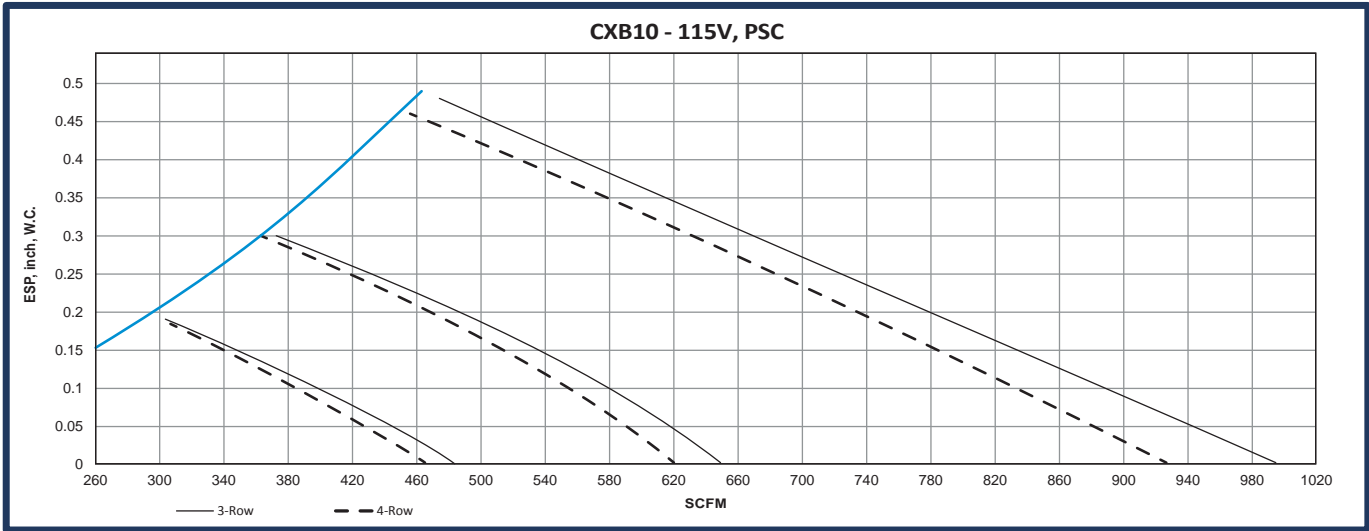
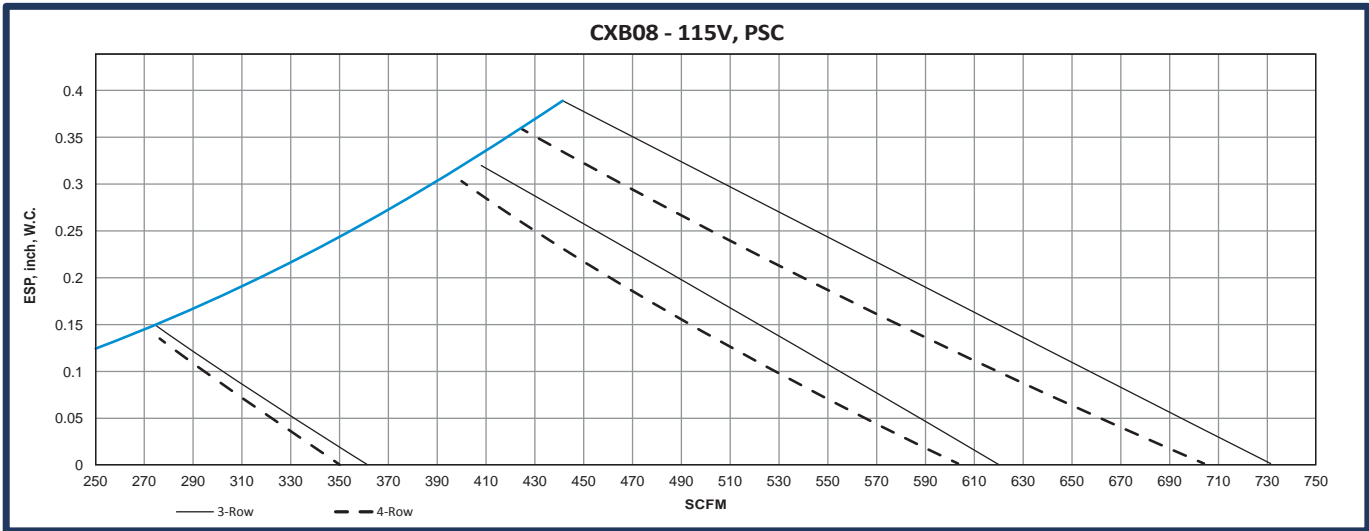
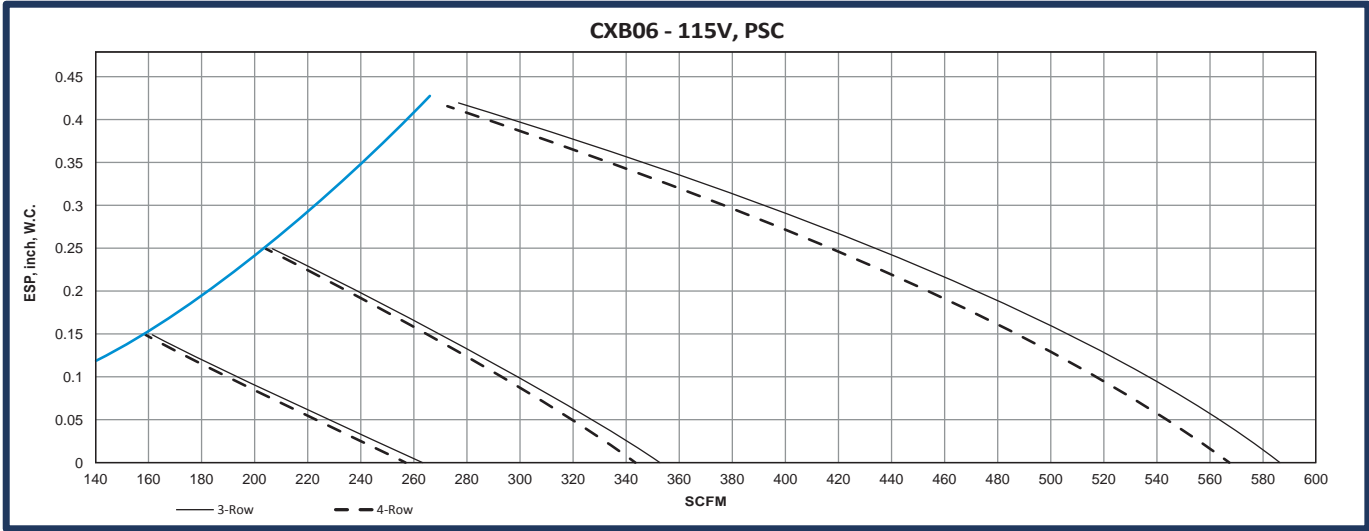

Fan Performance Curves – PSC, Cont'd.

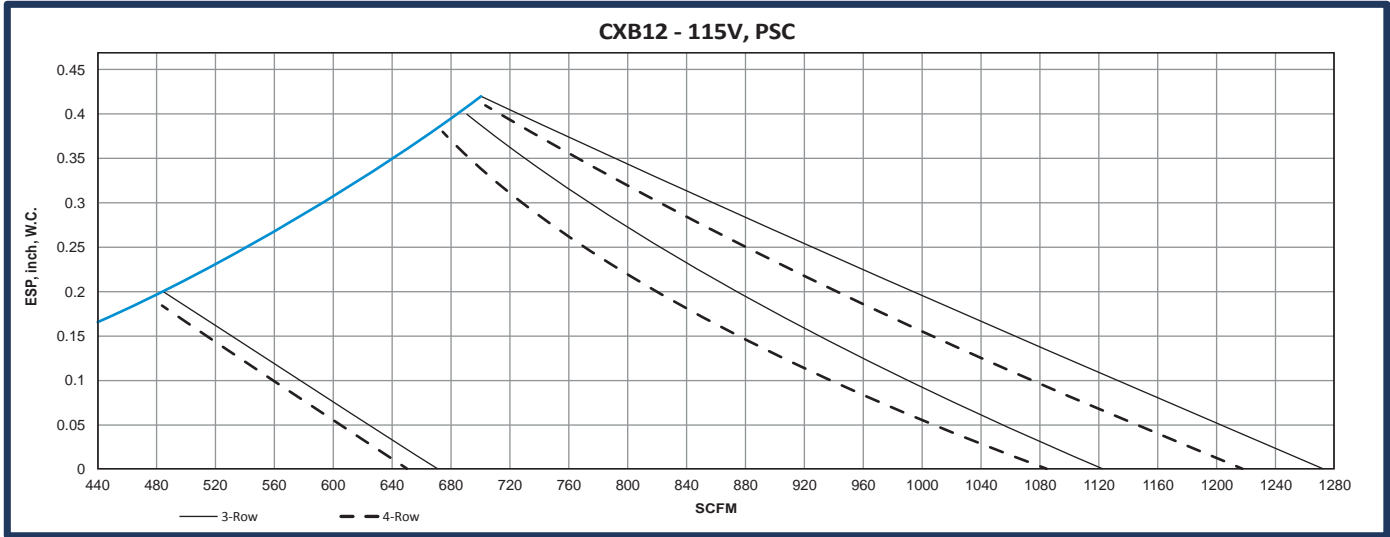

Fan Performance Curves – ECM

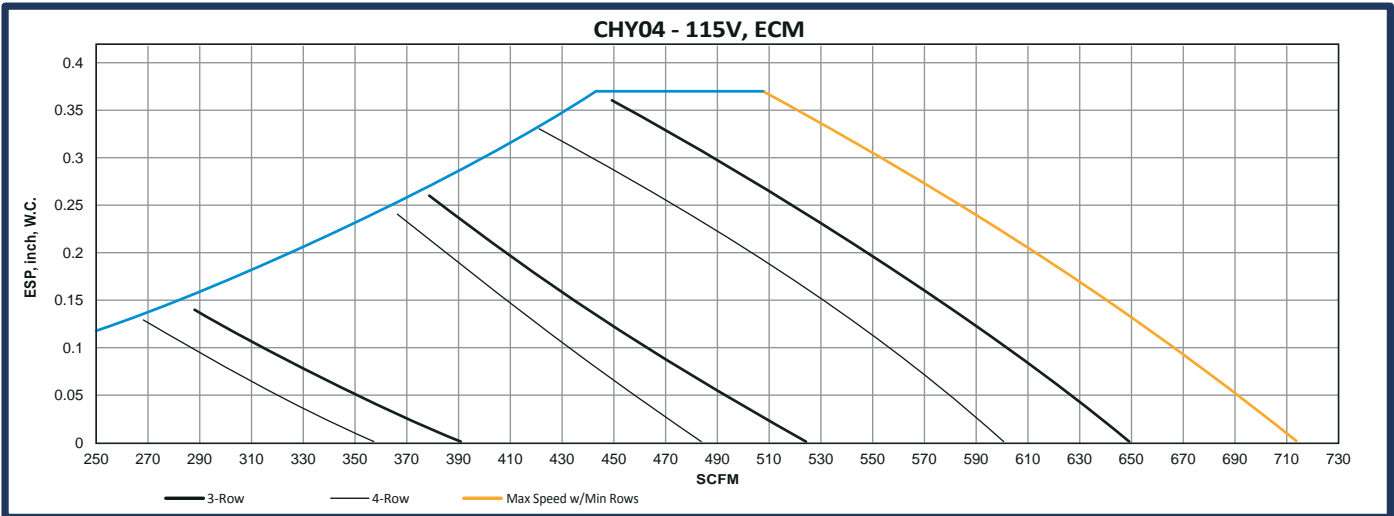
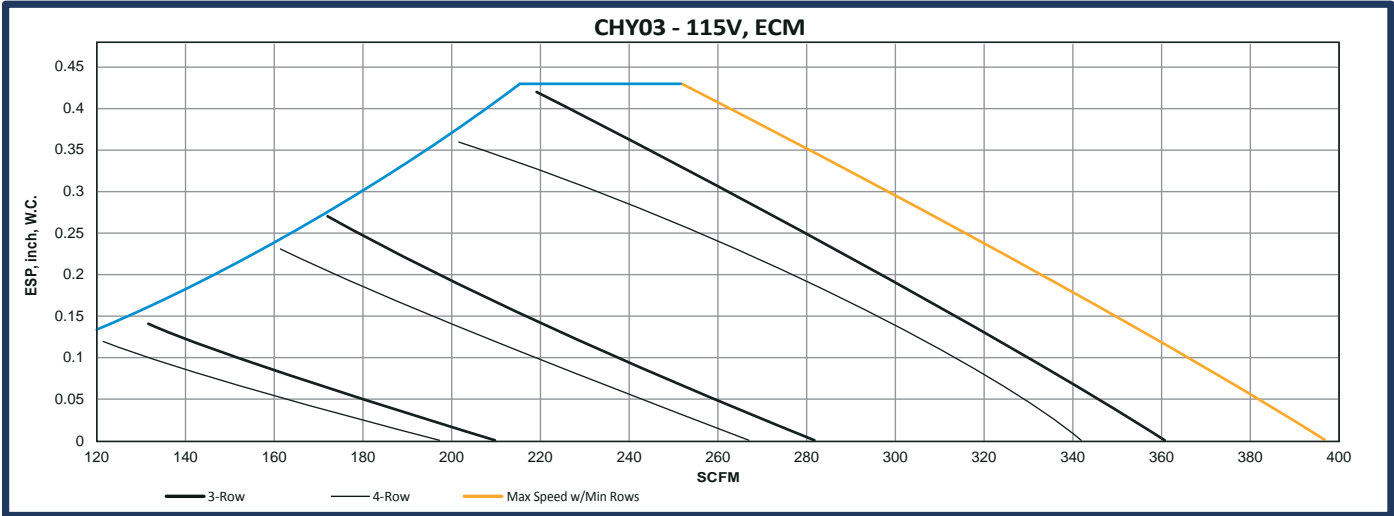
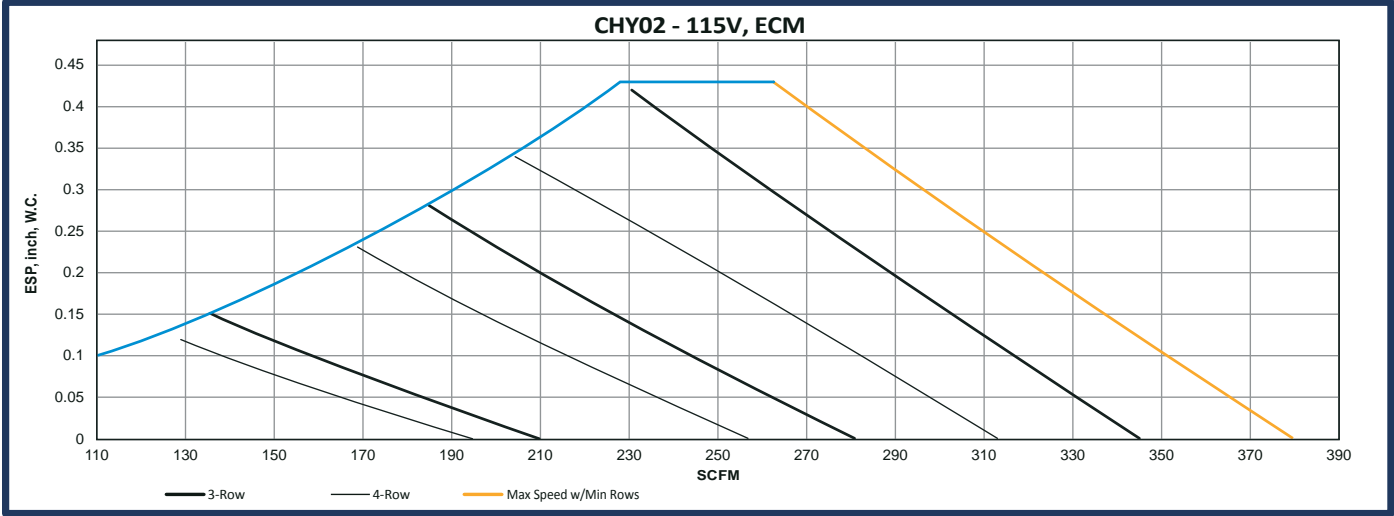

Fan Performance Curves – ECM, Cont'd.

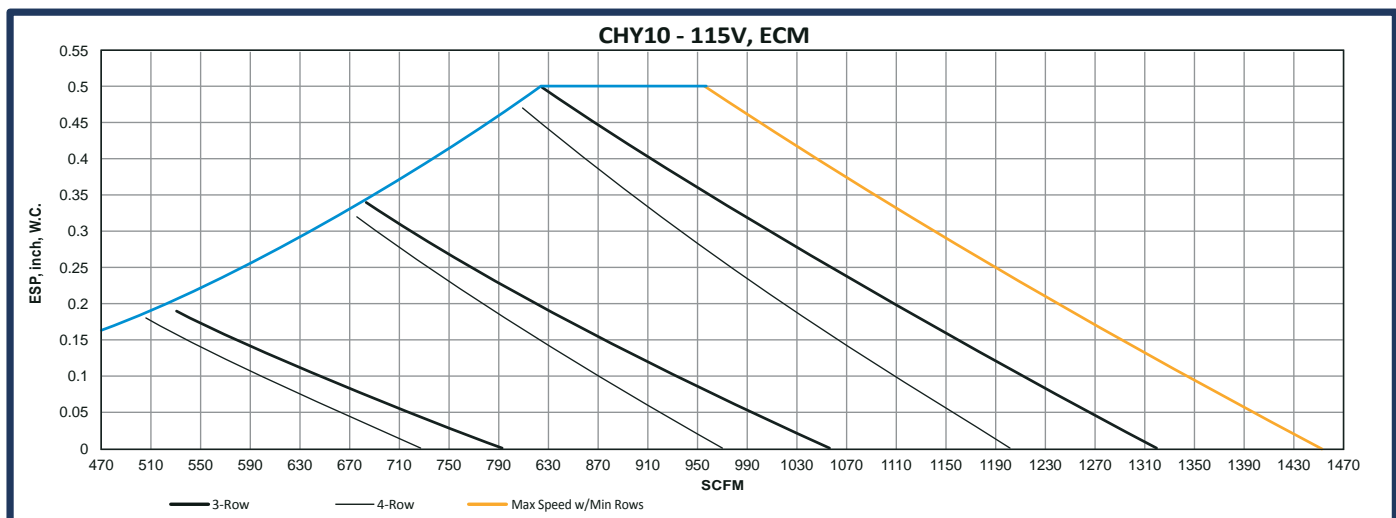
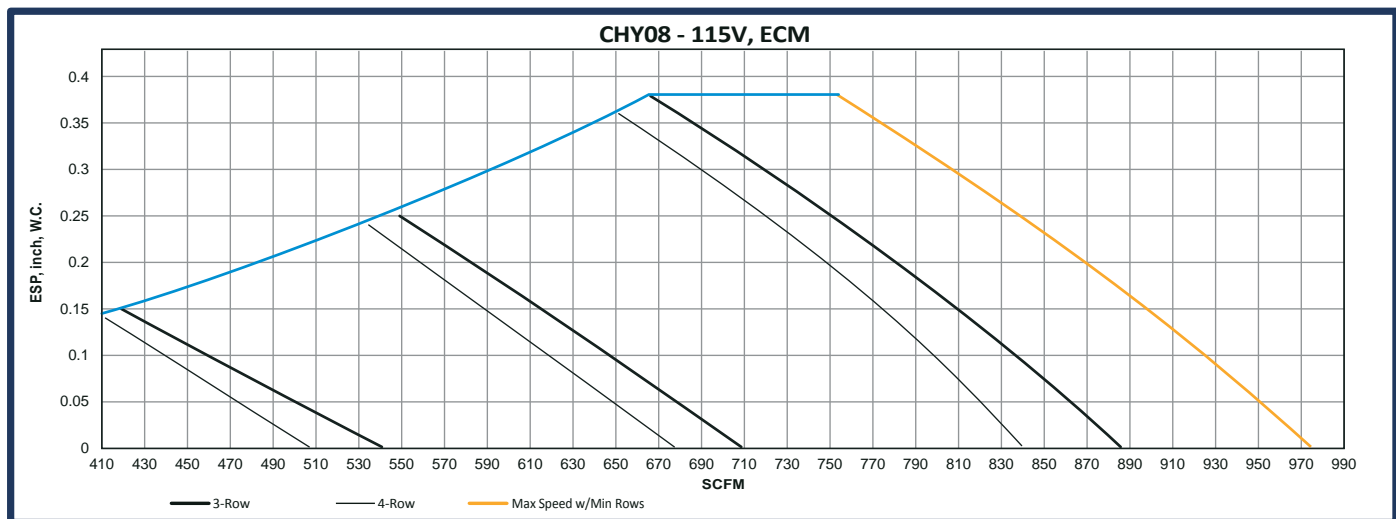
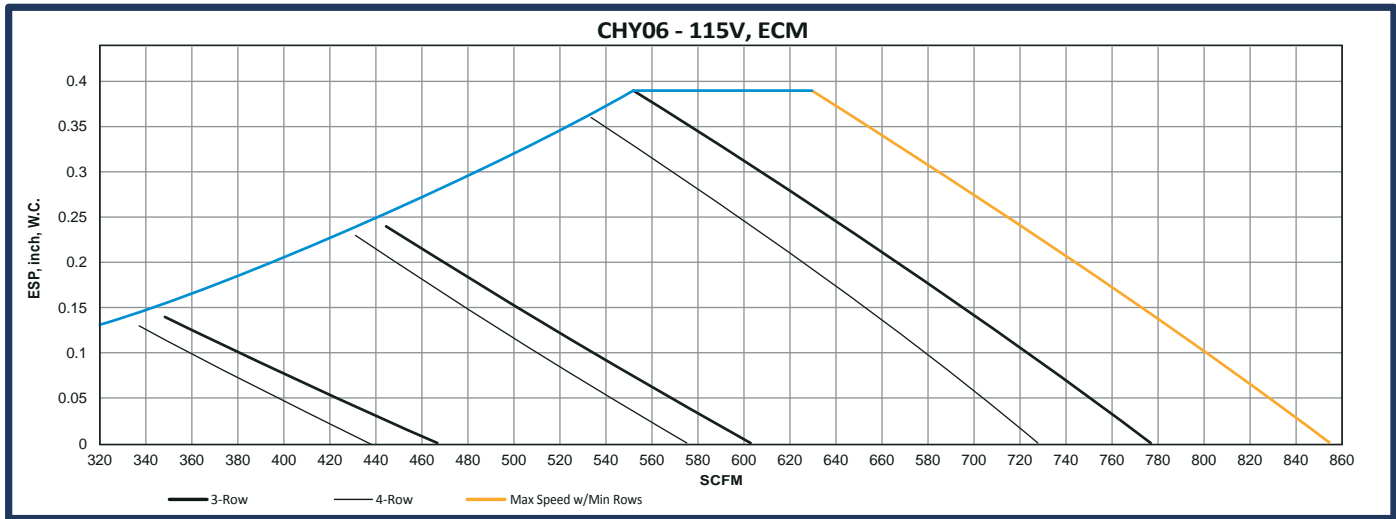

Fan Performance Curves – ECM, Cont'd.

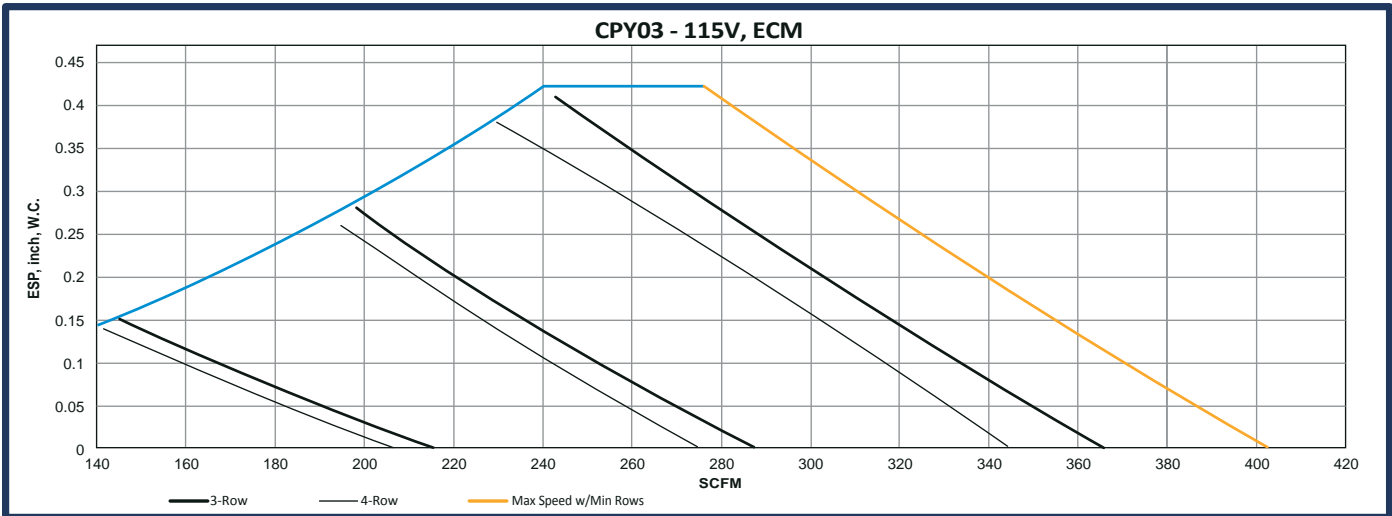
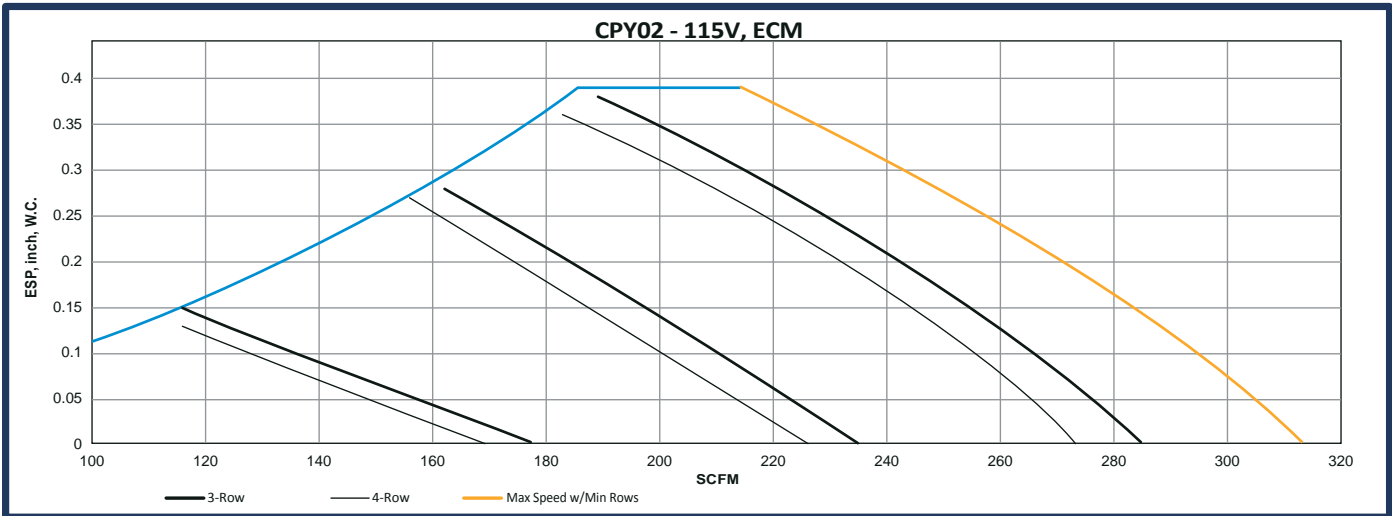
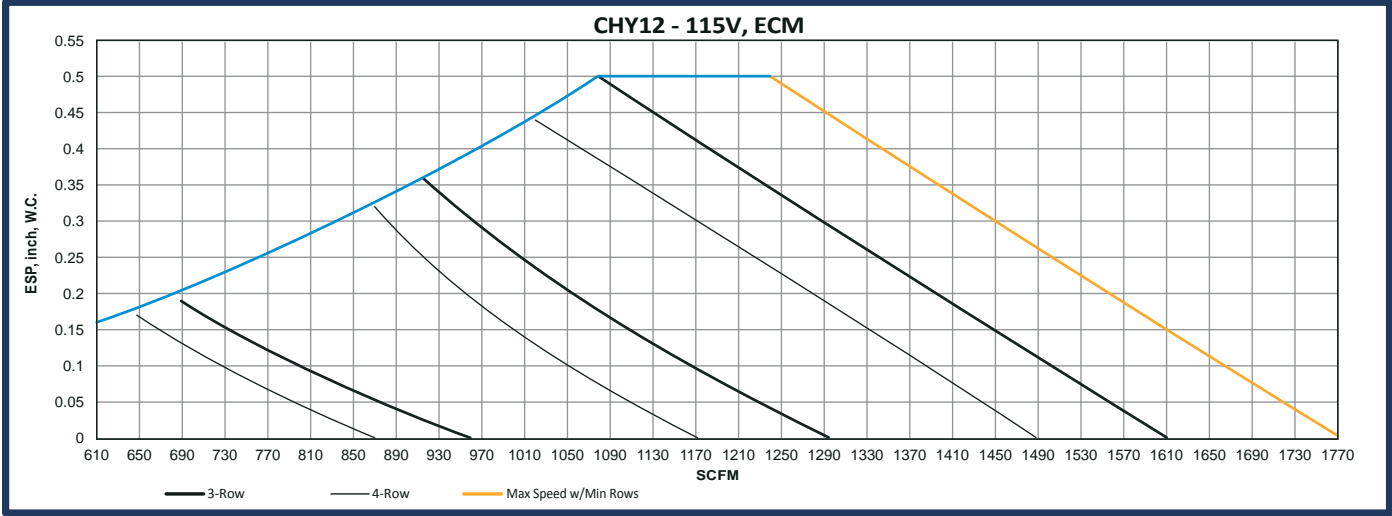

Fan Performance Curves – ECM, Cont'd.

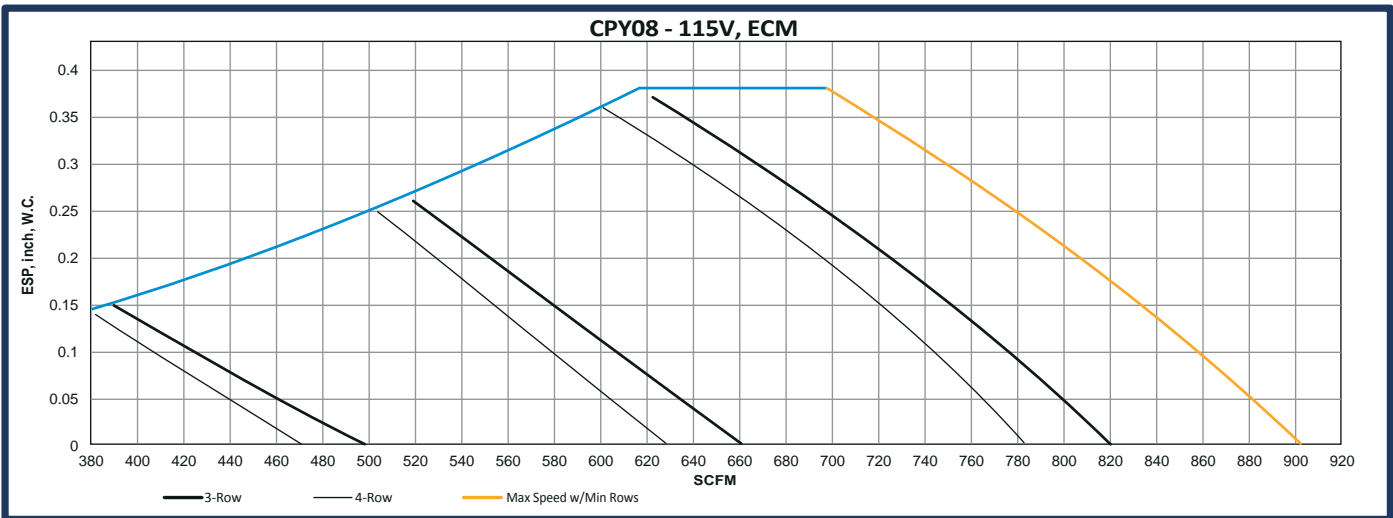
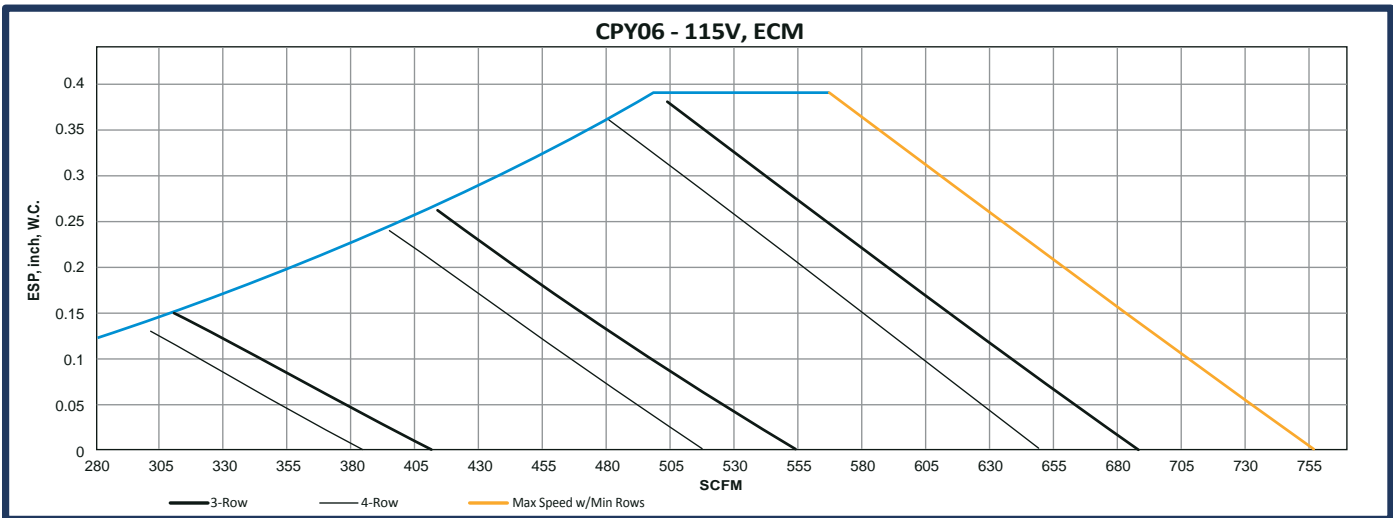
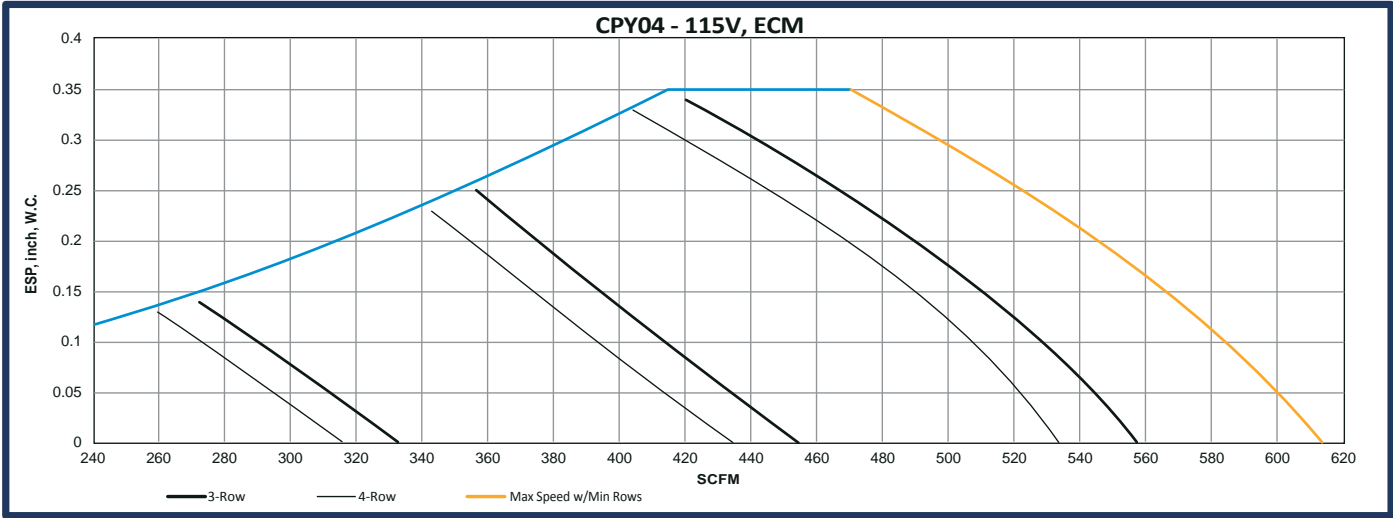

Fan Performance Curves – ECM, Cont'd.

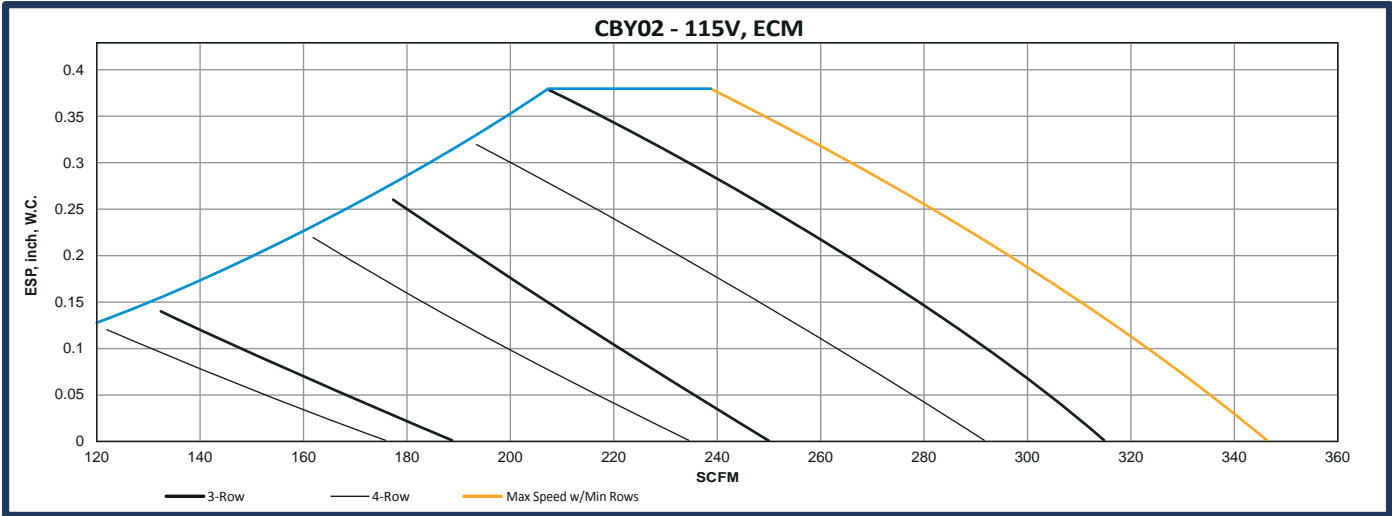
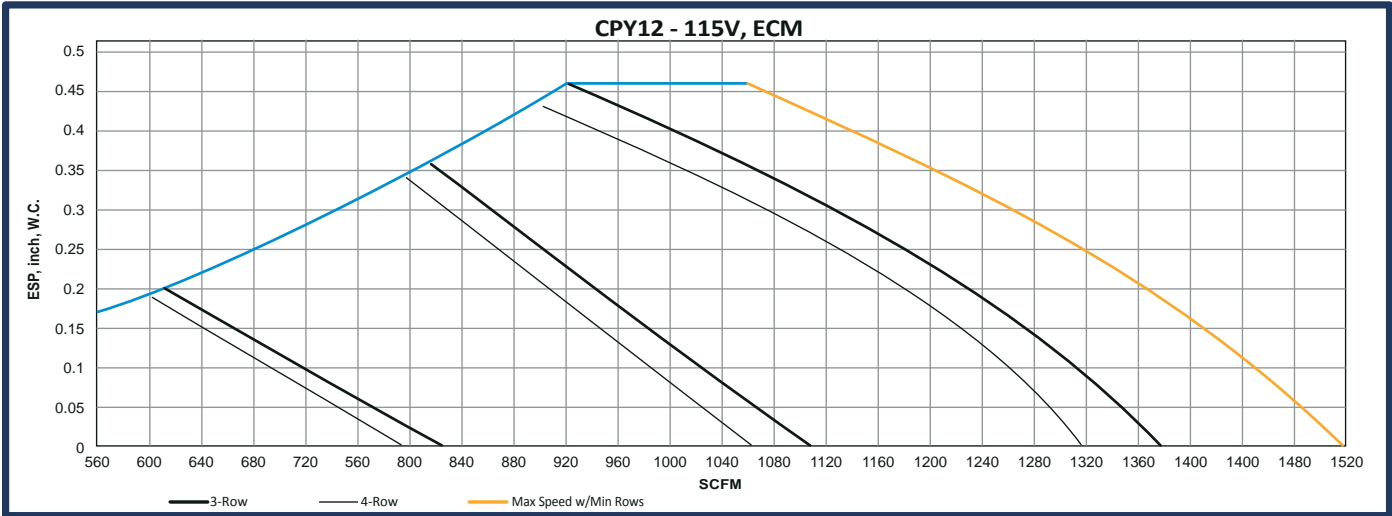
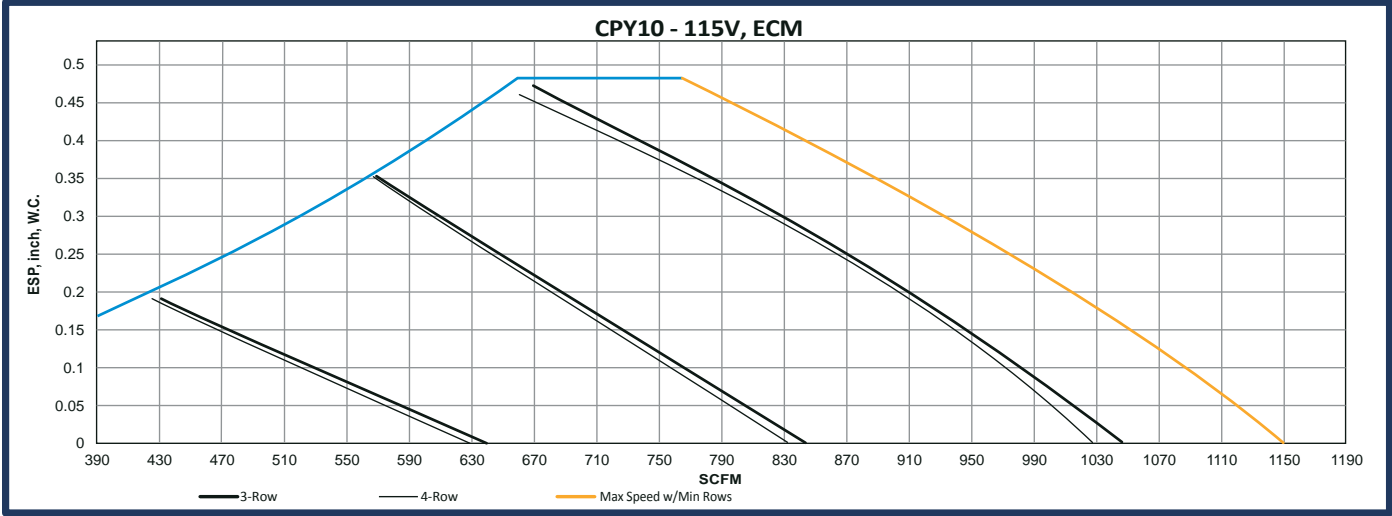

Fan Performance Curves – ECM, Cont'd.

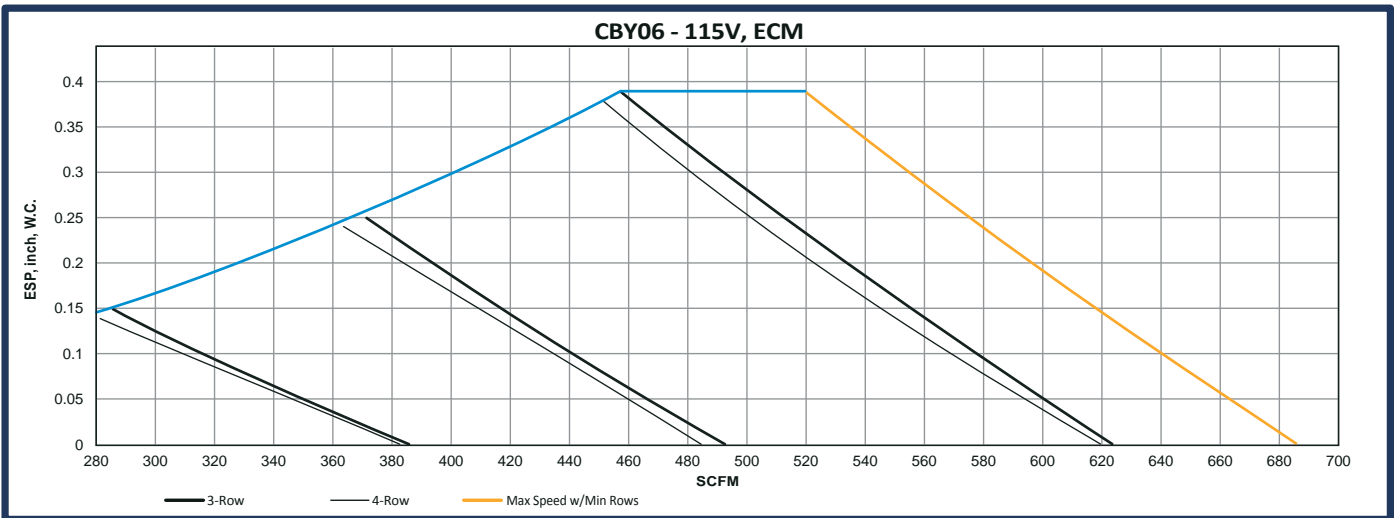
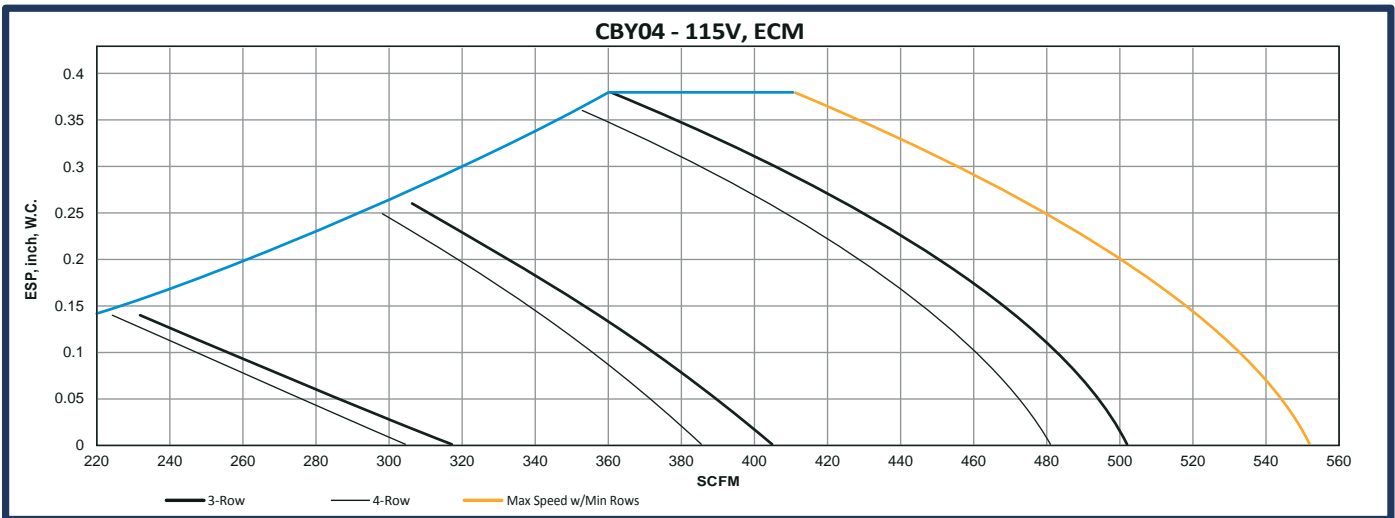
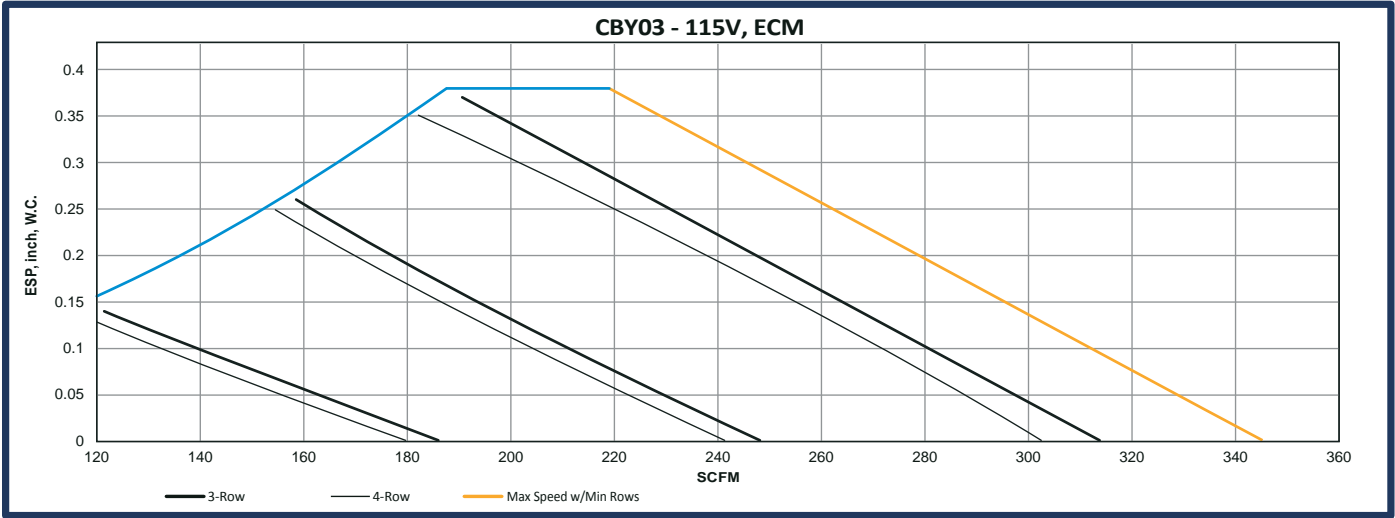

Fan Performance Curves – ECM, Cont'd.

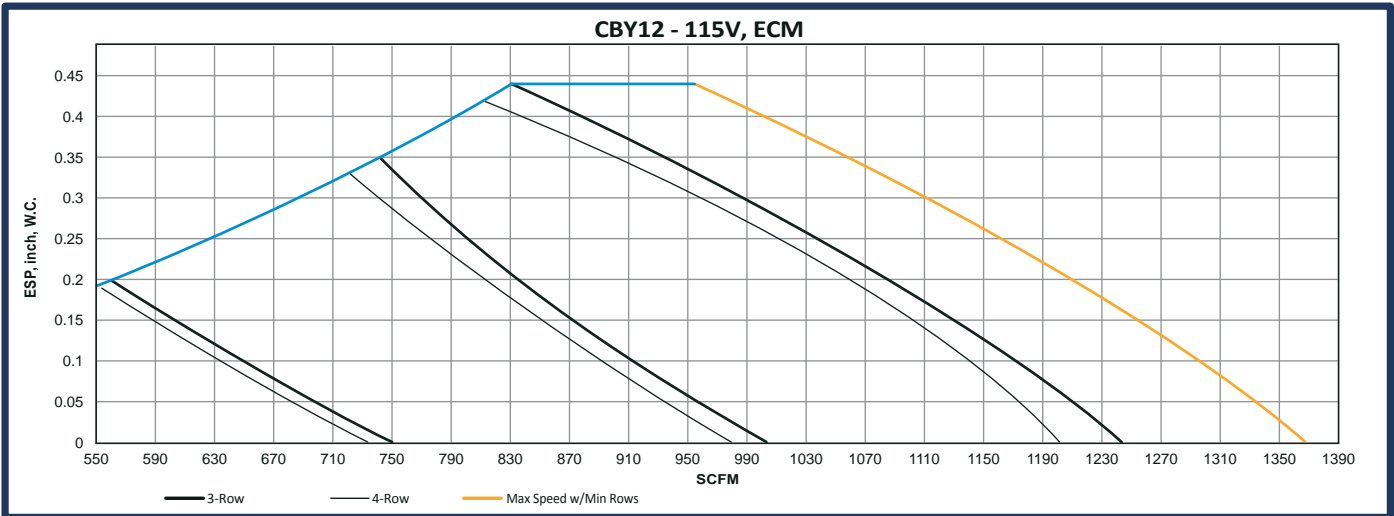
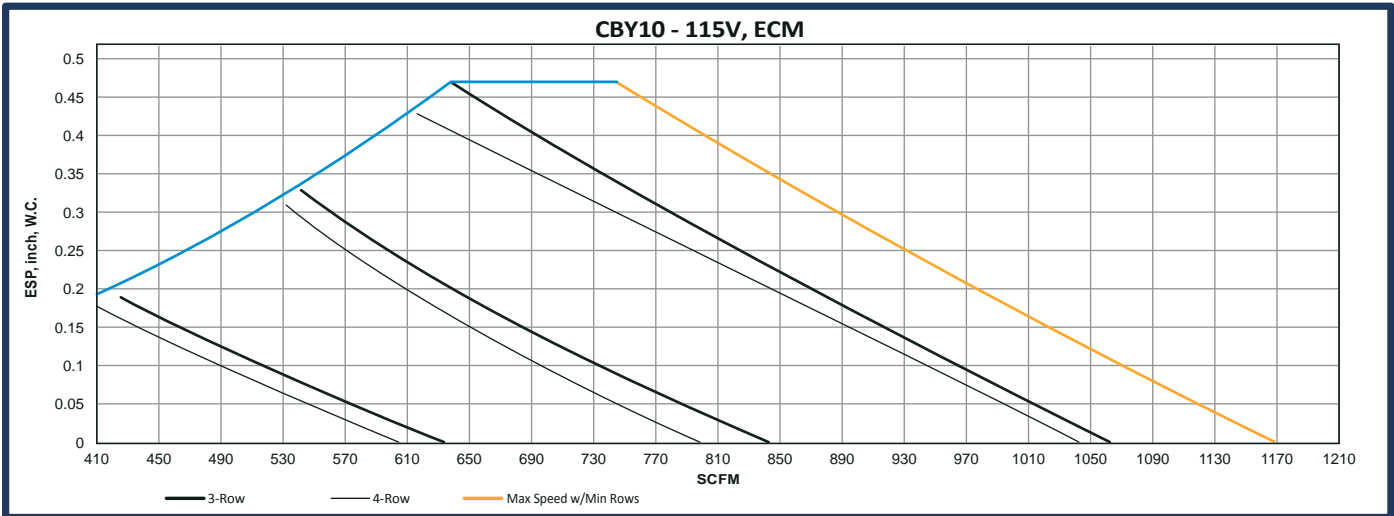
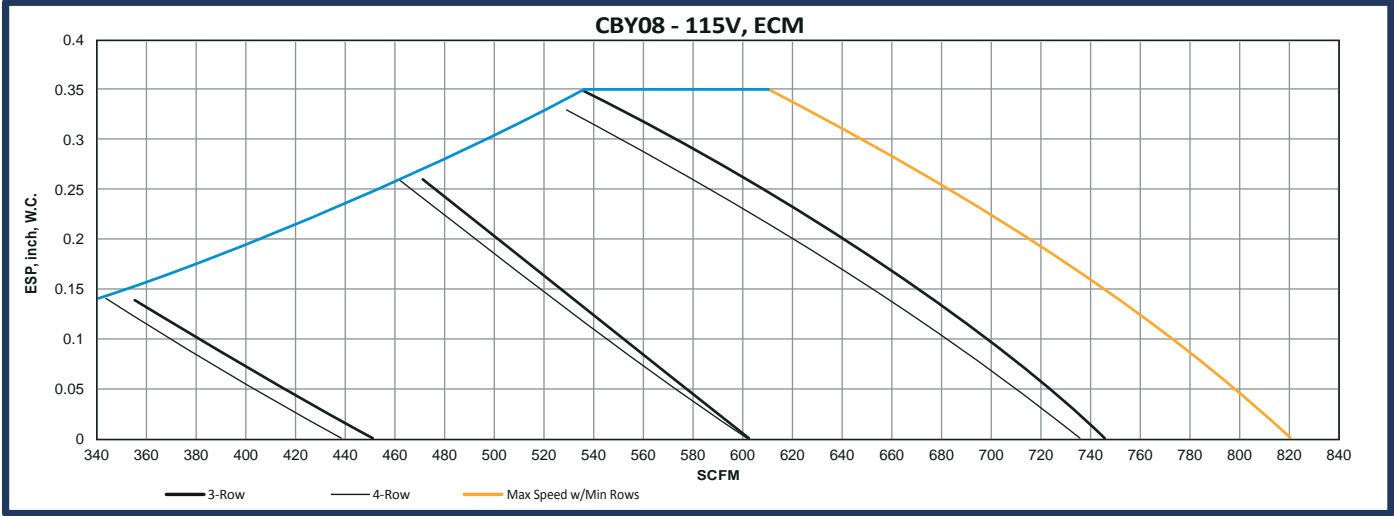

Fan Performance Curves – ECM, Cont'd.

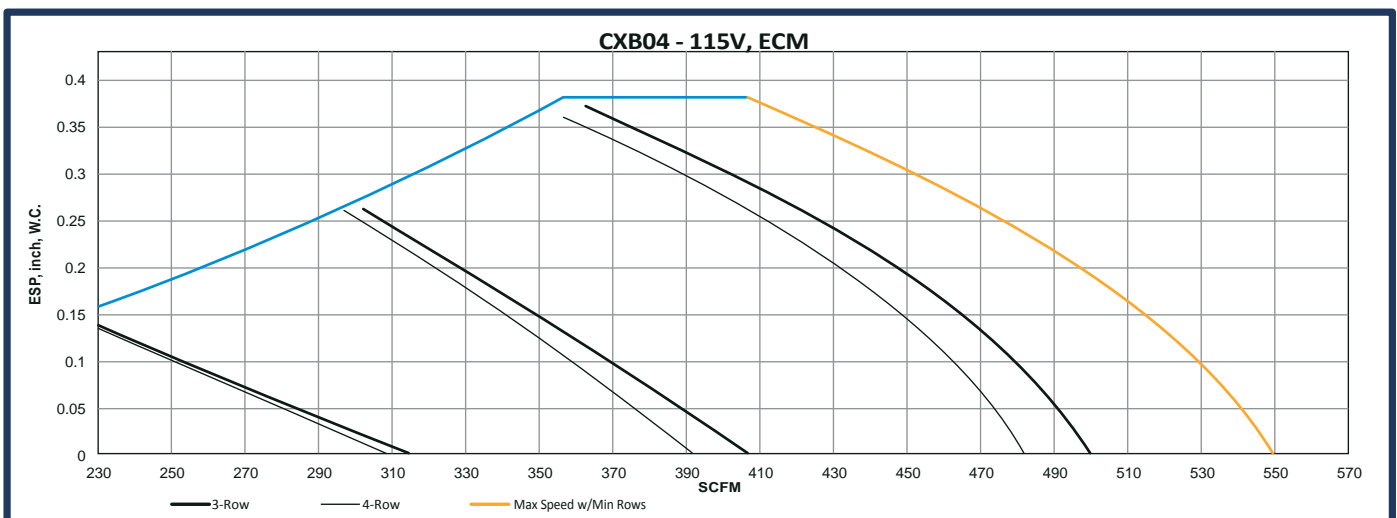
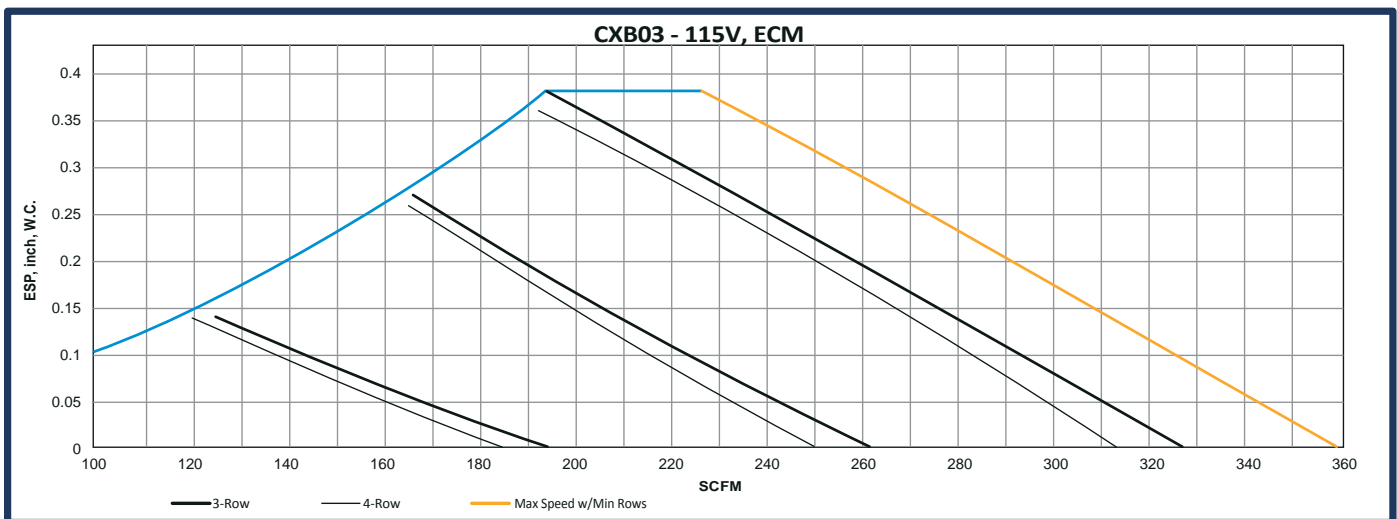
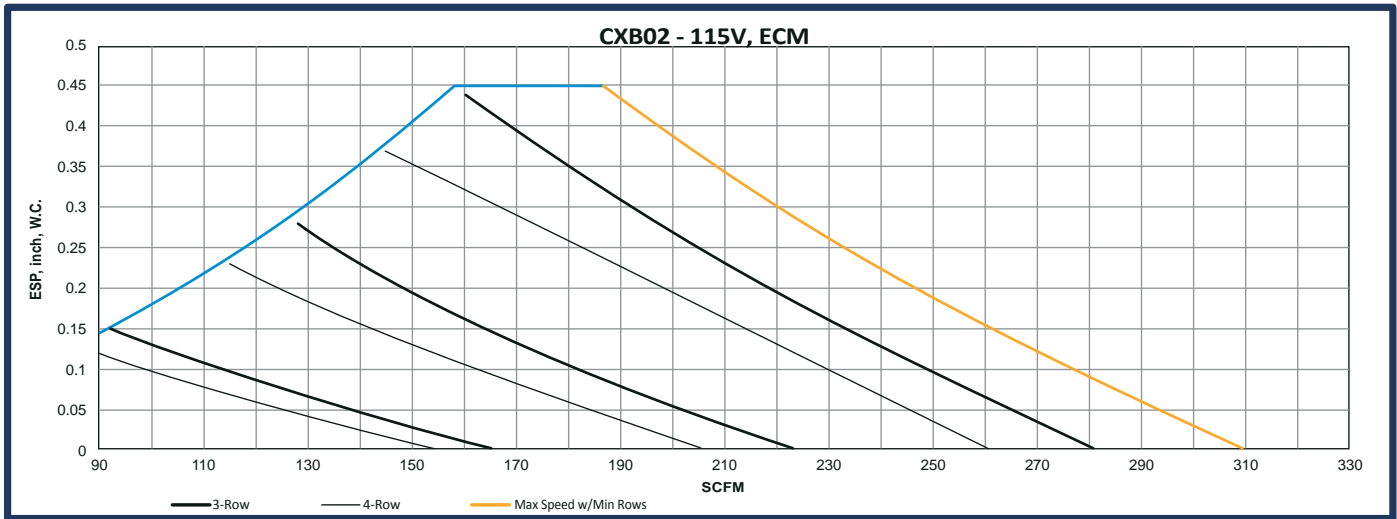

Fan Performance Curves – ECM, Cont'd.

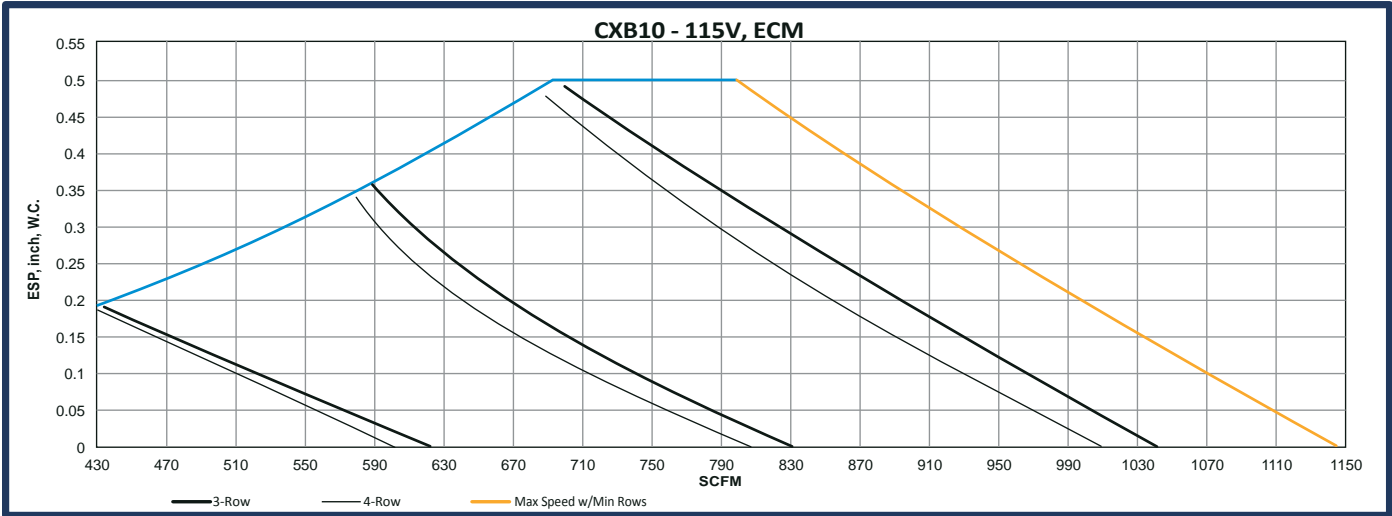
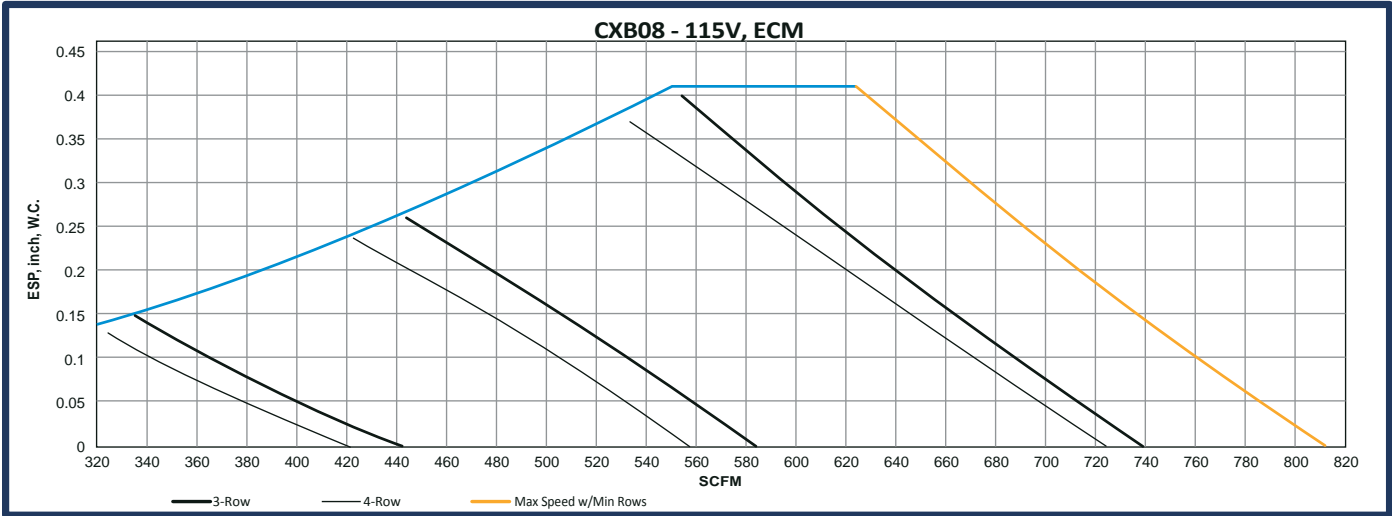
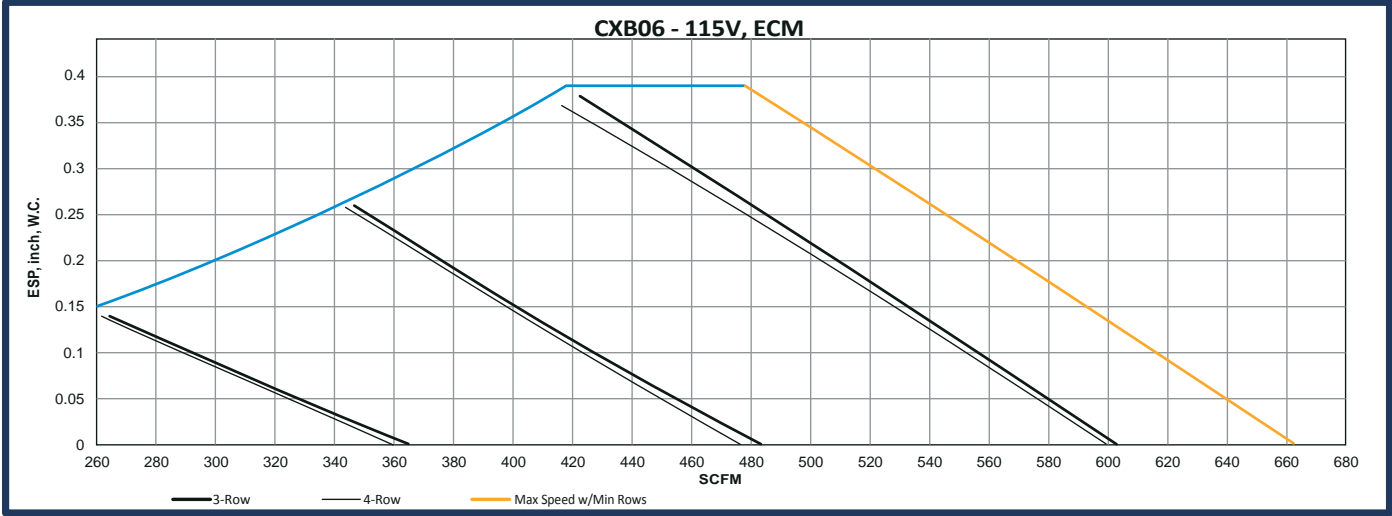

Fan Performance Curves – ECM, Cont'd.

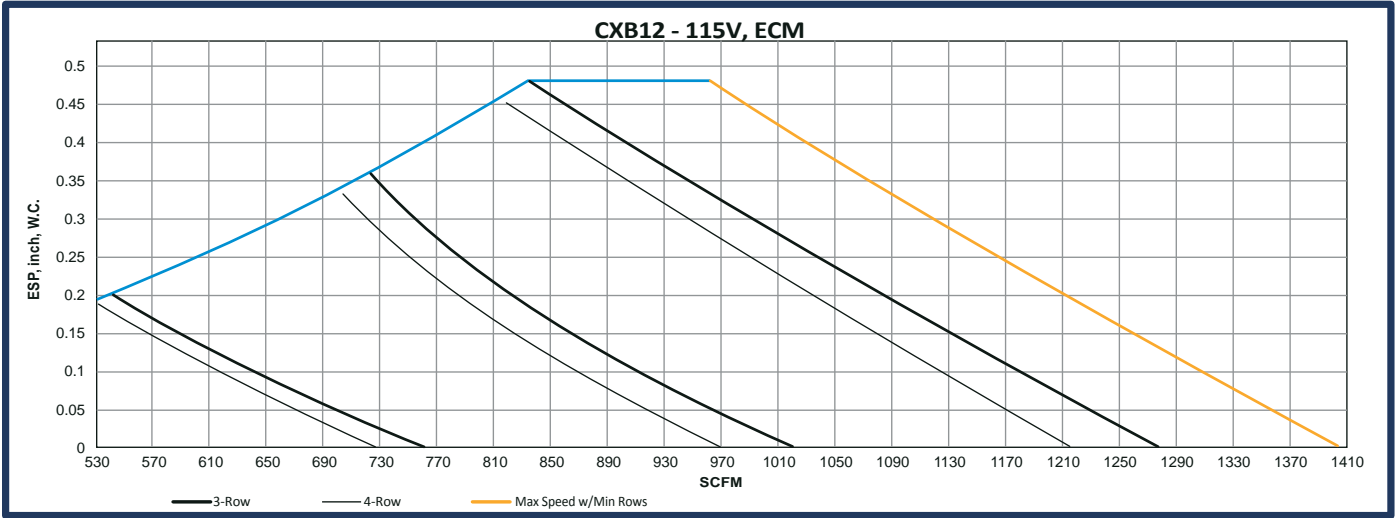

PSC – Air Delivery (60 Hz)

Model	Coil	Unit Size	CFM @ 0.0 ESP - for PSC Fan Speed			PSC High Speed CFM @ ESP Indicated						
			Low	Med	High	0.05	0.10	0.15	0.20	0.25	0.30	0.35
CHY	3 Row	02	224	295	350	329	307	285	263	241	-	-
		03	231	304	365	347	328	308	288	267	246	-
		04	298	399	653	610	571	535	502	473	447	425
		06	331	440	768	741	709	673	633	589	541	489
		08	444	756	917	884	847	808	766	721	673	622
		10	620	823	1,315	1,242	1,170	1,099	1,029	960	892	825
	4 Row	12	822	1,385	1,620	1,540	1,455	1,365	1,270	1,171	1,066	957
		02	208	278	324	299	276	254	235	217	-	-
		03	220	291	346	328	310	290	270	248	-	-
		04	281	382	603	559	519	484	454	428	406	390
		06	317	421	722	694	663	628	590	547	502	452
		08	427	714	851	821	788	752	713	672	627	580
		10	594	782	1,209	1,128	1,052	982	919	861	810	764
		12	781	1,288	1,476	1,382	1,294	1,211	1,133	1,059	991	928
CPY	3 Row	02	198	250	285	269	253	236	217	198	-	-
		03	223	298	356	343	328	311	291	269	244	-
		04	270	357	552	531	508	482	453	421	387	350
		06	287	398	693	664	632	598	562	524	484	441
		08	394	682	822	793	760	724	684	640	592	540
		10	537	701	1,008	973	931	884	829	769	702	629
	4 Row	12	747	1,202	1,367	1,325	1,274	1,214	1,145	1,066	979	883
		02	192	242	273	258	242	226	208	189	-	-
		03	216	285	337	323	308	291	271	250	-	-
		04	264	349	530	508	484	458	429	398	365	330
		06	284	386	653	628	599	568	533	496	456	412
		08	386	647	756	737	706	671	633	592	547	499
		10	525	689	985	947	904	855	801	741	675	604
		12	731	1,162	1,313	1,271	1,222	1,164	1,098	1,024	942	851
CBY	3 Row	02	191	259	307	287	266	246	226	206	-	-
		03	188	256	307	286	264	242	219	196	-	-
		04	250	334	499	484	466	443	417	386	351	313
		06	284	376	624	598	571	542	511	478	444	409
		08	372	623	726	693	659	622	584	545	504	461
		10	491	667	997	932	869	810	753	700	649	602
	4 Row	12	678	1,098	1,237	1,171	1,108	1,047	988	931	877	825
		02	186	247	290	270	250	229	209	189	-	-
		03	183	247	293	270	248	225	202	180	-	-
		04	235	315	476	460	440	417	391	361	328	292
		06	280	369	604	579	553	525	495	463	430	395
		08	366	605	707	672	636	599	561	523	484	445
		10	472	636	932	866	805	748	695	647	603	563
		12	660	1,056	1,184	1,113	1,046	983	924	869	818	771
CXB	3 Row	02	182	243	281	265	247	228	208	186	-	-
		03	201	270	323	305	284	263	240	216	-	-
		04	242	324	492	472	448	420	389	355	318	277
		06	265	354	587	564	537	507	473	435	393	347
		08	363	621	733	696	658	620	583	546	508	471
		10	486	651	998	943	888	834	779	724	670	615
	4 Row	12	672	1,125	1,275	1,203	1,133	1,063	994	926	858	792
		02	172	229	261	244	227	208	189	169	-	-
		03	195	262	311	291	271	249	227	203	-	-
		04	234	313	458	439	417	391	363	331	296	257
		06	258	344	568	544	518	488	454	418	378	335
		08	351	605	706	662	620	579	540	502	466	431
		10	467	622	929	882	834	785	735	684	631	578
		12	651	1,086	1,219	1,146	1,076	1,010	948	890	835	784

NOTES: 1. Tabled values are standard CFM at sea level, 70°F with dry coil.
 2. Rating include factory-installed filter and/or grille, where applicable.
 3. Consult factory for 50 Hz applications.

Horizontal Series

FAN COIL TECHNICAL CATALOG

ECM – Air Delivery (60 Hz)

Model	Coil	Unit Size	CFM @ 0.0 ESP - for ECM Fan Speed			ECM High Speed CFM @ ESP Indicated						
			Low	Med	High	0.05	0.10	0.15	0.20	0.25	0.30	0.35
CHY	3 Row	02	210	281	345	331	317	303	289	275	262	249
		03	210	282	361	346	330	314	297	280	263	245
		04	392	525	650	627	602	576	548	519	488	456
		06	467	604	778	751	724	696	667	638	608	577
		08	542	709	886	862	837	810	781	751	719	686
		10	795	1,058	1,322	1,267	1,213	1,160	1,108	1,058	1,008	960
	4 Row	12	961	1,296	1,612	1,557	1,503	1,449	1,395	1,342	1,289	1,236
		02	195	257	313	298	282	267	251	234	218	201
		03	198	268	342	329	314	297	277	256	233	207
		04	358	484	600	580	556	531	503	473	442	408
		06	438	576	728	704	679	653	626	598	570	540
		08	508	678	840	820	798	774	748	720	690	658
		10	729	970	1,203	1,155	1,110	1,068	1,028	990	956	923
		12	870	1,173	1,490	1,438	1,386	1,333	1,280	1,226	1,173	1,118
CPY	3 Row	02	178	235	285	276	266	255	242	229	214	199
		03	216	288	366	350	334	318	303	288	273	259
		04	333	455	558	544	528	510	490	467	442	414
		06	412	555	689	664	639	615	590	566	542	518
		08	498	662	821	799	776	751	725	697	667	636
		10	641	845	1,046	1,015	982	946	908	869	827	783
	4 Row	12	828	1,109	1,379	1,349	1,314	1,274	1,229	1,180	1,126	1,067
		02	169	226	273	265	256	244	232	218	203	186
		03	207	275	345	331	317	302	287	272	256	240
		04	316	434	534	522	507	489	469	446	420	392
		06	385	519	650	627	603	580	557	533	509	486
		08	472	629	783	765	744	721	696	668	638	606
		10	629	833	1,028	1,002	973	939	902	861	816	768
		12	797	1,065	1,319	1,293	1,262	1,224	1,181	1,131	1,076	1,014
CBY	3 Row	02	189	250	315	304	292	279	265	250	234	218
		03	187	249	314	298	281	264	247	231	214	197
		04	318	405	502	494	483	468	450	429	405	378
		06	387	494	624	601	578	556	534	513	493	473
		08	452	603	746	724	699	671	641	609	574	536
		10	636	845	1,065	1,015	965	917	871	825	781	737
	4 Row	12	751	1,004	1,244	1,210	1,172	1,131	1,087	1,040	989	935
		02	176	235	292	278	263	248	233	217	200	183
		03	180	242	303	288	272	255	238	220	201	182
		04	305	386	481	472	461	446	428	408	385	359
		06	386	485	620	594	569	546	523	502	481	462
		08	439	605	736	710	682	652	621	587	551	514
		10	606	800	1,044	993	941	888	833	776	718	658
		12	735	980	1,202	1,173	1,137	1,094	1,044	987	923	852
CXB	3 Row	02	166	224	281	265	248	233	219	205	192	180
		03	195	262	327	310	293	276	258	241	223	205
		04	315	407	500	491	479	464	446	425	401	374
		06	365	484	603	580	557	533	510	486	462	437
		08	443	584	739	713	688	664	640	617	595	574
		10	622	833	1,042	1,004	967	930	894	859	824	791
	4 Row	12	761	1,019	1,277	1,227	1,179	1,131	1,084	1,037	991	946
		02	156	206	262	246	230	214	198	183	167	151
		03	186	250	313	298	283	266	250	232	214	196
		04	309	392	482	474	463	449	431	411	388	362
		06	361	477	600	577	553	528	504	478	453	427
		08	421	557	724	698	672	646	621	595	569	544
		10	602	809	1,011	968	928	890	854	820	788	758
		12	727	969	1,217	1,170	1,124	1,078	1,033	989	945	902

- NOTES: 1. Tabled values are standard CFM at sea level, 70°F with dry coil.
 2. Rating include factory-installed filter and/or grille, where applicable.
 3. Consult factory for 50 Hz applications.

Motor Data

Thermal Overload Protection and ETL Listing

All permanently lubricated split-capacitor motors furnished by IEC contain internal thermal-overload protection. The overload automatically resets when the temperature returns to a safe limit. Electronics Testing Laboratories, Inc. approves the motor and thermal overload combination at locked rotor conditions only.

PSC Motor Performance Data — CHY, CPY, CXB, CBY

Voltage	Fan Speed	Unit Size	02	03	04	06	08	10	12
		Nominal HP	1/30	1/30	1/12	1/12	1/6	(2) 1/12	(2) 1/6
115V 60 Hz 1 Phase	High	Amps	0.53	0.83	1.40	1.40	2.50	2.80	5.00
		Watts	78	89	144	151	223	286	399
208V 60 Hz 1 Phase	High	Amps	0.48	0.48	0.69	0.69	1.30	1.38	2.60
		Watts	98	99	120	132	189	245	325
230V 60 Hz 1 Phase	High	Amps	0.48	0.48	0.69	0.69	1.30	1.38	2.60
		Watts	114	112	137	150	206	281	356
277V 60 Hz 1 Phase	High	Amps	0.35	0.35	0.69	0.69	0.91	1.38	1.82
		Watts	104	112	143	155	245	288	426

NOTES: 1. Total unit motor Amps and Watts are shown.
2. Consult factory for 50 Hz applications.

EC Motor Performance Data — CHY, CPY, CXB, CBY

Voltage	Unit Size	02	03	04	06	08	10	12
	Nominal HP	1/7	1/7	1/6	1/6	1/6	(2) 1/6	(2) 1/6
120V	Rated Motor FLA	2.3	2.3	2.4	2.4	2.4	(2) 2.4	(2) 2.4
	Max Program Current	1.3	1.5	2.1	1.9	2.4	2.0, 2.0	2.4, 2.4
208-240V	Rated Motor FLA	1.4	1.4	1.6	1.6	1.6	1.6, 1.6	1.6, 1.6
	Max Program Current	0.8	0.9	1.4	1.3	1.6	1.3, 1.3	1.6, 1.6
277V	Rated Motor FLA	1.2	1.2	1.3	1.3	1.3	1.3, 1.3	1.3, 1.3
	Max Program Current	0.7	0.8	1.1	1	1.3	1.1, 1.1	1.3, 1.3

Sound Data

CBY Sound Power Data

UNIT SIZE	RATING	FAN SPEED	CFM	SOUND POWER LEVEL, Lw (dB reference one picowatt)							A-wgt (dBA)
				125 Hz	250 Hz	500 Hz	1K Hz	2K Hz	4K Hz	8K Hz	
2	CASING RADIATED	H	270	60	54	51	48	43	38	37	53
		M	170	55	51	44	39	35	31	34	47
		L	135	53	49	39	34	29	29	34	44
	DUCTED DISCHARGE	H	270	52	52	53	47	46	40	37	54
		M	170	47	45	45	39	37	31	34	46
		L	135	46	43	40	33	31	29	34	42
3	CASING RADIATED	H	290	63	54	52	49	44	40	38	54
		M	205	59	47	44	40	35	31	34	47
		L	155	55	42	39	34	29	29	34	43
	DUCTED DISCHARGE	H	290	59	54	54	51	47	41	38	56
		M	205	55	46	47	41	37	31	34	48
		L	155	51	42	42	35	31	29	34	43
4	CASING RADIATED	H	540	70	58	55	52	48	43	39	58
		M	360	62	49	46	42	37	32	34	50
		L	250	54	42	38	32	30	30	34	42
	DUCTED DISCHARGE	H	540	64	57	59	55	50	44	39	60
		M	360	55	49	51	52	46	36	36	50
		L	250	48	42	43	35	30	28	33	43
6	CASING RADIATED	H	680	65	59	57	52	48	45	42	59
		M	445	57	50	47	41	37	33	34	49
		L	330	52	43	40	34	29	29	34	43
	DUCTED DISCHARGE	H	680	63	58	59	56	50	46	42	60
		M	445	57	49	50	45	39	33	34	50
		L	330	53	43	42	37	30	29	34	44
8	CASING RADIATED	H	765	65	61	58	54	51	48	45	60
		M	670	63	58	55	51	47	44	41	57
		L	410	55	47	44	38	34	31	34	46
	DUCTED DISCHARGE	H	765	63	61	61	58	53	50	46	63
		M	670	60	58	58	54	50	46	42	59
		L	410	52	47	47	41	36	32	35	48
10	CASING RADIATED	H	1105	68	64	59	55	52	48	45	62
		M	730	64	55	51	45	41	37	35	54
		L	490	59	48	43	36	31	30	34	47
	DUCTED DISCHARGE	H	1105	65	62	64	60	55	50	46	65
		M	730	63	54	56	50	44	38	36	56
		L	490	58	46	47	40	33	30	34	48
12	CASING RADIATED	H	1225	68	65	61	57	53	50	45	63
		M	1140	67	63	59	54	51	47	42	61
		L	745	59	54	50	44	40	35	34	52
	DUCTED DISCHARGE	H	1225	65	63	65	60	57	52	47	66
		M	1140	63	61	63	58	54	50	44	64
		L	745	56	54	55	48	43	37	35	54

NOTES: 1. Unit Test Configuration: Bottom Return/ Front Supply, 3 Row 10 FPI Coil, 0.0" ESP @ High Speed, 115VAC PSC Motor, 1/2" dual density fiberglass insulation.
 2. Casing Radiated tested in accordance with AHRI 260-2001: 4.2.2.3 Casing radiated with free inlet, Sound Rating of Ducted Air Moving and Conditioning Equipment.
 3. Ducted Discharge tested in accordance with AHRI 260-2001: 4.2.2.1 Ducted discharge, Sound Rating of Ducted Air Moving and Conditioning Equipment.
 4. Sound power data is expressed in decibels, dB RE: 1×10^{-12} w (picowatts).

Sound Data, Cont'd.

CHY Sound Power Data

UNIT SIZE	RATING	FAN SPEED	CFM	SOUND POWER LEVEL, Lw (dB reference one picowatt)						A-wgt (dBA)	
				125 Hz	250 Hz	500 Hz	1K Hz	2K Hz	4K Hz		8K Hz
2	CASING RADIATED	H	280	58	56	57	56	52	48	43	60
		M	200	52	50	51	49	44	38	37	53
		L	165	48	45	45	43	37	33	37	47
	DUCTED DISCHARGE	H	280	56	53	52	48	45	38	38	54
		M	200	51	47	46	41	37	32	36	47
		L	165	48	43	41	35	31	30	36	43
3	CASING RADIATED	H	300	58	55	58	57	54	49	44	61
		M	210	52	47	49	47	42	37	37	51
		L	165	50	43	43	41	36	32	36	46
	DUCTED DISCHARGE	H	300	55	52	53	50	47	40	38	55
		M	210	50	46	47	42	38	32	35	48
		L	165	48	42	41	36	32	30	35	43
4	CASING RADIATED	H	625	64	62	63	62	60	56	52	67
		M	415	58	53	54	52	47	42	39	56
		L	315	53	46	47	44	38	33	37	48
	DUCTED DISCHARGE	H	625	67	57	59	57	52	46	43	61
		M	415	62	48	49	45	40	33	36	51
		L	315	57	43	42	37	31	30	36	45
6	CASING RADIATED	H	750	67	63	63	62	59	55	52	66
		M	460	59	51	52	49	45	40	38	54
		L	350	54	44	43	41	36	32	36	46
	DUCTED DISCHARGE	H	750	67	63	63	62	59	55	52	66
		M	460	59	51	52	49	45	40	38	54
		L	350	54	44	43	41	36	32	36	46
8	CASING RADIATED	H	875	65	66	67	66	63	60	57	71
		M	720	62	61	62	61	57	54	50	65
		L	425	53	48	49	46	41	36	36	51
	DUCTED DISCHARGE	H	875	73	62	63	62	57	54	51	66
		M	720	72	59	59	57	52	48	45	62
		L	425	63	45	46	41	35	32	35	50
10	CASING RADIATED	H	1220	67	67	67	67	63	60	56	71
		M	840	62	57	59	56	51	47	42	60
		L	645	58	51	52	48	42	37	36	53
	DUCTED DISCHARGE	H	1220	68	62	64	62	56	52	49	66
		M	840	65	54	55	51	44	39	37	56
		L	645	62	47	48	43	36	31	34	50
12	CASING RADIATED	H	1525	68	68	69	69	65	62	59	73
		M	1330	65	65	66	65	61	57	54	69
		L	820	56	53	55	51	46	41	38	56
	DUCTED DISCHARGE	H	1525	68	64	66	64	59	56	52	68
		M	1330	65	61	63	60	55	51	48	65
		L	820	56	49	52	46	40	35	35	52

- NOTES: 1. Unit Test Configuration: Bottom Return/ Front Supply, 3 Row 10 FPI Coil, 0.0" ESP @ High Speed, 115VAC PSC Motor, 1/2" dual density fiberglass insulation.
2. Casing Radiated tested in accordance with AHRI 260-2001: 4.2.2.3 Casing radiated with free inlet, Sound Rating of Ducted Air Moving and Conditioning Equipment.
3. Ducted Discharge tested in accordance with AHRI 260-2001: 4.2.2.1 Ducted discharge, Sound Rating of Ducted Air Moving and Conditioning Equipment.
4. Sound power data is expressed in decibels, dB RE: 1×10^{-12} w (picowatts).

Horizontal Series

FAN COIL TECHNICAL CATALOG

Sound Data, Cont'd.

CPY Sound Power Data

UNIT SIZE	RATING	FAN SPEED	CFM	SOUND POWER LEVEL, Lw (dB reference one picowatt)							A-wgt (dBA)
				125 Hz	250 Hz	500 Hz	1K Hz	2K Hz	4K Hz	8K Hz	
2	CASING RADIATED	H	250	59	57	57	51	46	40	38	57
		M	170	57	53	52	45	40	35	37	52
		L	135	55	49	48	40	34	31	36	48
	DUCTED DISCHARGE	H	250	60	53	53	48	45	39	37	54
		M	170	57	48	48	43	40	33	36	49
		L	135	54	44	43	37	34	30	36	45
3	CASING RADIATED	H	285	57	58	58	50	47	43	39	58
		M	195	50	50	50	41	37	33	36	49
		L	140	46	45	44	35	30	31	36	44
	DUCTED DISCHARGE	H	285	56	51	52	49	46	40	37	54
		M	195	52	46	46	42	39	33	35	48
		L	140	49	41	41	37	32	30	35	43
4	CASING RADIATED	H	510	65	64	63	58	53	48	44	64
		M	360	62	57	56	50	44	38	37	56
		L	265	59	50	49	43	36	32	37	50
	DUCTED DISCHARGE	H	510	68	59	61	58	54	47	43	63
		M	360	64	51	53	49	44	37	37	55
		L	265	60	45	47	42	36	31	36	49
6	CASING RADIATED	H	660	65	64	62	57	52	48	44	63
		M	410	58	53	53	45	39	34	36	53
		L	310	53	47	45	37	31	31	36	46
	DUCTED DISCHARGE	H	660	66	59	60	57	52	48	44	62
		M	410	58	48	49	45	39	34	36	51
		L	310	53	42	42	37	30	30	36	44
8	CASING RADIATED	H	770	66	68	65	59	56	53	50	66
		M	650	64	65	62	55	51	48	44	63
		L	390	57	51	50	42	36	32	35	50
	DUCTED DISCHARGE	H	770	68	63	63	62	57	54	50	66
		M	650	67	59	59	57	52	49	44	62
		L	390	61	46	46	42	36	32	35	49
10	CASING RADIATED	H	995	67	70	66	61	56	51	46	67
		M	700	65	61	59	52	46	41	37	59
		L	540	62	53	53	44	38	32	35	53
	DUCTED DISCHARGE	H	995	70	63	64	62	56	52	47	66
		M	700	71	55	57	53	47	41	36	59
		L	540	68	49	51	45	39	33	34	54
12	CASING RADIATED	H	1305	67	70	69	63	58	55	51	69
		M	1145	65	68	66	60	55	52	47	66
		L	700	56	55	55	47	41	36	36	55
	DUCTED DISCHARGE	H	1305	67	65	66	64	59	56	51	68
		M	1145	64	62	63	61	56	52	47	65
		L	700	55	50	53	48	42	36	35	53

- NOTES: 1. Unit Test Configuration: Bottom Return/ Front Supply, 3 Row 10 FPI Coil, 0.0" ESP @ High Speed, 115VAC PSC Motor, 1/2" dual density fiberglass insulation.
2. Casing Radiated tested in accordance with AHRI 260-2001: 4.2.2.3 Casing radiated with free inlet, Sound Rating of Ducted Air Moving and Conditioning Equipment.
3. Ducted Discharge tested in accordance with AHRI 260-2001: 4.2.2.1 Ducted discharge, Sound Rating of Ducted Air Moving and Conditioning Equipment.
4. Sound power data is expressed in decibels, dB RE: 1×10^{-12} w (picowatts).

Sound Data, Cont'd.

CXB Sound Power Data

UNIT SIZE	RATING	FAN SPEED	CFM	SOUND POWER LEVEL, L _w (dB reference one picowatt)							A-wgt (dBA)
				125 Hz	250 Hz	500 Hz	1K Hz	2K Hz	4K Hz	8K Hz	
2	CASING RADIATED	H	220	60	58	56	54	49	44	39	59
		M	160	54	51	49	45	39	33	31	50
		L	130	50	46	44	39	33	26	31	45
3	CASING RADIATED	H	265	61	58	57	54	49	45	41	59
		M	185	54	50	49	44	40	33	32	50
		L	135	52	45	44	39	33	27	31	45
4	CASING RADIATED	H	480	68	63	63	60	55	50	44	65
		M	310	64	53	54	48	42	35	32	55
		L	205	58	46	45	38	31	26	31	47
6	CASING RADIATED	H	605	67	64	63	59	54	51	45	64
		M	385	59	54	53	46	41	34	32	53
		L	280	55	48	46	39	31	26	31	47
8	CASING RADIATED	H	690	67	67	66	62	58	55	51	67
		M	600	66	64	62	58	54	50	46	64
		L	355	57	52	51	45	39	33	32	51
10	CASING RADIATED	H	925	69	68	68	66	60	55	50	70
		M	620	64	58	60	55	48	42	34	60
		L	415	59	51	52	44	37	29	31	52
12	CASING RADIATED	H	1180	70	70	69	66	61	58	53	71
		M	1060	70	68	67	63	58	54	49	68
		L	665	64	57	57	50	44	38	32	57

- NOTES: 1. Unit Test Configuration: Bottom Return/ Front Supply, 3 Row 10 FPI Coil, 0.0" ESP @ High Speed, 115VAC PSC Motor, 1/2" dual density fiberglass insulation.
 2. Casing Radiated tested in accordance with AHRI 260-2001: 4.2.2.3 Casing radiated with free inlet, Sound Rating of Ducted Air Moving and Conditioning Equipment.
 3. Ducted Discharge tested in accordance with AHRI 260-2001: 4.2.2.1 Ducted discharge, Sound Rating of Ducted Air Moving and Conditioning Equipment.
 4. Sound power data is expressed in decibels, dB RE: 1 x 10⁻¹² w (picowatts).

Electric Heating

Electric Resistance Heating

Electric heaters are available on IEC Horizontal Series fan coil units for the following applications.

Total Electric Heat

Total electric heat eliminates the requirement for a boiler. Heating and/or cooling may be available on an individual basis throughout the year. Two-pipe chilled water is used for cooling; and the electric heater is used for heating. Individual room controls can be supplied for either manual or automatic changeover.

Auxiliary Electric Heat

Auxiliary electric heat is ideal for tempering room air between seasons and during the cooling season when chilled water is being circulated. Individual room controls are supplied to provide electric heat only when chilled water is being circulated. During regular heating season, heating is provided by hot water being circulated in the system.

Construction

The heater coils of high-grade resistance wire are supported by ceramic insulators on plated steel brackets. These heat elements are suspended directly in front of the fan outlet between the blower and the coil. High limit thermal cutouts protect the heater in the event of air failure. There are many special applications and control sequences for electric heat. For special applications, please consult the factory.

Electric Heater Selection

Voltage	kW	Unit Size						
		02	03	04	06	08	10	12
120V	0.5	•	•	-	-	-	-	-
	1.0	•	•	•	•	•	-	-
	1.5	•	•	•	•	•	-	-
	2.0	•	•	•	•	•	•	•
	3.0	-	•	•	•	•	•	•
208V	0.5	•	•	-	-	-	-	-
	1.0	•	•	•	•	•	-	-
	1.5	•	•	•	•	•	-	-
	2.0	•	•	•	•	•	•	•
	3.0	-	•	•	•	•	•	•
	4.0	-	-	-	•	•	•	•
	5.0	-	-	-	• Note 5	•	•	•
	6.0	-	-	-	• Note 5	• Note 5	•	•
8.0	-	-	-	-	-	• Note 5	• Note 5	
240V 277V	0.5	•	•	-	-	-	-	-
	1.0	•	•	•	•	•	-	-
	1.5	•	•	•	•	•	-	-
	2.0	•	•	•	•	•	•	•
	3.0	-	•	•	•	•	•	•
	4.0	-	-	-	•	•	•	•
	5.0	-	-	-	• Note 5	•	•	•
	6.0	-	-	-	• Note 5	• Note 5	•	•
	8.0	-	-	-	-	-	• Note 5	• Note 5
	10.0	-	-	-	-	-	-	• Note 5

- NOTES: 1. All heaters are single stage and single phase.
 2. Heaters over 48 Amps are subdivided and fused.
 3. Electric Heating Capacities (BTUH) = Heater kW x 3413.
 4. Consult factory for 50 Hz applications.
 5. High and medium speed only.

Submittal Data

CHY – Horizontal Hideaway

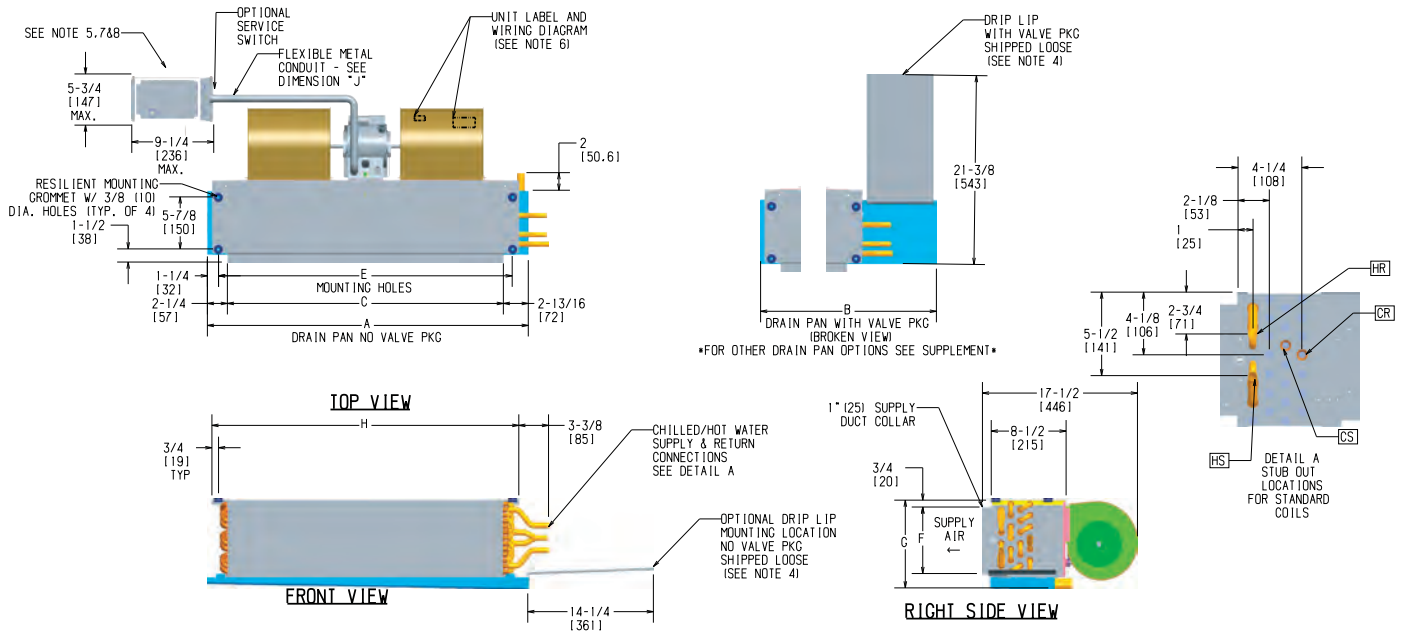

Unit Model	Dimensions - Inches (Millimeters)									Quantity/Unit		Unit Weight*
	A	B	C	E	F	G	H	J	Blower	Motor		
CHY02	21-1/4 (540)	28-1/2 (724)	16 (406)	18-1/4 (464)	6-1/4 (159)	8-3/4 (222)	19-3/4 (502)	38 (965)	1	1	36	
CHY03	25-1/4 (641)	32-1/2 (826)	20 (508)	22-1/4 (565)	6-1/4 (159)	8-3/4 (222)	23-3/4 (603)	38 (965)	1	1	39	
CHY04	31-1/4 (794)	38-1/2 (978)	26 (660)	28-1/4 (718)	6-1/4 (159)	8-3/4 (222)	29-3/4 (756)	38 (965)	2	1	49	
CHY06	36-1/4 (921)	43-1/5 (1105)	31 (787)	33-1/4 (845)	7-1/2 (191)	10 (254)	34-3/4 (883)	38 (965)	2	1	59	
CHY08	43-1/4 (1099)	50-1/2 (1283)	38 (965)	40-1/4 (1022)	7-1/2 (191)	10 (254)	41-3/4 (1060)	38 (965)	2	1	64	
CHY10	57-1/4 (1454)	64-1/2 (1638)	52 (1321)	54-1/4 (1378)	7-1/2 (191)	10 (254)	55-3/4 (1416)	60 (1524)	4	2	95	
CHY12	65-1/4 (1657)	72-1/2 (1842)	60 (1524)	62-1/4 (1581)	7-1/2 (191)	10 (254)	63-3/4 (1619)	65 (1651)	4	2	107	

NOTES: * Unit weights (shown in pounds) are based on dry coils, minimum rows and exclude packaging, valves or other components.

1. RH shown, LH opposite.
2. All dimensions are +/- .25 (6). Drawing not to scale.
3. Product specifications are subject to change without notice.
4. Drip lip recommended. Provided when valve PKG is ordered.
5. Control box size and position may vary (consult factory).
6. Position may vary.
7. Service access is located on the front of the control box.
8. Knockouts on the bottom and side of the control box for incoming power connections.
9. Typical size 06 unit shown with 1-Motor and 2-BLWR - Refer to table for variation.
10. See Valve Package Supplemental for piping termination.

Drawing is provided for reference only.
Dimensions may vary with options ordered.
Consult IEC website for submittal drawings.

Horizontal Series

FAN COIL TECHNICAL CATALOG

Submittal Data, Cont'd.

CHY – Horizontal Hideaway with Electric Heat

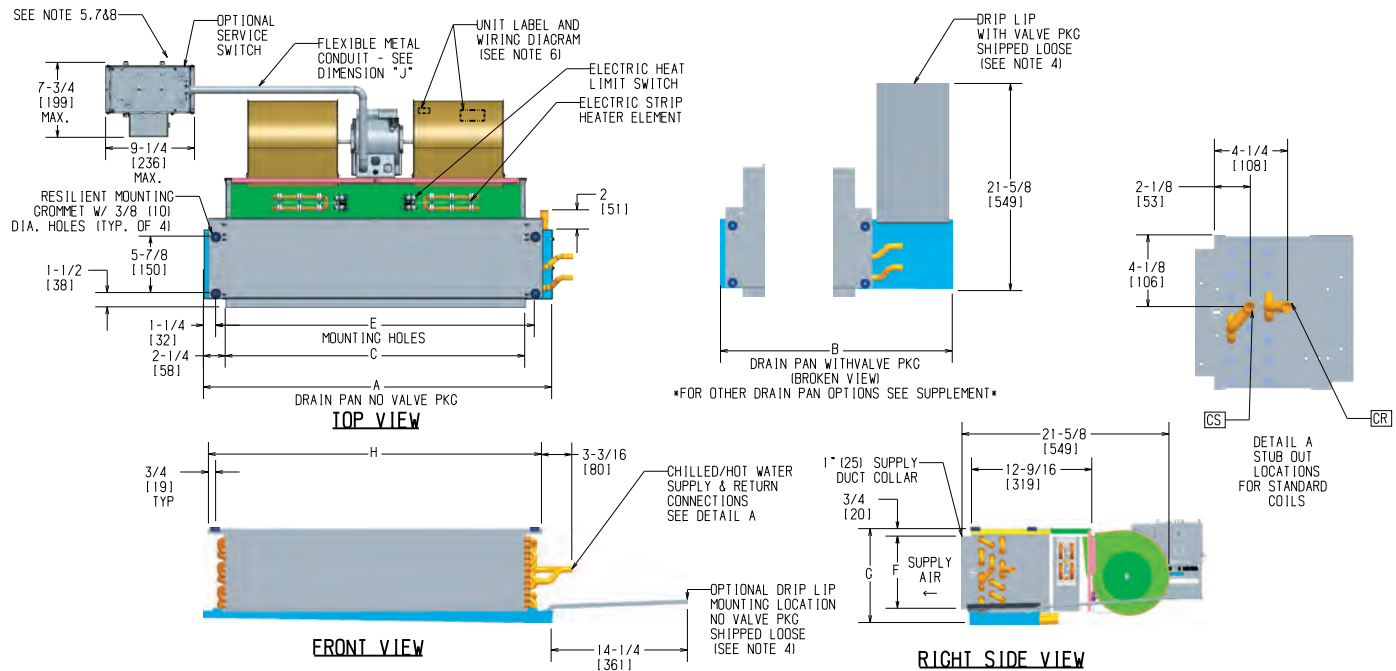

Unit Model	Dimensions - Inches (Millimeters)								Quantity/Unit		Unit Weight*
	A	B	C	E	F	G	H	J	Blower	Motor	
CHY02	21-1/4 (540)	28-1/2 (724)	16 (406)	18-1/4 (464)	6-1/4 (159)	8-3/4 (222)	19-3/4 (502)	38 (965)	1	1	38
CHY03	25-1/4 (641)	32-1/2 (826)	20 (508)	22-1/4 (565)	6-1/4 (159)	8-3/4 (222)	23-3/4 (603)	38 (965)	1	1	41
CHY04	31-1/4 (794)	38-1/2 (978)	26 (660)	28-1/4 (718)	6-1/4 (159)	8-3/4 (222)	29-3/4 (756)	38 (965)	2	1	51
CHY06	36-1/4 (921)	43-1/5 (1105)	31 (787)	33-1/4 (845)	7-1/2 (191)	10 (254)	34-3/4 (883)	38 (965)	2	1	61
CHY08	43-1/4 (1099)	50-1/2 (1283)	38 (965)	40-1/4 (1022)	7-1/2 (191)	10 (254)	41-3/4 (1060)	38 (965)	2	1	66
CHY10	57-1/4 (1454)	64-1/2 (1638)	52 (1321)	54-1/4 (1378)	7-1/2 (191)	10 (254)	55-3/4 (1416)	60 (1524)	4	2	97
CHY12	65-1/4 (1657)	72-1/2 (1842)	60 (1524)	62-1/4 (1581)	7-1/2 (191)	10 (254)	63-3/4 (1619)	65 (1651)	4	2	109

NOTES: * Unit weights (shown in pounds) are based on dry coils, minimum rows and exclude packaging, valves or other components.

1. RH shown, LH opposite.
2. All dimensions are +/- .25 (6). Drawing not to scale.
3. Product specifications are subject to change without notice.
4. Drip lip recommended. Provided when valve PKG is ordered.
5. Control box size and position may vary (consult factory).
6. Position may vary.
7. Service entrance is located on the rear of the control box with knockouts.
8. Units without service switch use the knockouts on the rear side of the control box.
9. Typical size 06 unit shown with 1-Motor and 2-BLWR - Refer to table for variation.
10. See Valve Package Supplemental for piping termination.

Drawing is provided for reference only.
 Dimensions may vary with options ordered.
 Consult IEC website for submittal drawings.

Submittal Data, Cont'd.

CPY – Horizontal Hideaway with Plenum

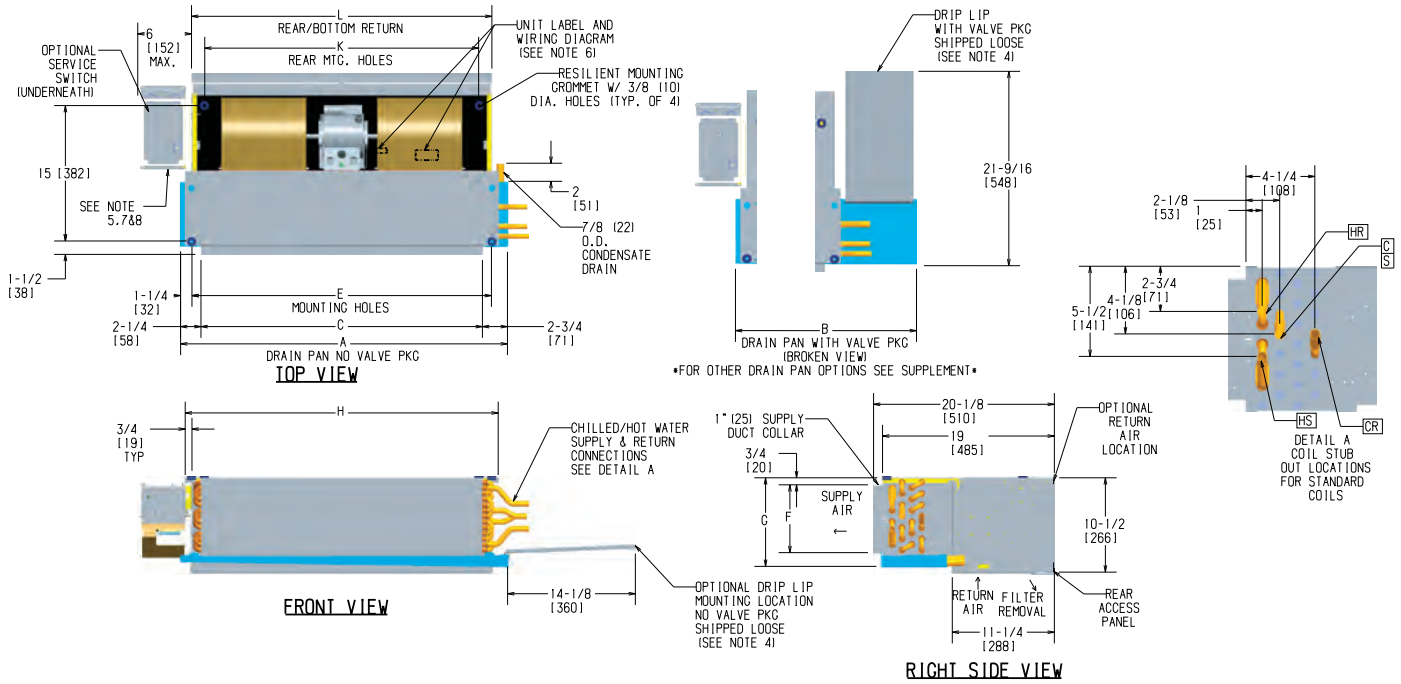

Unit Model	Dimensions - Inches (Millimeters)									Quantity/Unit		Unit Weight*
	A	B	C	E	F	G	H	K	L	Blower	Motor	
CPY02	21-1/4 (540)	28-1/2 (724)	16 (406)	18-1/4 (464)	6-1/4 (159)	8-3/4 (222)	19-3/4 (502)	15-3/8 (391)	18-1/4 (464)	1	1	55
CPY03	25-1/4 (641)	32-1/2 (826)	20 (508)	22-1/4 (565)	6-1/4 (159)	8-3/4 (222)	23-3/4 (603)	19-3/8 (493)	22-1/4 (565)	1	1	60
CPY04	31-1/4 (794)	38-1/2 (978)	26 (660)	28-1/4 (718)	6-1/4 (159)	8-3/4 (222)	29-3/4 (756)	25-3/8 (654)	28-1/4 (718)	2	1	70
CPY06	36-1/4 (921)	43-1/2 (1105)	31 (787)	33-1/4 (845)	7-1/2 (191)	10 (254)	34-3/4 (883)	30-3/8 (772)	33-1/4 (845)	2	1	82
CPY08	43-1/4 (1099)	50-1/2 (1283)	38 (965)	40-1/4 (1022)	7-1/2 (191)	10 (254)	41-3/4 (1060)	37-3/8 (950)	40-1/4 (1022)	2	1	95
CPY10	57-1/4 (1454)	64-1/2 (1638)	52 (1321)	54-1/4 (1378)	7-1/2 (191)	10 (254)	55-3/4 (1416)	51-3/8 (1306)	54-1/4 (1378)	4	2	135
CPY12	65-1/4 (1657)	72-1/2 (1842)	60 (1524)	62-1/4 (1581)	7-1/2 (191)	10 (254)	63-3/4 (1619)	59-3/8 (1509)	62-1/4 (1581)	4	2	154

NOTES: * Unit weights (shown in pounds) are based on dry coils, minimum rows and exclude packaging, valves or other components.

1. RH shown, LH opposite.
2. All dimensions are +/- .25 (6). Drawing not to scale.
3. Product specifications are subject to change without notice.
4. Drip lip recommended. Provided when valve PKG is ordered.
5. Control box size and position may vary (consult factory).
6. Position may vary.
7. Service access is located on the bottom of the control box.
8. Knockouts on the bottom and side of the control box for incoming power connections.
9. Typical size 06 unit shown with 1-Motor and 2-BLWR - Refer to table for variation.
10. See Valve Package Supplemental for piping termination.

Drawing is provided for reference only.
Dimensions may vary with options ordered.
Consult IEC website for submittal drawings.

Submittal Data, Cont'd.

CPY – Horizontal Hideaway with Plenum and Side Filter Access

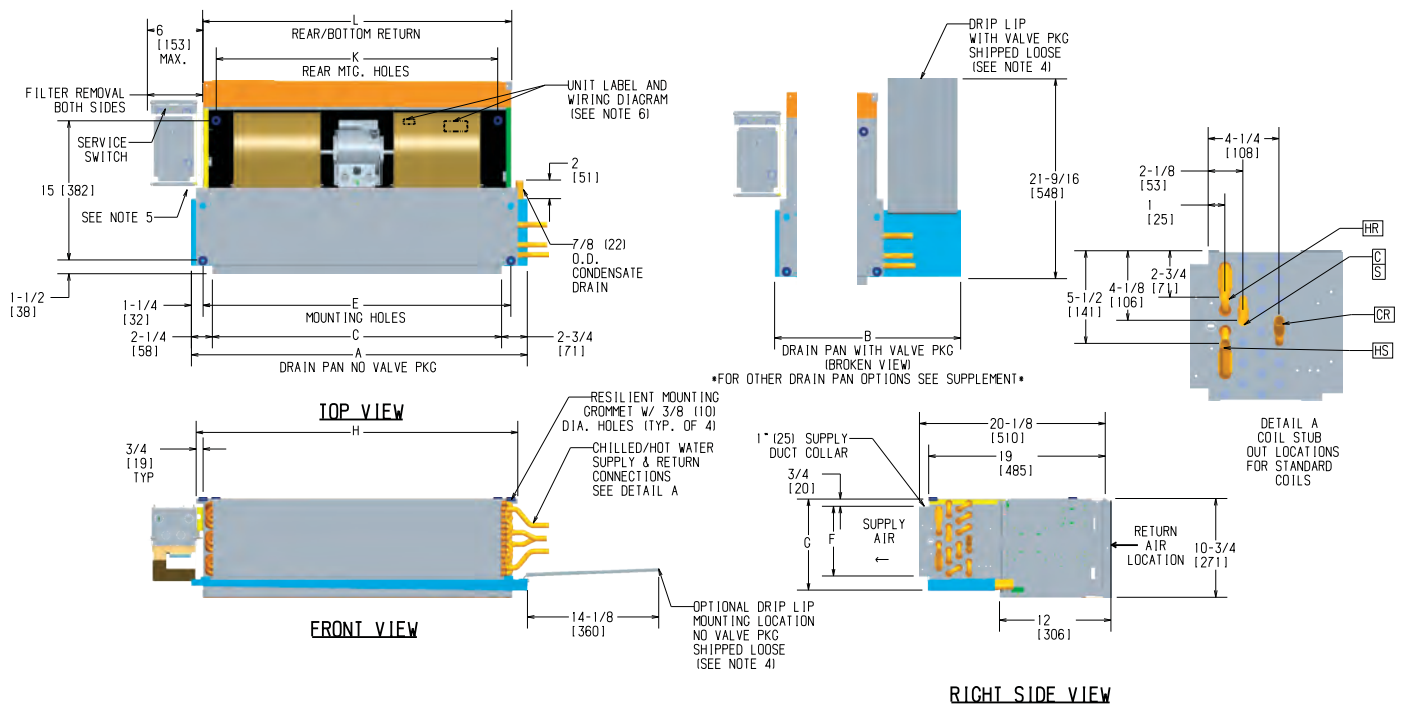

Unit Model	Dimensions - Inches (Millimeters)										Quantity/Unit		Unit Weight*
	A	B	C	E	F	G	H	K	L	Blower	Motor		
CPY02	21-1/4 (540)	28-1/2 (724)	16 (406)	18-1/4 (464)	6-1/4 (159)	8-3/4 (222)	19-3/4 (502)	15-3/8 (391)	18-1/4 (464)	1	1	57	
CPY03	25-1/4 (641)	32-1/2 (826)	20 (508)	22-1/4 (565)	6-1/4 (159)	8-3/4 (222)	23-3/4 (603)	19-3/8 (493)	22-1/4 (565)	1	1	62	
CPY04	31-1/4 (794)	38-1/2 (978)	26 (660)	28-1/4 (718)	6-1/4 (159)	8-3/4 (222)	29-3/4 (756)	25-3/8 (654)	28-1/4 (718)	2	1	72	
CPY06	36-1/4 (921)	43-1/2 (1105)	31 (787)	33-1/4 (845)	7-1/2 (191)	10 (254)	34-3/4 (883)	30-3/8 (772)	33-1/4 (845)	2	1	84	
CPY08	43-1/4 (1099)	50-1/2 (1283)	38 (965)	40-1/4 (1022)	7-1/2 (191)	10 (254)	41-3/4 (1060)	37-3/8 (950)	40-1/4 (1022)	2	1	97	
CPY10	57-1/4 (1454)	64-1/2 (1638)	52 (1321)	54-1/4 (1378)	7-1/2 (191)	10 (254)	55-3/4 (1416)	51-3/8 (1306)	54-1/4 (1378)	4	2	137	
CPY12	65-1/4 (1657)	72-1/2 (1842)	60 (1524)	62-1/4 (1581)	7-1/2 (191)	10 (254)	63-3/4 (1619)	59-3/8 (1509)	62-1/4 (1581)	4	2	156	

NOTES: * Unit weights (shown in pounds) are based on dry coils, minimum rows and exclude packaging, valves or other components.

1. RH shown, LH opposite.
2. All dimensions are +/- .25 (6). Drawing not to scale.
3. Product specifications are subject to change without notice.
4. Drip lip recommended. Provided when valve PKG is ordered.
5. Control box size and position may vary (consult factory).
6. Position may vary.
7. Service entrance is located on the bottom of the control box with knockouts.
8. Units without service switch use the knockouts on the rear side of the control box.
9. Typical size 06 unit shown with 1-Motor and 2-BLWR - Refer to table for variation.
10. See Valve Package Supplemental for piping termination.

Drawing is provided for reference only.
 Dimensions may vary with options ordered.
 Consult IEC website for submittal drawings.

Submittal Data, Cont'd.

CPY – Horizontal Hideaway with Plenum with Electric Heat

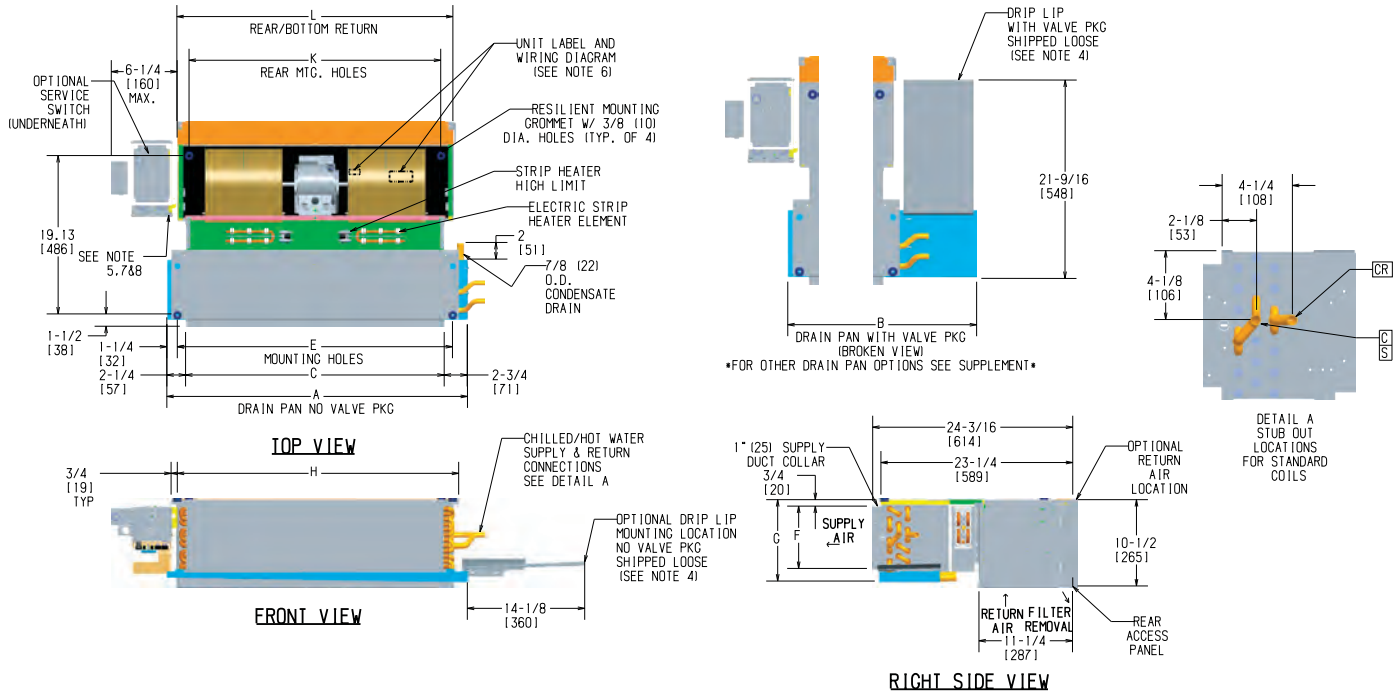

Unit Model	Dimensions - Inches (Millimeters)									Quantity/Unit		Unit Weight*
	A	B	C	E	F	G	H	K	L	Blower	Motor	
CPY02	21-1/4 (540)	28-1/2 (724)	16 (406)	18-1/4 (464)	6-1/4 (159)	8-3/4 (222)	19-3/4 (502)	15-3/8 (391)	18-1/4 (464)	1	1	57
CPY03	25-1/4 (641)	32-1/2 (826)	20 (508)	22-1/4 (565)	6-1/4 (159)	8-3/4 (222)	23-3/4 (603)	19-3/8 (493)	22-1/4 (565)	1	1	62
CPY04	31-1/4 (794)	38-1/2 (978)	26 (660)	28-1/4 (718)	6-1/4 (159)	8-3/4 (222)	29-3/4 (756)	25-3/8 (654)	28-1/4 (718)	2	1	72
CPY06	36-1/4 (921)	43-1/2 (1105)	31 (787)	33-1/4 (845)	7-1/2 (191)	10 (254)	34-3/4 (883)	30-3/8 (772)	33-1/4 (845)	2	1	84
CPY08	43-1/4 (1099)	50-1/2 (1283)	38 (965)	40-1/4 (1022)	7-1/2 (191)	10 (254)	41-3/4 (1060)	37-3/8 (950)	40-1/4 (1022)	2	1	97
CPY10	57-1/4 (1454)	64-1/2 (1638)	52 (1321)	54-1/4 (1378)	7-1/2 (191)	10 (254)	55-3/4 (1416)	51-3/8 (1306)	54-1/4 (1378)	4	2	137
CPY12	65-1/4 (1657)	72-1/2 (1842)	60 (1524)	62-1/4 (1581)	7-1/2 (191)	10 (254)	63-3/4 (1619)	59-3/8 (1509)	62-1/4 (1581)	4	2	156

NOTES: * Unit weights (shown in pounds) are based on dry coils, minimum rows and exclude packaging, valves or other components.

1. RH shown, LH opposite.
2. All dimensions are +/- .25 (6). Drawing not to scale.
3. Product specifications are subject to change without notice.
4. Drip lip recommended. Provided when valve PKG is ordered.
5. Control box size and position may vary (consult factory).
6. Position may vary.
7. Service access is located on the bottom of the control box.
8. Knockouts on the bottom and side of the control box for incoming power connections.
9. Typical size 06 unit shown with 1-Motor and 2-BLWR - Refer to table for variation.
10. See Valve Package Supplemental for piping termination.

Drawing is provided for reference only.
Dimensions may vary with options ordered.
Consult IEC website for submittal drawings.

Horizontal Series

FAN COIL TECHNICAL CATALOG

Submittal Data, Cont'd.

CPY – Horizontal Hideaway with Plenum and Side Filter Access, With Electric Heat

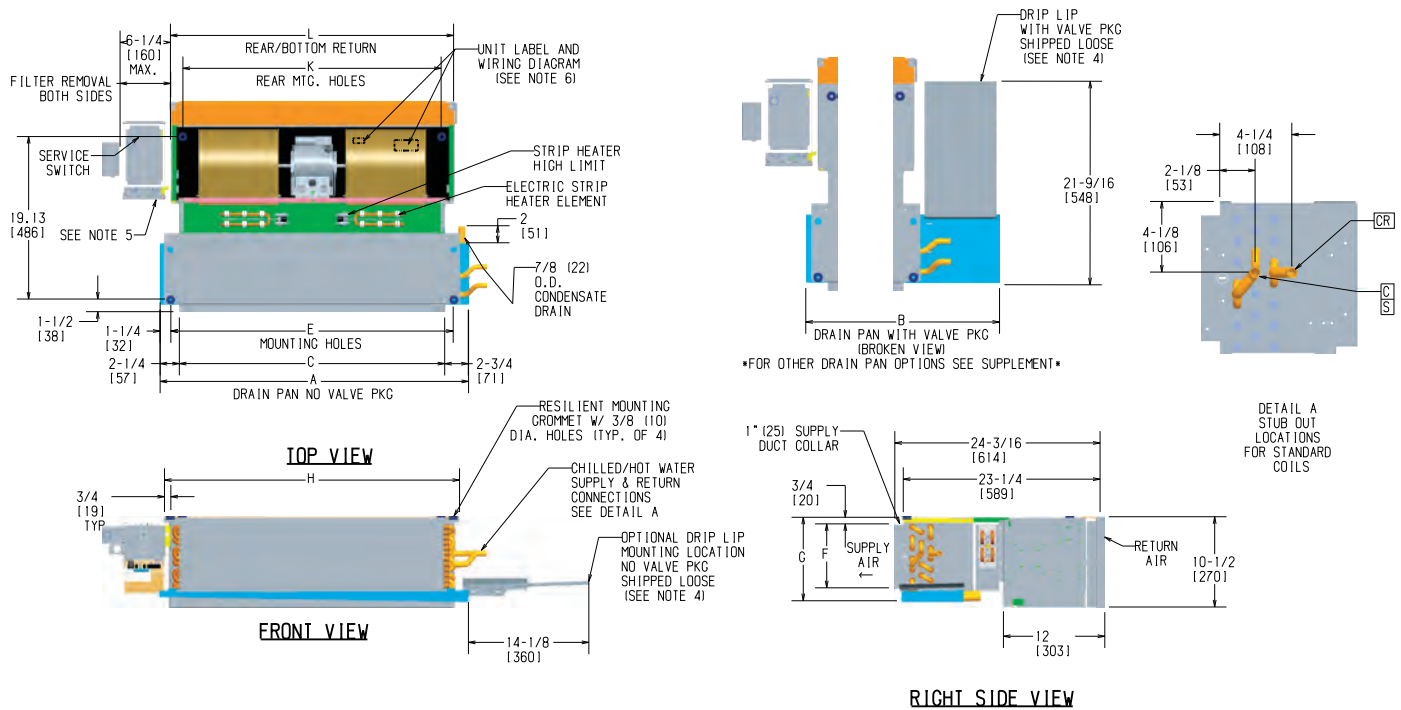

Unit Model	Dimensions - Inches (Millimeters)										Quantity/Unit		Unit Weight*
	A	B	C	E	F	G	H	K	L	Blower	Motor		
CPY02	21-1/4 (540)	28-1/2 (724)	16 (406)	18-1/4 (464)	6-1/4 (159)	8-3/4 (222)	19-3/4 (502)	15-3/8 (391)	18-1/4 (464)	1	1	57	
CPY03	25-1/4 (641)	32-1/2 (826)	20 (508)	22-1/4 (565)	6-1/4 (159)	8-3/4 (222)	23-3/4 (603)	19-3/8 (493)	22-1/4 (565)	1	1	62	
CPY04	31-1/4 (794)	38-1/2 (978)	26 (660)	28-1/4 (718)	6-1/4 (159)	8-3/4 (222)	29-3/4 (756)	25-3/8 (654)	28-1/4 (718)	2	1	72	
CPY06	36-1/4 (921)	43-1/2 (1105)	31 (787)	33-1/4 (845)	7-1/2 (191)	10 (254)	34-3/4 (883)	30-3/8 (772)	33-1/4 (845)	2	1	84	
CPY08	43-1/4 (1099)	50-1/2 (1283)	38 (965)	40-1/4 (1022)	7-1/2 (191)	10 (254)	41-3/4 (1060)	37-3/8 (950)	40-1/4 (1022)	2	1	97	
CPY10	57-1/4 (1454)	64-1/2 (1638)	52 (1321)	54-1/4 (1378)	7-1/2 (191)	10 (254)	55-3/4 (1416)	51-3/8 (1306)	54-1/4 (1378)	4	2	137	
CPY12	65-1/4 (1657)	72-1/2 (1842)	60 (1524)	62-1/4 (1581)	7-1/2 (191)	10 (254)	63-3/4 (1619)	59-3/8 (1509)	62-1/4 (1581)	4	2	156	

NOTES: * Unit weights (shown in pounds) are based on dry coils, minimum rows and exclude packaging, valves or other components.

1. RH shown, LH opposite.
2. All dimensions are +/- .25 (6). Drawing not to scale.
3. Product specifications are subject to change without notice.
4. Drip lip recommended. Provided when valve PKG is ordered.
5. Control box size and position may vary (consult factory).
6. Position may vary.
7. Service entrance is located on the bottom of the control box with knockouts.
8. Units without service switch use the knockouts on the rear side of the control box.
9. Typical size 06 unit shown with 1-Motor and 2-BLWR - Refer to table for variation.
10. See Valve Package Supplemental for piping termination.

Drawing is provided for reference only.
Dimensions may vary with options ordered.
Consult IEC website for submittal drawings.

Submittal Data, Cont'd.

CPY – Horizontal Hideaway with Plenum with Same Side Piping

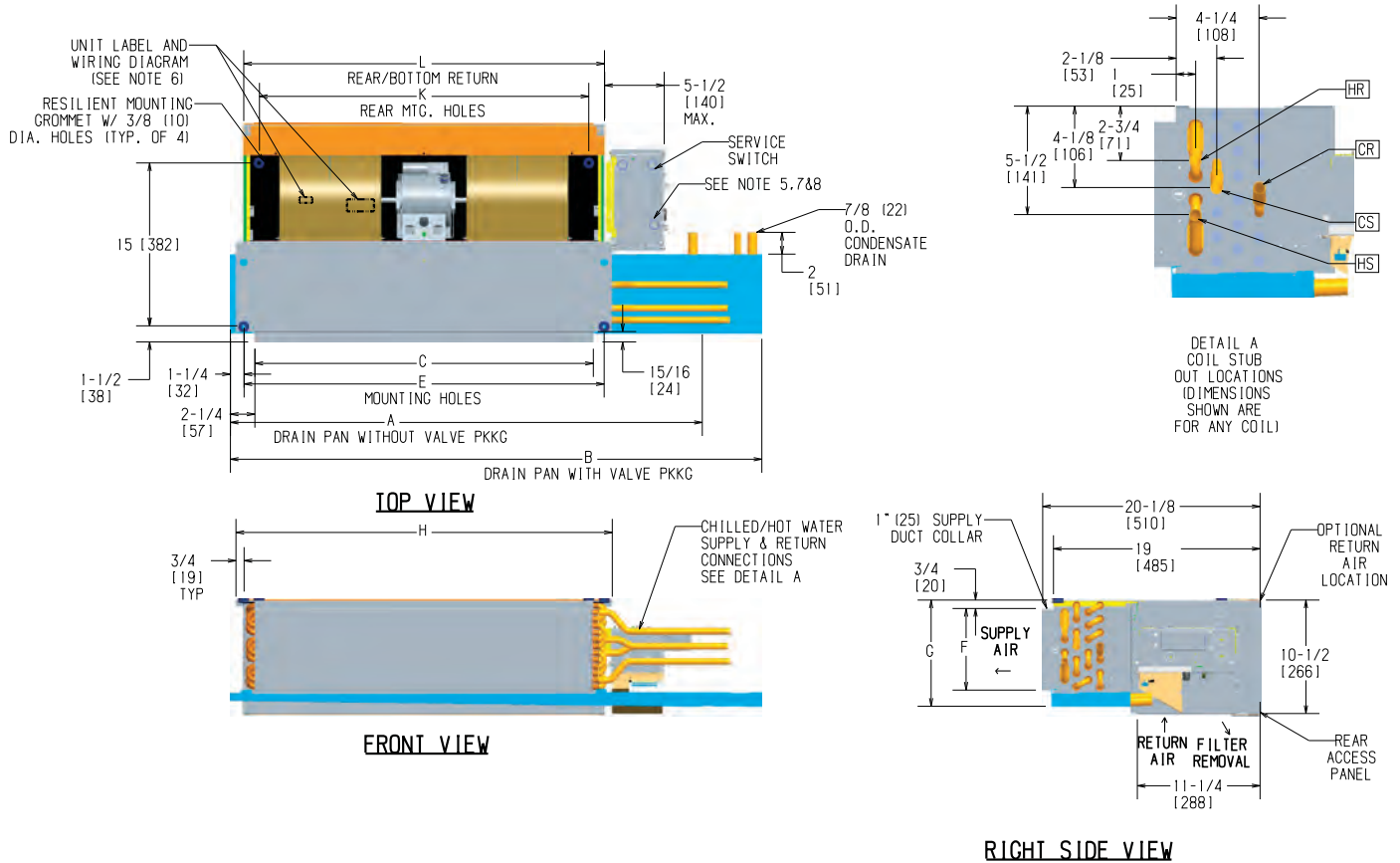

Unit Model	Dimensions - Inches (Millimeters)									Quantity/Unit		Unit Weight*
	A	B	C	E	F	G	H	K	L	Blower	Motor	
CPY02	28-1/2 (724)	34 (864)	16 (406)	18-1/4 (464)	6-1/4 (159)	8-3/4 (222)	19-3/4 (502)	15-3/8 (391)	18-1/4 (464)	1	1	55
CPY03	32-1/2 (826)	38 (965)	20 (508)	22-1/4 (565)	6-1/4 (159)	8-3/4 (222)	23-3/4 (603)	19-3/8 (493)	22-1/4 (565)	1	1	60
CPY04	38-1/2 (978)	44 (1118)	26 (660)	28-1/4 (718)	6-1/4 (159)	8-3/4 (222)	29-3/4 (756)	25-3/8 (654)	28-1/4 (718)	2	1	70
CPY06	43-1/2 (1105)	49 (1245)	31 (787)	33-1/4 (845)	7-1/2 (191)	10 (254)	34-3/4 (883)	30-3/8 (772)	33-1/4 (845)	2	1	82
CPY08	50-1/2 (1283)	56 (1422)	38 (965)	40-1/4 (1022)	7-1/2 (191)	10 (254)	41-3/4 (1060)	37-3/8 (950)	40-1/4 (1022)	2	1	95
CPY10	64-1/2 (1638)	70 (1778)	52 (1321)	54-1/4 (1378)	7-1/2 (191)	10 (254)	55-3/4 (1416)	51-3/8 (1306)	54-1/4 (1378)	4	2	135
CPY12	72-1/2 (1842)	78 (1981)	60 (1524)	62-1/4 (1581)	7-1/2 (191)	10 (254)	63-3/4 (1619)	59-3/8 (1509)	62-1/4 (1581)	4	2	154

- NOTES: *
- Unit weights (shown in pounds) are based on dry coils, minimum rows and exclude packaging, valves or other components.
 - RH shown, LH opposite.
 - All dimensions are +/- .25 (6). Drawing not to scale.
 - Product specifications are subject to change without notice.
 - Drip lip recommended. Standard when valve PKG is ordered.
 - Control box size and position may vary (consult factory).
 - Position may vary.
 - Service entrance is located on the bottom of the control box with knockouts.
 - Units without service switch use the knockouts on the rear side of the control box.
 - Typical size 06 unit shown with 1-Motor and 2-BLWR - Refer to table for variation.
 - See Valve Package Supplemental for piping termination.

Drawing is provided for reference only.
Dimensions may vary with options ordered.
Consult IEC website for submittal drawings.

Horizontal Series

FAN COIL TECHNICAL CATALOG

Submittal Data, Cont'd.

CPY – Horizontal Hideaway with Plenum and Side Filter Access, with Same Side Piping

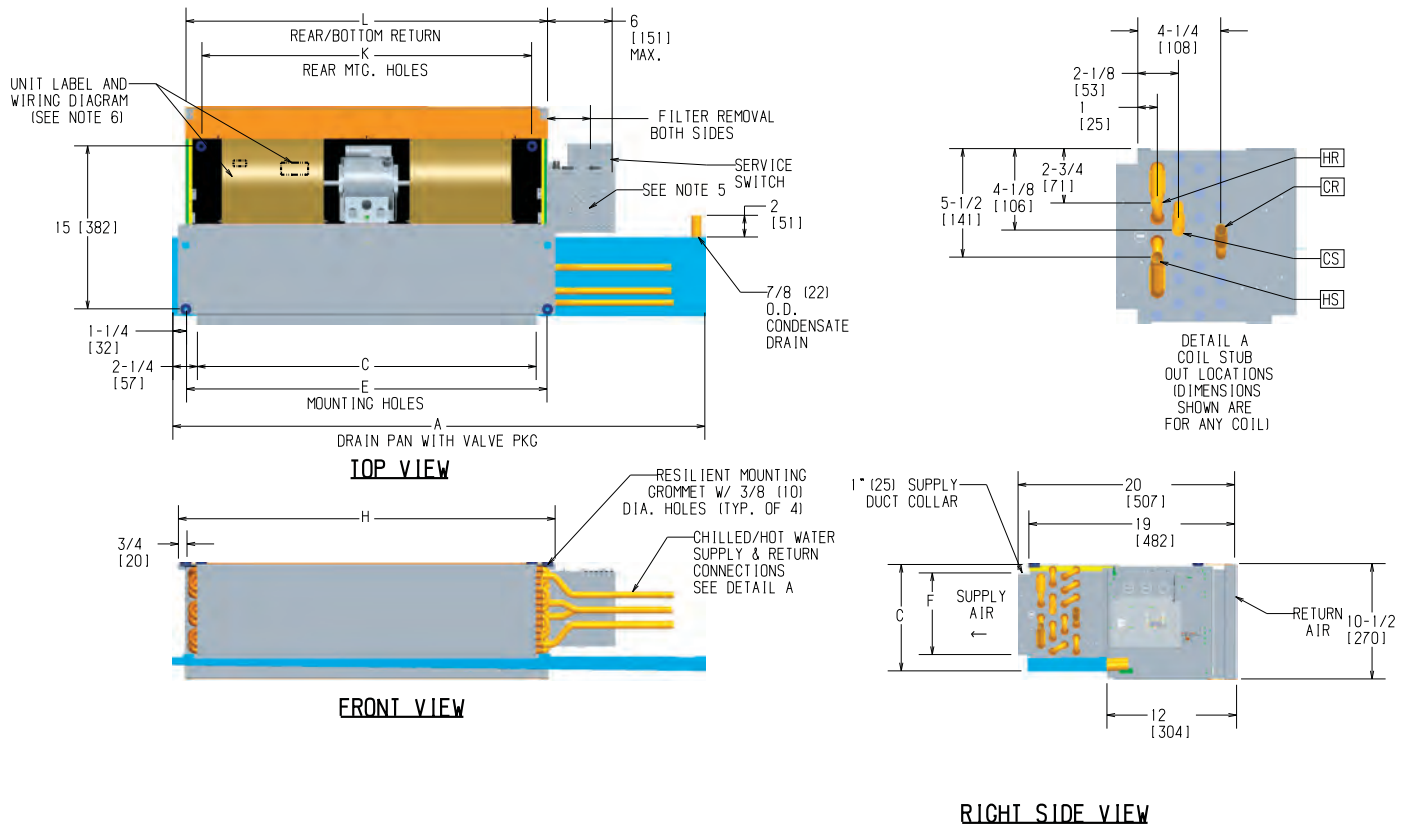

Unit Model	Dimensions - Inches (Millimeters)								Quantity/Unit		Unit Weight*
	A	C	E	F	G	H	K	L	Blower	Motor	
CPY02	34 (864)	16 (406)	18-1/4 (464)	6-1/4 (159)	8-3/4 (222)	19-3/4 (502)	15-3/8 (391)	18-1/4 (464)	1	1	57
CPY03	38 (965)	20 (508)	22-1/4 (565)	6-1/4 (159)	8-3/4 (222)	23-3/4 (603)	19-3/8 (493)	22-1/4 (565)	1	1	62
CPY04	44 (1118)	26 (660)	28-1/4 (718)	6-1/4 (159)	8-3/4 (222)	29-3/4 (756)	25-3/8 (654)	28-1/4 (718)	2	1	72
CPY06	49 (1245)	31 (787)	33-1/4 (845)	7-1/2 (191)	10 (254)	34-3/4 (883)	30-3/8 (772)	33-1/4 (845)	2	1	84
CPY08	56 (1422)	38 (965)	40-1/4 (1022)	7-1/2 (191)	10 (254)	41-3/4 (1060)	37-3/8 (950)	40-1/4 (1022)	2	1	97
CPY10	70 (1778)	52 (1321)	54-1/4 (1378)	7-1/2 (191)	10 (254)	55-3/4 (1416)	51-3/8 (1306)	54-1/4 (1378)	4	2	137
CPY12	78 (1981)	60 (1524)	62-1/4 (1581)	7-1/2 (191)	10 (254)	63-3/4 (1619)	59-3/8 (1509)	62-1/4 (1581)	4	2	156

NOTES: * Unit weights (shown in pounds) are based on dry coils, minimum rows and exclude packaging, valves or other components.

1. RH shown, LH opposite.
2. All dimensions are +/- .25 (6). Drawing not to scale.
3. Product specifications are subject to change without notice.
4. Drip lip recommended. Provided when valve PKG is ordered.
5. Control box size and position may vary (consult factory).
6. Position may vary.
7. Service entrance is located on the bottom of the control box with knockouts.
8. Units without service switch use the knockouts on the rear side of the control box.
9. Typical size 06 unit shown with 1-Motor and 2-BLWR - Refer to table for variation.
10. See Valve Package Supplemental for piping termination.

Drawing is provided for reference only.
Dimensions may vary with options ordered.
Consult IEC website for submittal drawings.

Submittal Data, Cont'd.

CPY – Horizontal Hideaway with Plenum with Same Side Piping with Electric Heat

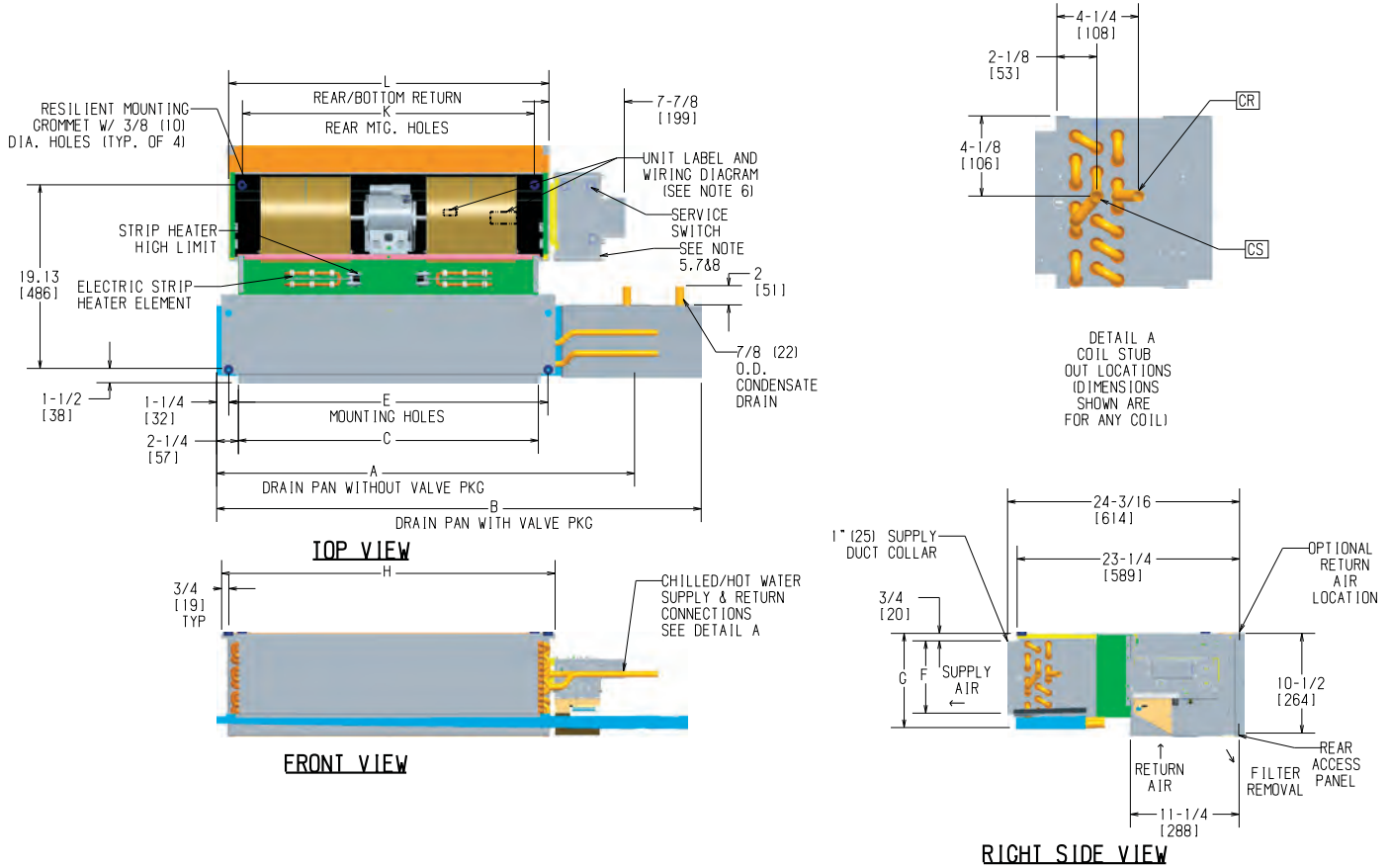

Unit Model	Dimensions - Inches (Millimeters)										Quantity/Unit		Unit Weight*
	A	B	C	E	F	G	H	K	L	Blower	Motor		
CPY02	28-1/2 (724)	34 (864)	16 (406)	18-1/4 (464)	6-1/4 (159)	8-3/4 (222)	19-3/4 (502)	15-3/8 (391)	18-1/4 (464)	1	1	57	
CPY03	32-1/2 (826)	38 (965)	20 (508)	22-1/4 (565)	6-1/4 (159)	8-3/4 (222)	23-3/4 (603)	19-3/8 (493)	22-1/4 (565)	1	1	62	
CPY04	38-1/2 (978)	44 (1118)	26 (660)	28-1/4 (718)	6-1/4 (159)	8-3/4 (222)	29-3/4 (756)	25-3/8 (654)	28-1/4 (718)	2	1	72	
CPY06	43-1/2 (1105)	49 (1245)	31 (787)	33-1/4 (845)	7-1/2 (191)	10 (254)	34-3/4 (883)	30-3/8 (772)	33-1/4 (845)	2	1	84	
CPY08	50-1/2 (1283)	56 (1422)	38 (965)	40-1/4 (1022)	7-1/2 (191)	10 (254)	41-3/4 (1060)	37-3/8 (950)	40-1/4 (1022)	2	1	97	
CPY10	64-1/2 (1638)	70 (1778)	52 (1321)	54-1/4 (1378)	7-1/2 (191)	10 (254)	55-3/4 (1416)	51-3/8 (1306)	54-1/4 (1378)	4	2	137	
CPY12	72-1/2 (1842)	78 (1981)	60 (1524)	62-1/4 (1581)	7-1/2 (191)	10 (254)	63-3/4 (1619)	59-3/8 (1509)	62-1/4 (1581)	4	2	156	

NOTES: * Unit weights (shown in pounds) are based on dry coils, minimum rows and exclude packaging, valves or other components.

1. RH shown, LH opposite.
2. All dimensions are +/- .25 (6). Drawing not to scale.
3. Product specifications are subject to change without notice.
4. Drip lip recommended. Provided when valve PKG is ordered.
5. Control box size and position may vary (consult factory).
6. Position may vary.
7. Service access is located on the bottom of the control box.
8. Knockouts on the bottom and side of the control box for incoming power connections.
9. Typical size 06 unit shown with 1-Motor and 2-BLWR - Refer to table for variation.
10. See Valve Package Supplemental for piping termination.

**Drawing is provided for reference only.
Dimensions may vary with options ordered.
Consult IEC website for submittal drawings.**

Submittal Data, Cont'd.

CPY – Horizontal Hideaway with Plenum and Side Filter Access, with Same Side Piping, With Electric Heat

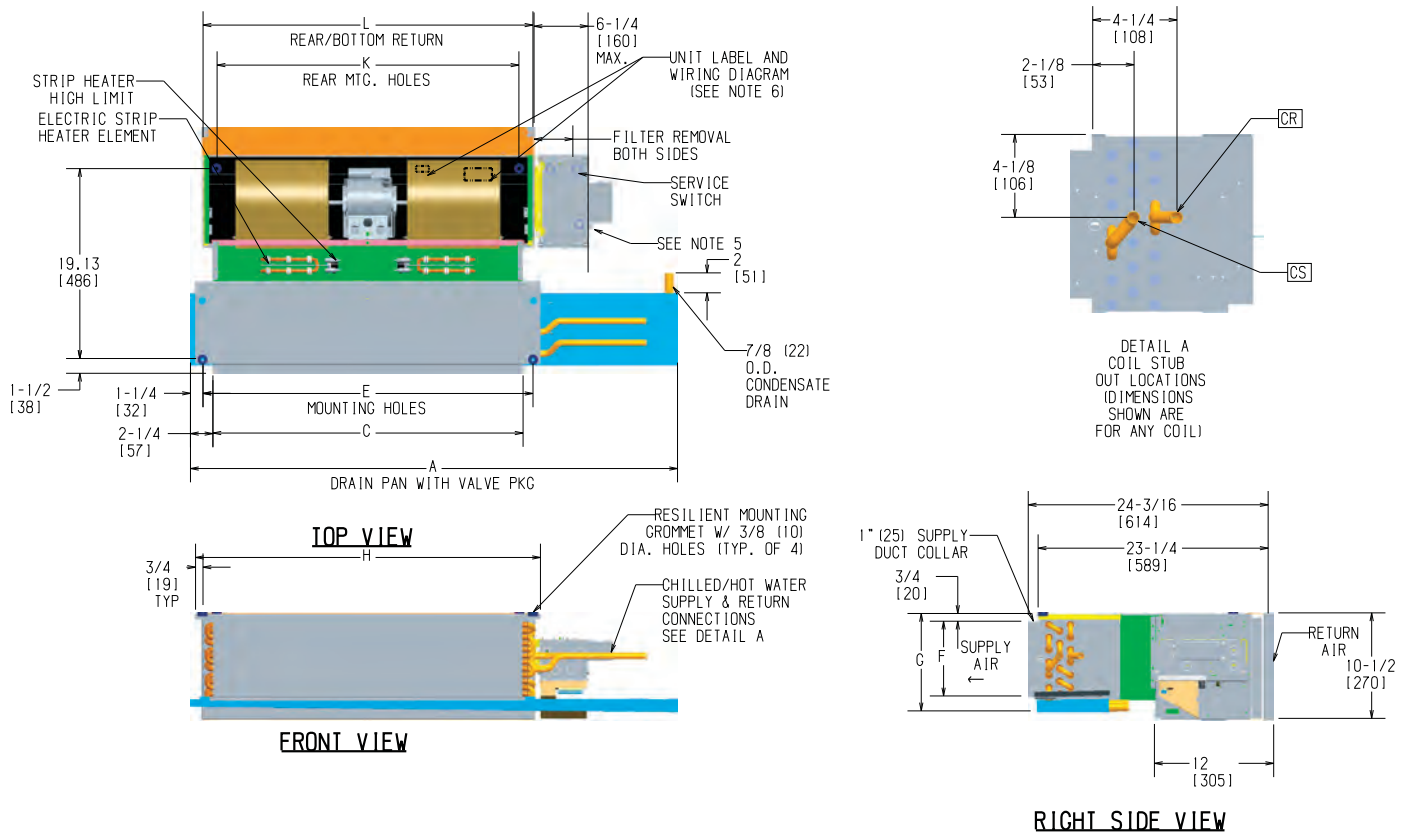

Unit Model	Dimensions - Inches (Millimeters)								Quantity/Unit		Unit Weight*
	A	C	E	F	G	H	K	L	Blower	Motor	
CPY02	34 (864)	16 (406)	18-1/4 (464)	6-1/4 (159)	8-3/4 (222)	19-3/4 (502)	15-3/8 (391)	18-1/4 (464)	1	1	57
CPY03	38 (965)	20 (508)	22-1/4 (565)	6-1/4 (159)	8-3/4 (222)	23-3/4 (603)	19-3/8 (493)	22-1/4 (565)	1	1	62
CPY04	44 (1118)	26 (660)	28-1/4 (718)	6-1/4 (159)	8-3/4 (222)	29-3/4 (756)	25-3/8 (654)	28-1/4 (718)	2	1	72
CPY06	49 (1245)	31 (787)	33-1/4 (845)	7-1/2 (191)	10 (254)	34-3/4 (883)	30-3/8 (772)	33-1/4 (845)	2	1	84
CPY08	56 (1422)	38 (965)	40-1/4 (1022)	7-1/2 (191)	10 (254)	41-3/4 (1060)	37-3/8 (950)	40-1/4 (1022)	2	1	97
CPY10	70 (1778)	52 (1321)	54-1/4 (1378)	7-1/2 (191)	10 (254)	55-3/4 (1416)	51-3/8 (1306)	54-1/4 (1378)	4	2	137
CPY12	78 (1981)	60 (1524)	62-1/4 (1581)	7-1/2 (191)	10 (254)	63-3/4 (1619)	59-3/8 (1509)	62-1/4 (1581)	4	2	156

NOTES: * Unit weights (shown in pounds) are based on dry coils, minimum rows and exclude packaging, valves or other components.

1. RH shown, LH opposite.
2. All dimensions are +/- .25 (6). Drawing not to scale.
3. Product specifications are subject to change without notice.
4. Drip lip recommended. Provided when valve PKG is ordered.
5. Control box size and position may vary (consult factory).
6. Position may vary.
7. Service entrance is located on the bottom of the control box with knockouts.
8. Units without service switch use the knockouts on the rear side of the control box.
9. Typical size 06 unit shown with 1-Motor and 2-BLWR - Refer to table for variation.
10. See Valve Package Supplemental for piping termination.

Drawing is provided for reference only.
Dimensions may vary with options ordered.
Consult IEC website for submittal drawings.

Submittal Data, Cont'd.

CPY – Horizontal Hideaway with Plenum, with Same Side Piping, with Valve Package Enclosure

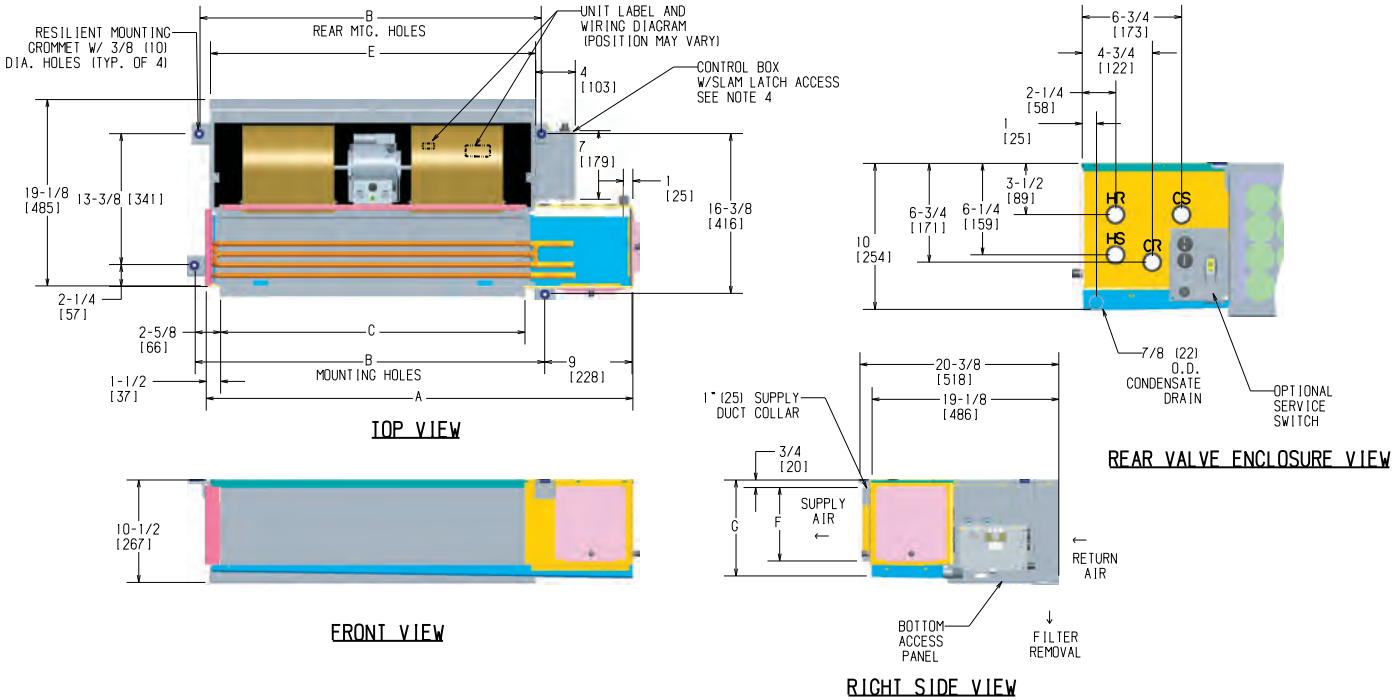

Unit Model	Dimensions - Inches (Millimeters)						Quantity/Unit		Unit Weight*
	A	B	C	E	F	G	Blower	Motor	
CPY02	28-1/4 (718)	20-3/4 (527)	16 (406)	18-1/4 (464)	6-1/4 (159)	8-3/4 (222)	1	1	57
CPY03	32-1/4 (819)	24-3/4 (629)	20 (508)	22-1/4 (565)	6-1/4 (159)	8-3/4 (222)	1	1	62
CPY04	38-1/4 (972)	30-3/4 (908)	26 (660)	28-1/4 (718)	6-1/4 (159)	8-3/4 (222)	2	1	72
CPY06	43-1/4 (1098)	35-3/4 (908)	31 (787)	33-1/4 (845)	7-1/2 (191)	10 (254)	2	1	84
CPY08	50-1/4 (1276)	42-1/2 (1080)	38 (965)	40-1/4 (1022)	7-1/2 (191)	10 (254)	2	1	97
CPY10	64-1/4 (1632)	56-1/2 (1435)	52 (1321)	54-1/4 (1378)	7-1/2 (191)	10 (254)	4	2	137
CPY12	72-1/4 (1835)	64-1/2 (1638)	60 (1524)	62-1/4 (1581)	7-1/2 (191)	10 (254)	4	2	156

- NOTES:**
- * Unit weights (shown in pounds) are based on dry coils, minimum rows and exclude packaging, valves or other components.
 1. RH shown, LH opposite.
 2. All dimensions are +/- .25 (6). Drawing not to scale.
 3. Product specifications are subject to change without notice.
 4. Control box size and position may vary (consult factory).
 5. Service entrance is located on the rear of the control box with knockouts.
 6. Units without service switch use the knockouts on the rear side of the control box.
 7. Typical size 06 unit shown with 1-Motor and 2-BLWR - Refer to table for variation.

Drawing is provided for reference only.
Dimensions may vary with options ordered.
Consult IEC website for submittal drawings.

Submittal Data, Cont'd.

CPY – Horizontal Hideaway with Plenum, with Same Side Piping, with Electric Heat, with Valve Package Enclosure

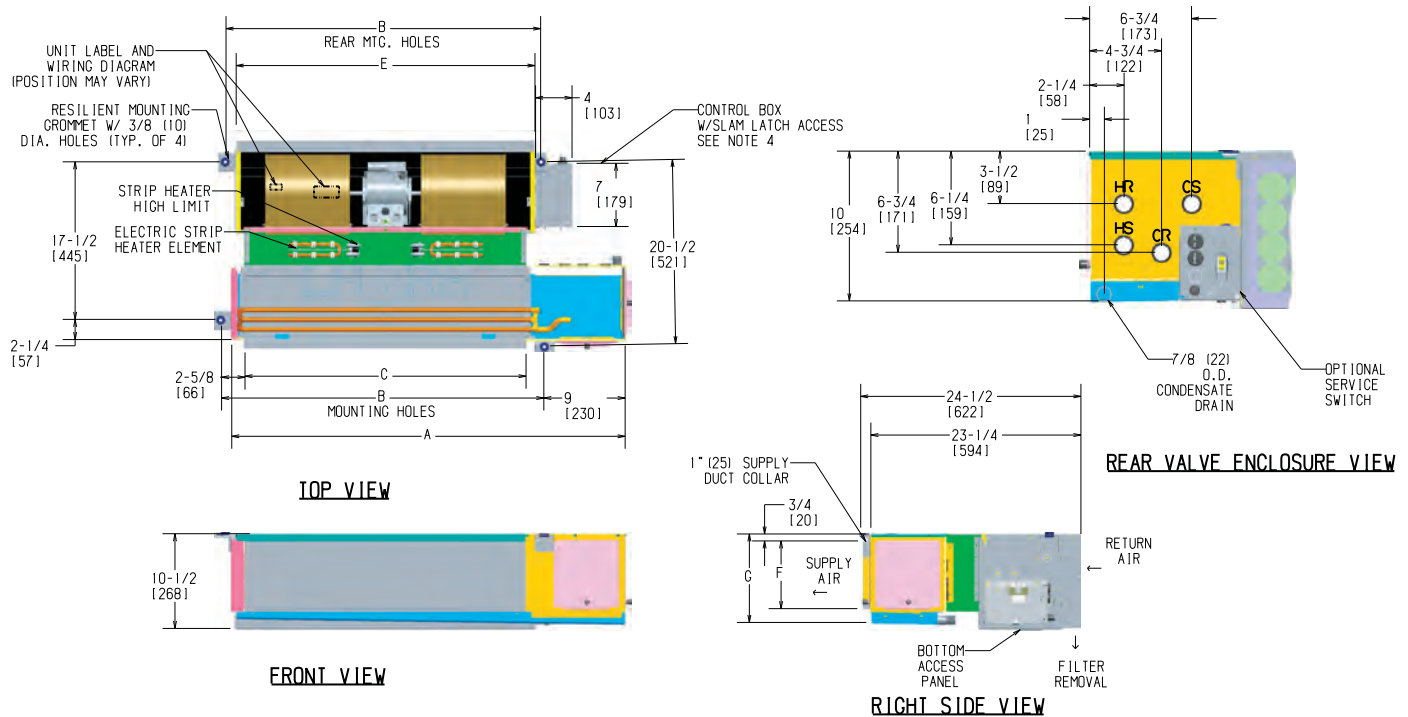

Unit Model	Dimensions - Inches (Millimeters)						Quantity/Unit		Unit Weight*
	A	B	C	E	F	G	Blower	Motor	
CPY02	28-1/4 (718)	20-3/4 (527)	16 (406)	18-1/4 (464)	6-1/4 (159)	8-3/4 (222)	1	1	57
CPY03	32-1/4 (819)	24-3/4 (629)	20 (508)	22-1/4 (565)	6-1/4 (159)	8-3/4 (222)	1	1	62
CPY04	38-1/4 (972)	30-3/4 (908)	26 (660)	28-1/4 (718)	6-1/4 (159)	8-3/4 (222)	2	1	72
CPY06	43-1/4 (1098)	35-3/4 (908)	31 (787)	33-1/4 (845)	7-1/2 (191)	10 (254)	2	1	84
CPY08	50-1/4 (1276)	42-1/2 (1080)	38 (965)	40-1/4 (1022)	7-1/2 (191)	10 (254)	2	1	97
CPY10	64-1/4 (1632)	56-1/2 (1435)	52 (1321)	54-1/4 (1378)	7-1/2 (191)	10 (254)	4	2	137
CPY12	72-1/4 (1835)	64-1/2 (1638)	60 (1524)	62-1/4 (1581)	7-1/2 (191)	10 (254)	4	2	156

- NOTES:**
- * Unit weights (shown in pounds) are based on dry coils, minimum rows and exclude packaging, valves or other components.
 - 1. RH shown, LH opposite.
 - 2. All dimensions are +/- .25 (6). Drawing not to scale.
 - 3. Product specifications are subject to change without notice.
 - 4. Control box size and position may vary (consult factory).
 - 5. Service entrance is located on the rear of the control box with knockouts.
 - 6. Units without service switch use the knockouts on the rear side of the control box.
 - 7. Typical size 06 unit shown with 1-Motor and 2-BLWR - Refer to table for variation.

Drawing is provided for reference only.
 Dimensions may vary with options ordered.
 Consult IEC website for submittal drawings.

Submittal Data, Cont'd.

CBY – Horizontal Telescoping Hideaway

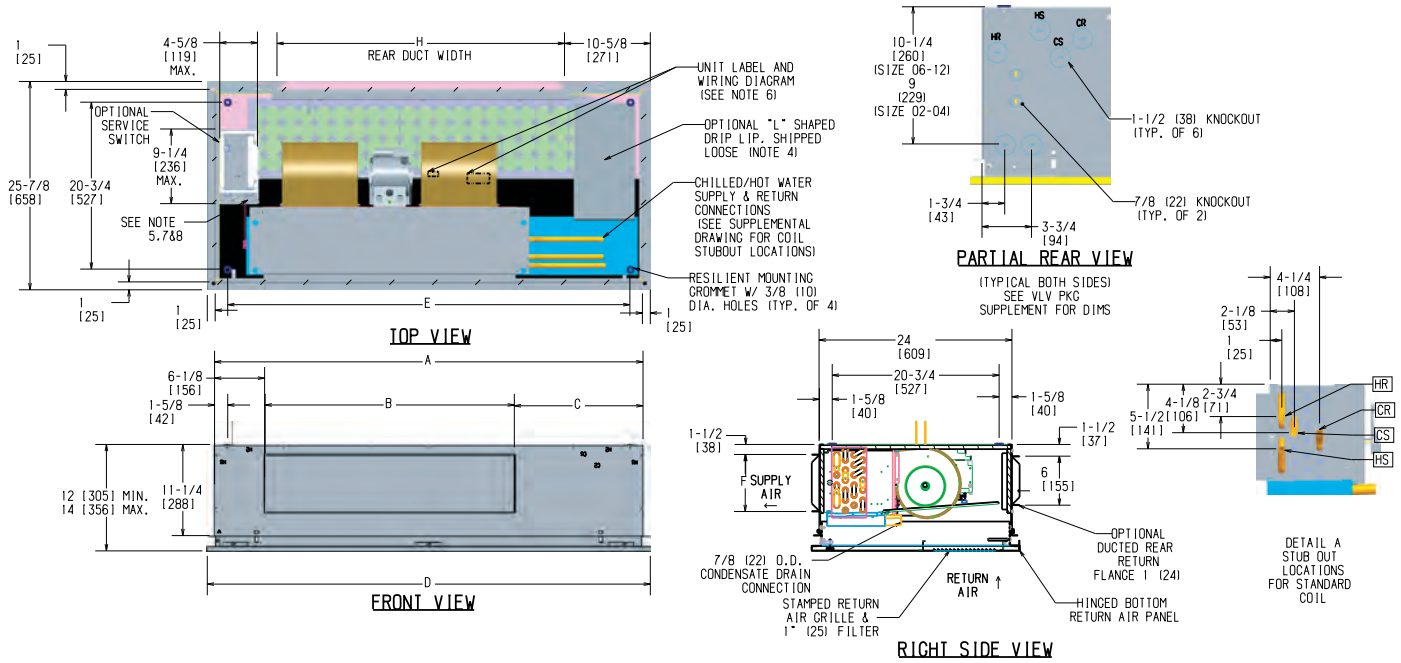

Unit Model	Dimensions - Inches (Millimeters)							Quantity/Unit		Unit Weight*
	A	B	C	D	E	F	H	Blower	Motor	
CBY02	35 (889)	16 (406)	12-3/4 (324)	37 (940)	32 (813)	6 (152)	18-3/4 (476)	1	1	55
CBY03	35 (889)	20 (508)	8-3/4 (225)	37 (940)	32 (813)	6 (152)	18-3/4 (476)	1	1	60
CBY04	41 (1041)	26 (660)	8-3/4 (225)	43 (1092)	38 (965)	6 (152)	24-3/4 (629)	2	1	70
CBY06	53 (1346)	31 (787)	15-3/4 (400)	55 (1397)	50 (1270)	7 (179)	35-3/4 (908)	2	1	82
CBY08	53 (1346)	38 (965)	8-3/4 (225)	55 (1397)	50 (1270)	7 (179)	35-3/4 (908)	2	1	95
CBY10	75 (1905)	52 (1321)	16-3/4 (425)	77 (1956)	72 (1829)	7 (179)	49-3/4 (1264)	4	2	135
CBY12	75 (1905)	60 (1524)	8-3/4 (225)	77 (1956)	72 (1829)	7 (179)	49-3/4 (1264)	4	2	154

- NOTES:**
- * Unit weights (shown in pounds) are based on dry coils, minimum rows and exclude packaging, valves or other components.
 - RH shown, LH opposite.
 - All dimensions are +/- .25 (6). Drawing not to scale.
 - Product specifications are subject to change without notice.
 - Drip lip recommended. Provided when valve PKG is ordered.
 - Control box size and position may vary (consult factory).
 - Position may vary.
 - Service access is located on the front of the control box.
 - Knockouts on the bottom and side of the control box for incoming power connections.
 - Typical size 06 unit shown with 1-Motor and 2-BLWR - Refer to table for variation.
 - See Valve Package Supplemental for piping termination.
 - Field Connection Pipes will be shipped loose with valve packages.

Drawing is provided for reference only.
Dimensions may vary with options ordered.
Consult IEC website for submittal drawings.

Horizontal Series

FAN COIL TECHNICAL CATALOG

Submittal Data, Cont'd.

CBY – Horizontal Telescoping Hideaway with Electric Heat

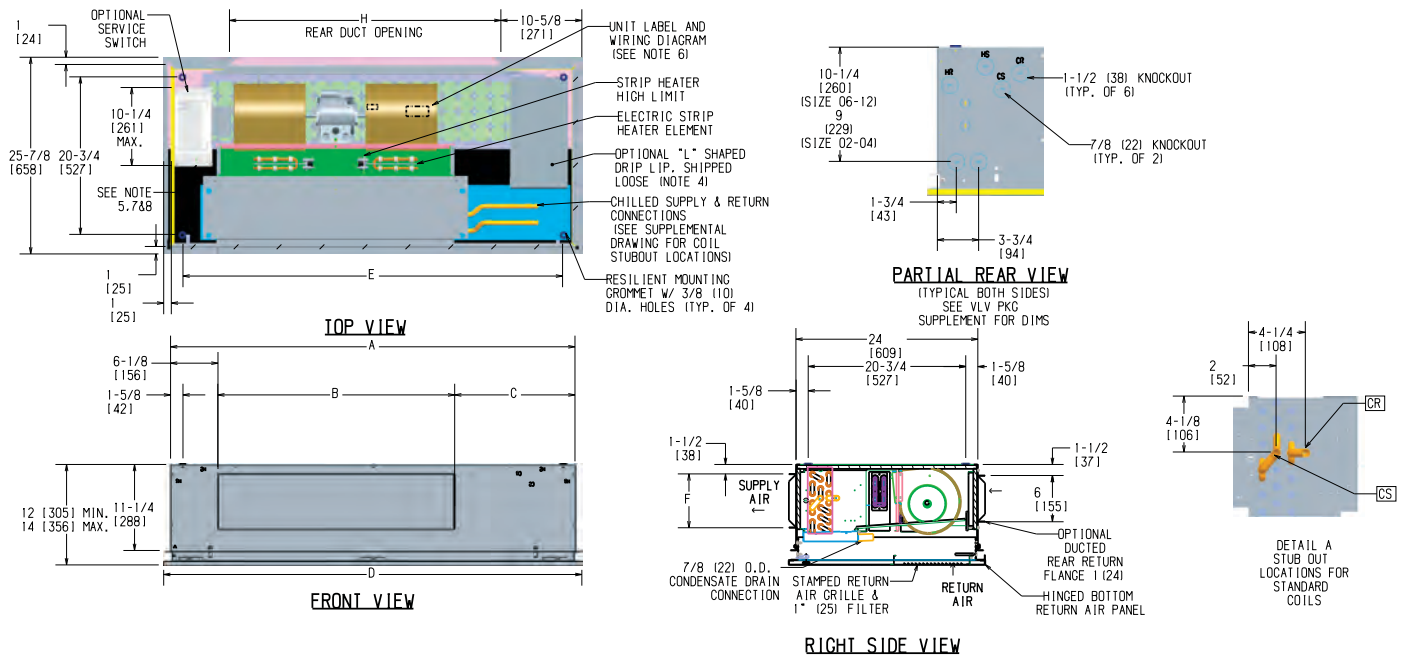

Unit Model	Dimensions - Inches (Millimeters)							Quantity/Unit		Unit Weight*
	A	B	C	D	E	F	H	Blower	Motor	
CBY02	35 (889)	16 (406)	12-3/4 (324)	37 (940)	32 (813)	6 (152)	18-3/4 (476)	1	1	55
CBY03	35 (889)	20 (508)	8-3/4 (225)	37 (940)	32 (813)	6 (152)	18-3/4 (476)	1	1	60
CBY04	41 (1041)	26 (660)	8-3/4 (225)	43 (1092)	38 (965)	6 (152)	24-3/4 (629)	2	1	70
CBY06	53 (1346)	31 (787)	15-3/4 (400)	55 (1397)	50 (1270)	7 (179)	35-3/4 (908)	2	1	82
CBY08	53 (1346)	38 (965)	8-3/4 (225)	55 (1397)	50 (1270)	7 (179)	35-3/4 (908)	2	1	95
CBY10	75 (1905)	52 (1321)	16-3/4 (425)	77 (1956)	72 (1829)	7 (179)	49-3/4 (1264)	4	2	135
CBY12	75 (1905)	60 (1524)	8-3/4 (225)	77 (1956)	72 (1829)	7 (179)	49-3/4 (1264)	4	2	154

NOTES: * Unit weights (shown in pounds) are based on dry coils, minimum rows and exclude packaging, valves or other components.

1. RH shown, LH opposite.
2. All dimensions are +/- .25 (6). Drawing not to scale.
3. Product specifications are subject to change without notice.
4. Drip lip recommended. Provided when valve PKG is ordered.
5. Control box size and position may vary (consult factory).
6. Position may vary.
7. Service access is located on the front of the control box.
8. Knockouts on the bottom and side of the control box for incoming power connections.
9. Typical size 06 unit shown with 1-Motor and 2-BLWR - Refer to table for variation.
10. See Valve Package Supplemental for piping termination.
11. Field Connection Pipes will be shipped loose with valve packages.

Drawing is provided for reference only.
Dimensions may vary with options ordered.
Consult IEC website for submittal drawings.

Submittal Data, Cont'd.

CBY – Horizontal Telescoping Hideaway with Bottom Supply

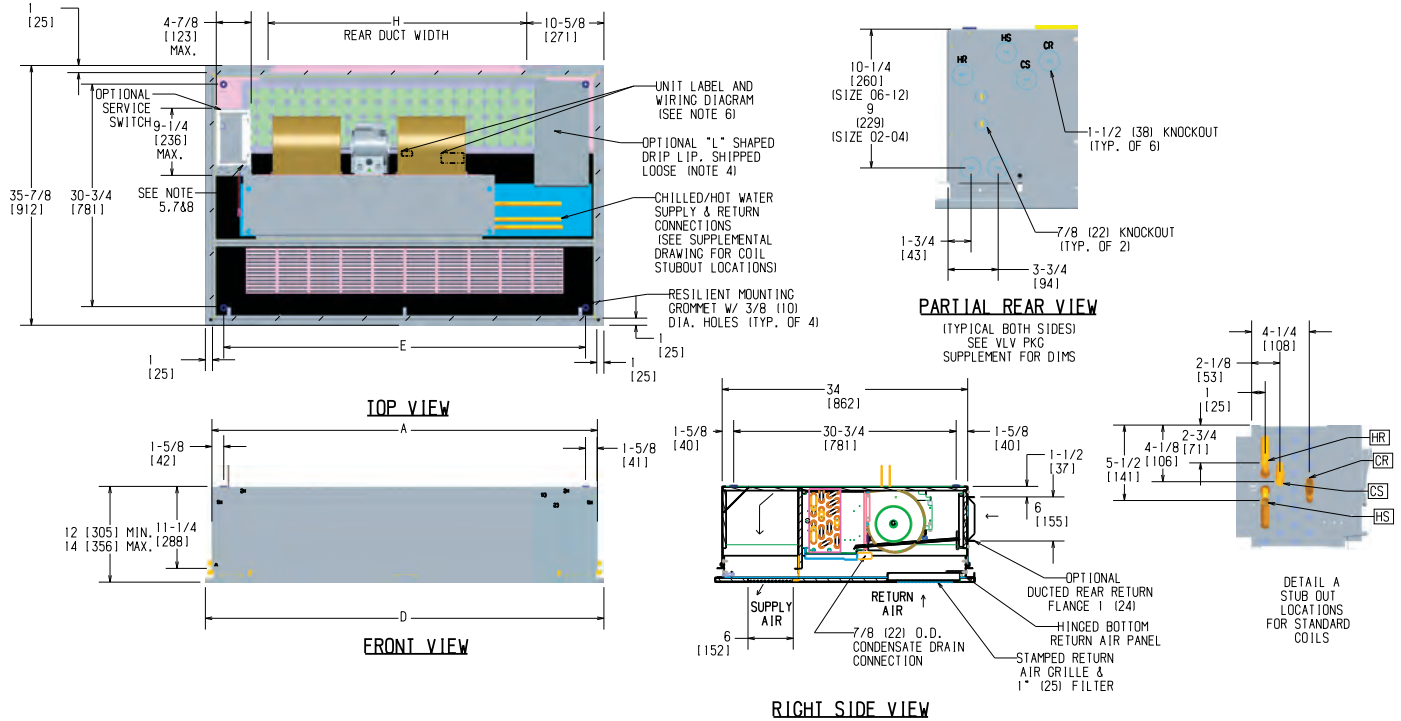

Unit Model	Dimensions - Inches (Millimeters)				Quantity/Unit		Unit Weight*
	A	D	E	H	Blower	Motor	
CBY02	35 (889)	37 (940)	32 (813)	18-3/4 (476)	1	1	55
CBY03	35 (889)	37 (940)	32 (813)	18-3/4 (476)	1	1	60
CBY04	41 (1041)	43 (1092)	32 (813)	24-3/4 (629)	2	1	70
CBY06	53 (1346)	55 (1397)	50 (1270)	35-3/4 (908)	2	1	82
CBY08	53 (1346)	55 (1397)	50 (1270)	35-3/4 (908)	2	1	95
CBY10	75 (1905)	77 (1956)	72 (1829)	49-3/4 (1264)	4	2	135
CBY12	75 (1905)	77 (1956)	72 (1829)	49-3/4 (1264)	4	2	154

- NOTES:**
- * Unit weights (shown in pounds) are based on dry coils, minimum rows and exclude packaging, valves or other components.
 1. RH shown, LH opposite.
 2. All dimensions are +/- .25 (6). Drawing not to scale.
 3. Product specifications are subject to change without notice.
 4. Drip lip recommended. Provided when valve PKG is ordered.
 5. Control box size and position may vary (consult factory).
 6. Position may vary.
 7. Service access is located on the front of the control box.
 8. Knockouts on the bottom and side of the control box for incoming power connections.
 9. Typical size 06 unit shown with 1-Motor and 2-BLWR - Refer to table for variation.
 10. See Valve Package Supplemental for piping termination.
 11. Field Connection Pipes will be shipped loose with valve packages.

Drawing is provided for reference only.
 Dimensions may vary with options ordered.
 Consult IEC website for submittal drawings.

Horizontal Series

FAN COIL TECHNICAL CATALOG

Submittal Data, Cont'd.

CBY – Horizontal Telescoping Hideaway with Bottom Supply with Electric Heat

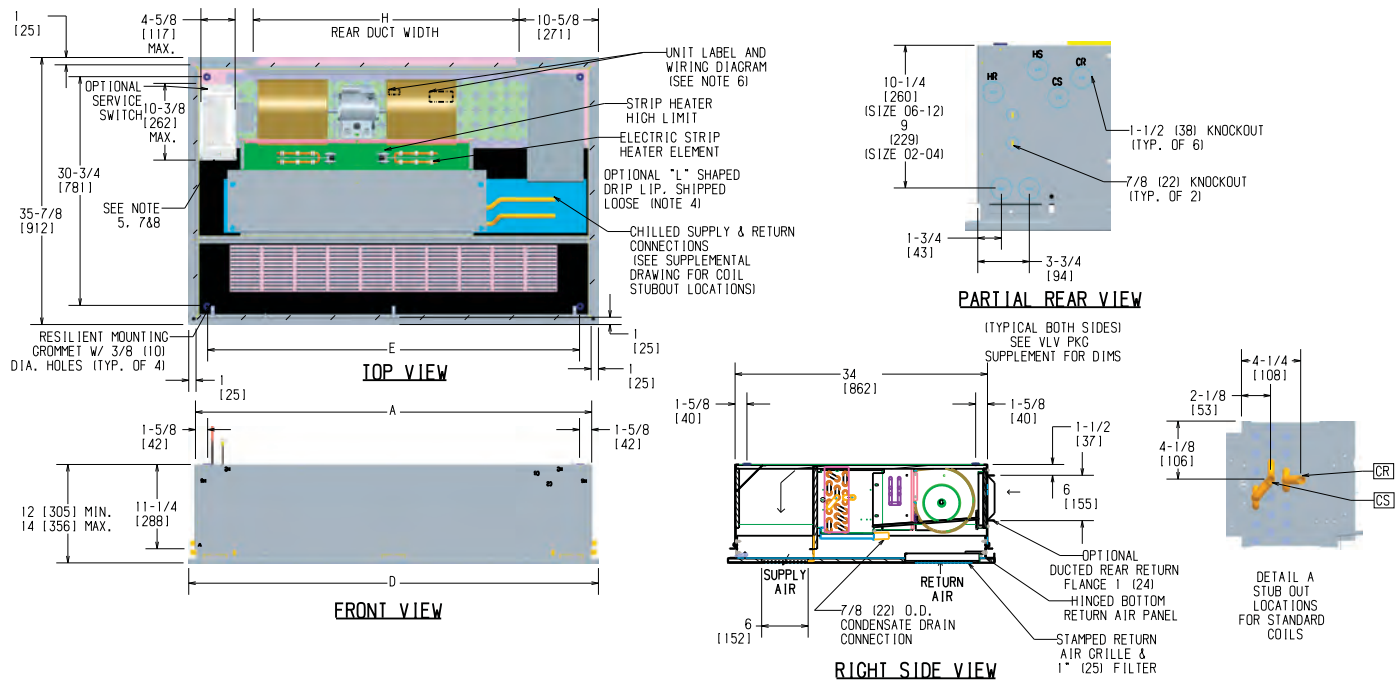

Unit Model	Dimensions - Inches (Millimeters)				Quantity/Unit		Unit Weight*
	A	D	E	H	Blower	Motor	
CBY02	35 (889)	37 (940)	32 (813)	18-3/4 (476)	1	1	117
CBY03	35 (889)	37 (940)	32 (813)	18-3/4 (476)	1	1	122
CBY04	41 (1041)	43 (1092)	32 (813)	24-3/4 (629)	2	1	137
CBY06	53 (1346)	55 (1397)	50 (1270)	35-3/4 (908)	2	1	152
CBY08	53 (1346)	55 (1397)	50 (1270)	35-3/4 (908)	2	1	157
CBY10	75 (1905)	77 (1956)	72 (1829)	49-3/4 (1264)	4	2	229
CBY12	75 (1905)	77 (1956)	72 (1829)	49-3/4 (1264)	4	2	243

NOTES: * Unit weights (shown in pounds) are based on dry coils, minimum rows and exclude packaging, valves or other components.

1. RH shown, LH opposite.
2. All dimensions are +/- .25 (6). Drawing not to scale.
3. Product specifications are subject to change without notice.
4. Drip lip recommended. Provided when valve PKG is ordered.
5. Control box size and position may vary (consult factory).
6. Position may vary.
7. Service access is located on the front of the control box.
8. Knockouts on the bottom and side of the control box for incoming power connections.
9. Typical size 06 unit shown with 1-Motor and 2-BLWR - Refer to table for variation.
10. See Valve Package Supplemental for piping termination.
11. Field Connection Pipes will be shipped loose with valve packages.

Drawing is provided for reference only.
Dimensions may vary with options ordered.
Consult IEC website for submittal drawings.

Submittal Data, Cont'd.

CXB – Horizontal Cabinet

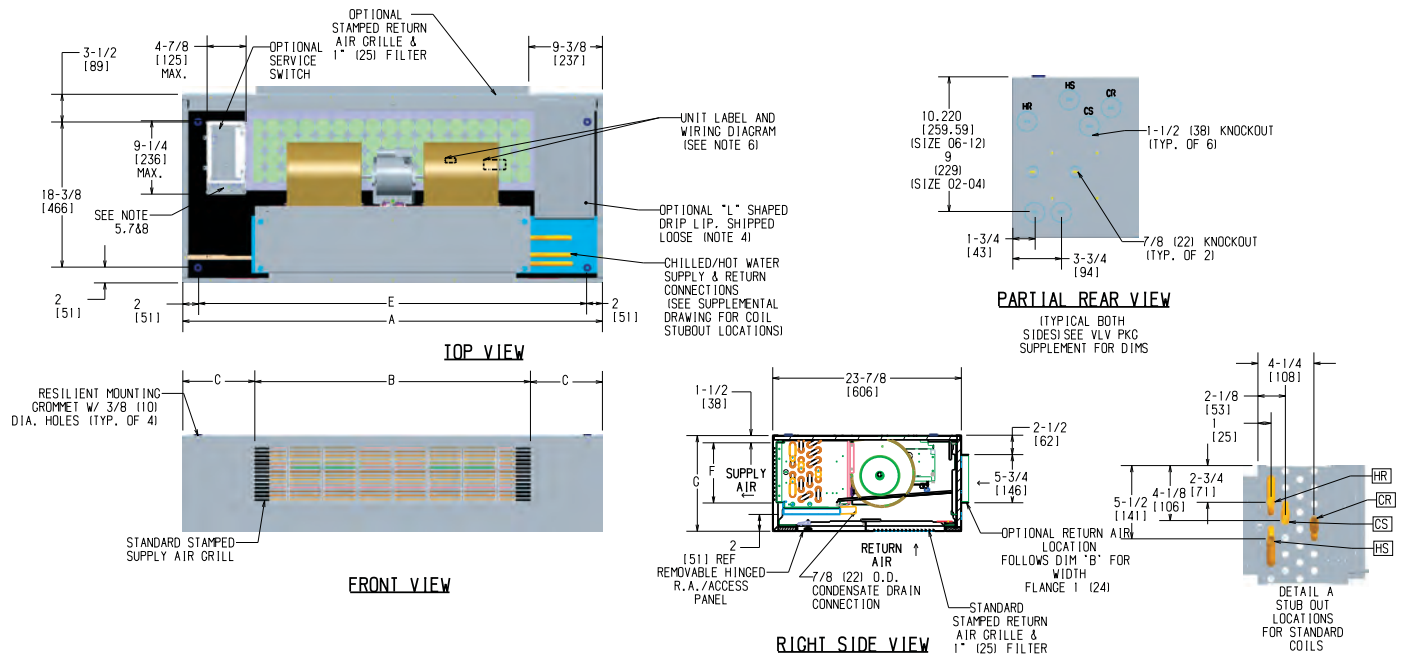

Unit Model	Dimensions - Inches (Millimeters)						Quantity/Unit		Unit Weight*
	A	B	C	E	F	G	Blower	Motor	
CXB02	38 (965)	17-1/8 (435)	10-7/16 (265)	34 (864)	5-3/4 (146)	11 (279)	1	1	98
CXB03	42 (1067)	21-1/2 (546)	10-1/4 (260)	38 (965)	5-3/4 (146)	11 (279)	1	1	118
CXB04	48 (1219)	25-7/8 (657)	11-1/16 (281)	44 (1118)	5-3/4 (146)	11 (279)	2	1	126
CXB06	53 (1346)	34-5/8 (879)	9-3/16 (233)	49 (1245)	6-3/4 (171)	12 (305)	2	1	168
CXB08	60 (1524)	39 (991)	10-1/2 (267)	56 (1422)	6-3/4 (171)	12 (305)	2	1	176
CXB10	74 (1880)	52-1/8 (1324)	10-15/16 (262)	70 (1778)	6-3/4 (171)	12 (305)	4	2	215
CXB12	82 (2083)	60-7/8 (1546)	10-9/16 (268)	78 (1981)	6-3/4 (171)	12 (305)	4	2	245

NOTES: * Unit weights (shown in pounds) are based on dry coils, minimum rows and exclude packaging, valves or other components.

1. RH shown, LH opposite.
2. All dimensions are +/- .25 (6). Drawing not to scale.
3. Product specifications are subject to change without notice.
4. Drip lip recommended. Provided when valve PKG is ordered.
5. Control box size and position may vary (consult factory).
6. Position may vary.
7. Service access is located on the front of the control box.
8. Knockouts on the bottom and side of the control box for incoming power connections.
9. Typical size 06 unit shown with 1-Motor and 2-BLWR - Refer to table for variation.
10. See Valve Package Supplemental for piping termination.
11. Field Connection Pipes will be shipped loose with valve packages.

Drawing is provided for reference only.
Dimensions may vary with options ordered.
Consult IEC website for submittal drawings.

Horizontal Series

FAN COIL TECHNICAL CATALOG

Submittal Data, Cont'd.

CXB – Horizontal Cabinet with optional Electric Heat

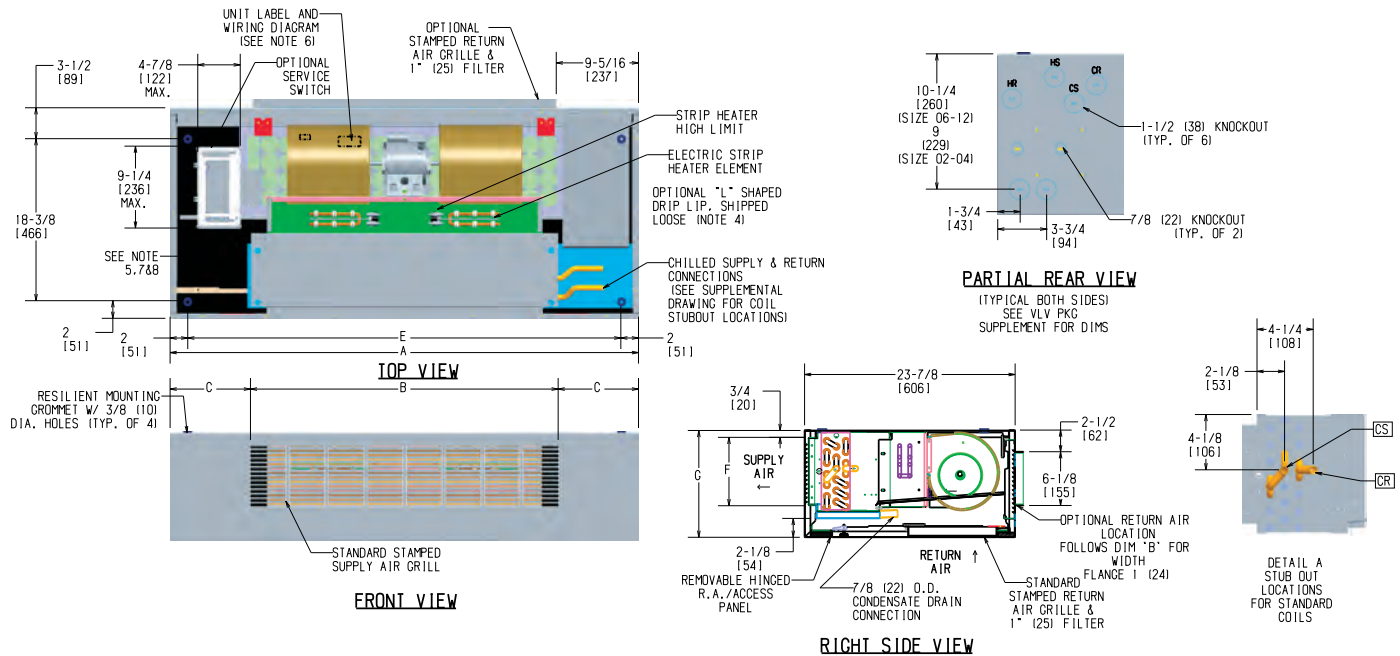

Unit Model	Dimensions - Inches (Millimeters)						Quantity/Unit		Unit Weight*
	A	B	C	E	F	G	Blower	Motor	
CXB02	38 (965)	17-1/8 (435)	10-7/16 (265)	34 (864)	5-3/4 (146)	11 (279)	1	1	100
CXB03	42 (1067)	21-1/2 (546)	10-1/4 (260)	38 (965)	5-3/4 (146)	11 (279)	1	1	120
CXB04	48 (1219)	25-7/8 (657)	11-1/16 (281)	44 (1118)	5-3/4 (146)	11 (279)	2	1	128
CXB06	53 (1346)	34-5/8 (879)	9-3/16 (233)	49 (1245)	6-3/4 (171)	12 (305)	2	1	170
CXB08	60 (1524)	39 (991)	10-1/2 (267)	56 (1422)	6-3/4 (171)	12 (305)	2	1	178
CXB10	74 (1880)	52-1/8 (1324)	10-15/16 (262)	70 (1778)	6-3/4 (171)	12 (305)	4	2	217
CXB12	82 (2083)	60-7/8 (1546)	10-9/16 (268)	78 (1981)	6-3/4 (171)	12 (305)	4	2	247

- NOTES:**
- * Unit weights (shown in pounds) are based on dry coils, minimum rows and exclude packaging, valves or other components.
 - 1. RH shown, LH opposite.
 - 2. All dimensions are +/- .25 (6). Drawing not to scale.
 - 3. Product specifications are subject to change without notice.
 - 4. Drip lip recommended. Provided when valve PKG is ordered.
 - 5. Control box size and position may vary (consult factory).
 - 6. Position may vary.
 - 7. Service access is located on the front of the control box.
 - 8. Knockouts on the bottom and side of the control box for incoming power connections.
 - 9. Typical size 06 unit shown with 1-Motor and 2-BLWR - Refer to table for variation.
 - 10. See Valve Package Supplemental for piping termination.
 - 11. Field Connection Pipes will be shipped loose with valve packages.

Drawing is provided for reference only.
 Dimensions may vary with options ordered.
 Consult IEC website for submittal drawings.

Submittal Data, Cont'd.

CXB – Horizontal Cabinet with Bottom Supply

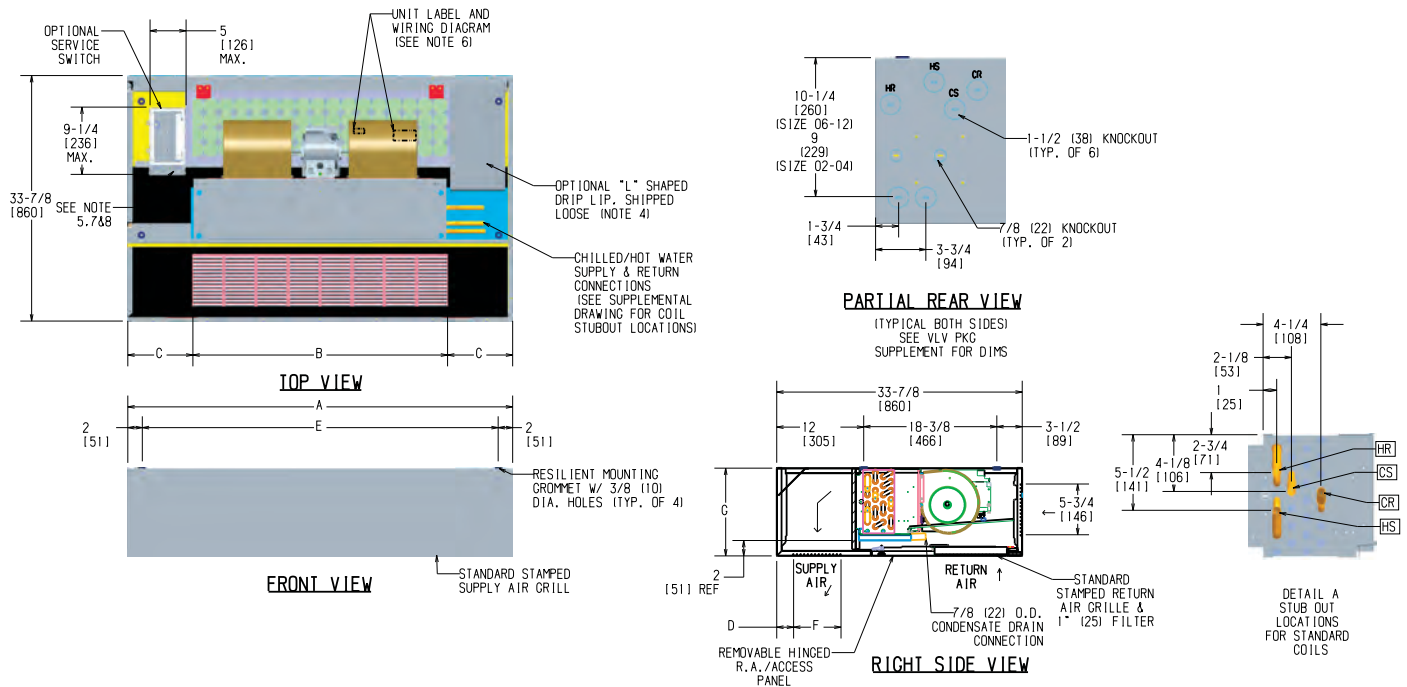

Unit Model	Dimensions - Inches (Millimeters)							Quantity/Unit		Unit Weight*
	A	B	C	D	E	F	G	Blower	Motor	
CXB02	38 (965)	17-1/8 (435)	10-7/16 (265)	3-1/4 (83)	34 (864)	5-3/4 (146)	11 (279)	1	1	98
CXB03	42 (1067)	21-1/2 (546)	10-1/4 (260)	3-1/4 (83)	38 (965)	5-3/4 (146)	11 (279)	1	1	118
CXB04	48 (1219)	25-7/8 (657)	11-1/16 (281)	3-1/2 (89)	44 (1118)	5-3/4 (146)	11 (279)	2	1	126
CXB06	53 (1346)	34-5/8 (879)	9-3/16 (233)	2-1/4 (57)	49 (1245)	6-3/4 (171)	12 (305)	2	1	168
CXB08	60 (1524)	39 (991)	10-1/2 (267)	2-1/4 (57)	56 (1422)	6-3/4 (171)	12 (305)	2	1	176
CXB10	74 (1880)	52-1/8 (1324)	10-15/16 (262)	2-1/2 (64)	70 (1778)	6-3/4 (171)	12 (305)	4	2	215
CXB12	82 (2083)	60-7/8 (1546)	10-9/16 (268)	2-1/2 (64)	78 (1981)	6-3/4 (171)	12 (305)	4	2	245

- NOTES:**
- * Unit weights (shown in pounds) are based on dry coils, minimum rows and exclude packaging, valves or other components.
 1. RH shown, LH opposite.
 2. All dimensions are +/- .25 (6). Drawing not to scale.
 3. Product specifications are subject to change without notice.
 4. Drip lip recommended. Provided when valve PKG is ordered.
 5. Control box size and position may vary (consult factory).
 6. Position may vary.
 7. Service access is located on the front of the control box.
 8. Knockouts on the bottom and side of the control box for incoming power connections.
 9. Typical size 06 unit shown with 1-Motor and 2-BLWR - Refer to table for variation.
 10. See Valve Package Supplemental for piping termination.
 11. Field Connection Pipes will be shipped loose with valve packages.

Drawing is provided for reference only.
Dimensions may vary with options ordered.
Consult IEC website for submittal drawings.

Horizontal Series

FAN COIL TECHNICAL CATALOG

Submittal Data, Cont'd.

CXB – Horizontal Cabinet with Bottom Supply and with Electric Heat

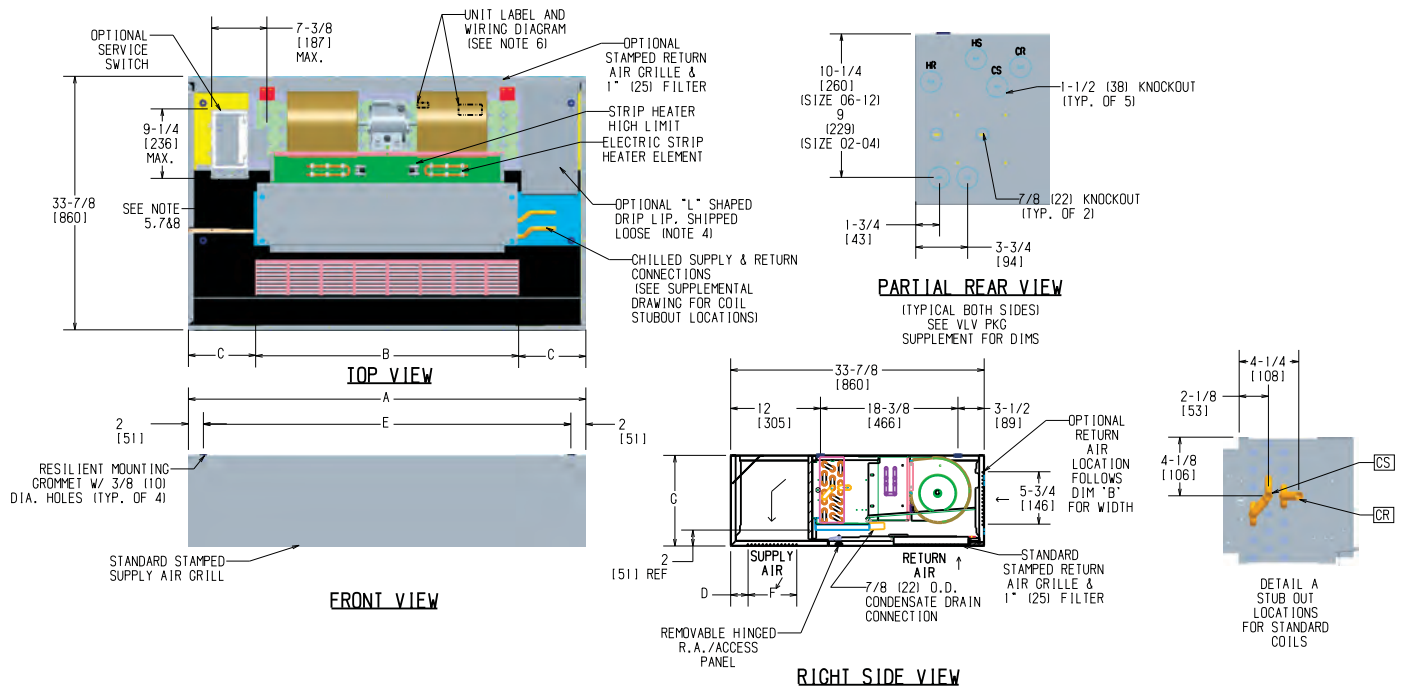

Unit Model	Dimensions - Inches (Millimeters)							Quantity/Unit		Unit Weight*
	A	B	C	D	E	F	G	Blower	Motor	
CXB02	38 (965)	17-1/8 (435)	10-7/16 (265)	3-1/4 (83)	34 (864)	5-3/4 (146)	11 (279)	1	1	100
CXB03	42 (1067)	21-1/2 (546)	10-1/4 (260)	3-1/4 (83)	38 (965)	5-3/4 (146)	11 (279)	1	1	120
CXB04	48 (1219)	25-7/8 (657)	11-1/16 (281)	3-1/2 (89)	44 (1118)	5-3/4 (146)	11 (279)	2	1	128
CXB06	53 (1346)	34-5/8 (879)	9-3/16 (233)	2-1/4 (57)	49 (1245)	6-3/4 (171)	12 (305)	2	1	170
CXB08	60 (1524)	39 (991)	10-1/2 (267)	2-1/4 (57)	56 (1422)	6-3/4 (171)	12 (305)	2	1	178
CXB10	74 (1880)	52-1/8 (1324)	10-15/16 (262)	2-1/2 (64)	70 (1778)	6-3/4 (171)	12 (305)	4	2	217
CXB12	82 (2083)	60-7/8 (1546)	10-9/16 (268)	2-1/2 (64)	78 (1981)	6-3/4 (171)	12 (305)	4	2	247

NOTES: * Unit weights (shown in pounds) are based on dry coils, minimum rows and exclude packaging, valves or other components.

1. RH shown, LH opposite.
2. All dimensions are +/- .25 (6). Drawing not to scale.
3. Product specifications are subject to change without notice.
4. Drip lip recommended. Provided when valve PKG is ordered.
5. Control box size and position may vary (consult factory).
6. Position may vary.
7. Service access is located on the front of the control box.
8. Knockouts on the bottom and side of the control box for incoming power connections.
9. Typical size 06 unit shown with 1-Motor and 2-BLWR - Refer to table for variation.
10. See Valve Package Supplemental for piping termination.
11. Field Connection Pipes will be shipped loose with valve packages.

Drawing is provided for reference only.
 Dimensions may vary with options ordered.
 Consult IEC website for submittal drawings.

Submittal Data, Cont'd.

Drain Pan Supplement

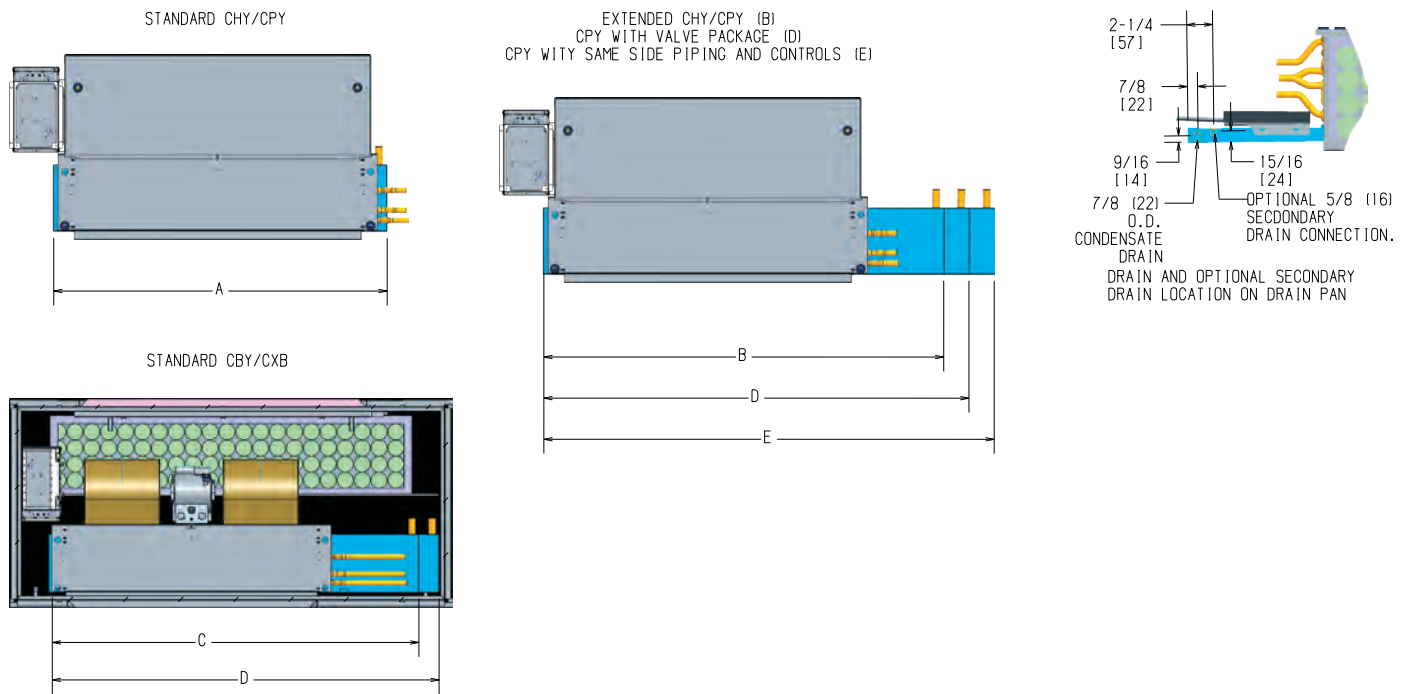

Unit Model	Dimensions - Inches (Millimeters)				
	A	B	C	D	E
	Standard CHY/CPY	Extended CHY/CPY (+7.25")	Standard CBY	Standard CXB (+10") Standard CPY w/VLV PKG	CPY Same Side Piping/ CNTRL w/VLV PKG (+12.75")
C**02	21-1/4 (540)	28-1/2 (724)	30-1/2 (775)	31-1/4 (794)	34 (864)
C**03	25-1/4 (641)	32-1/2 (826)	30-1/2 (775)	35-1/4 (895)	38 (965)
C**04	31-1/4 (794)	38-1/2 (826)	36-1/2 (927)	41-1/4 (1048)	44 (1118)
C**06	36-1/4 (921)	43-1/2 (1105)	48-1/2 (1232)	46-1/4 (1175)	49 (1245)
C**08	43-1/4 (1099)	50-1/2 (1283)	48-1/2 (1232)	53-1/4 (1353)	56 (1422)
C**10	57-1/4 (1454)	64-1/2 (1638)	70-1/2 (1790)	67-1/4 (1708)	70 (1778)
C**12	65-1/4 (1657)	72-1/2 (1842)	70-1/2 (1790)	75-1/4 (1911)	78 (1981)

Drawing is provided for reference only.
Dimensions may vary with options ordered.
Consult IEC website for submittal drawings.

Submittal Data, Cont'd.

Valve Package Supplement – CB/CX Units

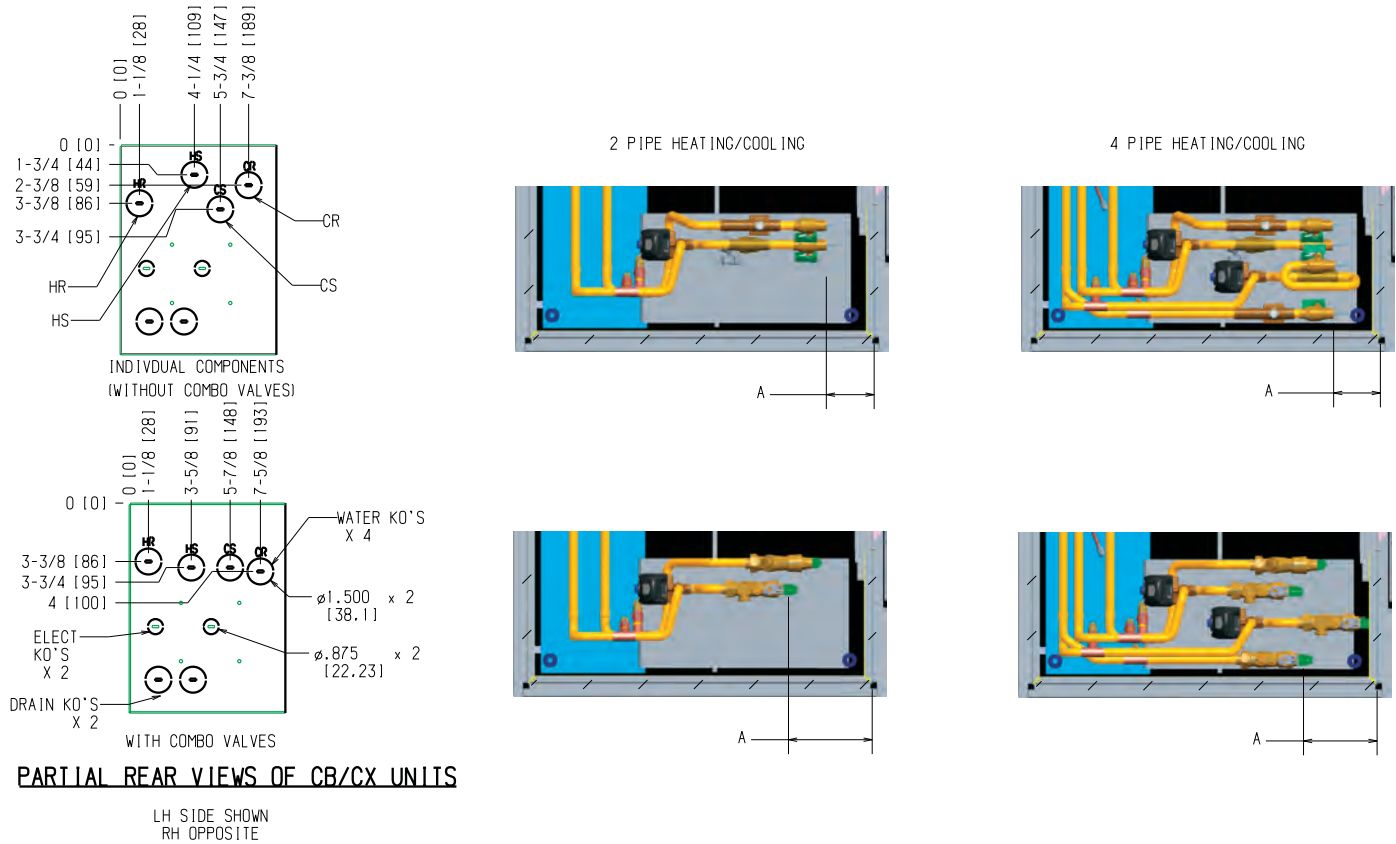

Dimensions - Inches (Millimeters)		
NO COMBO VALVES	A	
	SUPPLY	RET
3 WAY TACO/ERIE COOL	3-5/16 (84)	3-5/16 (84)
3 WAY TACO/ERIE HEAT	3-3/16 (81)	3-3/16 (81)
3 WAY MODULATING COOL	3-5/16 (84)	3-5/16 (84)
3 WAY MODULATING HEAT	3-1/8 (79)	1-5/8 (41)
2 WAY TACO/ERIE COOL	3-1/4 (83)	3-1/4 (83)
2 WAY TACO/ERIE HEAT	3-1/4 (83)	3-1/4 (83)
2 WAY MODULATING COOL	3-3/8 (86)	3-3/8 (86)
2 WAY MODULATING HEAT	3-3/16 (81)	1-1/4 (32)

Dimensions - Inches (Millimeters)		
COMBO VALVES	A	
	SUPPLY	RET
3 WAY TACO/ERIE COOL	5-1/8 (130)	6-1/4 (159)
3 WAY TACO/ERIE HEAT	1-1/2 (38)	3-3/16 (81)
3 WAY MODULATING COOL	3-1/4 (83)	4-7/16 (113)
3 WAY MODULATING HEAT	1-9/16 (40)	1-9/16 (40)
2 WAY TACO/ERIE COOL	4-1/8 (105)	5-3/4 (146)
2 WAY TACO/ERIE HEAT	13/16 (21)	5-1/8 (130)
2 WAY MODULATING COOL	4-3/8 (111)	3-1/4 (83)
2 WAY MODULATING HEAT	6 (152)	3-5/8 (92)

- NOTES:
- All dimension are $\pm 1/4"$ (6.3 mm).
 - Taco valves shown for reference only.
 - Component location and access may vary.
 - Coil stubout length may vary depending on unit size.

Drawing is provided for reference only.
 Dimensions may vary with options ordered.
 Consult IEC website for submittal drawings.

Submittal Data, Cont'd.

Valve Package Supplement – CB/CX Units

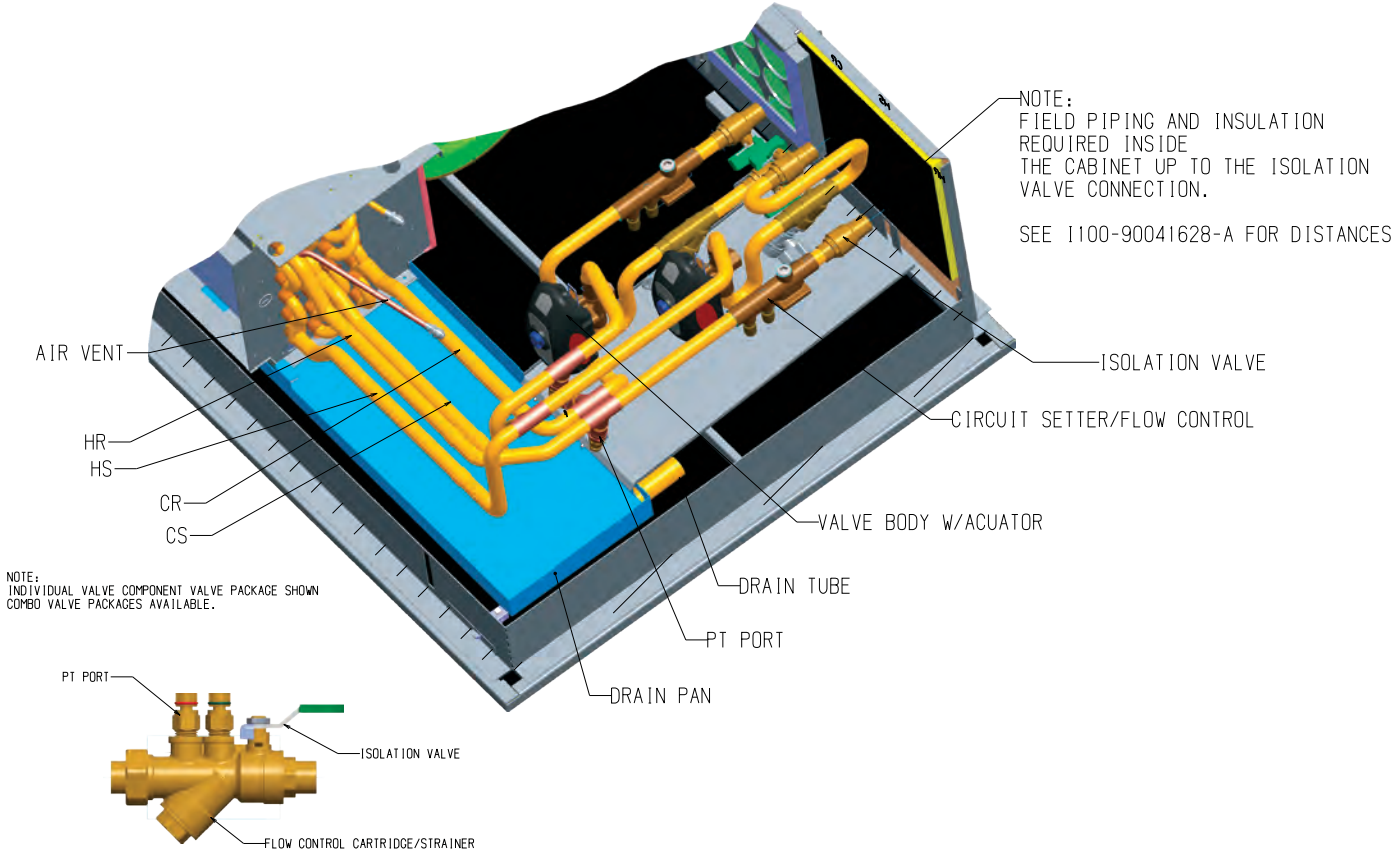

Drawing is provided for reference only.
 Dimensions may vary with options ordered.
 Consult IEC website for submittal drawings.

Submittal Data, Cont'd.

Valve Package Supplement – CP/CH Units

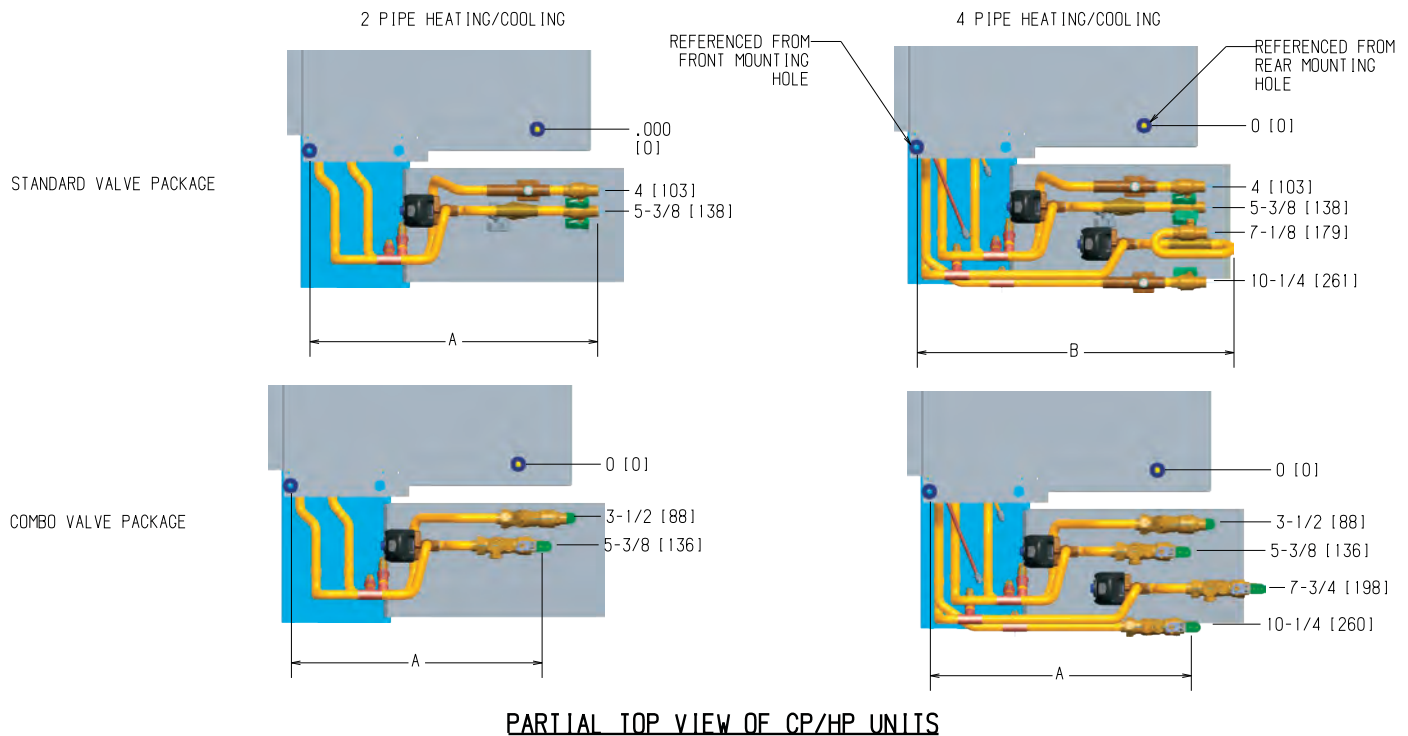

Dimensions - Inches (Millimeters)		
NO COMBO VALVES	A	B
	3 WAY TACO/ERIE COOL	19-1/8 (486)
3 WAY TACO/ERIE HEAT	19-1/4 (489)	21-1/8 (537)
3 WAY MODULATING COOL	19-1/8 (486)	
3 WAY MODULATING HEAT	19-1/4 (489)	21-9/16 (548)
2 WAY TACO/ERIE COOL	19-1/8 (486)	
2 WAY TACO/ERIE HEAT	19-1/4 (486)	21-1/8 (537)
2 WAY MODULATING COOL	19-1/8 (486)	
2 WAY MODULATING HEAT	21-1/8 (537)	21-9/16 (548)

Dimensions - Inches (Millimeters)		
COMBO VALVES	A	B
	SUPPLY / RETURN	
3 WAY TACO/ERIE COOL	17-5/16 (440) / 19-1/4 (489)	NA COMBO VLV CONNECTION DOES NOT EXCEED DISTANCE "A"
3 WAY TACO/ERIE HEAT	20-7/8 (530) / 19-1/4 (489)	
3 WAY MODULATING COOL	19-1/8 (486) / 18-1/16 (459)	
3 WAY MODULATING HEAT	20-7/8 (530) / 20-7/8 (530)	
2 WAY TACO/ERIE COOL	18-1/4 (464) / 16-5/8 (422)	
2 WAY TACO/ERIE HEAT	21-5/8 (549) / 17-3/8 (441)	
2 WAY MODULATING COOL	19-3-16 (487) / 16-5/8 (4220)	
2 WAY MODULATING HEAT	19-7/16 (494) / 18-13/16 (477)	

- NOTES:
1. All dimension are ± 1/4" (6.3 mm).
 2. Taco valves shown for reference only.
 3. Component location and access may vary.

Drawing is provided for reference only.
Dimensions may vary with options ordered.
Consult IEC website for submittal drawings.

Air Flow Arrangements

CPY – Horizontal Hideaway with Plenum

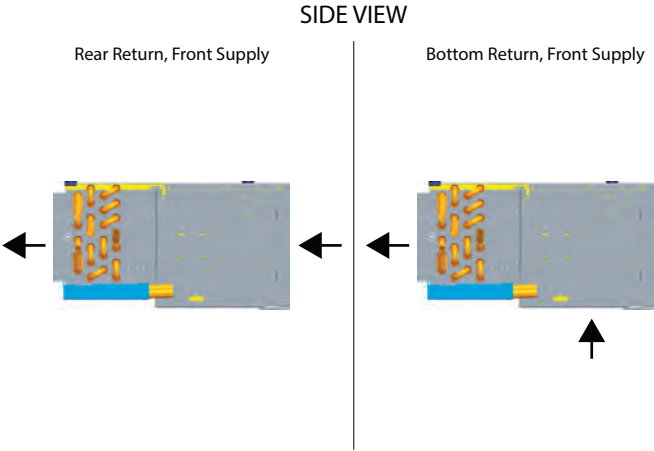
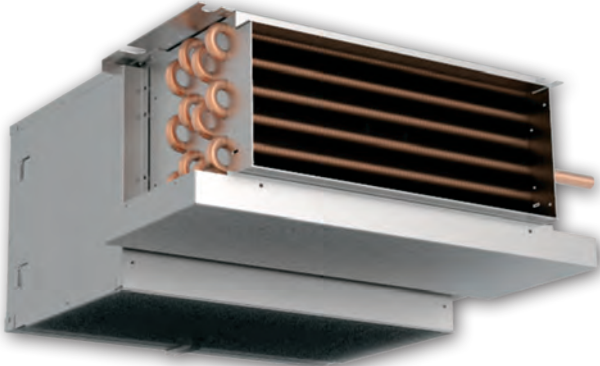

CXB – Horizontal Cabinet

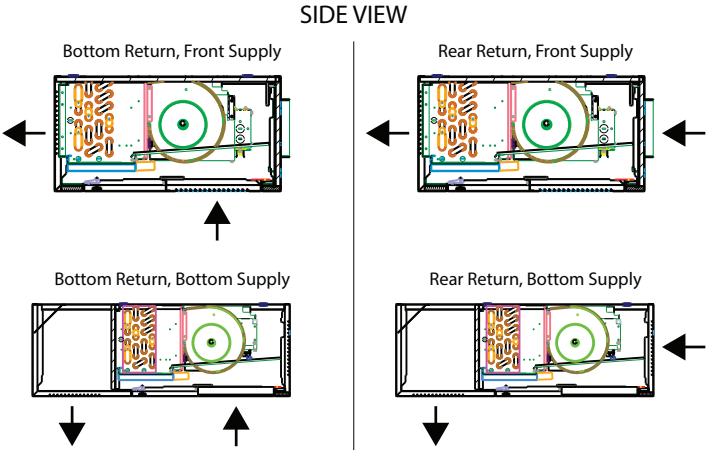

CHY – Horizontal Hideaway

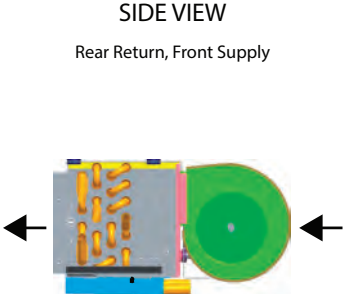
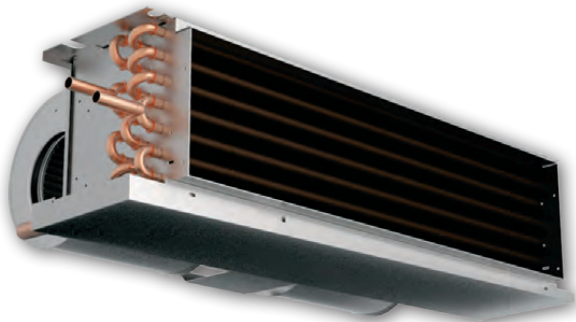

Air Flow Arrangements, Cont'd.

CBY – Horizontal Telescoping Hideaway

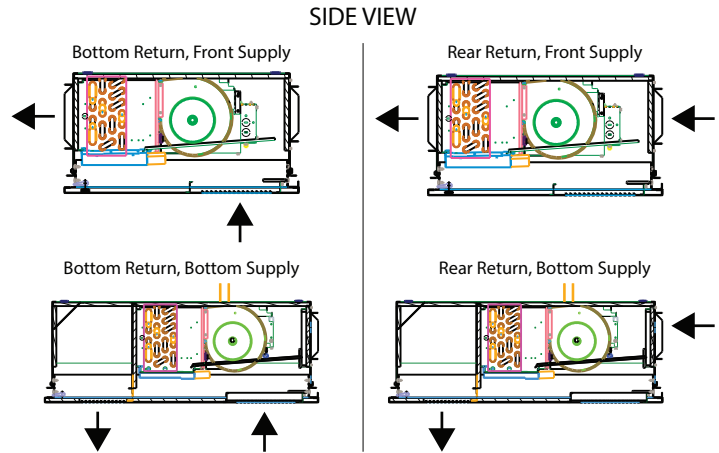

Standard Features and Options

Ceiling units are constructed with 18 gauge galvanized steel.

Features And Options	Standard	Factory Installed Option	Field Installed Option	Factory Special Quote
Air Flow Arrangement				
Front Supply/Rear Return (CHY)	X			
Front Supply/Rear Return(CPY, CXB, CBY)	X			
Front Supply/ Bottom Return (CPY, CXB, CBY)		X		
Bottom Supply/Bottom Return (CBY, CXB)		X		
Bottom Supply/Rear Return (CBY, CXB)		X		
Coils				
2 Rows 2-Pipe		X		
3 Rows 2-Pipe	X			
4 Rows 2-Pipe		X		
3/1, 3/2, 4/1 Rows 4-Pipe		X		
Manual Air Vent	X			
0.025" Tube Thickness				X
DX Cooling Coils		X		
Automatic Air Vent		X		
Steam Coils		X		X
Copper Coil Fins (2, 3, 4, 5 Rows)		X		
Coil Test Pressure 350	X			
Coil Test Pressure 400, 450		X		
Epoxy Coating		X		
Connection				
Right or Left (Same End)	X			
Right or Left (Opposite End)		X		
Removable Drain Pan				
Stainless Steel Externally Coated	X			
Drip Lip (recommended with motorized valves)			X	
Extended Drain Pans (CHY, CPY)		X		
Secondary Drain Connection		X		
Fin Material				
Aluminum with Galvanized End Sheets	X			
Copper with Stainless Steel End Sheets & Bottom Coil Baffle		X		X
Aluminum with Stainless Steel End Sheets		X		
Nichrome Wire Strip Electric Heater (Total and Auxiliary)				
		X		
Indoor Air Quality				
1" Throwaway non-woven synthetic filter (CPY, CXB, CBY)	X			
1" Permanent (CPY, CXB, CBY)		X		
1" Pleated MERV 8 (CPY, CXB, CBY)		X		
Bipolar Ionizer		X		
Side Filter Access (CPY)		X		
Insulation				
1/2" Standard Fiberglass	X			
1/2" Premium IAQ Fiberglass		X		X
1/2" Foil Face		X		
1/4" Closed Cell		X		

table continued on next page

Standard Features and Options, Cont'd.

Features And Options	Standard	Factory Installed Option	Field Installed Option	Factory Special Quote
Motor Type				
PSC Motors with Quick Connect Plug	X			
ECM Motors with Quick Connect		X		
Motor Voltage				
120/1/60 3-Speed	X			
208/230/277/1/60 3-Speed (Optional Voltage)		X		
Supply/Return Air Grilles				
Louvered Stamped Supply Grille (CXB)	X			
Double Deflection, Aluminum Finish Supply Grille		CXB	CHY, CPY, CBY	CHY, CPY, CBY
Double Deflection, Integral Supply Grille - painted		CXB		
Stamped Return Grille (CBY, CXB)	X			
Hinged Bar-Type, Aluminum-finish Return Grille with Throwaway Filter - F.O.			CHY, CPY, CBY	CHY, CPY, CBY
Paint Options (CBY, CXB)				
Arctic White	X			
Polar White, Flat Black, Ermine Gray, Champagne Beige, Toffee Brown		X		
Special Color				X
Controls				
Service Switch with Lockout Tabs		X		
Single Point Power Connection		X		
Incoming Power Fusing		X		
24V Controls		X		
Live Voltage Controls		X		
Condensate Float Switch		X		
3-Speed Switch		X	X	
Thermostats			X	
Custom Control (DDC)		X		X
Valve Package Options* (* Valve packages are assembled at the factory but field installed with exception of Valve Package Enclosure.)				
*Valve Package Enclosure - Rear Facing (CPY)		X		
Union Connections at the Coil			X	
24" Braided Hoses			X	
Ball Valves			X	
2-Way/3-Way 25 psi Control Valve			X	
2-Way/3-Way 150 psi, Normally Closed, Control Valve			X	
2-Way/3-Way 150 psi, Normally Open, Control Valve			X	
2-Way/3-Way 35 psi Floating Control Valve			X	
2-Way/3-Way 35 psi Proportional Control Valve			X	
Combination Supply/Return Valves			X	
Fixed Flow Control 1.0-8.0 GMP			X	
Y-Strainer/Y-Strainer with Blowdown			X	
P-T Ports			X	
Circuit Setter			X	
Balance Valve (Return Line)			X	
Balance Valve (3-Way Bypass)			X	

Standard Features and Options, Cont'd.

Nominal Filter Sizes

All cabinet model units (except CH) have non-woven synthetic throwaway filters furnished as standard equipment. Cleanable and pleated filters are optional.

Unit Size	Nominal One-Inch Filter Size - Inches (Millimeters)						
	CHY (Note 1)	CPY	CBY Bottom Return Stamped	CBY Rear Return	CXB Bottom Return Stamped	CXB Rear Return Stamped	CXB Rear Return Ducted
02	10" x 24" (254 x 610)	10" x 18" (254 x 457)	10" x 28" (254 x 711)	7" x 21" (178 x 533)	10" x 23-1/2" (254 x 597)	8-3/4" x 23-1/2" (222 x 597)	8-3/4" x 23-1/2" (222 x 597)
03	10" x 28" (254 x 711)	10" x 22" (254 x 559)	10" x 28" (254 x 711)	7" x 21" (178 x 533)	10" x 28" (254 x 711)	8-3/4" x 26-1/2" (222 x 673)	8-3/4" x 26-1/2" (222 x 673)
04	10" x 32" (254 x 813)	10" x 28" (254 x 711)	10" x 33" (254 x 838)	7" x 27" (178 x 686)	10" x 32-1/2" (254 x 826)	8-3/4" x 32-1/2" (222 x 826)	8-3/4" x 32-1/2" (222 x 826)
06	10" x 42" (254 x 1067)	10" x 33" (254 x 838)	10" x 45" (254 x 1143)	7" x 38" (178 x 965)	10" x 37" (254 x 940)	8-3/4" x 37" (222 x 940)	8-3/4" x 37" (222 x 940)
08	10" x 42" (254 x 1067)	10" x 40" (254 x 1016)	10" x 45" (254 x 1371)	7" x 38" (178 x 965)	10" x 41" (254 x 1041)	8-3/4" x 41" (222 x 1041)	8-3/4" x 41" (222 x 1041)
10	10" x 54" (254 x 1372)	10" x 54" (254 x 1372)	10" x 62" (254 x 1575)	7" x 52" (178 x 1321)	10" x 54-1/2" (254 x 1384)	8-3/4" x 54-1/2" (222 x 1384)	8-3/4" x 54-1/2" (222 x 1384)
12	10" x 64" (254 x 1626)	10" x 62" (254 x 1575)	10" x 62" (254 x 1575)	7" x 52" (178 x 1321)	10" x 63" (254 x 1600)	8-3/4" x 63" (222 x 1600)	8-3/4" x 63" (222 x 1600)

NOTES: 1. Filter sizes for the CH models are recommended filter sizes only. No filter is factory provided with these models.
2. Sizes shown are nominal ordering sizes.

Filter Static Resistance (in w.c.)

Unit Data		Filter Pressure Drop			
Model	Unit Size	Nominal CFM	1" Throwaway	1" Permanent	1" Merv 8
CPY	02	200	0.038	0.058	0.11
	03	300	0.046	0.078	0.13
	04	400	0.049	0.084	0.14
	06	600	0.060	0.121	0.16
	08	800	0.065	0.141	0.17
	10	1000	0.061	0.125	0.16
	12	1200	0.063	0.134	0.17
CBY	02	200	0.046	0.078	0.13
	03	300	0.066	0.145	0.18
	04	400	0.068	0.154	0.18
	06	600	0.072	0.171	0.19
	08	800	0.088	0.274	0.30
	10	1000	0.083	0.236	0.25
	12	1200	0.093	0.321	0.37

Unit Data		Filter Pressure Drop			
Model	Unit Size	Nominal CFM	1" Throwaway	1" Permanent	1" Merv 8
CXB	02	200	0.037	0.054	0.11
	03	300	0.046	0.076	0.13
	04	400	0.052	0.094	0.14
	06	600	0.066	0.144	0.17
	08	800	0.076	0.194	0.21
	10	1000	0.073	0.175	0.20
	12	1200	0.075	0.186	0.21

Standard Features and Options, Cont'd.

Bipolar Ionizer Specifications

SPECIFICATIONS:

Airflow Capacity: 2,400 CFM
 Pressure Drop: Less than 0.01 In. WG
 Housing Material: ABS
 Weight: 0.2 lbs.
 Maximum Operating Temperature: 200° F (93°C)
Electrical:
 Voltage: 24V AC (602)
 Power Consumptions: Less than 1 watt
 Frequency: 50/60 hertz
 Over Current Protection:.. 500mA Glass Cartridge Fuse
 Lead Wires 50"(L)

Ionization Output:

Mode of Operation Needlepoint Type
 Needle Configuration: Brush Type

DIMENSIONS: See Figure 1

APPROVALS: Intertek/ETL Standard UL 867

Figure 1. Dimensions not to scale.

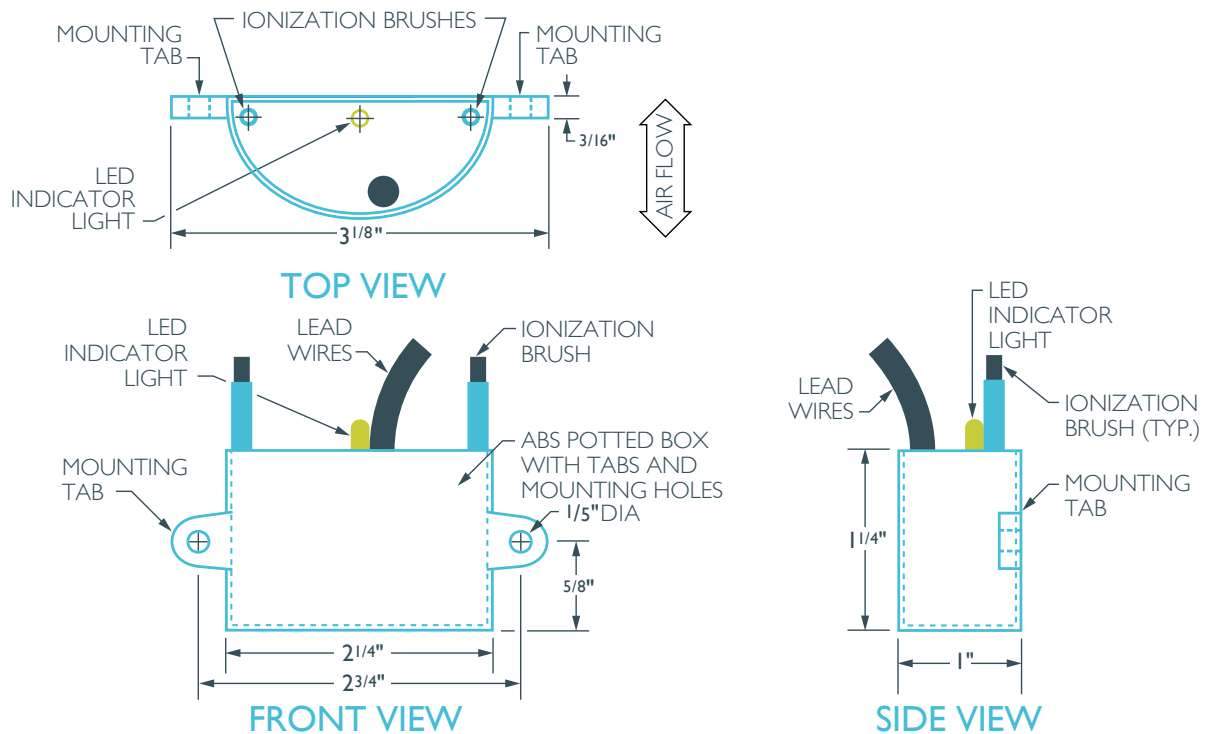

Standard Features and Options, Cont'd.

Control Packages

Controls

As detailed in the table below and on page 55, we offer control packages that fit most customer needs. Additional controls and devices are available to meet even the most demanding operating logic.

Low Voltage Control (24V)

The 85 Control Board (see page 58) offers simplified install and service with its plug-in connections and QR code for quick wiring diagram reference. It also offers LED diagnostics and built-in design flexibility for added features such as staged cooling or BAS signal input. The 85 Control board is available with most control schemes.

85 Control Board Standard Features

- Simplified plug connections
- PSC or ECM control
- LED diagnostics (See IOM-100 for detailed LED function and outcome)
- QR code to wire diagram for ease of troubleshooting
- Conduit compatible for remote mounted control boxes
- Compatibility with all actuator types
- Removable thermostat connector

85 Control Board Options

- ECM fan speed adjustment
- Staged Cooling: compatible with IEC Venture Wi-Fi Thermostat (E055 - 1520330)
- BAS signal input to interrupt fan and actuators
- Fusing and service switch with electric heat
- Changeover or aquastat sensor
- Condensate switch LED indication
- Damper control

Condensate Float Switch

This switch shuts down the motor, actuator and electric heat (if applicable) when the water level in the drain pan reaches an unsafe level.

Service Switches

We offer concealed service switches for use by maintenance and service personnel to shut off the power while working on the unit.

Fusing

We offer incoming power fusing for all units as well as blower motor and control sub-fusing (single power source wiring).

Other Control Options

- Unit mounted 3-speed switch (thermostat by others)
- 4-Speed silent switching board with potentiometers
- Low voltage remote shutdown relays (Special Quote)
- Fan and valve cycle applications (Special Quote)
- Thermostats available with large letter print for handicap applications (Special Quote)

Standard Features and Options, Cont'd.

Controls Packages, Cont'd.

85 Control Board

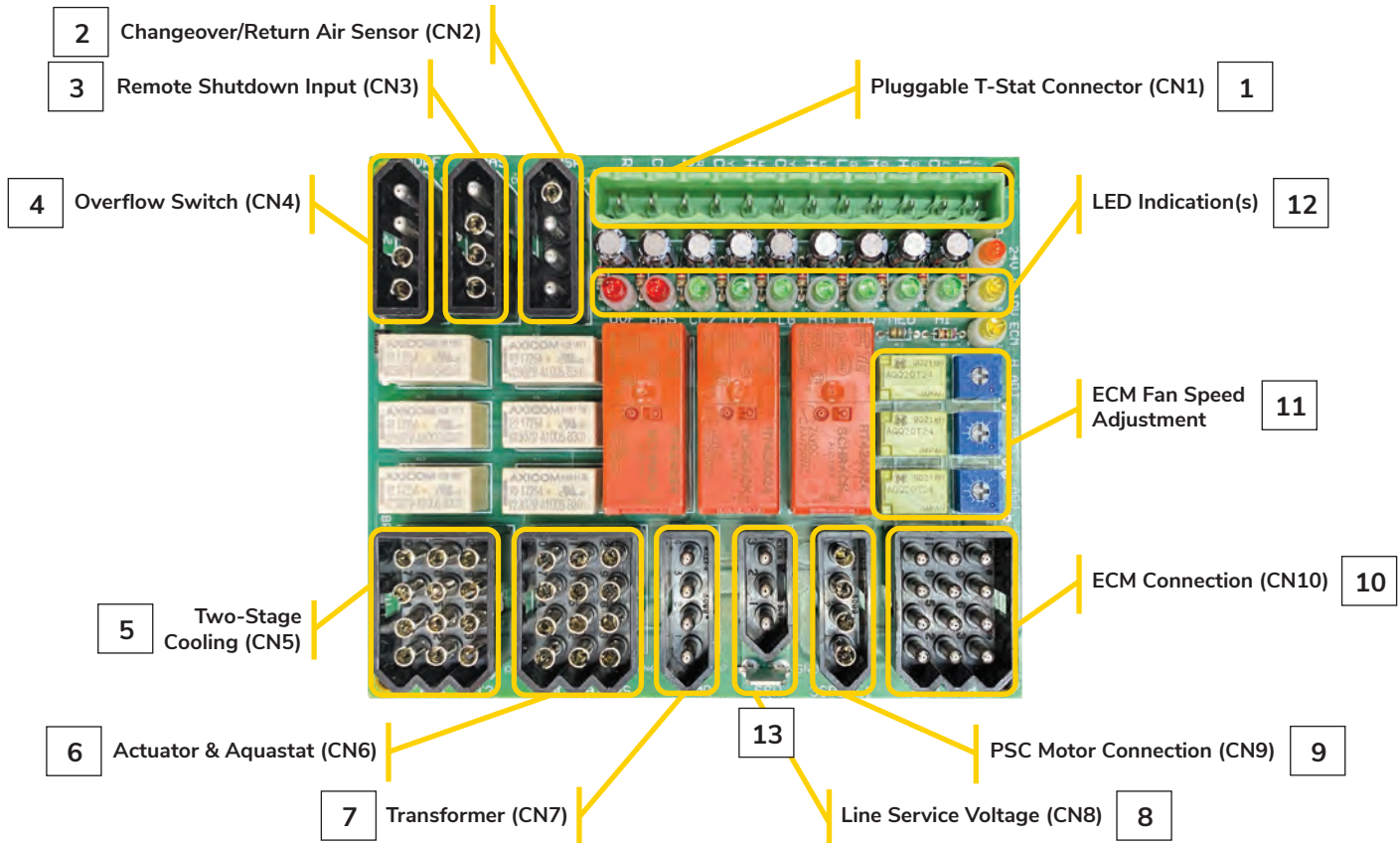

1	CN1 – 24V Customer Input (Thermostat)
2	CN2 – Changeover/Return Air Sensor
3	CN3 – Remote Shutdown Input
4	CN4 – Condensate Overflow Switch
5	CN5 – Two Stage Cooling
6	CN6 – Actuator & Aquastat
7	CN7 – Transformer
8	CN8 – Line Service Voltage
9	CN9 – PSC Motor Connection
10	CN10 – ECM Connection
11	ECM Fan Speed Adjustment
12	LED Diagnostics
13	Ground Connection

Standard Features and Options, Cont'd.

Thermostat Control Package Applications

Unit Type	Control Option	System Type	Changeover Type	W	P	N	F	G	A	B	
-	Manual Fan	Manual ¹	None	-	-	-	-	-	-	-	
2-Pipe	Valve Cycle	Heat Only	None	•	•	•	•	•	•	•	
		Cool Only	None	•	•	•	•	•	•	•	
		Heat/Cool	Manual	-	-	-	-	-	-	•	•
			Automatic	•	•	•	•	•	•	•	•
		Heat/Cool with Auxiliary Electric Heat	Manual	-	-	-	-	-	-	•	•
			Automatic	•	•	•	•	•	•	•	•
Cool with Total Electric Heat	Manual	-	-	-	-	-	-	•	•		
	Automatic	•	•	•	•	•	•	•	•		
4-Pipe		Heat/Cool	Manual	-	-	-	-	-	•	•	
			Automatic	•	•	•	•	•	•	•	

NOTES: 1. Fan switch only; no thermostat.

Thermostat Features

All listed controls include fan switching.	Control Type ¹						
	W	P	N	F	G	A	B
24V, 115V, 208V, 240V, 277V	24V only	24V only	24V only	24V only	24V only	•	•
Wi-Fi Enabled	•	-	-	-	-	-	-
Mobile and Web App for Remote Control	•	-	-	-	-	-	-
Staged Cooling	•	-	-	-	-	-	-
Programmable	•	•	-	•	-	-	-
Remote Wall Mounted	•	•	•	•	•	•	•
Manual Fan Switch Operation	•	•	•	•	•	•	•
Auto Fan Speed Control	•	•	•	•	•	-	-
Continuous 3-Speed Fan	•	•	•	•	•	•	•
Cycling Fan	•	•	•	•	•	•	•
O.A Damper Signal	•	•	•	•	•	-	-
Remote Temperature Sensor	Opt	Opt	Opt	Opt	Opt	•	•
Digital Display & Buttons	•	•	•	•	•	-	-
Local Temperature Set-Back	•	•	•	•	•	-	-
Water Temperature Purge Cycle	•	•	•	•	•	-	-
Proportional Control Valves	-	-	-	•	•	-	-
Floating Control Valves	-	-	-	•	•	-	-
Pipe Sensor	•	•	•	•	•	-	-

NOTES: 1. Control packages with valve cycle are continuous fan operation only.
 2. All wall-mounted control packages are shipped loose for field installation (Boxes, tile rings, plaster rings, etc. are not provided.).
 3. Aquastats are included in control packages, as required.

LEGEND: A • Basic Electronic Wall Series, 155, Vertical
 B • Basic Electronic Wall Series, 155, Horizontal
 P • Basic 24 V Digital, 7-Day Programmable
 N • Basic 24 V Digital, Non-Programmable
 F • Premium 24 V Digital, 7-Day Programmable
 G • Premium 24 V Digital BACnet with Proportional Fan/Valves Option
 W • Venture 24 V Wi-Fi Programmable

Standard Features and Options, Cont'd.



Venture 24V,
Wi-Fi Programmable



Basic 24V Digital
7-Day Programmable and
Non-Programmable Series



Premium 24V Digital
7-Day Programmable/BACnet

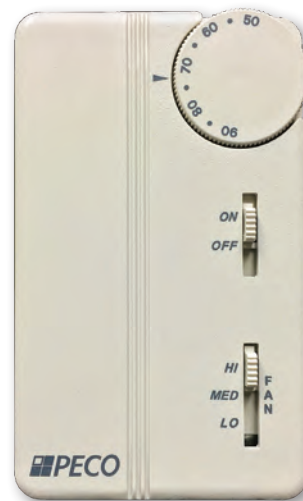

Basic Electronic Wall Series
155, Vertical and Horizontal



Basic Series, 156,
Unit Mounted

Standard Features and Options, Cont'd.

Supply Air Grilles

Unit Size	Nominal CFM	Recommended Grille Size - Inches (Millimeters)
02	200	16" x 6" (406 x 152)
03	300	20" x 6" (508 x 152)
04	400	26" x 6" (660 x 152)
06	600	30" x 6" (762 x 152)
08	800	38" x 6" (965 x 152)
10	1000	52" x 6" (1320 x 152)
12	1200	60" x 6" (1524 x 152)

NOTES: 1. Refer to Submittal Data pages for actual unit supply air opening dimensions.
2. Field-furnished duct transitions may be required.

Return Air Filter Grilles

Unit Size	Nominal CFM	Recommended Grille Size - Inches (Millimeters)
02	200	24" x 10" (610 x 254)
03	300	28" x 10" (711 x 254)
04	400	32" x 10" (813 x 254)
06	600	42" x 10" (1067 x 254)
08	800	42" x 10" (1067 x 254)
10	1000	54" x 10" (1372 x 254)
12	1200	64" x 10" (1626 x 254)

NOTES: 1. Refer to Submittal Data pages for actual unit supply air opening dimensions.
2. Field-furnished duct transitions may be required.

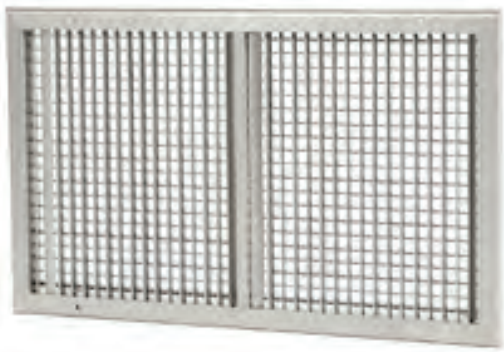

Optional Double Deflection, Aluminum-finish Supply Grille
(Optional special ship separate for models CHY, CPY, and CBY. Consult factory for details.)



Optional Hinged, Bar-type, Aluminum-finish Return Grille with Throwaway Filter
(Optional special ship separate for models CHY, CPY, and CBY. Consult factory for details.)



Optional Double-deflection, Integral Supply Grille
Painted to Match Color of Unit

Piping Packages (Typical)

Two-way Motorized Control Valve

In a two-way motorized control valve package, the motor drives the valve open, and a spring returns the valve to a normally closed position. No water flows with the unit off. The standard supply connection from the coil will accept a swaged copper fitting for field brazing. As an option, this connection may be factory furnished with a union. When a swage is necessary, it becomes part of the valve package. The isolation, or ball, valve in the return piping is shipped loose for field installation.

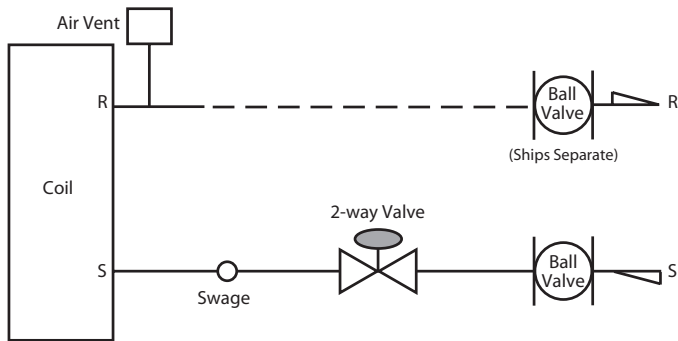

Three-way Motorized Control Valve

In a three-way motorized control valve package, a diverting valve controls water flow to the coil. When the unit is off, water bypasses the coil and flows directly to the system return. A balancing valve may be specified in the bypass line to permit equal flow balancing.

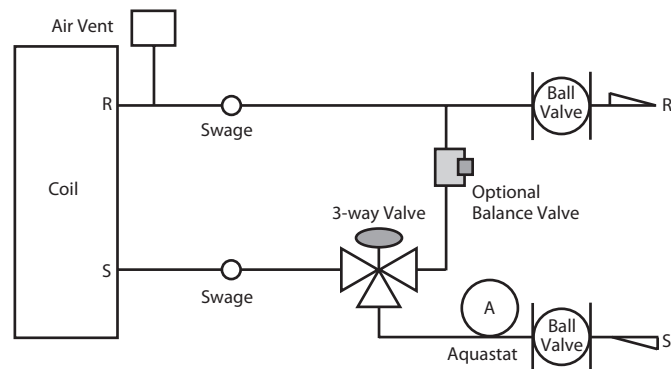

Two-way Motorized Control Valve with Changeover

In a two-way motorized changeover control valve package, the motor drives the valve open, and a spring returns the valve to a normally closed position. No water flows through the coil with the unit off. The aquastat bypass line allows a small amount of water to flow from the supply to the return piping when the control valve is closed. The strap-on aquastat senses whether the flowing water is cold or hot and switches a contact closed to provide automatic summer/winter changeover (ACO) for the system.

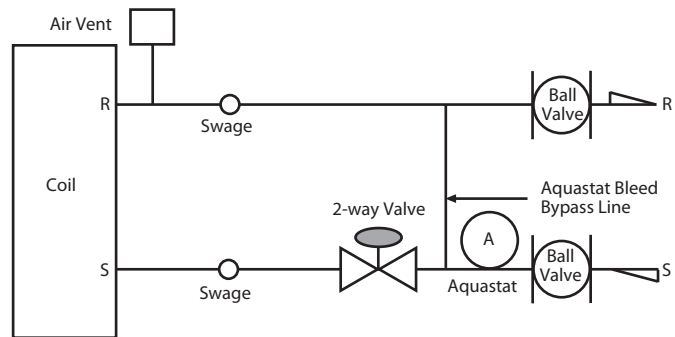

- NOTES:**
1. Please note that project specifications for system pressure, pressure drop limitations and flow rate should be checked prior to selecting specific components or the valve package size
 2. The supply and return piping connections of the factory-provided valve package are either swaged for field brazing (standard) or union fitted (optional) for field connection to the coil.
 3. Consult IEC's Valve Packages and Piping Components manual or your local representative for detailed piping and valve application information. Factory-provided valve packages are assembled, brazed, wired electrically and dry-fit to the coil connections before shipping. Field brazing to the coil completes the installation. Some applications dictate shipping isolation valves loose.

This page intentionally left blank.

This page intentionally left blank.

This page intentionally left blank.

Horizontal Series

FAN COIL TECHNICAL CATALOG



Contact your local IEC Sales Representative for further details and pricing applicable to this product. Visit our website (iec-okc.com) to find your local IEC Sales Rep.

IEC Part Number: I100-9002102
CA-020 Revision 18.1 (11/2022)

©2000-2022 International Environmental Corporation (IEC)



5000 W. I-40 Service Rd.
Oklahoma City, OK 73128
P: 405.605.5000
F: 405.605.5001
www.iec-okc.com