

EZ42 SERIES

THRU-THE-WALL/BUILT-IN AIR CONDITIONERS

PRODUCT INFORMATION



Two-stage electric heat for energy savings!!



The EZ42 Series units are designed and manufactured for new construction or the replacement of existing Amana, GE, LG, Friedrich, Gree, Trane and all other 42" by 16" PTACs & PTHPs. The product is designed for individually-zoned, comfort-controlled heating and cooling. The unit width is an industry standard 42". We offer our cooling chassis to operate with cooling only or heat pump with back up electric heat, or just straight electric heat. The design standards, heavy duty construction and the focus on indoor noise reduction has created our unit as the premier unit of the future. Standard warranty is a one year parts and labor including five year sealed system part only warranty or a two year parts only including a five year sealed system part only warranty.

FEATURES:

- Dual fan motors
- Quiet and energy-efficient compressor
- Superior temperature control
- Conventional thermostat compatible for heat pump applications
- Modern and elegant appearance
- Washable filter for easy cleaning
- User friendly control panel, remote controller and wall thermostat
- Compressor freeze protection
- Manual fresh air damper
- Random start-up delay after power failure
- Room side freeze protection (optional)
- On-board Diagnostics

ACCESSORIES:

- 1/8 gauge insulated wall sleeve
- Condensate removal kit
- Architectural louver
- Sub-base kit
- Electrical sub-base kit
- Wired remote thermostat
- Wireless remote thermostat
- I.R. motion sensor
- Door switch
- Duct kit
- Locking control cover

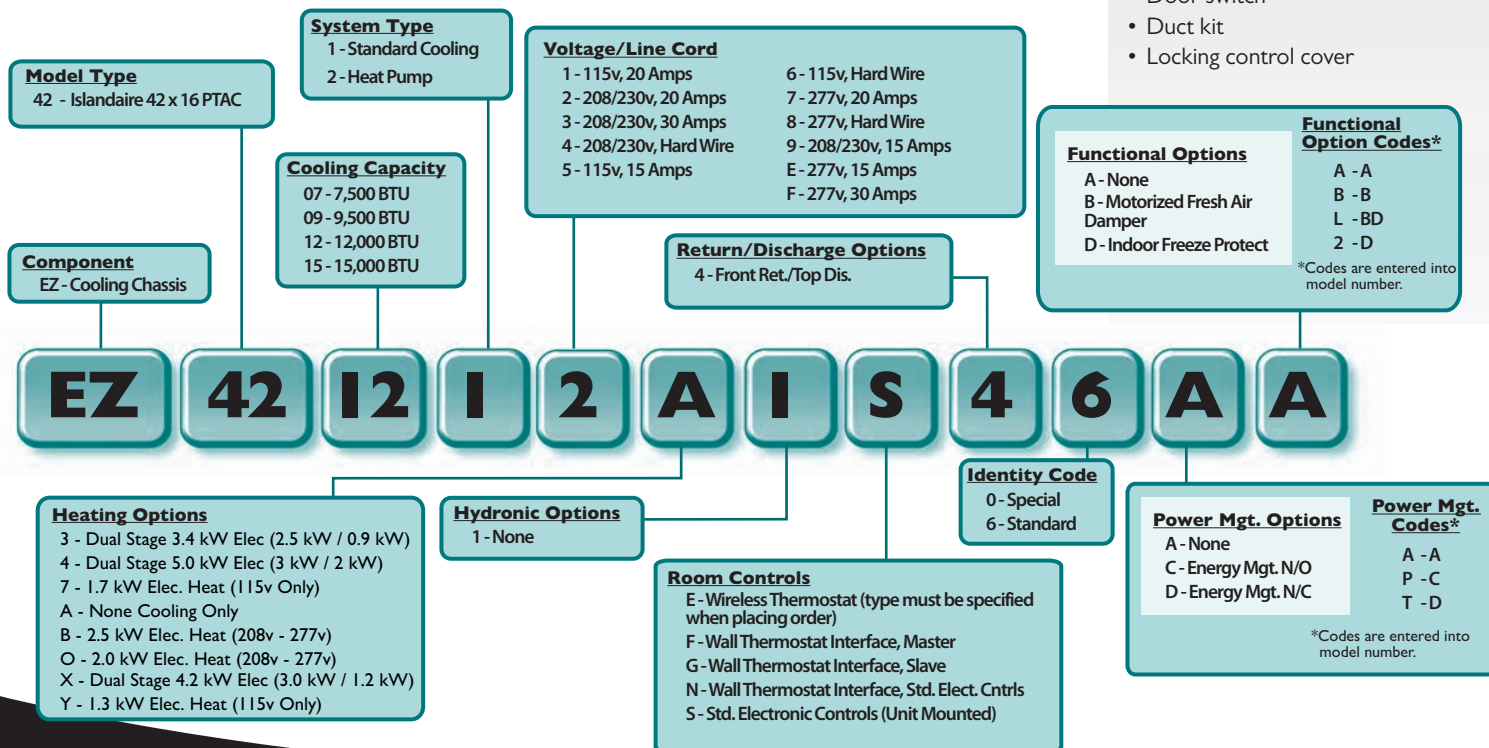

500 Middle Country Road, St. James, NY 11780 • 1-800-886-2759

e-mail: sales@islandaire.com • www.islandaire.com

Ph: 631-471-2900 • Fax: 631-471-2913

6140308 Rev. 11/28/23

EZ42 SERIES

THRU-THE-WALL/BUILT-IN AIR CONDITIONERS

PRODUCT INFORMATION



MODELS											
	EZ07			EZ09			EZ12			EZ15	
VOLTS	115	208 / 230	277	115	208 / 230	277	115	208 / 230	277	208 / 230	277
BTUH COOL	7200	6,800 / 7,200	7,200	9,800	9,300 / 9,500	9,500	12,500	12,300 / 12,500	12,500	14,300 / 14,500	15,000
AMPS COOL	4.91	2.52 / 2.46	2.11	7.22	3.70 / 3.41	2.83	9.30	5.05 / 4.65	3.86	6.49 / 5.96	5.20
WATTS COOL	565	525 / 565	585	830	770 / 785	785	1,070	1,050 / 1,070	1,070	1,350 / 1,370	1,440
EER	12.8	13.0 / 12.8	12.3	11.8	12.1 / 12.1	12.1	11.7	11.7 / 11.7	11.7	10.6 / 10.6	10.4
CFM HIGH COOL CFM (m3/min)	340 (9.6)	340 (9.6) / 375 (10.6)	360 (10.2)	340 (9.6)	340 (9.6) / 375 (10.6)	360 (10.2)	340 (9.6)	340 (9.6) / 375 (10.6)	360 (10.2)	360 (10.2) / 360 (10.2)	360 (10.2)
LOW COOL/HEAT CFM (m3/min)	240 (6.8)	240 (6.8) / 260 (7.4)	260 (7.4)	240 (6.8)	240 (6.8) / 260 (7.4)	260 (7.4)	240 (6.8)	240 (6.8) / 260 (7.4)	260 (7.4)	240 (6.8) / 260 (7.4)	260 (7.4)
BTUH HEAT	6400	6,300 / 6,400	6,100	8,500	8,300 / 8,500	8,500	11,400	11,000 / 11,400	11,400	13,200 / 13,600	14,000
WATTS HEAT	530	520 / 530	520	710	685 / 710	710	980	915 / 950	980	1,150 / 1,180	1,300
C.O.P.	3.5	3.6 / 3.5	3.4	3.51	3.6 / 3.5	3.51	3.4	3.5 / 3.5	3.4	3.4 / 3.4	3.16
NOISE (DBA) INDOOR/OUTDOOR	45/69	45/69	45/69	45/69	45/69	45/69	45/69	45/69	45/69	45/69	45/69
SHIPPING WEIGHT LB. (kg)	116 (52.6)	116 (52.6)	116 (52.6)	116 (52.6)	116 (52.6)	116 (52.6)	116 (52.6)	116 (52.6)	116 (52.6)	112 (52.6)	119 (54.0)

EZ42 Documentation List:

P/N	Document Title
6140165	Instructions, Drain Kit Installation
6140432	Manual, EZ42/EZDR Installation/Owners
6140507	Manual, EZ42/EZDR Engineering

Line Voltage	Maximum Amperage	Wall Socket Configuration	Receptacle Number	Electrical Heat Options
115	12		NEMA 5-15R	1.3
115	16		NEMA 5-20R	1.7
208/230	12		NEMA 6-15R	2.0 - 2.5
208/230	16		NEMA 6-20R	3.4
208/230	24		NEMA 6-30R	4.2 - 5.0
277	16		NEMA 7-20R	2.0 - 4.2
277	24		NEMA 7-30R	5.0

Where applicable, cooling capacities are specified at conditions of 95 °F DB/75 °F WB (35 °C DB/24 °C WB) outdoor and 80 °F DB/67 °F WB (27 °C DB/19 °C WB) indoor and heating capacities are specified at conditions of 47 °F DB/43 °F WB (8 °C DB/6 °C WB) outdoor and 70 °F DB/60 °F WB (21 °C DB/16 °C WB) indoor in accordance with AHRI 310/380 and CSA C744 standards. Wattage, Amperage, EER, and COP listings include compressor, evaporator motor and condenser fan motor. The above ratings are a typical heat pump style unit.

Heating Option	Voltage ⁽¹⁾	Wattage	BTU/h	Amps ⁽²⁾
3	208	2,780	9,500	13.37
	230	3,400	11,600	14.78
	277	3,400	11,600	12.27
4	208	4,090	14,000	19.66
	230	5,000	17,100	21.74
	277	5,000	17,100	18.05
7	115	1,700	5,800	14.78
	208	1,635	5,600	7.87
	230	2,000	6,800	8.70
O	277	2,000	6,800	7.22
	208	2,045	7,000	9.83
	230	2,500	8,500	10.87
B	277	2,500	8,500	9.03
	208	3,435	11,700	16.51
	230	4,200	14,300	18.26
X	277	4,200	14,300	15.16
	Y	115	1,300	4,400

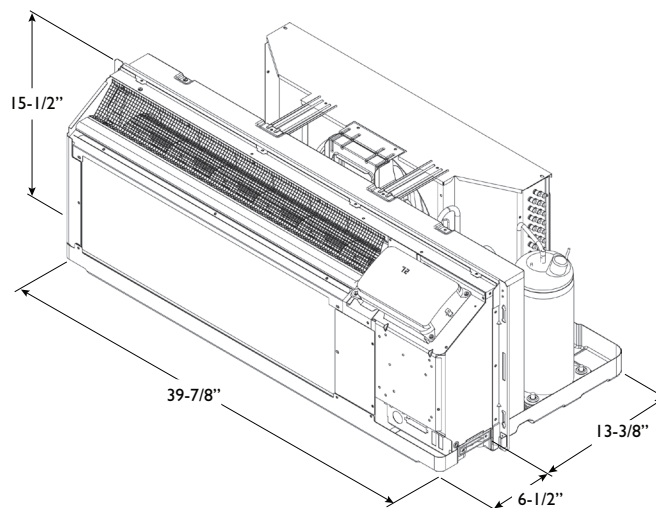

⁽¹⁾ Voltage is Single Phase, Alternating Current and R.M.S.
⁽²⁾ Amp values are for heater element only.

*Islandaire has a policy of continuous improvement of its products and reserves the right to change the materials and specifications without notice.

EZ42 SERIES

THRU-THE-WALL/BUILT-IN AIR CONDITIONERS

PRODUCT INFORMATION

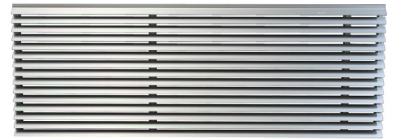
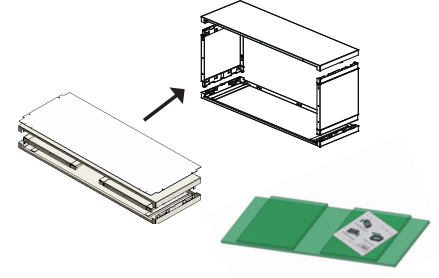

WALL SLEEVES					
PART NUMBER	DESCRIPTION	APPROX. WT.	DIMENSIONS		
			DEPTH	WIDTH	HEIGHT
Consult Factory	Custom Wall Sleeves available for all building types/wall thicknesses	-	-	-	-
2400405-00	EZ42 Wall Sleeve, Recessed Louver	34.0 lb.	15.00"	42.00"	16.00"
2401135-00	EZ42 Wall Sleeve Assembly, Break Down	33.0 lb.	13.75"	42.00"	16.00"
1090339-00	EZ42 Wall Sleeve Extension Kit	5.0 lb.	2.000"	42.00"	16.00"
1092502	Kit, Acoustic Insulation for Sleeve 2401135-00	1.35 lb.	1.000"	40.375"	13.000"

DUCT ASSEMBLIES					
PART NUMBER	DESCRIPTION	APPROX. WT.	DIMENSIONS		
			DEPTH	WIDTH	HEIGHT
4082401-00	EZ42 Duct Assembly, Standard w/ Plenum	20.0 lb.	N/A	N/A	N/A
4082404-00	EZ42 Duct Extension, 3'	10.0 lb.	N/A	N/A	N/A
6070199	EZ42 Duct End Grille, 6" x 6"	5.0 lb.	N/A	N/A	N/A

LOUVERS					
PART NUMBER	DESCRIPTION	APPROX. WT.	DIMENSIONS		
			DEPTH	WIDTH	HEIGHT
6070264	EZ42 Stamped Louver, Formed, Standard (use with 2401135-00 wall sleeve)	5.0 lb.	1.063"	41.00"	15.50"
6070422	EZ42 Architectural Louver, External, Standard (use with 2401135-00 wall sleeve)	7.0 lb.	1.125"	42.00"	15.90"
6070134	EZ42 Louver, Recessed (use with 2400405-00 wall sleeve)	7.0 lb.	1.125"	41.50"	15.50"

THERMOSTATS					
PART NUMBER	DESCRIPTION	APPROX. WT.	FEATURES		
			CONNECTION	STAGE	DISPLAY
6041206	Islandaire Non-Programmable, Two Fan Speed	1.0 lb.	Wireless	Single	Horizontal
6041210	Islandaire Programmable, Two Fan Speed	1.0 lb.	Wireless	Single	Horizontal
6041228	Islandaire Programmable (7 Day/5-1-1 Day/ Non-Programmable), 2-Fan Spd	1.0 lb.	Wired	Single	Horizontal

FILTERS					
PART NUMBER	DESCRIPTION	APPROX. WT.	DIMENSIONS		
			DEPTH	WIDTH	HEIGHT
6080067	EZ42 Plastic Filter (2 Pieces), Standard	2.0 lb.	N/A	N/A	N/A

SUBBASES					
PART NUMBER	DESCRIPTION	APPROX. WT.	FEATURES		
			VOLTAGE	AMPERES	HEIGHT
4083349	EZSB4203EMR12S00F00V00	14.5 lb.	208/230v	15/20A	3.00"
4083350	EZSB4203EMR13S00F00V00	15.0 lb.	208/230v	30A	3.00"
4083351	EZSB4203EMR15S00F00V00	13.0 lb.	265/277v	20A	3.00"
4083352	EZSB4203BPR00S00F00V00	13.0 lb.	N/A	N/A	3.00"
4083200	EZSB4204EMR12S00F20V00	13.0 lb.	208/230v	15/20A	4.00"
4084008	EZSB4205EMR12S00F00V00	13.0 lb.	208/230v	15/20A	5.00"

OTHER OPTIONS			
PART NUMBER	DESCRIPTION	APPROX. WT.	FEATURES
4090345	EZ42 Louver Hardware Kit #10-32	1.0 lb.	-
4090661	EZ42 External/Internal Drain Kit	1.0 lb.	-
4090970	EZ42 Stamped Louver Hardware Kit	1.0 lb.	-
4091104	EZ42 Air Deflector Kit, Standard	5.0 lb.	-
6041146	EZ42 Hand Held Remote Replacement	1.5 lb.	-
6130133	EZ42 Front Panel (Plastic)	10.0 lb.	-

Ask your salesman about our
DR. VTAC option!*



*100% conditioned
fresh air

Vertical Unit Available

For New Construction and as
Replacement for:

**GE AZ Vertical and
Friedrich Vert-I-Pak**



500 Middle Country Road • St. James, NY 11780 • 1-800-886-2759
e-mail: sales@islandaire.com • www.islandaire.com
Ph: 631-471-2900 • Fax: 631-471-2913



Locally Represented By: