

# **199 Series**

---



## **USER MANUAL FOR THE METRO C199 AND FL199 SERIES INSULATED HEATED CABINETS**

**Recommended Food Holding  
Guidelines Listed on pages 5 & 6.**



**InterMetro Industries Corporation**  
Wilkes-Barre, PA 18705  
570-825-2741

---



# TABLE OF CONTENTS

SECTION	PAGE
<b>I. Introduction</b>	
A. Identifying Your Cabinet .....	1
B. Features .....	2
<b>II. Operating Instructions</b>	
A. Reversible Doors .....	2
B. Slide Rack Assemblies .....	2
C1. HM2000 Holding Module .....	3
C2. FL2000 High Humidity Holding .....	4
<b>III. Food Holding Guidelines</b>	
A. HM2000/HM15LW Recommended Food Holding Guidelines .....	5 & 6
<b>IV. Cleaning Instructions</b>	
A. Specific Cleaning Instructions .....	7
B. General Cleaning Instructions .....	7
<b>V. Maintenance</b>	
A. Cabinet Maintenance .....	7
B. Module Maintenance .....	7
C. Blower Motor Maintenance .....	7
<b>VI. Replacement Parts, Procedures and Wiring Diagrams</b>	
A. Cabinet .....	8 & 9
B. Modules .....	10
<b>HM2000</b>	
Module Replacement Parts Diagram .....	11
Wiring Schematic .....	12
<b>FL2000</b>	
Module Replacement Parts Diagram .....	13
Wiring Schematic .....	14

## I. INTRODUCTION

### A. IDENTIFYING YOUR CABINET

Your cabinet assembly has been shipped in two cartons. The first carton contains the cabinet with module. The other carton contains the slide racks.

There are several component numbers which you may want to record for future reference: the cabinet model number, the module model number along with the module serial number and the slide rack model number. Refer to the photo at right to locate these numbers. The slide rack model number is located on the label affixed to the ends of the rack carton. It is recommended that all numbers be recorded in an appropriate place, such as at the bottom of this page. Also, please record the cabinet model number and module serial number on the Warranty Card found at the back of this manual. Be sure to complete the remainder of the Warranty Card and return it to Metro within fifteen (15) days of delivery of the cabinet. Once you have located and recorded these numbers, refer to the sample numbers given on this page to identify the components of your 199 series cabinet.

Cabinet Model No. \_\_\_\_\_

Module Model No. \_\_\_\_\_

Module Serial No. \_\_\_\_\_

Slide Rack Model No. \_\_\_\_\_

## SAMPLE OF CABINET LABELING

C199-HM2000 = Full Height, Holding

C199T-HM2000 = 3/4 Height, Holding

**OR**

FL199-HM2000 = Full Height, High Humidity Holding

FL199H-HM2000 = 1/2 Height, High Humidity Holding

## SAMPLE OF SLIDE RACK CARTON LABELING

C4SC = Full Height

C4SC-T = 3/4 Height

C4SC-H = 1/2 Height

└─ Indicates Slide Spacing

C4SC/-T/-H = Wire 3" Spacing

C8SN/-T/-H = Aluminum Fixed on 1 1/2" Spacing

CVSN/-T/-H = Aluminum Adjustable



**NOTE:** Please read this manual thoroughly before using your cabinet. If you should have questions, please contact Metro customer service department.

## B. FEATURES — ALL MODELS

In order to utilize your new cabinet to its full potential, take a minute to identify the following features which have been provided for your convenience.

- The module has been placed at the base of the cabinet for easy accessibility and efficient operation.
- Clearly-marked control panel for easy viewing and allowing climate adjustments without opening the door(s).
- Removable water pan (C199) or water bottle (FL199).
- Rear pan stop.
- Field reversible insulated and gasketed door(s).
- Easy pull adjustable magnetic door latch.
- Cord keeper at rear of cabinet which folds flat to prevent damage to surrounding walls.
- All components — door(s), module, chimney, slide racks — removable to permit thorough, obstruction-free cleaning.

## II. OPERATING INSTRUCTIONS

### A. REVERSIBLE DOOR(S)

The door(s) on your cabinet can be reversed to accommodate a right- or left-hand opening. The cabinet has been shipped with the hinges mounted on the right-hand side. To reverse, follow the instructions listed below (read completely before starting procedure):

1. With the doors in the closed position remove the hinge pin by driving it out using a hammer and a drive pin or small diameter screwdriver.
2. Once the pins are removed grasp the door firmly and pull the latch lever, this will release the door. Repeat the process for double door units. Set the door(s) aside being careful not to damage the gaskets.
3. Remove the screws from the left side of the cabinet and set aside. Then remove the cabinet mounted part of the hinge and remount to the left side of the cabinet. Put the screws removed from the left side of the cabinet, into the remaining holes on the right side of the cabinet. Tighten all screws before proceeding.
4. Relocate the latch plate(s) from the left side to the right by removing the two mounting screws. Tighten all screws before proceeding.
5. On single door units rotate the door 180 degrees and align the door mounted hinge part with the cabinet mounted hinge part and tap the hinge pin into place so top of pin is flush with top of the cabinet mounted hinge part. Invert the door latch by removing black plastic screw covers and remove the screws holding the latch in place.
6. On double door units rotate the top-door 180 degrees and mount in the position of the lower door. Rotate what was the bottom-door 180

degrees and mount in the position of the top door. Align the door mounted hinge part with the cabinet mounted hinge part and tap the hinge pin into place so top of pin is flush with top of the cabinet mounted hinge part.

7. Relocate the label on the door(s). Be sure that there are no open screw holes on the front of the cabinet.

### B. SLIDE RACK ASSEMBLIES

All models of slide racks are removable for thorough cleaning.

On the inside of each cabinet are a series of rack hangers. These hangers have two slots for either an inboard or outboard rack position. To remove the slide rack, grasp and move upward until the pins are free of the hanger slots. To install the racks, locate the pins over the hangers and lower until locked into the slots.

**NOTE:** For an inboard rack position, use the slots farthest away from the wall of the cabinet. For an outboard rack position, use the slots closest to the wall of the cabinet.

#### C4SC/-T/-H — Model 4 (3" Slide Spacing fixed)

The Slide Rack consists of two (2) pair of slides and the C4SC-T and C4SC-H consist of (1) pair of slides. The pairs can be placed in the inboard or outboard position. The C4SC can have one pair in the inboard position and one pair in the outboard position. All pans are to be bottom loaded regardless of rack position. The following pans may be used:

Pan Size	Inboard Hanger Position (18" width)		
	C4SC	C4SC-T	C4SC-H
18"x26"x2 <sup>5</sup> / <sub>8</sub> "	17 pans	13 pans	8 pans
14"x18"x2 <sup>5</sup> / <sub>8</sub> "	17 pans	13 pans	8 pans

Max. pan size: 18"x27"x2<sup>5</sup>/<sub>8</sub>"  
Min. pan size: 17"

#### Outboard Hanger Position (20" width)

	C4SC	C4SC-T	C4SC-H
	17 pans	13 pans	8 pans
	14 pans	13 pans	8 pans
	34 pans	26 pans	16 pans
	28 pans	26 pans	16 pans

Max. pan size: 20"x27"x2<sup>5</sup>/<sub>8</sub>"  
Min. pan size: 19"

#### C8SN/-T/-H — Model 8 (1½" Spacing-fixed)

The Model 8 Slide Rack can only be installed in the inboard hanger position. All pans are to be lip loaded. The following pans may be used:

Model 8 Slide Rack			
C8SN	C8SN-T	C8SN-H	Pan Size
34 pans	28 pans	17 pans	18"x26"x1 <sup>3</sup> / <sub>8</sub> "

**CVSN-T/H — Model V (adjustable)**

The Model V Slide Rack can be installed in either an inboard or outboard position. Center spacing on slides can be either 3" or 4 1/2". Slides can be removed by lifting upward and sliding the rivet heads out of the keyhole slots. To install, select spacing, insert the rivet heads into the keyhole slots and push down until locked in the hole. All pans are to be bottom loaded regardless of slide or rack positioning.

With the racks in the inboard position (18" width), the following pans may be used:

3" Slide Spacing			Pan Size
CVSN	CVSN-T	CVSN-H	
16 pans	12 pans	8 pans	18" x26" x2 <sup>5</sup> / <sub>8</sub> "*
32 pans	26 pans	18 pans	12"x18"x2 <sup>5</sup> / <sub>8</sub> "**
32 pans	26 pans	18 pans	13"x18"x2 <sup>5</sup> / <sub>8</sub> "**
17 pans	13 pans	9 pans	14"x18"x2 <sup>5</sup> / <sub>8</sub> "**

Max. or combined pan size: 18"x27"x2<sup>5</sup>/<sub>8</sub>"  
 Min. pan width: 16"

4 1/2" Slide Spacing			Pan Size
CVSN	CVSN-T	CVSN-H	
11 pans	9 pans	6 pans	18"x26"x4 <sup>1</sup> / <sub>8</sub> "
22 pans	18 pans	12 pans	12"x18"x4 <sup>1</sup> / <sub>8</sub> "
22 pans	18 pans	12 pans	13"x18"x4 <sup>1</sup> / <sub>8</sub> "
22 pans	18 pans	16 pans	14"x18"x4 <sup>1</sup> / <sub>8</sub> "

Max. or combined pan size: 18"x27"x4<sup>1</sup>/<sub>8</sub>"  
 Min. pan width: 18"

With the racks in the outboard position (20" width), the following pans may be used:

3" Slide Spacing			Pan Size
CVSN	CVSN-T	CVSN-H	
17 pans	13 pans	9 pans	15"x20"x2 <sup>5</sup> / <sub>8</sub> "**
34 pans	26 pans	18 pans	10 <sup>7</sup> / <sub>8</sub> "x19 <sup>3</sup> / <sub>4</sub> "x2 <sup>5</sup> / <sub>8</sub> "**
34 pans	26 pans	18 pans	11 <sup>1</sup> / <sub>8</sub> "x20"x2 <sup>5</sup> / <sub>8</sub> "**
17 pans	13 pans	9 pans	20"x20"x2 <sup>5</sup> / <sub>8</sub> "**
16 pans	12 pans	8 pans	20"x22"x2 <sup>5</sup> / <sub>8</sub> "**
32 pans	24 pans	16 pans	12"x20"x2 <sup>5</sup> / <sub>8</sub> "**
17 pans	13 pans	9 pans	20"x24"x2 <sup>5</sup> / <sub>8</sub> "**

Max. or combined pan size: 20"x27"x2<sup>5</sup>/<sub>8</sub>"  
 Min. pan width: 16"

4 1/2" Slide Spacing			Pan Size
CVSN	CVSN-T	CVSN-H	
11 pans	9 pans	6 pans	15"x20"x4 <sup>1</sup> / <sub>8</sub> "
22 pans	18 pans	12 pans	10 <sup>7</sup> / <sub>8</sub> "x19 <sup>3</sup> / <sub>4</sub> "x4 <sup>1</sup> / <sub>8</sub> "
22 pans	18 pans	12 pans	11 <sup>1</sup> / <sub>8</sub> "x20"x4 <sup>1</sup> / <sub>8</sub> "
11 pans	9 pans	6 pans	20"x20"x4 <sup>1</sup> / <sub>8</sub> "
11 pans	9 pans	6 pans	20"x22"x4 <sup>1</sup> / <sub>8</sub> "
22 pans	18 pans	12 pans	12"x20"x4 <sup>1</sup> / <sub>8</sub> "
11 pans	9 pans	6 pans	20"x24"x4 <sup>1</sup> / <sub>8</sub> "

Max. or combined pan size: 20"x27"x4<sup>1</sup>/<sub>8</sub>"  
 Min. pan width: 18"

\*The top rack level is usable if the pan and product do not exceed 2" in height.

If this condition exists, an extra pan can be held.

**C1. HM2000 HOLDING MODULE**

**For Recommended Holding Temperatures, see HM2000 guidelines on page 6.**

When equipped with a holding module, your cabinet is designed to maintain the temperature of HOT prepared foods. The holding module is equipped with a thermostatically controlled heater, a blower for air circulation and a water pan. A POWER switch is provided with a red light to indicate when the unit is switched ON. Beside the POWER switch is the TEMPERATURE thermostat and its yellow indicator light.

A seven foot, three wire grounded lead cord is supplied fixed to the module. The cord cannot be separated from the module, so be careful when passing the cord through the cabinet back panel. Likewise, when installing the module into a cabinet, the cord must first be fed through the opening in the cabinet back panel.

1. With the POWER switch OFF, plug the cord into a standard grounded 20 amp, 125VAC grounded receptacle on an individual branch circuit.

**CAUTION: THE WATER PAN MUST BE IN PLACE DURING MODULE OPERATION.**

2. To introduce limited humidity, fill the 1 1/2-quart capacity water pan to 1/2" from the top with HOT clean tap water. During operation, check the water level every 3 hours and refill as necessary. The unit may be operated without water if humidity is not desired.
3. Push the POWER switch to the ON position by depressing the top of the switch. The red POWER lens in the switch will glow and the blower will begin circulating air. **Note: This is not a foot switch.** Using it as a foot switch can damage the switch and make the cabinet inoperable.
4. Turn the TEMPERATURE thermostat to a setting of 10. The holding unit is now in operation.
5. After allowing the cabinet to PREHEAT FOR APPROXIMATELY 45/60 MINUTES, reduce the thermostat setting to 6/8. In a room of average temperature (72°F), this should provide 150°- 170°F. Adjustments to the temperature may be made as necessary.

**THIS IS A HOT FOOD HOLDING CABINET AND IS NOT INTENDED TO RETHERMALIZE COLD FOOD. MAKE SURE FOOD AND CABINET ARE AT PROPER TEMPERATURES BEFORE PLACING FOOD IN THE CABINET.**

**NOTE:** The POWER (red) light will glow as soon as the POWER switch is switched ON and will continue to glow until switched OFF. The yellow indicator light will go on and off as the thermostat cycles. The blower will operate as long as the POWER switch is ON. If the yellow light is not illuminated, this indicates that the cabinet has achieved the preset TEMPERATURE level, NOT that the unit has been switched OFF.

It is not necessary at the end of the operating day to disrupt the TEMPERATURE setting in order to turn the unit OFF. By switching the POWER switch to OFF, the unit is no longer operating. By switching the POWER switch to ON when resuming operations, the cabinet setting will be at the previous set point.

## **C2. FL2000 HIGH HUMIDITY HOLDING MODULE**

**For Recommended Holding Temperatures, see FL2000 guidelines on page 5.**

When equipped with a high humidity module your cabinet is designed to maintain the temperature and moisture content of prepared foods. The module has controls for heat and humidity, a blower for air circulation and a removable water bottle. A POWER on/off switch is provided with a red light to indicate when the unit is ON. Beside the POWER switch are the TEMPERATURE and HUMIDITY control knobs and yellow lights to indicate when each element is on. A seven foot, three wire, grounded cord is supplied as part of the module.

1. With the POWER switch OFF, plug the cord into a standard 20 amp, 125VAC grounded receptacle on an individual branch circuit. **THE WATER BOTTLE SHOULD BE IN PLACE PRIOR TO AND DURING MODULE OPERATION.** Push the bottle in until you hear a click (indicating the valve half in the water bottle has engaged the valve half in the control panel).
2. To introduce humidity, fill the 2 gallon capacity water bottle to the fill spout with clean, cold tap water. **If you have hard tap water, use distilled water in the bottle.** During operation, check the water level every several hours and refill as necessary. The unit may be operated without water if humidity is not desired. If humidity is not required, turn the humidity knob to the OFF position. There is no need to remove any water from the bottle. During extended periods of operation without humidity, the bottle should be emptied of water. The next time humidity is required, clean and rinse the bottle and install it into the cabinet before refilling with clean, cold water. **If the cabinet is to be used for transporting food, empty the water bottle first.**
3. Push the POWER switch to the ON position by depressing the top of the switch. The red POWER lens in the switch will glow and the blower will begin circulating air. The thermometer display will show cabinet temperature. **Note: This is not a foot switch. Using it as a foot switch can damage the switch and make the cabinet inoperable.**
4. The thermometer display shows the current temperature in the cabinet. The temperature setting can be adjusted by turning the

temperature knob clockwise to increase and counter-clockwise to decrease temperature.

5. The humidity can be adjusted by turning the humidity knob clockwise to increase and counter-clockwise to decrease humidity. If you wish to hold food without using humidity, turn the Humidity control to MIN. This will prevent the cabinet from introducing additional humidity.
6. A buzzer alarm is located in the module to indicate low water level. Refilling the bottle will turn the buzzer off. If the bottle is not filled promptly, the humidity will begin dropping off in the cabinet. The bottle may be filled through the pour spout. The maximum fill level is to the fill opening. Turning the Humidity knob to MIN will stop the buzzer until water can be added. Then reset the humidity knob to the desired position.
7. Allow the cabinet APPROXIMATELY 45 to 60 MINUTES to reach the desired settings. **THIS IS A HOT FOOD HOLDING CABINET AND IS NOT INTENDED TO RETHERMALIZE COLD FOOD. MAKE SURE FOOD AND CABINET ARE AT PROPER TEMPERATURES BEFORE PLACING FOOD IN THE CABINET.**  
**NOTE:** The POWER switch red light will glow as soon as the POWER switch is turned ON. The yellow indicator light to the left of each control knob will go on and off as controls cycle the temperature and/or humidity elements. The blower will operate as long as the POWER switch is ON. If the yellow indicator light for the temperature control knob is not illuminated, this indicates that the cabinet has achieved the set TEMPERATURE. The light for the humidity control knob will continue to cycle on and off at a regular rate to maintain the desired humidity. It is not necessary at the end of the operating day to disrupt the TEMPERATURE or HUMIDITY settings in order to turn the unit OFF. By pushing the POWER switch to OFF, the unit is no longer operating. By pushing the POWER switch to ON when resuming operations, the cabinet settings will be at the previous settings.
8. The module can be removed for routine cleaning. **WHEN CLEANING, DO NOT SPRAY OR POUR WATER ON THE MODULE AND DO NOT IMMERSE THE MODULE IN WATER. WIPE WITH A DAMP CLOTH AND DRY WITH A TOWEL.** Turn the module off and remove the water bottle (this will allow the humidity generator to drain), racks and chimney. Remove the module from the cabinet by lifting the front up enough to clear the module slide detents, then pull the module from the cabinet, grasping it with both hands as it clears the cabinet. The cord cannot be separated from the module, so be careful when passing the cord through the cabinet back panel.

9. To install the module, reverse step 8. When installing the module into the cabinet, the cord must be fed through the opening in the cabinet back panel. Be careful that the seals on the side of the module go inside the module slides.

**To descale the humidity generator:**

To clean the humidity generator, use a commercially available descaling solution that is compatible with the stainless steel humidity generator and the aluminum cabinet interior. Pour the descaling solution into the water bottle, using the manufacturer's recommended dilution. With the bottle connected to the module, run the humidity generator at the maximum humidity

setting for the manufacturer's recommended time. Then, shut off the module, remove the water bottle and allow all the solution to drain out of the module quick disconnect valve. Empty the water bottle, and refill with clean water and a cup of baking soda and reinstall the bottle. Run the cabinet for another 30 minutes with the humidity generator at the maximum humidity setting. Again, shut off the module, remove the water bottle, allowing all the water to drain out of the front panel quick disconnect valve. Empty the water bottle and rinse; replace the bottle into the cabinet and refill with clean, cold water. The cabinet is now ready to use.

### III. FOOD HOLDING GUIDELINES

#### A. FL2000 Recommended Food Holding Guidelines

Food Product	Covered/Uncovered	Temperature Setting °F*	Moisture Setting
Baked Fish	Uncovered	175	Med/High
Baked Potatoes	Uncovered	180	Off
Biscuit	Uncovered	180	Medium
Broccoli	Covered	170-175	High
Chicken Nuggets	Uncovered	175	Off
Corn on the Cob	Covered	170-175	High
Croissants	Uncovered	175	Medium
Egg Patties	Covered	180	High
French Fries**	Uncovered	185	Off
Fried Chicken	Uncovered	180-185	Off
Fried Fish	Uncovered	180	Off
Hamburgers	Covered	180	Medium
Lasagna	Covered	185	High
Mashed Potatoes	Covered	175	High
Mixed Veggies	Covered	170-175	High
Pancakes	Covered	175	Medium
Pasta	Covered	180	High
Peas	Covered	170-175	High
Pizza	Uncovered	175-180	High
Roast Beef	Uncovered	170-180	Medium
Roast Pork	Uncovered	170-180	Medium
Scalloped Potatoes	Covered	175	High
Strip Steak	Uncovered	160-170	Medium
Turkey	Uncovered	170-180	Medium
Waffles	Covered	175	Medium
Whole Chicken	Uncovered	170-180	Medium

\*Temperatures are guidelines only, based on opening cabinet doors every 15 minutes.

\*\*Lightly salted for best quality.

Developed by Penn State University School of Hotel, Restaurant, and Recreation Management

### III. FOOD HOLDING GUIDELINES

#### A. HM2000/HM15LW Recommended Food Holding Guidelines

Food Product	Covered/Uncovered	Temperature Setting °F*
Baked Fish	Uncovered	175
Baked Potatoes	Uncovered	180
Biscuit	Uncovered	180
Broccoli	Covered	170-175
Chicken Nuggets	Uncovered	175
Corn on the Cob	Covered	170-175
Croissants	Uncovered	175
Egg Patties	Covered	180
French Fries**	Uncovered	185
Fried Chicken	Uncovered	180-185
Fried Fish	Uncovered	180
Hamburgers	Covered	180
Lasagna	Covered	185
Mashed Potatoes	Covered	175
Mixed Veggies	Covered	170-175
Pancakes	Covered	175
Pasta	Covered	180
Peas	Covered	170-175
Pizza	Uncovered	175-180
Roast Beef	Uncovered	170-180
Roast Pork	Uncovered	170-180
Scalloped Potatoes	Covered	175
Strip Steak	Uncovered	160-170
Turkey	Uncovered	170-180
Waffles	Covered	175
Whole Chicken	Uncovered	170-180

\*Temperatures are guidelines only, based on opening cabinet doors every 15 minutes.

\*\*Lightly salted for best quality.

Developed by Penn State University School of Hotel, Restaurant, and Recreation Management

## IV. CLEANING INSTRUCTIONS

### CAUTION

AT NO TIME SHOULD THE MODULE OR CABINET BE WASHED OR FLOODED WITH WATER OR LIQUID SOLUTION. NEVER STEAM CLEAN. SEVERE DAMAGE OR ELECTRICAL HAZARD COULD RESULT.

1. Turn off master switch.
2. Disconnect the unit from its power source.

### WARNING

ALLOW THE UNIT TO COOL BEFORE CLEANING, AS THE INTERIOR OF THE CABINET MAY BE HOT ENOUGH TO BURN. ALSO ALLOW THE WATER IN THE PAN (C199) OR BOTTLE (FL199) TO COOL BEFORE REMOVAL.

3. Open the door(s) and remove the slide racks and chimney.
4. If there is water in the pan or bottle, remove and empty.
5. Remove the module from the cabinet by lifting up the front enough to clear its detent, then pull the module away from the cabinet. The power cord slips through the clearance hole at the rear of the cabinet.
6. Do not use abrasive cleaners. For every cleaning method, best results are always obtained when the cleaner and technique are matched to the soil conditions involved. Contact your detergent representative to ensure the cleaning product being used is recommended for use on natural and epoxy coated aluminum. **FOLLOW THE MANUFACTURER'S DIRECTIONS ON CLEANERS. NEVER MIX CLEANERS.**
7. After cleaning, replace all components. Make sure the slide racks and chimney are seated in the hangers correctly.

#### A. SPECIFIC CLEANING INSTRUCTIONS

1. When cleaning, do not spray or pour water on the module and do not immerse the module in water. Wipe with a damp cloth and dry with a towel. Special attention should be paid to keeping the air-inlet area and the controls area free of dirt build-up.
2. Do not neglect to clean the under-chassis area, especially the area above each caster.
3. The cabinet or component(s) must be thoroughly rinsed to remove any residue that may stain the materials.
4. When choosing a cleanser, make sure the cleanser manufacturer recommends its use on natural and epoxy-coated aluminum.

#### B. GENERAL CLEANING INSTRUCTIONS

1. LIGHT SOIL  
If routine (daily) cleaning is practiced, a mild soap and warm water should be sufficient to keep the unit clean.
2. HEAVIER SOIL

If cleaning has been postponed, solvent or emulsion type cleaners that can be applied with bare hands will give excellent results. Such cleaners are available under various brand names and detergent suppliers can recommend materials appropriate for use on natural and epoxy-coated aluminum.

**NOTE:** For every cleaning method, best results are always obtained when the cleaner and technique are matched to the soil conditions involved. To ensure using the proper cleaner for natural and epoxy-coated aluminum, contact your detergent representative.

## V. MAINTENANCE

### A. CABINET MAINTENANCE — ALL MODELS

Your 199 series cabinet has been designed to require very little maintenance. With normal use, cleaning is the only form of maintenance that need be done on a regular basis. Keeping the casters free of dirt build-up will go a long way in prolonging their life.

If your cabinet is rolled over rough surfaces or transported over-the-road, the various threaded fasteners, i.e., screws and nuts, should be periodically inspected and tightened if necessary, particularly the transport latch, hinge and caster fasteners.

### B. MODULE MAINTENANCE

The module in the base of your cabinet has also been designed to require very little maintenance. With normal use, cleaning is the only form of maintenance that need be done on a regular basis. When cleaning, do not spray or pour water on the module and do not immerse the module in water. Wipe with a damp cloth and dry with a towel. Keeping vital areas such as the air-inlet area and the controls area free of dirt build-up will go a long way in prolonging the life of the electrical components. No maintenance is required on the electrical components.

### C. BLOWER MOTOR MAINTENANCE

The blower motor bearings should be lubricated annually.

1. To gain access to the motor, follow the instructions listed on page 10.
2. Remove the (2) rubber plugs, (1) located at each end of motor.
3. Apply 6 drops of a SAE 20 non-detergent oil to each bearing and re-install plugs.
4. Re-assemble module.

# VI. REPLACEMENT PARTS, PROCEDURES AND WIRING DIAGRAMS

## A. CABINET — ALL MODELS

Refer to the Cabinet Replacement Parts Diagram on next page to identify the replacement parts.

**C199 Series Cabinet Replacement Parts Diagram**  
(see page 9 for parts list)

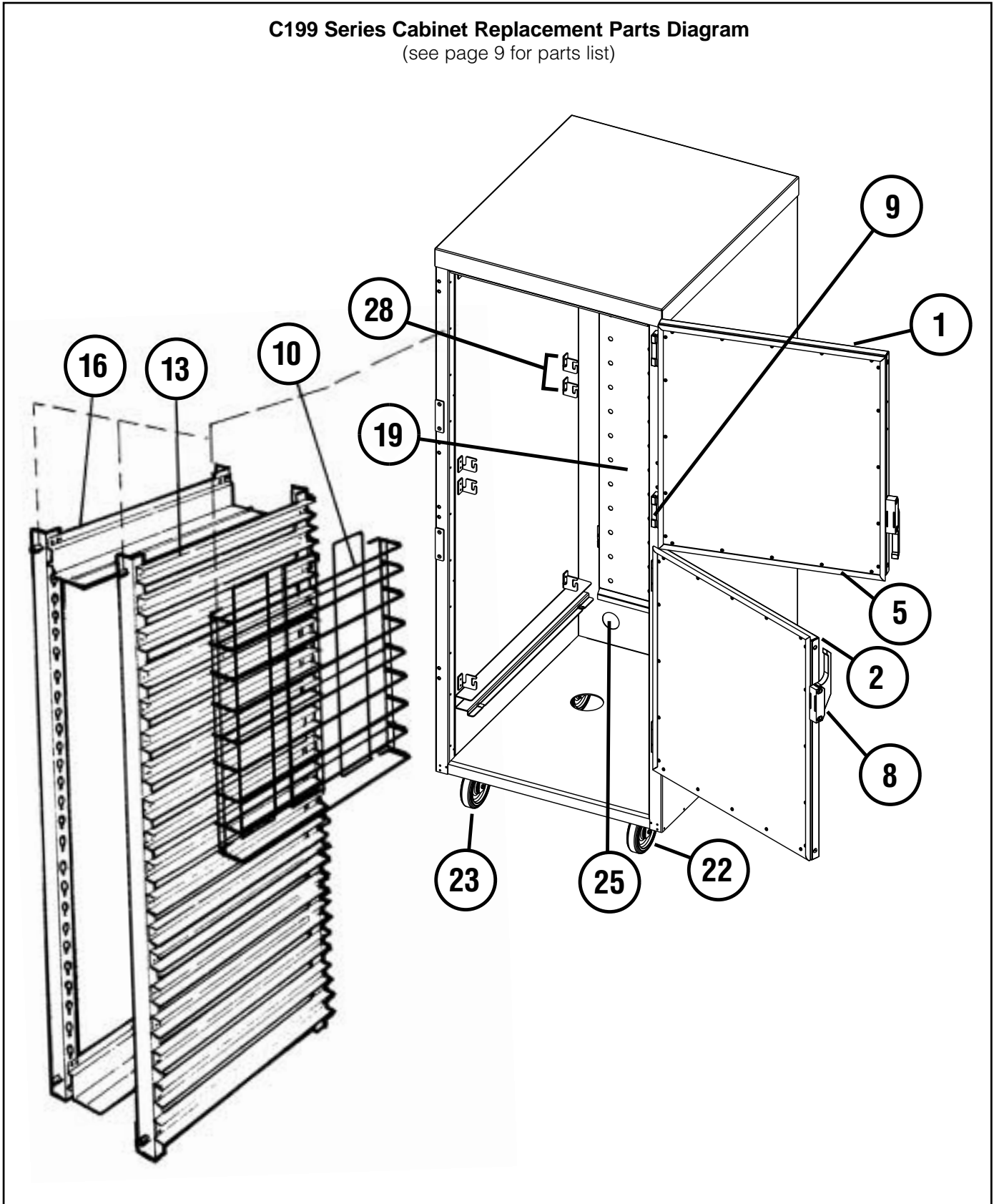

## CABINET REPLACEMENT PARTS LIST

( $\frac{1}{2}$  &  $\frac{3}{4}$  height cabinet parts not shown)

Item No.	Part No.	Description
1	<a href="#">RPC199P-1102T</a>	Top Door
2	<a href="#">RPC199P-1102B</a>	Bottom Door
3	RPC199HP-1102	Door ( $\frac{1}{2}$ height cabinet)
4	RPC199TP-1102	Door ( $\frac{3}{4}$ height cabinet)
5	<a href="#">RPC06-809</a>	Gasket (double door units)
6	<a href="#">RPC06-811</a>	Gasket ( $\frac{1}{2}$ height cabinet)
7	<a href="#">RPC06-810</a>	Gasket ( $\frac{3}{4}$ height cabinet)
8	<a href="#">RPC14-118</a>	Door Latch (strike plate included)
9	<a href="#">RPC14-119</a>	Door Hinge (complete assembly)
10	C4SC	C4SC Rack (full height cabinet) <i>(2 required for entire cabinet)</i>
11	<a href="#">C4SC-T</a>	<a href="#">C4SC-T</a> Rack ( $\frac{3}{4}$ height cabinet)
12	C4SC-H	C4SC-H Rack ( $\frac{1}{2}$ height cabinet)
13	<a href="#">C8SN</a>	<a href="#">C8SN</a> Rack (full height cabinet)
14	<a href="#">C8SN-T</a>	<a href="#">C8SN-T</a> Rack ( $\frac{3}{4}$ height cabinet)
15	<a href="#">C8SN-H</a>	<a href="#">C8SN-H</a> Rack ( $\frac{1}{2}$ height cabinet)
16	<a href="#">CVSN</a>	<a href="#">CVSN</a> Rack (full height cabinet)
17	<a href="#">CVSN-T</a>	<a href="#">CVSN-T</a> Rack ( $\frac{3}{4}$ height cabinet)
18	<a href="#">CVSN-H</a>	<a href="#">CVSN-H</a> Rack ( $\frac{1}{2}$ height cabinet)
19	<a href="#">RPC175-1108</a>	Chimney (full height cabinet)
20	RPC199H-1108	Chimney ( $\frac{1}{2}$ height cabinet)
21	RPC199T-1108	Chimney ( $\frac{3}{4}$ height cabinet)
22	<a href="#">B5DNB</a>	Caster With Brake
23	<a href="#">B5DN</a>	Caster Without Brake
24	<a href="#">RPC06-179A</a>	Drip Trough Pan — Plastic (not shown)
25	<a href="#">RPC13-106</a>	Snap Bushing
26	<a href="#">RPCAB-HBMPPR</a>	Handle Bumper (not shown)
27	<a href="#">RPC06-067</a>	Cabinet Bumper (not shown)
28	<a href="#">RPHANG-KIT</a>	Rack Hanger Kit (2 right-hand and 2 left-hand hangers)

## B. MODULE

Your module has been designed to be user-servicable, assuming a basic knowledge of the operation of electrical devices. This section has been written to guide the user step by step, and in layman's terms, through the dismantling and servicing of the module. Before attempting to service your module, read the appropriate Module Repair Procedures (found elsewhere in this section) thoroughly. If you do not understand the Repair Procedures or prefer not to service your module yourself, or if your warranty is still in effect, please contact our Customer Service Department for the factory authorized service agency nearest you.

The lead cord plug configuration designates whether your module uses a 15 or 20 amp service. Refer to the illustration below to identify the two different plugs.

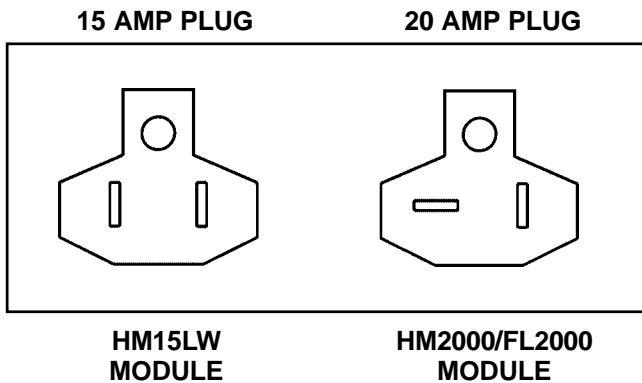

**CAUTION:** IT IS IMPORTANT THAT ALL SAFETY PRECAUTIONS PERTAINING TO THE SERVICING OF ELECTRICAL DEVICES BE OBSERVED AT ALL TIMES.

1. Dismantle your module for servicing per the following instructions.

**NOTE:** To replace the Thermostat and Humidity Knobs, or water pan/water bottle, it is not necessary to dismantle the module.

- a. Make sure the lead cord is **not** plugged into an outlet. Be certain that the module and any water in the water pan has cooled to a temperature safe for handling.
- b. Remove module by lifting the front enough to clear the detent, then pull the module from the cabinet, grasping it with both hands as it clears the cabinet. The cord should slip through the clearance hole in the back of the cabinet.

- c. Remove the water pan/water bottle and drain water.
  - d. Unfasten the electrical cover by removing the three screws along the front of the module and the two screws along each edge of the module. Retain this hardware for re-assembly.
  - e. Open the module by raising the component chassis from the electrical cover and placing the chassis top down on a dry, non-flammable work surface. IF NECESSARY TO RECONNECT THE OPENED MODULE TO A POWER SOURCE, PRACTICE EXTREME CAUTION SO AS NOT TO RECEIVE ELECTRICAL SHOCK FROM EXPOSED COMPONENTS.
2. Refer to the appropriate Module Replacement Parts Diagram to identify the internal components. Determine malfunctioning component(s) by electrical diagnostic procedures.
  3. After servicing, be sure to verify the routing of each wire with the wiring schematic before installing electrical cover and connecting module to power source. Be sure that the thermostat sensor tube does not contact any electrical connections.
  4. Assemble components using retained hardware, making sure that no wires are pinched between the cover and the component chassis.
  5. Install water pan/water bottle. Then, feed cord through clearance hole in cabinet and slide module into cabinet.

## Holding Module Replacement Parts Diagram

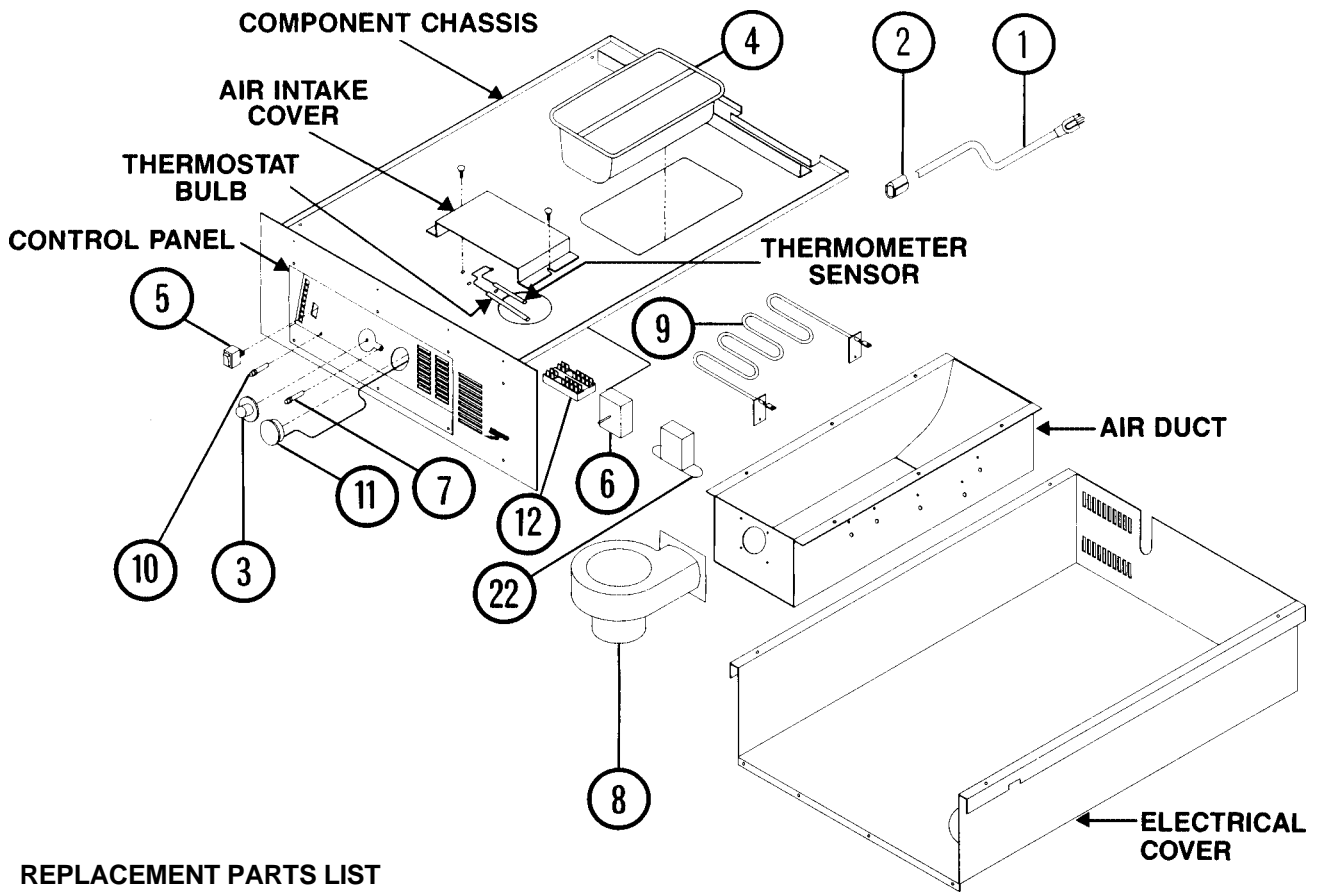

### REPLACEMENT PARTS LIST

Item No.	Part No.	Description
1	<a href="#">RPC13-017</a>	Power Cord — 15 AMP (HM15LW only)
2	<a href="#">RPC13-083</a>	Strain Relief — 15 AMP (HM15LW only)
3	<a href="#">RPC06-313</a>	Thermostat Knob
4	<a href="#">RPHM20-PAN</a>	Water Pan
5	<a href="#">RPC13-127</a>	Power Switch
6	<a href="#">RPC13-129</a>	Temperature Thermostat
7	<a href="#">RPC13-105</a>	Yellow Indicator Light
8	<a href="#">RPHM20-2103</a>	Circulating Blower
9	<a href="#">RPC13-114</a>	Heat Element — Units with 15 Amp Plug
9	<a href="#">RPC13-093</a>	Heat Element — Units with 20 Amp Plug
10	<a href="#">RPC13-064</a>	Red Indicator Light
11	<a href="#">RPC13-181</a>	Thermometer
12	<a href="#">RPC13-096</a>	Terminal Block — Control Panel
13	<a href="#">RPC13-012</a>	Ring Terminal
14	<a href="#">RPF02-042</a>	Push Nut — Indicator Lights
15	<a href="#">RPC11-191</a>	Blower Collar
16	<a href="#">RPC13-085</a>	Wire Nuts — 12 GA
17	<a href="#">RPC07-044</a>	Grommet — Thermometer Wire
18	<a href="#">RPC06-222</a>	Thermostat/Thermometer Bulb Clamp
19	<a href="#">RPC13-027</a>	1/4" Spade Terminals
20	<a href="#">RPC13-099</a>	Power Cord — 20 AMP
21	<a href="#">RPC13-098</a>	Strain Relief — 20 AMP
22	<a href="#">RPC13-183</a>	Thermometer Transformer

# VI. WIRING SCHEMATICS

## HOLDING WIRING DIAGRAM

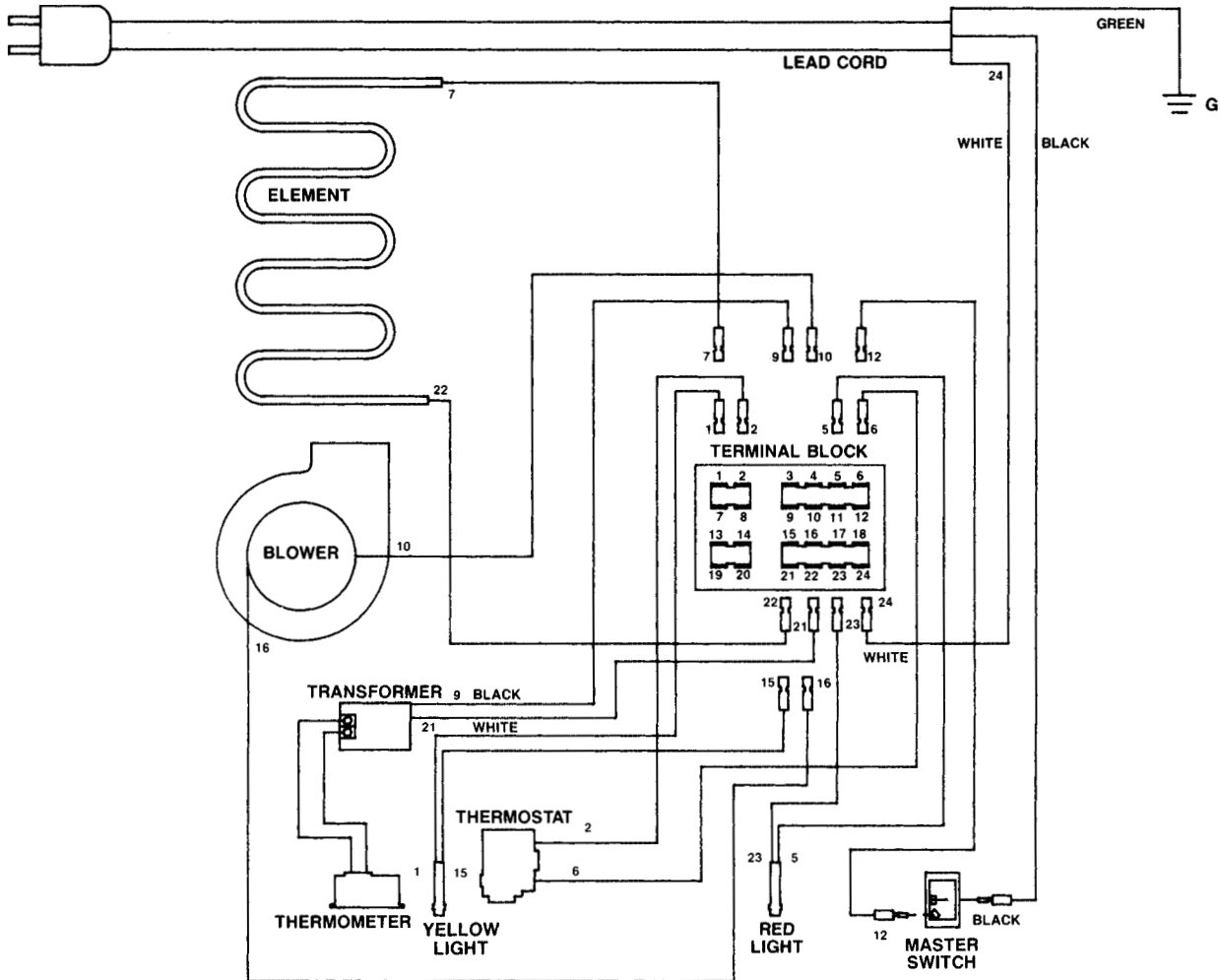

## FL2000 High Humidity Module Replacement Parts Diagram

### REPLACEMENT PARTS LIST

Item #	Part #	Description
1	RPC13-099	Power Cord — 20 AMP
2	RPC13-098	Strain Relief — 20 AMP
3	RPC06-746	Knob
4	RPC13-132	Power Switch
5	RPC13-181	Thermometer
6	RPC13-105	Yellow Indicator Light
7	RPC11-398	Heat Shield
8	RPC13-169	Buzzer Alarm
9	RPHM20-2103	Blower
10	RPC13-166	Heat Element
11	RPC09-117	Humidity Generator
12	RPC13-167	Band Heater
13	RPC13-168	Humidity Cut-out Switch
14	RPFL-3/8TUBE	Tubing
15	RPC13-096	Terminal Block
16	RPHM-WBA	Water Bottle
17	RPC15-024	Coupling
18	RPFL20-RMS	Rear Seal
19	RPFL20-SMS	Side Seal
20	RPC13-134	Hi-Temp Cut-out
21	RPC13-172	Percentage Timer
22	RPC13-129A	Thermostat
23	RPC13-173	Relay
24	RPC13-174	Transformer
25	RPC13-171	Potentiometer
26	RPC13-012	Ring Terminal
27	RPF02-042	Push Nut — Indicator Lights
28	RPC11-191	Blower Collar
29	RPC13-085	Wire Nuts — 12 GA
30	RPC07-044	Grommet — Thermometer Wire
31	RPC06-222	Thermostat/Thermometer Bulb Clamp
32	RPC13-027	1/4" Spade Terminals
33	RPC13-183	Thermometer Transformer

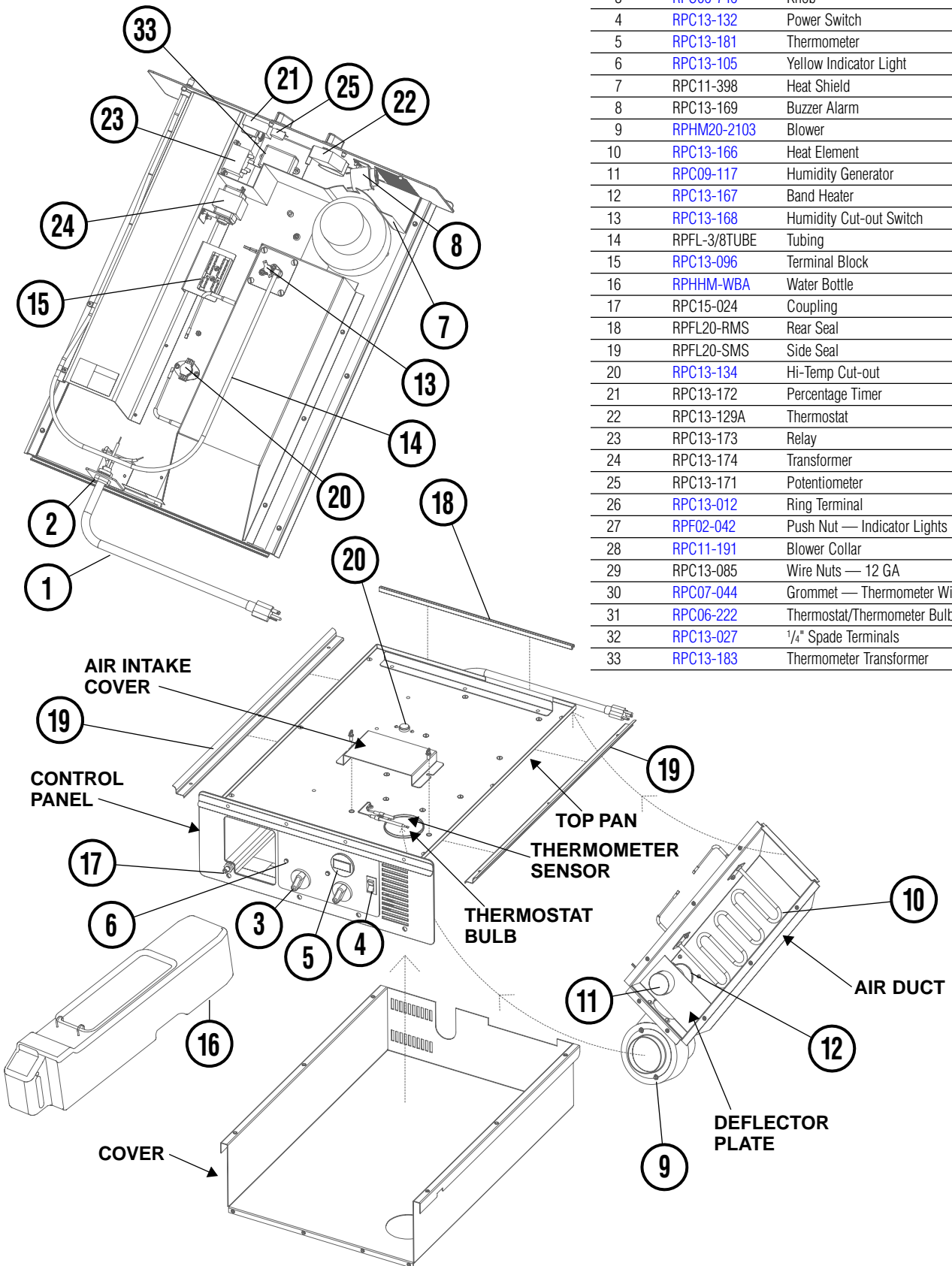



Thank you for purchasing a Metro Mobile Heated Cabinet. We are certain you will be more than satisfied with its quality and performance. Please fill in the warranty information space below so we may register your warranty. Also, so that we may learn more about our customers and hopefully be of continued service in the future, please take a moment to fill in the customer information space below.

*Thank You*

CUT ALONG DOTTED LINE

**CUSTOMER INFORMATION**

**1. Which one of the following best describes your establishment?**

- a.  Full Service Restaurant
- b.  Fast Food Restaurant
- c.  Hotel/Motel
- d.  Hospital/Nursing Home
- e.  College/University
- f.  School
- g.  Employee Feeding
- h.  Other \_\_\_\_\_

**WARRANTY INFORMATION:**

Cabinet Model No. \_\_\_\_\_  
 Module Serial No. \_\_\_\_\_  
 Slide Rack Model No. \_\_\_\_\_  
 Date Purchased \_\_\_\_\_  
 Customer Name \_\_\_\_\_  
 Address \_\_\_\_\_  
 \_\_\_\_\_  
 \_\_\_\_\_  
 Phone No. \_\_\_\_\_

***For warranty coverage, this card must be returned to Metro.***

FOLD HERE — DO NOT DETACH

CUT ALONG DOTTED LINE

**2. Please indicate the two product benefits that were of major interest to you.**

- a.  Accessibility to controls without opening door.
- b.  All components within cabinet removable for cleaning.
- c.  Better control of conditions in cabinet.
- d.  Uniform environment within cabinet due to forced air circulation, chimney design and gasketed doors.
- e.  Reversible doors.
- f.  Aesthetic quality (styling).
- g.  Other (in addition to above two) \_\_\_\_\_  
 \_\_\_\_\_

**3. Main factor that led to your decision to purchase this product?**

- a.  Product operating and functional features
- b.  Overall quality
- c.  Price
- d.  Availability
- e.  Other \_\_\_\_\_

**4. Three sources that led to the purchase of this product — in the order of their impact (1 - being most impact; 3 - being least impact).**

- a.  Trade Journal Ad
- b.  Trade Show
- c.  Sales Call
- d.  Direct Mail
- e.  Previous Purchase
- f.  Other \_\_\_\_\_



WILKES-BARRE PA 18705-9968

P O BOX A

ATTN: CUSTOMER SERVICE

INTERMETRO INDUSTRIES CORPORATION

POSTAGE WILL BE PAID BY

**BUSINESS REPLY MAIL**  
FIRST-CLASS PERMIT NO. 121 WILKES-BARRE, PA

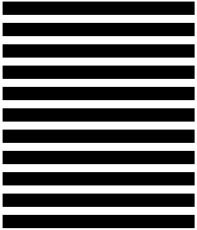

NO POSTAGE  
NECESSARY  
IF MAILED  
IN THE  
UNITED STATES

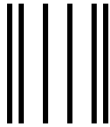

FOLD HERE — DO NOT DETACH

STAPLE HERE

STAPLE HERE

STAPLE HERE

# Warranty

## WARRANTY, EXCLUSION OF WARRANTIES AND LIMITATION OF LIABILITY.

InterMetro Industries Corporation (hereinafter referred to as "Seller") warrants to the original purchaser that all products in its catalog, or custom products, delivered hereunder will be free from defects in workmanship and material. THE FOREGOING WARRANTY IS EXCLUSIVE AND IN LIEU OF ALL OTHER WARRANTIES, EXPRESS, IMPLIED OR STATUTORY, INCLUDING ANY WARRANTY OF MERCHANTABILITY OR FITNESS FOR A PARTICULAR PURPOSE. This Warranty shall be for a period of one (1) year from the date of shipment from Seller's warehouse or factory. If any product delivered hereunder does not meet the Warranty specified above, providing the product has not been altered in any way by anyone other than Seller's factory-authorized representative, and assuming normal and proper use and maintenance, Seller will, at its option, repair or replace any part or material it determines, upon inspection, to be defective; provided however, that a charge for labor will be made except during a period of one (1) year from the date of original shipment from Seller's warehouse or factory. No product, or part thereof, is to be returned to Seller without prior written approval from Seller's factory. All exchanges and replacement shipments will be F.O.B. Seller's factory. Warranties for equipment or articles not manufactured by the Seller are solely the warranties of the manufacturers thereof and they are hereby assigned to the purchaser without recourse to the Seller.

SELLER'S LIABILITY FOR ANY CLAIM OF ANY KIND, WHETHER BASED ON CONTRACT, NEGLIGENCE OR STRICT LIABILITY IN TORT, AND BY WHOMEVER MADE, FOR ANY DIRECT, INDIRECT, INCIDENTAL OR CONSEQUENTIAL LOSS, DAMAGE OR INJURY, RESULTING TO THE PURCHASER OR ANY THIRD PARTIES, arising out of, connected with or resulting from this Agreement, or from the performance or breach thereof, or from the manufacture, sale, delivery, resale, installation, inspection, repair or use of any product covered by or furnished under this Agreement, WHETHER OR NOT CAUSED BY SELLER'S NEGLIGENCE, SHALL IN ALL EVENTS BE EXCLUSIVELY LIMITED TO THE COST OF CORRECTING DEFECTIVE, DAMAGED OR NON-CONFORMING PARTS OR MATERIAL AS HEREIN PROVIDED, and upon the expiration of one (1) year, all such liability shall terminate.

SELLER DOES NOT AUTHORIZE any person to assume for it any obligations or liabilities greater than or different than those set forth in this Warranty. The terms under which any of Seller's products may be resold must be limited in accordance with this Warranty.

THIS AGREEMENT, and all the rights and obligations arising hereunder, shall be construed in accordance with, and be governed by, the law of the Commonwealth of Pennsylvania, U.S.A.

TO INSURE WARRANTY implementation, return the completed registration card within 15 days of cabinets' receipt to: InterMetro Industries Corp., Wilkes-Barre, PA 18705



**InterMetro Industries Corporation**  
Wilkes-Barre, PA 18705



**InterMetro Industries Corporation**

North Washington Street, Wilkes-Barre, PA 18705

For Product Information Call: 1-800-433-2232

Visit Our Web Site: [www.metro.com](http://www.metro.com)

L01-386

Rev. A 03/03

Information and specifications are subject to change without notice. Please confirm at time of order.