



TECHNICAL MANUAL

Installation, Operation and Maintenance Instructions

50-20N2-NSU

Door Type Dishwasher

Insinger Machine Company
6245 State Road
Philadelphia, PA 19135-2996

800-344-4802
Fax: 215-624-6966
www.insingermachine.com

CERTIFICATION SHEET

TECHNICAL MANUAL VALIDATION CERTIFICATE

TECHNICAL MANUAL TITLE: Insinger Machine Co. Dishwashing Machine Model 50-20N2-NSU; Installation, Operations, Maintenance and Troubleshooting Manual

MANUFACTURER: Insinger Machine Co.
MODEL NUMBER: 50-20N2-NSU

TECHNICAL MANUAL IDENTIFICATION NUMBER (TMIN):	DATE:
T6161-FB-FSE-010	1 May 2011

CONTRACT/TMCR NO.:
N00024-03-C-2311 AND N00024-09-C-2303

I. VALIDATION(S) PERFORMED: TYPE 3

TYPE 3 = Desktop review/Analysis only
TYPE 2 = Walk-through simulation method
TYPE 1 = Physical performance

NOTE: Except as stated in II, the technical manual identified above has been satisfactorily validated in accordance with all requirements of the applicable TMCR and the approved Validation Plan. This technical manual is hereby certified to be accurate and complete, and the information, instructions, text and illustrations conform in all respects to the applicable general and detailed specifications. This technical manual is applicable to the Littoral Combat Ship (LCS) class ship.

II. EXCEPTIONS

EXCEPTIONS (Brief Description and Reference)	AUTHORIZED BY (Government Representative Name/Code)
---	--

SIGNATURE OF CONTRACTOR'S PUBLICATIONS QUALITY ASSURANCE OFFICER	DATE
Mark A. Landry 	1 May 2011

NAVSEA/SPAWAR 4160/3(12-93)

REVISION RECORD

Revision Record

Revision No.	Technical Freeze Date	Date	Title or Brief Description
00		30 March 1995	Original Issue
01	30 November 2009	1 May 2011	Updated Part Numbers

FOREWORD

This technical manual provides a source of technical information for shipboard and shore side operation, maintenance, troubleshooting and repair activities.

The scope of this technical manual covers the equipment, at the equipment level, and combines an overall description along with basic operating procedures, maintenance, troubleshooting and parts lists.

Chapter 1 – General Information and Safety Precautions.

Chapter 2 – Operation.

Chapter 3 – Functional Description.

Chapter 4 – Scheduled Maintenance.

Chapter 5 – Troubleshooting.

Chapter 6 – Corrective Maintenance.

Chapter 7 – Parts List.

Chapter 8 – Installation.

Chapter 9 – Electrical Information.

Appendix A – Water Level Indicator Retrofit Kit #K100-015.

CONFIGURATION STATUS. This manual covers the Littoral Combat Ship (LCS) with the modifications listed. Included in this list is a brief description of the modification and the technical manual revision number that incorporated the modification. The term baseline, as used in this manual, defines a particular computer program configuration. Due to ship schedules and availability, not all ships have the same complement of hardware and software approved for a particular baseline. When necessary, field modification reference data are used to denote variations in this manual. Modification data may include, but is not limited to Baseline changes, Engineering Change Proposals (ECPs), Marinette Marine Change Notices/Lockheed Martin Change Notices (MMCNs/LMCNs), Ordnance Alterations (ORDALTs), and Ship Alterations (SHIPALTs). A double zero in the revision number column indicates that the modification was incorporated in the original issue. A dash (-) in the revision number column indicates that the modification has no effect on the technical content of the manual.

Modification Record

No.	Description	Revision No.
None		

TECHNICAL MANUAL DEFICIENCY/EVALUATION REPORT (TMDER) STATUS. Ships, training activities, supply points, and shipyards are requested to arrange for the maximum practical use and evaluation of NAVSEA technical manuals. All errors, omissions, discrepancies, and suggestions for improvement to NAVSEA technical manuals shall be reported to:

COMMANDER
CODE 310 TMDER BLDG 1389
NAVSURFWARCENDIV NSDSA
4363 MISSILE WAY
PORT HUENEME, CA 93043-4307

If form NAVSEA 4160/1 is not available, users can transmit deficiency submittals via the Naval Systems Data Support Activity (NSDSA) TMDER Web page located at: <https://nsdsa2.phdnswc.navy.mil/tmder/tmder-generate.asp>.

All feedback comments shall be thoroughly investigated and originators will be advised of action resulting therefrom.

NOTE

DO NOT e-mail TMDERs containing classified information or unclassified sensitive technical information over a public network (Internet). Even fragmentary unclassified information of a TMDER can become sensitive if description or attachments include comments about impact or can relate to vulnerabilities or capabilities.

If this ETM is running on a system with a security classification higher than the ETM, the TMDERs this system creates shall be considered classified at the highest level of the system. Follow all security guidance for handling and transmitting classified data at this level.

Copy classified or sensitive files to CD-ROM, rather than using public networks. Double wrap, label, and mail in accordance with current security regulations.

This manual incorporates user comments from the listed TMDER. The origination ship/activity follows the TMDER number.

TMDER Record

TMDER No.	Originator	Revision No.
None		

GLOSSARY

This glossary contains the acronyms and abbreviations used in this binder. The acronyms and abbreviations are listed in alphabetical order.

°F Degrees Fahrenheit

C

CNET Chief of Naval Education and Training

E

ECP Engineering Change Proposal

F

FIPS Female Iron Pipe Size

H

H Height

Hp Horse Power

Hz Hertz

I

IN Inch

IN. DIA. Inside Diameter

IPS Iron Pipe Size

L

L	Length
Lbs	Pounds
LCS	Littoral Combat Ship
LMCN	Lockheed Martin Change Notice

M

MM	Millimeter
MMCN	Marinette Marine Change Notice

N

NAVSEA	Naval Sea Systems Command
NPT	National Pipe Thread
NSDSA	Naval Systems Data Support Activity

O

O.D.	Outside Diameter
ORDALT	Ordnance Alteration

P

PSI Pounds Per Square Inch

PSIG Pounds Per Square Inch Gauge

R

RPM Revolutions Per Minute

S

SHIPALT Ship Alteration

SSP Strategic Systems Programs

SWS Surface Warfare Specialist

T

TFR Trouble Failure Report

TMDER Technical Manual Deficiency/Evaluation Report

TTO Training Time Out

V

V Volts

W

W Width

TABLE OF CONTENTS

CHAPTER/PARAGRAPH	PAGE
SAFETY SUMMARY	iv
INSINGER MACHINE COMPANY LIMITED WARRANTY	vi
WARRANTY REGISTRATION	viii
1. GENERAL INFORMATION AND SAFETY PRECAUTIONS	1-1
1.1 INTRODUCTION	1-1
1.2 DESCRIPTION	1-1
1.2.1 General	1-1
1.2.2 System Components	1-1
1.2.3 System Specifications	1-1
2. OPERATION	2-1
2.1 INTRODUCTION	2-1
2.2 CONTROLS AND INDICATORS	2-1
2.2.1 Steam Booster/Heat Exchanger	2-1
2.2.2 50-20N2(C)-NSU Dishwasher Control Panel	2-1
2.2.3 Temperature and Pressure Gauges	2-2
2.2.4 Tank Water Level	2-2
2.2.5 Detergent Holder, Dispenser, and Rinse Injector	2-2
2.3 OPERATING PROCEDURES	2-2
2.3.1 50-20N2(C)-NSU Dishwasher Preparation	2-2
2.3.2 Tank Fill	2-3
2.3.3 Load 50-20N2(C)-NSU Dishwasher	2-4
2.3.4 Unload 50-20N2(C)-NSU Dishwasher	2-4
2.3.5 Shut Down 50-20N2(C)-NSU Dishwasher	2-4
2.3.6 Drain and Clean 50-20N2(C)-NSU Dishwasher	2-5
3. FUNCTIONAL DESCRIPTION	3-1
3.1 INTRODUCTION	3-1
3.2 DESCRIPTION OF EQUIPMENT OPERATION	3-1
4. SCHEDULED MAINTENANCE	4-1
4.1 INTRODUCTION	4-1
4.2 DESCRIPTION OF SCHEDULED MAINTENANCE TASKS	4-1
4.2.1 After Each Operation	4-1
4.2.2 Weekly	4-1
4.2.3 Semi-Annually	4-1
5. TROUBLESHOOTING	5-1
5.1 INTRODUCTION	5-1
5.2 TROUBLESHOOTING PROCEDURES	5-1
6. CORRECTIVE MAINTENANCE	6-1
6.1 INTRODUCTION	6-1
6.2 REPAIR AND REPLACE PROCEDURES	6-1

TABLE OF CONTENTS (continued)

CHAPTER/PARAGRAPH	PAGE
6.2.1 Disassembly of Solenoid Valve	6-1
6.2.2 Disassembly of Recirculating Pump	6-1
6.3 DIAGNOSIS, REPAIR AND REPLACE PROCEDURES	6-2
6.3.1 Thermometers	6-2
6.3.2 Steam Temperature Regulator and Traps	6-2
6.3.3 Solenoid Valves	6-3
6.3.4 Electronic Temperature Controller	6-4
7. PARTS LIST	7-1
7.1 REPLACEMENT PARTS LIST	7-1
Dishwasher, Model 50-20N2-NSU (Standard), Dwg. SK-2839 (2 sheets)	7-2
Dishwasher, Model 50-20N2-NSU NM, Dwg. SK-2987	7-4
Dishwasher, Model 50-20N2C-NSU (Corner), Dwg. SK-2837 (2 pages)	7-5
1 HP Pump, Dwg. SK-2462	7-7
1 HP Bronze Pump, Dwg. SK-2986	7-8
Drain Assembly, Dwg. SK-3028	7-9
Steam Coil, Diode JCT, and Liquid Level Float Locations, Dwg. 1089-82	7-10
Electric Htr., Diode & Liquid Level Float Locations, Dwg. 1089-80	7-11
Liquid Level Float Typical Installation, Dwg. 1089-189	7-12
Steam Booster Assembly w/ Power Unloader, Dwg. 1394-2	7-13
Electric Booster Assembly, Dwg. 1089-87	7-14
7.2 RECOMMENDED PROVISIONING	7-15
7.3 STANDARD PARTS LIST	7-16
8. INSTALLATION	8-1
8.1 GENERAL	8-1
8.2 PLACEMENT	8-1
8.2.4 Final Installation	8-1
8.2.5 Electrical Connections	8-2
8.2.6 Mechanical Operations	8-2
8.3 INSTALLATION VERIFICATION	8-2
9. ELECTRICAL INFORMATION	9-1
9.1 GENERAL	9-1
9.2 Electrical Immersion Heaters	9-1
9.2.1 General Information	9-1
9.2.2 Instructions for Installation and Maintenance	9-2
9.3 Installation Instructions for Hatco Electric Booster Water Heaters	9-2
9.3.1 General Instructions	9-2
9.3.2 Installation	9-2
10. APPENDIX A	10-1

LIST OF ILLUSTRATIONS

Figure No.	Title	Page No.
1	Installation Drawing - Standard Model (shown with electric booster)	1-4
2	Installation Drawing - Corner Model (shown with electric booster)	1-5
3	Dishwasher, Model 50-20N2-NSU (Standard)	7-2
4	Dishwasher, Model 50-20N2C-NSU (Corner)	7-5
5	1 HP Pump	7-7
5A	1 HP Bronze Pump	7-8
6	Drain Assembly	7-9
7	Steam Coil, Diode JCT, and Liquid Level Float Locations	7-10
8	Electric Htr., Diode & Liquid Level Float Locations	7-11
9	Liquid Level Float Typical Installation	7-12
10	Steam Booster Assembly	7-13
11	Electric Booster Assembly	7-14
12	Wiring Diagram, Steam Booster, Dwg. WD00R010	9-3
12A	Wiring Diagram, Electric Booster, Dwg. WD00R020	9-4
13	Control Panel, Dwg. SK-3490 (2 pages)	9-5
14	Electric Booster Wiring	9-7

LIST OF TABLES

Table No.	Title	Page No.
1	Specification Summary and Required Support	1-2
2	Equipment Supplied	1-3
3	Troubleshooting and Service	5-2

SAFETY SUMMARY

GENERAL PRECAUTIONS

The following general safety notices supplement the specific warnings and cautions appearing in the manual:

All service except for cleaning and refilling water and detergent should be performed by qualified maintenance personnel.

Electrical equipment must be turned off before servicing.

WARNINGS AND CAUTIONS

There are warnings and cautions appearing throughout the text of the manual to alert operating and maintenance personnel to potentially hazardous situations. The following is a summary of all warnings and cautions and the page number on which they are found:

<div style="border: 1px solid black; padding: 2px; display: inline-block;">WARNING</div>	PAGE
Inspection doors must be closed during operation.	2-4
Do not open detergent dispenser while machine is in operation. If more washing compound is needed, shut machine down before adding additional detergent.	2-4
Washware exiting the machine is very hot. Care must be taken during unloading.	2-4
Before opening the wash and rinse tank drains on 50-20N2(C)-NSU dishwasher make sure the tank temperatures have cooled down to below 120 °F and that the entire system has been shut down.	2-5
Electrical equipment must be turned off before servicing.	2-5 4-1 6-1 9-1
 CAUTION 	
Only washing detergent and amounts specified in BuShips Publication NavShips 250-522, titled: "Operation and Maintenance of Dishwashing Machines," may be used in this Dishwasher.	2-3
Do not hose down machine.	4-1

CAUTION (continued)

- The pump must never be run for a period greater than 30 seconds without water in the tank. 8-2
- Never bend the booster heating elements (Figure 12). 9-1
If bending is necessary, check with the factory. 9-2
- Do not supply current to the booster heater (Figure 12) until the tank has been filled and all air has been vented through the dishwasher rinse nozzles. The heating elements will burn out in seconds if they are not covered with water. 9-1
9-2
- Care must be taken to ensure complete immersion of the heated length of the heater at all times. 9-2
The heated surface should never be in contact with any sludge.

INSINGER MACHINE COMPANY
LIMITED WARRANTY

Insinger Machine Company, Inc. (Insinger) hereby warrants to the original retail purchaser of this Insinger Machine Company, Inc. product, that if it is assembled, installed, and operated in accordance with the printed instructions accompanying it, that said Insinger product shall be free of defects in material and workmanship, for a period of one (1) year (12 months) after the date of installation or fifteen (15) months from the date of shipment from Insinger, whichever occurs first, provided the warranty registration card is returned to Insinger within 15 days after installation. If the Warranty Registration Card is not returned to Insinger within this period, the warranty will expire after one year from the date of shipment from the factory. Insinger will not assume any responsibility of extra costs for installation in any areas where there are jurisdictional problems with local trades or unions.

Insinger may require reasonable proof of your date of purchase. Therefore, you should retain your copy of the invoice or shipping document.

This limited warranty shall be limited to the repair of parts which prove defective under normal use and service within the warranty period set forth above, and which on examination shall indicate, to Insinger's satisfaction, that the parts are defective. Insinger will repair the defective part of parts. All warranty work must be done during normal working hours, by either an Insinger Appointed Service Agency or an agency receiving prior authorization from Insinger. Defective parts become the property of Insinger. Parts replaced within the warranty period carry a warranty only until the end of the original limited warranty period. Replacement parts not supplied by Insinger will relieve Insinger of all future liability and responsibility.

This limited warranty does not cover: lighting of gas pilots or burners, cleaning of gas lines, replacement of fuses or resetting of overload breakers, adjustment of thermostats, adjustment of clutches, opening or closing of utility supply valves or switching of electrical supply, cleaning of valves, strainers, screens, nozzles, or spray pipes, performance of regular maintenance and cleaning as outlined in the TECH MANUAL, damages resulting from water conditions, accidents, alterations, improper use, abuse, misapplication, tampering, improper installation or failure to follow maintenance and operation procedures, fire, flood, acts of God or improper maintenance or service, or for improper operation or failure to follow normal operating instructions (as set out in the TECH MANUAL) or failure as a result of the aforesaid.

INSINGER LIMITED WARRANTY

Page 2

Examples of the aforementioned, but without limitations, are: damage to exterior or interior finish as a result of the above, use with utility service other than that designated on the rating plate, improper connection to utility service, inadequate or excessive water pressure, corrosion from chemicals dispensed in excess of recommended concentrations, failure of electrical components due to connection of chemical dispensing equipment installed by others, leaks or damage resulting from such leaks as made by installer including those at machine table connections or by connections of chemical dispensing equipment installed by others, failure to comply with local building codes, damage caused by labor dispute.

Insinger is not responsible nor liable for any conditions of erosion or corrosion caused by corrosive detergents, acids, lye or other chemicals used in the washing and/or cleaning process.

THIS WARRANTY IS THE ONLY WARRANTY APPLICABLE TO INSINGER PRODUCTS AND IS EXPRESSLY IN LIEU OF ALL OTHER EXPRESS OR IMPLIED WARRANTIES, INCLUDING ANY IMPLIED WARRANTY OF MERCHANTABILITY OR FITNESS FOR A PARTICULAR PURPOSE, AND ANY OTHER OBLIGATION ON THE PART OF INSINGER. THE REMEDY CONTAINED IN THIS WARRANTY IS THE SOLE REMEDY FOR ANY DEFECT FOUND TO EXIST IN AN INSINGER PRODUCT AND ALL OTHER DAMAGES ARE EXCLUDED, INCLUDING ANY LIABILITY FOR INCIDENTAL OR CONSEQUENTIAL DAMAGE.

Insinger does not authorize any person or company to assume for it any other obligation or liability in connection with this warranty or for any sale, installation, use, removal, return or replacement of its equipment; and no such representations are binding on Insinger.

THIS LIMITED WARRANTY SUPERSEDES ALL OTHER EXPRESS WARRANTIES, IMPLIED WARRANTIES OF MERCHANTABILITY AND FITNESS OR LIMITED WARRANTIES AS OF JANUARY 1, 1993.



100 Years of Service

Thank you for Purchasing this quality Insinger product.

On the space provided please record the Model and Serial Number of this unit:

Model: _____

Serial Number: _____

When referring to this equipment please have these numbers available.

Each piece of equipment at Insinger is carefully tested before shipment for proper operation. If the need for service should arise please contact your local Authorized Insinger Service Company. If you do not know the name of your Authorized Service Company please contact our Technical Services Department toll-free, 800.344.4802.

For proper activation of the *Insinger Limited Warranty* the **Warranty Registration Card** provided with your unit must be returned within 15 days of the installation date.

Please read the *Insinger Limited Warranty* and all installation and operation instructions carefully before attempting to install or operate your new Insinger product.

To register your machine for warranty by phone, or for answers to questions concerning installation, operation, or service contact our Technical Services Department toll-free, 800.344.4802.

Thank you.

Insinger Machine Company

CHAPTER 1

GENERAL INFORMATION AND SAFETY PRECAUTIONS

NOTE

Refer to SAFETY SUMMARY for the safety warnings and cautions used in this manual.

1.1 INTRODUCTION

1.1.1 This manual pertains to the Insinger 50-20N2-NSU and 50-20N2C-NSU dishwashers. The "C" designates a corner model. Where there is no differentiation within the text of this manual between the standard and the corner models, the number 50-20N2(C)-NSU shall be used.

1.1.2 The manual contains information covering installation, operation, maintenance, repair and troubleshooting procedures. A parts list is also included.

1.2 DESCRIPTION

1.2.1 GENERAL. Insinger 50-20N2(C)-NSU dishwashers are expressly designed for onboard ship use. They can be used periodically or continuously, as need dictates.

1.2.2 SYSTEM COMPONENTS. The Insinger 50-20N2(C)-NSU dishwashers consist of two major components: a dishwashing machine and a booster/heat exchanger. In addition, the 50-20N2(C)-NSU dishwashers include both a detergent dispenser and a rinse injector.

1.2.3 SYSTEM SPECIFICATIONS. The physical and electrical specifications of the 50-20N2(C)-NSU dishwasher system are summarized in Table 1, along with required utilities, their hook-ups, and consumables. The equipment supplied is described in Table 2.

TABLE 1

INSINGER 50-20N2 (C) -NSU DISHWASHER

SPECIFICATION SUMMARY AND REQUIRED SUPPORT

CHARACTERISTIC	DESCRIPTION
Overall Dimension	
Width	24"
Height	76" (with doors open)
Depth	30 1/8"
Operation	45 seconds/cycle
Initial Fill Time	2 minutes
Tank Capacity	5.6 gallons
Electrical Requirement	440 V, 3 phase, 60 Hz
Steam Requirements (Steam Heated Machines Only)	
Pressure	10 - 35 PSIG
Volume - Booster	65 lbs/hr
- Tank	42 lbs/hr
- Total	107 lbs/hr
Hot Water Requirements	
Supply Temperature (to the booster)	140 °F
Volume	88 gallons/hr final rinse (1.2 gallons/cycle)
Drainage Requirements	1 1/2" NPT 2 condensate returns - 3/8" NPT
Washing Requirements	detergent compound specified by BuShips publication NavShips 250-522.

TABLE 2

INSINGER 50-20N2 (C) -NSU DISHWASHER

EQUIPMENT SUPPLIED

QTY.	NAME	PART NUMBER	OVERALL DIMENSIONS UNCRATED	WEIGHT UNCRATED
1	50-20N2-NSU 50-20N2C-NSU	1089-150 1089-158	24" wide 76" high with doors open 30 1/8" deep	353 lbs. (steam) 303 lbs. (elec.)
1	Detergent Dispenser	DR-100		5 lbs.
1	Rinse Injector	RI-300		5 lbs.
1	Booster (electric) (steam)	C-9 D-2526		118 lbs. 110 lbs.
2	Cleanout Brushes	Commercial tubular, hard copper alloy, 26" long, with brush part 6" long and 3/4" diam.		

NOTE: The equipment specified in this table is shipped in one (1) crate; overall dimensions of the crate are 49L x 78H x 39W. Weight of the crate and machine is 418 lbs. for the steam-heated machine and 486 lbs. for the electrically heated machine.

INSTALLATION AND LAYOUT DETAIL

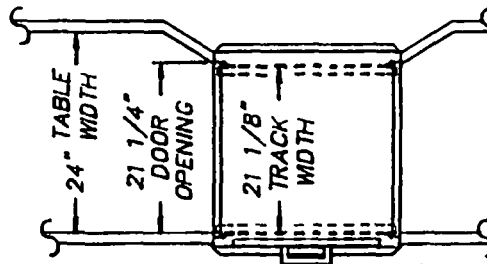
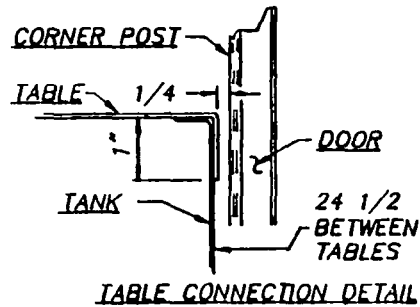

INSTALLATION CONNECTIONS		
LTR	DESCRIPTION	SIZE
B	HOT WATER TO ELEC. BOOSTER - 140° F	1/2 FIPS
F	DRAIN CONNECTION	1 1/2 FIPS
I	ELECTRICAL CONNECTION	1 HP *
J	ELECTRICAL CONNECTION - BOOSTER	9 KW **

- * ADD 3 KW FOR ELECTRIC HEAT.
- ** 15 KW FURNISHED WHEN SPECIFIED.

NOTES:

1. WASH TANK IS FILLED THRU THE FINAL RINSE LINE.
2. MAGNETIC STARTER WITH OVERLOAD FURNISHED MOUNTED AND INTERWIRED.
3. BOOSTER INSTALLATION CONNECTIONS ARE FOR 9KW ELECTRIC BOOSTER.
4. DISHWASHER CAN PASS THROUGH A 26" x 66" HATCH.
5. DISHWASHER MEETS REQUIREMENTS OF 00-D-1390A & PAR. 6.7 (SHIPBOARD OPERATION)

1-4

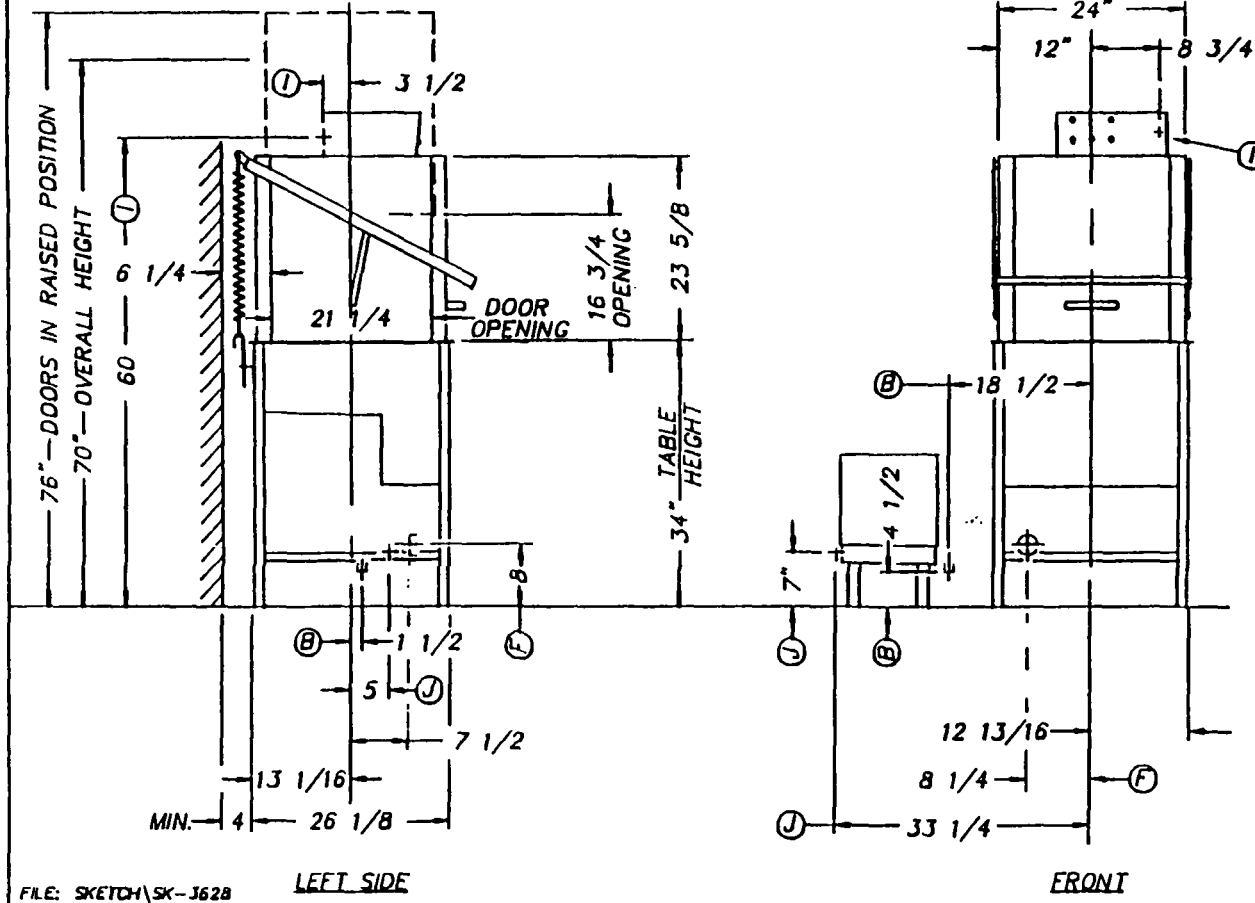

FILE: SKETCH\SK-3628

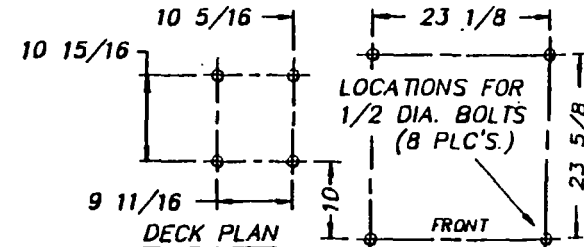

* FOR NON-MAGNETIC MACHINE ADD SUFFIX NM

50-20N2-NSU * AUTOMATIC DISHWASHING MACHINE	
 INSINGER MACROBLOC COMPANY	
6245 State Rd. Tel. 215-624-4800 Philadelphia PA 19135-2996 FAX: 215-624-6968	
SCALE: 3/4" = 1'-0"	DWG. NO.
DRAWN: MFJ 7.1.94	SK-3628
APPROVED: RAC 7.1.94	

1-5/(1-6 blank)

INSTALLATION AND LAYOUT DETAIL

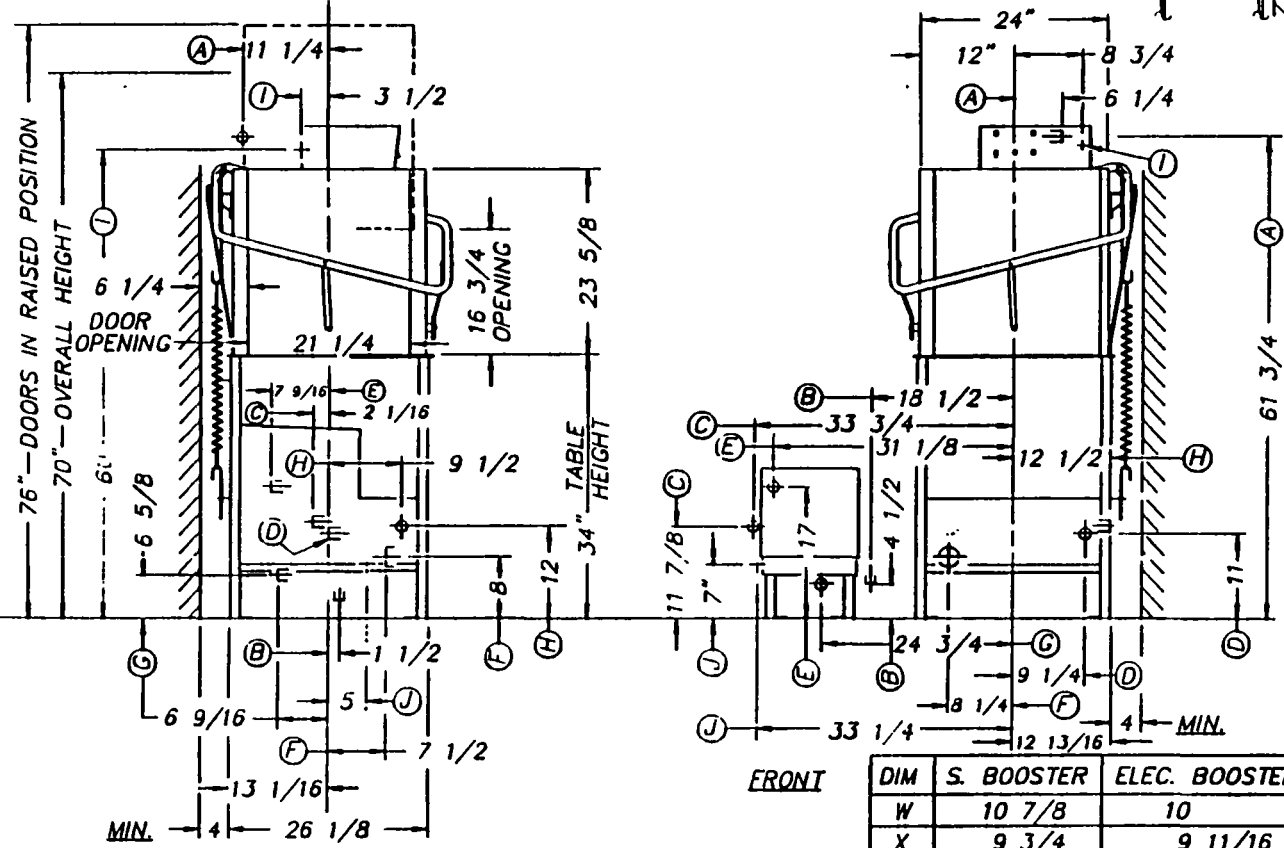
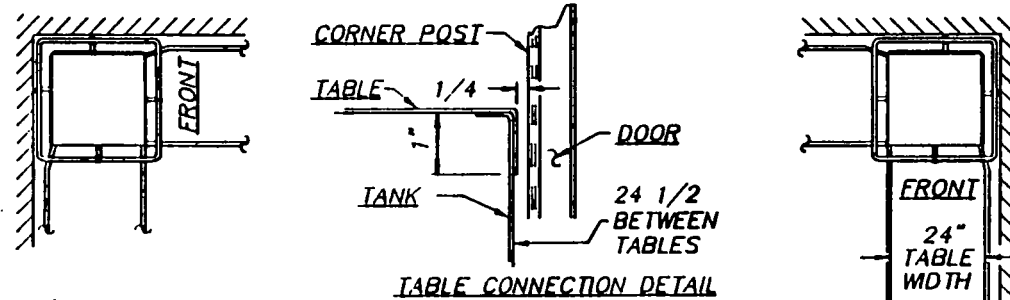

INSTALLATION CONNECTIONS		
LTR	DESCRIPTION	SIZE
A	HOT WATER TO FINAL RINSE - 180° F	1/2 FIPS
B	HOT WATER TO ELEC. BOOSTER - 140° F	1/2 FIPS
C	HOT WATER TO STEAM BOOSTER - 140° F	1/2 FIPS
D	STEAM TO TANK	1/2 FIPS
E	STEAM TO BOOSTER	1/2 FIPS
F	DRAIN CONNECTION	1 1/2 FIPS
G	CONDENSATE RETURN - BOOSTER	3/8 FIPS
H	CONDENSATE RETURN - COIL	3/8 FIPS
I	ELECTRICAL CONNECTION	1 HP *
J	ELECTRICAL CONNECTION - BOOSTER	9 KW **

* ADD 3 KW FOR ELECTRIC HEAT.
** 15 KW FURNISHED WHEN SPECIFIED.

- NOTE:**
1. WASH TANK IS FILLED THRU THE FINAL RINSE LINE.
 2. MAGNETIC STARTER WITH OVERLOAD FURNISHED MOUNTED AND INTERWIRED.
 3. BOOSTER INSTALLATION CONNECTIONS SHOWN ARE FOR INSINGER STEAM HEAT EXCHANGE STYLE BOOSTER OR 9KW ELECTRIC BOOSTER.
 4. DISHWASHER CAN PASS THRU A 26" x 66" HATCH WITH DOOR HANDLE REMOVED.
 5. DISHWASHER MEETS REQUIREMENTS OF 00-D-1390A & PAR. 6.7 (SHIPBOARD OPERATION).

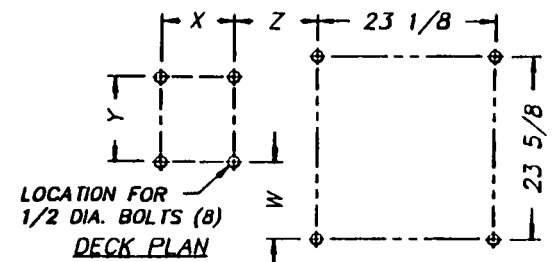

* FOR NON-MAGNETIC MACHINE ADD SUFFIX NM.

50-20N2-NSU (CORNER MODEL)
AUTOMATIC DISHWASHING MACHINE

DIM	S. BOOSTER	ELEC. BOOSTER
W	10 7/8	10
X	9 3/4	9 11/16
Y	12 3/4	10 15/16
Z	8 5/16	10 5/16

INSINGER
MACEBO COMPANY

6245 State Rd. Tel. 215-624-4800
Philadelphia TWX: 710-670-1233
PA 19135-2996 FAX: 215-624-6966

SCALE: 3/4" = 1'-0"
DRAWN: RAF 06.22.87
APPROVED: RAC 06.22.87

DWG. NO. 8768

FIGURE 2. CORNER MODEL

FILE: /INSTAL87/8768

▲ ECN #658 6.3.92 EBA

CHAPTER 2

OPERATION

2.1 INTRODUCTION

2.1.1 The purpose of this chapter is to identify the components of Insinger 50-20N2(C)-NSU dishwashers and describe the controls and operating procedures for their use.

2.1.2 The 50-20N2(C)-NSU dishwasher system is designed to be conveniently operated by one person. The washer system operates either against the bulkhead, or in a corner, depending on the model ordered. Most of the controls and all of the indicators are located in a top-mounted control box. All of the gauges are located, for ease of visibility, on the top of the washing machine. The operator loads the rack, closes the door, and starts the system for washing. The rack is removed after the final rinse operation. For steam-heated machines, the steam booster/heat exchanger is located beneath the wash tank, on the base frame. It has two manually operated valves to permit flow of hot water and steam. No other controls or indicators are located on the steam booster/heat exchanger. The electric booster is automatically controlled and is located to the side of the machine (usually beneath an end user supplied table).

2.1.3 Figures 1 and 2 (pages 1-4 and 1-5) illustrate the components discussed above and indicate the location of many of the controls and indicators described in this chapter. Figure 13 (page 9-5) illustrates the controls and indicators located on the control panel. Refer to these figures while proceeding through the descriptions.

2.2 CONTROLS AND INDICATORS

2.2.1 STEAM BOOSTER/HEAT EXCHANGER (steam-heated machines only). There are two manually operated valves on the steam booster. In the ON position these valves supply hot water and steam to the booster.

2.2.2 50-20N2(C)-NSU Dishwasher CONTROL PANEL. The panel is illustrated in Figure 13. It contains the following controls and indicators:

- a. Power Switch - ON/OFF toggle switch activates the machine.
- b. Power ON Indicator - RED light to verify that power has been applied to the machine.
- c. WASH Indicator - WHITE light illuminates when machine is in WASH period of cycle.

- d. RINSE Indicator - AMBER light illuminates when machine is in RINSE period of operating cycle.
- e. Reset Button - 5 amp circuit breaker button that can be depressed to reset system after current overload and subsequent elimination of the cause of the overload.

2.2.3 TEMPERATURE AND PRESSURE GAUGES. There are two temperature and two water pressure gauges associated with the 50-20N2(C)-NSU dishwasher. The wash tank temperature gauge is located on the machine top, front. The final rinse temperature gauge and water pressure gauge are located on the machine top, rear, on the final rinse piping. The pump pressure gauge is located below the tank on the pump housing.

2.2.4 TANK WATER LEVEL. The water level indicators are located on the front of the 50-20N2-NSU dishwasher directly below the inspection doors. This location permits monitoring of the tank water level. The 50-20N2C-NSU has no level indicators since no tank surfaces are exposed.

2.2.5 DETERGENT HOLDER, DISPENSER AND RINSE INJECTOR. Detergent is automatically dispensed into the dishwasher system through the detergent dispenser located on the top of the washer above the wash compartment. The dispenser contains a warning light and sound alarm to indicate insufficient detergent in the system. It also contains a power indicator to verify that the dispenser is turned on. The dispenser is turned on by the power switch on the 50-20N2(C)-NSU dishwasher control panel. The ON/OFF pushbutton located on the dispenser should remain in the ON position.

2.3 OPERATING PROCEDURES

2.3.1 50-20N2(C)-NSU DISHWASHER PREPARATION. The following steps are necessary to prepare the 50-20N2(C)-NSU dishwasher for operation:

- a. Raise the inspection doors to the wash compartment. Check that the spray manifolds are securely installed and that the plastic caps at the end of each arm are secure. Check that the scrap screens are secure.
- b. Pull out the scrap screen to gain access to the wash tank. Check that the drain overflow valve is properly seated in the drain seat. Replace the scrap screen securely.
- c. Close the drain valve underneath the wash tank by turning it to the right.
- d. Check that the water valve is open and that the main electrical power is connected.

- e. Check that all doors are closed.

CAUTION

Only washing detergent and amounts specified in BuShips publication NavShips 250-522, titled: "Operation and Maintenance of Dishwashing Machines," may be used in this dishwasher.

- f. Add sufficient washing compound to reach the FILL line of the detergent holder on the 50-20N2(C)-NSU dishwasher.

NOTE

Detergent will be automatically dispensed when the machine is started. Automatic dispensing will continue through the washing operation until the dispenser is empty. The dispenser empty indicator will illuminate and a sound alarm will be activated when the dispenser is empty.

2.3.2 TANK FILL. The following steps are necessary to fill the tank:

- a. On the steam and electric boosters, turn the water supply valve levers to the ON position, parallel with the pipes. On the steam booster only, the steam supply valve must also be turned ON.
- b. Close the drain.
- c. On the 50-20N2(C)-NSU dishwasher control panel, turn power switch ON. The tank is filled through the final rinse manifold automatically.

NOTE

If any of the above indications are missing, flip the power switch to OFF then refer to the maintenance section of this manual.

- d. Monitor temperature by viewing Wash and Rinse temperature gauges on top of the washer.

NOTE

Recommended temperature ranges are as follows:

Wash > 165 °F
Final Rinse > 180 °F

WARNING

Inspection doors must be closed during operation.

Do not open detergent dispenser while machine is in operation. If more washing compound is needed, shut machine down before adding additional detergent.

2.3.3 LOAD 50-20N2(C)-NSU DISHWASHER. Lift the two side doors, and position the rack in the machine.

2.3.4 UNLOAD 50-20N2(C)-NSU DISHWASHER.

WARNING

Washware exiting the machine is very hot. Care must be taken during unloading.

2.3.5 SHUT DOWN 50-20N2(C)-NSU DISHWASHER. The following steps are necessary to shut down the 50-20N2(C)-NSU dishwasher:

- a. After all washware has been washed, flip the POWER toggle switch to the OFF position.

NOTE

If shutdown is being accomplished in order to add detergent, the detergent can be added at this point.

- b. Monitor temperature gauges to verify that the tanks have cooled down.
- c. On the steam booster, turn the water and steam supply valve levers to the OFF position.

2.3.6 DRAIN AND CLEAN 50-20N2(C)-NSU DISHWASHER. The following steps are required to drain and clean the 50-20N2(C)-NSU dishwasher:

WARNING

Before opening the wash and rinse tank drains on the 50-20N2(C)-NSU dishwasher make sure the tank temperatures have cooled down to below 120 °F and that the entire system has been shut down.

Electrical equipment must be turned off before servicing.

- a. Underneath the 50-20N2(C)-NSU dishwasher, open the drain for the wash tank. Allow tank to drain.
- b. Open the doors to the wash compartment. Remove scrap screen and clean out.
- c. Take manifolds out, take off end caps and clean out tubes with the brush provided. Replace end caps securely. Replace manifolds.
- d. Wipe out interior of wash compartment.
- e. Remove overflow drain and clean out tank and drain.
- f. Remove plastic suction strainer grate at bottom of tank over recirculating pump. Clean out and replace.
- g. Replace overflow drain securely in its seat.
- h. Replace scrap screen on tank.
- i. Leave inspection door on wash compartment open.
- j. Close the drain underneath the wash tank.

CHAPTER 3

FUNCTIONAL DESCRIPTION

3.1 INTRODUCTION

The purpose of this chapter is to describe how the Insinger 50-20N2(C)-NSU dishwasher system works.

3.2 DESCRIPTION OF EQUIPMENT OPERATION

The 50-20N2(C)-NSU dishwasher system permits quick and efficient cleaning of washware, loaded into standard 20" racks, used on board Navy ships. Racks are loaded by the operator into the wash compartment. During the wash operation, the washware is subjected to an inundating spray of 150 to 170 °F water. The water employed in the wash operation contains the appropriate concentration of a washing compound. Dirt and debris leaving the washware is collected by the scrap screen. After washing, each rack is subjected to a rinse operation where the soap and any remaining dirt and debris is cleaned off by 165 to 185 °F water. The final rinse then sanitizes the washware with a continuous stream of 180 to 190 °F water. After the final rinse operation the racks can be unloaded. The washer system comes with a booster, either steam or electric, and an automatic detergent dispenser. Required shipload supplies (water pressure, steam, drainage) are specified in Table 1 (page 1-2).

CHAPTER 4

SCHEDULED MAINTENANCE

4.1 INTRODUCTION

4.1.1 This chapter describes the scheduled maintenance required for the Insinger 50-20N2(C)-NSU dishwasher.

WARNING

Electrical equipment must be turned off before servicing.

4.1.2 The Insinger 50-20N2(C)-NSU dishwasher has sealed bearings that require no lubrication.

4.2 DESCRIPTION OF SCHEDULED MAINTENANCE TASKS

4.2.1 AFTER EACH OPERATION. Following each use of the 50-20N2(C)-NSU dishwasher system the system must be drained and cleaned in accordance with paragraph 2.3.6.

4.2.2 WEEKLY. Wipe down the superstructure using a good grade stainless steel cleaner. Rinse with clear water.

CAUTION

Do not hose down machine.

4.2.3 SEMIANNUALLY. Remove and replace strainer screens on steam lines and incoming water supply line. The procedure for this is as follows:

- a. Shut off water or steam supply.
- b. Loosen large hex nuts at bottom of strainer body in the water or steam line.
- c. Remove screen, inspect, clean or replace.
- d. Reassemble making sure that strainer screen is installed in proper direction. Use new gaskets to ensure a tight seal.

Inspect condition of valve seats and packing on supply valves and drain valves.

CHAPTER 5

TROUBLESHOOTING

5.1 INTRODUCTION

5.1.1 This chapter provides information useful for diagnosing and correcting unsatisfactory operation of the Insinger 50-20N2(C)-NSU dishwasher.

5.1.2 This chapter is supplemented by the procedures in Chapter 6, Corrective Maintenance.

5.2 TROUBLESHOOTING PROCEDURES

Troubleshooting for the Insinger 50-20N2(C)-NSU dishwasher has been broken down into symptoms, possible causes, checks and solutions. These are tabulated in Table 3.

TABLE 3

TROUBLESHOOTING AND SERVICE

SYMPTOM OF TROUBLE	POSSIBLE CAUSE	SOLUTION
1. Tanks will not fill	<ul style="list-style-type: none"> a. Switch not turned on b. Supply water valve closed c. Defective ON/OFF switch d. Defective level control e. Defective solenoid valve f. Dirty or defective liquid level probe 	<ul style="list-style-type: none"> a. Turn switch on b. Open valve c. Replace switch d. Replace level controller board e. Replace solenoid valve f. Clean or replace liquid level probe
2. Machine will not operate	<ul style="list-style-type: none"> a. No power b. Blown fuse or breaker c. Power shut off at disconnect switch d. Reset overload protection 	<ul style="list-style-type: none"> a. Check power supply b. Replace fuse, trip breaker c. Check disconnect switch for power d. Press reset button
3. Tank will not hold water	<ul style="list-style-type: none"> a. Petcock at pump is open b. Drain is not seating 	<ul style="list-style-type: none"> a. Close petcock b. Check for proper seating
4. Tank overflows - fills past overflow	<ul style="list-style-type: none"> a. Obstruction in overflow tube b. Clogged drain line 	<ul style="list-style-type: none"> a. Remove obstruction b. Open drain valve - if water still does not go down, drain line must be cleaned
5. Water leaks from around door	<ul style="list-style-type: none"> a. Doors are not seating b. Clogged spray pipes 	<ul style="list-style-type: none"> a. Check for proper seating b. Clean with brush provided
6. Weak or ineffective spray	<ul style="list-style-type: none"> a. Clogged spray pipes b. Improper placement, pipes spray inward. c. Foreign material caught in pump - may occur when machine is operated without suction strainer in place d. Reversed pump rotation 	<ul style="list-style-type: none"> a. Clean with brush provided b. Direct spray upwards c. Remove obstruction - rags or other foreign matter d. Arrow on pump housing indicates direction - correct electrically

TABLE 3

TROUBLESHOOTING AND SERVICE (continued)

SYMPTOM OF TROUBLE	POSSIBLE CAUSE	SOLUTION
7. Inadequate rinse spray	<ul style="list-style-type: none"> a. Lime deposits on spray nozzles b. Low water pressure c. Clogged line strainer d. Closed supply valve 	<ul style="list-style-type: none"> a. Clean nozzles b. Should be 15-20 PSI flowing c. Turn off water supply and clean strainer d. Open valve
8. Rinse will not shut off	<ul style="list-style-type: none"> a. Clogged rinse valve b. Worn disc and seat 	<ul style="list-style-type: none"> a. Turn off water supply, disassemble valve and clean internal parts of lime and scale b. Turn off water supply, disassemble valve and replace if necessary
9. Water hammer	<ul style="list-style-type: none"> a. Excess line pressure 	<ul style="list-style-type: none"> a. Turn off water supply, install or adjust pressure regulator - shock absorbing air chambers may be required
10. Machine vibrates	<ul style="list-style-type: none"> a. Worn bearings b. Reversed pump rotation 	<ul style="list-style-type: none"> a. Replace bearings b. Arrow on pump housing indicates direction - correct electrically
11. Tank and/or booster will not hold specified temperature	<ul style="list-style-type: none"> a. No power b. Burned out immersion heater(s) c. Defective Temp. Controller d. Defective temperature indicator e. Closed steam supply valve f. Clogged steam solenoid valve g. Worn solenoid disc and seat h. Clogged or airbound steam trap i. Clogged line strainer 	<ul style="list-style-type: none"> a. Check power supply b. Replace immersion heater(s) c. Replace either Controller board or diode junction d. Replace temperature indicator e. Open valve f. Turn off steam supply, disassemble valve and clean internal parts g. Turn off steam supply, disassemble valve and replace if necessary h. Turn off steam supply, clean, repair or replace i. Turn off steam supply and clean strainer

TABLE 3

TROUBLESHOOTING AND SERVICE (continued)

SYMPTOM OF TROUBLE	POSSIBLE CAUSE	SOLUTION
12. Poor washing results	a. Clogged screen b. Clogged pump suction strainer c. Clogged spraying arms	a. Shut it down, remove and clean b. Shut it down, remove and clean c. Shut it down, remove and clean

CHAPTER 6

CORRECTIVE MAINTENANCE

6.1 INTRODUCTION

6.1.1 This chapter provides step-by-step instructions for several repair and replacement procedures that may be necessary for the Insinger 50-20N2(C)-NSU dishwasher.

WARNING

Electrical equipment must be turned off before servicing.

6.1.2 This chapter supplements and extends the preceding chapter on Troubleshooting.

6.2 REPAIR AND REPLACE PROCEDURES

6.2.1 DISASSEMBLY OF SOLENOID VALVE.

- a. Disconnect electrical power supply to machine. Shut off water supply.
- b. Remove cap on top of coil.
- c. Remove coil.
- d. Unscrew four hex head bolts and lift out bonnet from valve body. Note positioning of spring and pilot plunger.
- e. Remove main piston.
- f. Inspect for dirt, wear, lime build-up or bent spindle. Clean or replace as required.
- g. Reassembly is reverse of disassembly procedure.

6.2.2 DISASSEMBLY OF RECIRCULATING PUMP.

- a. Before attempting to disassemble pump, it is advisable to remove suction cover (inside tank) and see if the trouble could be caused by a foreign object which may have been sucked into the inlet.

- b. Working parts of pump can be serviced by removing the pump motor and impeller adapter (held on by four 3/8" diameter hex head screws).

NOTE

It is not necessary to remove pump body from the machine.

- c. Repair or replace pump adapter as required. Always use a new O-ring whenever adapter assembly has been removed.

6.3 DIAGNOSIS, REPAIR AND REPLACE PROCEDURES

6.3.1 THERMOMETERS

- a. If a thermometer is suspected of being inaccurate, first check the tank temperature with another temperature gauge to compare readings. (If readings are approximately the same within a couple of degrees, then the problem is in the tank heat control.)
- b. Make sure that the thermometer that was used to check the water temperature is calibrated. If the results show that the gauge on the machine is reading more than 5 °F higher or lower, the gauge should be replaced.

NOTE

It is important that you place the test gauge capillary or sensor as close to the existing gauge's capillary for an accurate diagnosis.

- c. To replace gauge, loosen the nut which holds the capillary clamp at the bottom of the tank. Next loosen and remove the hold-down nut located at the top of the machine on the inside. Now the gauge can be removed. Install new gauge making sure to put a small amount of silicone or plumber's putty on the part of the gauge that mounts through the machine. Reverse the procedure for removal.

6.3.2 STEAM TEMPERATURE REGULATOR AND TRAPS. The steam temperature regulator is a mechanically operated thermostat used to control final rinse booster temperature. This regulator may be faulty if either excessive, or insufficient, temperature is encountered.

- a. Check incoming water supply temperature. Machine fill water and/or booster supply should be 140 °F minimum. Supply water temperatures below 140 °F will require a booster of greater capacity.

- b. On all steam boosters and on machines that have steam coils as tank heat, there is a condensate trap located under the steam booster or machine tank. Check to see if this valve is operating correctly, allowing steam to flow when the supply valve or steam regulator is open. A steam trap that is stuck shut, possibly due to corrosion, will not allow the steam to flow; therefore, no heat will be produced. A trap that is stuck open will cause excessive temperature all the time when the regulator allows steam through.
- c. When the temperature in the tanks exhibits excursions outside the specified range, or the regulator will not open at all, that regulator must be replaced.
- d. To replace regulator, first close all steam valves to this machine. Remove probe by loosening compression coupling. Then loosen and remove regulator unions. Reverse order to install new one.

6.3.3 SOLENOID VALVES. Solenoid valves are used on the machine for providing tank heat, in steam-heated machines, and final rinse water. If the valve in question will not close, or will not open, check these items:

- a. A solenoid valve is opened by an electromagnetic plunger which is energized when voltage is applied to its coil. Make sure you have voltage and the voltage on the coil matches the supply voltage. If the solenoid valve will not open and there is no voltage at the coil, the problem is somewhere in the temperature control circuit thermostat, ON/OFF switch, or in a case where the solenoid is used to control tank temperature, the liquid level control board, and float assembly.
- b. If the valve will not open and there is correct voltage to the solenoid coil, then check the coil. Disconnect all power to machine and remove coil. Visually check for signs of discoloration or carbon deposit due to the coil having been shorted out (burnt out) possibly from water leaking on the valve. Also check the coil winding with a meter for electrical continuity. Set meter on highest ohm scale. No continuity means an open coil and it must be replaced.
- c. Next check inside valve by removing four bolts which hold the top on. Visually check the rubber diaphragm for wear, deterioration, or holes. Also check the plunger. Make sure it is free and does not stick.

6.3.3.1 Repair kits are available to rebuild these valves. If the seat of the bottom half of the valve is worn or corroded badly, then the whole valve must be replaced.

6.3.3.2 Solenoid Valves used on 50-20N2(C)-NSU are:

- a. 1 each - 1/2" (Water) - Final Rinse
- b. 2 each - 3/4" (Steam) - Tank Heat for steam machines only

6.3.4 ELECTRONIC TEMPERATURE CONTROLLER

NOTE

Used on tank heat thermostat only.

- a. If a thermostat is found to be bad, it will neither open nor close the solenoid valve. This is indicated by low water temperature, excessive water temperature, or an inability to maintain water temperature within the specified range about the set point. This thermostat must be replaced.
- b. For the tank heat thermostat, disconnect the two wires leading to it, then remove the two mounting screws and then the capillary or sensing probe from the tank.

CHAPTER 7

PARTS LIST

7.1 REPLACEMENT PARTS LIST

The following pages contain information in diagrammatical form for the purpose of identifying replacement parts.

Fig. 3
Dishwasher, Model 50-20N2-NSU (Standard)

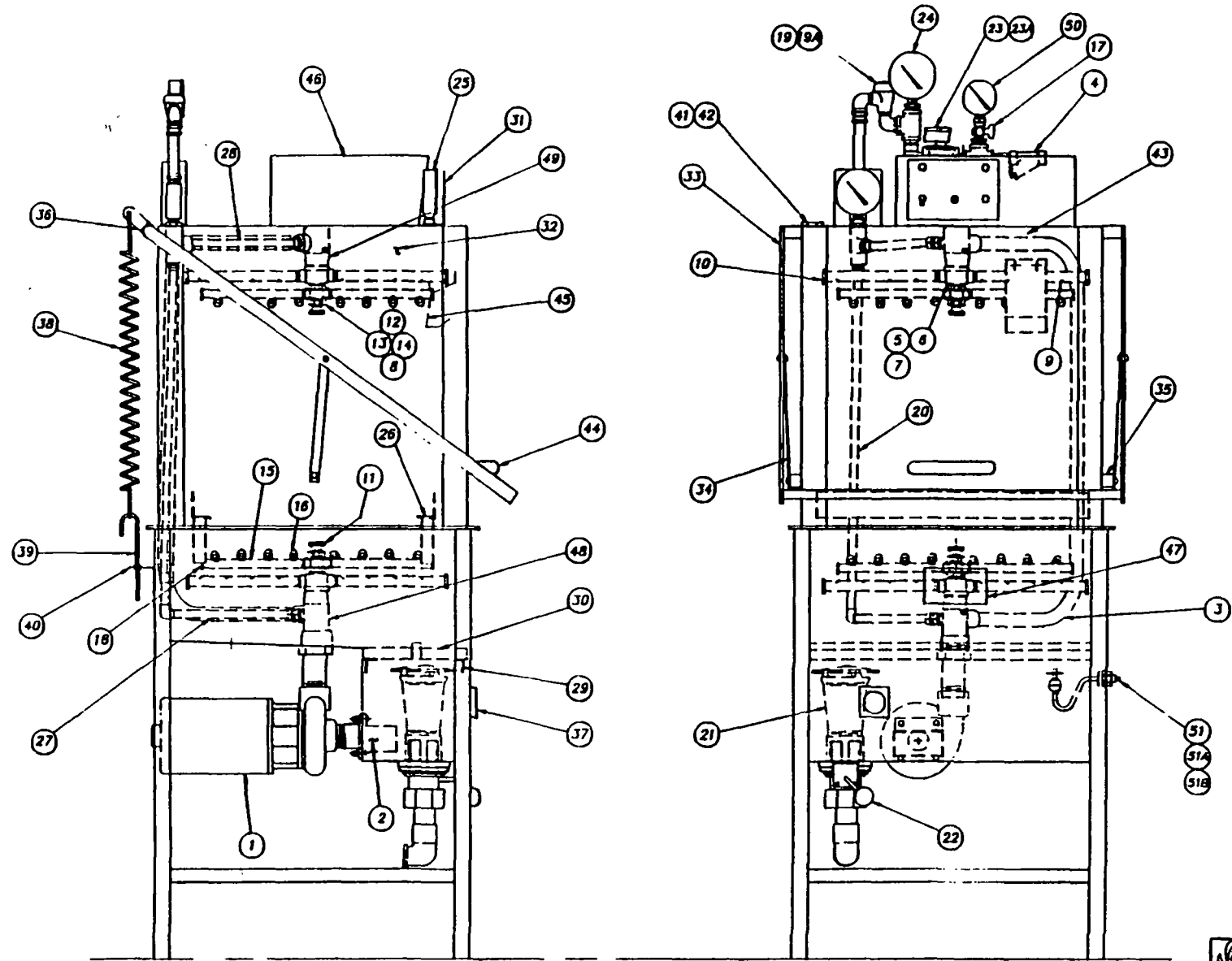

SIDE

FRONT

7-2

FILE: SKETCH\SK-28391

△ ECN# 1030 7.19.94

SK-2839 SHEET 1 OF 2
 Philadelphia, PA 19135
 (215) 624-4800
 FAX (215) 624-8966
 50-20N2-NSU

PARTS LIST - COMMANDER 18-3

ITEM	PART NO.	DESCRIPTION	REQ.
1	D-2465	PUMP & MOTOR ASS'Y (1 H.P. - SPECIFY VOLTAGE)	1
2	1089-20 rev.B	SUCTION COVER	1
3	1089-13	DISCHARGE LINE ASS'Y	1
4	D-2483A ✓	"Y" STRAINER, 1/2	1
	1089-25	SPINNER ASS'Y. - WASH.	(2 REF.)
5	1084-76	SPRAY HUB - WASH ✓	2
6	D2-56J	O-RING	2
7	952-27	BUSHING	2
8	1089-178	BUSHING, PLASTIC	2
9	1089-23	SPRAY PIPES	4
	1089-26	SPINNER ASS'Y. - RINSE	(2 REF.)
10	D2-554-2	PLUG, 3/4-10 UNC-2A	4
11	D2-584	LOCKING SCREW	2
12	1084-22	SPRAY HUB - RINSE	2
13	1084-35 ✓	BUSHING - UPPER	2
14	1084-36 ✓	BUSHING - LOWER	2
15	1089-24 rev.B	SPRAY PIPE - RINSE	2 ea.
16	D-2701	SPRAY NOZZLE - RINSE	16
17	D-2497 -	PETCOCK	1
18	D2-554-1	PLUG, 9/16-12 UNC-2A	4
19	D-2241A -	VACUUM BREAKER, 1/2	1
19A	D-2242A	VACUUM BREAKER REPAIR KIT	1
20	1089-J1C	FINAL RINSE PIPING ASS'Y (VERTICAL)	1
21	954-50	DRAIN ASS'Y ✓	1
22	1100-79	DRAIN HANDLE ASS'Y	1
23	D-2606 -	SOLENOID VALVE, 1/2	1
23A	D-2641	SOLENOID VALVE REPAIR KIT	1
24	D-2495 -	TEMPERATURE GAUGE - FINAL RINSE ✓	1
25	D-2390 -	TEMPERATURE GAUGE ✓	1
26	1084-14A	TRACK ASS'Y	2
27	1089-J1B	FINAL RINSE PIPING ASS'Y (LOWER)	1
28	1089-J1A	FINAL RINSE PIPING ASS'Y (UPPER)	1
29	1089-9	TRAY SUPPORT	2
30	1089-10	SCRAP SCREEN	1
31	D2-754A	GUARD TEMP. GAUGE	1
32	1089-8	DOOR - SIDE	2
33	1084-26	DOOR ARM	1
34	1089-154	LINK - DOOR ARM	2
35	957-26	SPACER - DOOR ARM LINK	2
36	1084-39	PIVOT BRACKET - DOOR ARM	2
37	D924C	WATER LEVEL INDICATOR	1
38	SK-2294A	SPRING	2
39	957-27	SPRING EXTENSION - LOWER	2
40	1089-12	SPRING BRACKET	1
41	DE5-37 ✓	SWITCH, MAGNETIC	1
42	DE5-37A	MAGNET	1
43	1089-57	DOOR - FRONT	1
44	D-2099 -	DOOR HANDLE	1
45	1089-59	DOOR HANGER	1
46	SK-2833	CONTROL BOX ASS'Y	1
47	SK-2709	NSF DATA PLATE	1
48	1089-16A	MANIFOLD ASS'Y, LOWER	1
49	1089-15A	MANIFOLD ASS'Y, UPPER	1
50	D-100J -	PRESSURE GAUGE	1
51	DE5-60	LIQUID LEVEL FLOAT	1 ST., 2 EL. & GAS
51A	1089-188	WASHER	1
51B	D312C-NC-2	HEX NUT	1

SK-2839

SHEET 2 OF 2

PARTS LIST - 50-20N2-NSU NM

<u>ITEM</u>	<u>PART NO.</u>	<u>DESCRIPTION</u>	<u>REQ.</u>
1	D2669	Bronze Pump/Motor Ass'y (1 hp)	1
2	1089-20	Suction Cover	1
3	1089-13	Discharge Line Ass'y.	1
4	D-2482	"Y" Strainer 3/4	1
	1089-25	Spinner Ass'y. - Wash.	(2 Ref.)
5	1084-76	Spray Hub-Wash	2
6	952-27	Bushing	2
7	1089-23	Spray Pipes	4
8	D2-554-2	Plug 3/4-10 UNC - 2A	4
9	952-28A	Locking Screw	2
	1089-26	Spinner Ass'y. - Rinse	(2 Ref.)
10	372-52	Spray Hub-Rinse	2
11	1084-35	Bushing - Upper	2
12	1084-36	Bushing - Lower	2
13	1089-24	Spray Pipes - Rinse	2 ea.
14	D-2286A	Spray Nozzles - Rinse	8
15	D2-554-1	Plug 9/16 - 12 UNC - 2 A	4
16	D-2243	Vacuum Breaker 3/4	1
17	D-2244	Vacuum Breaker Repair Kit	1
18	1089-31C	Final Rinse Piping Ass'y. (Vertical)	1
19	954-1A	Drain Ass'y.	1
20	1100-79	Drain Handle Ass'y	1
21	D-2397	Solenoid Valve 3/4"	1
22	D-2495R	Temp. Gauge - Final Rinse	1
23	D-2390	Temperature Gauge	1
24	D2-754A	Guard Temp. Gauge	1
25	1084-14A	Track Ass'y.	2
26	1089-31B	Final Rinse Piping Ass'y. (Lower)	1
27	1089-31A	Final Rinse Piping Ass'y. (Upper)	1
28	1089-9	Tray Support	2
29	1089-10	Scrap Screen	1
30	1089-17	Bracket - Microswitch	1
31	1089-3	Door	2
32	1084-26	Door Arm	1
33	1089-154	Link - Door Arm	2
34	957-26	Spacer - Door Arm Link	2
35	1084-39	Pivot Bracket - Door Arm	2
36	D-2215A	Microswitch	1
37	SK-2294A	Spring	2
38	957-27	Spring Extension- Lower	2
39	1089-12	Spring Bracket	1
40	SK-2833	Control Box Assembly	1
41	DES-37	MAGNET/SWITCH	1

*Specify voltage or
see Product Data Sheet

 Insinger Machine Company		6245 State Road Philadelphia PA 19135-2996	Telephone 215-624-4800 TWX: 710-670-1233
DRAWN: <u>SG Bumsf</u>	DWG. NO. <u>SK 2987</u>		
CHECKED:			
APPROVED:			

Fig. 4. Dishwasher, Model 50-20N2C-NSU (Corner)



SIDE

FRONT

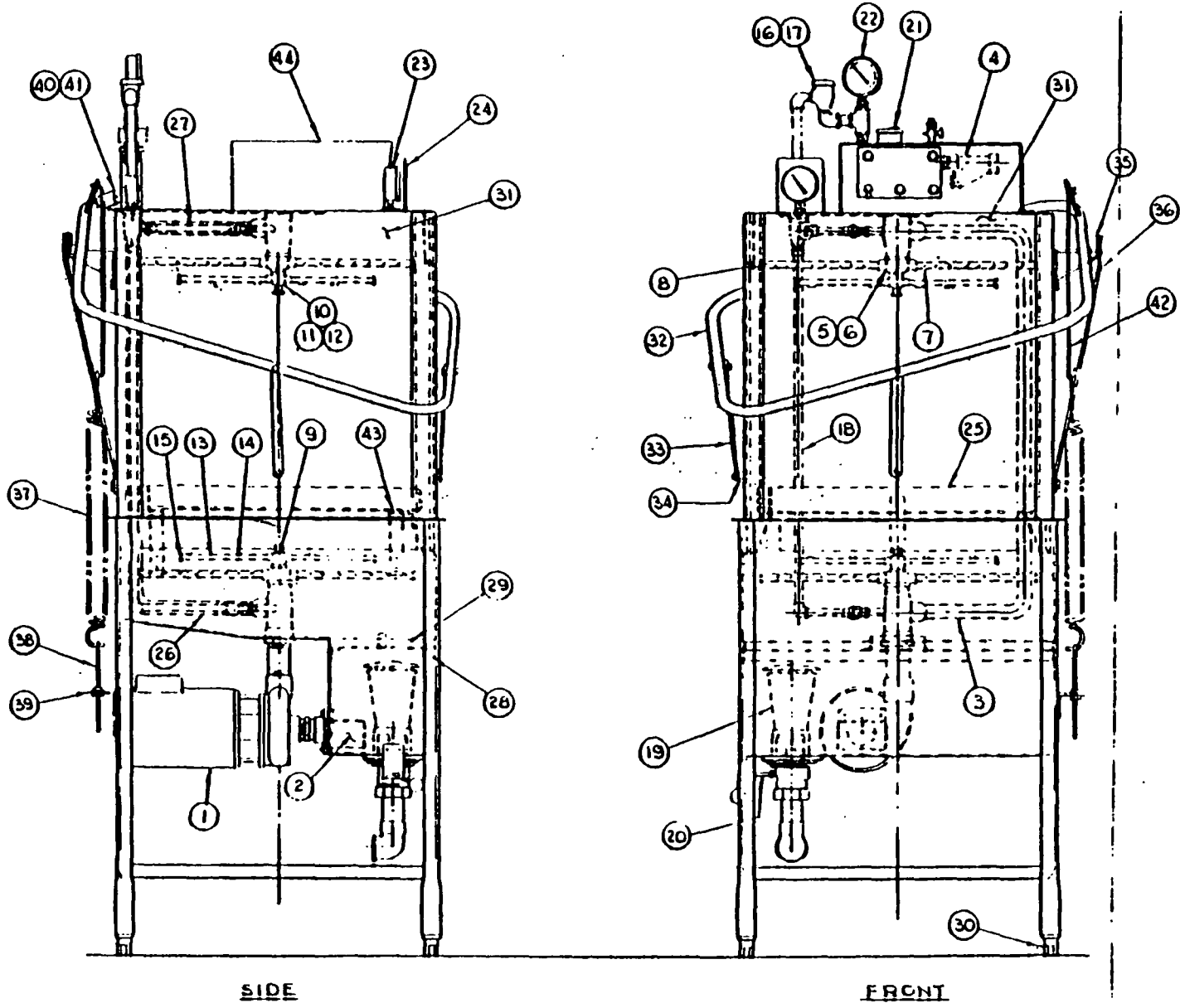
7-5

SK-2837

PG. 1 OF 2

INSINGER MACHINE CO.
PHILA. PA 19135 (215) 624 4800

PARTS LIST - 50-20N2C-NSU (Corner Model)

<u>ITEM</u>	<u>PART NO.</u>	<u>DESCRIPTION</u>	<u>REQ.</u>
1	D-2465	Pump & Motor Ass'y. (1 HP)*	1
2	1089-20	Suction Cover	1
3	1089-111	Discharge Line Ass'y.	1
4	D-2483A	"Y" Strainer 1/2	1
	1089-25	Spinner Ass'y. - Wash.	(2 Ref.)
5	1084-76	Spray Hub-Wash	2
6	952-27	Bushing	2
7	1089-23	Spray Pipes	4
8	D2-554-2	Plug 3/4-10 UNC - 2A	4
9	952-28A	Locking Screw	2
	1089-26	Spinner Ass'y. - Rinse	(2 Ref.)
10	372-52	Spray Hub-Rinse	2
11	1084-35	Bushing - Upper	2
12	1084-36	Bushing - Lower	2
13	1089-24	Spray Pipes - Rinse	2 ea.
14	D-2286 A	Spray Nozzles - Rinse	8
15	D2-554-1	Plug 9/16 - 12 UNC - 2 A	4
16	D-2241A	Vacuum Breaker 1/2	1
17	D-2242A	Vacuum Breaker Repair Kit	1
18	1089-31C	Final Rinse Piping Ass'y. (Vertical)	1
19	954-1A	Drain Ass'y.	1
20	1100-79	Drain Handle Ass'y	1
21	D-2450	Solenoid Valve 1/2	1
22	D-2495 R	Temp. Gauge - Final Rinse	1
23	D-2390	Temperature Gauge	1
24	D2-754A	Guard Temp. Gauge	1
25	1089-107	Track Ass'y.	1
26	1089-31B	Final Rinse Piping Ass'y. (Lower)	1
27	1089-31A	Final Rinse Piping Ass'y. (Upper)	1
28	1089-9	Tray Support	2
29	1089-10	Scrap Screen	1
30	D-2430	Bullet Foot (Commercial Only)	4
31	1089-8	Door - Side	2
32	1084-126	Door Arm	1
33	1084-119	Link - Door Arm	2
34	957-26	Spacer - Door Arm Link	2
35	952-118	Pivot Bracket - Door Arm	2
36	952-139	Support - Pivot Bracket	2
37	SK-2294A	Spring	2
38	957-27	Spring Extention- Lower	2
39	1089-118	Spring Bracket	1
40	1084-137	Bracket - Microswitch	1
41	D-2215A	Microswitch	1
42	957-49	Spring Extension - Upper	2
43	1089-108	Corner Track	1
44	SK-2833	Control Box Assembly	1

SK-2837

<p>INSINGER MACHINE CO. PHILA. PA. 19135 (215) 624-4800</p>

*Specify voltage or
see Product Data Sheet

RAF 5.22.87

PG. 2 OF 2

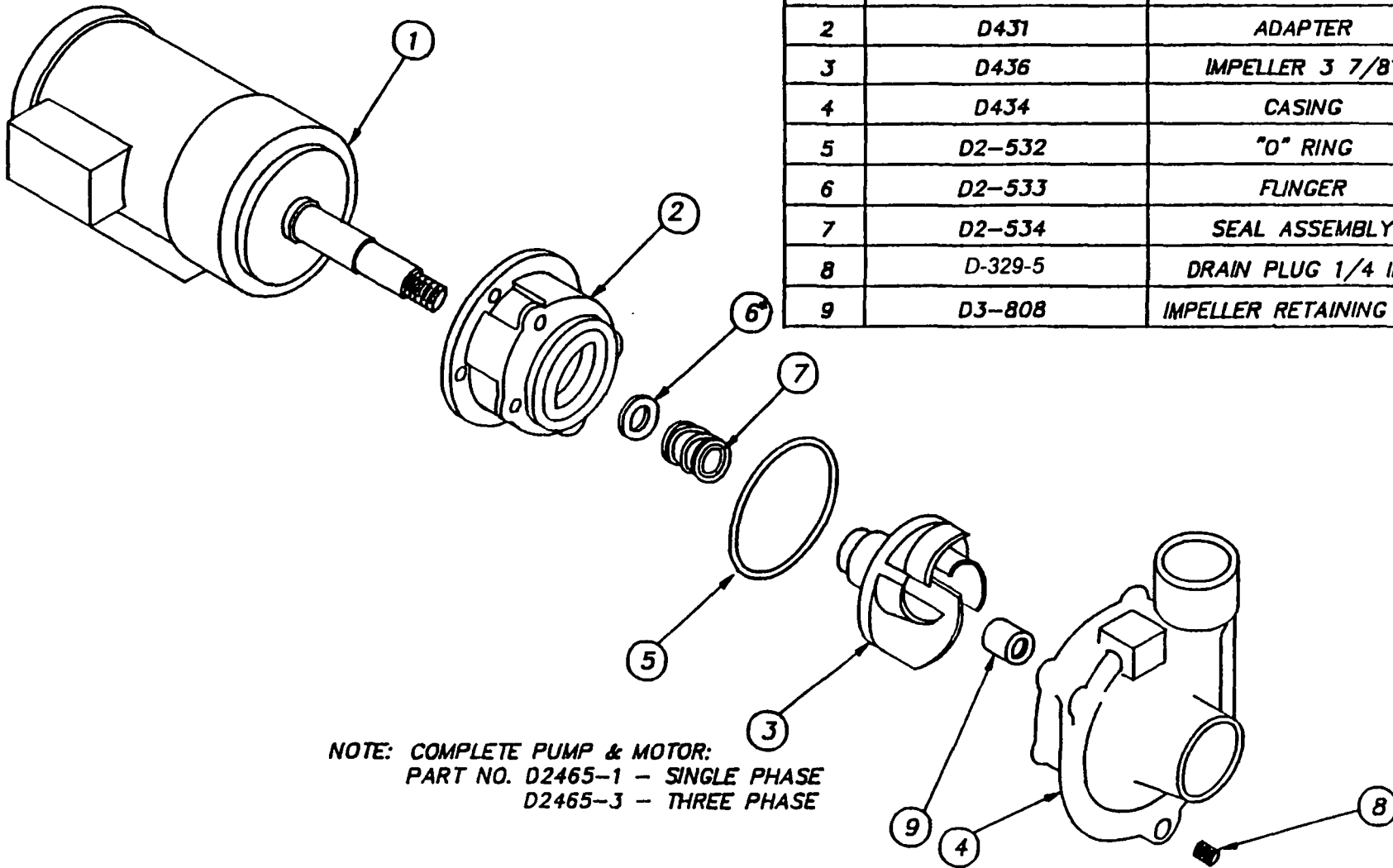

NOTE: COMPLETE PUMP & MOTOR:
 PART NO. D2465-1 - SINGLE PHASE
 D2465-3 - THREE PHASE

ITEM	PART NO.	DESCRIPTION	QTY.
1		MOTOR 1 H.P.	1
2	D431	ADAPTER	1
3	D436	IMPELLER 3 7/8"	1
4	D434	CASING	1
5	D2-532	"O" RING	1
6	D2-533	FLINGER	1
7	D2-534	SEAL ASSEMBLY	1
8	D-329-5	DRAIN PLUG 1/4 IPS	1
9	D3-808	IMPELLER RETAINING NUT	1

			TOLERANCES	TITLE	PARTS LIST	NEXT ASSY	DWG. NO.
			FRACTIONS ±1/64		1 HP PUMP	REQ'D -	SK-2462
			DECIMALS			SCALE -	USED ON
			.XXX ± .005				VARIOUS
			.XX ± .01				
A	1005	4.26.94	ANGLES ±1/2°				
REV	ECN NO	DATE	UNLESS OTHERWISE SPECIFIED	Philadel 1 PA 19135 (215) 681-1800			DRWN/DATE

Fig. 5 1 HP Pump

7-8

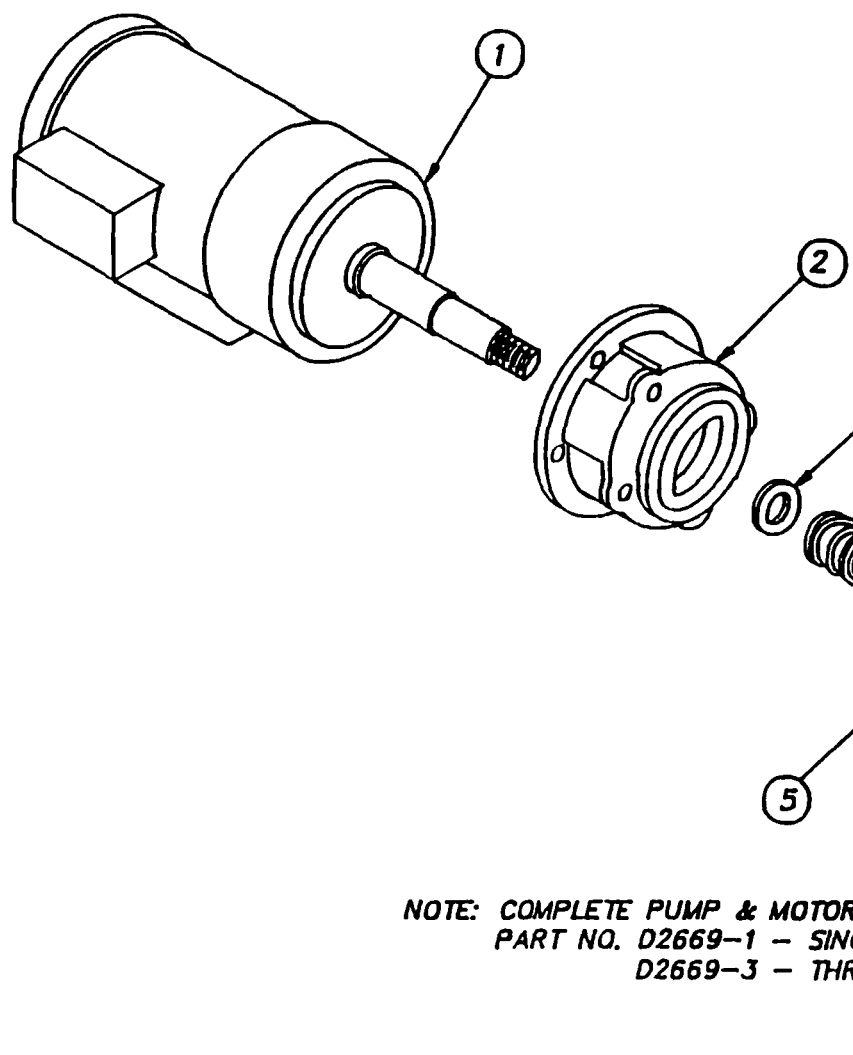

ITEM	PART NO.	DESCRIPTION	QTY.
1		MOTOR 1 H.P.	1
2	D431	ADAPTER	1
3	D2-160	IMPELLER 3 7/8"	1
4	D2-161	CASING	1
5	D2-532	"O" RING	1
6	D2-533	FLINGER	1
7	D2-534	SEAL ASSEMBLY	1
8	D-329-5	DRAIN PLUG 1/4 IPS	1
9	D3-808	IMPELLER RETAINING NUT	1

NOTE: COMPLETE PUMP & MOTOR:
 PART NO. D2669-1 - SINGLE PHASE
 D2669-3 - THREE PHASE

			TOLERANCES	TITLE	NEXT ASSY	DWG. NO.
			FRACTIONS ±1/64	PARTS LIST	REQ'D -	SK-2986
			DECIMALS			
			.XXX ± .005	MATL	SCALE -	USED ON
			.XX ± .01			VARIOUS
A	1021	6.24.94	ANGLES ±1/2"	Insinger Machine Company	Philadelphia, PA 19135 (215) 624-4800 FAX (215) 624-6966	
REV	ECN NO	DATE	UNLESS		ORWN/DATE	
			OTHERWISE		MAM	
FILE: SKETCHA \ SK-2986			SPECIFIED			6.29.94

Fig. 6 Drain Assembly

ITEM	PART NO.	PART NAME	QTY.
	954-50	DRAIN ASSY (COMPLETE)	-
1	954-50A	UPPER BODY	1
2	954-50B	LOWER BODY	1
3	954-50C	NUT	1
4	954-50D	OVERFLOW TUBE	1
5	D-19J	SKIMMER CAP	1
6	D2-557	V SEAL - DRAIN SEAT	1
7	954-9	O RING	1
8	D2-549	O RING	1
9	D-305	DRAIN JAM NUT	1
10	D2-550	O RING	1
11	1100-79	DRAIN HANDLE ASSY	1
12	954-8C	BRACKET	1
13	D-2507	BALL	1

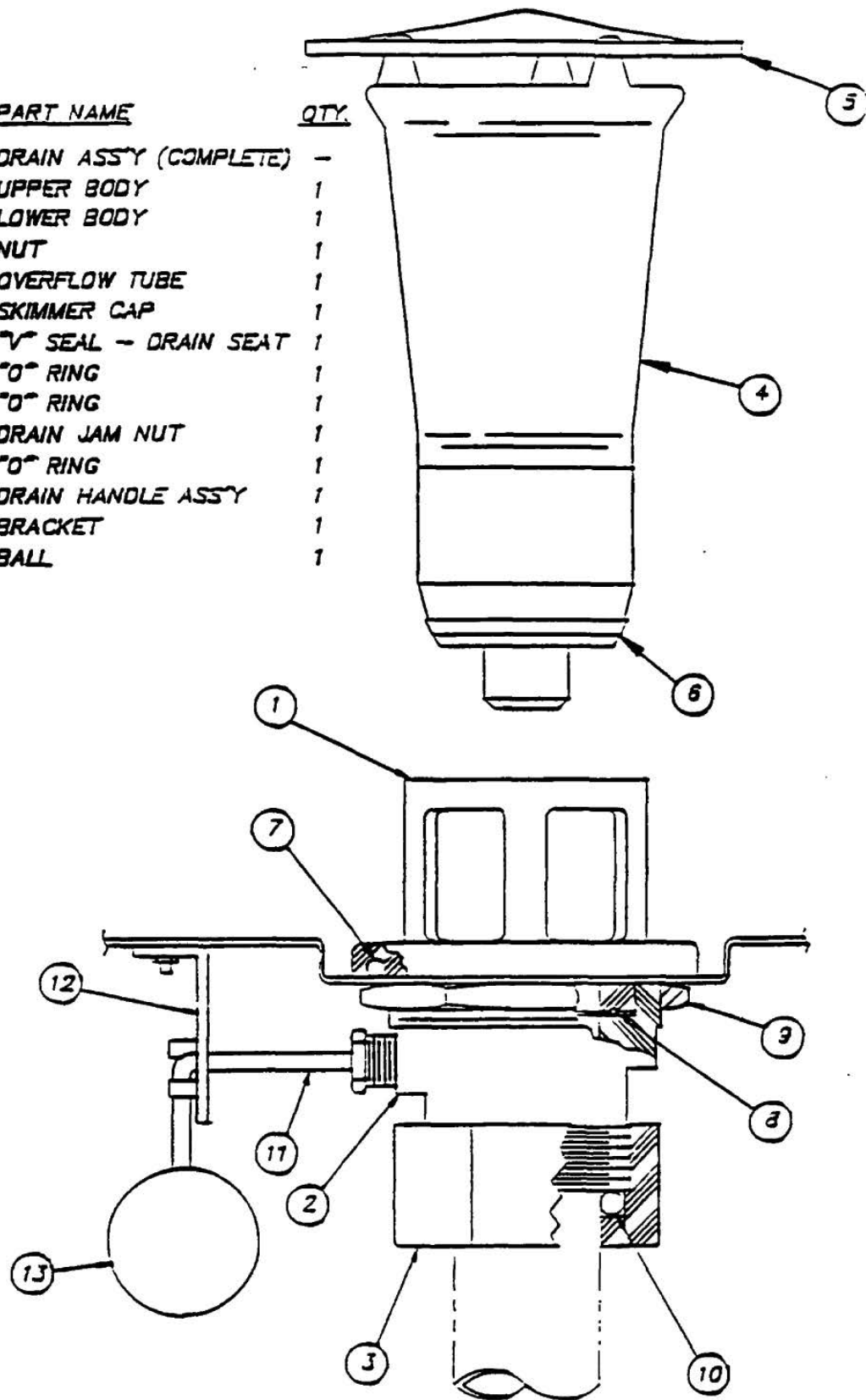

SK-3028

Fig. 7 - Steam Coil, Diode JCT, and Liquid Level Float Locations

NO.	DESCRIPTION	PART NO.	QTY.
1	STEAM COIL ASSY - COPPER	1089-32	1
2	STEAM COIL ASSY - S/S	1089-32A	1
3	LOCKNUT 1/2 IPS	D326A-D	2
4	NIPPLE 1/2 IPS X 4 1/2 LG. L.O.E.	D314A-D18-LOE	1
5	90° STREET ELL 1/2 MIPS X 1/2 FIPS	D316A-D1-D2	1
6	"Y" STRAINER 1/2 IPS	D-248JA	1
7	SOLENOID 1/2 IPS	D-2594	1
8	CLOSE NIPPLE 1/2 IPS	D314A-DCL	1
9	STEAM TRAP 3/8 IPS	D-2102	1
10	NIPPLE 1/2 IPS X 2 1/2 LG. L.O.E.	D314A-D10-LOE	1
11	RED. COUPLING 1/2 FIPS X 3/8 FIPS	DJ21A-D1-C1	1
12	90° STREET ELL 3/8 IPS	D316A-C1-C2	1
13	CLOSE NIPPLE 3/8 IPS	D314A-CCL	1

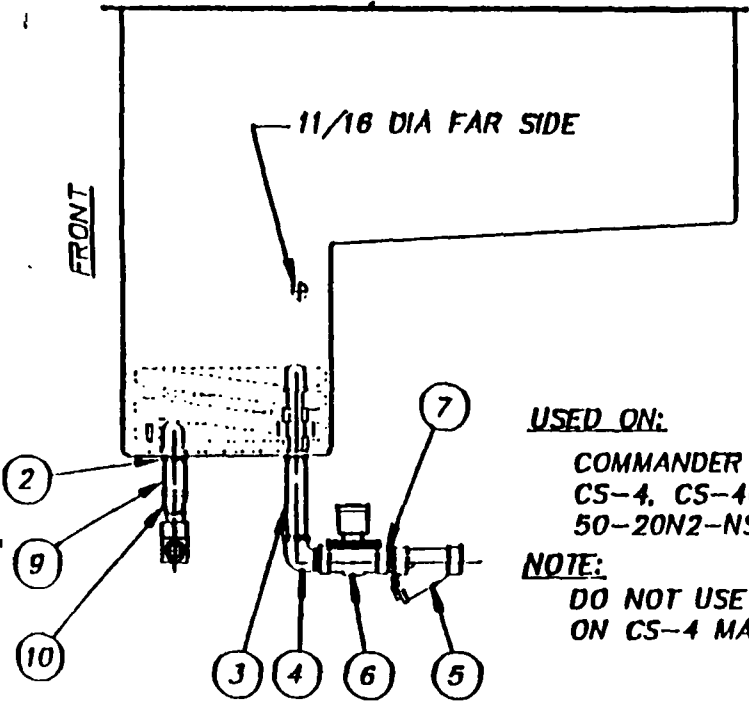
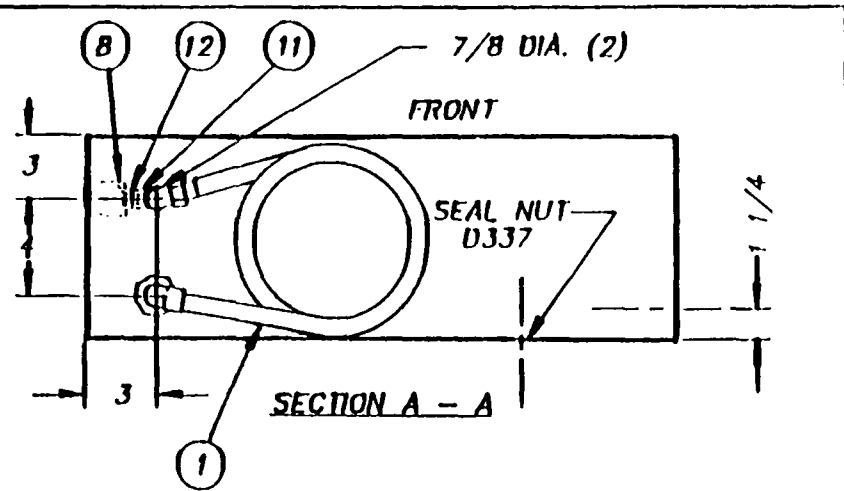

USED ON:
 COMMANDER 18-3, 18-3C,
 CS-4, CS-4C, 50-20N2-NSU,
 50-20N2-NSU (CORNER MODEL)

NOTE:
 DO NOT USE COPPER COIL
 ON CS-4 MACHINES.

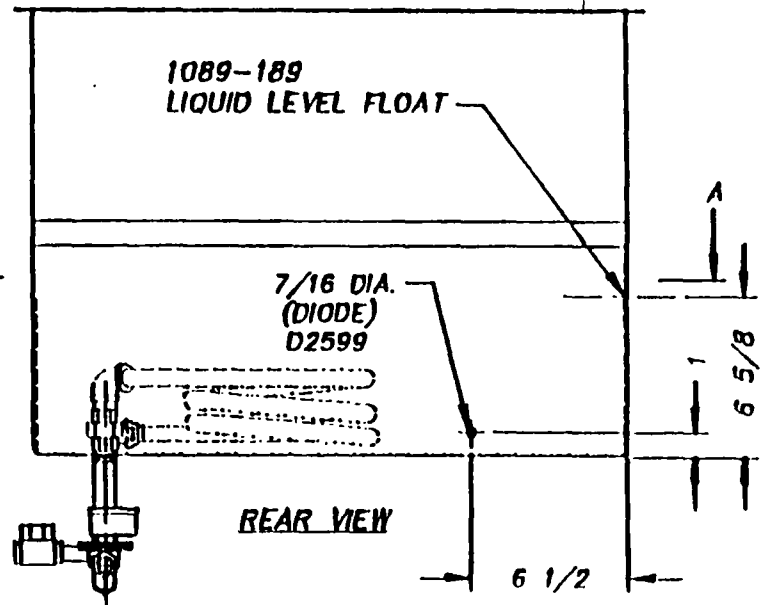

- △ ECN# 888 8.23.93
- △ ECN# 758 10.2.92
- △ ECN# 673 7.06.92

TOLERANCES	TITLE	NEXT ASSY	DWG. NO.
FRACTIONS ±1/64	STEAM COIL, DIODE AND LIQUID LEVEL FLOAT LOCATIONS	REQ.	1089-82
DECIMALS .XXX ± .005 .XX ± .01		SCALE 1:8	USED ON AS NOTED
ANGULAR ±1/2	MAT'L. AS NOTED		DRWN/DATE MAM 7.24.92
UNLESS OTHERWISE SPECIFIED	Insinger Machine Company Philadelphia, PA 19135 (215) 624-4800 FAX (215) 624-6966		

USED ON:

- 18-3
- 50-20N2-NSU (STRAIGHT)
- CS-4

IMMERSION HEATER*
DE13-XXX
(VOLTAGE AS SPECIFIED)

SECTION A - A

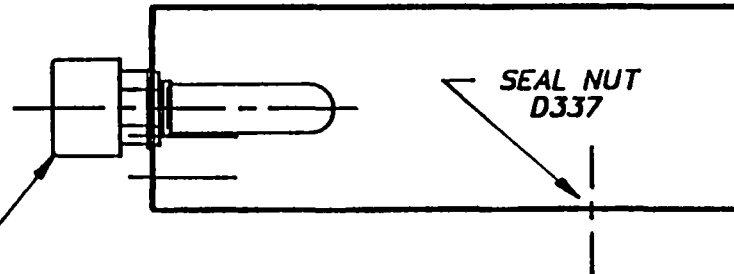

REAR VIEW

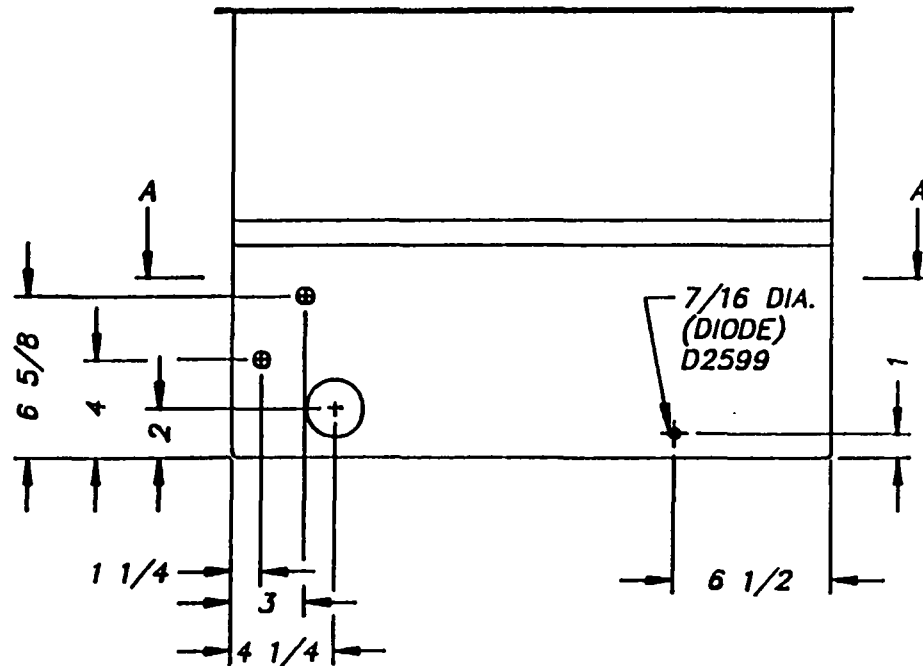
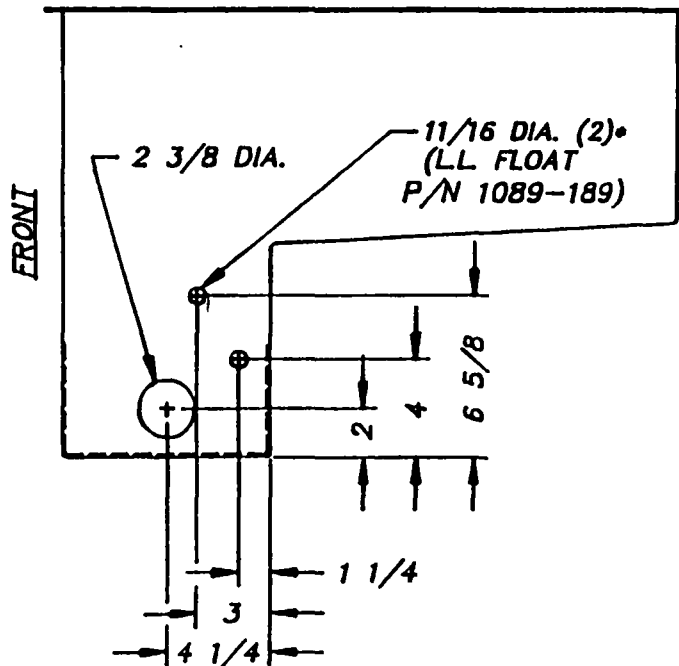

* HEATER & FLOAT SWITCHES ON REAR WALL FOR PRISON PACKAGES.

			TOLERANCES	TITLE	NEXT ASSY	DWG. NO.
			FRACTIONS ±1/64	ELECTRIC HTR., DIODE &	REQ'D -	1089-80
			DECIMALS	LIQUID LEVEL FLOAT LOCATIONS		
G	1082	10.25.94	.XXX ± .005	MATL	SCALE	USED ON
F	888	6.3.93	.XX ± .01	AS NOTED	1=8	SEE ABOVE
E	758	10.2.92	ANGLES ±1/2°			
REV	ECN NO	DATE	UNLESS OTHERWISE SPECIFIED	Insinger	Philadelphia, PA 19135	DRWN/DATE
FIL: PARTS\1089-80				Machine Company	(215) 624-4800	RFN
					FAX (215) 624-6966	1 29.92

Electric Htr, Diode & Liquid Level Float Locations

Fig. 8

Liquid Level Float Typical Installation

In order to insure the proper operation of your INSINGER dishwasher, it is necessary that the LIQUID LEVEL FLOAT be wiped free of any residue and/or moisture at each cleaning. This should be done, preferably, after each use of the machine, or, at a minimum, once each day.

The LIQUID LEVEL FLOAT is located below the scrap screens in those tanks which contain water heating devices (coils, steam injectors, or electric immersion heaters) and pump inlet strainers. They are usually located, in rackless and rack conveyor style machines, on the inside tank wall, at approximately water level, opposite and parallel to the inspection doors. In the door, stationary rack, type machines, the LIQUID LEVEL FLOAT may be found beneath the scrap screen.

Below is a depiction of the LIQUID LEVEL FLOAT and the surfaces which must be wiped clean.

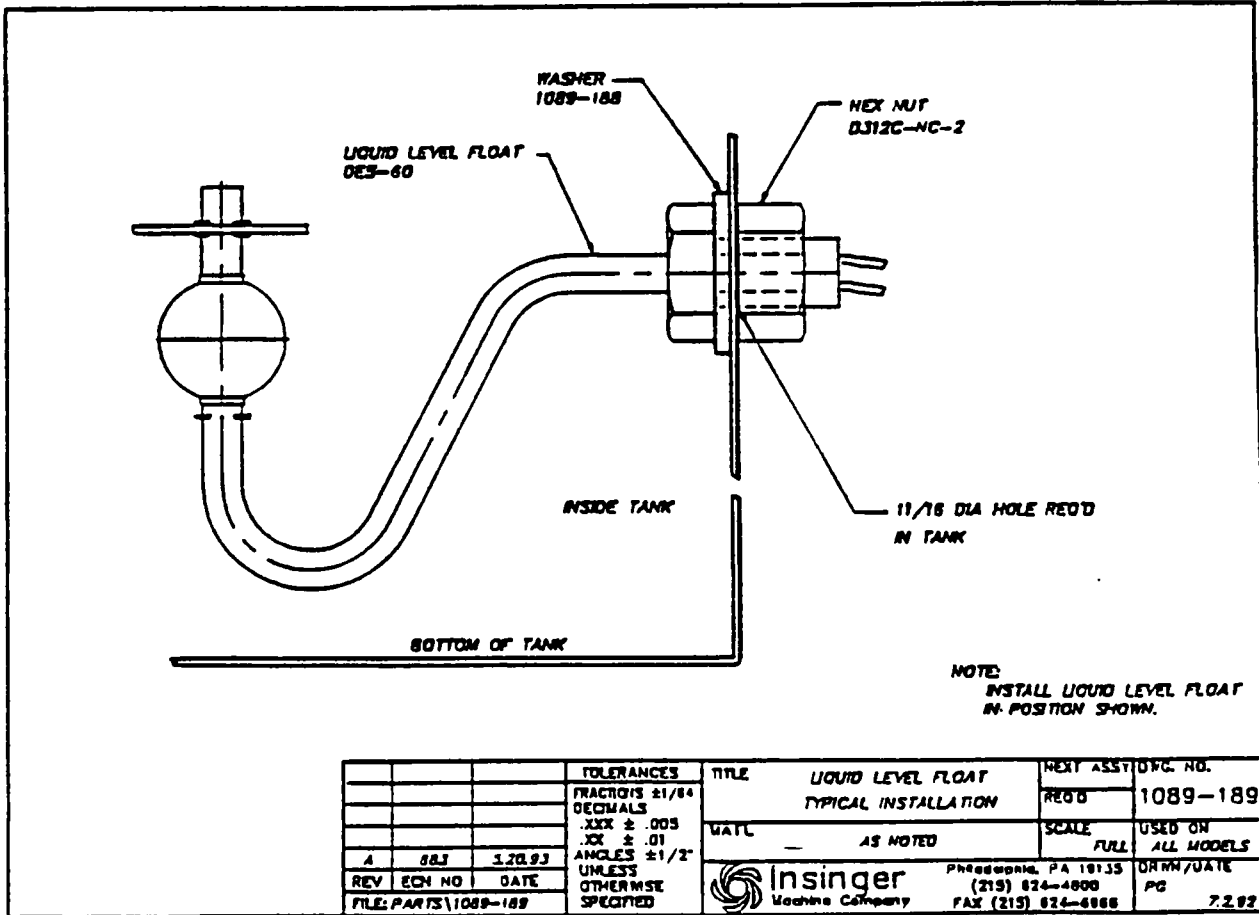

7-13

ITEM	PART NO.	DESCRIPTION	QTY.	ITEM	PART NO.	DESCRIPTION	QTY.	ITEM	PART NO.	DESCRIPTION	QTY.
1	D-2100	STEAM BOOSTER (1-2) (NOTE #1)	1	10	D2594	SOLENOID VALVE 1/2 IPS	1	18	D322F-E2-01	HEX. REDUCER 3/4 MIPS X 1/2 FIPS	1
2	SK-3355	BOOSTER STAND (NOTE #3)	1	11	D2483A	Y STRAINER 1/2 IPS	1	20	D314F-05-20	NIPPLE 1/2 IPS X 2 1/2 LG.	1
3	D314F-FC-00	CLOSE NIPPLE 1" IPS	1	12	D316A-E2-0J	90° ELBOW 3/4 MIPS X 1/2 C	1	21	D316F-01-02	90° STREET ELBOW 1/2 IPS	1
4	D316F-F2-F1	90° STREET ELL 1 MIPS X 1 FIPS	1	13	D2508A	PRESS. REG. & STRAINER 1/2 IPS	1	22	D2102A	STEAM TRAP 1/2 IPS	1
5	D316A-DJ-02	90° ELBOW 1/2 C X 1/2 MIPS	2	14	D314F-DC-00	CLOSE NIPPLE 1/2 IPS	3	23	D314F-05-48	NIPPLE 1/2 IPS X 6 LG.	1
6	D317A-DJ-F2	ADAPTER 1/2 C X 1 MIPS	1	15	D2J39	BALL VALVE 1/2 IPS	2	24	D320F-E1D101	TEE 3/4 FIPS X 1/2 FIPS X 1/2 FIPS	1
7	D207A-B4-17	COPPER TUBING 1/2 CTS X 4 1/4 LG.	2	16	D320F-F1D101	TEE 1" IPS X 1/2 IPS X 1/2 IPS	1	25	D2507	PRESSURE RELIEF VALVE 3/4 IPS	1
8	D316A-DJ-D3	90° ELBOW 1/2 C	1	17	D322F-02-C1	HEX. REDUCER 1/2 MIPS X 3/8 FIPS	1	26	-	-	-
9	D207A-B4-7	COPPER TUBING 1/2 CTS X 1 3/4 LG.	1	18	D2396	THERMOSTAT (SEE NOTE #2)	1	27	D318A-DJ-02	UNION, 1/2 C X 1/2 M	1

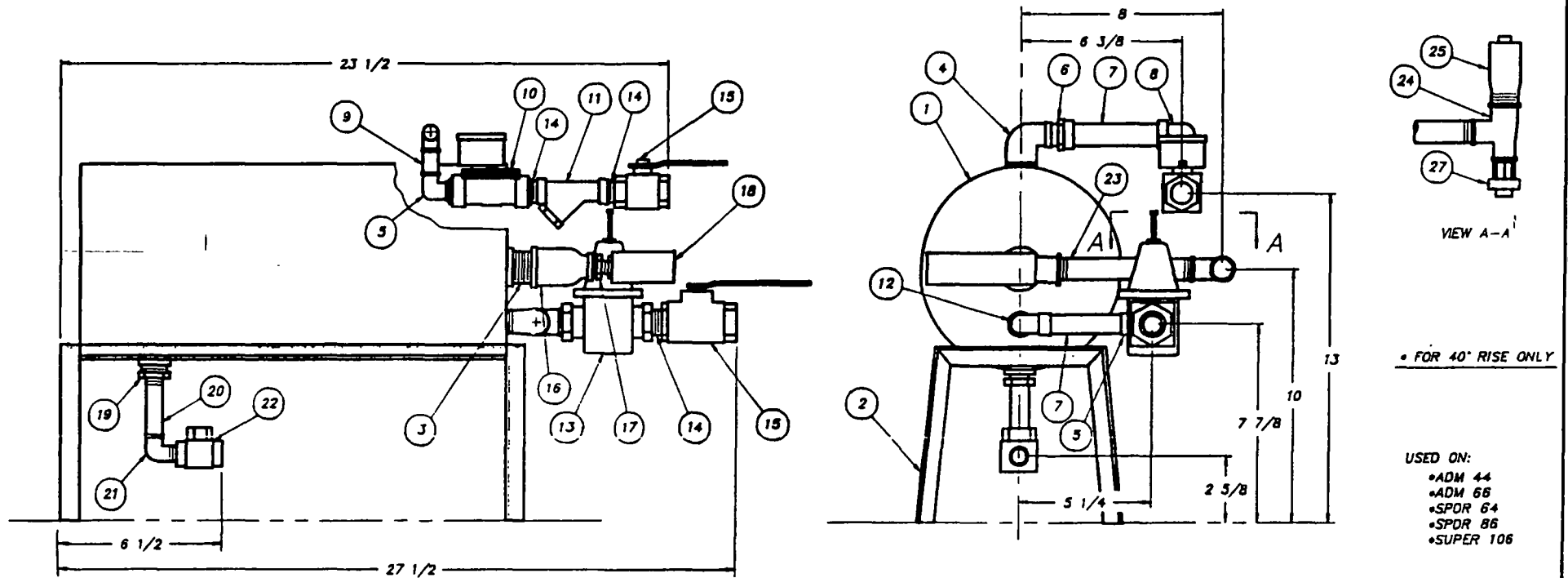

NOTES:
 1. (ITEM #1) ADD SUFFIX "NM" FOR NON-MAGNETIC MACHINES.
 2. (ITEM #18) USE PART NO. D-2396 AS STANDARD, AND PART NO. D-2301 WHEN LOW TEMP. CUT-OFF IS SPECIFIED.
 3. (ITEM # 2) USE PART NO. 975-129 FOR SHIPBOARD USE.

TOLERANCES			TITLE	NEXT ASSY	DWG. NO.
		FRACTIONS ±1/84	STEAM BOOSTER ASS'Y	REQ'D 1	1394-2
		DECIMALS	W/ POWER UNLOADER		
C	979	1.17.94	MATL	SCALE 1=4	USED ON AS NOTED
B	964	12.27.93	AS NOTED		
A	952	10.8.93			
REV	ECN NO	DATE	Insingher Philadelphia, PA 19135 Machine Company (215) 824-4800 FAX (215) 824-8868		
FILE: PARTS\1394-2			DRWN/DATE PG 79.93		

Fig. 10 Steam Booster Assembly

Fig. 11 Electric Booster Assembly

NO.	DESCRIPTION	PART NO.	QTY
1	BOOSTER ASSEMBLY	C9-12	1
2	RELIEF VALVE	SUPL. W/BOOSTER	1
3	BALL VALVE 1/2 IPS	D-2339	1
4	CLOSE NIPPLE 1/2 IPS	D314A-DCL	2
5	BRACKET	982-49	1
6	PRESS. REG. & STRAINER 1/2 IPS	D-2508A	1
7	TEE 1/2 IPS	D320A-D1	1
8	REDUCER 1/2 MIP S = 1/4 FIP S	D322A-D2-B1	1
9	PIPE PLUG 1/4 IPS	D328A-B-A	1
10	ADAPTER 1/2 MIP S = 1/2 C	D317A-D2-D3	1
11	COPPER TUBING 1/2 CTS = 6 1/2 LG.	D207A-B4-26	1
12	90° ELBOW 1/2 C	D316A-D3	1
13	COPPER TUBING 1/2 CTS = 7 1/4 LG.	D207A-B4-30	1
14	90° ELBOW 3/4 FIP S = 1/2 C	D316A-E1-D3	1
15	90° STREET ELL 1/2 IPS	D316A-D1-D2	1
16	UNION 1/2 C	D318A-D3	1
17	COPPER TUBING 1/2 CTS = 22 1/2 LG	D207A-B4-90	1
18	COPPER TUBING 1/2 CTS = 40 1/2 LG	D207A-B4-163	1
19	COPPER TUBING 1/2 CTS = 3' LG.	D207A-B4-12	1
20	90° ELL 1/2 MIP S = 1/2 C	D316A-D2-D1	1
21	COPPER TUBING 1/2 CTS = 6 1/2 LG	D207A-B4-27	1
22	90° ELL 1/2 C	D316A-D3	2
23	90° STREET ELL 3/4 FIP S = 1/2 MIP S	D316A-E1-D2	1
24	90° ELL 1/2 FIP S = 1/2 C	D316A-D1-D3	1

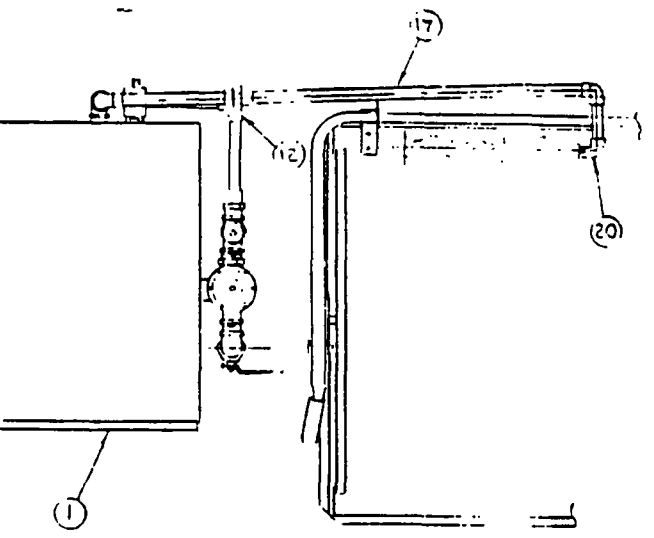

USED ON:
10-3, 1A-3C,
50-20N2-NSU

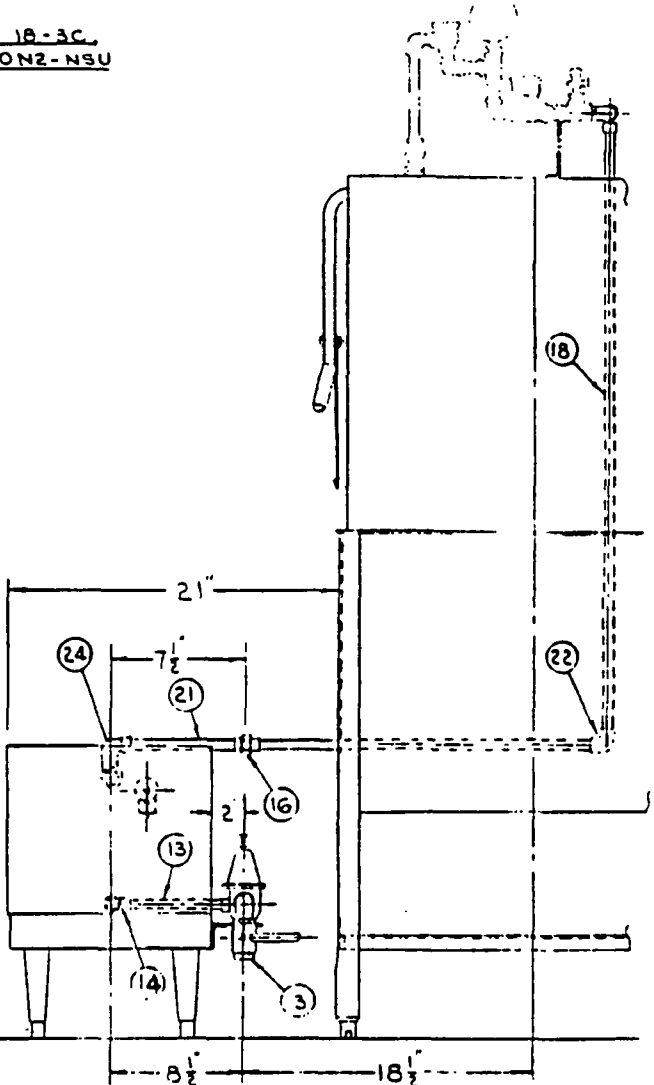
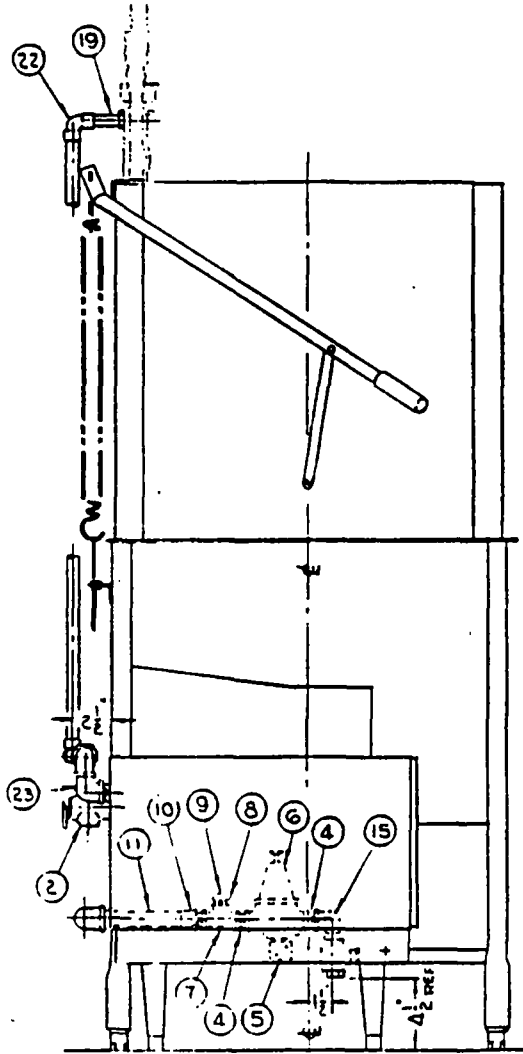

SUPERSEDES DWGS. 1089-119
DATED 10-23-85, 1089-157 DATED
3-5-87, 1089-28 DATED 3-4-87

7-14

TOLERANCES	TITLE	PATT NO	OWG NO
FRACTIONS ± 1/64	ELECT. BOOSTER ASSEMBLY	REG 1	1089-87
DECIMAL ± .005		SCALE 1"	USED ON 11110
ANGULAR ± 1/2°	MATL NOTED		
UNLESS OTHERWISE SPECIFIED	INSINGER MACHINE CO. PHILA. PA. 19135 (215) 624-4800		P 3-23-88

1089-87

7-14

7.2 RECOMMENDED PROVISIONING

NEW

MODEL 50-20-N2-NSU**

DESIGNED TO PASS THROUGH 26" x 66" WATER TIGHT HATCH

***For non-magnetic mine sweepers add NM.*

Part No.	Qty.	Name of Part
D2-541	1	Suction strainer
1084-76	1	Spray hub wash
952-27	1	Bushing
D2-554-2	2	Plug 3/4-10 UNC-2A
952-28-A	1	Locking screw
372-52	1	Spray hub rinse
D-2286	2	Spray nozzles—final rinse
D-2021	2	Spray nozzles—final rinse
D-2397	1	Solenoid valve
D-2495	1	Temp. gauge—final rinse
D-2519	1	Temperature gauge
D-924	1	Water level indicator
SK-2294-A	1	Spring
D-2215A	1	Microswitch
D-1003	1	Pressure gauge—discharge
D-2261	1	Pressure gauge—final rinse
1084-200	3	Pump repair kit
951-101	1	Overflow repair kit
DE-1-10	1	Magnetic contactor
DE-5-9	1	Pushbutton
D-436	1	Water pump impeller
D-2267A	1	Steam thermostat
DE-7-11	1	Timer (wash)
DE-7-12	1	Timer (rinse)

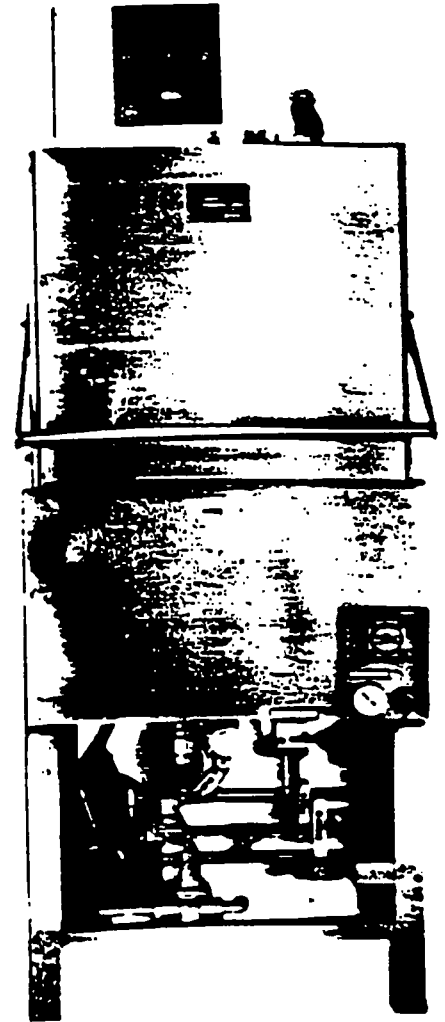

LOOK FOR THIS LABEL



• When ordering parts, be sure to include the **MODEL NUMBER** and **SERIAL NUMBER**.

7.3

STANDARD PARTS LIST

<u>PART NAME</u>	<u>INSINGER PART NO.</u>	<u>MANUFACTURER</u>	<u>MFG. PART NO.</u>
TIMER	DE7-27	SSAC BALDWINVILLE, NY	ORMZ4A23
TRANSFORMER	DE6-6 DE6-14	ACME LUMBERTON, NC	TA1-81323 TA1-81143
TERMINAL BLOCK ASSEMBLY	DE3-26	BUCHANON UNION, NJ	515, 530
TERMINAL MARKER	DE3-34	CINCH JONES ELKGROVE, IL	MS12-141
TERMINAL BLOCK	DE3-33	CINCH JONES ELKGROVE, IL	12-141
CONTACTOR	DE1-54	AEG HAWTHORNE, NY	SP-7-0-G
PILOT LIGHT (RED)	DE9-44	INDUSTRIAL DEVICE, INC. EDGEWATER, NJ	1090A1
PILOT LIGHT (WHITE)	DE9-45	INDUSTRIAL DEVICE, INC. EDGEWATER, NJ	1090A4
PILOT LIGHT (AMBER)	DE9-46	INDUSTRIAL DEVICE, INC. EDGEWATER, NJ	1090A3
BULLET FOOT	D2430	KLEIN ALLENWOOD, NJ	222-SS-2H
VACUUM BREAKER	D-2241A	CONBRACO MATTHEWS, NC	38-103-01
"Y" STRAINER	D-2483A	CONBRACO MATTHEWS, NC	59-003-01

7-16

STANDARD PARTS LIST (CONT'D)

<u>PART NAME</u>	<u>INSINGER PART NO.</u>	<u>MANUFACTURER</u>	<u>MFG. PART NO.</u>
SEAL ASSEMBLY (E8)	D2-534	GRATNGER PHILADELPHIA, PA	1R312
"V" SEAL (DRAIN)	D2-557	STAUER MALVERN, PA	8506-01-87-N-4180
"O" RING (DRAIN)	D2-548 D2-549 D2-550	GALLAGHER KING OF PRUSSIA, PA	01-241 01-226 01-326
OVERLOAD (SEE CONTROL BOX LAYOUT SK-2833 FOR PARTIC- ULAR APPLICATIONS)	DE2-29 DE2-30 DE2-33 DE2-40	AEG HAWTHORNE, NY	B17-2HS B17-2IS B17-2LS B17-2NS

7-17/(7-18 blank)

CHAPTER 8

INSTALLATION

8.1 GENERAL

8.1.1 The purpose of this chapter is to furnish the data required to place and connect the Insinger 50-20N2(C)-NSU dishwasher system.

8.1.2 The components that make up this system are shipped together, assembled, in one container. They must be disassembled, then reassembled prior to operation. Refer to Table 2 (page 1-3) for list of equipment supplied.

8.1.3 Appropriate electrical power, steam and drainage must be supplied. See Table 1 (page 1-2) for this information.

8.2 PLACEMENT

8.2.1 Uncrate machine carefully. Take care not to damage accessories which may be mounted onto the machine. As components are removed from the shipping container, check to be sure that all items have been included. Visually inspect for damage, such as punctured hoses, cracked housings, bent parts, etc.

8.2.2 Refer to Tables 1 and 2 for overall dimensions, weight of the various components and other requirements.

8.2.3 The optimum placement of the components in relation to each other is as pictured in Figure 3 (page 7-2). Be sure sufficient level space exists for placement of the machine and that suitable drainage is available nearby.

NOTE

If the machine is installed in a high humidity area, an overhead exhaust system will reduce drying time.

8.2.4 FINAL INSTALLATION

8.2.4.1 The following services must be made available and "roughly" located prior to the positioning of the machine:

- a. 1/2 NPT hot water (140 °F) to final rinse booster
- b. 1/2 NPT steam (10 psig MIN) to booster, if applicable
- c. 1/2 NPT steam (10 psig MIN) to Wash tank, if applicable
- d. 3/8 NPT condensate return for booster, if applicable
- e. 3/8 NPT condensate return for wash tank, if applicable
- f. 1 1/2 NPT drain
- g. electrical connections, 440 volt, 3 phase, 60 hz

8.2.4.2 Position the machine and level. Bolt to the deck using four 1/2" bolts. Position electric booster heat exchanger, if applicable, and bolt to deck using four 3/8" bolts.

8.2.4.3 Connect steam condensate returns (on steam-heated machines only), water, and drains to dishwasher.

8.2.5 ELECTRICAL CONNECTIONS. All electrical power shall be in accordance with the current, voltage, and phase specified in this manual, on the electrical data plate, and on the control box label.

CAUTION

The pump must never be run for a period greater than 30 seconds without water in the tank.

Inspect motor. Motor must rotate in the direction indicated by the arrow cast into the pump housing. Additional connections may be required for electrically operated automatic controls. In all cases, connect to circuit breaker panel or fused disconnect switch (furnished by user) as required. Wiring diagram is located inside control box.

8.2.6 MECHANICAL OPERATIONS. Water and, if applicable, steam supply lines must be sized according to specifications and installation layout in Figure 3 (page 7-2). Piping of a greater capacity may be used. There must be no downsizing of any manufacturer supplied fitting; otherwise, specified flow rates will not be achieved. Flush all lines prior to connection in order to remove any debris. Failure to do so may result in clogged valves. If applicable, saturated steam shall be supplied within the pressure range of 10 to 35 PSIG.

8.2.7 Pressure on the final rinse water connection should be 20 PSIG (measured by pressure gauge with line open). Connect drain line to pipe size not less than manufacturer's supplied fitting size. Drain line should be properly vented and should have fall of not less than 1/4" per foot.

8.2.8 The dishwasher is now ready for operation after suitable tables and accessory equipment (detergent dispenser, rinse injector, etc.) are installed.

8.3 INSTALLATION VERIFICATION

8.3.1 After 50-20N2(C)-NSU dishwasher components have been installed and hooked up to electrical and steam supplies, check all connections and piping to ensure that they are secure and that there are no cracks and punctures throughout the system.

8.3.2 Run the system through one washing operation in order to purge the lines and test the system. Refer to Chapter 2, Operation, for instructions on how to proceed.

CHAPTER 9

ELECTRICAL INFORMATION

9.1 GENERAL

9.1.1 The following pages contain all information necessary to provide proper electrical hook-ups for this machine, and schematics to aid in troubleshooting an electrical malfunction.

WARNING

Electrical equipment must be turned off before servicing.

CAUTION

Never bend the booster heating elements (Figure 12). If bending is necessary, check with the factory.

Do not supply current to the booster heater (Figure 12) until the tank has been filled and all air has been vented through the dishwasher rinse nozzles. The heating elements will burn out in seconds if they are not covered with water.

9.2 ELECTRICAL IMMERSION HEATERS

9.2.1 General Information. Immersion heaters with 115/120 volt or 230/240 volt elements can be connected in series for higher voltage operation except where wattage is supplied on the respective elements.

9.2.2 Instructions for Installation and Maintenance.

NOTE

Never bend the booster heating elements (Figure 12). If bending is necessary, check with the factory.

Care must be taken to ensure complete immersion of the heated length of the heater at all times. The heated surface should never be in contact with any sludge.

9.2.2.1 In the case of flange and pipe-thread type heaters, where a gasket seal is necessary, the gasket surface should be clean and dry before the heater is seated. The terminals must be protected at all times from moisture or vapor. In hazardous locations, explosion-resistant covers should be used.

9.2.2.2 The heaters should be inspected periodically for coatings and corrosion, and cleaned if necessary.

9.3 INSTALLATION INSTRUCTIONS FOR HATCO ELECTRIC BOOSTER WATER HEATERS

9.3.1 GENERAL INSTRUCTIONS. Hatco Electric Booster water heaters are available for operation on almost all common ac power systems. Check the nameplate for the specified electrical service. All connections to heating elements, thermostats, and magnetic contactors have been made at the factory.

CAUTION

Do not supply current to the booster heater until the tank has been filled and all air has been vented through the dishwasher rinse nozzles. The heating elements will burn out in seconds if they are not covered with water.

9.3.2 INSTALLATION. Remove two screws under bottom edge of lip beneath the front cover. Pull bottom of cover forward and down. Bring the power leads from a properly sized fuse disconnect switch or circuit breaker through the knockout provided in the base and connect to the terminal block. Replace the front cover.

Fig. 12

Wiring, Steam Booster

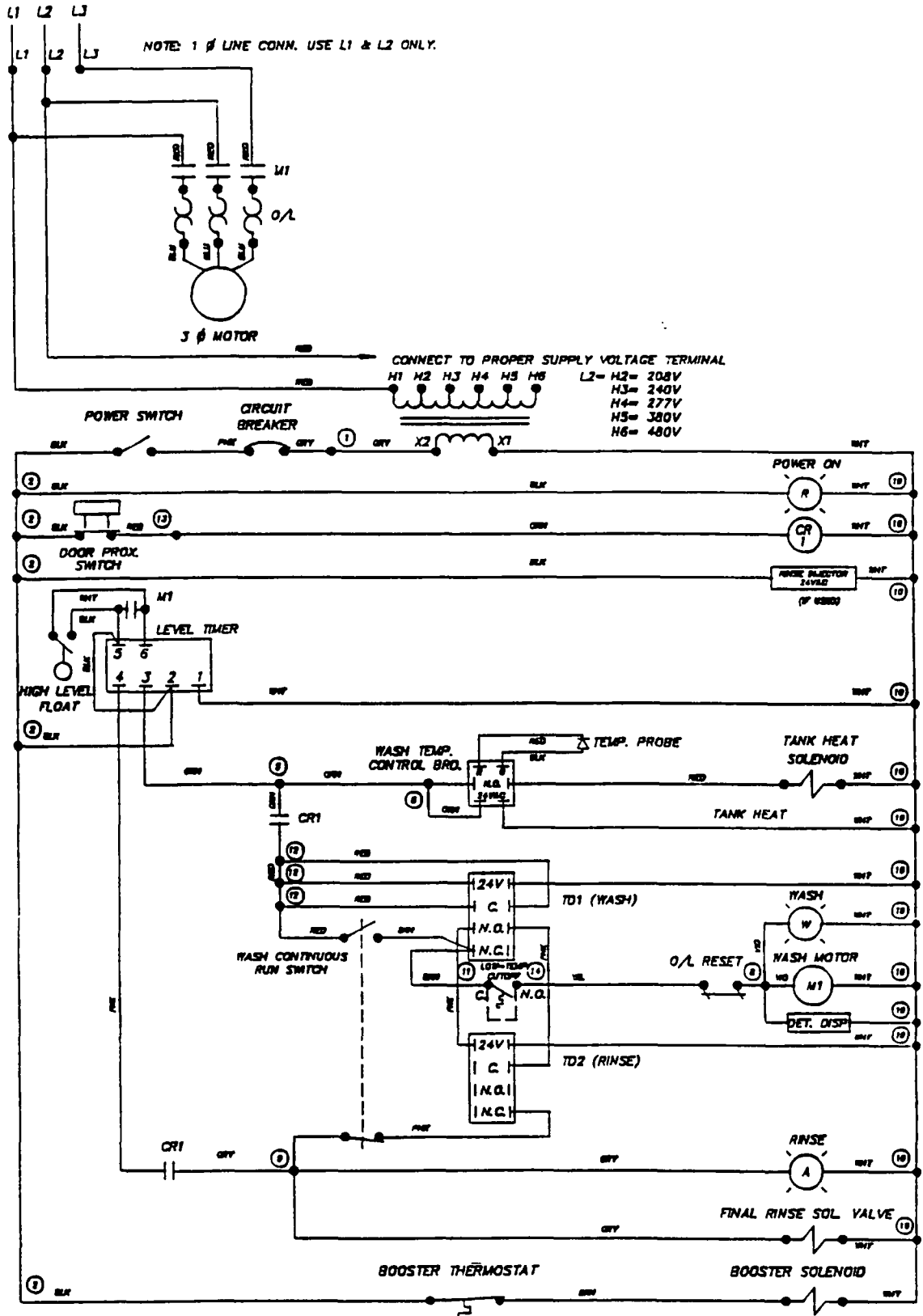

NOTE:
1. IF NO LOW-TEMPERATURE CUTOFF IS SPECIFIED,
A JUMPER IS PROVIDED BETWEEN TERMINALS 11 & 14.

FILE \HW\000R010

△ ECH# 892 6.14.83
 △ ECH# 837 3.25.83
 △ ECH# 802 1.15.83

		6245 State Rd. Tel. 215-624-4800 Philadelphia FAX: 215-624-4966 PA 19133-2996	
MACHINE: DOOR TYPE MACHINE - STEAM		DWG. NO.	
DRAWN: RAF 08.05.88		WDOOR010 G	
APPROVED: MJM 08.05.88			

Fig. 12A

Wiring, Electric Booster

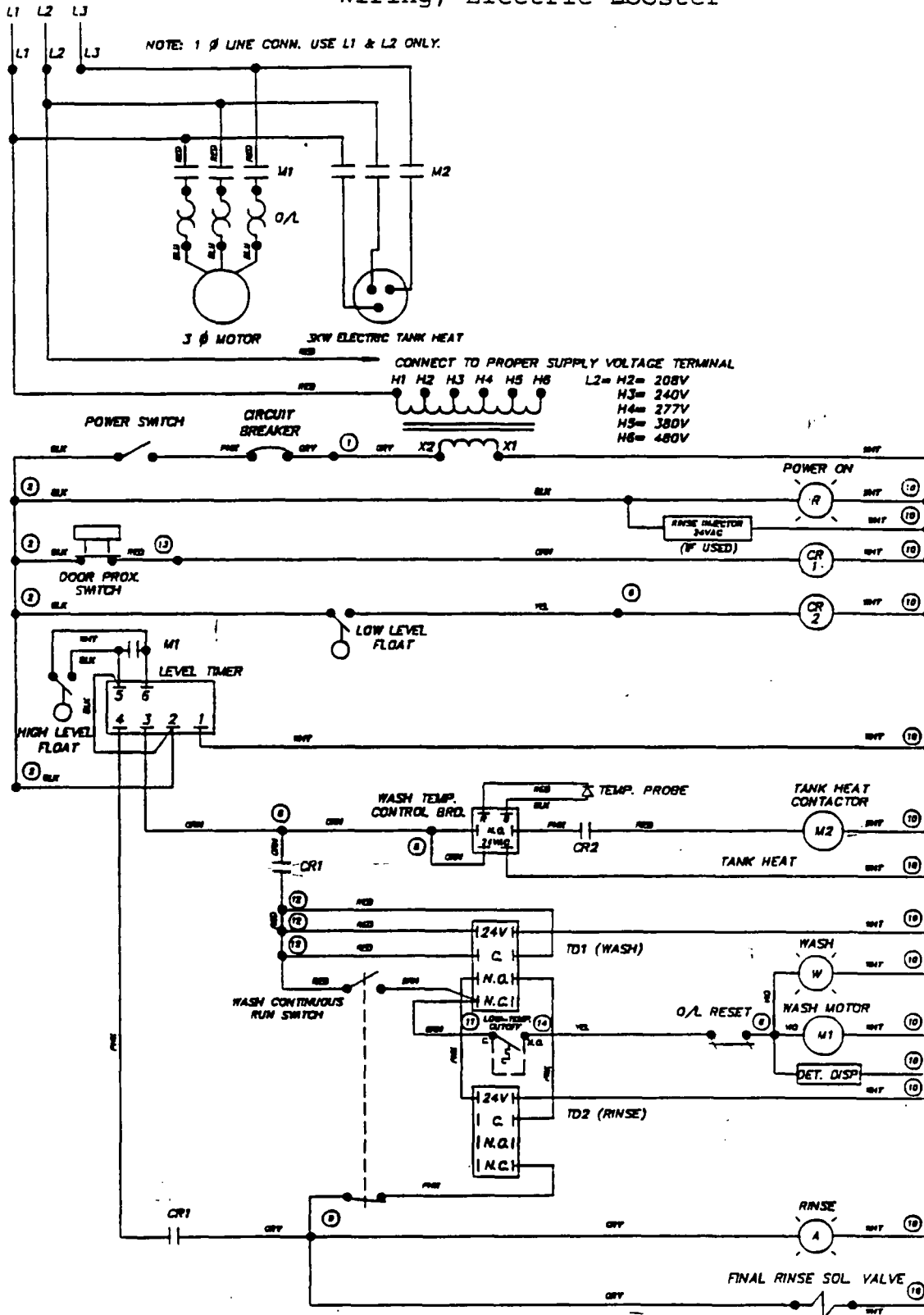

NOTE:

1. IF NO LOW-TEMPERATURE CUTOFF IS SPECIFIED, A JUMPER IS PROVIDED BETWEEN TERMINALS 11 & 14.

- △ ECH# 892 6.14.83
- △ ECH# 857 3.23.83
- △ ECH# 802 1.15.83
- △ ECH# 758 11.3.82

FILE: \WRE\DOOR020

	INSINGER MACHINE COMPANY	6245 State Rd. Tel. 215-624-4800 Philadelphia PA 19135-2998 FAX: 215-624-6966
	MACHINE: DOOR TYPE MACHINE - ELECTRIC DWG. NO.	
DRAWN: RAF 08.05.88		WDOOR020 E
APPROVED: MJM 08.05.88		

PARTS LIST-CONTROL BOX COMPONENTS
COMMANDER 18-3, CS-4

9-5

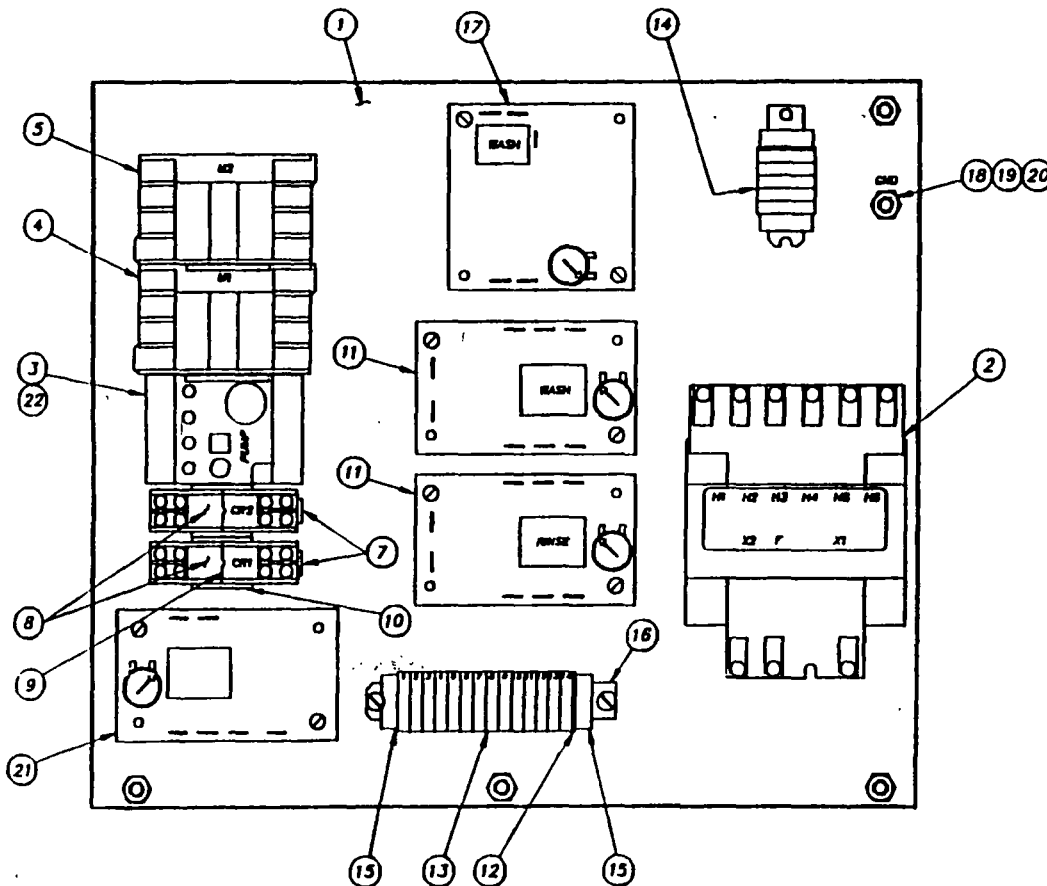

ITEM	DESCRIPTION	PART NO.	QTY.
1	CONTROL COMPONENT PLATE	DE10-6	1
2	TRANSFORMER		1
	ALL VOLTAGES	DE6-6	
3	OVERLOAD		1
	480V-3PH-60HZ 1.8A	DE2-52	
	380V-3PH-50HZ 2.0A	DE2-52	
	240V-3PH-60HZ 3.6A	DE2-53	
	240V-1PH-60HZ 8.0A	DE2-56	
	220V-3PH-50HZ 4.3A	DE2-54	
	220V-1PH-50HZ 9.0A	DE2-57	
	208V-3PH-60HZ 3.8A	DE2-53	
	208V-1PH-60HZ 10.0A	DE2-57	
4	CONTACTOR (PUMP MOTORS)	DE1-66	1
5	CONTACTOR (ELEC. TANK HEAT ONLY)	DE1-66	1
6			
7	RELAY BASE	DE2-37	AR
8	RELAY	DE2-38	AR
9	RELAY HOLD-DOWN SPRING	DE3-43	AR
10	DIN RAIL	DE9-84A	1
11	TIME DELAY (WASH, RINSE)	DE7-27	2
12	TERMINAL END COVER PLATE	DE3-40	1
13	TERMINAL SECTION	DE3-39	14
14	TERMINAL BLOCK ASS'Y.		
	(UP TO 300V.)	DE3-9	1
	(300V. - 600V.)	DE3-3	1
15	TERMINAL END CLAMP	DE3-41	2
16	DIN RAIL (TERMINAL STRIP)	DE3-42B	1
17	CIRCUIT BOARD (TEMPERATURE CONTROL)	DE9-96	1
18	1/4 INTERNAL TOOTH LOCK WASHER	D313C-G5	1
19	1/4-20 HEX NUT	D312C-GC2	1
20	1/4-20 X 1/2 LG. WELD STUD	D309C-GC-4G	1
21	TIMER, LEVEL	DE7-31	1
22	OVERLOAD BASE	DE2-60	1

USED ON: COMMANDER 18-3
COMMANDER 18-4
CS-4

Fig. 13 Control Panel

PARTS LIST-CONTROL BOX COMPONENTS
COMMANDER 18-3, CS-4

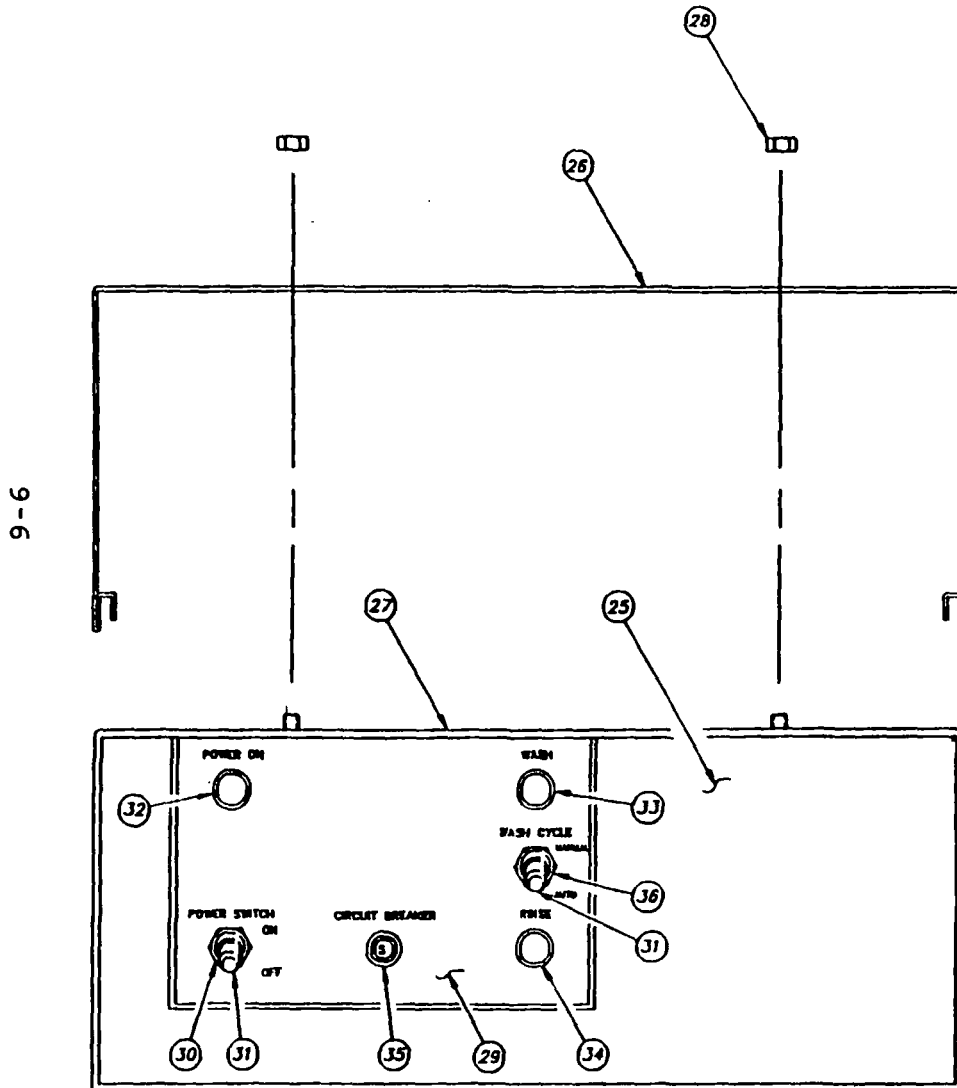

ITEM	DESCRIPTION	PART NO.	QTY.
25	CONTROL BOX	D3-704	1
26	CONTROL BOX COVER	D3-713	1
27	GASKET	9007-001	1
28	SEAL NUT	D312C-EF-5	4
29	LEGEND DECAL	SK-2306	1
30	SWITCH	DE5-8	1
31	BOOT, SWITCH	DE9-13	2
32	PILOT LIGHT (RED)	DE9-107	1
33	PILOT LIGHT (WHITE)	DE9-108	1
34	PILOT LIGHT (AMBER)	DE9-109	1
35	CIRCUIT BREAKER (5A)	DE9-43	1
36	SWITCH	DE5-11	1

NOT SHOWN:

TANK IMMERSION HEATER (3KW)		
480VAC-3PH	DE13-SC73	1
380VAC-3PH	DE13-SC53	
240VAC-3PH	DE13-SC43	
240VAC-1PH	DE13-SC41	
220VAC-3PH	DE13-SC33	
220VAC-1PH	DE13-SC31	
208VAC-3PH	DE13-SC23	
208VAC-1PH	DE13-SC21	

Fig. 14 Electric Booster Wiring

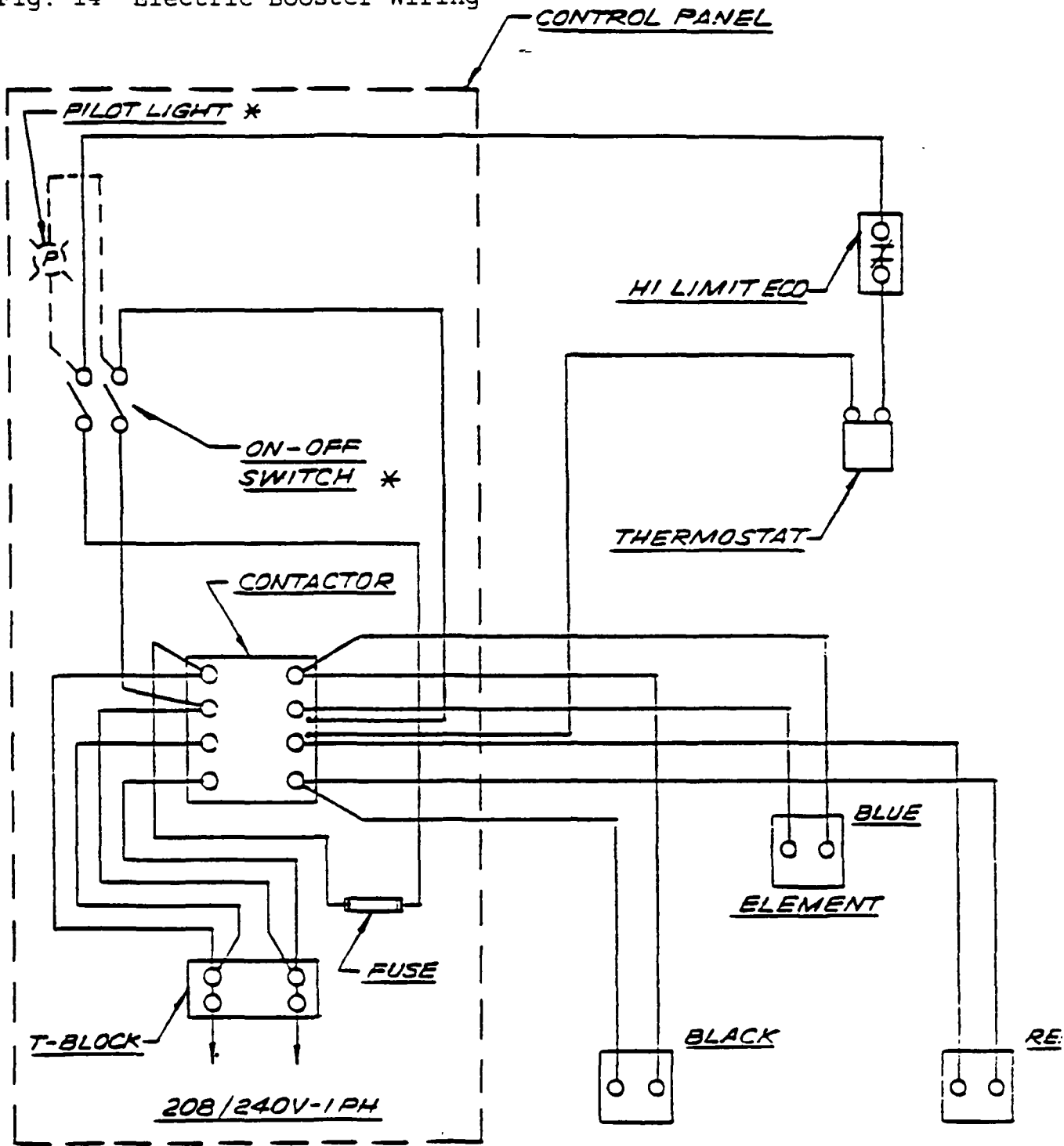

* CIRCUIT FOR LIGHT AND SWITCH WHEN SUPPLIED.

WIRING DIAGRAM
FOR
SMALL COMPACT BOOSTER
10.5 KW - 208/240V - 1 PH

314
INSINGER MACHINE CO.
PHILA., PA. 19135 (215) 624-4800

RAE 1.30.87

LIBERTY™ WAREWASHING SYSTEMS

&

COMPLETE WAREWASHING SYSTEMS

INSTALLATION • OPERATION • MAINTENANCE

EFFECTIVE DATE: 12/1/94

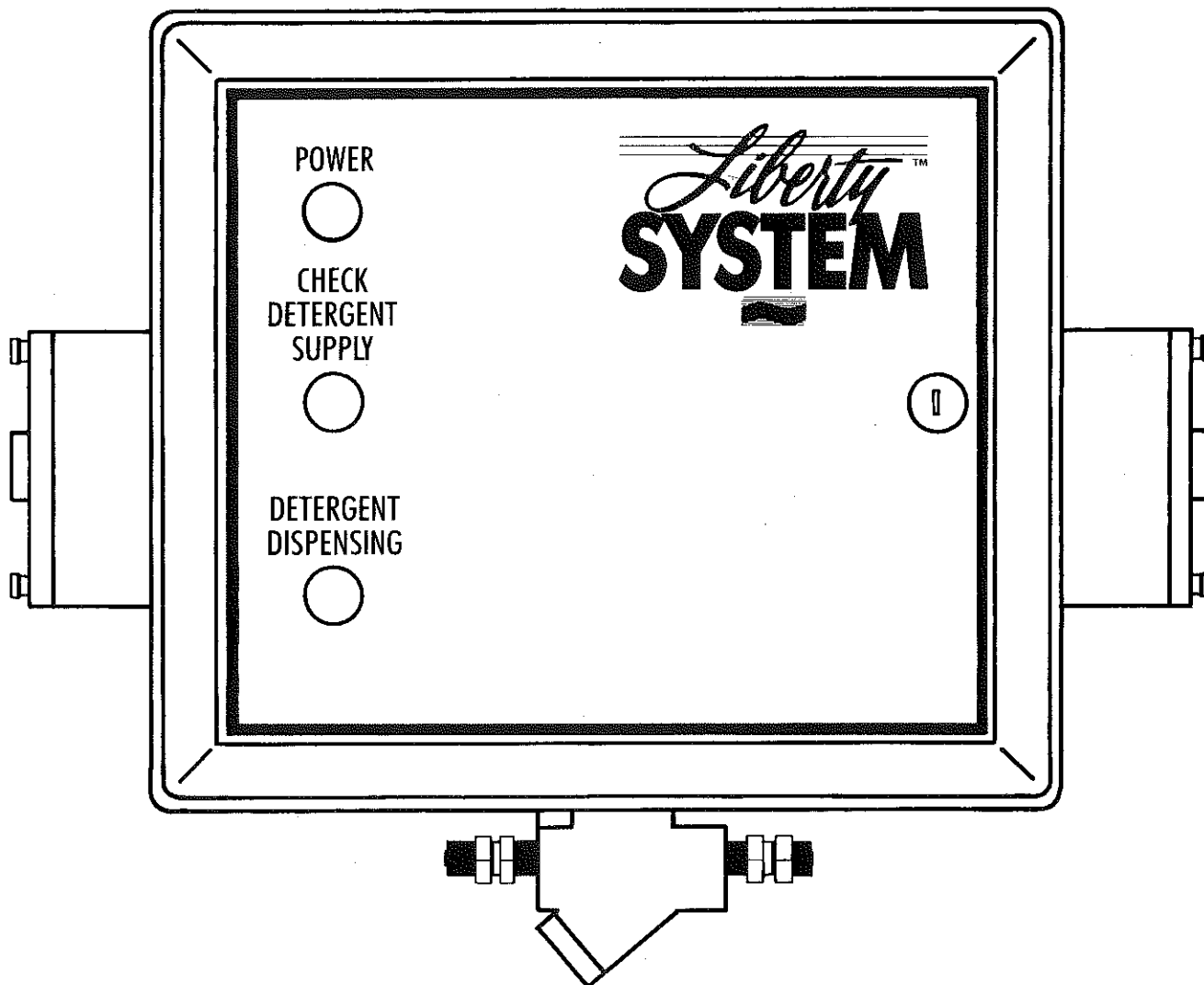

NOTICE

EFFECTIVE IMMEDIATELY, ALL SYSTEMS WILL SHIP WITH THE BUTTON PROBE. WE HAVE FOUND THIS PROBE TO WORK BETTER WITH MOST NORMAL WATER CONDITIONS. THE OLD STYLE PROBE WILL BE AVAILABLE BY SPECIAL ORDER.

INTRODUCTION

The LIBERTY™ line models are compact, easy to install and offer a choice of systems to accurately measure powder detergent, liquid rinse-aid, liquid sanitizer and/or destainer into conventional type dishmachines, using a combination of a powder detergent dispenser, dependable high pressure peristaltic pumps and sophisticated digital electronic technology.

Model F2

Features the Freedom Powder detergent dispenser and a peristaltic Rinse pump. This system can be used on any high temperature dishmachine. (Page 4)

Model R2

Features the 901 (1 Gallon) reservoir and a peristaltic Rinse pump. This system can also be used on any high temperature dishmachine. (Page 5)

Models F3 and R3

Features the addition of a peristaltic Sanitizer pump enabling its use on Low-Temperature dishmachines that are not of the fill-

and-dump type. Applicable machines include: HOBART AM ES-11 and AM ES-12, HOBART 14C and JACKSON model 100L, etc.

Models FD3 and RD3

Features the addition of a High pressure peristaltic pump for Destaining applications during the dishmachine wash cycle.

Complete Warewash 2 and System 3

The complete Warewashing Systems provide a reliable means of dispensing liquid detergent and rinse-aid via the two high pressure peristaltic pumps.

System 2 contains both detergent and rinse pumps and can be used on any high temperature dishmachine.

System 3 features the addition of a Sanitizer pump, enabling its use on Low-Temperature dishmachines that are not of the fill and dump type. Applicable machines include: HOBART AM ES-11 and AM ES-12, HOBART 14C and JACKSON Model 100L, etc.

SYSTEM CHECK LIST

Control Panel / Complete with:

ITEM	SKU NO.
1 Control Board	E2-0211-14
1 Display Board	E2-0212-14
1 ¼" 24v. AC Solenoid Valve (Liberty System only)	E2-0052-04
1 Rinse Squeeze Tube	E2-0431-04
1 Sanitizer or Destainer Squeeze Tube (Liberty and Warewash 3 Systems only)	E2-0394-04
1 Detergent Squeeze Tube (Warewashing Systems only)	E2-0394-04
1 Hosebarb (Sanitizer Pump)	E2-0428-02
2 Hosebarbs (Detergent or Destainer Pumps)	E2-0428-02
1 1 oz. Tube Silicone Grease	E2-0012-12

INSTALLATION ACCESSORIES

20' 2 Conductor wire	E2-B004-01
15' ¾" Impolene Tubing (Rinse)	E2-A044-02
10' ¼" Copper Tubing (Liberty Systems only)	E2-B031-02
15' ¼" Polyflow Tubing (Sanitizer)	E2-C041-02
15' ¾" od Flexible PVC Tubing (Detergent or Destainer)	E2-B336-02
1 { ¾" poly x ⅛" npt Brass Straight (Rinse) For use with Warewash 2, Liberty F2 and R2 Systems only. }	E2-0208-02
1 { ¾" poly x ⅛" npt Stainless Steel Straight (Rinse) and ¼" poly x ⅛" npt Straight (Sanitizer) For use with Liberty FD3, RD3 and Warewash 3 Systems only }	E2-0432-02 E2-0340-02
1 { ¾" poly x ½" plastic fitting (Detergent or Destainer) For use with Liberty FD3, RD3 and Warewashing Systems only }	E2-0430-02
1 Probe Kit	E2-0039-05
1 Low-Temp Conversion Sticker (Liberty F3, R3 and Warewash 3)	E2-0264-09
1 Warewash 3 Installation Kit	E2-B035-05
1 Warewash 2 Installation Kit	E2-B036-05
1 Liberty™ F2 Installation Kit	E2-0045-05
1 Liberty™ F3 Installation Kit	E2-0046-05
1 Liberty™ R2 Installation Kit	E2-0047-05
1 Liberty™ R3 Installation Kit	E2-0048-05
1 5 Gallon Standpipe (Rinse)	E2-0002-13
1 5 Gallon Standpipe (Sanitizer or Destainer)	E2-0007-13
1 5 Gallon Standpipe (Detergent)	E2-0007-13

OTHER STANDPIPES AVAILABLE

1 Gallon Standpipe (Rinse)	E2-0001-13
1 Gallon Standpipe (Detergent, Sanitizer or Destainer)	E2-0006-13
15 Gallon Standpipe (Rinse)	E2-0003-13
15 Gallon Standpipe (Detergent, Sanitizer or Destainer)	E2-0008-13
1 Set of Standpipe Identification Tags	E2-0164-09
Detergent Standpipe Identification Tag	E2-A164-09
Rinse Standpipe Identification Tag	E2-B164-09
Sanitizer Standpipe Identification Tag	E2-C164-09

INSTALLATION

E: Do not mount the control panel in direct path of excessive steam, vapor, heat, or where it could be accidentally damaged. WHEN OPENING CABINET - DO NOT USE EXCESSIVE PRESSURE ON DOOR

Survey the dishmachine and its functional environment to determine LIBERTY™ equipment mounting locations, wire/conduit routing, plumbing requirements, service accessibility and non-interference with normal dishmachine operation prior to making installation.

1. Install the control panel with the wall mount hardware provided.
2. Product standpipes are supplied with six feet of vinyl tubing. This is the maximum length of suction tubing recommended. (Greater lifts will reduce injection capacities)
3. Use teflon tape or pipe dope and install the $\frac{3}{16}$ " x $\frac{1}{8}$ " npt injection fitting into the dishmachines Rinse line. Connect the $\frac{3}{16}$ " Impolene discharge tubing into the injection fitting and insert it about 3" into the water line as in FIGURE 2.

Use the $\frac{1}{4}$ " poly x $\frac{1}{8}$ " nylon injection fitting for the optional Sanitizer pump. Insert the $\frac{1}{4}$ " polyflow discharge tubing thru the injection fitting downstream into the water line.

The optional Sanitizer injection fitting should be located downstream from the Rinse injection fitting. See FIGURE 1.

Most machines will have holes already tapped into the Rinse line for these purposes. If no holes are present, select a spot on the Rinse line downstream from the Vacuum Breaker. (Most codes require installation at least 6" below the discharge side of an approved Vacuum Breaker) Drill an $1\frac{1}{32}$ " hole in the Rinse line and tap to $\frac{1}{8}$ " npt.

MOUNTING THE DISHACHINE PROBE

1. Insure the dishmachine recirculating wash tank is empty of water.
2. Examine the tank for any pre-punched holes made by the manufacturer or a previous chemical supplier. If it is in a good location (appx. 2-3" above the bottom of the tank and not near a corner or obstruction such as the tank heater) go ahead and use it. If there is no hole present, or it's in a poor location, a $\frac{3}{8}$ " hole must be drilled and enlarged to $\frac{7}{8}$ " with a round knock-out punch. SKU # E2-0002-06
3. Place a rubber washer (8) onto the probe body (9). Insert the button probe into the machine with the 2 threaded tips placed towards the "outside" of the machine wall. Place a rubber washer (7) on the outside of the machine, over the button probe body. Place the plastic washer (6) over the rubber washer. Tightly secure the button probe to the wash tank with the plastic basin nut (5). See FIGURE 3.

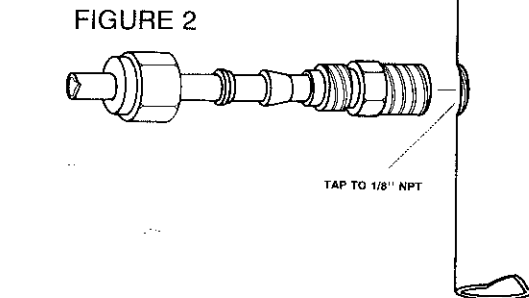
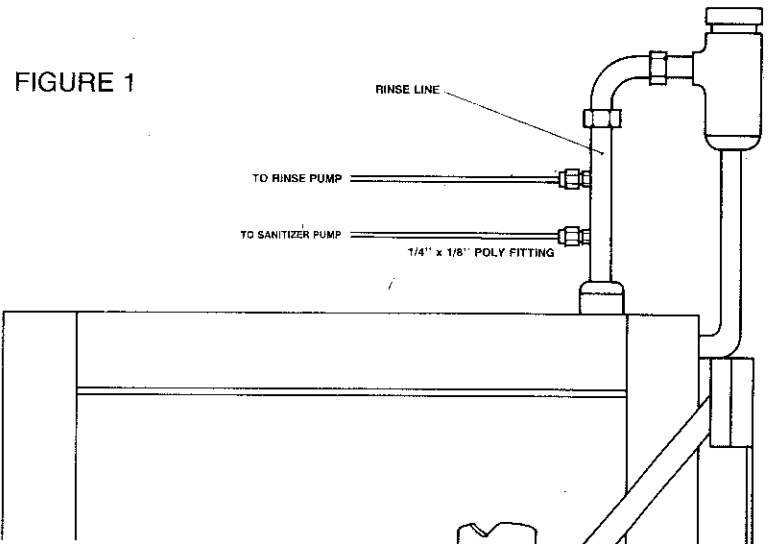

4. Connect the 2 small ring terminals (3) to the 2 conductor wire. Fasten the ring terminals to the threaded probe tips using the S.S. washer (2) and the nut (1).

NOTE: To prevent erratic probe operation, make sure all terminal connections are secure.

Extra insulated ring terminals are available by ordering SKU # E2-0029-01.

5. Route the other end of the 2 conductor wire to the Control Panel via the bottom panels plastic cord entrance fitting. Connect the wire strands to the terminals labeled "Probe" on the 5 connector Detergent terminal block.

NOTE: The Auburn WCT 90-2 porcelain probe will continue to be available special order. SKU # E2-0002-05

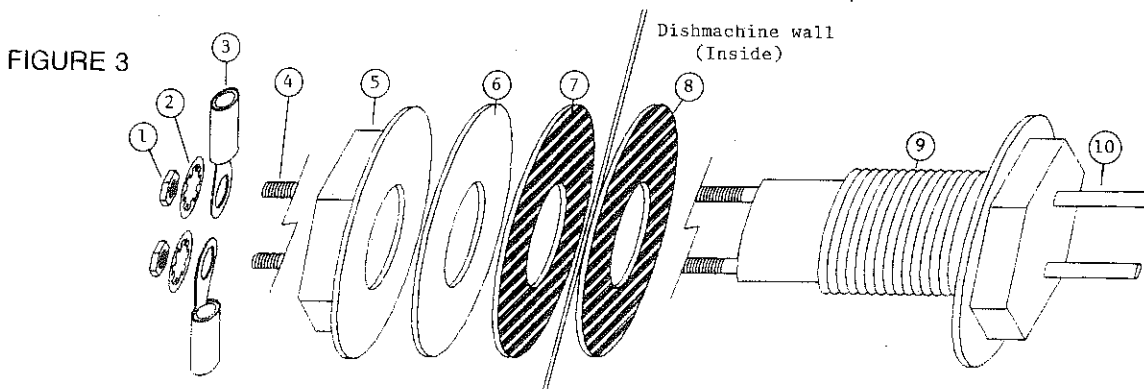

LIBERTY™ MODELS F2, F3, AND FD3 DETERGENT DISPENSERS

The Freedom System™ Dispenser is used in conjunction with the LIBERTY™ concentration controller and is designed to be used only with Freedom System™ disposable canisters containing specially formulated warewashing concentrates. The dispenser is mounted higher than, but within four feet of the dishmachines detergent injection point. Select a mounting location that does not interfere with normal dishmachine operation, yet allows for easy access to insert and remove the disposable canisters.

1. Use the dispenser mounting template (pg. 11) to mark the four holes on the mounting surface. Drill four 1/4" holes and secure the dispenser, utilizing the wall anchors and screws provided. If replacing an E.L. Powder Activator, the same top two mounting holes can be used.
2. Select a location on the dishmachine wash tank for the detergent injection point. Insure the detergent injection point is above the wash tank high water level and below the dishrack or conveyor driving mechanism. Drill and punch a 7/8" hole and install the hose barb fitting. Secure with the rubber and plastic washers and the locknut.
3. Cut to required length the 5/8" id x 7/8" od PVC tubing (2) coming from the bottom of the dispenser and connect to the hose barb fitting on the dishmachine. Insure the tubing is routed in a downward direction with no kinks or loops.
4. Remove the red cap from the nozzle arm assembly and screw the vacuum breaker assembly on. **DO NOT** remove the balls from the tube. The valve balls must remain with the rubber ball on the bottom for the safety valve to operate properly. The safety valve stops the flow of water to the dispenser without a concentrate canister being inserted. This valve eliminates any wiring between the dispenser and the Chem-Tron board.

SOLENOID VALVE AND VACUUM BREAKER

NOTE: Use pipe dope or teflon tape on all plumbing connections.

5. Locate a nearby constant pressure, domestic hot water source and install an 1/8" npt x 1/4" copper compression needle valve. A 1/8" female pipe thread is required for this fitting. (Insure water line is shut off.)

NOTE: SOME PLUMBING MODIFICATIONS MAY BE NEEDED. CHECK WITH STATE AND LOCAL CODES ON PLUMBING REQUIREMENTS.

WARNING TO THE INSTALLER

Water directed to unit should not exceed 150°F. Take hot water from source preceding booster heater.

PARTS LIST

Key #	SKU #	Qty.	Description
1	E2-0002-14	1	Freedom Retro Dispenser (With Installation Kit)
2	E2-0033-02	5'	5/8" ID x 7/8" OD PVC Tubing
3	E2-0255-04	1	1/4" Vacuum Breaker (Metal)
4	E2-0076-02	1	1/4" Poly x 1/4" MPT Straight
5	E2-A041-02	8'	1/4" Poly Flow Tubing
Not Pictured	E2-0010-12	1	S.S. Spray Nozzle w/vane
Not Pictured	E2-0041-05	1	2001 Mounting Kit
Not Pictured	E2-0059-12	1	1/2" Ball Brass
Not Pictured	E2-0053-12	1	Rubber Ball
7	E2-0016-02	1	1/4"cc x 1/4"NPT Brass Straight
Not Pictured	E2-0011-02	1	1/4"cc x 1/8"NPT Needle Valve
Liberty™ F2	E2-0045-05		Installation Kit
Liberty™ F3	E2-0046-05		Installation Kit

6. Connect and route a length of 1/4" copper tubing from the needle valve to the water solenoid valve inlet connector. (7).

Route and connect a length of 1/4" poly-flow tubing (5) from the output side of the solenoid valve (8) up to the inlet side of the vacuum breaker (4) located on the Freedom™ dispenser. (See FIGURE 5)

Run the 1/4" poly-flow from the solenoid valve thru the strain relief (6) on the mounting screw. (See FIGURE 5)

7. The needle valve is used to control the water flow rate into the Detergent dispenser. Optimum results are obtained by adjusting the needle valve to produce a flow of approximately 300 to 350 mls. of water in 15 seconds.

Use the needle valve calibration test kit containing the measuring cup and switch to assist in properly calibrating the Freedom Systems™ water flow.

If you do not have this kit, one may be obtained by ordering SKU #E2-0050-05

8. Remove the pressure sensitive shipping seal from the mouth of the Freedom System™ canister and insert the canister into the top of the dispenser.

When the LIBERTY™ System calls for detergent, the water solenoid valve is activated. Water is then allowed to flow into the dispenser, mixing with the concentrate and flows from the bottom of the dispenser into the dishmachine wash tank via the 7/8" od PVC tubing (2).

9. Regular adjustment procedures are used to calibrate this system as outlined on page 8.

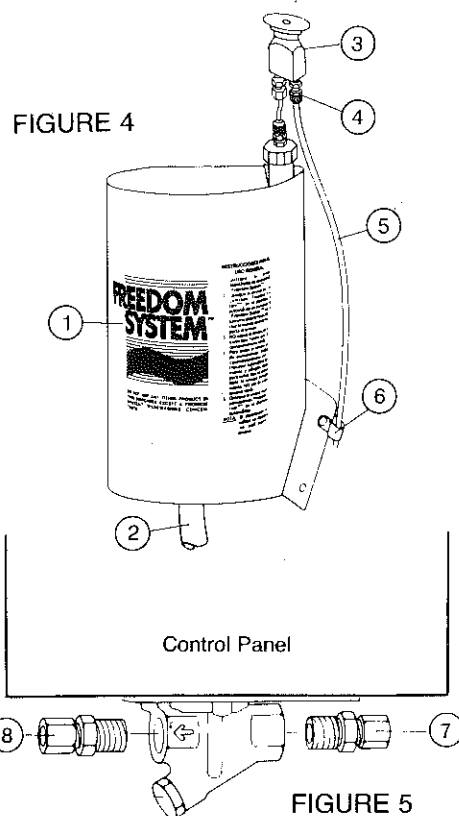

LIBERTY™ MODELS R2, R3, AND RD3 DETERGENT DISPENSERS

1. Drill two 1/4" mounting holes through the back of the reservoir (2). 1" from the top and 2" from the side and then into the mounting surface.
2. Select the side of the reservoir to mount the hose barb fitting (4). Drill a 3/8" hole and punch to 7/8", approximately in the center and install the hose barb fitting so that it points downward. Secure with the rubber and plastic washers and locknut.
3. Insert the slotted end of the S.S. spray arm (1) into the appropriate hole on the cover. Snap the S.S. spray arm into place via the 2 clips inside of the 901 reservoir.
4. Use pipe dope or teflon tape on the 2 1/4" x 1/4" npt brass fittings (6). Insert fittings into the vacuum breaker.
5. Connect the vacuum breaker's outlet fitting (6) to the S.S. spray arm (1). (See FIGURE 6) Secure the reservoir to the mounting surface with the hardware provided.

NOTE: Water must flow in the direction of the arrow stamped on the vacuum breaker (5).

SOLENOID VALVE AND VACUUM BREAKER

NOTE: Use pipe dope or teflon tape on all plumbing connections.

6. Locate a nearby constant pressure, domestic hot water source and install a 1/8" npt x 1/4" copper compression needle valve. A 1/8" female pipe thread is required for this fitting. (Insure water line is shut off.)

WARNING TO THE INSTALLER

Water directed to unit should not exceed 150°F. Take hot water from source preceding booster heater.

NOTE: SOME PLUMBING MODIFICATIONS MAY BE NEEDED. CHECK WITH STATE AND LOCAL CODES ON PLUMBING REQUIREMENTS.

PARTS LIST

Key #	SKU #	Qty.	Description
1	E2-0284-02	1	Stainless Steel Spray Arm (1002)
2	E2-0267-04	1	1 Gal. Reservoir (1002)
3	E2-0033-02	5'	3/8" ID x 7/8" OD PVC Tubing
Not Pictured	E2-0132-09	1	Detergent Fill Level Sticker
Not Pictured	E2-0007-05	1	Complete Kit Pictured (901)
7	E2-0016-02	1	1/4" cc x 1/4" NPT Brass Str.
8	E2-0076-02	1	1/4" poly x 1/4" NPT Brass Str.
Not Pictured	E2-0011-02	1	1/2" cc x 1/4" NPT Needle Valve
Liberty™ R2	E2-0047-05		Installation Kit
Liberty™ R3	E2-0048-05		Installation Kit

7. Connect and route a length of 1/4" copper tubing from the needle valve to the water solenoid valve inlet connector (7).

Route and connect a length of 1/4" poly-flow tubing (9) from the output side of the solenoid valve (8) up to the inlet side of the vacuum breaker fitting, using the 1/4" brass tube support on the vacuum breaker fitting (10). (See FIGURES 6 and 7)

8. Select a location on the dishmachine wash tank for the detergent injection point. Insure the detergent injection point is above the wash tank high water level and below the dishrack or conveyor driving mechanism. Drill a 3/8" hole and punch to 7/8" and install the hose barb fitting. Secure with rubber and plastic washers and locknut.
9. Cut the required length of 3/8" id x 7/8" od PVC tubing (3) and connect to the two hose barb fittings. Insure the tubing is routed directly with no kinks or loops.
10. When the LIBERTY™ System calls to feed detergent, the water solenoid valve is activated. Water is then allowed to flow into the reservoir, mixing with the powdered detergent, and overflow out of the reservoir into the dishmachine wash tank via the 7/8" od PVC tubing. Adjust the needle valve for proper water flow.
11. Regular adjustment procedures are used to calibrate this LIBERTY™ System as outlined on page 8.

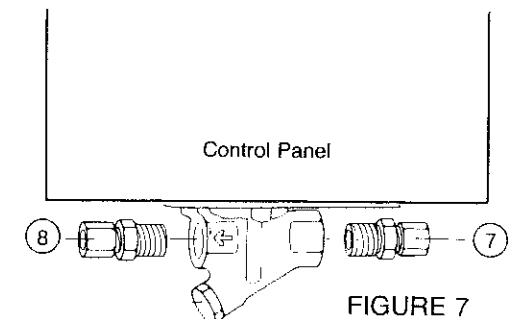
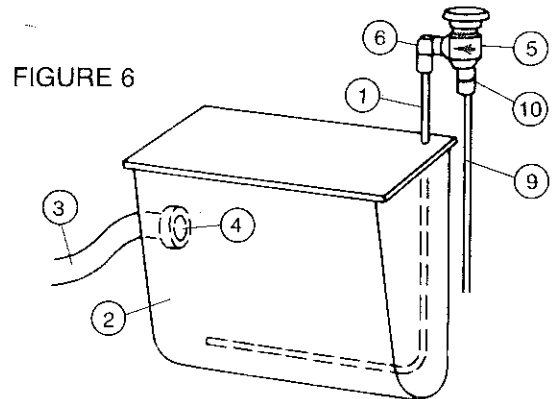

INSTALLATION PERISTALTIC PUMPS

1. FIGURE 8 illustrates the pump assembly less tubing.

NOTE: The interior rotor design has engraved markings for the position of the rollers.

- Position "A" is for Detergent, Sanitizing or Destaining applications.
- Position "B" is for Rinse applications.

2. Remove the 4 nuts from the pump head(s). Remove the entire pump head assembly from the standoff screws. Remove the faceplate from the pump head.

3. Assemble the pump heads as illustrated in FIGURE 9.

NOTE: The Rinse pump uses the 1/8" id x 3/8" od peristaltic pump tubing. (SKU # E2-0431-04)

The optional Sanitizing or Destaining pumps use the 1/4" id x 7/16" od peristaltic pump tubing. (SKU # E2-0394-04)

While rotating the spider clockwise, (a phillips screwdriver works best) push the peristaltic tubing into the pump housing to center over the rollers on the spider. Using silicone grease, generously grease the pump housing and the peristaltic pump tubing.

Replace the faceplate. To assist in assembly, a pump assembly clip (SKU # 06-66) is available. With a phillips screwdriver, rotate the spider back and forth to lubricate the interior of the pump housing.

Place the pump housing back onto the 4 stand-off screws. Rotate the spider with the phillips screwdriver so that the spider lines up and falls into place with the motors drive shaft.

RINSE PERISTALTIC PUMP - ALL MODELS

1. Cut a 4" piece of 3/16" Impolene tubing and insert it into the suction (left) side of the pump head tubing. Secure with pull ties.
2. Connect the Rinse standpipe tubing to the 4" piece of 3/16" Impolene tubing. Secure with pull ties.
3. Measure and cut an appropriate length of 3/16" Impolene tubing connected to the Rinse injection fitting and insert the 3/16" Impolene into the discharge (right) side of the pump head tubing. Secure with pull ties. (See FIGURE 9)

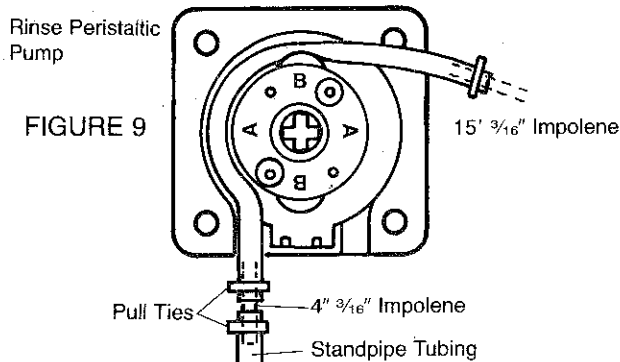

FIGURE 9

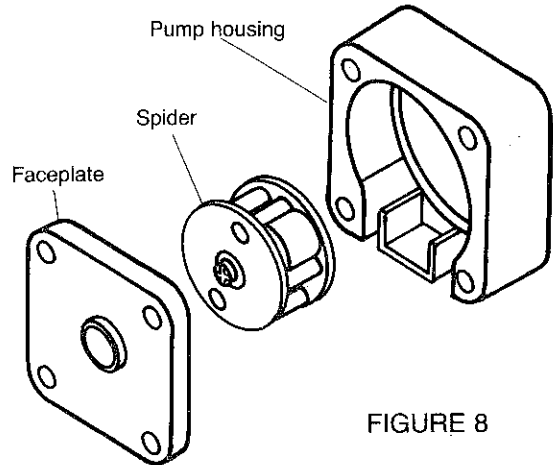

FIGURE 8

INSTALLATION/DESTAINING

OPTIONAL DESTAINING PERISTALTIC PUMP - MODELS FD3 and RD3

1. Install the 3/8" poly x 1/2" straight plastic fitting through the side of the dishmachine at a point approximately 3" above the water level in the wash tank. To install this fitting, drill a 3/8" hole and enlarge to 7/8" with a knock out punch SKU # E2-0002-06. Connect the 15' of 1/4" id x 3/8" od flexible pvc tubing to the fitting as illustrated in FIGURE 10.
2. Insert the two 1/4" hose barbs into the suction and discharge ends of the Destaining pump head tubing. Secure with pull ties.
3. Connect the Destaining standpipe tubing to the hose barb on the suction (left) side of the pump head tubing. Secure with pull ties.
4. Measure and cut an appropriate length of the 3/8" od flexible pvc tubing connected to the Destaining injection fitting and connect the tubing to the hose barb on the discharge (right) side of the pump head tubing. Secure with pull ties. (See FIGURE 11)

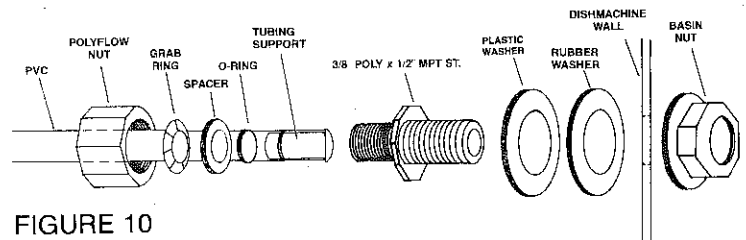

FIGURE 10

OPTIONAL SANITIZER PERISTALTIC PUMP - MODELS F3 and R3

1. Insert the 1/4" hose barb into the suction (left) side of the pump head tubing. Secure with pull ties.
2. Connect the Sanitizer standpipe tubing to the hose barb on the suction (left) side of the pump head tubing. Secure with pull ties.
3. Measure and cut an appropriate length of 1/4" polyflow tubing connected to the Sanitizer injection fitting and insert the 1/4" polyflow tubing into the discharge (right) side of the pump head tubing. Secure with pull ties. (See FIGURE 11)

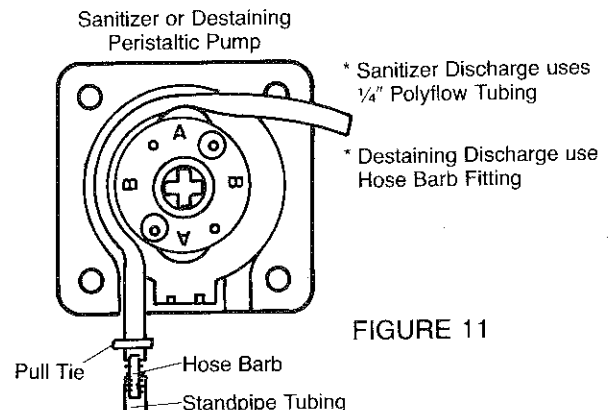

FIGURE 11

ELECTRICAL CONNECTIONS

NOTE: Check and comply with all state and local electrical codes.

1. Turn off all power to the dishmachine before making any electrical connections.
2. Wiring should always conform to local electrical codes. A ground lug is provided in the control panel to comply with these codes.
3. In the dishmachines control panel, locate a source of power which will be present during the wash cycle. Measure the power source with a voltmeter.

Turn off all power to the dishmachine. Connect the hook-up wire to these terminals and run the hook-up wire back to the LIBERTY™ Systems "Detergent" terminal block according to the indicated voltage. (Use sealtight as required.)

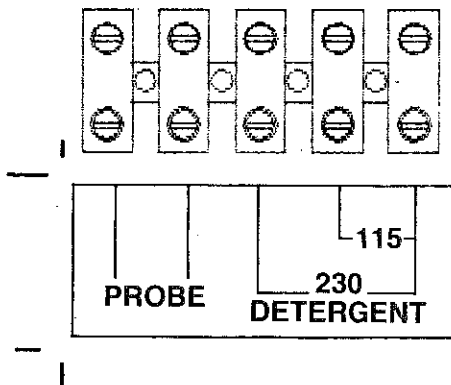

4. Locate the wires leading to the dishmachines "Rinse" solenoid valve.

With a voltmeter, measure the voltage on these wires.

Turn off all power to the dishmachine. Connect the hook-up wire to these terminals and run the hook-up wire to the LIBERTY™ Systems "Rinse" terminal block according to the indicated voltage. (Use sealtight as required.)

5. If desired, an optional remote pressure switch is available for the Rinse activation. (SKU # E2-0040-05) Installation instructions are found on page 10.

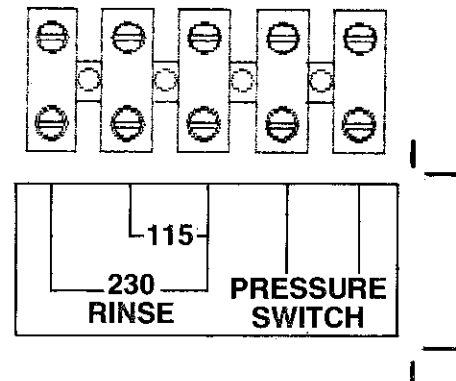

SYSTEM TEST & CALIBRATION

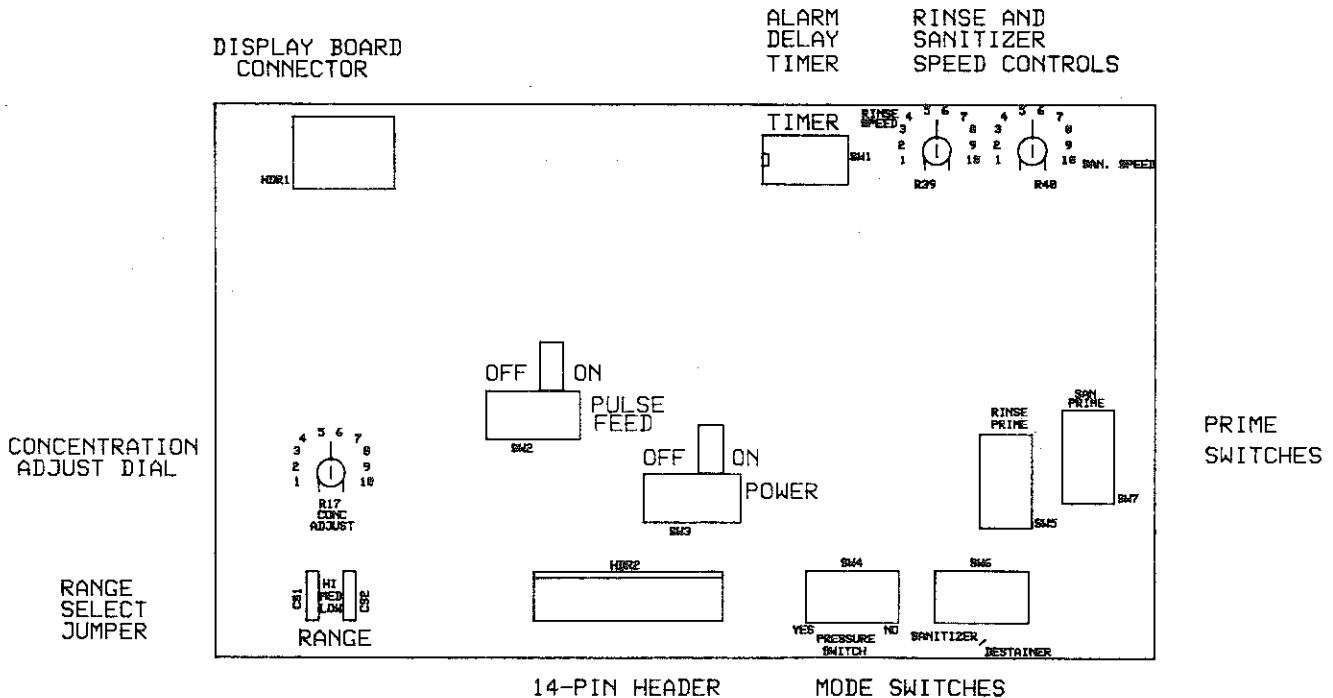

SYSTEM TEST & CALIBRATION

Refer to drawing on page 7

Insure all installation steps, plumbing and electrical connections are complete prior to operation. Insure power is restored to the dishmachine and product is available.

1. **ALARM DELAY TIMER** — Set the control board alarm delay timer switch to #7 (64 seconds). Press it towards "ON". See figures 14 and 15 for examples. (Page 9)

The timer is activated when the control board begins feeding detergent into the dishmachine. If the concentration does not increase to the set level before the timer runs out, the alarm will sound and the red flashing Check Detergent Supply indicator will illuminate to alert the operator of low product supply. When the alarm sounds, the control board will turn the detergent dispenser "off". After the product has been replenished, the system is reset and ready to operate when the dishmachine is turned off and then turned back "on" again.

In the case of a system malfunction, the control board will turn the detergent dispenser "off" to prevent overfeeding.

2. **ON/OFF POWER SWITCH** — Turn the control boards power switch "off". Fill the dishmachine with fresh water. Turn the control boards power switch "on". Activate the dishmachine. The green power and yellow dispensing indicators will light on the front panel and the Detergent dispenser should activate. When the dispensing indicator goes out, turn the dishmachine off and check the alkalinity level of the wash tank water. (See instructions accompanying the alkaline test kit.)

3. **CONCENTRATION ADJUSTMENT DIAL** — The concentration adjustment dial on the control board is used to determine the detergent concentration levels. Either increase or decrease the dial setting as required and continue activating the dishmachine and titrating the wash tank water until the desired detergent concentration is set.

4. **RANGE SELECT JUMPER** — For nearly all installations, the range select jumper may be left in the medium position, where it is factory pre-set. There are however, some locations where water is so conductive that medium or normal settings of the control board will not result in a high enough detergent concentration. In these instances, move the range jumper to the "HI" position.

On the other hand, abnormal water conditions may cause a detergent concentration that is too high at the medium or normal settings of the control board. Moving the range jumper to the "LOW" position will rectify this problem.

5. **PULSE FEED SWITCH** — With the pulse feed switch in the "ON" position, the control board will activate the Detergent dispenser every 2-3 seconds. This permits the product which has been dispensed, to mix with the wash tank water before the control board takes the next reading and decides whether more detergent needs to be added, which reduces over-feed of detergent.

In addition, there is a short delay at the start of each cycle before the system will start to feed, so that a wash tank which may have been inactive for a period of time, will be well mixed before the control board monitors the detergent level.

NOTE: AFTER THE DISHACHINE HAS BEEN FILLED WITH FRESH WATER, THE CONTROL BOARD

WILL SENSE THAT THE CONCENTRATION IS FAR BELOW THE SET LEVEL AND OVER-RIDE THE PULSE FEEDING UNTIL THE CONCENTRATION HAS BEEN INCREASED NEAR THE SET POINT. IT WILL THEN RESUME PULSE FEEDING.

6. **PRIME SWITCHES** — To prime the "Rinse" pump and/or the optional "Sanitizer" pump, slide the prime switch buttons upwards to the "PRIME" position. When priming has been completed, slide the switch buttons back to their lower position or "OFF".

Each time the dishmachines Rinse solenoid valve is activated, the Rinse and/or the optional Sanitizer pumps should turn on.

7. **RINSE AND SANITIZER SPEED CONTROLS** — The pump output rates are governed by the speed control dials located at the upper righthand corner of the control board. Turning the dials clockwise increases the speed and amount of product injected.

The Rinse pump dial should be adjusted according to the observation of the sheeting action on glasses or silverware.

8. **REMOTE PRESSURE SWITCH** — This switch allows the system to operate either with or without a remote pressure switch. If no pressure switch is being used for the Rinse application, slide the switch button towards the "NO" position. If utilizing a remote pressure switch, slide the switch button towards the "YES" position.

9. **SANITIZING DURING RINSE CYCLE** — For Sanitizing purposes, the mode switch located at the bottom righthand corner of the control board must be pressed towards "SANITIZER".

The optional Sanitizer pump should be adjusted so that the final Rinse water contains 50-100 ppm. of chlorine. This is most effectively determined by testing the water on a rack of dishes immediately after the completion of the Rinse cycle. **(Comply with local governing sanitary codes)**

10. **DESTAINING DURING THE WASH CYCLE** — For destaining purposes, the mode switch located at the bottom righthand corner of the control board must be pressed towards "Destainer".

The destaining pump functions at the same time as the Powder Detergent dispenser but at an adjustable rate via the Sanitizer speed control dial. Concentration will vary due to environmental conditions, therefore adjust the Sanitizer speed control dial according to the observation of stain removal on glasses or silverware which contains at least 50-100 ppm. of chlorine.

11. **DISPLAY BOARD CONNECTOR** — This connector is used to connect the control board to the display board via the phone type cable.

12. **14 PIN HEADER** — When it becomes necessary to change the control board in a Liberty™ system, it is crucial to properly align the wiring harness assembly connector to the 14 pin header on the control board. **Misalignment of the connector may cause serious damage to the control board.**

Therefore, before applying power to the system, double check to see that none of the pins from the 14 pin header remain outside of the connector.

ALARM DELAY TIMER PROGRAMMING

In the upper righthand corner of the control board is a block of 7 switches. They determine the amount of time that the detergent dispenser will be allowed to run before the "Check Supply" indicator and buzzer are activated. Pressing a switch toward the number will cause its corresponding time value (Table 1) to be added to the time delay. Switches pressed down to "off" are not used. See FIGURE 14 and 15 for examples.

TABLE 1

SWITCH NO.	TIME IN SECONDS
1	1
2	2
3	4
4	8
5	16
6	32
7	64
All	127

In FIGURE 14, switches 2 and 5 have been pressed toward "ON" and the other switches remain down towards the numbers or "OFF". This represents a setting of 2 + 16 or 18 seconds.

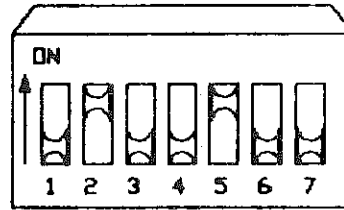

FIGURE 14

In FIGURE 15, switches 3 and 6 have been pressed toward "ON" and the other switches remain down towards the numbers or "OFF". This represents a setting of 4 + 32 or 36 seconds.

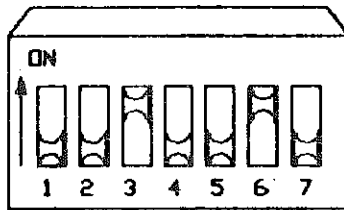

FIGURE 15

COMPLETE WAREWASHING SYSTEMS INSTALLATION

1. The mounting of the Control Panel, Rinse fittings, Sanitizer fitting and the mounting of the dishmachine probe is the same as outlined on page 3.

NOTE: For System 2, use the $\frac{3}{16}$ " x $\frac{1}{8}$ " Brass Straight for the Rinse injection fitting.

For System 3, use the $\frac{3}{16}$ " x $\frac{1}{8}$ " S. S. Straight for the Rinse injection fitting.

2. The assembly of the rinse peristaltic pump is the same as outlined on page 6.
3. The assembly of the Detergent peristaltic pump is the same as outlined on page 6, under the Destaining peristaltic pump headline.
4. The assembly of the Sanitizer peristaltic pump is the same as outlined on page 6, under the Optional Sanitizer peristaltic pump headline.
5. The Sanitizer injection fitting on the Warewash 3 system is installed the same as outlined on page 3.
6. The Electrical connections are the same as outlined on page 7.
7. Operation of the Rinse and/or Sanitizer pumps is the same as outlined on page 8.
8. The Detergent calibration of the Warewashing systems is the same as outlined on page 8, only the Detergent pump will operate instead of the Powder Detergent dispenser.
9. The alarm delay timer programming is the same as outlined on page 9.

REMOTE PRESSURE SWITCH

INTERNAL MOUNTED PRESSURE SWITCH — INSTALLATION

INSTALLATION KIT INCLUDES:

SKU #	Item	Qty.
E2-C041-02	1/4" Polyflow tubing	15'
E2-0340-02	1/4" tube x 1/8" nylon straight	1
E2-0453-02	1/8" x 1/8" x 1/8" brass st. tee	1

Provide a 1/8" tapped NPT hole on the final Rinse line. Most codes require installation at least 6" below the discharge side of an approved vacuum breaker. Use pipe dope or teflon tape on the threads of the brass street tee and install the fitting into the Rinse line.

Connect the 3/16" x 1/8" NPT brass fittings on the straight part of the brass street tee. Insert the cap of the fitting over the 3/16" impolene tubing. Slide the 3/16" impolene tubing all the way thru the brass tee and into the Rinse line. Tighten the cap. Run the 3/16" impolene tubing up the Rinse pump discharge side and insert it into the pump head tubing. Secure with cable ties.

Install the 1/4" tube x 1/8" NPT nylon straight fitting on the 90° part of the brass street tee. Insert the cap of the fitting over the 1/4" polyflow tubing. Connect the 1/4" polyflow to the nylon connector and run the 1/4" polyflow to the 90° brass elbow located on the bottom of the control panel enclosure.

NOTE: ON THIS SYSTEM, IT IS NOT NECESSARY TO JUMP THE RINSE TERMINAL FROM THE DETERGENT TERMINAL WHEN USING A REMOTE PRESSURE SWITCH.

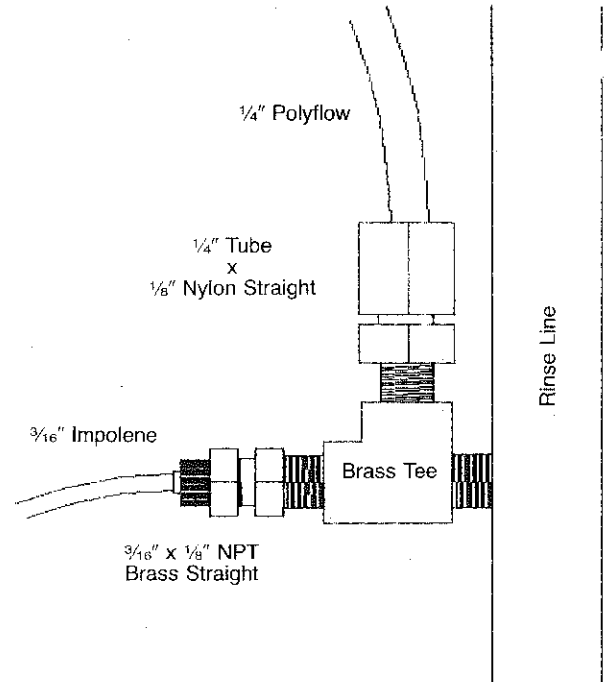

MAKE SURE THE MODE SWITCH THAT IS LABELED PRESSURE SWITCH ON THE CONTROL BOARD IS SET IN THE "YES" POSITION.

ALSO, IF THE OPTIONAL SANITIZER PUMP IS BEING USED, MAKE SURE THE SANITIZER INJECTION FITTING IS INSTALLED DOWNSTREAM FROM THE RINSE INJECTION FITTING.

EXTERNAL MOUNTED PRESSURE SWITCH — INSTALLATION

INSTALLATION KIT INCLUDES:

SKU #	Item	Qty.
E2-0040-05	Remote Pressure Switch assembly	1

Provide a 1/8" tapped NPT hole on the final Rinse line. Most codes require installation at least 6" below the discharge side of an approved vacuum breaker. Use pipe dope or teflon tape on the threads of the brass street tee and install the remote pressure switch assembly into the Rinse line.

Connect the 3/16" x 1/8" NPT brass fittings on the 90° part of the brass street tee. Insert the cap of the fitting over the 3/16" impolene tubing. Slide the 3/16" impolene tubing down thru the fitting and into the brass tee. Tighten the cap. Route the 3/16" impolene tubing up to the Rinse pump discharge side and insert it into the pump head tubing. Secure with cable ties.

Route the 2 conductor wire up to the control panels terminal block labeled "PRESSURE SWITCH".

NOTE: ON THIS SYSTEM, IT IS NOT NECESSARY TO JUMP THE RINSE TERMINAL FROM THE DETERGENT TERMINAL WHEN USING A REMOTE PRESSURE SWITCH.

MAKE SURE THE MODE SWITCH THAT IS LABELED PRESSURE SWITCH ON THE CONTROL BOARD IS SET IN THE "YES" POSITION.

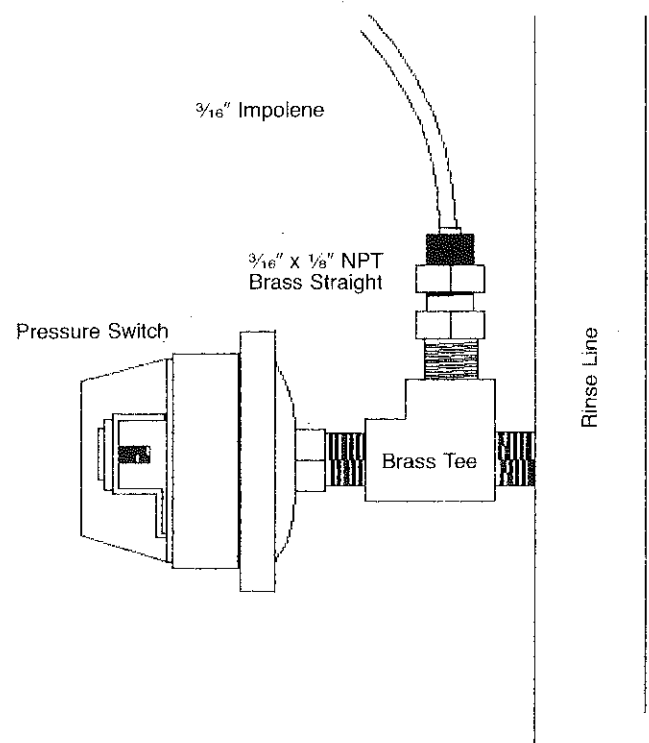

ALSO, IF THE OPTIONAL SANITIZER PUMP IS BEING USED, MAKE SURE THE SANITIZER INJECTION FITTING IS INSTALLED DOWNSTREAM FROM THE RINSE INJECTION FITTING.

**2001 FREEDOM SYSTEM™
DISPENSER MOUNTING TEMPLATE**

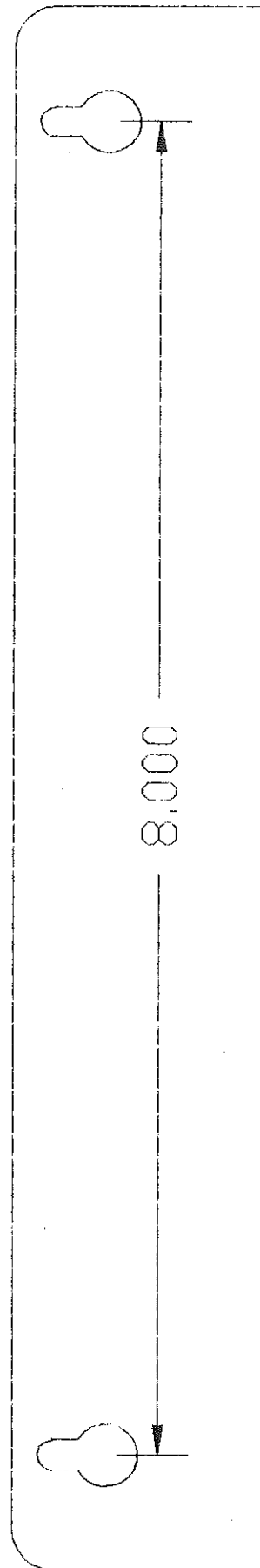
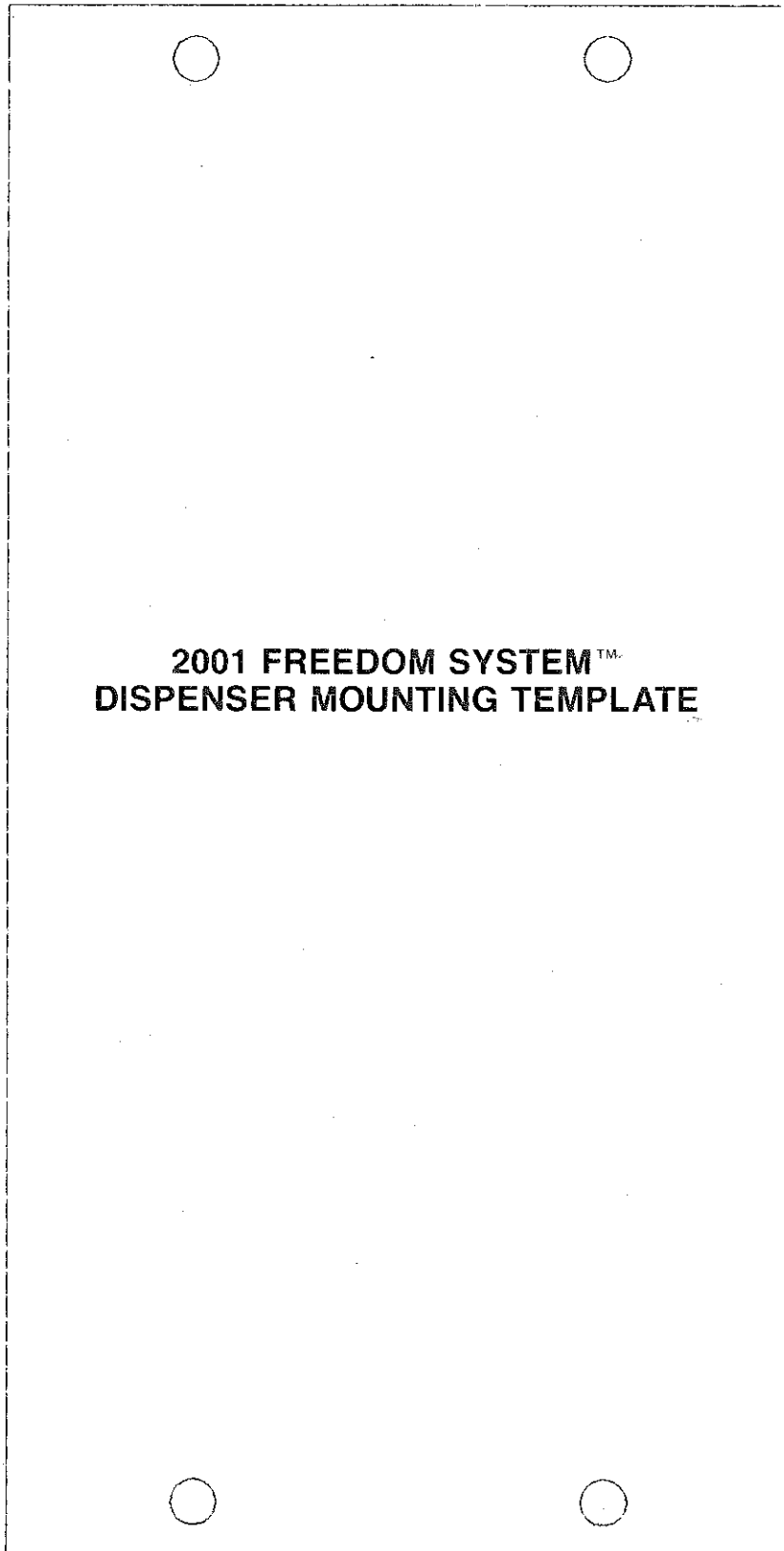

.. SAFETY RECOMMENDATION ..

U S Chemical recommends that when removing a competitor's equipment prior to your installation, be aware that product residue may be left in the dispensing tubes. Proper safety equipment should be worn. Items including safety glasses, rubber gloves, and lab coats are recommended. Contact your company's Safety Director if you have any questions.



316 HART STREET • WATERTOWN, WISCONSIN 53094 • 1-800-424-3068

EQ1634

LWS998CP2M



KIT #K100-015
WATER LEVEL INDICATOR
RETROFIT KIT

Model: 45SA5 series
 20M-NSU series
 Effective S/N: 990362 & lower
 February 15, 2002

A. Purpose

This kit is designed to assist in the replacement of older Water Level Indicators D924A (black metal) and D924B (black plastic) with a new D924C stainless steel unit. The D924A and D924B units fail, by corrosion, due to dishwasher chemicals.

Units with SN 990363 and higher have the D924C stainless steel unit.

B. Parts List

Item #	Qty	Part Number	Description
1	4	D309C-GC-6A	1/4-20 x 3/4" long hex head screw
2	4	D312C-GC-5	1/4-20 locknut
3	1	SK-4540	Template
4	1	ST356A	Hole saw arbor
5	1	ST642	Hole saw, 1-5/8" dia.
6	1	D508	Gasket

C. Directions

1. Remove existing water level indicator and clean both sides of tank.
2. Center template on existing indicator hole.
3. If replacing D924B indicator, drill (4) 17/64" dia. screw holes. Use template as a guide.
4. Bolt template on outside of tank using 1/4-20 fasteners. Make sure template hole is centered on tank hole and that fasteners are tight.
5. With the template as a guide, use the hole saw and arbor to enlarge the existing tank hole to 1-5/8" dia.
 - a. Drill at slow speed, about 300 rpm.
 - b. Use cutting oil.
6. Remove the template and deburr holes.
7. Install the level indicator.
 - a. Place D508 gasket between water level indicator flange and outside of tank.
 - b. Use a small amount of plumber's putty or silicone sealant on both sides of gasket and around screw holes.
 - c. Tighten fasteners securely.

Please call 800/344-4802 for technical service and parts information

File: F:\wp51\kits\K100-015.wpd

ITEM	PARTS NO.	DESCRIPTION	QTY.
1	D924B	WATER LEVEL INDICATOR	1
2	-	RUBBER GASKET (WITH ITEM #1)	1
3	SK-3989	MOUNTING PLATE	1
4	D508	PAPER GASKET	1
5	-	LOCKNUT (WITH ITEM #1)	1
6	D312C-EF-5	#10-32 SEALNUT	4
7	D313C-E1	#10 FLAT WASHER	4

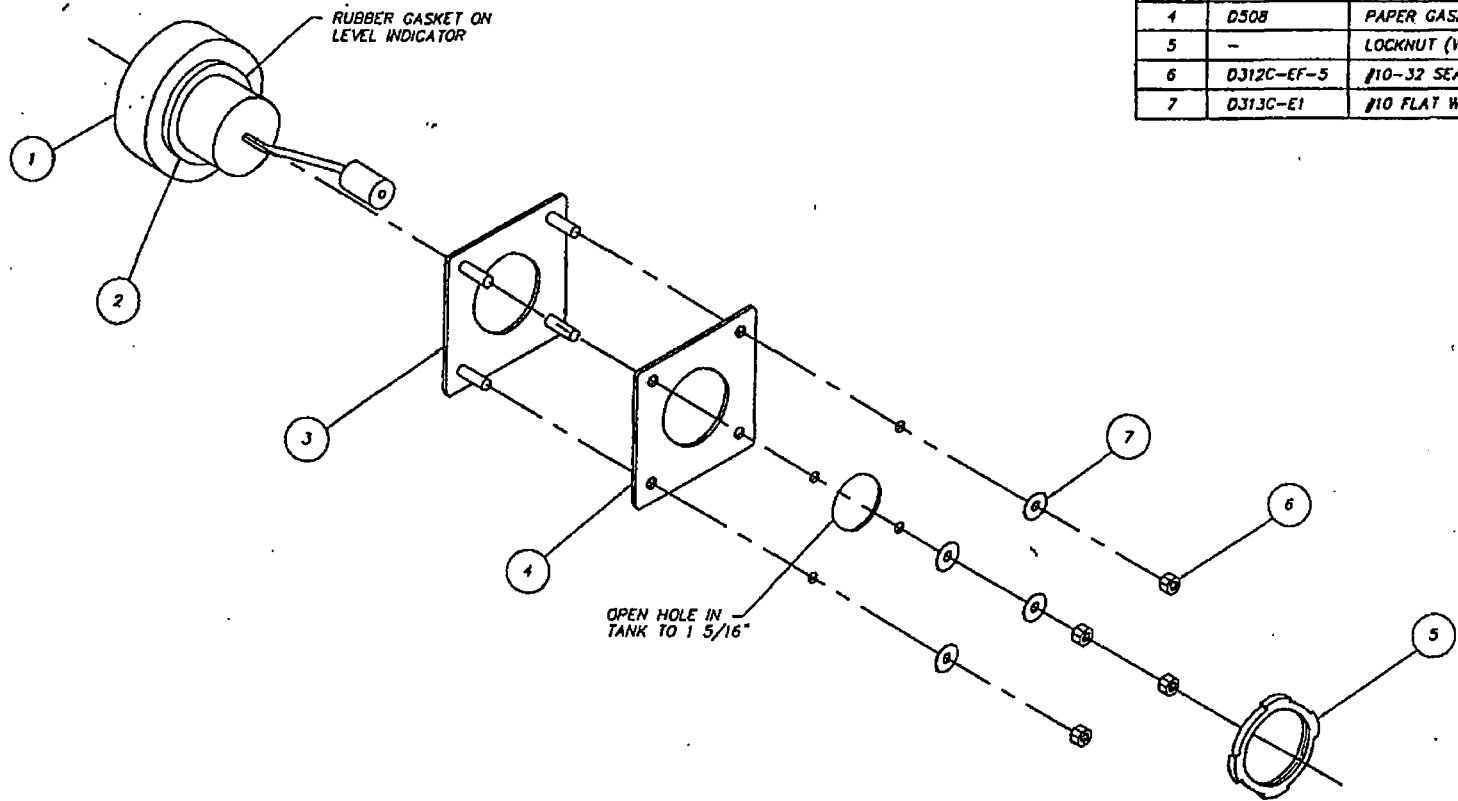

2

			TOLERANCES	TITLE	WATER LEVEL INDICATOR	NEXT ASSY	DWG. NO.
			FRACTIONS ±1/64		RETROFIT KIT - K100-012	REQD -	SK-3990
			DECIMALS				
			.XXX ± .005	MATL		SCALE	USED ON
			.XX ± .01			1-2	
			ANGLES ±1/2°				
REV	ECN NO	DATE	UNLESS OTHERWISE SPECIFIED	Insinger Machine Company		Phildelphia, PA 19135 (215) 624-4800 FAX (215) 624-6966	DRWN/DATE EMM 4.10.97
FILE: SKETCH\SK-3990							

NAVSEA/SPAWAR TECHNICAL MANUAL DEFICIENCY/EVALUATION REPORT (TMDER)

INSTRUCTIONS: Continue on 8 1/2" x 11" page if additional space is needed.
 1. Use this report to indicate deficiencies, problems and recommendations relating to publications.
 2. For CLASSIFIED TMDERs see OPNAVINST 5510H for mailing requirements.
 3. For TMDERs that affect more than one publication, submit a separate TMDER for each.
 4. Submit TMDERs at web site <https://nsdsa2.phdnswc.navy.mil> or mail to: **COMMANDER, CODE 310 TMDER BLDG 1389, NAVSURFWARCENDIV NSDSA, 4363 MISSILE WAY, PORT HUENEME, CA 93043-4307**

1. PUBLICATION NUMBER	2. VOL/PART	3. REV/DATE OR CHG/DATE	4. SYSTEM/EQUIPMENT ID
5. TITLE OF PUBLICATION			6. REPORT CONTROL NUMBER (6 digit UIC-YY-any four:xxxxxx-03-xxxx)
7. RECOMMEND CHANGES TO PUBLICATION			
7a. Page #	7b. Para #	7c. RECOMMENDED CHANGES AND REASONS	
8. ORIGINATOR'S NAME AND WORK CENTER	9. DATE	10. ORIGINATOR'S E-MAIL ADDRESS	11. TMA of Manual (NSDSA will complete)
12. SHIP OR ACTIVITY Name and Address (Include UIC/CAGE/HULL)		13. Phone Numbers: Commercial () ___-____ DSN ___-____ FAX () ___-____	

T6161-FB-FSE-010

FOLD HERE AND TAPE SECURELY
PLEASE DO NOT STAPLE

INCLUDE COMPLETE ADDRESS

USE PROPER
POSTAGE

FOR OFFICIAL USE
ONLY

COMMANDER,
CODE 310 TMDER BLDG. 1389
NAVSURFWARCENDIV NSDSA
4363 MISSILE WAY
PORT HUENEME, CA 93043-4307

FOLD HERE AND TAPE SECURELY
PLEASE DO NOT STAPLE



Insinger Machine Company
6245 State Road
Philadelphia, PA 19135-2996
800-344-4802
Fax: 215-624-6966
www.insingermachine.com