



**TECHNICAL MANUAL**  
**Admiral 44-4 Addendum**

**Admiral 44-4 with optional VRS (Ventless Reclamation System)**  
**Model VRS-10**

Installation, Operation and Maintenance Instructions

Insinger Machine Company  
6245 State Road  
Philadelphia, PA 19135-2996

**800-344-4802**  
Fax 215-624-6966  
[www.insingermachine.com](http://www.insingermachine.com)



Thank you for purchasing this quality Insinger product.

On the space provided below please record the model, serial number and start-up date of this unit:

Model: \_\_\_\_\_

Serial Number: \_\_\_\_\_

Start-Up Date: \_\_\_\_\_

When referring to this equipment please have this information available.

Each piece of equipment at Insinger is carefully tested before shipment for proper operation. If the need for service should arise please contact your local Authorized Insinger Service Company.

A Service Network Listing is provided on our web site, www.insingermachine.com or call Insinger at 800-344-4802 for your local authorized servicer.

For proper activation of the Insinger Limited Warranty a SureFire™ Start-Up & Check-Out Service should be completed on your machine. Refer to the Introduction section in this manual for an explanation of Insinger SureFire™ Start-Up & Check-Out Program.

Please read the Insinger Limited Warranty and all installation and operation instructions carefully before attempting to install or operate your new Insinger product.

To register your machine for warranty by phone, fax or the internet or for answers to question concerning installation, operation, or service contact our Technical Services Department:

TECHNICAL SERVICE CONTACTS	
Toll-Free	800-344-4802
Fax	215-624-6966
e-mail	service@insingermachine.com
Web site	www.insingermachine.com

### TABLE OF CONTENTS

<b>Part 1</b> Technical Information	1-4
<b>Part 2</b> Installation and Connection Instructions	5
<b>Part 3</b> Operating Instructions	6-9
<b>Part 4</b> Maintenance and Repair	10-11
<b>Part 5</b> Electrical Schematics & Replacement Parts	12-13



 Project \_\_\_\_\_ CSI - 11400 \_\_\_\_\_  
 Item \_\_\_\_\_ Approval \_\_\_\_\_  
 Quantity \_\_\_\_\_ Date \_\_\_\_\_

## ADMIRAL 44-4 with optional VRS (Ventless Reclamation System) Single Tank Conveyor Dishwasher

- Automatic conveyor, rack type, single tank dishwasher with recirculating wash and fresh water final rinse.
- 0.63 gallons per rack at 20 PSI
- Capacity is 233 (20" x 20") racks per hour or 5,825 dishes per hour
- VRS heat recovery system
- CrossFire® Wash System provides superior cleaning
- Wide telescoping insulated doors allow for efficient daily cleaning
- Color-coded curtains for error-proof replacement
- No hood required (Refer to your local building code)

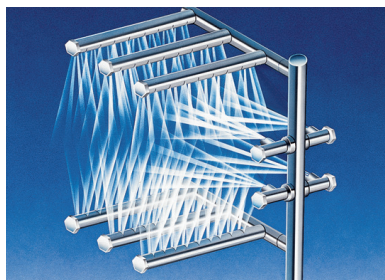

**Telescoping Doors**—no issues with low ceilings. The doors also provide wide access to the interior of the machine for quick and efficient daily maintenance.



The patent-pending **CrossFire® Wash System** power sprays water horizontally, as well as, from above and below, cleaning and sanitizing the dirtiest of ware.

### STANDARD FEATURES

- CrossFire® Wash System
- Telescoping insulated doors
- Color-coded curtains
- Tank heat: heat recovery using a refrigerant compressor
  - Ozone friendly R134A refrigerant
  - High efficiency scroll compressor
  - High and low pressure switches
  - Easy access to gauge ports
- Manifold clean-out brush
- S/S 304 stainless steel construction
- Automatic tank fill
- Low water protection system
- Single point electrical connection: motor, controls and compressor (Optional booster requires a separate connection)
- Detergent connection provision
- Top mounted NEMA 12 control panel
- Door safety switches
- Standard frame drip proof motors
- Energy saver mode
- Override switch for de-liming
- SureFire™ Start-Up & Check-Out Service
- End caps/pipe plugs secured to prevent loss
- Timing belt conveyor drive

### OPTIONS

- Built-in or stand alone electric booster heater
- Pressure reduction valve and line strainer
- Steam booster
- Security package
- Totally enclosed motors
- Rack limit switch
- Power Loader
- Power Unloader
- Door activated drain closer
- Plastic 20" x 20" racks (plate or silver)

**Admiral 44-4 VRS**

#### AUTOQUOTES



6245 State Road • Philadelphia, PA 19135 • PH: 800-344-4802 • FX: 215-624-6966 • www.insingermachine.com



## ADMIRAL 44-4

with optional VRS (Ventless Reclamation System)  
Single Tank Conveyor Dishwasher

Capacity Per Hour	233 racks 5825 dishes 225-500 meals
Tank Capacity	21 gals. (wash)
Motor Size	2 hp (wash) 1/15 hp (conveyor) 1/2 hp (recirculation pump) 10 hp (compressor)
Electric Usage	15 kW b.i. booster 40° rise 27 kW b.i. booster 70° rise 15 kW rem. booster 40° rise 27 kW rem. booster 70° rise
Steam Consumption at 20 psi min.	52 lbs./hour booster 40° rise 91 lbs./hour booster 70° rise
Final Rinse Peak Flow at 20 psi min.	2.5 gallons/minute
Final Rinse Consumption at 20 psi min.	147 gallons/hour 0.63 gallons/rack
Peak Rate Drain Flow	9 gallons/minute
Shipping Weight	750 lbs.

Electrical	VRS	with Steam Booster	with 40° Rise Electric Booster*	with 70° Rise Electric Booster*
208/3/60	46.20	46.20	87.80	121.10
240/3/60	40.51	40.51	76.61	105.51
480/3/60	20.47	20.47	38.47	52.97

\*Booster requires separate electrical connection

### SPECIFICATIONS

**VRS OPERATION**- The VRS (Ventless Reclamation System) works by removing the heat and steam from the warewasher's exhaust vents and returning room temperature air to the surrounding space. The reclaimed heat is recycled to the warewasher's wash tank. The steam and water vapor is returned to the wash tank for reuse.

**CONSTRUCTION**- Hood and tank constructed of 16 gauge type 304 S/S. Hood unit of all welded seamless construction. S/S frame, legs and feet. All internal castings are non-corrosive lead free nickel alloy, bronze or S/S.

**DOORS**- Zero-Infringement Doors are extra large die formed, type 304 S/S, double-walled, insulated, front inspection doors. The vertically opening doors with spring assist, glide in full length tracks on either side. Automatic safety catch at full open locations.

### SPECIFICATIONS (continued)

**CONVEYORS**- One S/S roller chain conveyor, with rack driving lugs every sixth link, running along the front of the machine. Eight free spinning rollers placed along the back wall of the machine. Conveyor accommodates all standard 20" racks. Conveyor drive system includes direct drive gear motor with frictionless, trouble-free clutch system, spring-loaded and automatically re-engaging. Racks conveyed automatically through washing and rinsing systems, powered by an independent 1/15 hp drive motor.

**PUMP**- Centrifugal type "packless" pump with a brass petcock drain. Construction includes ceramic seal and a balanced cast impeller on a precision ground stainless steel shaft, extension or sleeve. All working parts mounted as an assembly and removable as a unit without disturbing pump housing. 2 hp motor, standard horizontal C-face frame, drip proof, internally cooled with ball-bearing construction.

**COMPRESSOR**- A high-efficiency compressor utilizing R-134 refrigerant. The warewasher's water tank is heated by returning the heat that escapes from the warewasher combined with the heat of compression.

**CONTROLS**- Top mounted NEMA 12 control enclosure, housing motor overload protection, contactors, transformers and all other dishwasher controls. All controls safe low voltage 24 VAC.

**ENERGY SAVER**- Rack actuated lever automatically operates the final rinse solenoid only when a rack passes, saving water and energy. The lever also activates an adjustable timer control. If no ware passes during the set time, the machine shuts down.

**SPRAY SYSTEM**- Spray arms made of type 304 stainless steel pipe. Spray assemblies removable without the use of tools.

**WASH**- Upper and lower manifolds with the patented CrossFire® Wash System. One manifold above with 3 power wash arms, each with 5 high pressure cleaning slots and one manifold below with 4 power wash arms, each with 7 high pressure cleaning slots. The slots are precision milled for water control producing a fan spray. Wash arms are fillet welded to the S/S manifold. The CrossFire® Wash System provides 2 horizontally spraying high pressure nozzles.

**FINAL RINSE**- Three nozzles above and four nozzles below threaded into S/S schedule 40 pipes. Nozzle assemblies produce a fan spray reducing water consumption, maximizing heat retention.

**DRAIN**- Drain valve externally controlled. Overflow assembly with skimmer cap is removable without the use of tools for drain line inspection. Heater is protected by low water level control.

Note: Due to product improvement we reserve the right to change information and specifications without notice.

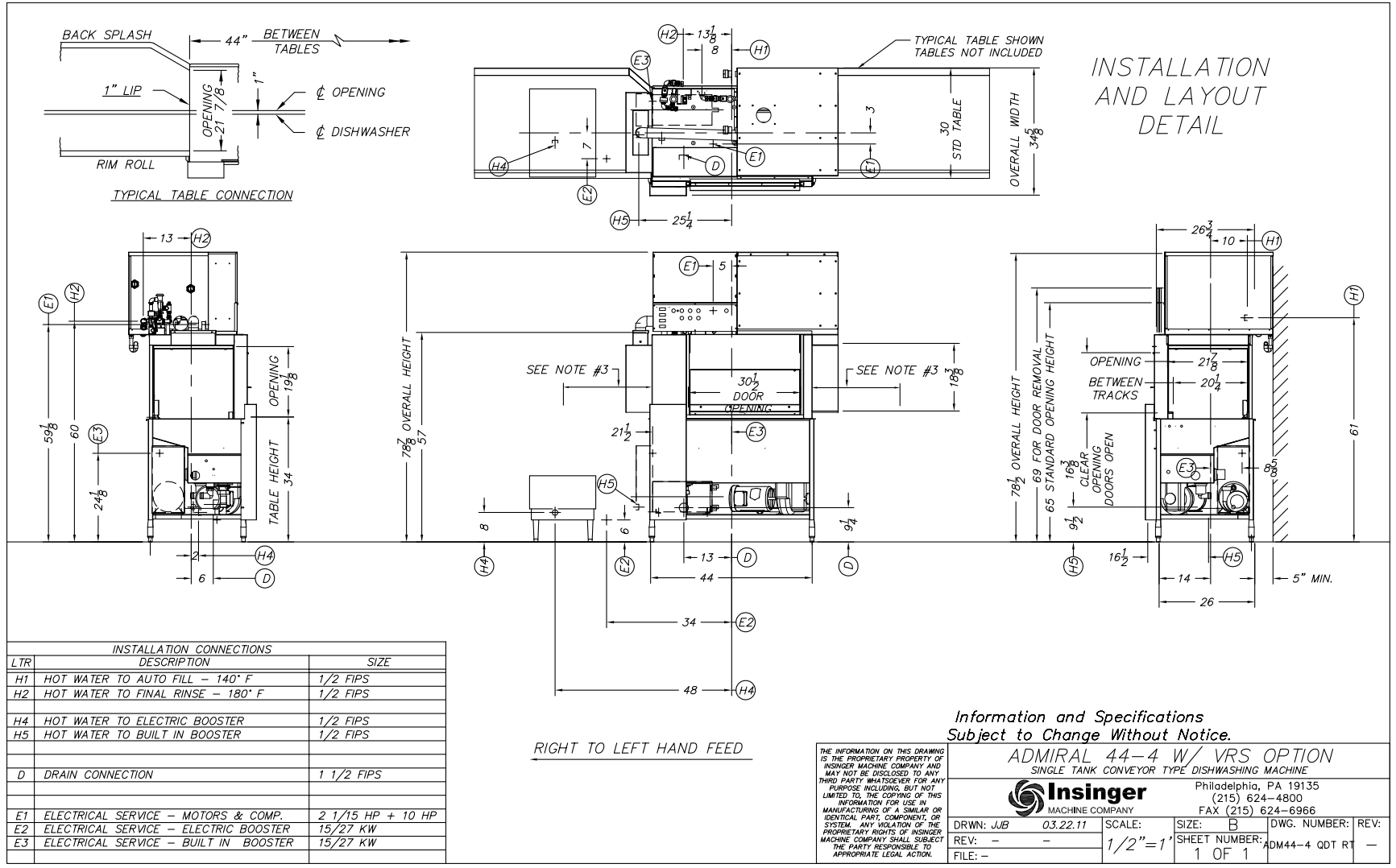
**INSTALLATION AND LAYOUT DETAIL**

INSTALLATION CONNECTIONS		SIZE
LTR	DESCRIPTION	
H1	HOT WATER TO AUTO FILL - 140° F	1/2 FIPS
H2	HOT WATER TO FINAL RINSE - 180° F	1/2 FIPS
H4	HOT WATER TO ELECTRIC BOOSTER	1/2 FIPS
H5	HOT WATER TO BUILT IN BOOSTER	1/2 FIPS
D	DRAIN CONNECTION	1 1/2 FIPS
E1	ELECTRICAL SERVICE - MOTORS & COMP.	2 1/15 HP + 10 HP
E2	ELECTRICAL SERVICE - ELECTRIC BOOSTER	15/27 KW
E3	ELECTRICAL SERVICE - BUILT IN BOOSTER	15/27 KW

RIGHT TO LEFT HAND FEED

Information and Specifications  
Subject to Change Without Notice.

**ADMIRAL 44-4 W/ VRS OPTION**  
SINGLE TANK CONVEYOR TYPE DISHWASHING MACHINE



Philadelphia, PA 19135  
(215) 624-4800  
FAX (215) 624-6966

THE INFORMATION ON THIS DRAWING IS THE PROPRIETARY PROPERTY OF INSINGER MACHINE COMPANY AND MAY NOT BE DISCLOSED TO ANY THIRD PARTY WHATSOEVER FOR ANY PURPOSE INCLUDING, BUT NOT LIMITED TO, THE COPYING OF THIS INFORMATION FOR USE IN THE MANUFACTURING OF A SIMILAR OR IDENTICAL PART, COMPONENT, OR SYSTEM. ANY VIOLATION OF THE PROPRIETARY RIGHTS OF INSINGER MACHINE COMPANY SHALL SUBJECT THE PARTY RESPONSIBLE TO APPROPRIATE LEGAL ACTION.

DRWN: JJB	03.22.11	SCALE: 1/2" = 1'	SIZE: B	DWG. NUMBER: REV:
REV: -	-		SHEET NUMBER: 1 OF 1	ADM44-4 QDT RT -
FILE: -	-			

**Admiral 44-4 VRS (Ventless Reclamation System)****Model VRS-10****INTRODUCTION****Purpose**

The purpose of this technical manual addendum is to provide installation, operation, cleaning and maintenance directions.

A section is provided for replacement parts.

**Scope**

This manual contains all pertinent information to assist in the proper installation, operation, cleaning, maintenance, and parts ordering for the Insinger VRS Ventless Reclamation System. The installation instructions are intended for qualified equipment installers. The operation and cleaning instructions are intended for the daily users of the equipment. The maintenance and parts sections are intended for qualified service and/or maintenance technicians. Replacement parts may be ordered directly from our factory or from your local Insinger Authorized Service Agency. You can speak to the Insinger Technical Services Department, 800/344-4802, or e-mail us at [service@insingermachine.com](mailto:service@insingermachine.com). When calling for warranty information or replacement parts please provide the model and serial number of your Insinger Equipment. The VRS has its own model and serial numbers. These important numbers should be noted in this manual on the spaces provided on the opening page.

**INSTALLATION AND CONNECTION**

The VRS system is a factory installed option and is shipped attached to the warewasher.

Refer to Warewasher installation instructions. These instructions are in addition to the warewasher instructions.

**Check Electrical Connections**

Warewasher to VRS compressor.

Warewasher to VRS fan.

Warewasher to VRS recirculating pump.

Warewasher to VRS fan transformer (480volt units only).

**Setting Up and Alignment:**

The machine must be completely level when installed.

Adjust the machine's feet to compensate for any unevenness of the floor.

Check and retighten connections of unload side ventilation exhaust hose/duct to inlet connection on the VRS.

Check for any water leaks in the VRS grey CPVC water piping.

**Condensate Connection:**

The condensate produced by the VRS unit is directed back into the wash water tank. This is the white ½" PVC tubing from the bottom of the VRS to the back of the unit.

**OPERATING INSTRUCTIONS****OPERATING INSTRUCTIONS for VRS™**

Always refer to the Warewasher's operation instruction for performance of the Warewasher.

These instructions only pertain to the VRS™

**START-UP AND CHECK**

The VRS utilizes a three phase Scroll Compressor which must be rotating in the proper direction (similar to the water pumps). The entire unit has been wired for all components to rotate in the proper direction, if one rotates backward they all rotate backward.

To reverse rotation flip 2 of the incoming power leads, donot try to change rotations on the individual components. Note the scroll compressor makes loud noises when rotating in the wrong direction.

**SEQUENCE of OPERATION**

The VRS unit is intended to heat commercial warewasher wash and/or rinse tank water. It is not intended to heat the final rinse water used on high temperature machines.

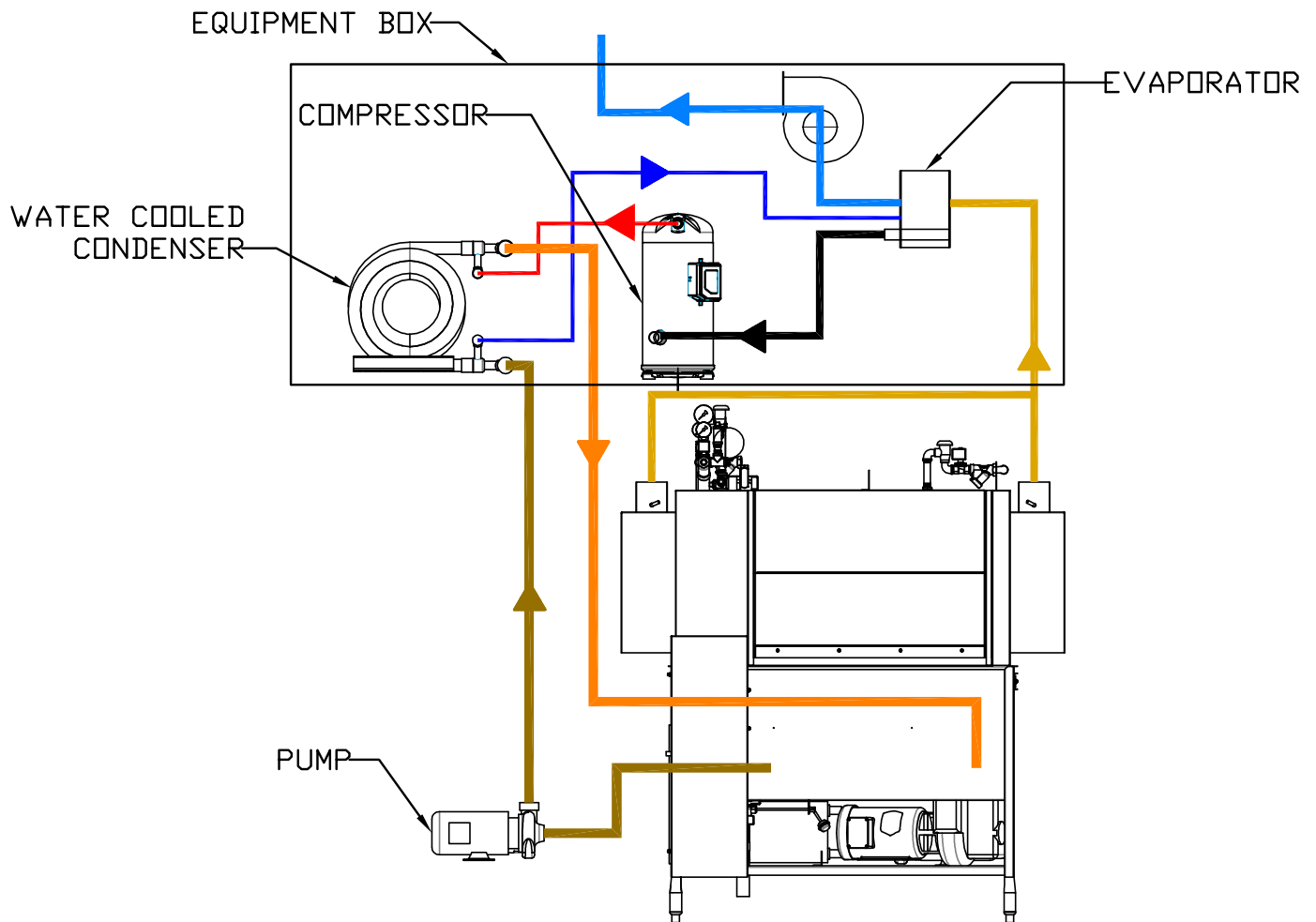
**OPERATING INSTRUCTIONS (continued)**
**Sequence of Operation  
Ventless Reclamation System (VRS)**

- 1. WARM, WET, STEAMY AIR FROM WAREWASHER VENTS TO EVAPORATOR COIL.
- 2. DEHUMIDIFIED DRY AIR FROM EVAPORATOR DISCHARGED INTO WAREWASHER ROOM AT APPROXIMATELY THE SAME TEMPERATURE AS THE ROOM.
- 3. REFRIGERANT SUCTION FROM EVAPORATOR TO THE COMPRESSOR. THE REFRIGERANT ABSORBS THE HEAT FROM THE AIR BEING PASSED THROUGH THE EVAPORATOR AND IS SENT TO THE COMPRESSOR WHERE THE REFRIGERANT IS COMPRESSED AND ITS TEMPERATURE AND PRESSURE ARE RAISED.
- 4. COMPRESSOR REFRIGERANT DISCHARGE TO THE WATER COOLED CONDENSOR. THE WATER COOLED CONDENSOR RELEASES THE HEAT FROM THE REFRIGERANT INTO THE WATER.
- 5. LIQUID REFRIGERANT FROM THE WATER COOLED CONDENSOR FLOWS TO THE EVAPORATOR AND THE REFRIGERANT CYCLE STARTS AGAIN. THE REFRIGERANT CYCLE AND SYSTEM IS A SELF-CONTAINED SYSTEM AND THE REFRIGERANT DOES NOT COME IN CONTACT WITH THE WAREWASHER WATER.
- 6. WAREWASHER WATER IS PUMPED FROM THE WAREWASHER TANK TO THE WATER COOLED CONDENSOR WHERE THE WATER PICKS UP THE HEAT FROM THE REFRIGERANT.
- 7. WATER LEAVING THE WATER COOLED CONDENSOR COIL HAS BEEN HEATED AND IS RETURNED TO THE WARE WASHER TANK SUPPLYING HOT WATER FOR WAREWASHING.

**OPERATING INSTRUCTIONS (continued)**

## Warewasher Components

- Wash Pump
- Recirculation Pump
- Lower water level float
- Upper water level float
- Automatic fill solenoid
- Final Rinse solenoid
- Final Rinse Thermometer
- Final Rinse water Built in Booster
- Wash tank controller/thermometer
- Cool down controller/thermometer
- Compressor
- Evaporator
- Thermostatic Expansion Valve
- Water cooled Condenser
- Hot Gas Bypass Valve

This sequence of operation assumes that the “Sure Fire Start Up” has been completed.

1. Turn supply water to unit “ON”. There may be 2 sources of supply depending on the installation
2. Turn power “ON” to the Booster (if equipped with one) and Warewasher.
3. Close all tank drains
4. Press the orange POWER switch.
  - a. The orange light in the switch will come on
5. The Auto fill solenoid will be powered and water will fill the wash tank. The auto fill solenoid will not come on if the lower float is made.
6. Filling sequence
  - a. Auto fill solenoid is energized when the lower float is open
  - b. Auto fill solenoid is de-energized when the upper float is closed
7. Heating sequence
  - a. On initial start up the recirculation pump and compressor will start once the water level reaches the lower float. Note that after this operation the compressor and recirculation pump will run and cycle on and off from the wash tank controller. Pressing the POWER switch off will turn the compressor and recirculation pump off.
  - b. While the wash pump is off the compressor and recirculation pump will cycle on and off according to the temperature controller
  - c. When the wash pump is on the compressor and recirculation pump will run continuously to maintain temperature and remove steam from the exhaust.

**Washing /Energy Save Sequence.**

1. The START switch is depressed and the wash pump and conveyor will start.
2. The ENERGY SAVER switch is depressed and the white light in the switch will light.
3. As long as racks are going thru the warewasher the wash pump and conveyor will continue to run. If there are no racks going through the machine the wash pump and conveyor will shut down.
4. The START switch will have to be pressed to restart the wash pump and conveyor.

**Delime sequence**

1. Follow your chemical supplier’s recommendations for how often the warewasher should be delimed.
2. Drain the wash tank
3. Remove the scrap screens
4. Fill the wash tank with fresh water
5. Pour into the wash water the chemical supplier’s recommended amount of delimer.
6. Press the START button. The ENERGY SAVER button should be off
7. The wash pump, conveyor and recirculating pump will run.

**HOW THE WATER IS HEATED.**

1. The steam and hot air that normally comes out the warewasher vents and goes up the exhaust duct is directed through a refrigerant evaporator where it is cooled and dehumidified and then the air is returned to the space at approximately the same temperature as the room.
2. The low temperature low pressure liquid refrigerant in the evaporator absorbs the heat from the air and is changed into a gas. This refrigerant gas then goes to the compressor where it is compressed and the refrigerant's temperature and pressure are raised. Coming out of the compressor is high temperature and high pressure refrigerant gas which goes to a water cooled condenser where the refrigerant gas loses heat and changes to a high temperature high pressure liquid. The heat that is removed from the refrigerant is transferred to the water that is flowing through the condenser. The water and refrigerant in the condenser both travel in their own tubes and do not come in contact with each other. The high temperature high pressure liquid refrigerant goes through a metering device which reduces the temperature and pressure. This low temperature low pressure liquid refrigerant then goes to the evaporator and the whole cycle repeats again.
3. The water that is used in the condenser is taken from the wash tank by the recirculation pump and is sent through the water cooled condenser where it is heated by the refrigerant and then returned to the wash tank.

**CLEANING/GENERAL MAINTENANCE**

Follow instructions in Warewasher manual.

**TROUBLESHOOTING**

Faults where it is not necessary to call Insinger. You can rectify minor faults yourself following the steps described in the table below.

If you are unable to rectify the fault, contact Insinger service (1-800-344-4802.)

Do not open any panels or expose any parts of the machine if tools are necessary to do so.

Risk of electric shock.

Work on the electrical equipment should only be performed by service personnel.

First disconnect the washer from the main power.

Do not switch the washer on again until the cause of the fault has been identified.

<b>TROUBLESHOOTING</b>		
<b>Problem</b>	<b>Cause</b>	<b>Remedy</b>
VRS fan not running	No power Motor failed	Check power source Replace motor and blower assy
Compressor not running	No power Water temperature satisfied Loss of refrigerant Compressor	Check power source Wait for water to cool down Contact qualified Service Contact qualified Service
Steam coming out of Warewasher	Fan not running Compressor not running	See above See above

**ELECTRICAL SCHEMATICS &  
REPLACEMENT PARTS**

<b>VRS-10</b>			
<b>208 OR 240V</b>	<b>480V</b>		
<b>QUANTITY</b>	<b>QUANTITY</b>	<b>PART #</b>	<b>DESCRIPTION</b>
-	1	D3250	COPELAND COMPRESSOR ZR125KCE-TFD 460/3/60
1	-	D3251	COPELAND COMPRESSOR ZR125KCE-TF5 200-230/3/60
1	1	D3252	SPACER MOUNTING ZR COMP COPELAND
1	1	D3245	PACKLESS WATER COOLED COND (PER DWG)
1	1	D3246	DX COIL 8 X 12-6R- 38/168 SUPERRAD (PER DWG)
1	1	D3253	LIQUID FILTER DRIER EMERSON EK165S (047618)
1	1	D3255	TXV EMERSON HFES 6 MC 5FT 5/8 X 7/8 ODF S/T (057903)
1	1	D3162	BLOWER PSC 230V 559CFM
1	1	3018-K188B	PUMP 1/2HP TEFC
2	2	1564-139	4" HOSE CONNECTOR
1	1	D3268	FAN GUARD 3.62 FAN NICKEL PLATED STEEL
5.5#	5.5#		REFRIGERANT R134A

Typical wiring diagram. Consult unit for proper diagram.

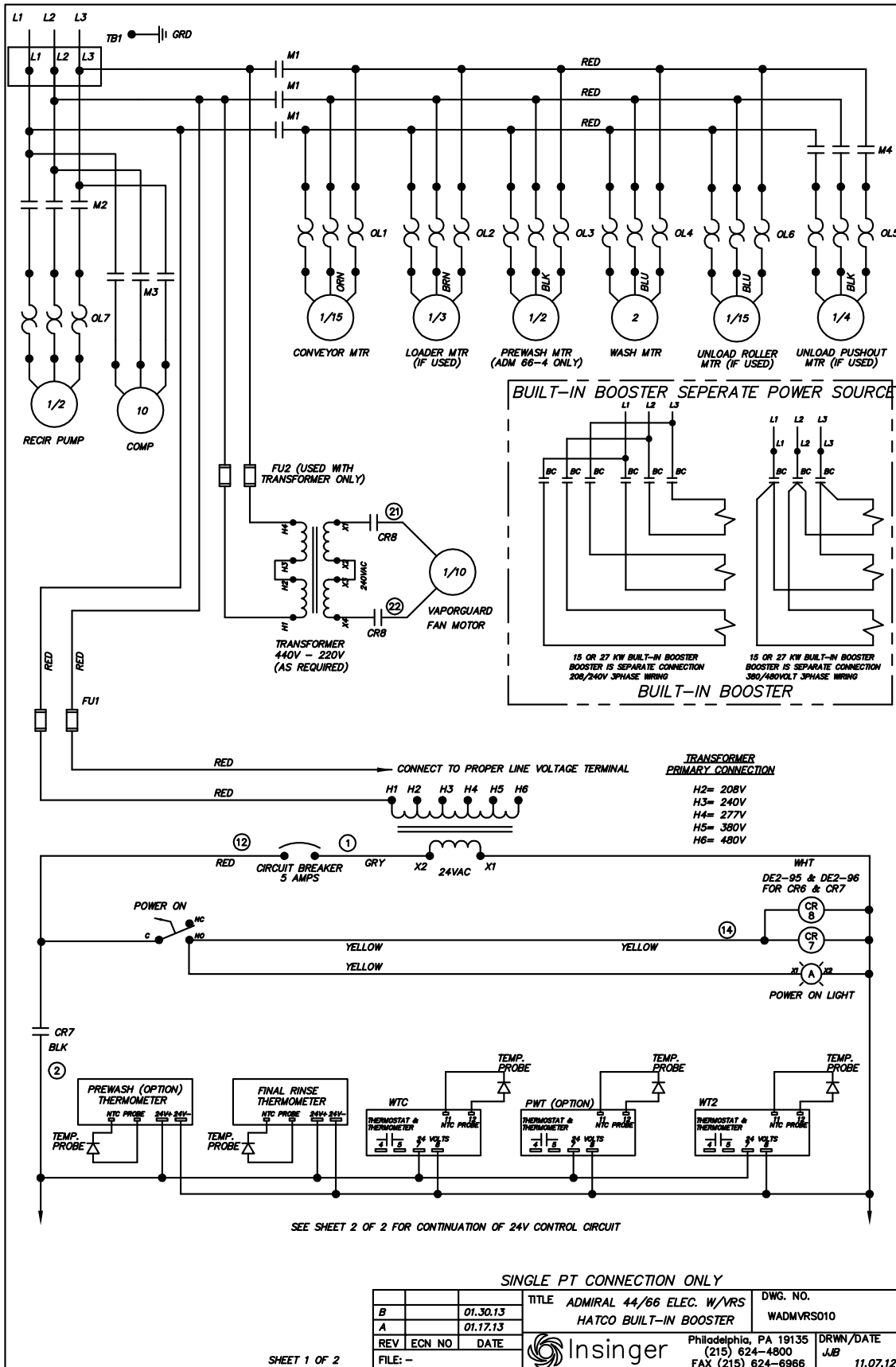

SHEET 1 OF 2

Typical wiring diagram. Consult unit for proper diagram.



SHEET 2 OF 2

TITLE		ADMIRAL 44/66 ELEC. W/VRS		DWG. NO.	
HATCO BUILT-IN BOOSTER		WADMVRE010		Philadelphia, PA 19135	
REV ECN NO DATE		(215) 624-4800		DRWN/DATE	
FILE: -		FAX (215) 624-6966		JJB 11.07.12	



Insinger Machine Company  
6245 State Road  
Philadelphia, PA 19135-2996

**800-344-4802**  
Fax 215-624-6966  
[www.insingermachine.com](http://www.insingermachine.com)