



TECHNICAL MANUAL

Installation, Operation and Maintenance Instructions

COMMANDER 18-3

HIGH TEMPERATURE DOOR TYPE

COMMANDER 18-3

CS-4

Insinger Machine Company
6245 State Road
Philadelphia, PA 19135-2996

800-344-4802
Fax: 215-624-6966
www.insingermachine.com



TECHNICAL MANUAL
including Installation, Operation, and Maintenance Instructions
FOR
DOOR TYPE DISHMACHINES
MODEL: Commander 18-3 / CS-4

18-3
new pump
3018-K39



COMMANDER 18-3/CS-4 INSTALLATION INSTRUCTIONS Section A

A.1 PLACEMENT

- A.1.1 Carefully uncrate machine. Take caution to not damage components which may be mounted on the top or sides of the machine.
- A.1.2 Set unit in place and adjust the feet to level the machine.
- A.1.3 Fasten the tables to the load and unload side of the machine. Most installations require fastening the turn-down lip of the dish tables to the side of the machine with flathead counter-sunk screws. The table design should provide horizontal clearance of 30" for servicing.

A.2 ELECTRICAL CONNECTIONS

- A.2.1 Connect electrical lines sized for the correct voltage, current and phase of the machine. These should agree with machine requirements indicated on the nameplate and labels in control panel.
- A.2.2 A single-point electrical connection is provided for the pumps, control circuit, and wash tank heater.
- A.2.3 If an electrical booster is provided connect the power directly to the booster. If the Insinger Self-Contained booster is provided the machine comes standard with a Single-Point Connection.

NOTE: In each case connections must be made to a circuit breaker or fused disconnect as provided by the end-user and required by local codes. A wiring diagram is supplied inside the control panel. Please return diagram when finished.

IMPORTANT: *As with any 3 phase system, an electrician should check all motors for proper phasing, i.e., Pump motors must be running in direction indicated by arrow on housing.*

A.3 MECHANICAL CONNECTIONS

- A.3.1 Connect 140DEGF water lines for tank fills/booster as tagged and noted on the installation drawings.
- A.3.2 If machine is provided with steam heat connect the steam lines and steam condensate lines as tagged and noted on installation drawings.
If machine is provided with gas heat, connect the gas lines for each tank.
- A.3.3 Connect the drain line.



**COMMANDER 18-3/CS-4
INSTALLATION INSTRUCTIONS
Section A**

A.3 MECHANICAL CONNECTIONS, cont'd

NOTE: Drain lines must be as specified on installation drawings. Drain line should be properly vented and should have fall of not less than 1/4" to the foot of proper flow. Some area plumbing codes require drains to flow into an open gap with an opening twice the diameter of the pipe. Check with your local plumbing codes for the type of drain connection required.

NOTE: All lines should be flushed prior to use to remove debris.

IMPORTANT: *Do not reduce the size of lines as specified in installation drawings. All lines are sized to facilitate necessary flows, pressures, etc.*

A.4 HVAC

A.4.1 Ventilation system should be sized to provide adequate ventilation per machine specs. Refer to spec sheet.

A.5 Chemicals

A.5.1 Upon completed installation of the dishwasher contact a local detergent/chemical supplier for the correct chemicals for your area.

A.5.2 Electrical connection points for the detergent dispenser and rinse injector are located inside the control panel. Refer to the wiring diagram for this machine for the proper connection points. Dispensers may be connected on either the primary voltage side of the machine or the 24VAC control voltage side.

IMPORTANT: *When connecting on the 24VAC control voltage side of the transformer, total KVA must not exceed .5KVA.*

A.5.3 The detergent density probe should be located in a convenient place in the wash tank.

A.6 Tabling

A.6.1 Load and unload tables should be pitched towards the machine to return excess water into the machine.



**COMMANDER 18-3/CS-4
OPERATION
Section B**

Insinger dishmachines are user-friendly, making them the easiest dishwashers on the market to operate and maintain.

By following the operation procedure and general cleaning procedures your Insinger dishwasher will give you years of trouble free service.

B.1 Operation Instructions

- B.1.1 Ensure drain overflow tube is in place Close the tank drain valve.
- B.1.2 Check for proper installation and cleanliness of all internal, removable components such as suction strainers, scrap screens, and spray manifolds.
- B.1.3 Ensure all water, steam, and gas lines are open. Ensure electrical circuits are on.
- B.1.4 Close machine doors.
- B.1.5 Move the power toggle switch to the "ON" position. The machine will fill the tank, run through a complete wash/rinse cycle and shut-off.
- B.1.6 When the tanks are full the tank heat will operate automatically. Proper tank heat temperature is 156DEGF minimum. Proper final rinse temperature is 180DEGF minimum.

IMPORTANT: *To ensure proper operation of the auto tank fill feature and the tank heaters level float(s) located in each tank MUST be cleaned daily.*

- B.1.7 Open doors.
- B.1.8 Insert a rack of soiled dishware in machine and lower doors. Machine will wash and rinse automatically. When the rinse indicator light goes off the machine cycle is complete.

NOTE: Overloading racks will minimize the proper cleaning of ware.

IMPORTANT: *Do not open the doors during the wash/rinse cycle as hot water is being sprayed. An interlock is provided to stop the wash/rinse cycle if the doors are open but the momentum of the spinning hubs will cause hot water to be sprayed.*

- B.1.9 Raise doors and remove rack of clean ware. For continuous operation repeat steps B.1.9 and B.1.10.

COMMANDER 18-3/CS-4
OPERATION
Section B

B.1 Operation Instructions, cont'd

- B.1.10 Upon completion of ware cleaning move the power toggle switch to the "OFF" position.
- B.1.11 Refer to the cleaning procedures for proper clean-up of the dishmachine.
- B.1.12 Report any unusual occurrences to qualified service personnel.

The following cleaning procedures should be done daily, at the end of the shift.

B.2 Cleaning Procedures, Daily

- B.2.1 Remove all internal removable parts including spray manifolds, scrap screens, drain overflow tubes, suction strainers and curtains.
- B.2.2 Remove the end caps from the spray manifolds and clean with the brush provided. Flush the manifolds.
- B.2.3 Flush scrap screens.
- B.2.4 Clean drain overflow tube.

Note: V-cup seal on the drain overflow tube may become gummed not allowing a proper seat of the overflow tube. This will cause the drain to leak water. Remove any build-up on the V-cup seal. When the seal becomes worn, replace.

- B.2.5 Clean suction strainers of build-up.

Note: Improper cleaning of suction strainers will cause the pumps to cavitate. This will cause poor washing results.

- B.2.6 Clean tank level float(s).

Important: Level floats must be cleaned daily. Build-up of grease and debris will cause faulty operation of tank fill and heating system.

- B.2.7 Final rinse nozzles should be cleaned of matter clogging the jet spray.
- B.2.8 Doors should be left open to allow drying of interior surfaces.

COMMANDER 18-3/CS-4 MAINTENANCE and REPAIR PROCEDURES Section A

Following is a basic guide for the repair and replacement of common dishwasher parts.

Refer to the Basic Service Guide for troubleshooting tips.

A.1 MAINTENANCE

A.1.1 Daily - Refer to the operation and cleaning instructions provided in this manual for daily cleaning procedures.

A.1.2 Weekly

A.1.2.1 The entire machine should be wiped down using an industrial grade stainless steel cleaner.

A.1.2.2 Under the supervision of your detergent supplier the machine interior must be properly de-limed.

NOTE: The water quality in some areas requires de-liming to be done more frequently. Contact your detergent supplier for recommended de-liming frequency.

A.1.3 Quarterly

A.1.3.1 Remove and clean the strainer screens on water and steam lines. If the screens cannot be cleaned, replace.

A.1.3.2 Inspect condition of solenoid valve seats and diaphragms. Replace where necessary.

A.1.3.3 Inspect drain O-Rings for leakage. Replace where necessary.

A.1.3.4 Check door spring tension and adjust where necessary.

A.1.3.5 Check wash and rinse hub bushing/bearing and replace where necessary.

A.2 MAINTENANCE PROCEDURES

A.2.1 Solenoid Valve Disassembly

A.2.1.1 Disconnect power supply to machine. Turn off Water supply.

A.2.1.2 Remove cap on top of coil. Remove coil.

A.2.1.3 Remove 4 hex bolts and lift bonnet from valve body. Note positioning of spring and plunger.

A.2.1.4 Remove main piston.

A.2.1.5 Inspect for dirt, wear or lime build-up. Clean or replace as required.

A.2.1.6 Reassemble in reverse of disassembly.

COMMANDER 18-3/CS-4
MAINTENANCE and REPAIR PROCEDURES
Section A

- A.2.2 Line Strainer Disassembly
 - A.2.2.1 Shut off water or steam supply.
 - A.2.2.2 Remove large hex nut on bottom of strainer body.
 - A.2.2.3 Remove strainer screen. Inspect and clean or replace as necessary.
 - A.2.2.4 Reassemble in reverse of disassembly. Water flow must be same direction as arrow on line strainer body. Use new gaskets to insure a tight seal.
- A.2.3 Pump Disassembly
 - A.2.3.1 Before disassembling pump ensure there are no obstructions in the pump intake. Remove and clean the suction strainer (inside tank).
 - A.2.3.2 IT IS NOT NECESSARY TO REMOVE THE PUMP HOUSING FROM THE MACHINE TO DISASSEMBLE THE PUMP.
 - A.2.3.3 Remove the pump motor and impeller adaptor by removing the 4 hex bolts attaching them to the pump housing.
 - A.2.3.4 Repair or replace the pump parts as required.
 - A.2.3.5 Reassemble in reverse of disassembly.
- A.2.4 Immersion Heater Replacement
 - A.2.4.1 The immersion heater MUST be completely submerged at all times. If this is not the case contact a qualified service technician. The heated surface should never be in contact with sludge.
 - A.2.4.2 Remove the housing covering the wiring terminations. Disconnect the immersion heater wires.
 - A.2.4.3 Remove the immersion heater by loosening and removing the large hex nut.
 - A.2.4.4 Install in reverse of removal.
NOTE: USE PLUMBERS PUTTY AS GASKETING AROUND THE IMMERSION HEATER TO INSURE NO LEAKS.
- A.2.5 Wash Tank Temperature Adjustment
 - A.2.5.1 A temperature control board is provided in the control panel for easy adjustment of tank temperature. Though tank temperature is adjusted during the machines factory test it is sometimes necessary to re-adjust the temperature at start-up.
 - A.2.5.2 Locate the temperature control board (P/N DE9-96). Use the control panel layout drawing located in Section 3, Electrical Schematic and Replacement Parts.

COMMANDER 18-3/CS-4
MAINTENANCE and REPAIR PROCEDURES
Section A

- A.2.5.3 Adjust the tank temperature to the desired temperature by turning the potentiometer located on the temperature control board. An arrow on the potentiometer indicates increase.
- A.2.5.4 If the temperature does not change refer to section A.2.6, Troubleshooting Tank Temperatures.
- A.2.6 Troubleshooting Tank Temperatures
 - A.2.6.1 Electric Heat
 - A.2.6.1.1 If temperature cannot be adjusted per section A.2.5 check the temperature control board P/N DE9-96 proper operation. If the temperature control board is faulty, replace.
 - A.2.6.1.2 Verify tank heat contactor is working correctly. If not, replace.
 - A.2.6.1.3 Verify all immersion heaters are working properly and not limed. If not, replace.
 - A.2.6.2 Steam Heat
 - A.2.6.2.1 See Section A.2.6.1.1.
 - A.2.6.2.2 Verify steam pressure per machine specifications.
 - A.2.6.2.3 Verify steam trap is not clogged. IF so, replace.
 - A.2.6.3 Gas Heat
 - A.2.6.3.1 See Section A.2.6.1.1.
 - A.2.6.3.2 Verify gas supply.
 - A.2.6.3.3 Verify pilot is lit. If not, light. If pilot does not stay lit, replace.
 - A.2.6.3.4 Verify gas solenoid is working correctly. If not, replace.
- A.2.7 Motor Overloads
 - A.2.7.1 All motors used on Insinger Machines are provided with motor overloads. Motor overloads are adjusted when the machines are factory tested. Should it be necessary to adjust the motor overloads in the field first verify the motor current draw for the voltage the machine is using.
 - A.2.7.2 Using the Control Panel Component Layout Dwg. located in Section 3 to identify the overload adjust by turning the dial to the appropriate AMP draw.



**COMMANDER 18-3/CS-4
MAINTENANCE and REPAIR PROCEDURES
Section A**

A.2.8 Level System

- A.2.8.1 The level control system consists of one level timer board (P/N DE7-32) and one level float (P/N DE5-60) per tank or two level floats for an electrically heated machine.
- A.2.8.2 The level timer and float will not allow the tank heat to energize without water in the tank.
- A.2.8.3 Should the tank heat energize with out water in the tank troubleshoot the system to find the problem.

IMPORTANT: LEVEL FLOATS MUST BE CLEANED DAILY TO ENSURE THE PROPER OPERATION OF THE LEVEL CONTROL SYSTEM.

A.2.9 Wash and Rinse Cycle

- A.2.9.1 The timing sequence consists of two timers. The Commander 18-3 and CS-4 use two, one minute timers (P/N DE7-27). The CA-3 and DA-3 use one, one minute timer (P/N DE7-27) and one, five minute timer (P/N DE7-28). Should either of these become defective, replace.

BASIC SERVICE GUIDE

SYMPTOM	POSSIBLE CAUSE	Solution
1. Machine will not operate	<ul style="list-style-type: none"> a. No Power b. Blown fuse or tripped breaker c. Motor overloads tripped 	<ul style="list-style-type: none"> a. Check power supply b. Replace fuse; reset breaker c. Reset overload
2. Tank will not hold water	<ul style="list-style-type: none"> a. Drain not closed b. Drain overflow not seated or installed c. Pump petcock opened 	<ul style="list-style-type: none"> a. Close drain b. Reseat or install drain overflow c. Replace V-seal
3. Tank fills beyond overflow	<ul style="list-style-type: none"> a. Obstruction in overflow tube or drain line 	<ul style="list-style-type: none"> a. Remove obstruction
4. Water leaks around door	<ul style="list-style-type: none"> a. Doors not seating b. Clogged spray pipe 	<ul style="list-style-type: none"> a. Reseat doors b. Clean spray pipe with brush provided
5. Weak or ineffective spray	<ul style="list-style-type: none"> a. Clogged spray pipe b. Manifolds not installed properly c. Obstruction in pump d. Pump rotation reversed e. Suction strainer clogged 	<ul style="list-style-type: none"> a. Clean spray pipe with brush pipe b. Ensure proper placement of upper and lower pipes c. Clear obstruction through pump inspection plate d. Arrow on pump housing indicates direction, correct electrically e. Clean suction strainer

BASIC SERVICE GUIDE

SYMPTOM	POSSIBLE CAUSE	Solution
6. Weak or ineffective final rinse spray	<ul style="list-style-type: none"> a. Lime deposits in spray nozzles b. Low water pressure c. Clogged line strainer d. Closed water supply valve 	<ul style="list-style-type: none"> a. Clean or replace nozzles b. Adjust to 20PSI c. Remove line strainer and clean d. Open ball valve
7. Water hammer	<ul style="list-style-type: none"> a. Excessive water line pressure 	<ul style="list-style-type: none"> a. Install water hammer limiting device
8. Machine vibrates or is noisy	<ul style="list-style-type: none"> a. Pump rotation reversed b. Pump bearings worn 	<ul style="list-style-type: none"> a. Arrow on pump housing indicates direction, correct electrically b. Replace pump bearings
9. Final rinse will not shut off	<ul style="list-style-type: none"> a. Final rinse solenoid valve clogged b. Diaphragm worn c. Solenoid valve still powered-up 	<ul style="list-style-type: none"> a. Disassemble valve and clean internal parts of scale or replace b. Replace with solenoid valve repair kit c. Check final rinse actuating circuit for proper operation

BASIC SERVICE GUIDE

SYMPTOM	POSSIBLE CAUSE	Solution
10. Tank not filling/tank heat coming on with no water in tank	<ul style="list-style-type: none"> a. Level probes dirty b. Level control system not working 	<ul style="list-style-type: none"> a. Clean level probe with Scotch-Brite or equivalent - two probes per tank b. Troubleshoot level control circuit
11. Tank temperature too low/high	<ul style="list-style-type: none"> a. Thermostat not adjusted b. Heat circuitry not working c. Electric heat, power turned off d. Electric heat, immersion heaters limed e. Steam heat, steam turned off f. Steam heat, not enough steam g. Steam heat, condensate traps clogged h. Gas heat, gas turned off i. Gas heat, pilot not lit 	<ul style="list-style-type: none"> a. Adjust thermostat located in control panel b. Troubleshoot circuitry c. Turn power on d. De-lime machine e. Turn steam on f. Adjust steam pressure per machine spec's g. Clean or replace condensate traps h. Turn on gas i. Re-light pilot

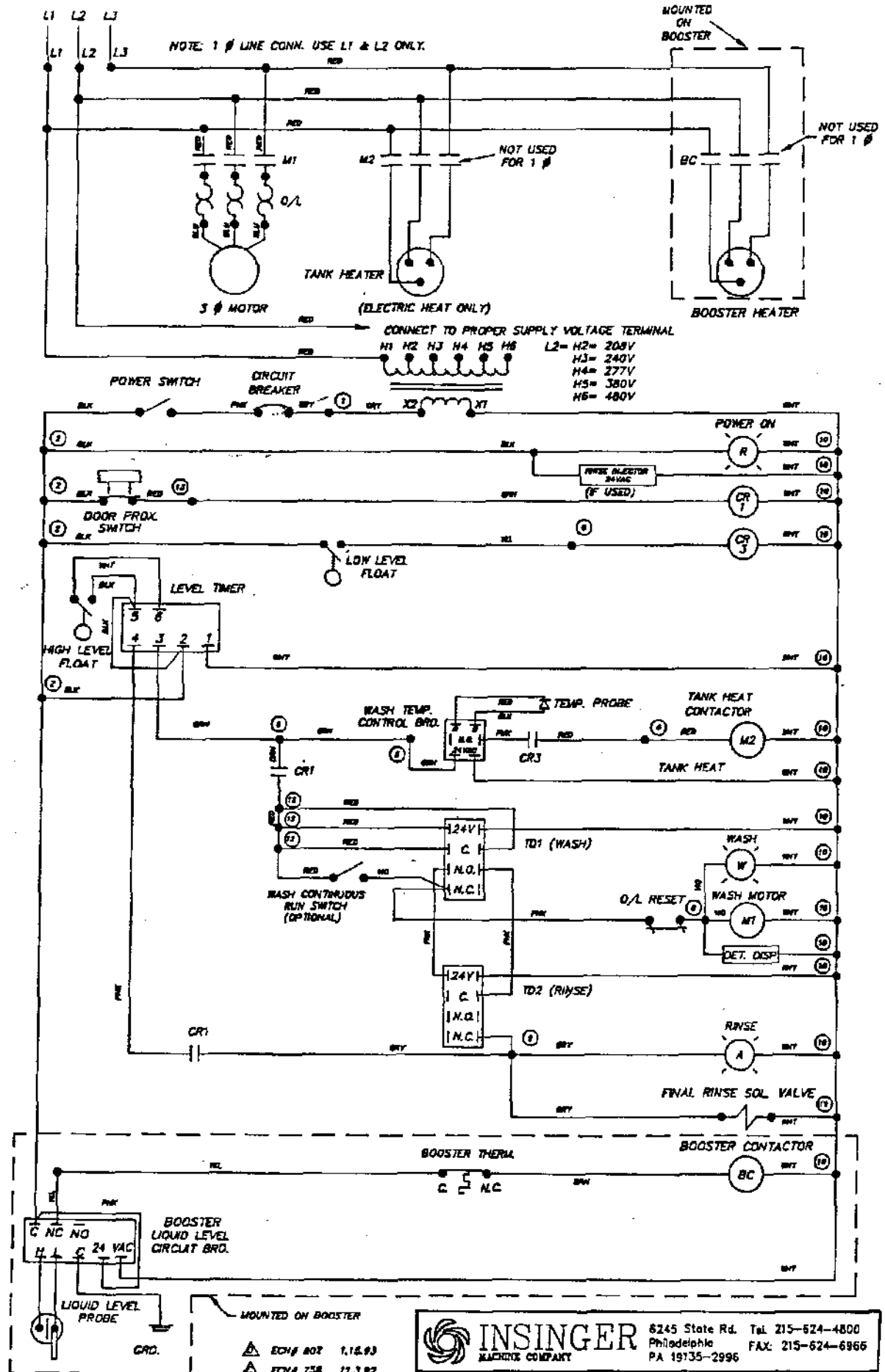

FILE: \MFE\DOOR030

- ▲ ECH# 802 1.18.93
- ▲ ECH# 758 11.3.92
- ▲ ECH# 722 8.18.92
- ▲ ECH# 719 8.14.92

 INSINGER MACHINE COMPANY	6245 State Rd. Tel: 215-624-4800
	Philadelphia PA 19135-2996 FAX: 215-624-6866
MACHINE: DOOR TYPE MACHINE-ELEC. W/ S.C.R.	DWG. NO.
DRAWN: RAF 08.05.88	WDOOR030 D
APPROVED: WJM 08.05.88	

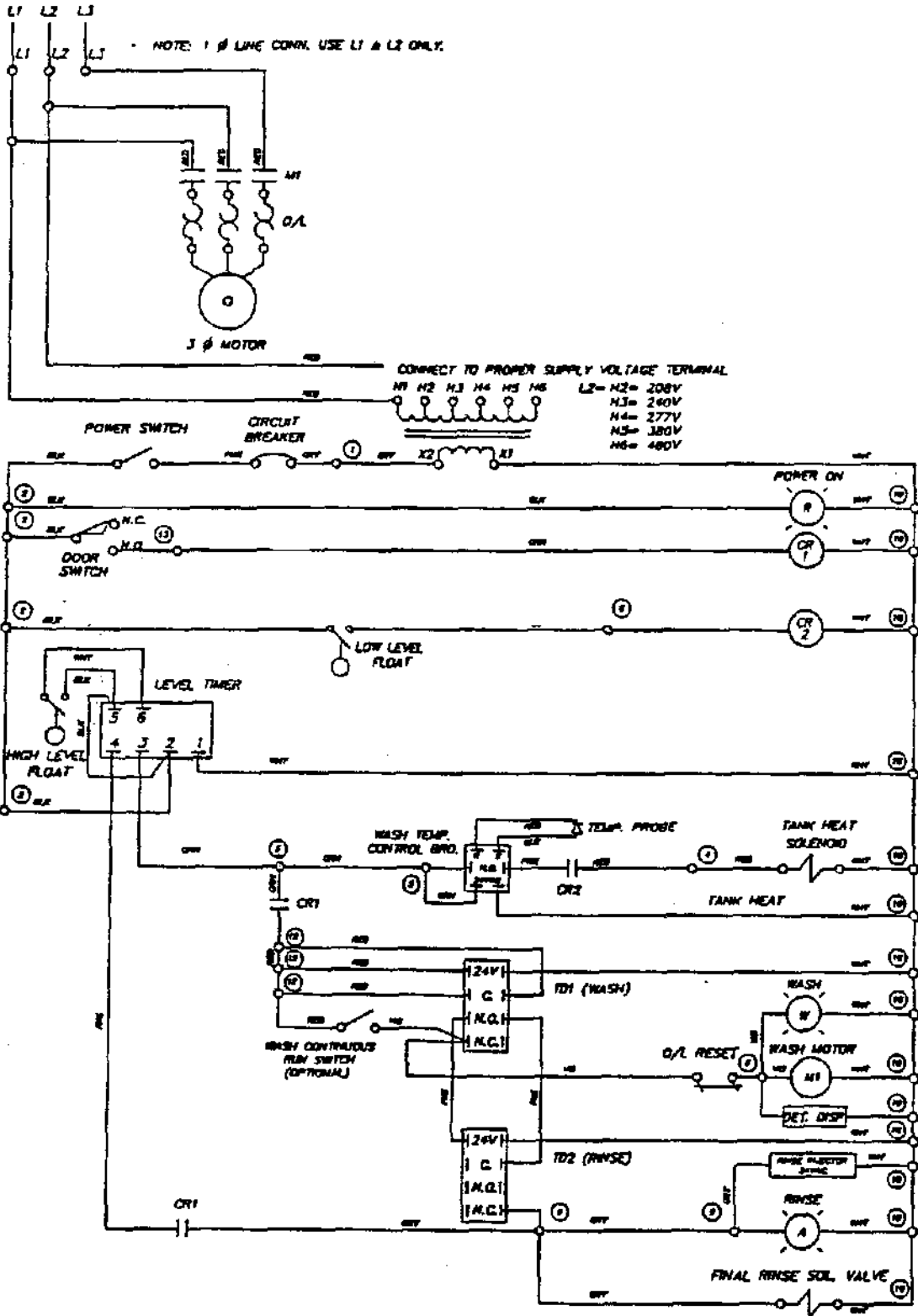

FILE: \HWME\DOOR090

EDM 758 11.3.02

	INSINGER WACORP COMPANY	6245 State Rd. Tel. 215-624-4800 Philadelphia PA 19135-2996 FAX: 215-624-5966
	MACHINE: DOOR TYPE MACHINE - GAS DRAWN: RAF 08.05.88 APPROVED: MAM 08.05.88	DWG. NO. WDOOR090 B

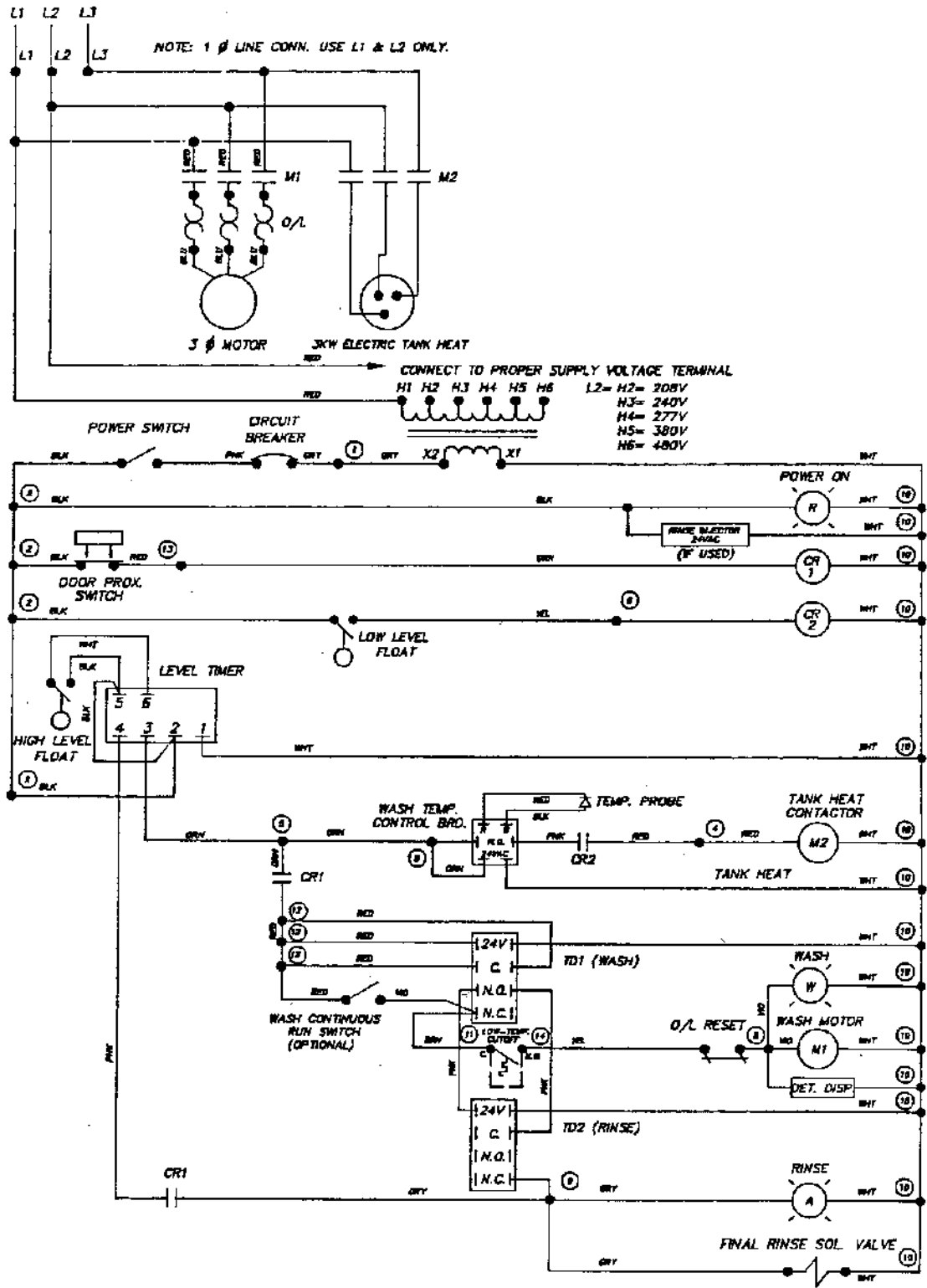

NOTE:

1. IF NO LOW-TEMPERATURE CUTOFF IS SPECIFIED, A JUMPER IS PROVIDED BETWEEN TERMINALS 11 & 14.

FILE: \WRE\DOOR020
 ECH# 802 11.3.93
 ECH# 758 11.3.92

	INSINGER MACHINE COMPANY	6245 State Rd. Tel: 215-624-4800 Philadelphia PA 19135-2996 FAX: 215-624-6986
	MACHINE: DOOR TYPE MACHINE - ELECTRIC DRAWN: RAF 08.05.88 APPROVED: M.J.M 08.05.88	DWG. NO. WDOOR020

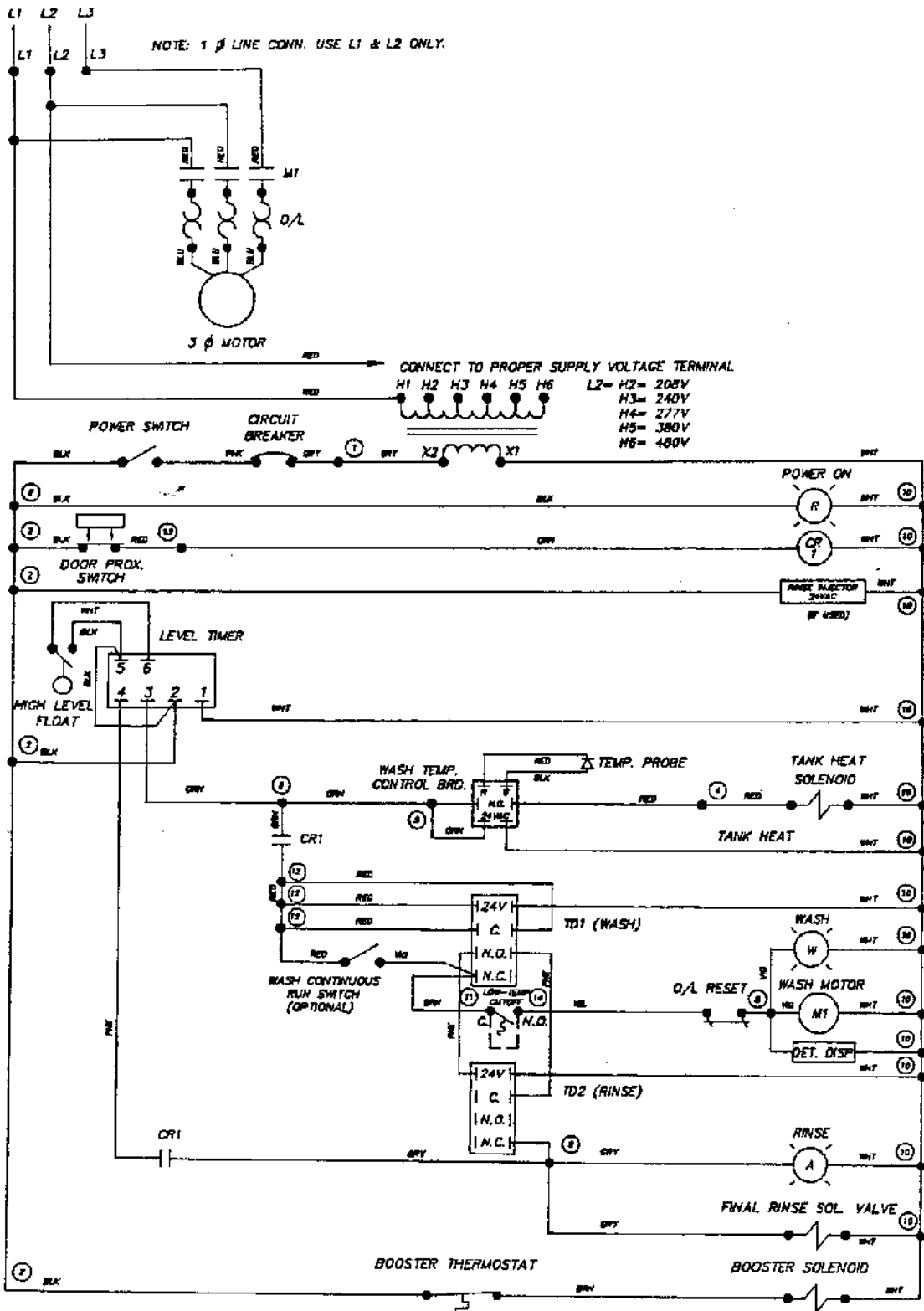

NOTE:

1. IF NO LOW-TEMPERATURE CUTOFF IS SPECIFIED,
 A JUMPER IS PROVIDED BETWEEN TERMINALS 11 & 14.

FILE: \NRF\DOOR010

△	EDN# 802	1.15.93
△	EDN# 758	11.3.92
△	EDN# 733	10.2.92
△	EDN# 722	9.18.92
△	EDN# 719	9.14.92

		6245 State Rd. Tel. 215-624-4800 Philadelphia FAX: 215-624-6966 PA 19135-2996	
		MACHINE: DOOR TYPE MACHINE - STEAM	DWG. NO.
DRAWN: RAF	08.05.88	WDOOR010 E	
APPROVED: M.J.M.	08.05.88		

PARTS LIST-CONTROL BOX COMPONENTS

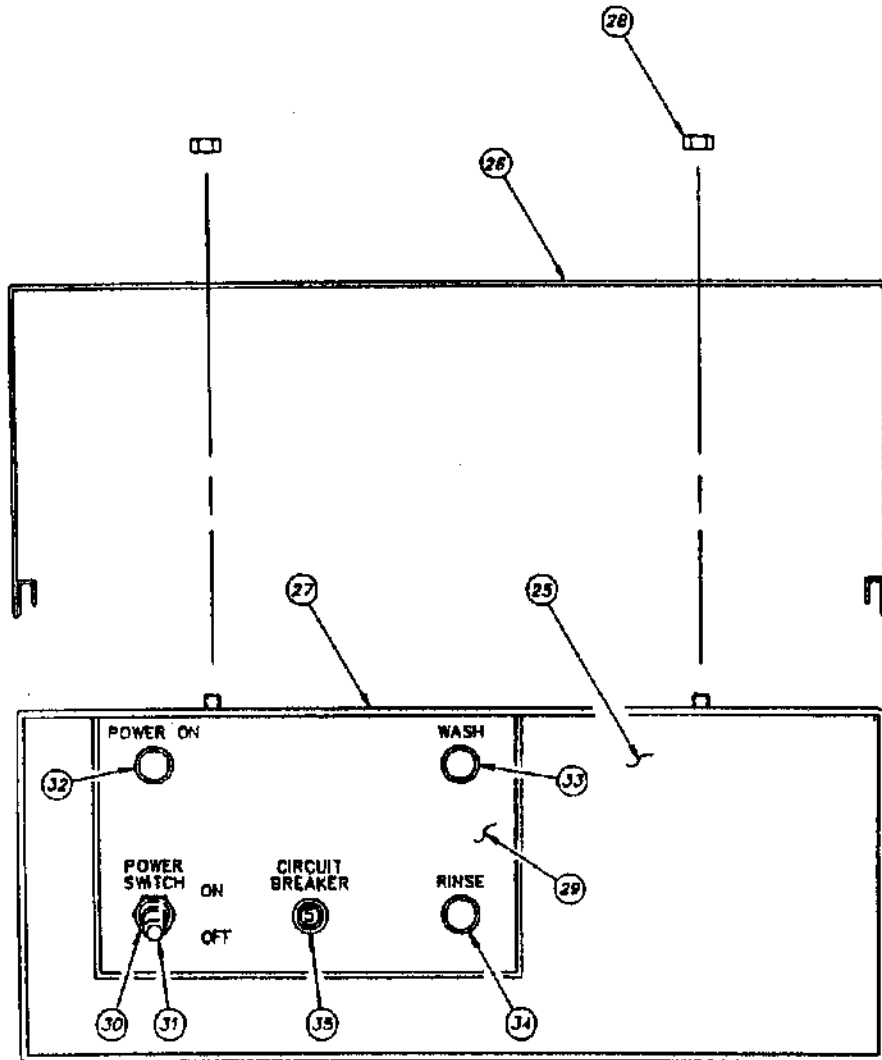

ITEM	DESCRIPTION	PART NO.	QTY.
25	CONTROL BOX	DJ-704	1
26	CONTROL BOX COVER	DJ-713	1
27	GASKET	9007-001	1
28	SEAL NUT	DJ12C-EF-5	1
29	LEGEND DECAL	SK-2308	1
30	SWITCH ASSEMBLY	DE5-8	1
31	BOOT, SWITCH	DE9-13	1
32	PILOT LIGHT (RED)	DE9-107	1
33	PILOT LIGHT (WHITE)	DE9-108	1
34	PILOT LIGHT (AMBER)	DE9-109	1
35	CIRCUIT BREAKER (5A)	DE9-43	1

NOT SHOWN:

ITEM	DESCRIPTION	PART NO.
36	TANK IMMERSION HEATER (3KW)	
	480VAC-3PH	DE13-SC73
	380VAC-3PH	DE13-SC53
	240VAC-3PH	DE13-SC43
	240VAC-1PH	DE13-SC41
	220VAC-3PH	DE13-SC33
	220VAC-1PH	DE13-SC31
	208VAC-3PH	DE13-SC23
	208VAC-1PH	DE13-SC21

FILE: \SKETCH\SKJ4902

△ ECH/ 758 11.6.92

MAM 8.13.92

SK-3490

PG. 2 OF 2

 INSINGER MACHINE COMPANY	6245 State Rd. Tel. 215-624-4800
	Philadelphia FAX: 215-624-6966
	PA 19135-2986

PARIS LIST-CONTROL BOX COMPONENTS

ITEM	DESCRIPTION	PART NO.	QTY.
1	CONTROL COMPONENT PLATE	DE10-6	1
2	TRANSFORMER	DE6-6	1
3	OVERLOAD ALL VOLTAGES		
	480V-3PH-60HZ 1.8A	DE2-32	
	380V-3PH-50HZ 2.0A	DE2-28	
	240V-3PH-60HZ 3.6A	DE2-30	
	240V-1PH-60HZ 8.0A	DE2-34	
	220V-3PH-50HZ 4.3A	DE2-41	
	220V-1PH-50HZ 9.0A	DE2-34	
	208V-3PH-60HZ 3.6A	DE2-30	
	208V-1PH-60HZ 10.0A	DE2-34	
4	CONTACTOR (PUMP MOTORS)	DE1-66	1
5	CONTACTOR (ELEC. TANK HEAT ONLY)	DE1-66	1
6	AUXILIARY CONTACT	DE1-62	1
7	RELAY BASE	DE2-37	AR
8	RELAY	DE2-38	AR
9	RELAY HOLD-DOWN SPRING	DE3-43	AR
10	DIN RAIL	DE9-844	1
11	TIME DELAY (WASH, RINSE)	DE7-27	2
12	TERMINAL END COVER PLATE	DE3-40	2
13	TERMINAL SECTION	DE3-39	14
14	TERMINAL BLOCK ASS'Y. (UP TO 300V.)		
15	TERMINAL END CLAMP (300V. - 600V.)	DE3-9	1
16	DIN RAIL (TERMINAL STRIP)	DE3-41	2
17	CIRCUIT BOARD (TEMPERATURE CONTROL)	DE9-42B	1
18	1/4 INTERNAL TOOTH LOCK WASHER	DE9-96	1
19	1/4-20 HEX NUT	DJ12C-G2	1
20	1/4-20 X 1/2 LG. WELD STUD	DJ09C-GC-4G	1
21	TIMER, LEVEL	DE7-31	1

USED ON: COMMANDER 1B-3 S/N 927580 & GREATER
COMMANDER 1B-4
CS-4

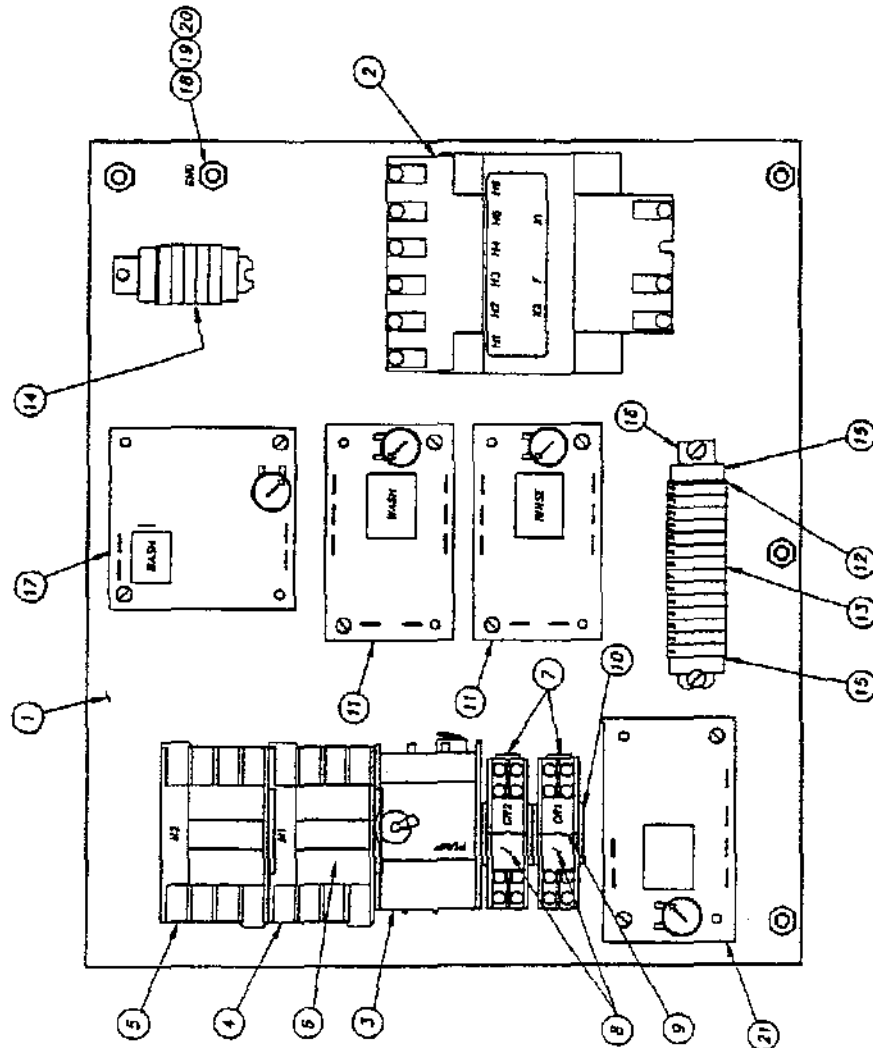

MANH 9.13.92

SK-3490

PG. 1 OF 2



INSINGER
MACHINE COMPANY

6245 State Rd. Tel. 215-624-4800
Philadelphia FAX: 215-624-8866
PA 19135-2986



EDW# 755 11.6.92

FILE: \SKETCH\SA34901

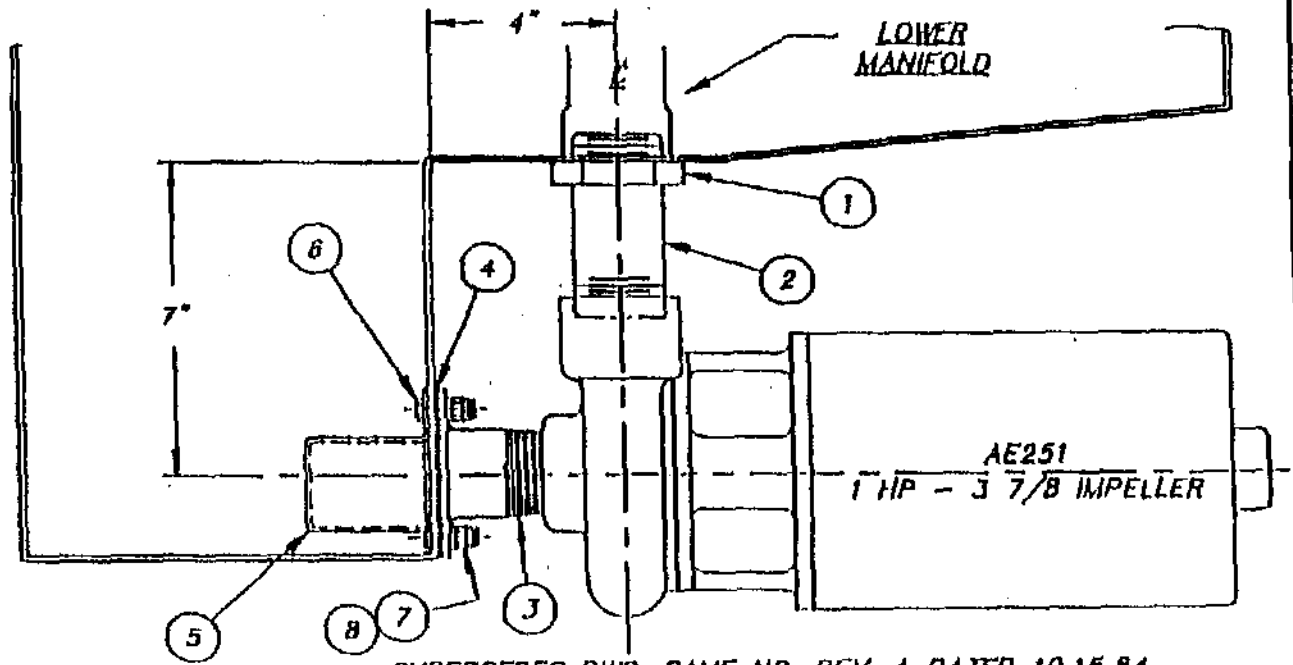
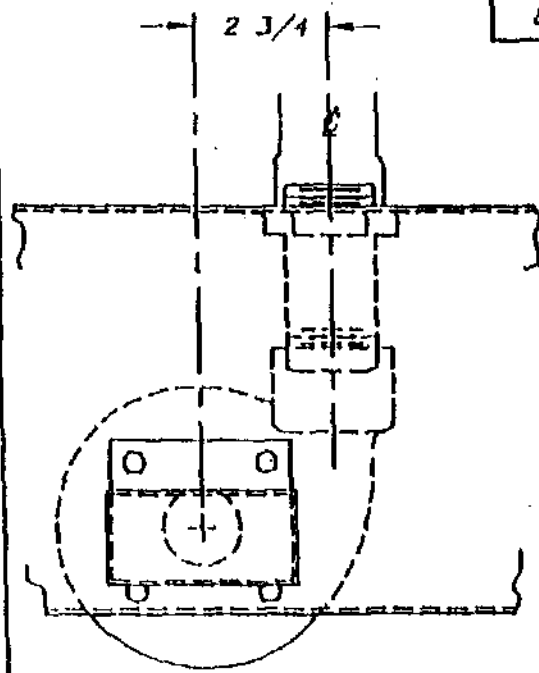
ITEM	PART NO.	DESCRIPTION	QTY.
1	D326F-111	LOCKNUT 1 1/2 IPS	1
2	DJ14C-HL-32	NIPPLE 1 1/2 IPS x 4" LG. LOE	1
3	1089-180	SUCT. NIPPLE & FLG. WELDMENT	1
4	D-514	GASKET	1
5	1089-20	COVER	1
6	DJ09C-JC-BA	HEX HD. SCREW 3/8-16 x 1" LG.	4
7	D313A-J1	COPPER WASHER 3/8	4
8	D312C-JC-5	LOCKNUT 3/8-16	1



SUPERSEDES DWG. SAME NO. REV. A DATED 10.15.84

-  ECN# 576 9.03.91
-  ECN# 319 9.05.89

TOLERANCES FRACTIONS ±1/64 DECIMALS .XXX ± .005 .XX ± .01 ANGULAR ±1/2 UNLESS OTHERWISE SPECIFIED	TITLE PUMP, MOTOR & SUCTION ASSEMBLY	NEXT ASSY REQ. 1	DWG. NO. 1089-19
	MAT'L. AS NOTED	SCALE 1:4	USED ON 18-JCS-4 (ALL)
		Philadelphia, PA 19135 (215) 624-4800 FAX (215) 624-6086	DRWN/DATE RFN 9.03.91

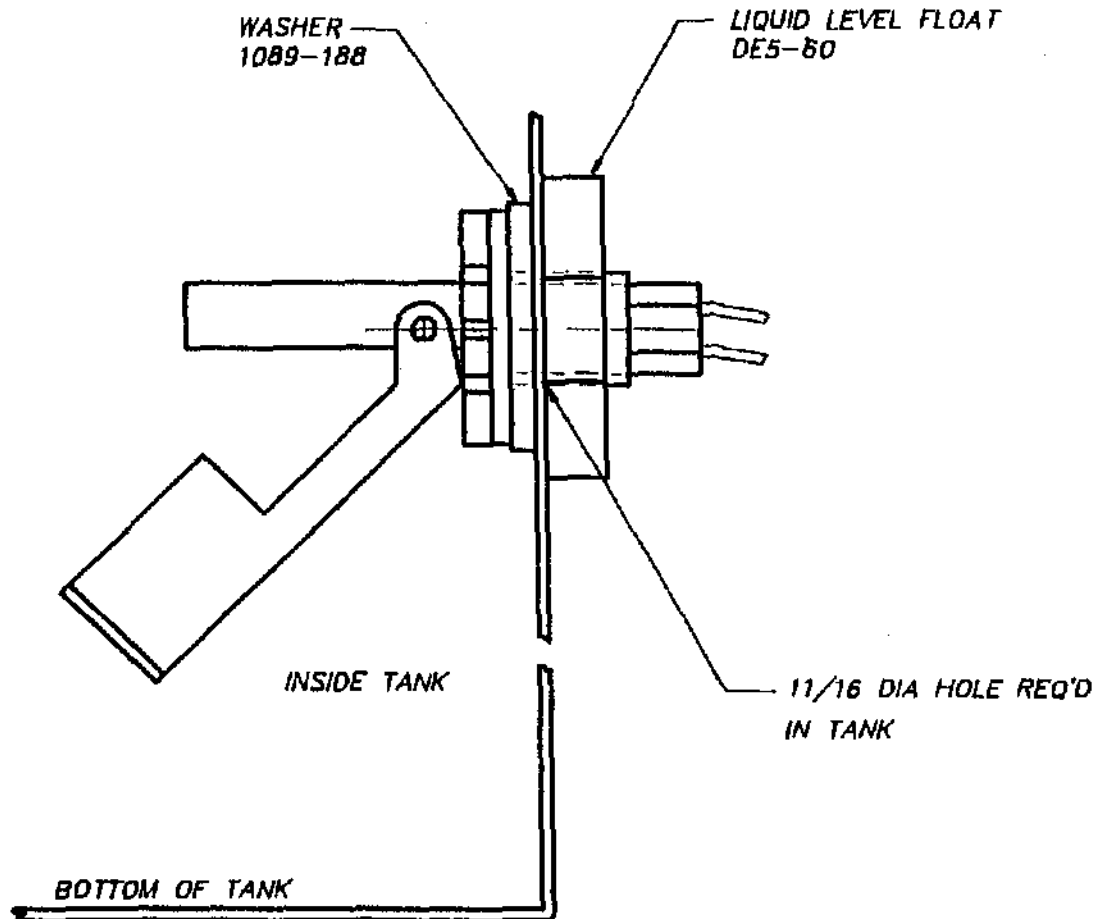

NOTE:
INSTALL LIQUID LEVEL FLOAT
IN POSITION SHOWN.

			TOLERANCES	TITLE	LIQUID LEVEL FLOAT	NEXT ASSY	DWG. NO.
			FRACTIONS $\pm 1/64$	TYPICAL INSTALLATION		REQ'D	1089-189
			DECIMALS	MATL		SCALE	USED ON
			.XXX $\pm .005$	AS NOTED		FULL	ALL MODELS
			.XX $\pm .01$	 Insinger Machine Company		Philadelphia, PA 19135 (215) 624-4800 FAX (215) 624-6866	
			ANGLES $\pm 1/2^\circ$				
REV	ECN NO	DATE	UNLESS OTHERWISE SPECIFIED			PG	
FILE: PARTS\1089-189						7.2.02	

ITEM	PART NO.	VOLTAGE/PHASE
J	DEJ-BG2J	115 KW / 208V-3PH
	DEJ-BG3J	115 KW / 220V-3PH
	DEJ-BG4J	115 KW / 240V-3PH
	DEJ-BG5J	115 KW / 280V-3PH
	DEJ-BG6J	115 KW / 440V-3PH
	DEJ-BG7J	115 KW / 480V-3PH

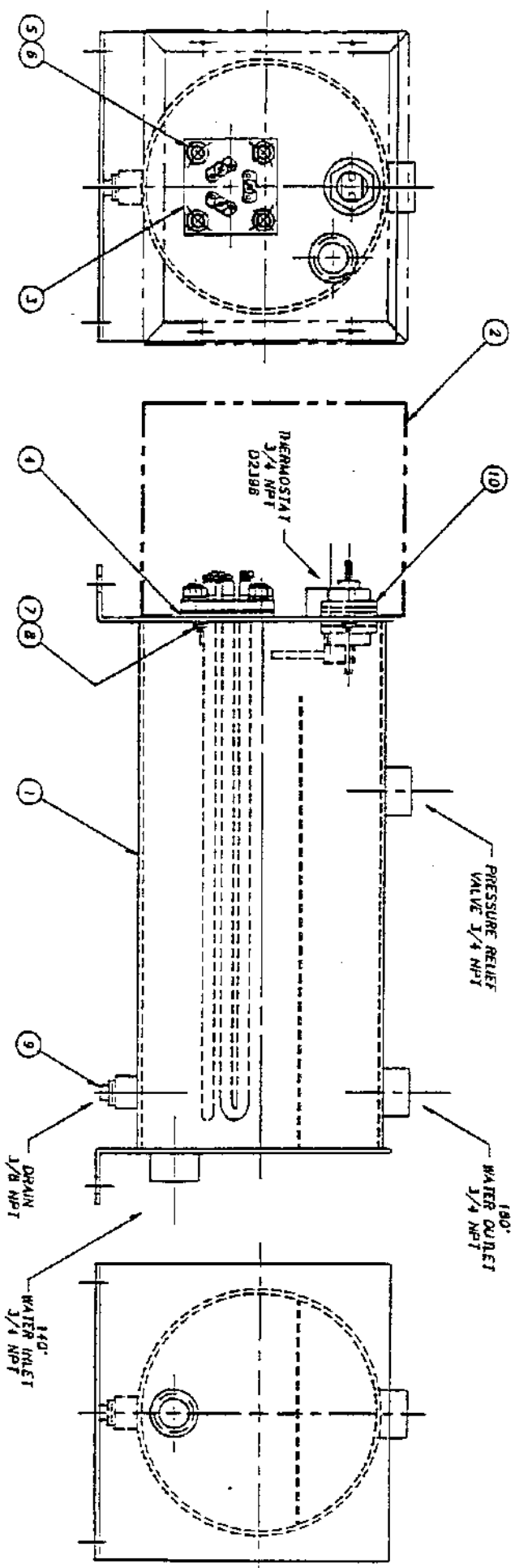

NO.	PART NO.	DESCRIPTION	QTY.
1	1192-2	MOTOR, BOOSTER	1
2	1192-7	COVER, SATELLITE CONTROL BOX	1
3	SEE TABLE	HEATER, IMMERSION	1
4	1192-8	GASKET, HEATER	1
5	D112C-JC-2	NUT, HEX	1/8-18 UNC-2B
6	D112C-2J	LOCKWASHER	1/8
7	D112C-EF-2	NUT, HEX	#10-32 UNF-2B
8	D112C-2E	LOCKWASHER	#10
9	D128C-C2	PLUG, PIPE	1/8 NPT
10	D2170-J1	ASSTY. LIQUID LEVEL PROBE	1

DIMENSIONS		MATERIAL		FINISH		WEIGHT	
FRONT	11 1/2"	STAINLESS STEEL	304	PAINT	BLACK	NET WT.	11.28 LB
HEIGHT	11 1/2"	WARRANTY	1 YEAR	FINISH	POUR	GROSS WT.	11.28 LB
DEPTH	11 1/2"	ASSEMBLY	1	WEIGHT	11.28 LB		

SELF CONTAINED BOOSTER ASSEMBLY

INSINGER MACHINE CO.
 (216) 624-1800 FAX (216) 621-6066
 11-28-90

REV. 1192-1
 EQM 517 12.21.90

USED ON:

50-20N2-NSU

50-20N2-NSU (CORNER MODEL)

1B-3, 1B-3C

CS-4, CS-4C

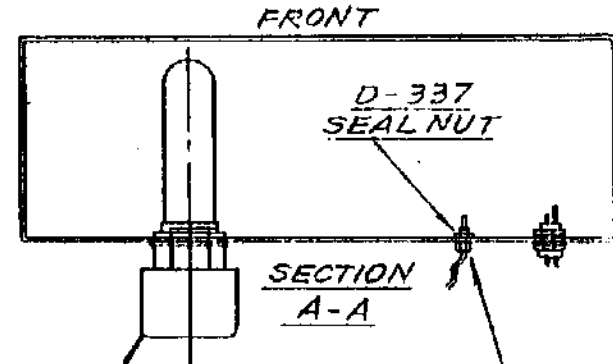

D2466-3.0XC
ELECTRIC
HTR. 3KW

D-2599
DIODE
JUNCTION

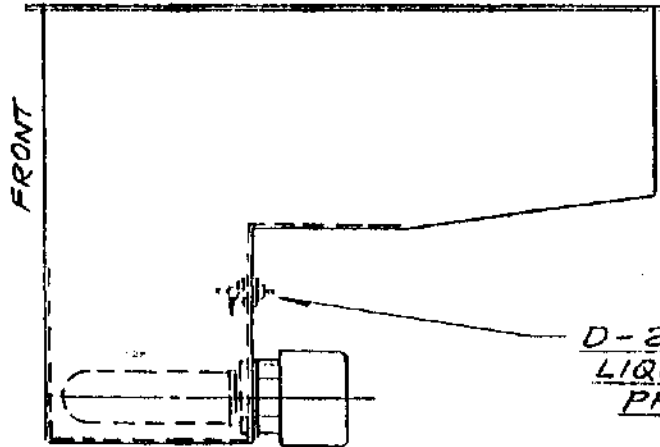

D-2470-31
LIQUID LEVEL
PROBE

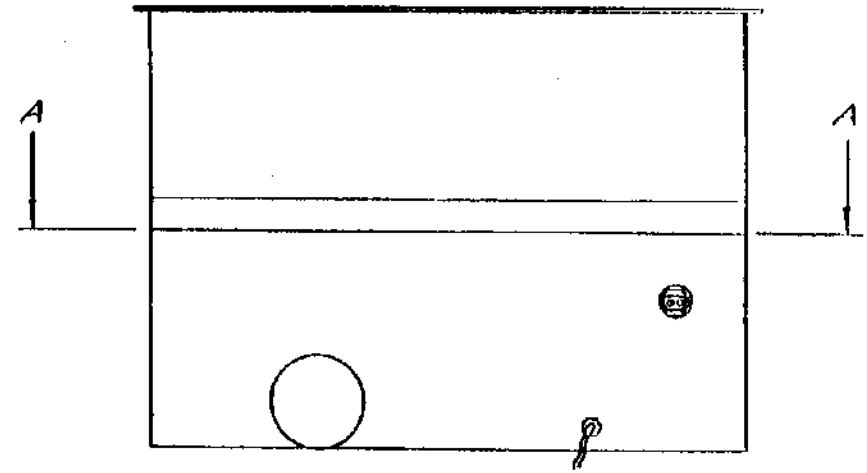

REAR
VIEW

TOLERANCES FRACTIONS ± 1/64 DECIMAL ± .005 ANGULAR ± 1/2° UNLESS OTHERWISE SPECIFIED	TITLE	PATT. NO.	DWG NO
	<u>ELEC. HTR., DIODE</u>	REQ.	<u>SK-2828</u>
	<u>JCT. & LIQ. LEVEL PROBE</u>	SCALE <u>1/8</u>	USED ON
	MATL. <u>NOTED</u>		<u>NOTED</u>
	INSINGER MACHINE CO. PHILA., PA. 19135 (215) 624-4800		<u>RF 5 1.87</u>

NO.	DESCRIPTION	PART NO.	QTY
1	BOOSTER ASSEMBLY	29-12	1
2	RELIEF VALVE	30PL-1600078	1
3	BALL VALVE 1/2 IPS	3-2339	1
4	CLOSE NIPPLE 1/2 IPS	10314A-0CL	2
5	BRACKET	10WG-382-49	1
6	BRESS. REC. & STRAINER 1/2 IPS	3-2306A	1
7	TEE 1/2 IPS	D320A-01	1
8	REDUCED 1/2 NIPS - 1/4 NIPS	D322A-02-B1	1
9	PIPE PLUG 1/2 IPS	D328A-0-A	1
10	ADAPTER 1/2 NIPS - 1/2 C	D317A-02-03	1
11	COPPER TUBING 1/2 CTS - 6 1/2 LG.	D207A-8A-2G1	1
12	90° ELBOW 1/2 C	D316A-03	1
13	COPPER TUBING 1/2 CTS - 7 1/2 LG.	D207A-8A-30	1
14	90° ELBOW 1/2 NIPS - 1/2 C	D316A-01-03	1
15	90° STREET ELL 1/2 IPS	D316A-01-02	1
16	UNION 1/2 C	D318A-03	1
17	COPPER TUBING 1/2 CTS - 22 1/2 LG.	D207A-8A-00	1
18	COPPER TUBING 1/2 CTS - 40 1/2 LG.	D207A-8A-08	1
19	COPPER TUBING 1/2 CTS - 3' LG.	D207A-8A-12	1
20	90° ELL 1/2 NIPS - 1/2 C	D316A-02-01	1
21	COPPER TUBING 1/2 CTS - 6 1/2 LG.	D207A-8A-27	1
22	90° ELL 1/2 C	D316A-03	2
23	90° STREET ELL 1/2 NIPS - 1/2 NIPS	D316A-01-02	1
24	90° ELL 1/2 NIPS - 1/2 C	D316A-01-03	1

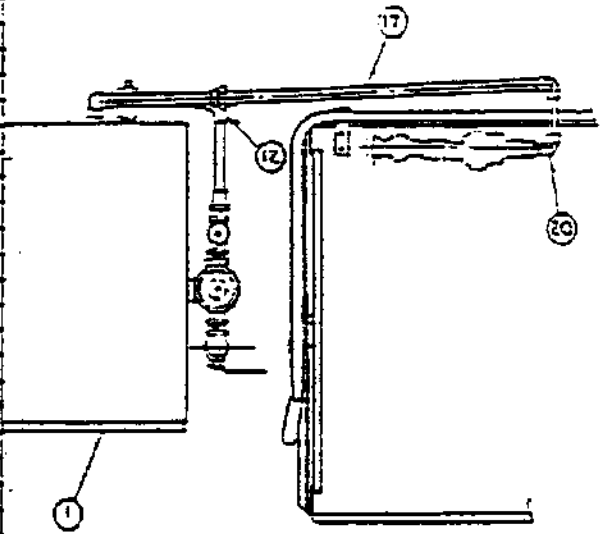

USED ON:
 10-3 18-1C
 30-20N2-NSU

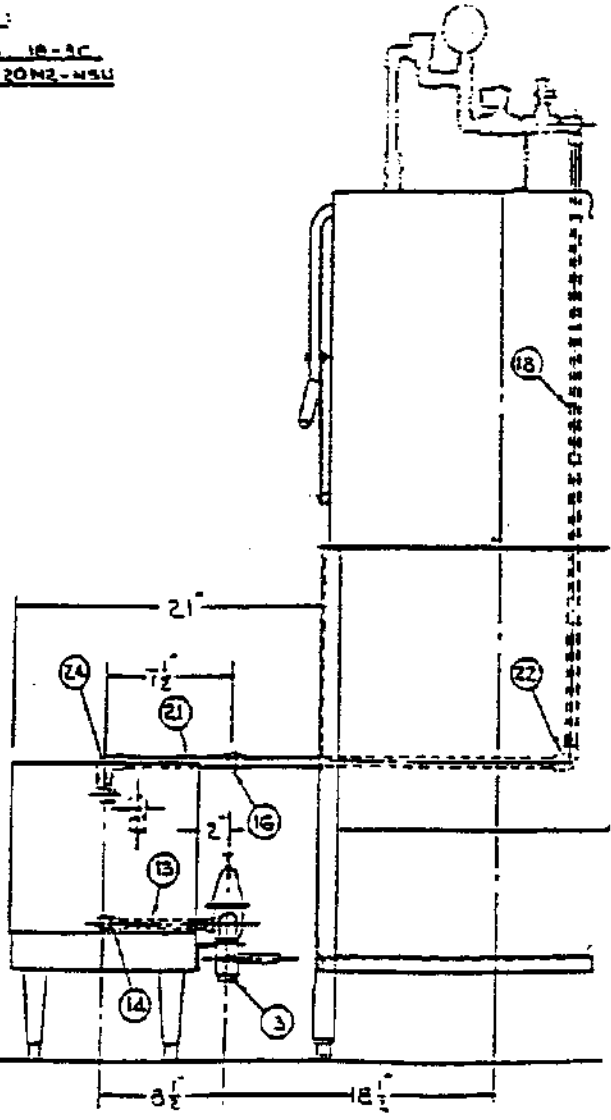
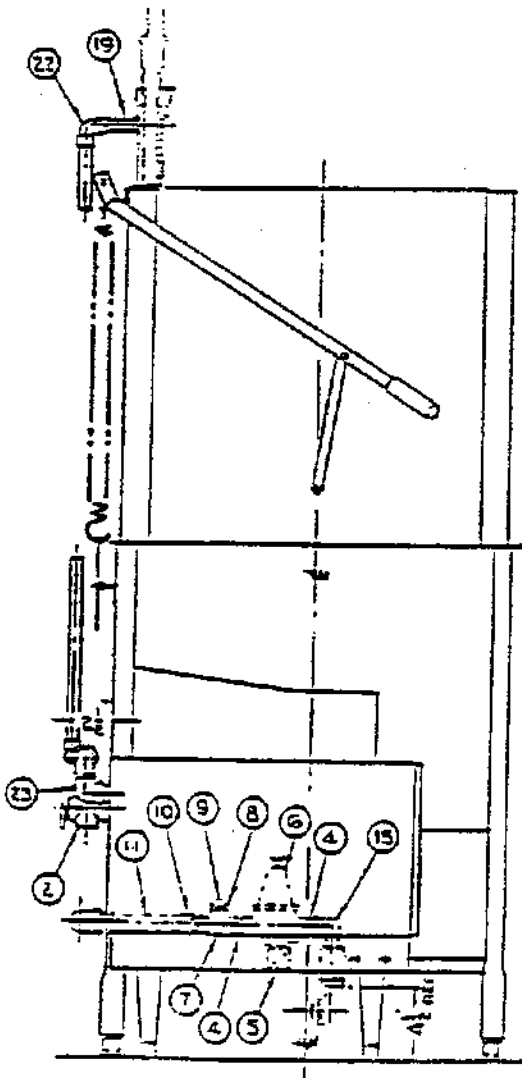

SUPPESSES DWGS 1089-119
 DATED 10-23-85, 1089-127 DATED
 2-2-87, 1089-138 DATED 3-2-87

DESIGNER	TITLE	PART NO.	DWG. NO.
INSINGER	BOOSTER ASSEMBLY	29-12	1089-87
DATE	SCALE	REV.	USED ON
10-23-85	3/16"	1	NOTED
INSINGER MACHINE CO.			
PHILA. PA. 19122	3-23-86		

1089-17

NO.	DESCRIPTION	PART NO.	QTY.
1	BOOSTER ASSEMBLY	721-30	1
2	90° UNION ELBOW 1/2" C	D319F-D3-D3	1
3	90° UNION ELBOW 1/2" C x 1/2" MIP S	D319F-D3-D2	1
4	90° ELBOW 1/2" C	D316F-D3-D3	2
5	ADAPTER 1/2" C x 1/2" MIP S	D317F-D3-D2	1
6	COPPER TUBING 1/2" CTS x 3" LG.	D207A-B4-12	1
7	COPPER TUBING 1/2" CTS x 43" LG.	D207A-B4-172	1
8	COPPER TUBING 1/2" CTS x 21 1/2" LG.	D207A-B4-86	1
9	COPPER TUBING 1/2" CTS x 18" LG.	D207A-B4-72	1
10	TEE 3/4" MIP S x 1/2" MIP S x 3/4" MIP S	D320F-D1E1E1	1
11	PRESSURE RELIEF VALVE 3/4" MIP S	D2507	1
12	COPPER PIPE 3/4" IPS x 4" LG.	D314A-ES-32	1

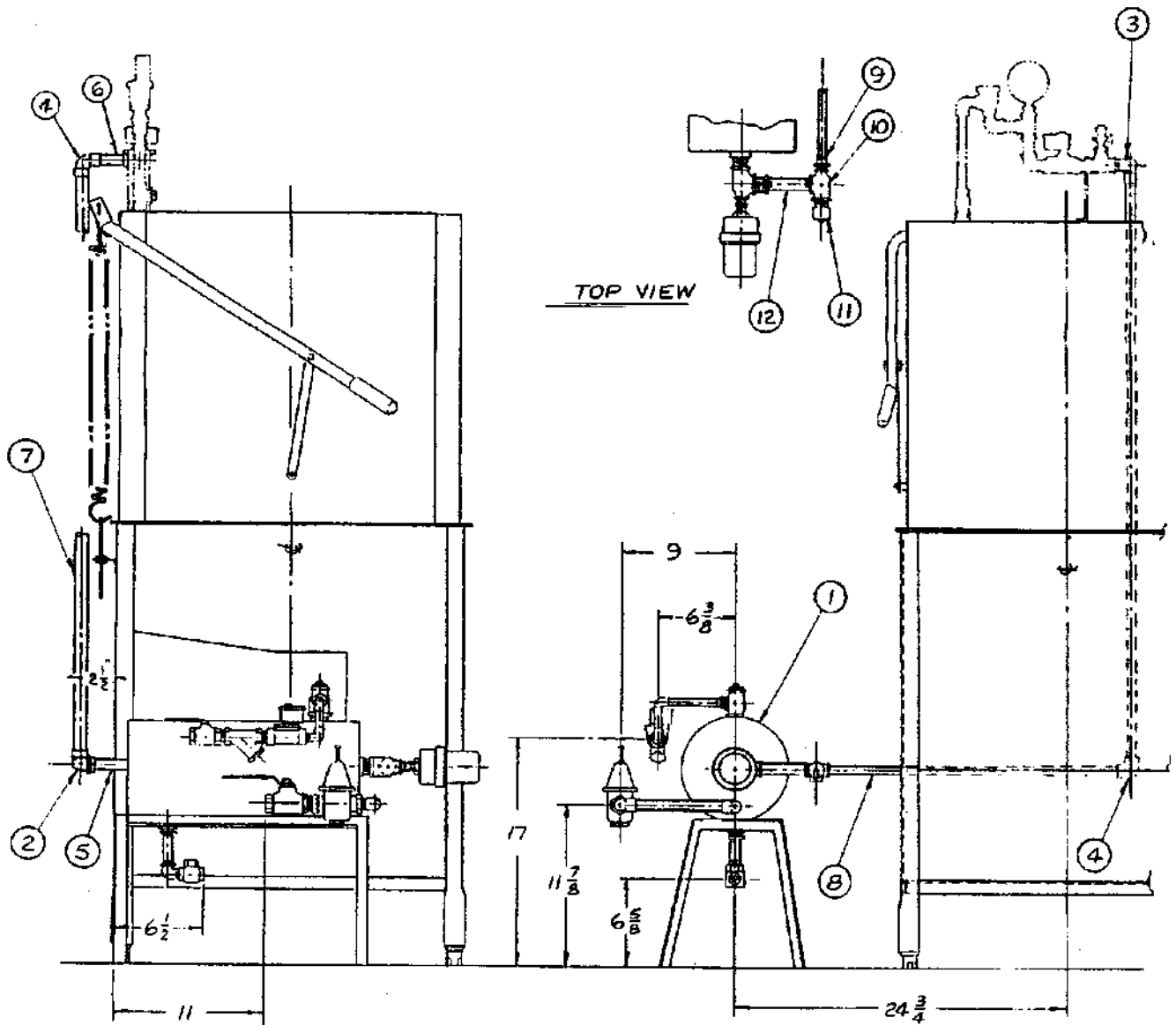

TOLERANCES FRACTIONS ± 1/64 DECIMAL ± .005 ANGULAR ± 1/2° UNLESS OTHERWISE SPECIFIED	TITLE	PART NO.	DWG NO.
	SIDE MOUNT STEAM BOOSTER TO FINAL RINSE MOUNTING ASS'Y.	RED 1	1089-179
	MATL.	SCALE 1/8"	USED ON 18-3
	NOTED		50-2002-ASU 12/2/21
INSINGER MACHINE CO. PHILA. PA. 19135 (215) 624-4800			6-5-90

S.K. 2836
PG. 1 OF 2

INSINGER MACHINE CO.
PHILA., PA. 19125 1251 27-1800

68-1-2-57

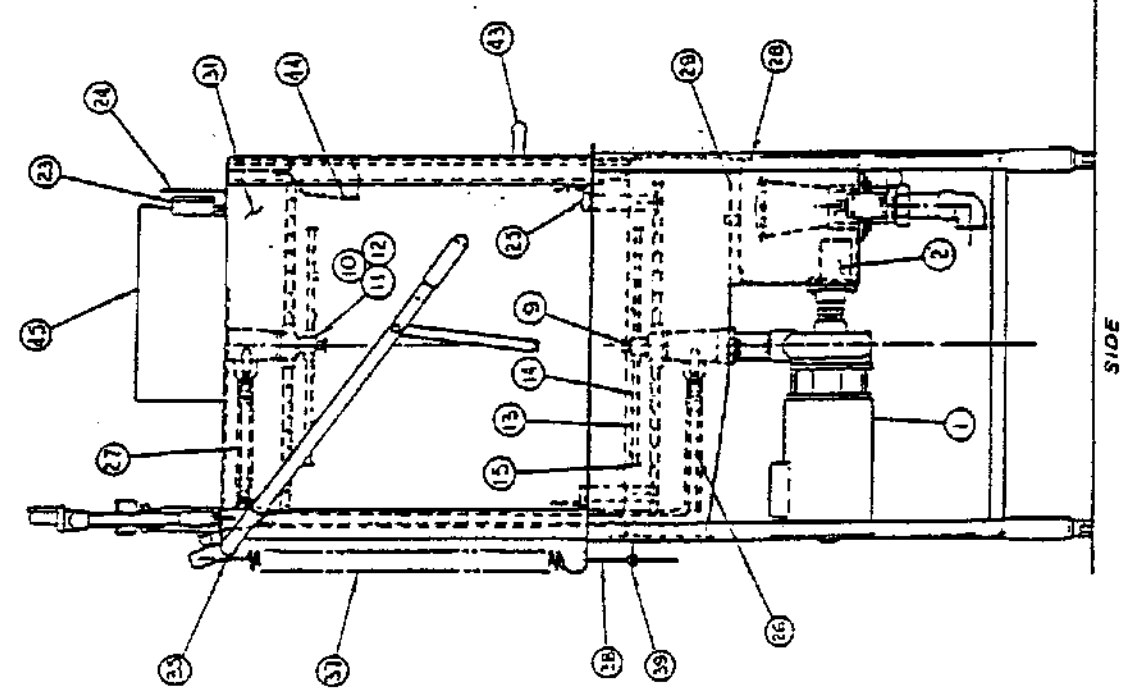
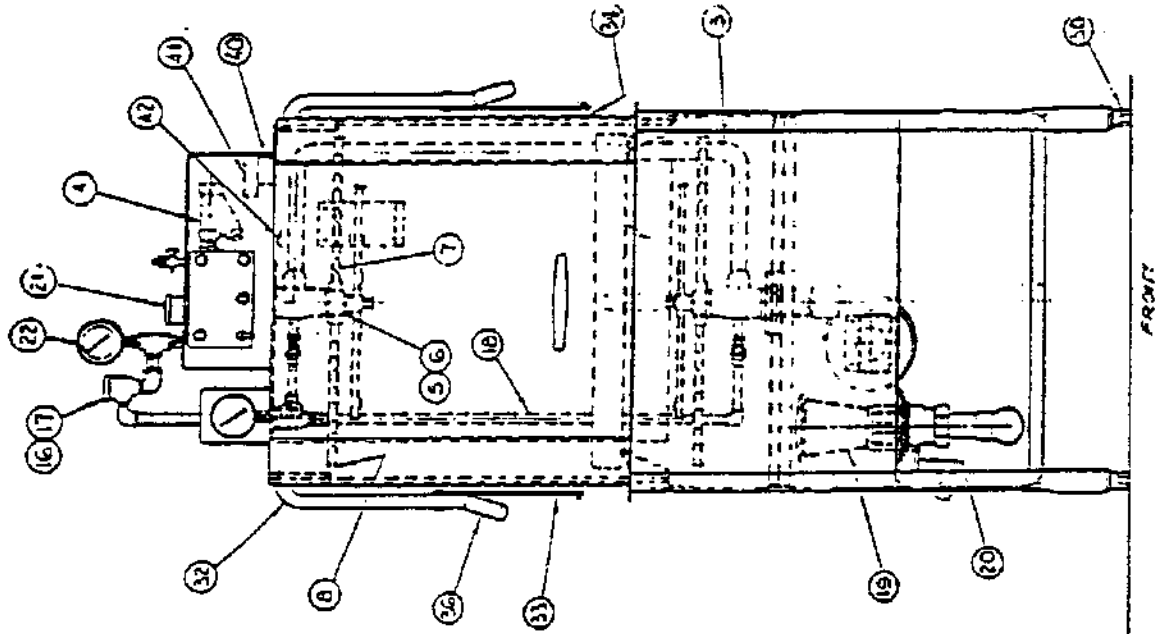

PARTS LIST - COMMANDER 18-J

<u>ITEM</u>	<u>PART NO.</u>	<u>DESCRIPTION</u>	<u>REQ.</u>
1	D-2465	Pump & Motor Ass'y. (1 HP)*	1
2	1089-20	Suction Cover	1
3	1089-13	Discharge Line Ass'y.	1
4	D-2483A	"Y" Strainer 1/2	1
	1089-25	Spinner Ass'y. - Wash.	(2 Ref.)
5	1084-76	Spray Hub-Wash	2
6	952-27	Bushing	2
7	1089-23	Spray Pipes	4
8	D2-554-2	Plug 3/4-10 UNC - 2A	4
9	952-28A	Locking Screw	2
	1089-26	Spinner Ass'y. - Rinse	(2 Ref.)
10	372-52	Spray Hub-Rinse	2
11	1084-35	Bushing - Upper	2
12	1084-36	Bushing - Lower	2
13	1089-24	Spray Pipes - Rinse	2 ea.
14	D-2296	Spray Nozzles - Rinse	8
15	D2-554-1	Plug 9/16 - 12 UNC - 2 A	4
16	D-2241A	Vacuum Breaker 1/2	1
17	D-2242A	Vacuum Breaker Repair Kit	1
18	1089-31C	Final Rinse Piping Ass'y. (Vertical)	1
19	954-1A	Drain Ass'y.	1
20	1100-79	Drain Handle Ass'y	1
21	D-2450	Solenoid Valve 1/2	1
22	D-2495	Temp. Gauge - Final Rinse	1
23	D-2390	Temperature Gauge	1
24	D2-754A	Guard Temp. Gauge	1
25	1084-14A	Track Ass'y.	2
26	1089-31B	Final Rinse Piping Ass'y. (Lower)	1
27	1089-31A	Final Rinse Piping Ass'y. (Upper)	1
28	1089-9	Tray Support	2
29	1089-10	Scrap Screen	1
30	D-2430	Bullet Foot	4
31	1089-8	Door - Side	2
32	1084-25	Door Arm	1
33	1084-38	Link - Door Arm	2
34	957-26	Spacer - Door Arm Link	2
35	1084-39	Pivot Bracket - Door Arm	2
36	D-2245	Grip-Door Handle	2
37	SK-2294A	Spring	2
38	957-27	Spring Extension- Lower	2
39	1089-12	Spring Bracket	1
40	1089-17	Bracket - Microswitch	1
41	D-2215A	Microswitch	1
42	1089-57	Door - Front	1
43	D-2099	Door Handle	1
44	1089-59	Door Hanger	1
45	SK-2833	Control Box assembly	1
46	DES-37	MAGNET/SWITCH	1

*Specify Voltage or see Product Data Sheet

SK-2836

INSINGER MACHINE CO. PHILA. PA. 19135 (215) 624-4800

PARTS LIST CS-4

<u>ITEM</u>	<u>PART NO.</u>	<u>DESCRIPTION</u>	<u>REQ.</u>
1	D-2465	Tray & Motor Ass'y. (1 HP)*	1
2	1089-20	Suction Cover	1
3	1089-13	Discharge Line Ass'y.	1
4	D-2483A	"Y" Strainer 1/2	1
	1089-25	Spinner Ass'y. - Wash.	(2 Ref.)
5	1084-76	Spray Hub-Wash	2
6	952-27	Bushing	2
7	1089-23	Spray Pipes	4
8	D2-554-2	Plug 3/4-10 UNC - 2A	4
9	952-28A	Locking Screw	2
	1089-26	Spinner Ass'y. - Rinse	(2 Ref.)
10	372-52	Spray Hub-Rinse	2
11	1084-35	Bushing - Upper	2
12	1084-36	Bushing - Lower	2
13	1089-24	Spray Pipes - Rinse	2 ea.
14	D-2286	Spray Nozzles - Rinse	8
15	D2-554-1	Plug 9/16 - 12 UNC - 2 A	4
16	D-2241A	Vacuum Breaker 1/2	1
17	D-2242A	Vacuum Breaker Repair Kit	1
18	1089-62C	Final Rinse Piping Ass'y. (Vertical)	1
19	954-1A	Drain Ass'y.	1
20	1100-79	Drain Handle Ass'y	1
21	D-2450	Solenoid Valve 1/2	1
22	D-2495	Temp. Gauge - Final Rinse	1
23	D-2390	Temperature Gauge	1
24	D2-754A	Guard Temp. Gauge	1
25	1084-14A	Track Ass'y.	2
26	1089-62B	Final Rinse Piping Ass'y. (Lower)	1
27	1089-62A	Final Rinse Piping Ass'y. (Upper)	1
28	1089-9	Tray Support	2
29	1089-10	Scrap Screen	1
30	D-2430	Bullet Foot	4
31	1089-8	Door - Side	2
32	1084-25	Door Arm	1
33	1084-38	Link - Door Arm	2
34	957-26	Spacer - Door Arm Link	2
35	1084-39	Pivot Bracket - Door Arm	2
36	D-2245	Grip-Door Handle	2
37	SK-2294A	Spring	2
38	957-27	Spring Extention- Lower	2
39	1089-12	Spring Bracket	1
40	1089-17	Bracket - Microswitch	1
41	D-2215A	Microswitch	1
42	1089-57	Door - Front	1
43	D-2099	Door Handle	1
44	1089-59	Door Hanger	1
45	SK-2833	Control Box assembly	1
46	DES-37	MAGNET/SWITCH	1

*Specify Voltage or see
Product Data Sheet

SK-2836A

INSINGER MACHINE CO.
PHILA. PA. 19135 (215) 624-4800

Rev 6.22.87

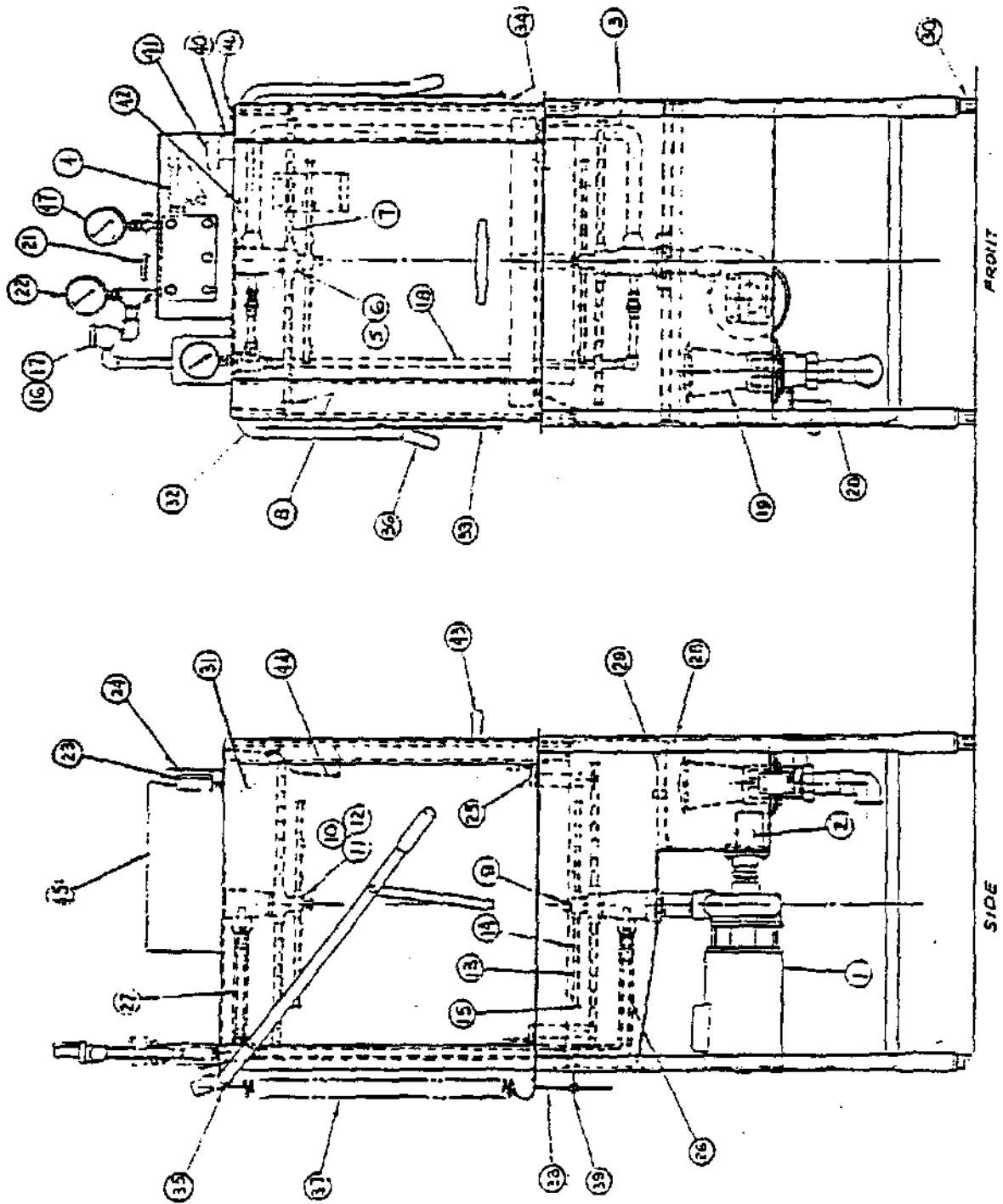

S.K. 2836
 PG. 1 OF 2

INSINGER MACHINE CO.
 PHILA. PA. 19135 (2181 624-4600)

6p 6.2.2.2.2.

PARTS LIST - Corner Model

<u>ITEM</u>	<u>PART NO.</u>	<u>DESCRIPTION</u>	<u>REQ.</u>
	D-2465	Pump & Motor Ass'y. (1 HP)*	1
	1089-20	Suction Cover	1
3	1089-111	Discharge Line Ass'y.	1
4	D-2483A	"Y" Strainer 1/2	1
	1089-25	Spinner Ass'y. - Wash.	(2 Ref.)
5	1084-76	Spray Hub-Wash	2
6	952-27	Bushing	2
7	1089-23	Spray Pipes	4
8	D2-554-2	Plug 3/4-10 UNC - 2A	4
9	952-28A	Locking Screw	2
	1089-26	Spinner Ass'y. - Rinse	(2 Ref.)
10	372-52	Spray Hub-Rinse	2
11	1084-35	Bushing - Upper	2
12	1084-36	Bushing - Lower	2
13	1089-24	Spray Pipes - Rinse	2 ea.
14	D-2286 A	Spray Nozzles - Rinse	8
15	D2-554-1	Plug 9/16 - 12 UNC - 2 A	4
16	D-2241A	Vacuum Breaker 1/2	1
17	D-2242A	Vacuum Breaker Repair Kit	1
18	1089-31C	Final Rinse Piping Ass'y. (Vertical)	1
19	954-1A	Drain Ass'y.	1
20	1100-79	Drain Handle Ass'y	1
21	D-2450	Solenoid Valve 1/2	1
22	D-2495 R	Temp. Gauge - Final Rinse	1
23	D-2390	Temperature Gauge	1
24	D2-754A	Guard Temp. Gauge	1
25	1089-107	Track Ass'y.	1
26	1089-31B	Final Rinse Piping Ass'y. (Lower)	1
27	1089-31A	Final Rinse Piping Ass'y. (Upper)	1
28	1089-9	Tray Support	2
29	1089-10	Scrap Screen	1
30	D-2430	Bullet Foot (Commercial Only)	4
31	1089-8	Door - Side	2
32	1084-126	Door Arm	1
33	1084-119	Link - Door Arm	2
34	957-26	Spacer - Door Arm Link	2
35	952-118	Pivot Bracket - Door Arm	2
36	952-139	Support - Pivot Bracket	2
37	SK-2294A	Spring	2
38	957-27	Spring Extension- Lower	2
39	1089-118	Spring Bracket	1
40	1084-137	Bracket - Microswitch	1
41	D-2215A	Microswitch	1
42	957-49	Spring Extension - Upper	2
43	1089-108	Corner Track	1
44	SK-2833	Control Box Assembly	1

Specify voltage or see
Product Data Sheet

SK-2837

INSINGER MACHINE CO. PHILA., PA. 19135 (215) 624-4800

Ref 5-22-87

PG. 2 OF 2

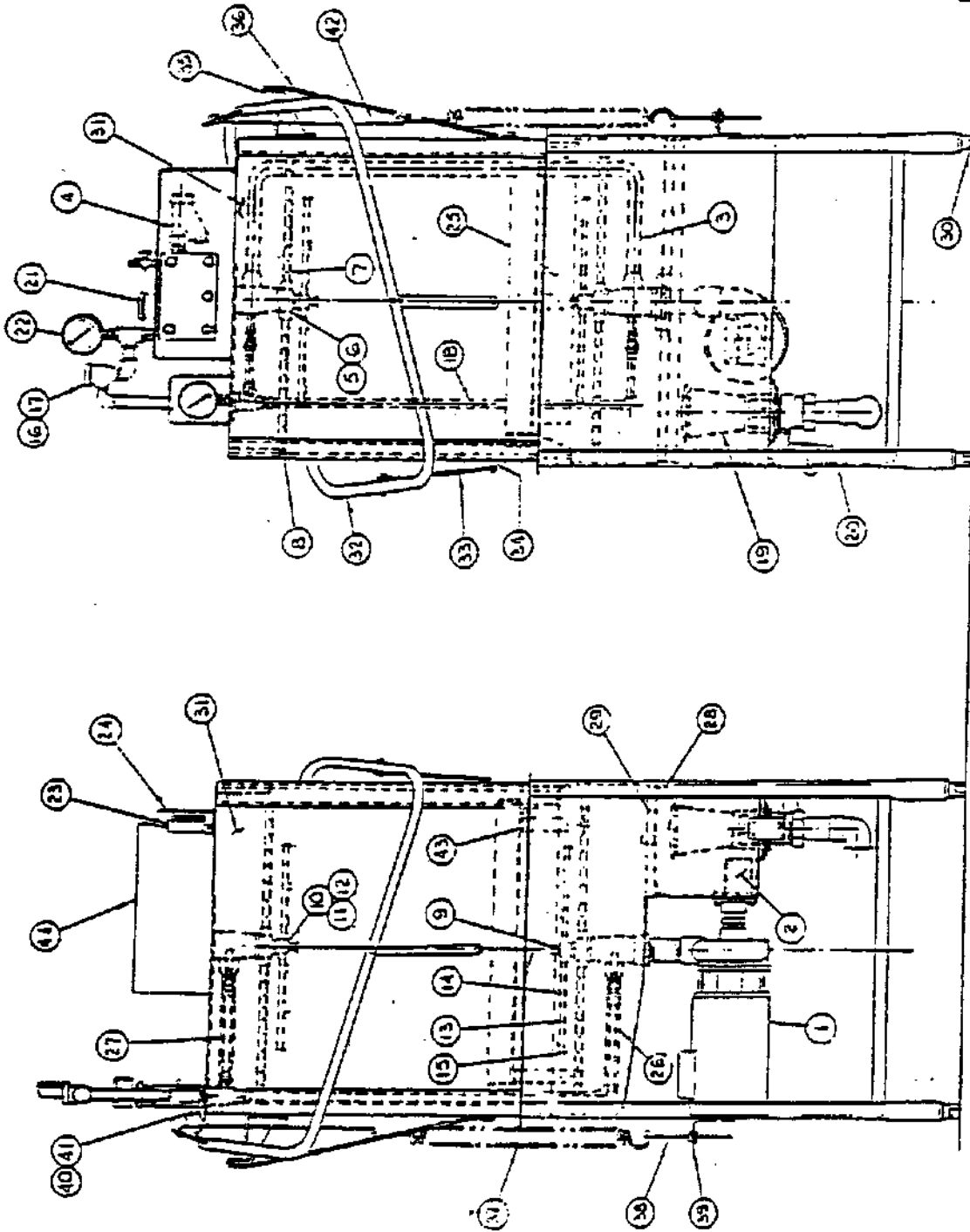

AIDE

E.ROUILL.

511 - 2837

REV. 1913

INSINGER MACHINE CO.
PHILA. PA. 19138 12151 611 4800

511 - 2837

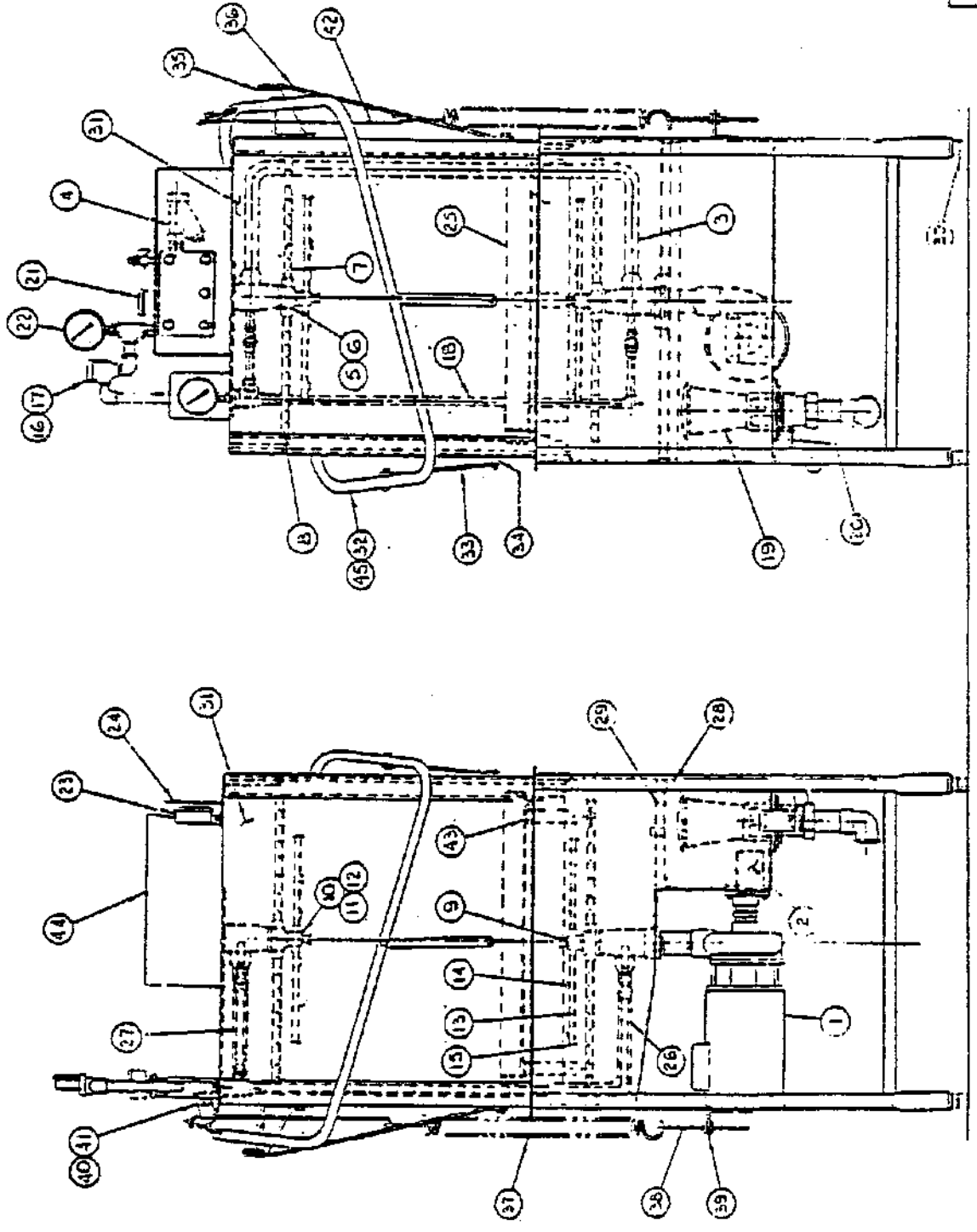

INSINGER

SIDE

PARTS LIST CS-4C

<u>ITEM</u>	<u>PART NO.</u>	<u>DESCRIPTION</u>	<u>QTY</u>
1	D-2465	Pump & Motor Ass'y. (1 HP)	1
2	1089-20	Suction Cover	1
3	1099-111	Discharge Line Ass'y.	1
4	D-2483A	"Y" Strainer 1/2	1
	1089-25	Spinner Ass'y. - Wash.	(2 Pk)
5	1084-76	Spray Hub-Wash	2
6	952-27	Bushing	2
7	1089-23	Spray Pipes	4
8	D2-554-2	Plug 3/4-10 UNC - 2A	4
9	952-29A	Locking Screw	2
	1089-26	Spinner Ass'y. - Rinse	(2 Pk)
10	372-52	Spray Hub-Rinse	2
11	1084-35	Bushing - Upper	2
12	1084-36	Bushing - Lower	2
13	1089-24	Spray Pipes - Rinse	2
14	D-2286 A	Spray Nozzles - Rinse	8
15	D2-554-1	Plug 9/16 - 12 UNC - 2 A	4
16	D-2241A	Vacuum Breaker 1/2	1
17	D-2242A	Vacuum Breaker Repair Kit	1
18	1089-62C	Final Rinse Piping Ass'y. (Vertical)	1
19	954-LA	Drain Ass'y.	1
20	1100-79	Drain Handle Ass'y	1
21	D-2450	Solenoid Valve 1/2	1
22	D-2495 R	Temp. Gauge - Final Rinse	1
23	D-2390	Temperature Gauge	1
24	D2-754A	Guard Temp. Gauge	1
25	1089-107	Track Ass'y.	1
26	1089-62B	Final Rinse Piping Ass'y. (Lower)	1
27	1089-62A	Final Rinse Piping Ass'y. (Upper)	1
28	1089-9	Tray Support	2
29	1089-10	Scrap Screen	1
30	D-2430	Bullet Foot (Commercial Only)	4
31	1089-8	Door - Side	2
32	1084-126	Door Arm	1
33	1084-119	Link - Door Arm	2
34	957-26	Spacer - Door Arm Link	2
35	952-118	Pivot Bracket - Door Arm	2
36	952-139	Support - Pivot Bracket	2
37	SK-2294A	Spring	2
38	957-27	Spring Extension- Lower	2
39	1089-118	Spring Bracket	1
40	1084-137	Bracket - Microswitch	1
41	D-2215A	Microswitch	1
42	957-49	Spring Extension - Upper	2
43	1089-108	Corner Track	1
44	SK-2833	Control Box Assembly	1

*Specify voltage or see
Product Data Sheet

SK-2837A

INSINGER MACHINE CO.
PHILA., PA. 19135 (215) 624-4800

Rev 6.22.87

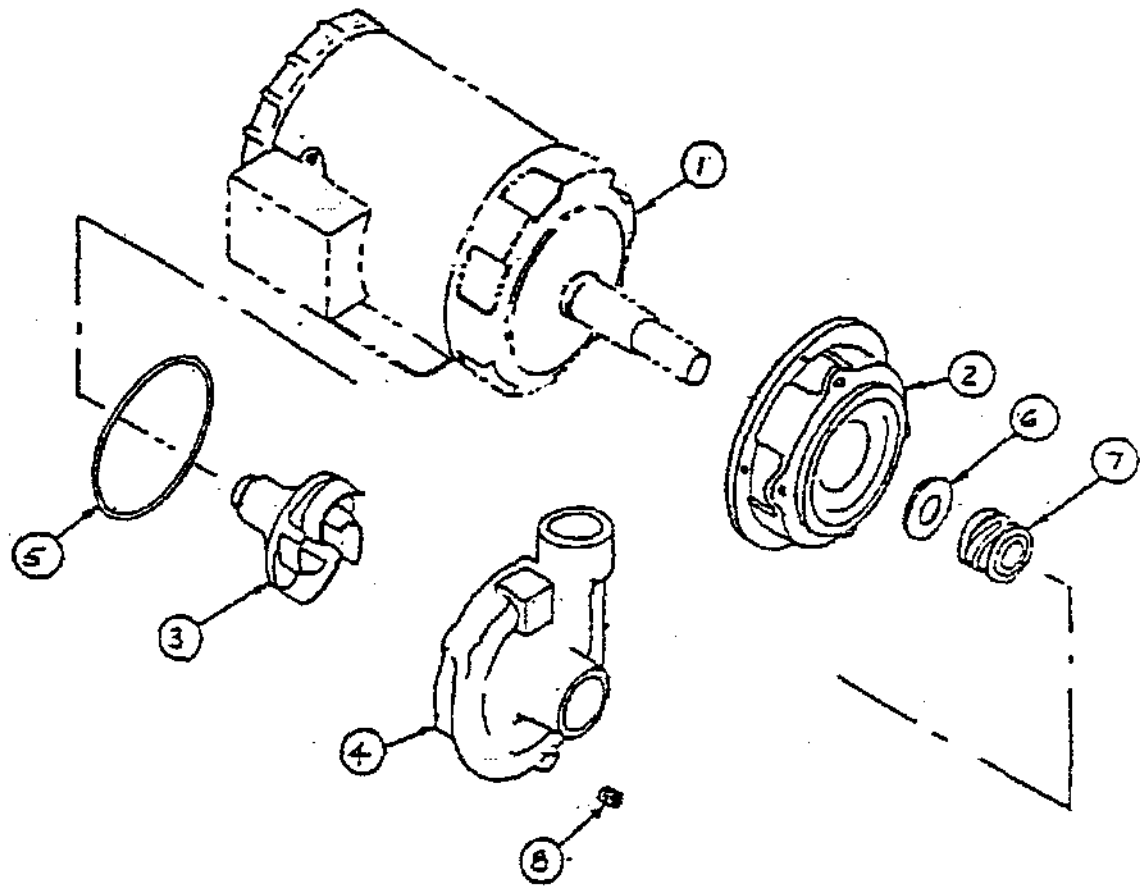

PARTS LIST - 1 HP PUMP

ITEM	PART NO.	PART NAME	REQ'D
1	*	Motor	1
2	D-431	Adapter	1
3	D-436	Impeller 3 7/8	1
4	D-434	Casing	1
5	D2-532	"O" Ring	1
6	D2-533	Flinger	1
7	D2-534	Seal Assembly	1
8		Drain Plug 1/4 IPS	1

Complete Pump & Motor - Part No. D-2465-1 - Single phase
 D-2465-3 - Three phase

* See Product Data Sheet

INSINGER MACHINE CO.
 PHILA. PA. 19135 (215) 624-4800

SK-2462

R/F 1.30.87

INSINGER DRAIN ASSEMBLY

ITEM	PART NO.	NAME OF PART	REQ.
	954-50	Drain Ass'y. (Comp)	-
1	954-50A	Upper Body	1
2	954-50B	Lower Body	1
3	954-50C	Nut	1
4	954-50D	Overflow Tube	1
5	D-193	Skimmer Cap	1
6	D2-557	"V" Seal-drain Seat	1
7	D2-548	"O" Ring	1
8	D2-549	"O" Ring	1
9	D-305	Drain Jam Nut	1
10	D2-550	"O" Ring	1
11	1100-79	Drain Handle Ass'y.	1
12	954-8C	Bracket	1
13	D-2407	Ball	1

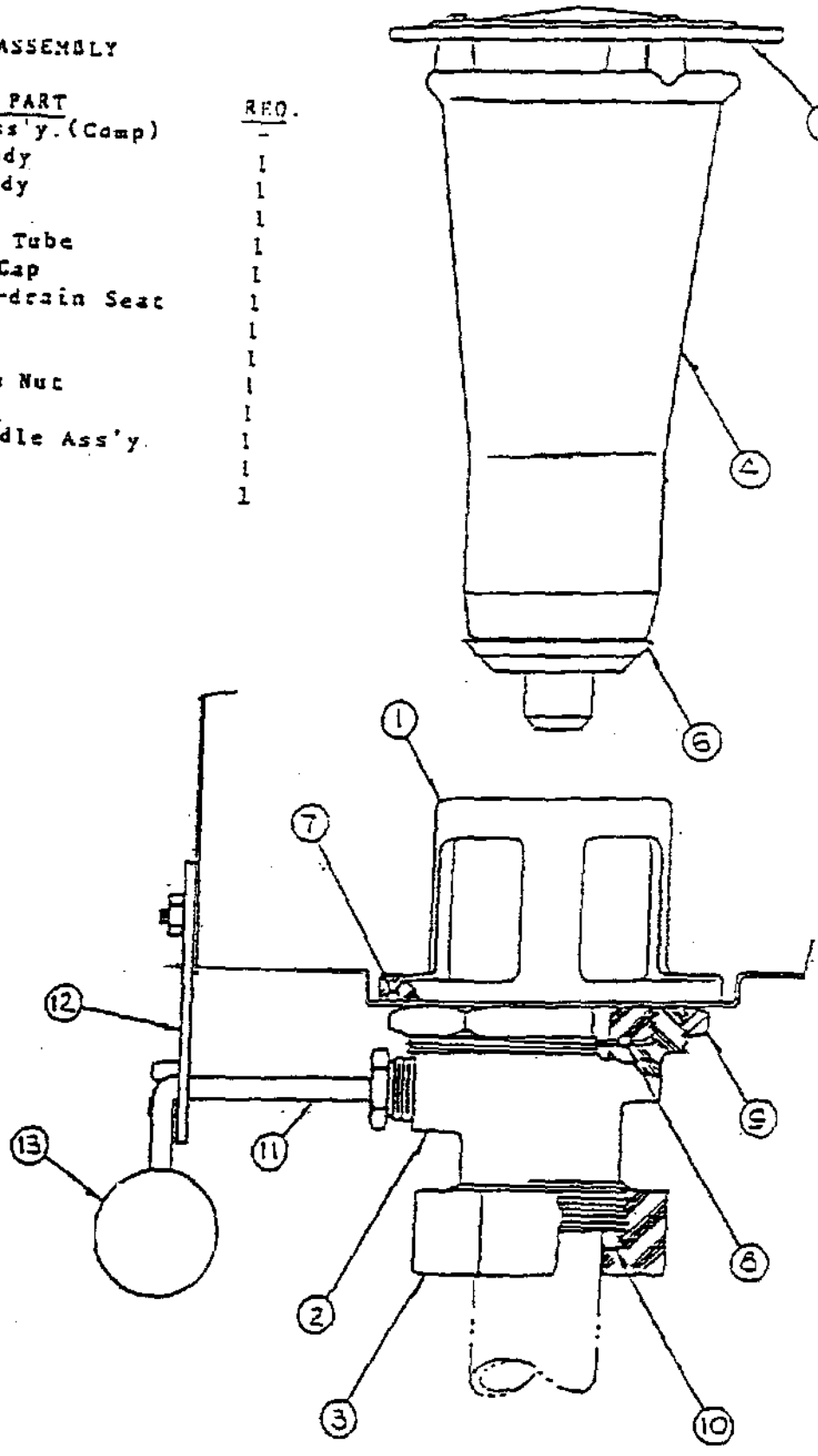

INSINGER MACHINE CO.
 PHILA. PA. 19135 (215) 624-4800

In order to insure the proper operation of your INSINGER dishwasher, it is necessary that the LIQUID LEVEL FLOAT be wiped free of any residue and/or moisture at each cleaning. This should be done, preferably, after each use of the machine, or, at a minimum, once each day.

The LIQUID LEVEL FLOAT is located below the scrap screens in those tanks which contain water heating devices (coils, steam injectors, or electric immersion heaters) and pump inlet strainers. They are usually located, in rackless and rack conveyor style machines, on the inside tank wall, at approximately water level, opposite and parallel to the inspection doors. In the door, stationary rack, type machines, the LIQUID LEVEL FLOAT may be found beneath the scrap screen.

Below is a depiction of the LIQUID LEVEL FLOAT and the surfaces which must be wiped clean.

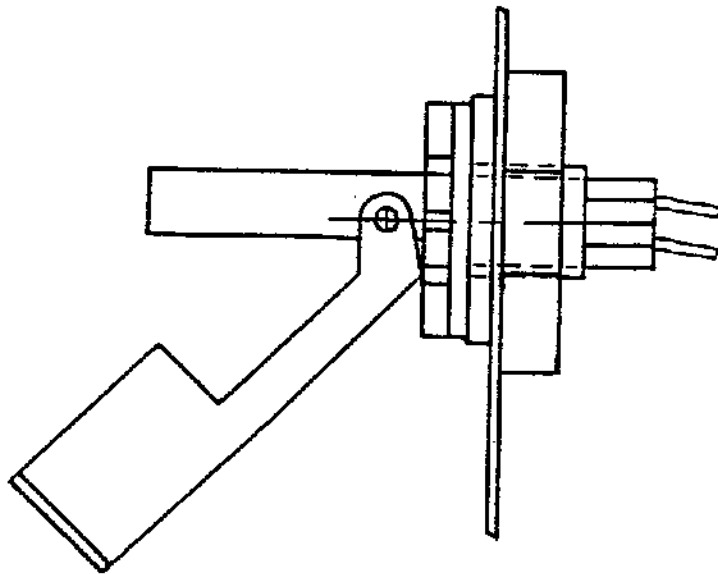



NO.	DESCRIPTION	PART NO.	QTY.
1	LOCKNUT, HEX 1/2 IPS	DJ26F-01	1
2	NIPPLE, CLOSE 1/2 IPS	DJ14F-0C-00	5
3	TEE 1/2 IPS	DJ20F-01D101	3
4	PLUG, PIPE 1/2 IPS	DJ28F-02-A	1
5	UNION, STRAIGHT 1/2 IPS	DJ18F-01-01	1
6	NIPPLE, PIPE 1/2 IPS x 4 1/2" LG.	DJ14F-05-36	1
7	ELBOW, 90° STREET 1/2 IPS	DJ16F-01-02	2
8	BREAKER, VACUUM 1/2 IPS	D-2241A	1
9	NIPPLE, PIPE 1/2 IPS x 2" LG.	DJ14F-05-16	2
10	REDUCER, HEX 1/2 MIPPS x 1/4 FIPS	DJ22F-02-B1	2
11	GAUGE, TEMPERATURE 1/4 IPS	D-2495R	1
12	ELBOW, 90° 1/2 IPS	DJ18F-01-01	1
13	VALVE, SOLENOID (WATER) 1/2 IPS	D-2608	1
14	BRACKET, PIPING SUPPORT	DWG. 951-79	1
15	PETCOCK 1/4 IPS	D2497	1
16	GAUGE, PRESSURE 1/4 IPS	SK-1433	1
17	TEE 1/2 IPS	* DJ20E-01D101	1
18			
19	ADAPTER 1/2 MIPPS x 1/2 C	* DJ17E-03-02	2
20	TUBING, S/S 1/2 CTS x 9" LG.	D207C-84-36	1
21	UNION 1/2 FIPS x 1/2 C	* DJ18E-03-01	2
22	REDUCER, FLUSH 1/2 MIPPS x 3/8 FIPS	* DJ21E-02-C1	2
23			
24	TUBING, S/S 1/2 CTS x 28" LG.	D207C-84-112	1
25	ELBOW, 90° 1/2 C	* DJ16E-0J-0J	1
26	TUBING, S/S 1/2 CTS x 9 3/4" LG.	D207C-84-39	1
27	ASS'Y, SPINNING SPRAY PIPE (WASH)	DWG. 1089-25	2
28	ASS'Y, SPINNING SPRAY PIPE (RINSE)	DWG. 1089-26	2
29	SCREW, LOCKING	D2-584	2
30	STRAINER, "Y" 1/2 IPS	D-2483A	1

NOTES:

- USED ON 18-3, 18-3 W/FRONT DOOR, 18-3C (CORNER MODEL) & 50-20N2-NSU.
- "*" INDICATES CHROME PLATED.
- ITEM #30 IS NOT REQUIRED WHEN A BOOSTER IS SPECIFIED, REPLACE WITH 90° UNION ELBOW 1/2 MIPPS X 1/2 COPPER
- ITEM #30 & #13 ARE NOT REQUIRED WHEN USING A SELF-CONTAINED BOOSTER.
- FOR MODEL 50-20N2-NSU, REPLACE ITEM #14 WITH 1084-85, ITEM #6 WITH 3/4 IPS x 1 1/2" LG. BRASS NIPPLE (DJ14F-06) & ADD A 90° STREET ELBOW 1/2 MIPPS x 3/4 FIPS (DJ18F-02-E1) TO INLET END OF "Y" STRAINER.

1089-27
PG. 2 OF 2

-  ECN# 679 7.8.92
-  ECN# 563 6.08.91
-  ECN# 511 11.27.90

FILE: PARTS\108927-2

SUPERSEDES DWG. SAME NO. DATED 03.04.87

PG. 2 OF 2

TOLERANCES: FRACTIONS ± 1/64" DECIMAL ± .002" ANGULAR ± 1/2°	TITLE FINAL RINSE ASSEMBLY	PATT. NO.	DWG. NO. 1089-27
	DATE NOTED	SCALE N/A	USED ON NOTED
UNLESS OTHERWISE SPECIFIED	INSINGER MACHINE CO. PHILA. PA. 19138-2906 (215) 624-4800		RAF 11.19.90

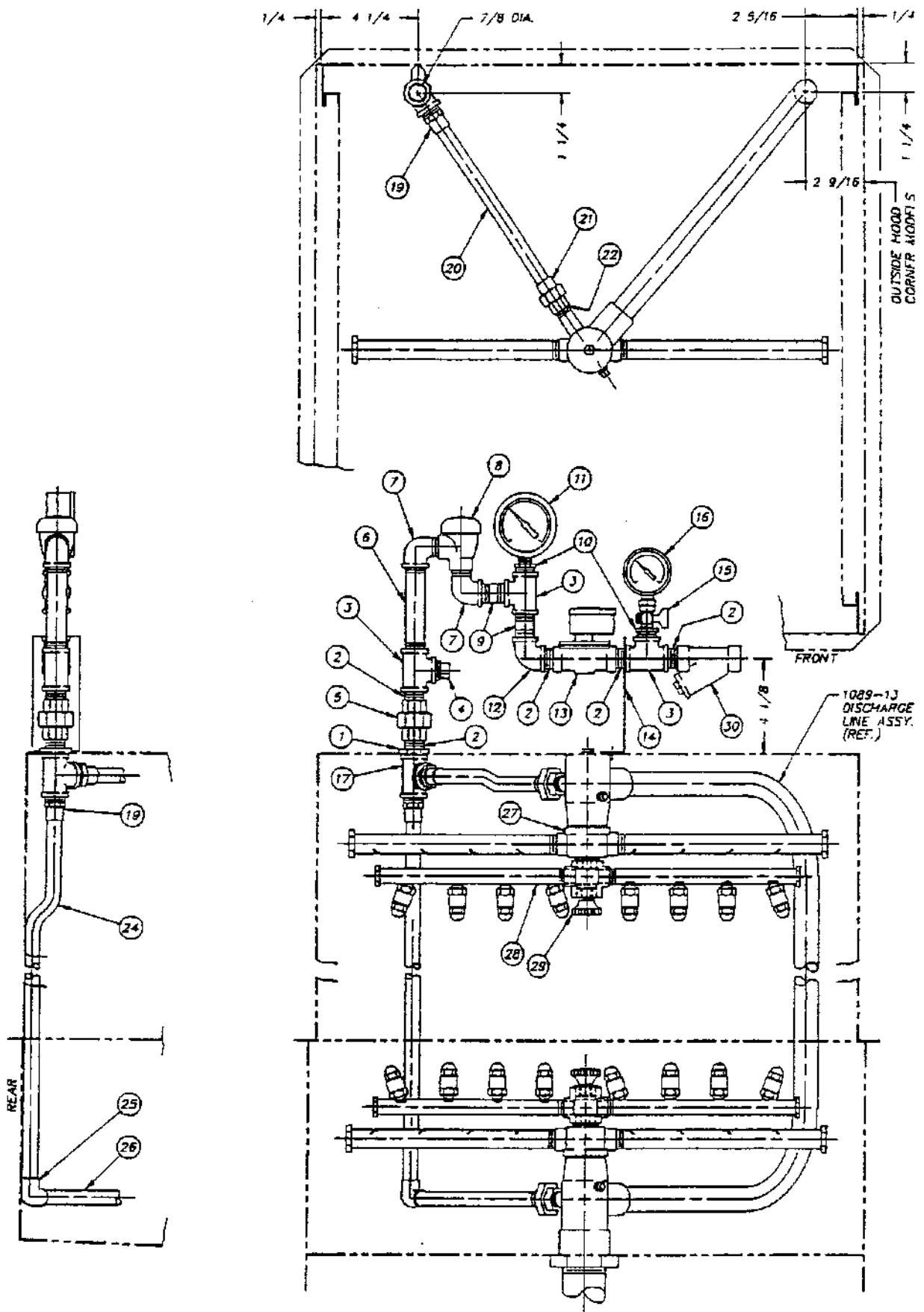

G EON# 678 7.8.82
 F EON# 563 6.08.81

FILE: PARTS\108927-1

SUPERSEDES DWG. SAME NO. DATED 03.04.87

PG. 1 OF 2

TOLERANCES: FRACCTIONS = 1/64" DECIMAL = .005" ANGULAR = 1/2"	TITLE FINAL RINSE ASSEMBLY	PATT. NO. NOTED	DWG. NO. 1089-27
UNLESS OTHERWISE SPECIFIED	SCALE 1/4	USED ON SEE PG. 2 OF 2	DATE 11.19.90
INSINGER MACHINE CO. PHILA. PA. 19135-2996 (215) 924-4800		RAP	

NO.	DESCRIPTION	PART NO.	QTY.
1	LOCKNUT, HEX 1/2 IPS.	D326F-01	1
2	NIPPLE, CLOSE 1/2 IPS	D314F-0C-00	2
3	TEE 1/2 IPS	D320F-010101	3
4	PLUG, PIPE 1/2 IPS	D328F-02-A	1
5	UNION, STRAIGHT 1/2 IPS	D318F-01-01	1
6	NIPPLE, PIPE 1/2 IPS x 4 1/2 LG.	D314F-0S-36	1
7	ELBOW, 90° STREET 1/2 IPS	D316F-02-01	2
8	BREAKER, VACUUM 1/2 IPS	D-2241A	1
9	NIPPLE, PIPE 1/2 IPS x 2 LG.	D314F-0S-16	2
10	REDUCER, HEX 1/2 MPS x 1/4 FPS	D322F-02-B1	2
11	GAUGE, TEMPERATURE 1/4 IPS	D-249SR	1
12	ELBOW, 90° 1/2 IPS	D316F-01-01	1
13	NIPPLE, PIPE 1/2 IPS x 4 LG.	D314F-0S-32	1
14	BRACKET, PIPING SUPPORT	DWG. 831-79	1
15	PETCOCK 1/4 IPS	D2487	1
16	GAUGE, PRESSURE 1/4 IPS	SK-1433	1
17	TEE 1/2 IPS	* D320E-010101	1
18	NIPPLE, CLOSE 1/2 IPS	* D314E-0C-00	1
19	ADAPTER 1/2 MPS x 1/2 C	* D317E-03-02	2
20	TUBING, S/S 1/2 ODS x 9 LG.	D207C-84-38	1
21	UNION 1/2 FPS x 1/2 C	* D318E-03-01	2
22	REDUCER, FLUSH 1/2 MPS x 3/8 FPS	* D323E-02-C1	2
23	VALVE, BALL CHECK 1/2 IPS	* D-2433J	1
24	TUBING, S/S 1/2 ODS x 28 1/2 LG.	D207C-84-108	1
25	ELBOW, 90° 1/2 C	* D316E-03-03	1
26	TUBING, S/S 1/2 ODS x 9 3/4 LG.	D207C-84-38	1
27	ASSY, SPINNING SPRAY PIPE (WASH)	DWG. 1069-25	2
28	ASSY, SPINNING SPRAY PIPE (RINSE)	DWG. 1069-26	2
29	SCREW, LOCKING	D2-584	2

NOTES:

1. "*" INDICATES CHROME PLATED.

2. USED ON MODEL 18-3 WITH
SELF CONTAINED BOOSTER.

PG. 2 OF 2

1192-10
PG. 2 OF 2

 EDW/SOB 11.20.90

FILE \ACAD\PARTS\119210-2

DIMENSIONS FINISHED & 1/8" ORIGINAL & .001" APPROX & 1/2"	FILE FINAL RINSE ASSEMBLY (SELF CONTAINED BOOSTER)	PART NO. NOTED 1192-10	QTY. 1
MADE SPECIFIC SPECIFIED	NOTED	DATE N/A	CHKD BY OR. 12-3
INSINGER MACHINE CO. PHILA., PA. 19128-1000 (TEL) 681-4800			RAF 11.25.90

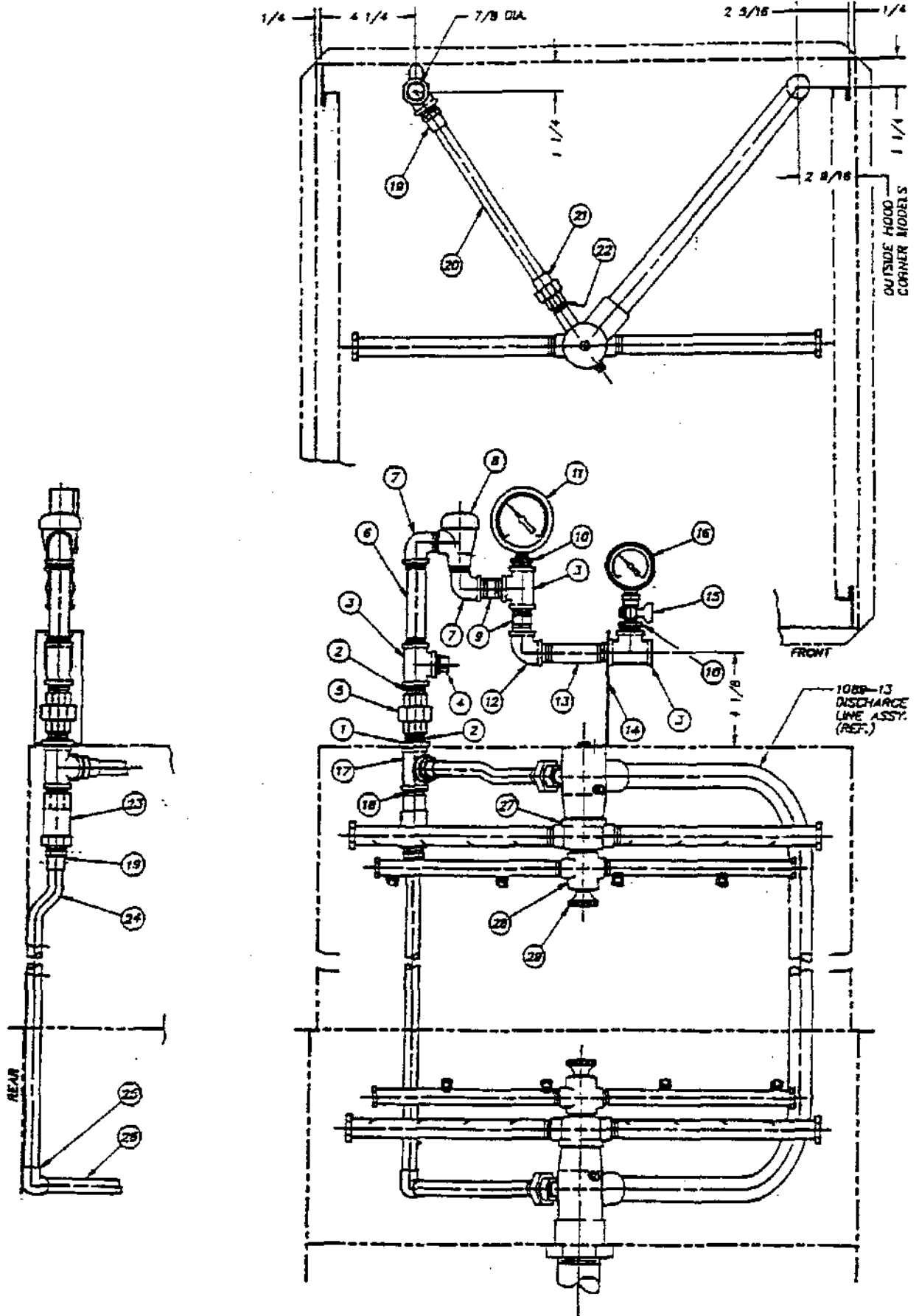

1192-10
01-2011

FED \ACAD\PARTS\119210-1

PG. 1 OF 2

MANUFACTURER PARTS NO. 1192-10 SERIAL NO. 1192-10 APPROVAL 11/2	FILE FINAL RINSE ASSEMBLY (SELF CONTAINED BOOSTER)	DATE REV. REVISED SCALE 1/4"	FILE NO. 1192-10 REV. OR ORG. NO. 1 11.15.20
DETL. SEE PG. 2 OF 2		INSINGER MACHINE CO. PHILA., PA. SPEC. 6204 (25) 624-4800	

NO.	DESCRIPTION	PART NO.	QTY.
1	STEAM COIL ASS'Y - COPPER	1089-32	1
	STEAM COIL ASS'Y - S/S	1089-32A	1
2	LOCKNUT	D326A-D	2
3	NIPPLE	D314A-D18-LOE	1
4	90° STREET EL	D316A-D1-D2	1
5	*Y* STRAINER	D-2483A	1
6	SOLENOID	D-2594	1
7	CLOSE NIPPLE	D314A-DCL	1
8	STEAM TRAP	D-2102	1
9	NIPPLE	D314A-D10-LOE	1
10	RED COUPLING	D321A-D1-C1	1
11	90° STREET EL	D316A-C1-C2	1
12	CLOSE NIPPLE	D314A-CCL	1

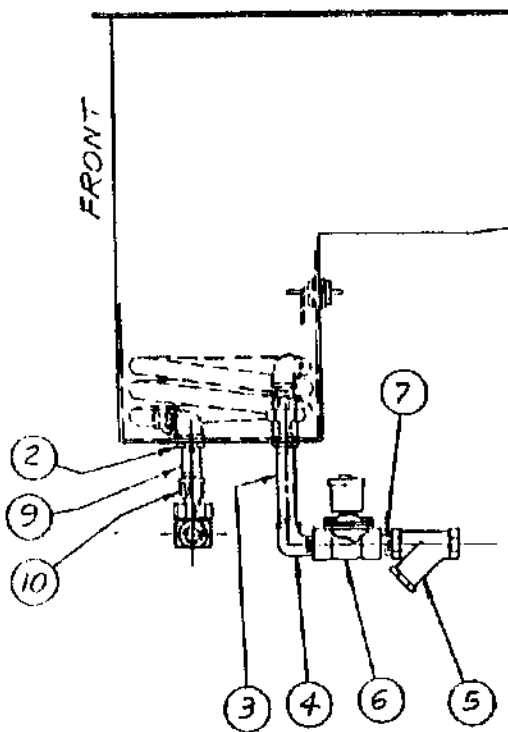
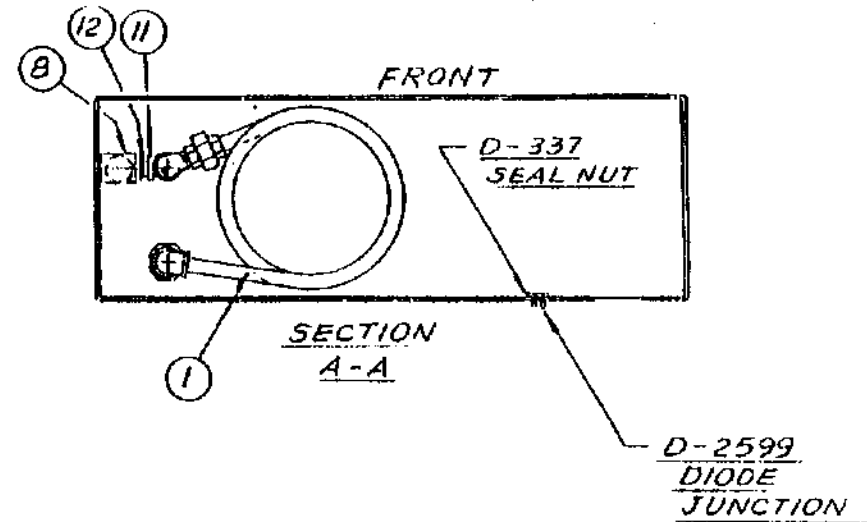

USED ON:
COMMANDER 18-3, 18-3C
CS-4, CS-4C

NOTES:
DO NOT USE COPPER COILS
ON CS-4 MACHINES!

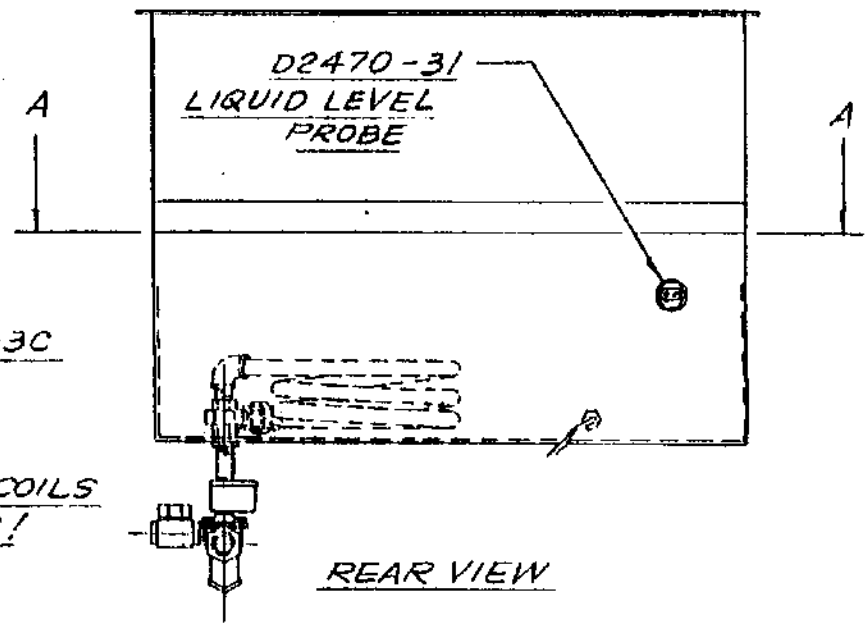

TOLERANCES FRACTIONS ± 1/64 DECIMAL ± .005 ANGULAR ± 1/2° UNLESS OTHERWISE SPECIFIED	TITLE STEAM COIL, DIODE JCT. & LIQUID LEV. PROBE	PATT. NO.	DWG. NO.
	MATL. NOTED	REQ. NOTED	SK-2830
		SCALE 1/8	USED ON NOTED
	INSINGER MACHINE CO. PHILA., PA. 19135 (215) 624-4800		Raf 5.1.87

NO.	DESCRIPTION	PART NO.	QTY.
1	STEAM INJECTOR	D-942	1
2	LOCKNUT	D326A-D	2
3	NIPPLE	D314A-D10-AT	1
4	90° STREET ELBOW	D316A-D1-D2	2
5	CHECK VALVE	D-2453	1
6	CLOSE NIPPLE	D314A-DCL	2
7	"Y" STRAINER	D-2483A	1
8	SOLENOID VALVE	D-2490	1

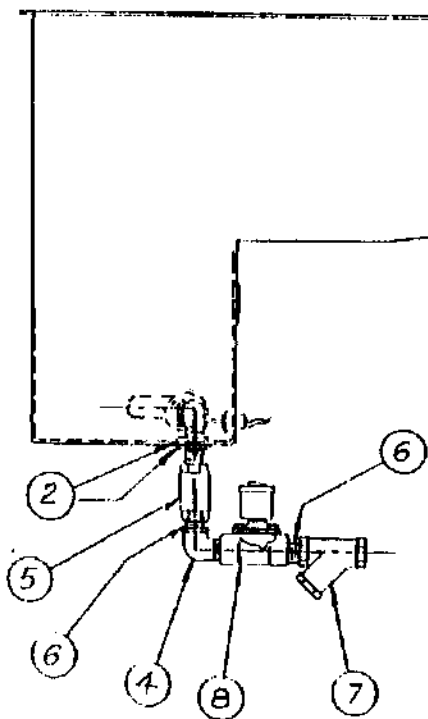
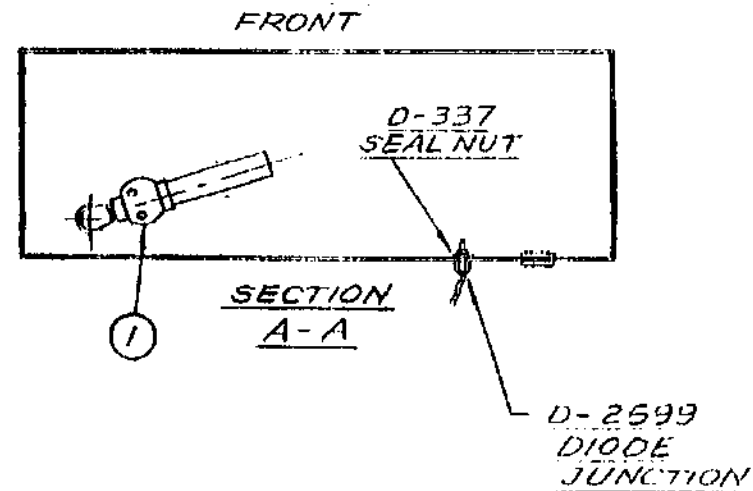

USED ON
 COMMANDER 18-3, 18-3C,
 CS-4, CS-4C

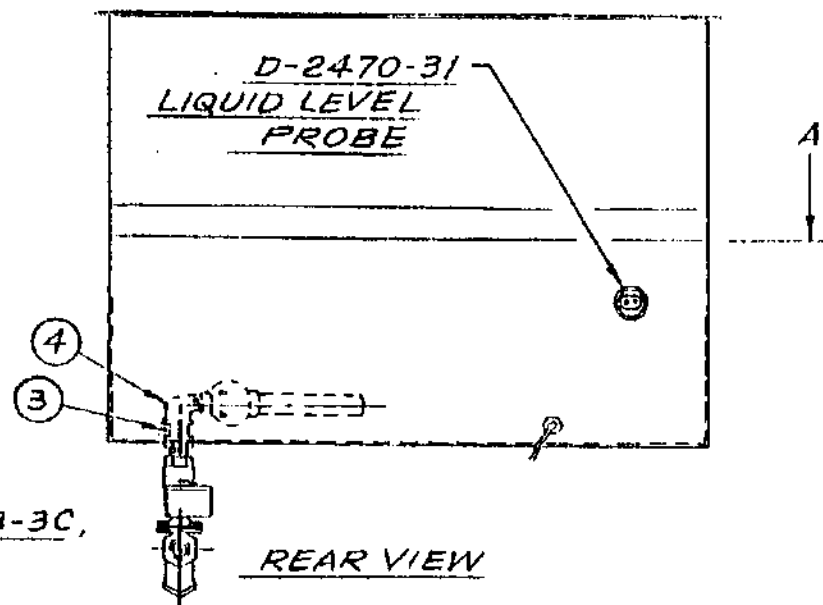

TOLERANCES FRACTIONS $\pm 1/64$ DECIMAL $\pm .005$ ANGULAR $\pm 1/2^\circ$ UNLESS OTHERWISE SPECIFIED	TITLE STEAM INJECTOR, DIODE JCT. & LIQUID LEV. PROBE	PATT. NO.	DWG. NO.
	MATL. NOTED	REQ. NOTED	SK-2829
		SCALE 1/8	USED ON NOTED
	INSINGER MACHINE CO. PHILA., PA. 19135 (215) 624-4800		RAF 5.1.87



Insinger Machine Company
6245 State Road
Philadelphia, PA 19135-2996
800-344-4802
Fax: 215-624-6966
www.insingermachine.com