



TECHNICAL MANUAL

Installation, Operation and Maintenance Instructions

LT-40 SERIES

HIGH TEMPERATURE DOOR TYPE

LT-40 S

LT-40 H

Insinger Machine Company
6245 State Road
Philadelphia, PA 19135-2996

800-344-4802
Fax: 215-624-6966
www.insingermachine.com

Thank you for purchasing a quality Insinger product.

In the space provided below please record the model, serial number and start-up date of this unit:

Model: _____

Serial Number: _____

Start-Up Date: _____

When referring to this equipment please have this information available.

Each piece of equipment at Insinger is carefully tested before shipment for proper operation. If the need for service should arise please contact your local Authorized Insinger Service Company.

To find your local authorized Service Company please visit our web site, www.insingermachine.com or call Insinger at 800-344-4802.

Please read the Insinger Limited Warranty and all installation and operation instructions carefully before attempting to install or operate your new Insinger product.

To register your machine for warranty, or for answers to question concerning installation, operation, or service contact our Technical Service Department.

TECHNICAL SERVICE CONTACTS	
Toll-Free	800-344-4802
Fax	215-624-6966
e-mail	service@insingermachine.com
Web site	www.insingermachine.com

TABLE OF CONTENTS

Part 1 Technical Information <ul style="list-style-type: none"> • Specification Sheets • Introduction • Definitions • Safety Summary • Warranty 	1-6
Part 2 Installation Instructions <ul style="list-style-type: none"> • General Installation Instructions • Electrical Characteristics • Pump Priming Instructions • CAM Timer Settings • Installation Drawings 	7-11
Part 3 Operation Instructions	12
Part 4 Cleaning Instructions <ul style="list-style-type: none"> • Daily Cleaning Instructions • Weekly Cleaning Instructions • Delime Instructions 	13
Part 5 Maintenance and Repair Procedures <ul style="list-style-type: none"> • Maintenance Requirements • Maintenance Procedures • Troubleshooting 	14-15
Part 6 Assembly Drawings <ul style="list-style-type: none"> • Assembly Drawings with Parts Lists • Motor Assembly: 3/4HP, 1HP 	16-33
Part 7 Electrical Schematics	34-35
Part 8 False Panel Assembly	36



ESSENTIAL SERIES

Project _____
Item _____
Quantity _____
CSI - 11400 _____
Approval _____
Date _____

LT-40^S

Low Temperature Chemical Sanitizing Door Type Dishwasher

- Automatic door type, single tank dishwasher with timed detergent, sanitizer, and rinse cycle
- 1.02 gallon/rack
- Capacity is 40 (20" x 20") racks per hour
- Field convertible from straight through to corner

STANDARD FEATURES

- SureFire® Start-Up & Check-Out Service
- Non-proprietary commercially available pump and parts
- "Easy Clean" front-mounted wash tank
- 1 HP 3500 RPM Pump Motor, GPM 55 @15 PSI
- Top-mounted NEMA 12 control panel
- Single point electrical connection: motor, controls
- Door safety switch
- Electro-mechanical timer
- LED indicator lights
- Easy-glide door
- Large stainless steel removable scrap screen
- Stainless steel frame, legs and feet
- Stainless steel front panel
- Manifold clean-out brush

OPTIONS

- Plastic 20" x 20" racks (plate or silver)





LT-40^s

Low Temperature Chemical Sanitizing Door Type Dishwasher

Capacity Per Hour	40 racks 640 dishes
Tank Capacity	1.02 gallons (40.8 GPH)
Motor Size	1 hp (wash)
Electrical Usage	115V
Chemical Sanitizing	
Water Temperature (°F/°C)	
Minimum Wash Temperature	120/49
Minimum Rinse Temperature	120/49
Incoming Water Temperature	120/49
Other Water Requirements	
Water Flow Pressure (PSI)	15
Flow Rate Minimum	1.02
Water Line Size	1/2
Drain Line Size	2.0
Minimum Chlorine Required (PPM)	50
Shipping Weight	300 lbs.
Current Draw Amps	
115/1/60	
230/1/60	

SPECIFICATIONS

CONSTRUCTION- Hood and tank constructed of 16 gauge type 304 S/S. Hood unit of all welded seamless construction. S/S frame, legs and feet. All internal castings are non-corrosive lead free nickel alloy or bronze.

DOORS- Three (both sides and front) simultaneously opening doors. Operating doors have fingertip control, balanced by externally mounted springs. (Corner installations have two simultaneously opening doors at right angles.) All doors have easy-glide strips. Extra large die formed type 304 S/S doors ride in all S/S channels. A triple ply leading edge on the door channels made of S/S.

PUMP- Centrifugal type “packless” pump with a brass petcock drain. Construction includes ceramic seal and a balanced cast impeller on a precision ground stainless steel shaft, extension or sleeve. All working parts mounted as an assembly and removable as a unit without disturbing pump housing. One 1 hp motor, standard horizontal C-face frame, drip proof, internally cooled with ball-bearing construction.

CONTROLS- Top mounted control cabinet, NEMA 12 rated, housing motor controls and overload protection, transformer, contactors and all dishwasher integral controls. Integrated rack sensing system.

SPRAY SYSTEM- Wash and rinse spray systems made of stainless steel 300 series thread into cast hub assemblies. Upper and lower spray system assemblies are easily removeable.

WASH- 1 power spinning wash arm from below spray system and one from above. On both, the wash arm is designed with 7 slots. The slots are precision milled for water control and produce a fan spray.

DRAIN- Drain valve internally controlled. Overflow tube is removable without the use of tools for drain line inspection.

Contact Insinger Sales at 800-344-4802 for an installation drawing specific to your application.
This drawing is available on the Insinger website at www.insingermachine.com

Note: Due to product improvement we reserve the right to change information and specifications without notice.



ESSENTIAL SERIES

Project _____
Item _____
Quantity _____
CSI - 11400 _____
Approval _____
Date _____

LT-40^H

Low Temperature Chemical Sanitizing Extra High Door Type Dishwasher

- Automatic door type, single tank dishwasher with timed detergent, sanitizer, and rinse cycle
- 1.62 gallon/rack
- Capacity is 40 (20" x 20") racks per hour or 640 dishes per hour
- Field convertible from straight through to corner

STANDARD FEATURES

- SureFire® Start-Up & Check-Out Service
- Non-proprietary commercially available pump and parts
- "Easy Clean" front-mounted wash tank
- 1 HP 3500 RPM Pump Motor, GPM 55 @20 PSI
- Top-mounted NEMA 12 control panel
- Single point electrical connection: motor, controls
- Electro-mechanical timer
- LED indicator lights
- Easy-glide door
- Large stainless steel removable scrap screen
- Stainless steel frame, legs and feet
- Stainless steel front panel
- Manifold clean-out brush

OPTIONS

- Plastic 20" x 20" racks (plate or silver)





LT-40^H

**Low Temperature Chemical Sanitizing
Extra High Door Type Dishwasher**

Capacity Per Hour	40 racks 640 dishes meals
Tank Capacity	1.62 gallons (64.8 GPH)
Motor Size	1 hp (wash)
Electrical Usage	115V
Chemical Sanitizing	
Water Temperature (°F/°C)	
Minimum Wash Temperature	120/49
Minimum Rinse Temperature	120/49
Incoming Water Temperature	120/49
Other Water Requirements	
Water Flow Pressure (PSI)	20
Flow Rate Minimum	1.62
Water Line Size	1/2
Drain Line Size	2.0
Minimum Chlorine Required (PPM)	50
Shipping Weight	350 lbs.
Current Draw Amps	
115/1/60	
230/1/60	

SPECIFICATIONS

CONSTRUCTION- Hood and tank constructed of 16 gauge type 304 S/S. Hood unit of all welded seamless construction. S/S frame, legs and feet. All internal castings are non-corrosive lead free nickel alloy or bronze.

DOORS- Three (both sides and front) simultaneously opening doors. Operating doors have fingertip control, balanced by externally mounted springs. (Corner installations have two simultaneously opening doors at right angles.) All doors have easy-glide strips. Extra large die formed type 304 S/S doors ride in all S/S channels. A triple ply leading edge on the door channels made of S/S.

PUMP- Centrifugal type “packless” pump with a brass petcock drain. Construction includes ceramic seal and a balanced cast impeller on a precision ground stainless steel shaft, extension or sleeve. All working parts mounted as an assembly and removable as a unit without disturbing pump housing. One 1 hp motor, standard horizontal C-face frame, drip proof, internally cooled with ball-bearing construction.

CONTROLS- Top mounted control cabinet, NEMA 12 rated, housing motor controls and overload protection, transformer, contactors and all dishwasher integral controls. Integrated rack sensing system.

SPRAY SYSTEM- Wash and rinse spray systems made of stainless steel 300 series thread into cast hub assemblies. Upper and lower spray system assemblies are easily removeable.

WASH- 1 power spinning wash arm from below spray system and one from above. On both, the wash arm is designed with 7 slots. The slots are precision milled for water control and produce a fan spray.

DRAIN- Drain valve internally controlled. Overflow tube is removable without the use of tools for drain line inspection.

Contact Insinger Sales at 800-344-4802 for an installation drawing specific to your application.
This drawing is available on the Insinger website at www.insingermachine.com

Note: Due to product improvement we reserve the right to change information and specifications without notice.

**LT-40 LOW TEMPERATURE CHEMICAL
SANITIZING DOOR TYPE SERIES****INTRODUCTION**

This manual contains all pertinent information to assist in the proper installation, operation, cleaning, maintenance, and parts ordering for the LT-40S and LT-40H.

The installation instructions are intended for qualified equipment installers.

The operation and cleaning instructions are intended for the daily users of the equipment.

The maintenance and drawing sections are intended for qualified service and/or maintenance technicians.

Replacement parts may be ordered directly from our factory or from your local Authorized Insinger Service Company.

DEFINITIONS

Throughout this guide you will find the following terms: **WARNING, CAUTION, & NOTE.**

WARNING indicates potential physical danger.

CAUTION indicates potential equipment damage.

NOTE indicates helpful operating hints or tips.

You will visually be able to identify each as shown below:

**WARNING:**

Indicates potential physical danger.

CAUTION:

Indicates potential equipment damage.

**NOTE:**

Indicates helpful operating hints or tips.

SAFETY SUMMARY

The following are general safety precautions that are not related to any specific procedures. These are recommended precautions that personnel must understand and apply during many phases of operation and maintenance.

Keep Away From Live Circuits

Operating personnel must at all times observe all safety regulations. Do not replace components or make adjustments inside the equipment with the power supply turned on. Under certain conditions, dangerous potentials may exist when the power control is in the off position. To avoid casualties and injuries, always remove power, red tag and lockout machine, and ground a circuit before touching it.

Do Not Service or Adjust Alone

Under no circumstances should any person reach into or enter the enclosure for the purpose of servicing or adjusting the equipment except in the presence of someone who is capable of rendering aid.

Resuscitation

Personnel working with or near high voltages should be familiar with modern methods of resuscitation. Such information may be obtained from the Bureau of Medicine and Surgery.

INSINGER MACHINE COMPANY LIMITED WARRANTY

Insinger Machine Company, Inc. (Insinger) hereby warrants to the original retail purchaser of this Insinger Machine Company, Inc. product, that if it is assembled and operated in accordance with the printed instructions accompanying it, then for a period of either 15 months from the date of shipment from Insinger or 1 year (12 months) from the date of installation or start-up that said Insinger product shall be free from defects in material and workmanship. Whichever one of the two aforesaid limited warranty time periods is the shortest shall be the applicable limited warranty coverage time period.

Insinger may require reasonable proof of your date of purchase; therefore, you should retain your copy of invoice or shipping document.

This limited warranty shall be limited to the repair or replacement of parts which prove defective under normal use and service and which on examination shall indicate, to Insinger's satisfaction, they are defective. Any part that is claimed to be defective and covered by this limited warranty must be returned to Insinger. An RMA# must be obtained from the Insinger Warranty Department before returning any material. Return may be done through an Authorized Service Agency. Furnish serial number of machine and RMA # with shipment and send to:

Insinger Machine Company
6245 State Road
Philadelphia, PA 19135-2996

If Insinger's inspection confirms the defect and the claim, Insinger will repair or replace such part without charge and return it to you freight or postage prepaid.

This limited warranty does not cover any failure or accident, abuse, misuse, alteration, misapplication, improper installation, fire, flood, acts of God or improper maintenance or service, or failure

to perform normal and routine maintenance as set out in the instruction booklet (operating instructions) or for improper operation or failure to follow normal operating instructions (as set out in the instruction booklet). Insinger is not responsible nor liable for any conditions of erosion or corrosion caused by corrosive detergents, acids, lye or other chemicals used in the washing and or cleaning process.

Service must be done by either Insinger Appointed Service Agencies or agencies receiving prior authorization from Insinger.

All warranty work must be done during normal working hours, unless purchaser receives prior authorization from Insinger.

There are no other express warrants except as set forth herein and any applicable implied warranties of merchantability and fitness are limited in duration to the period of coverage of this express written limited warranty. This limited warranty supersedes all other express warranties, implied warranties of merchant-ability and fitness or limited warranties as of this date, January 1, 1998. Some states do not allow limitation on how long an implied warranty lasts so this limitation may not apply to you.

Insinger is not liable for any special, indirect or consequential damages. Some states do not allow the exclusion or limitation of incidental or consequential damages, so this limitation nor exclusion may not apply to you.

Insinger does not authorize any person or company to assume for it any other obligation or liability in connection with the sale, installation, use, removal, return or replacement of its equipment: and no such representations are binding on Insinger.

**LT-40 LOW TEMPERATURE CHEMICAL
SANITIZING DOOR TYPE SERIES**
INSTALLATION INSTRUCTIONS

These installation instructions are intended for qualified equipment installers.

Placement

Carefully uncrate the machine. Take caution not to damage components which may be mounted on the top or sides of the machine.

Set the unit in place and adjust the feet to level the machine.

Tabling

Load and unload tables should be pitched towards the machine to return excess water into the machine.

Fasten the tables to the load and unload side of the machine. Most installations require fastening the turn-down lip of the dish tables to the side of the machine with flathead countersunk screws. The table design should provide horizontal clearance of 30" for servicing.

Electrical Connections

Connect electrical lines sized for the correct voltage, current and phase of the machine. These should agree with the machine requirements indicated on the nameplate and labels on the control panel.

A single-point electrical connection is provided for the pumps, and control circuit. A laminated wiring diagram is inside the control panel.

CAUTION:

Connections must be made to a circuit breaker or fused disconnect as provided by the end-user and required by local codes.

LT-40S ELECTRICAL CHARACTERISTICS

VOLTS	115	230
PHASE	1	1
FREQUENCY	60	60
WASH MOTOR AMPS	13A	7A
TOTAL LOAD	13A	7A

LT-40H ELECTRICAL CHARACTERISTICS

VOLTS	115	230
PHASE	1	1
FREQUENCY	60	60
WASH MOTOR AMPS	13A	7A
TOTAL LOAD	13A	7A

Mechanical Connections

All lines must be flushed prior to use to remove debris. Connect water line for tank fill as tagged and noted on the installation drawings.

Connect the drain line. Drain lines must be as specified on installation drawings.

Drain line should be properly vented and should have a fall of not less than 1/4" to the foot of proper flow.

CAUTION:

Some area plumbing codes require drains to flow into an open gap with an opening twice the diameter of the pipe. Check with your local plumbing codes for the type of drain connection required.

CAUTION:

Do not reduce the size of lines as specified in installation drawings. All lines are sized to facilitate necessary flows, pressures, etc.

Chemical Supplies

The LT-40 control box is provided with detergent, rinse aid and sanitizer chemical feeder pumps. Each pump is equipped with a supply tube which has a stiffener tube attached at the end. Place the chemical container such as detergent, rinse aid, and sanitizer in a place where the stiffener tube can appropriate them. Insert each individual supply tube into each chemical container.

Red Supply Tubing = Detergent

Blue Supply Tubing = Rinse Aid

White Supply Tubing = Sanitizer

Pump Priming Instructions

When all the chemical tubes are connected correctly, follow the below procedure to prime the pumps:

1. Close the doors and turn the MAIN POWER switch to the ON position.
2. Press and hold the FILL button to fill the tank with water.
3. The detergent, rinse aid, and sanitizer PRIME switches are located on the control box beneath each pump. To prime each pump, press and hold the PRIME switch until the chemical has entered the sump. This can be verified by opening the doors slightly.
4. Once complete, close the doors and run one empty cycle.
5. At the end of the cycle, press and hold the DRAIN button to empty the tank.
6. Turn the MAIN POWER switch to the OFF position. Open the doors. The machine is now ready to use.

Setting Chemical Volumes

Your chemical supplier will be able to provide you with the appropriate chemicals to meet your needs.

The supplier will also be able to tell you the correct volume of each chemical required per cycle.

The chemical pumps have a flow rate of 1.95 mL per rotation with 22 rpm. You can set the fill volume of the sanitizer, detergent and rinse aid by adjusting the right side of CAMs 5,6, and 7 respectively.

The chlorine concentration in the wash tank must be at least 50 ppm. To verify this, follow these steps:

1. Close the doors and turn the MAIN POWER switch to the ON position.
2. Press and hold the FILL button to fill the tank with water.
3. Open the doors and wait for 10 seconds. Close the doors to start a cycle.
4. At the end of the cycle turn the MAIN POWER switch to the OFF position and open the doors.
5. Using a chlorine titration kit, measure the concentration of chlorine in the tank.
6. If necessary, adjust the right side of CAM 5 to ensure the concentration is at least 50 ppm.

Setting Water Fill Volume

Before washing ware ensure that CAM 4 is set for the correct fill volume:

1. Close the doors and turn the MAIN POWER switch to the ON position.
2. Press and hold the FILL button to fill the tank with water.
3. Open the doors and wait for 10 seconds. Close the doors to start a cycle.
4. At the end of the cycle turn the MAIN POWER switch to the OFF position and open the doors.
5. Verify that the water level is between the two lines on the drain stopper pipe. If not adjust the right side of CAM 4 and run another cycle.

CAM TIMER SETTINGS

CAM 1 is used for the cycle/reset control.

The CAM is NOT adjustable and is activated by the door switch. When machine is on, the CAM will stay idle until the door is open. It will then move to start position. Once the door is closed, the CAM powers the timer motor and the cycle starts.

CAM 2 controls the wash and rinse cycle timing.

The CAM is NOT adjustable and controls the power to the water pump motor. The pump will be energized when the contact is open. The CAM switch will open just after the door is closed, energizing the pump motor for the wash cycle. The CAM switch then drops into the notch, de-energizing the pump motor. After the dwell period, the CAM will energize the pump motor for the rinse cycle.

CAM 3 controls the drain solenoid timing.

The CAM is adjustable and controls the power to the drain solenoid. The drain solenoid is energized and water will be drained when the contact is open. The left side of the CAM is set to activate the drain solenoid just before the water pump is de-energized at the end of the wash cycle. Drain time can be controlled by adjusting the right side of the CAM.

CAM 4 controls the fill solenoid timing.

The CAM is adjustable and controls the power to the fill solenoid. The fill solenoid is energized and allows water to fill when the contact is closed. The CAM may need to be adjusted according to different water pressures to obtain the required water level. The left side of the CAM is set to activate the fill valve just before the drain is de-energized. Water volume can be controlled by adjusting the right side of the CAM.

CAM 5 controls the sanitizer pump timing.

The CAM is adjustable and controls the power to the sanitizer pump. The sanitizer pump is energized and adds sanitizer into the tank when the contact is closed. The CAM may need to be adjusted according to accommodate water condition and type of chemical. The left side of the CAM is set to activate the sanitizer pump after the drain solenoid is de-energized. The sanitizer volume can be controlled by adjusting the right side of the CAM.

CAM 6 controls the detergent pump timing.

The CAM is adjustable and controls the power to the detergent pump. The detergent pump is energized and adds detergent into the tank when the contact is closed. The CAM may need to be adjusted to accommodate water condition and type of chemical. The left side of the CAM is set to activate the detergent pump after the water pump is energized for the wash cycle. The detergent volume can be controlled by adjusting the right side of the CAM.

CAM 7 controls the rinse aid pump timing.

The CAM is adjustable and controls the power to the rinse aid pump. The rinse aid pump is energized and adds rinse aid into the tank when the contact is closed. The CAM may need to be adjusted to accommodate water condition and type of chemical. The left side of the CAM is set to activate the rinse aid pump after the drain solenoid is de-energized. The rinse aid volume can be controlled by adjusting the right side of the CAM.

CAM 8 controls the cycle counter.

The CAM controls the power to the cycle counter. Towards the end of the cycle the counter is energized. This adds a cycle to the total count.

CAUTION:

Verify water fill level and chlorine concentration before washing ware.

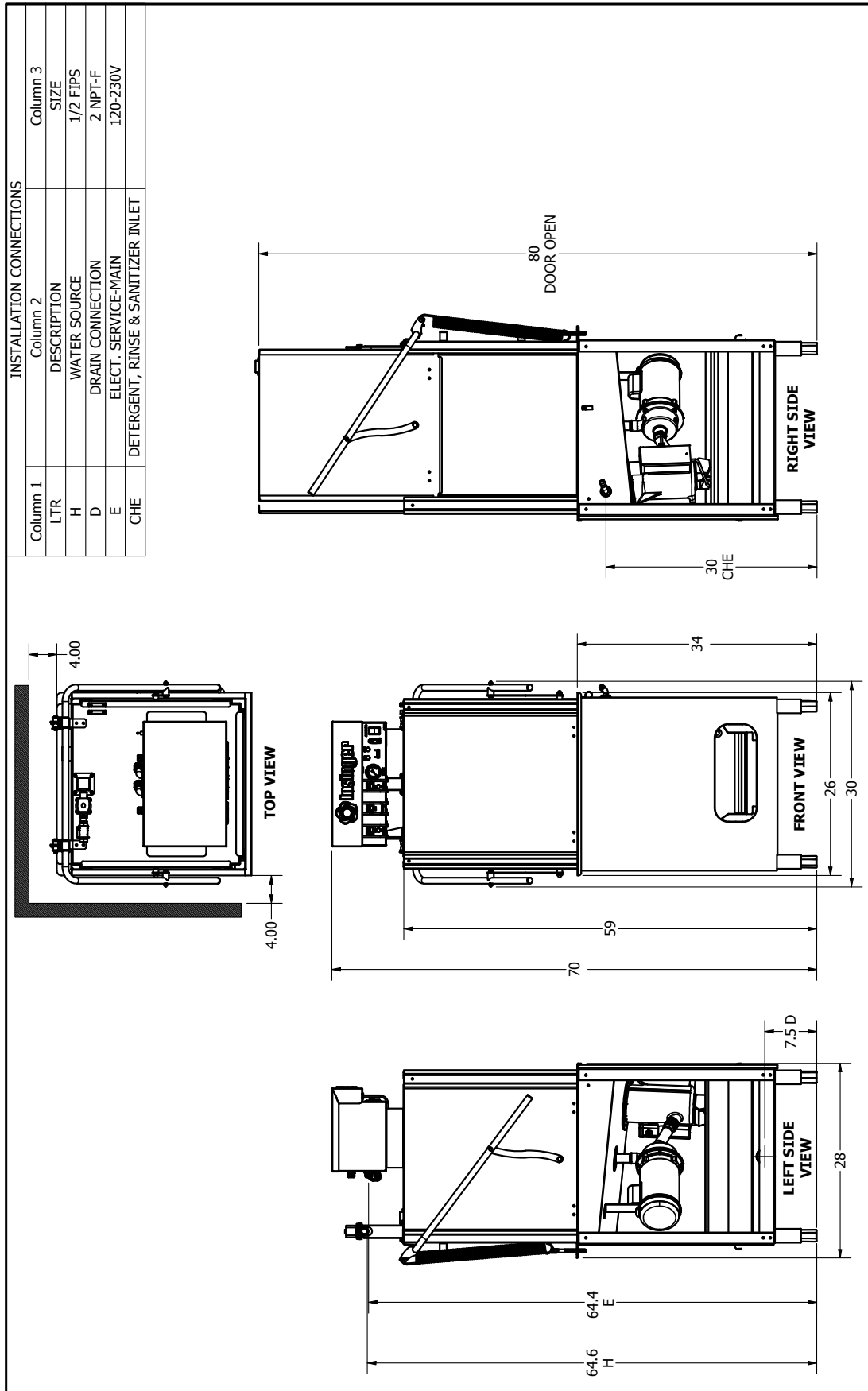

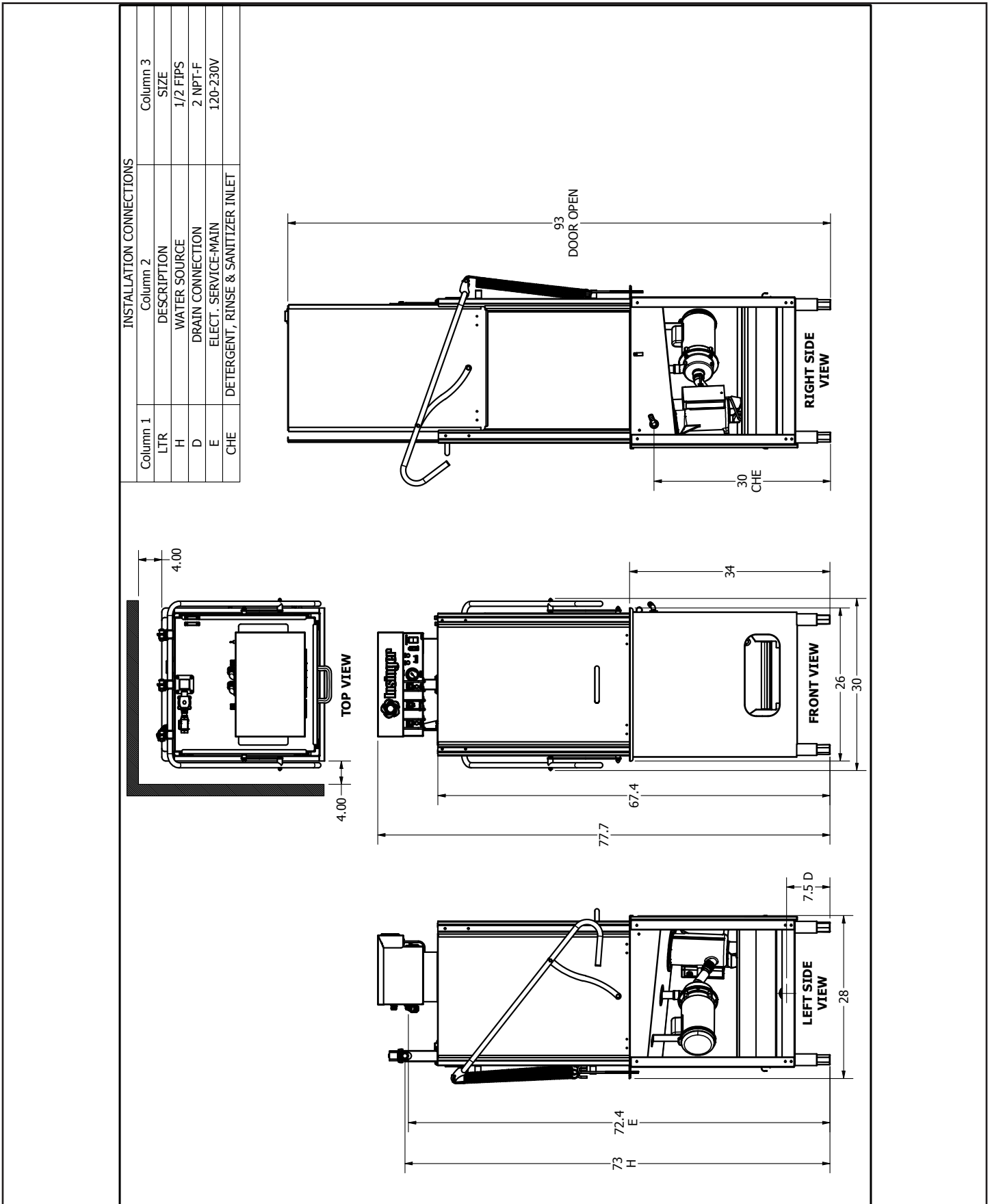

**LT-40 LOW TEMPERATURE CHEMICAL
SANITIZING DOOR TYPE SERIES**
OPERATION INSTRUCTIONS

These instructions are intended for the daily users of this machine.

PREPARING MACHINE

1. Ensure drain stopper pipe is in place to allow the tank to fill.
2. Check for proper installation and cleanliness of drain and sump strainers.
3. Ensure all water lines are open.
4. Ensure electrical circuits are on.
5. Check the chemical lines are connected to the correct chemical containers:
 - Red - detergent line
 - Blue - rinse aid line
 - White - sanitizer line

NOTE:

When using the machine for the first time or after replacing the chemical containers, ensure the pumps are primed. Refer to the **Pump Priming Instructions** in the **INSTALLATION INSTRUCTIONS** section.

STARTING MACHINE

1. Close the machine doors.

CAUTION:

Only turn the machine ON and OFF when the doors are fully closed.

2. Turn the MAIN POWER switch to the ON position. The POWER light will turn on to indicate the machine is on.
3. Press and hold the FILL button for approximately 10 seconds to fill the machine. Water will start to flow out of the drain when the tank is full.
4. Ensure that there are no major water leakages on the unit. Verify that the water level is between the two lines on the drain stopper pipe. The tank must be filled to the appropriate level before running a cycle.

WASHING A RACK

1. Open the doors. Insert a rack of soiled dishware into the machine.

CAUTION:

Overloading racks will minimize the proper cleaning of the ware.

2. Close the doors to run a cycle automatically. The CYCLE light will be on while the cycle is running.
3. When the CYCLE indicator light turns off, the machine cycle is complete.
4. Open the doors and remove the rack of clean ware. For the first rack, check the water level is between the two lines on the drain stopper pipe. If not refer to **CAM TIMER SETTINGS**.
5. Insert a new soiled rack and close the doors to run another cycle.

WARNING:

Wash tank water will be hot and hot water may be dripping from the doors.

WARNING:

Do not open the doors during the cycle as hot water is being sprayed. A switch is provided to stop the cycle if the doors are opened, but hot water may spray out if doors are opened too quickly.

SHUTDOWN

1. Remove your final rack of clean ware. Close the doors to run an empty cycle.
2. Once the cycle has finished (the CYCLE indicator light will be off), press and hold the DRAIN button to empty the tank.
3. Turn the MAIN POWER switch to the OFF position. The POWER light will turn off.
4. Refer to the CLEANING PROCEDURES for proper clean-up of the dishmachine.
5. Report any unusual occurrences to qualified service personnel.

**LT-40 LOW TEMPERATURE CHEMICAL
SANITIZING DOOR TYPE SERIES****CLEANING INSTRUCTIONS****DAILY CLEANING**

1. Remove and clean drain stopper pipe.
2. Once the tank is drained, remove the sump and drain strainers. Flush the strainers.
3. Remove the wash arms. Remove the endcaps and flush the wash arms. Ensure all nozzles are clear of matter.
4. Leave doors open to allow drying of interior surfaces.

WEEKLY CLEANING

1. The entire machine should be wiped down using a commercial foodservice stainless steel cleaner. Do not use steel wool.
2. Under the supervision of your detergent supplier the machine interior must be properly delimed. Refer to the **DELIME INSTRUCTIONS**.

DELIME INSTRUCTIONS

1. Disconnect the chemical feeder pumps.
2. While the doors are closed turn MAIN POWER switch to the ON position.
3. Press and hold the FILL button for approximately 10 seconds to fill the tank.
4. While the doors are closed turn MAIN POWER switch to the OFF position.
5. Fill the dishwasher with the correct amount of delime solution as recommended by the manufacturer of the chemicals.
6. Close the doors. Turn the MAIN POWER switch to the ON position.
7. Flip the DELIME switch to the DELIME position. This will cause the machine to run continuously.

**NOTE:**

The DELIME switch is located on the back of the control box.

7. Run the machine for the recommended length of time.
8. Flip the DELIME switch to NORMAL.
9. Press and hold the DRAIN button to empty the tank.
10. Turn the MAIN POWER switch to the OFF position.
11. Open the doors and step away for 5 minutes.
12. Inspect interior of the unit for lime deposit. If the results do not meet expectations, repeat steps 2 to 11.
13. Close the doors and turn the MAIN POWER switch to the ON position.
14. Refill the unit by holding the FILL button for approximately 10 seconds.
15. Flip the DELIME switch to the DELIME position and run the unit for 10 minutes.
16. Flip the DELIME switch to the NORMAL position.
17. Press and hold the DRAIN button to empty the tank.
18. Turn the MAIN POWER switch to the OFF position.
19. Open the doors.
20. Reconnect the chemical feeder pumps.
21. The machine is ready to use.

**WARNING:**

Use of deionized water or other aggressive fluids will result in corrosion and failure of materials and components. Use of deionized water or other aggressive fluids will void the manufacturer's warranty.

**NOTE:**

The water quality in some areas requires deliming to be done more frequently. Contact your detergent supplier for recommended de-liming frequency.

**LT-40 LOW TEMPERATURE CHEMICAL
SANITIZING DOOR TYPE SERIES****MAINTENANCE REQUIREMENTS**

This section is intended for qualified service and/or maintenance technicians.

The following maintenance should be conducted quarterly:

1. Remove and clean the strainer screens on the water lines. If the screens cannot be cleaned, replace.
2. Inspect the condition of the fill solenoid valve seats, and diaphragms. Replace as necessary.
3. Inspect drain stopper for leakage. Replace as necessary.
4. Check door spring tension and adjust as necessary.
5. Check wash arm bearing and replace as necessary.

MAINTENANCE PROCEDURES**Liner Strainer Disassembly**

1. Shut off water supply.
2. Remove large hex nut on bottom of strainer body.
3. Remove strainer screen. Inspect and clean or replace as necessary.
4. Reassemble in reverse of disassembly. Water flow must be same direction as arrow on line strainer body. Use new gaskets to insure a tight seal.

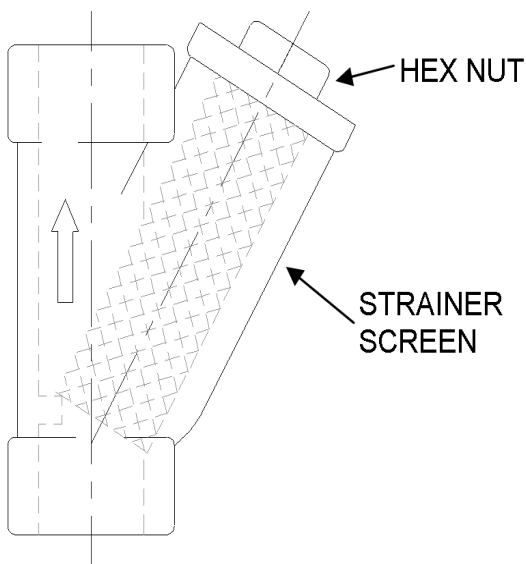
**Solenoid Valve Disassembly**

(See dwg. SK-5825)

1. Disconnect the power supply to the machine. Turn off the water supply.
2. Remove cap on top of the coil. Remove the coil.
3. Remove the 4 hex bolts and lift bonnet from valve body. Note positioning of spring and plunger.
4. Remove main piston.
5. Inspect for dirt, wear or lime build-up. Clean or replace as required.
6. Reassemble in reverse of disassembly.

Pump Disassembly

1. Before disassembling pump ensure there are no obstructions in the pump intake by removing and cleaning the sump strainer (inside tank).
2. Remove the pump motor and impellar by removing the 4 hex bolts attaching them to the pump housing.
3. Repair or replace the pump parts as required.
4. Reassemble in reverse of disassembly.

TROUBLESHOOTING

TECHNICAL ISSUES	POSSIBLE CAUSES	SOLUTIONS
Dishmachine will not start.	<ol style="list-style-type: none"> 1. Service disconnect switch is off or faulty. 2. Branch circuit breaker is tripped. 3. Electrical connections are loose or broken. 	<ol style="list-style-type: none"> 1. Make sure it is on. 2. Reset or replace the part. 3. Tighten or replace them.
Machine will not run in ON position or in DELIME mode.	Door switch, MAIN POWER switch or DELIME switch is defective.	Call the service technician.
Machine fills continuously even with no power applied to the machine.	Water inlet solenoid valve is allowing water into machine.	<ol style="list-style-type: none"> 1. Check the water pressure during fill, water pressure must be 15 psi. 2. Repair or replace the water inlet solenoid valve.
Machine runs continuously in the wash cycle.	<ol style="list-style-type: none"> 1. Check if machine is in DELIME mode. 2. Possible issues with CAM timer. 	<ol style="list-style-type: none"> 1. Flip the switch to NORMAL position. 2. Contact service technician.
Machine will not hold water.	<ol style="list-style-type: none"> 1. Drain stopper is in bad condition. 2. Obstructed drain hole. 3. Drain linkage is binding. 	<ol style="list-style-type: none"> 1. Replace the part. 2. Remove the obstruction from drain. 3. Repair damaged drain mechanism parts.
Machine will not fill, other functions works.	<ol style="list-style-type: none"> 1. Line strainer clogged. 2. Incoming water to unit is turned off. 3. Faulty MAIN POWER switch. 4. Faulty solenoid coil. 	<ol style="list-style-type: none"> 1. Refer to MAINTENANCE PROCEDURE for cleaning instruction. 2. Turn on water to the unit. 3. Replace the part. 4. If coil has voltage but no continuity, replace the solenoid.
Machine fills slowly and or the rinse is weak.	<ol style="list-style-type: none"> 1. Clogged or obstructed wash arms. 2. Low incoming water pressure. 3. Line strainer is clogged. 4. CAM 4 not set to correct fill time. 	<ol style="list-style-type: none"> 1. Remove and clean the arms. 2. Adjust water pressure to 15 psi. 3. Refer to MAINTENANCE PROCEDURE for cleaning instruction. 4. Adjust the right side of CAM 4 to increase fill time.
Water will not drain from the machine.	Drain solenoid and drain mechanism are faulty.	Call service technician.
Water leaks at wash pump.	Wash pump seal is defective.	Replace the part.
Dishes/Glasses are not clean.	<ol style="list-style-type: none"> 1. Machine temperatures are not up to the minimum requirements. 2. No detergent/too much detergent. 3. Dry food soil on ware. 	<ol style="list-style-type: none"> 1. Ensure that the incoming water meets the requirement listed on the machine data page. 2. Adjust the concentration as recommended by the chemical provider. 3. Pre-scrub moist food soil or pre-soak ware

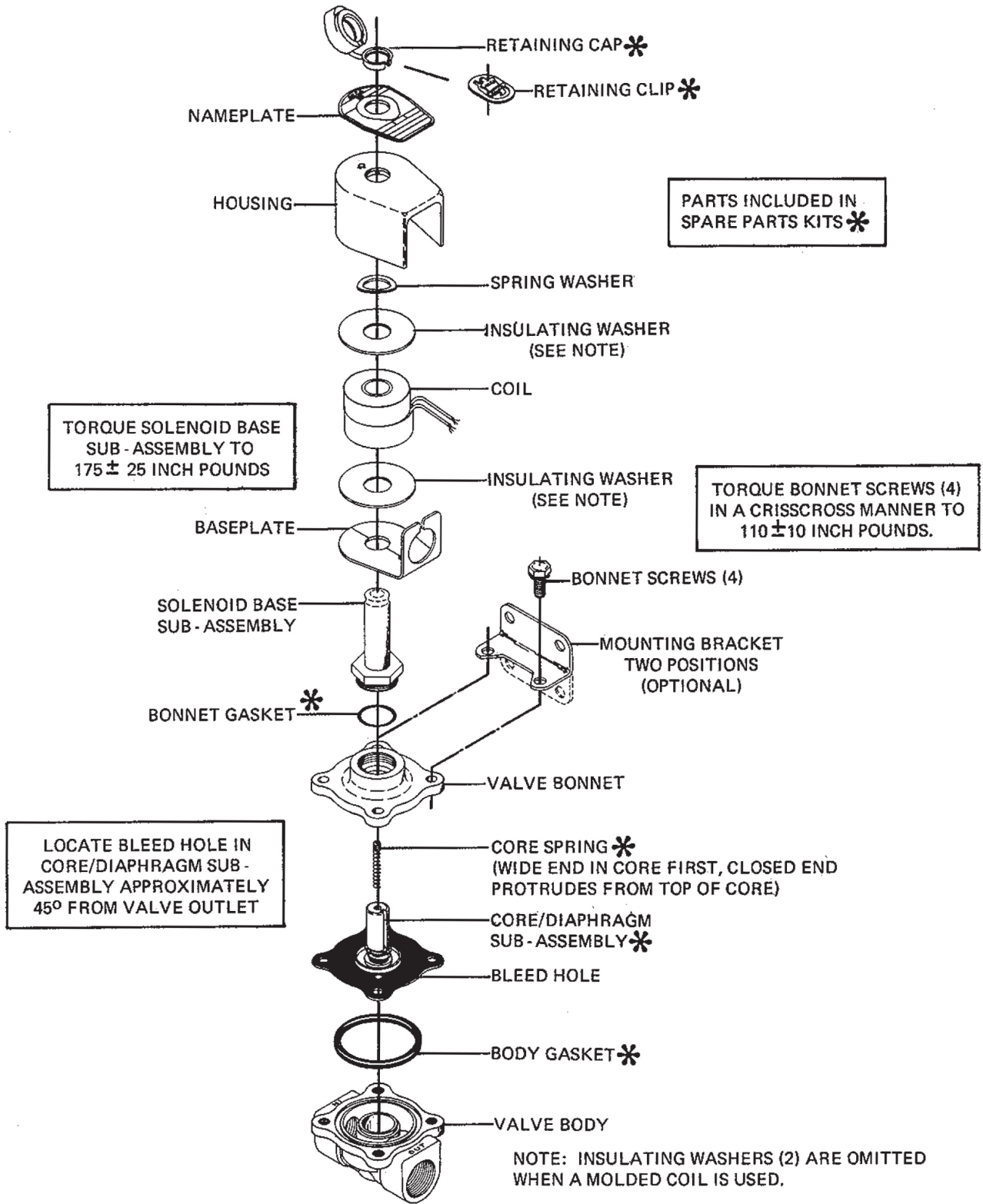

Solenoid Valve
Final Rinse
6-17

Sketch A/ SK-5825

**LT-40S 3/4HP Pump Motor
6110-00503**

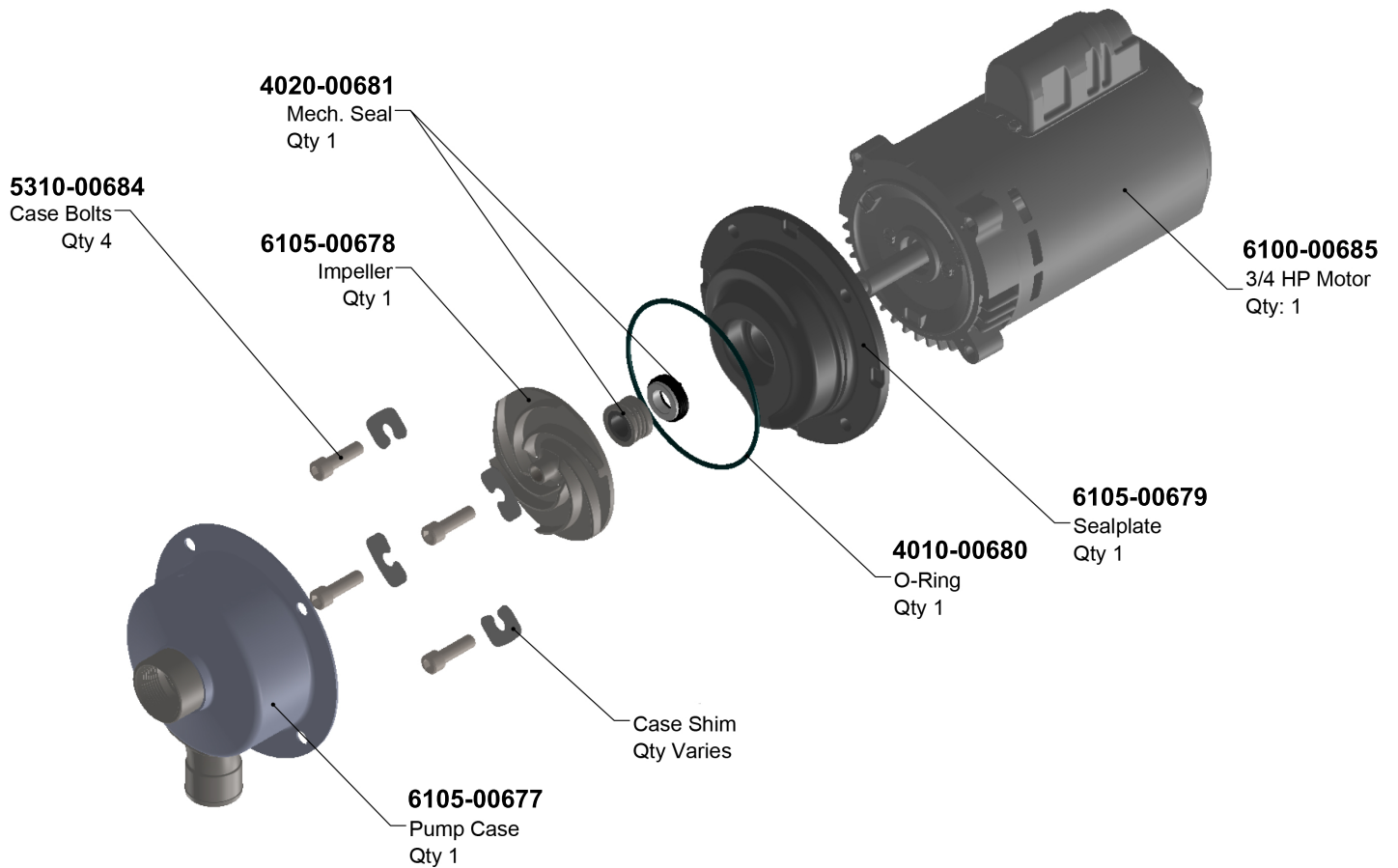

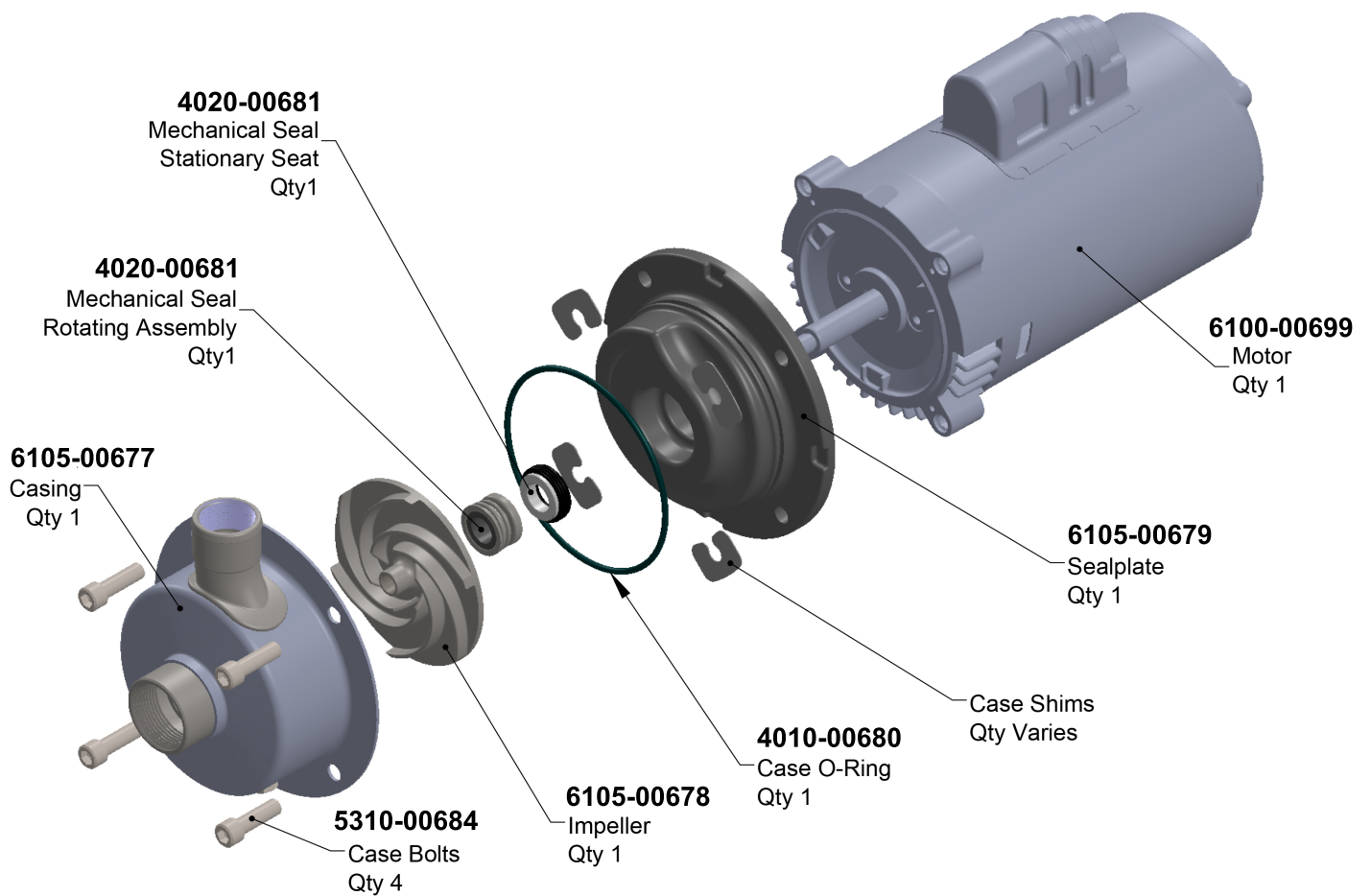
**LT-40H 1HP Pump Motor
6110-00698**

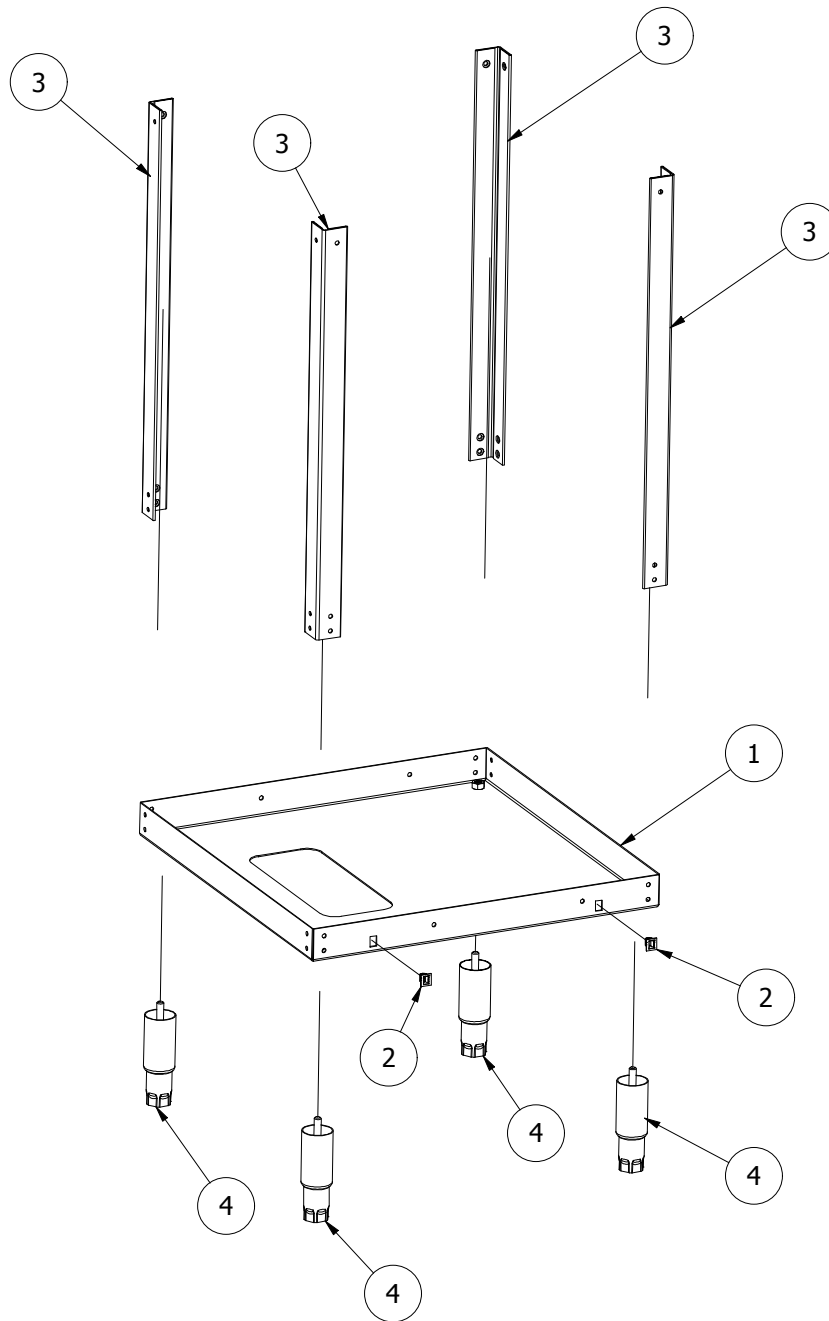
Base Frame Assembly

Item No.	Part No.	Description	Quantity
1	7100-00378	Base Pan Weldment	1
2	6320-00501	Fastener Latch	2
3	7000-00242	Vertical Support Leg	4
4	6310-00367	S/S Adjustable Foot	4

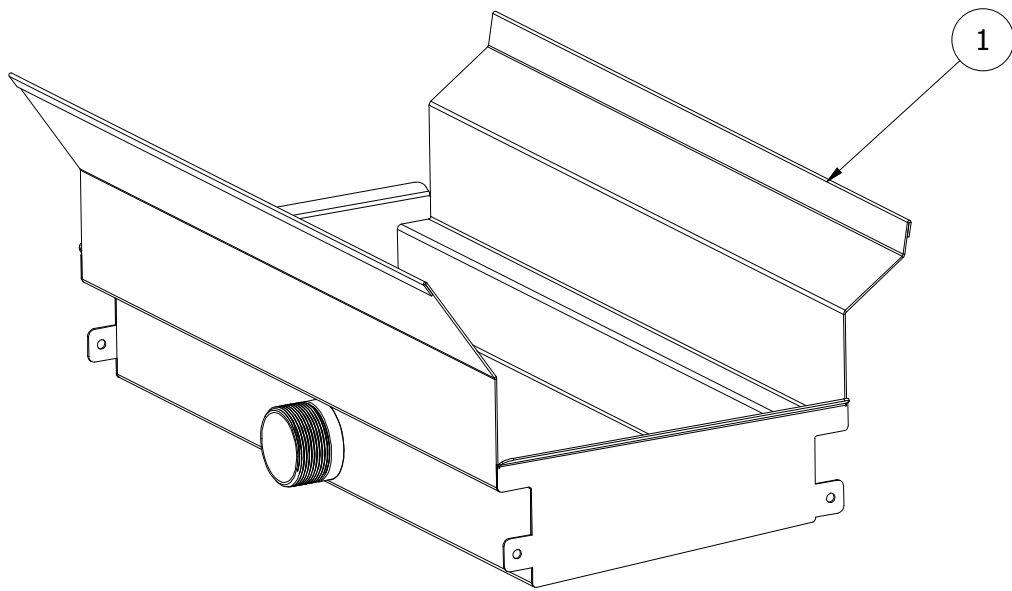
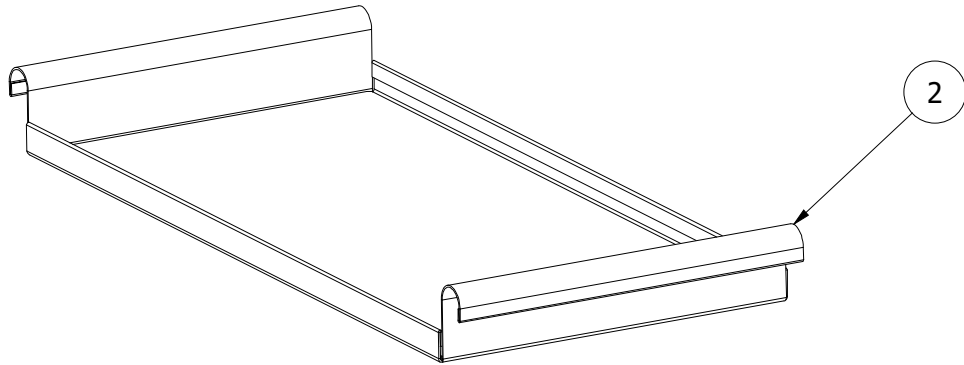
Drain Accumulator Assembly

Item No.	Part No.	Description	Quantity
1	7100-00517	Drain Accumulator Weldment	1
2	7100-00524	Drain Strainer Weldment	1

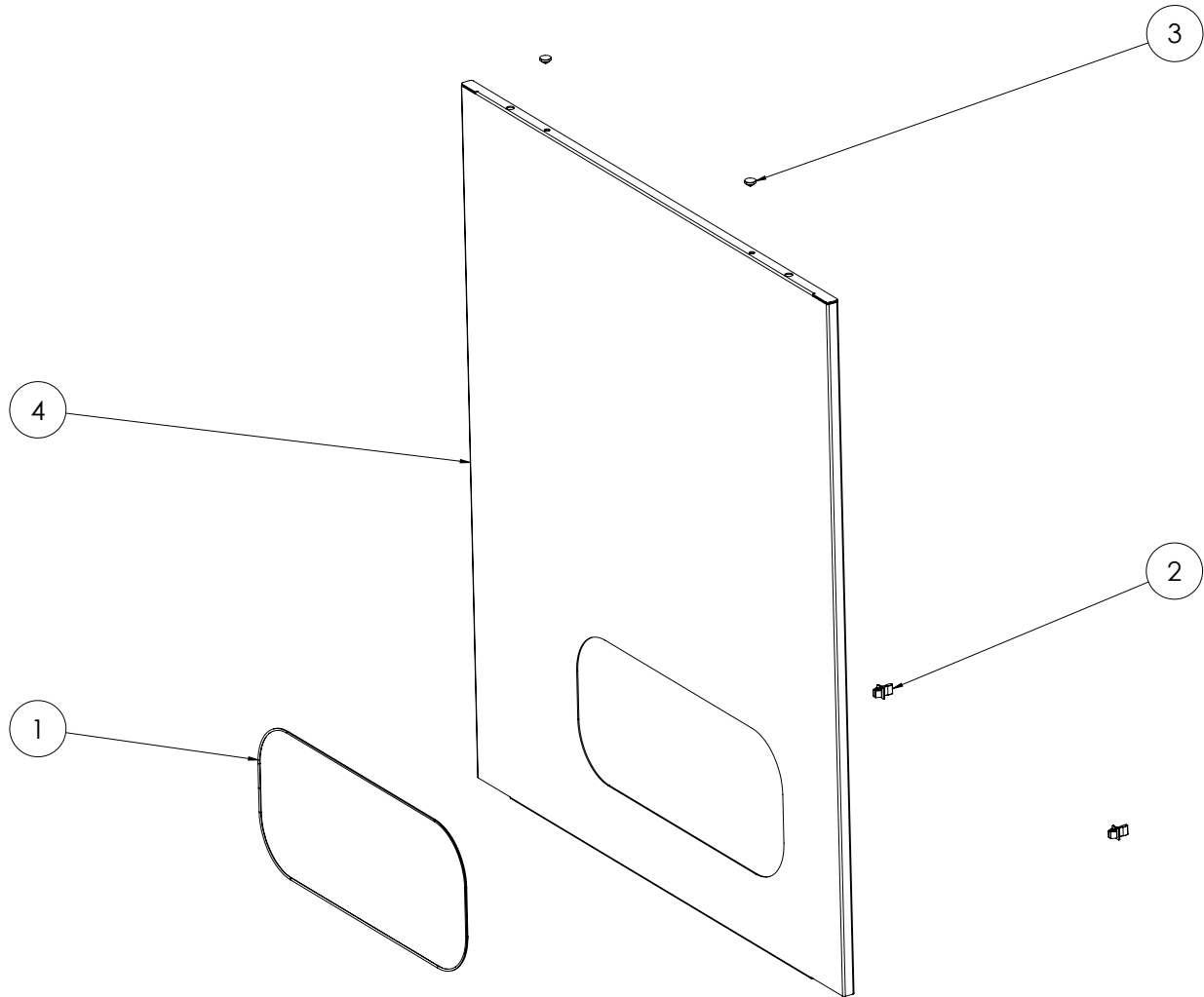
Access Panel Assembly

Item No.	Part No.	Description	Quantity
1	7500-00676	Edge Trim, 36.5" Length	1
2	6320-00500	Fastener Strike	2
3	6320-00502	Panel Bumper	2
4	7000-00267	Front Access Panel	1

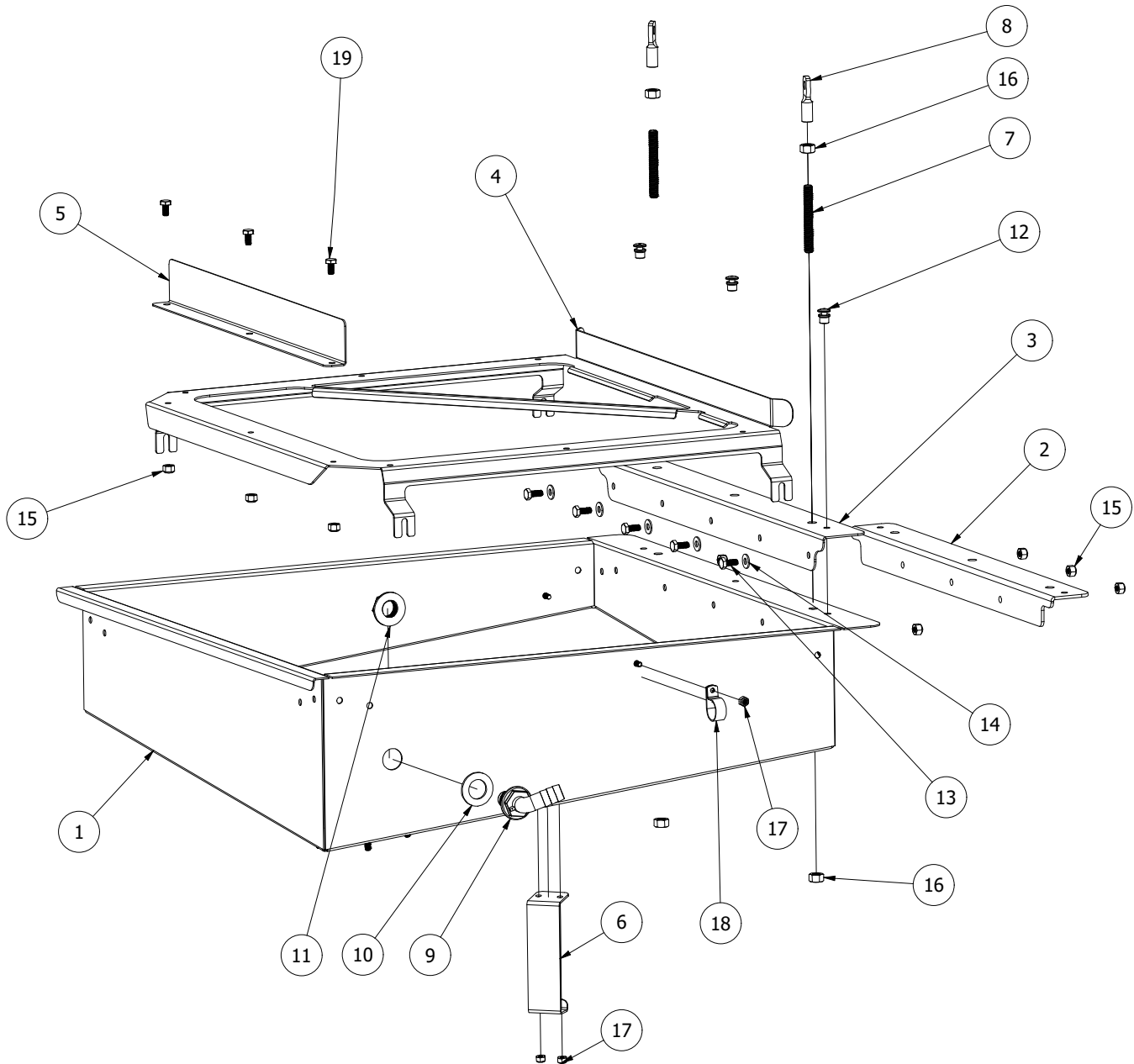
LT-40S Tank Assembly

Item #	Part No.	Description	Qty.
1	7100-00718	Tank Weldment	1
2	7000-00250	Bracket, Lower, Spring-Tank	1
3	7000-00249	Bracket, Upper, Spring-Tank	1
4	7000-00251	Rack Support	1
5	7000-00507	Rack Guard	1
6	7000-00487	Bracket, Motor	1
7	7000-00414	Threaded Rod, 3/8-16 X 6"	2
8	5315-00413	Eye Coupling, 3/8-16 thread	2
9	3100-00484	Chemical Pipe Guide	1
10	3100-00485	Chemical Pipe Guide Gasket	1

Item #	Part No.	Description	Qty.
11	3100-00486	Chemical Pipe Guide Nut	1
12	5310-00520	.25 Diameter x .25 Grip Huck Bolt	2
13	5310-00388	1/4-20 X 5/8 S/S Hex Bolt	5
14	5330-00391	1/4" S/S Flatwasher	7
15	5325-00392	1/4-20 S/S Coarse Locknut	8
16	5325-00553	3/8-16 S/S Hex Nut (Medium)	4
17	5325-00549	#10-32 S/S Fine Locknut	3
18	5515-00443	Loop Clamp, .50 Wide x .875 ID	1
19	5310-00387	1/4-20 X 1/2 S/S Hex Bolt	3

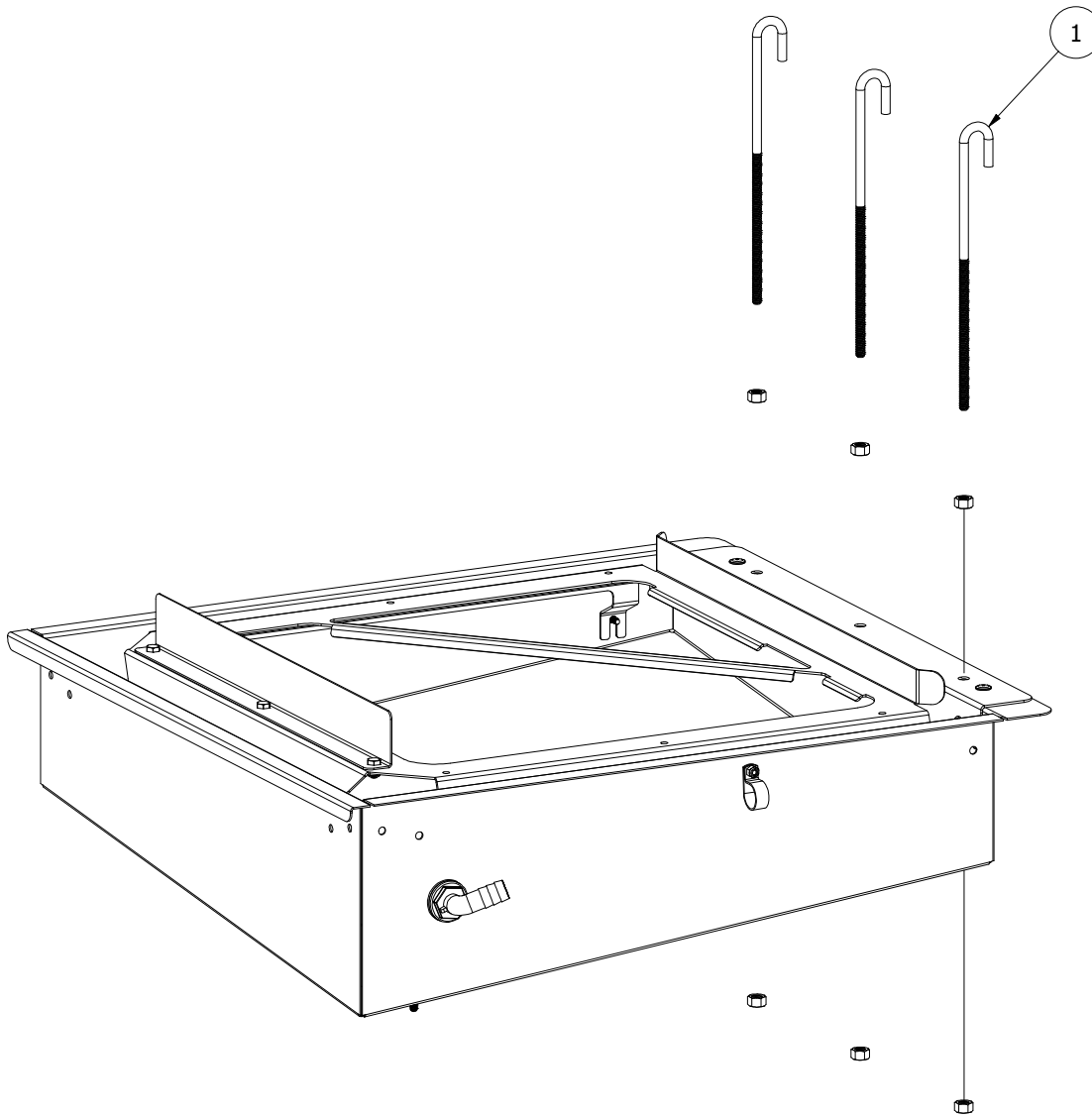
LT-40H Tank Assembly

Item No.	Part No.	Description	Quantity
1	5315-00464	Hook Bolt, 5/16" x 10-1/8"	3

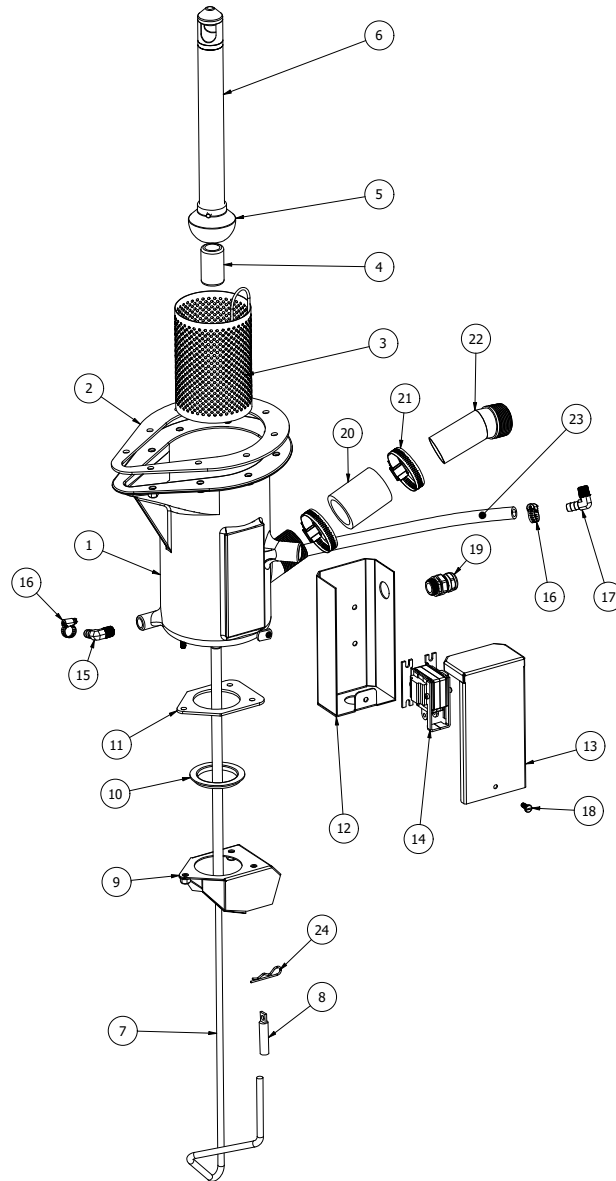
Sump Assembly

Item #	Part No.	Description	Qty.
1	3000-00352	Sump	1
2	4005-00353	Sump Gasket	1
3	7100-00441	Sump Strainer Weldment	1
4	7000-00275	Overflow Tube Guide	1
5	3100-00439	Rubber Drain Stopper	1
6	7100-00687	Overflow Tube, LT-40S	1
or	7100-00696	Overflow Tube, LT-40H	1
7	7000-00276	Pop Rod	1
8	7000-00277	Clevis Thread	1
9	7100-00437	Drain Channel Weldment	1
10	7000-00273	Drain Flange	1
11	4005-00438	Drain Channel Gasket	1
12	7100-00672	Drain Solenoid Box Weldment	1

Item #	Part No.	Description	Qty.
13	7000-00259	Drain Solenoid Cover	1
14	5935-00444	Drain Solenoid, 120V	1
15	4825-00471	Elbow, 3/8" Hose x 1/4" NPT	1
16	5375-00511	Hose Clamp, 7/32" to 5/8"	2
17	4825-00510	Elbow, 3/8" Hose x 1/8" NPT	1
18	5305-00394	Screw, 10-32 x 1/2" Pan Head	1
19	5915-00446	Connector, Liquid Tite 3/8"	1
20	7500-00472	Rubber Hose, 1.5" ID 2" OD	1
21	5375-00505	Hose Clamp, S/S 3/4" - 1-3/4"	2
22	7100-00401	Pump/Sump Fitting Weldment	1
23	7500-00564	Hose, PVC Braided 3/8" ID	1
24	5340-00440	Cotter Pin, 3/8" to 1/2" Dia.	1

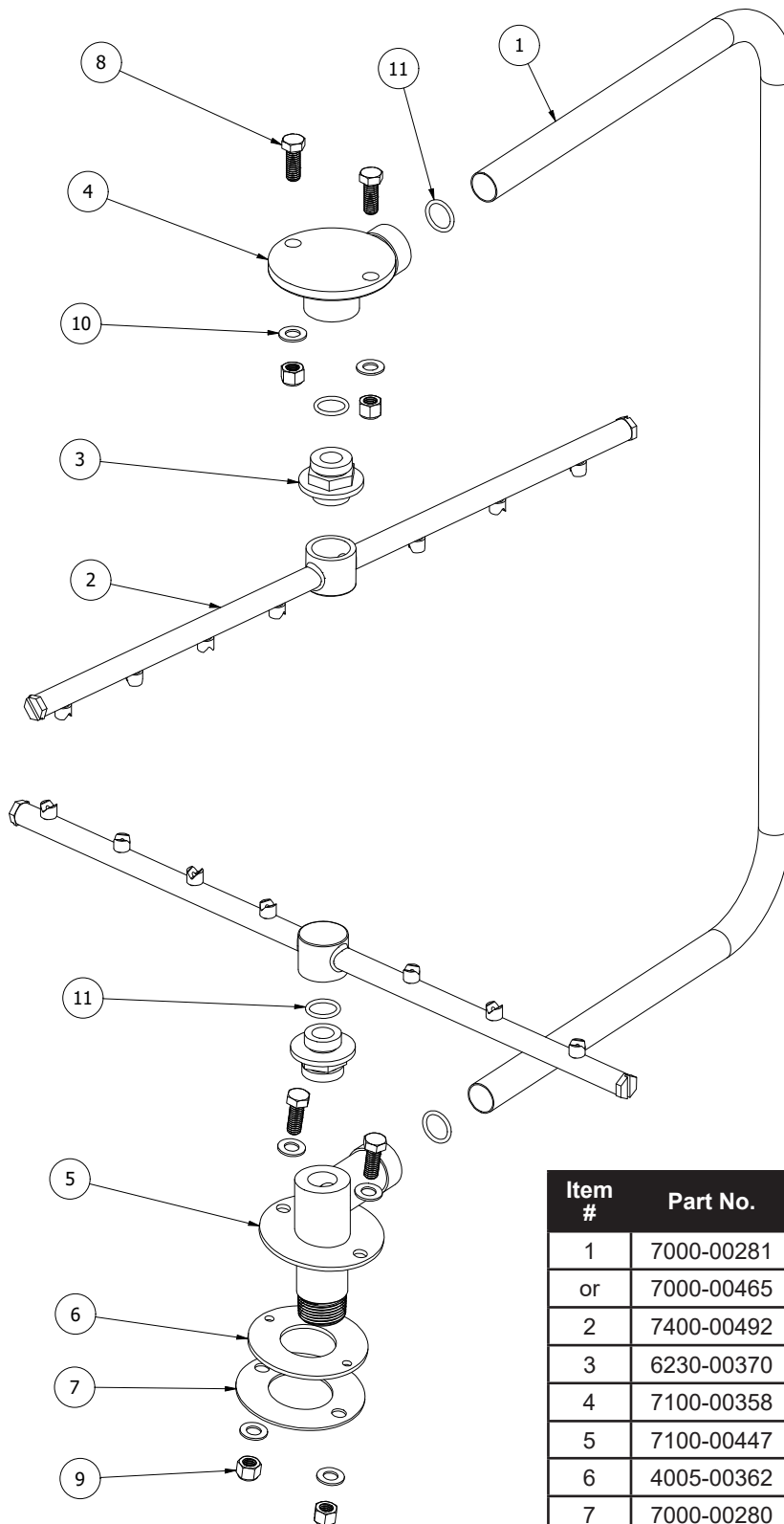
Spray Arm Assembly

Item #	Part No.	Description	Qty.
1	7000-00281	Discharge Tube, LT-40S	1
or	7000-00465	Discharge Tube, LT-40H	1
2	7400-00492	Spray Arm Assembly	2
3	6230-00370	Spray Arm Bearing	2
4	7100-00358	Upper Wash Manifold Weldment	1
5	7100-00447	Lower Wash Manifold Weldment	1
6	4005-00362	Lower Manifold Gasket	1
7	7000-00280	Lower Manifold Spacer Ring	1
8	5310-00523	3/8-16 X 1 S/S Hex Head Screw	4
9	5325-00539	3/8-16 S/S Locknut with Nylon	4
10	5330-00538	3/8" Diameter Washer	6
11	4010-00498	O-Ring, .94 OD .74 ID	4

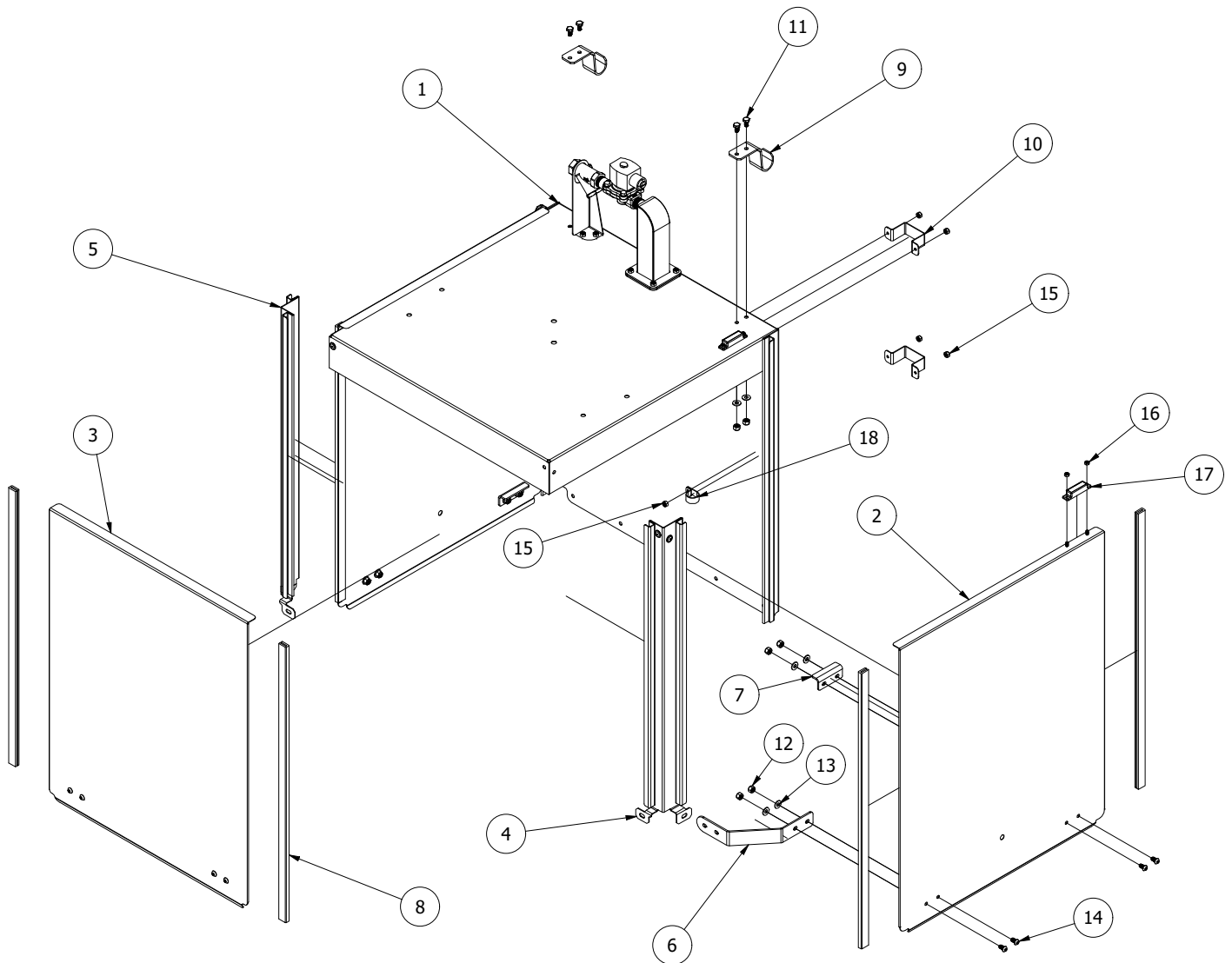
LT-40S Hood & Door Assembly

Item #	Part No.	Description	Qty.
1	7000-00241	Hood, LT-40S	1
2	7000-00253	Side Door, LT-40S	2
3	7000-00254	Front Door, LT-40S	1
4	7100-00674	Corner Post RH, LT-40S	1
5	7100-00673	Corner Post LH, LT-40S	1
6	7000-00255	Door Alignment Bracket, LT-40S	2
7	7000-00256	Door Stopper Bracket	2
8	7500-00442	Plastic Door Strips, 25"	6
9	7000-00257	Handle Pivot Bracket	2

Item #	Part No.	Description	Qty.
10	7000-00282	Cable Bracket	2
11	5310-00387	1/4-20 X 1/2 S/S Hex Bolt	4
12	5325-00392	1/4-20 S/S Locknut	16
13	5330-00391	1/4" S/S Flatwasher	16
14	5305-00519	1/4-20 X 1/2 Socket Screw	12
15	5325-00549	#10-32 Locknut S/S Fine	4
16	5325-00556	#6-32 Locknut Nylon S/S	4
17	5060-00445	Magnetic Door Switch	1
18	5515-00443	Loop Clamp, .50 Wide x .875 ID	1

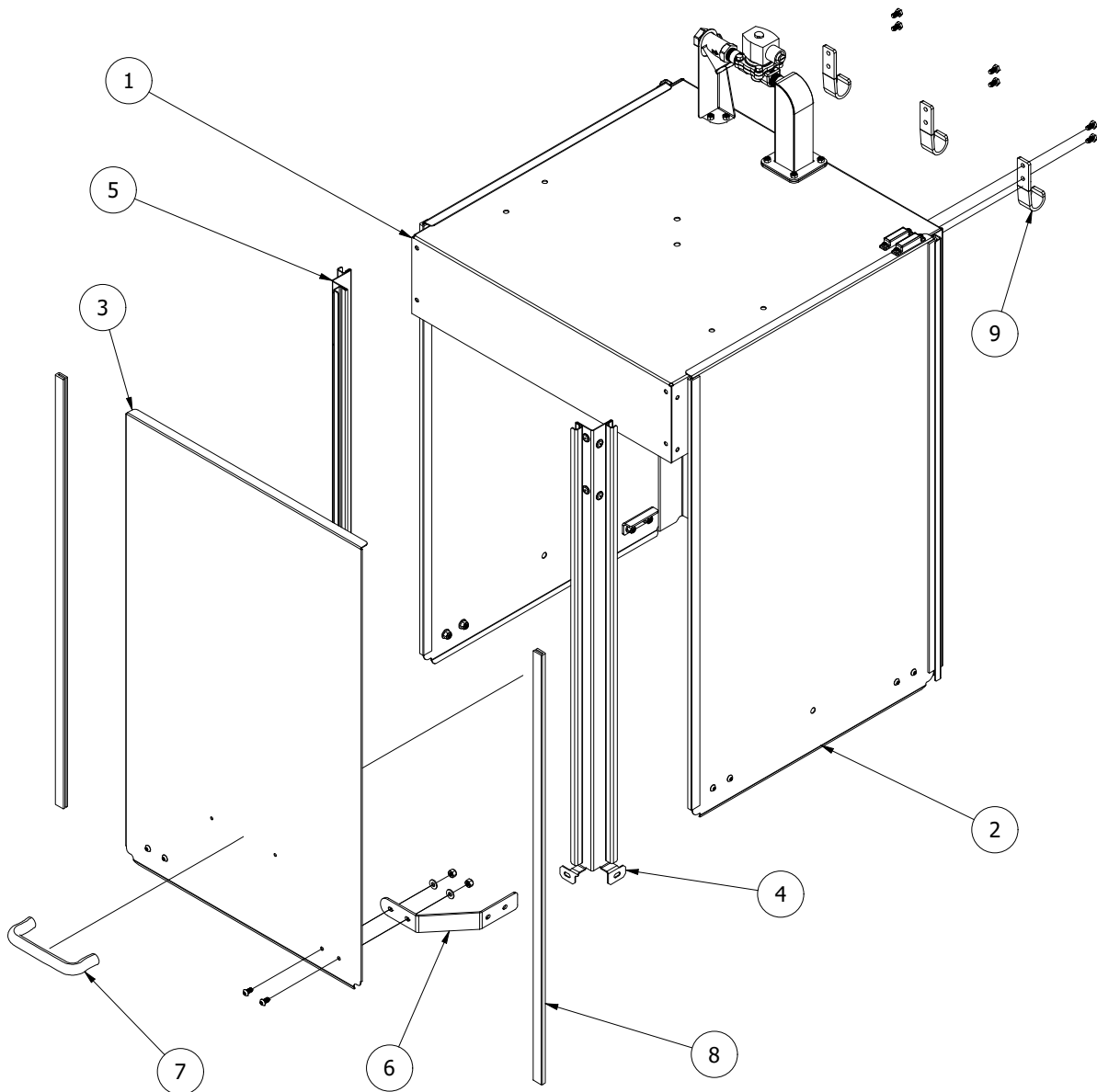
LT-40H Hood & Door Assembly

Item No.	Part No.	Description	Qty.
1	7000-00450	Hood, LT-40H	1
2	7000-00452	Side Door, LT-40H	2
3	7000-00451	Front Door, LT-40H	1
4	7100-00483	Corner Post RH, LT-40H	1
5	7100-00481	Corner Post LH, LT-40H	1
6	7000-00470	Door Alignment Bracket, LT-40H	2
7	6320-00458	Front Door Handle	1
8	7500-00457	Plastic Door Strips, 33"	6
9	7000-00459	Handle Pivot Bracket, High	3

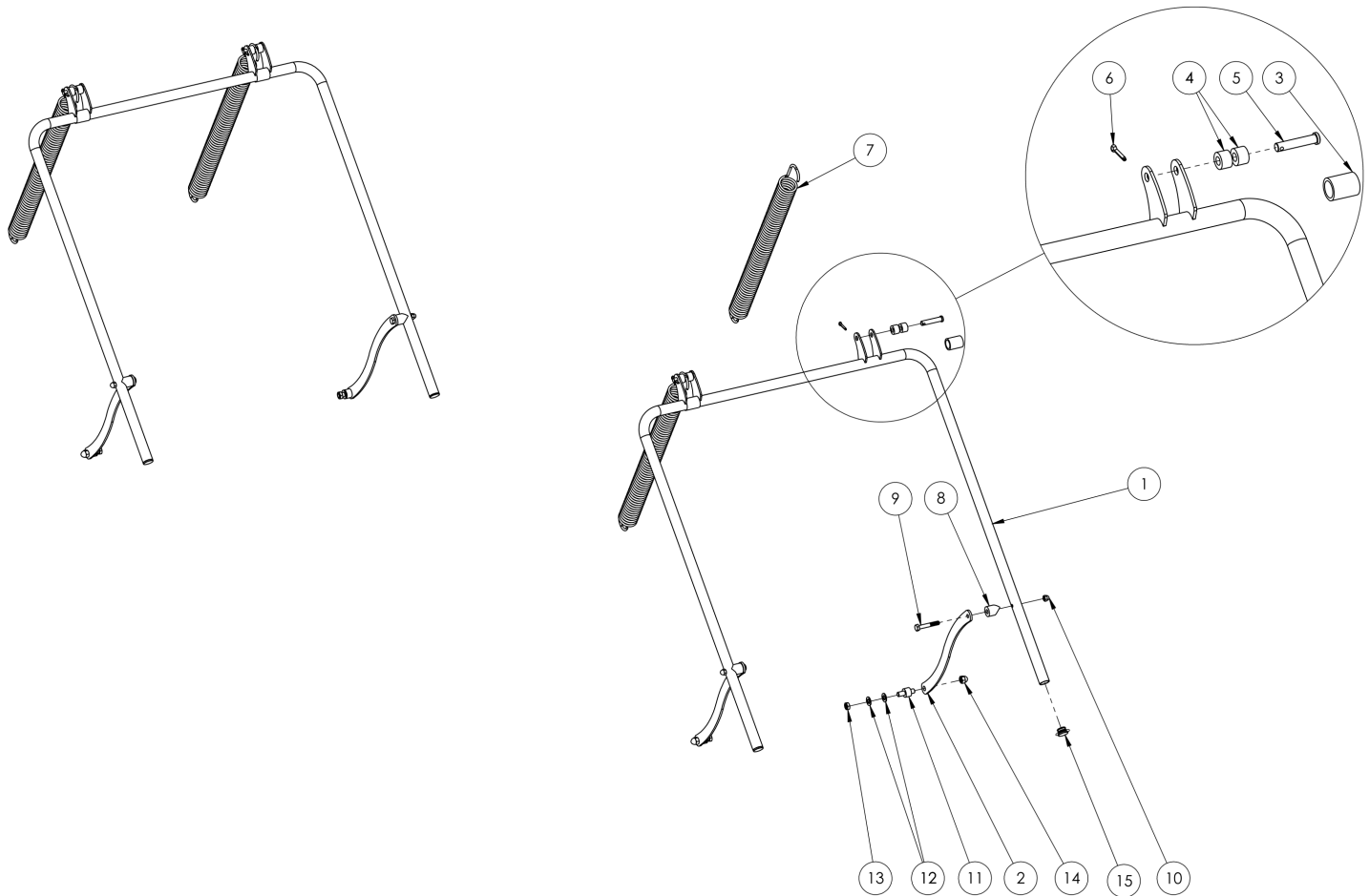
LT-40S Handle Assembly

Item No.	Part No.	Description	Qty.
1	7100-00406	Handle Bar Weldment	1
2	7000-00260	Handle Door Link	2
3	6235-00407	Plastic Bushing Sleeve	2
4	5335-00409	Unthreaded Spacer, .38" ID	4
5	5340-00408	Clevis Pin, .375"	2
6	5340-00411	Cotter Pin	2
7	5405-00410	Compression Helical Spring	2
8	7000-00357	Handle Link Spacer	2
9	5310-00550	1/4-20 X 2 S/S Hex Head Bolt	2
10	5325-00551	1/4-20 S/S Coarse Acorn Nut	2
11	5335-00363	Door Link Spacer with Thread	2
12	5330-00364	3/8" S/S Flatwasher	4
13	5325-00365	3/8-16 S/S Thin Sealnut with Nylon	2
14	5325-00552	3/8-16 S/S Coarse Acorn Nut	2
15	3900-00366	End Plugs	2

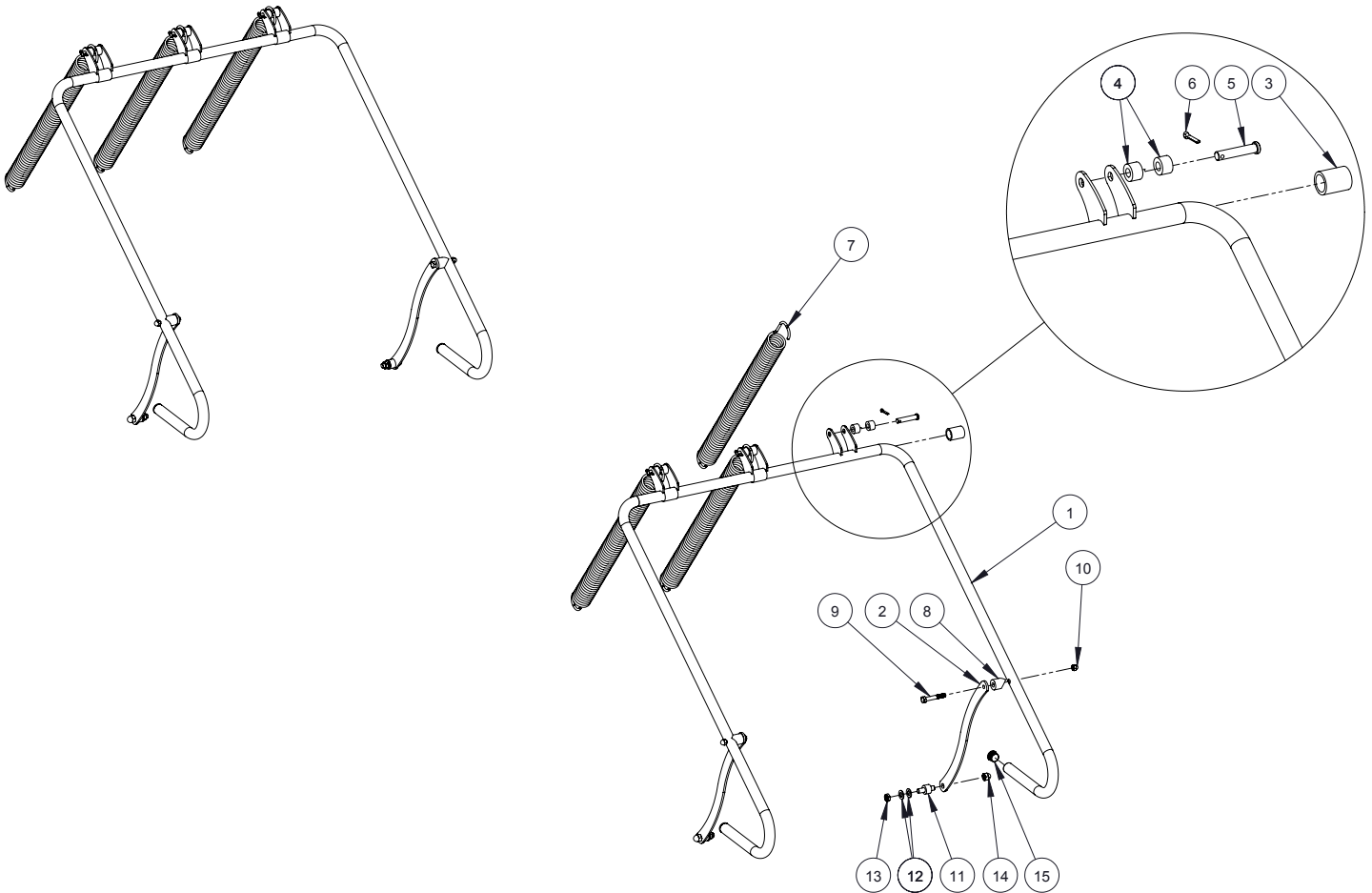
LT-40H Handle Assembly

Item No.	Part No.	Description	Qty.
1	7100-00463	Handle Bar Weldment (High)	1
2	7000-00461	Handle Door Link (High)	2
3	6235-00407	Plastic Bushing Sleeve	3
4	5335-00409	Unthreaded Spacer, .38" ID	6
5	5340-00408	Clevis Pin, .375"	3
6	5340-00411	Cotter Pin	3
7	5405-00410	Compression Helical Spring	3
8	7000-00357	Handle Link Spacer	2
9	5310-00550	1/4-20 X 2 S/S Hex Head Bolt	2
10	5325-00551	1/4-20 S/S Coarse Acorn Nut	2
11	5335-00363	Door Link Spacer with Thread	2
12	5330-00364	3/8" S/S Flatwasher	4
13	5325-00365	3/8-16 S/S Thin Sealnut with Nylon	2
14	5325-00552	3/8-16 S/S Coarse Acorn Nut	2
15	3900-00366	End Plugs	2

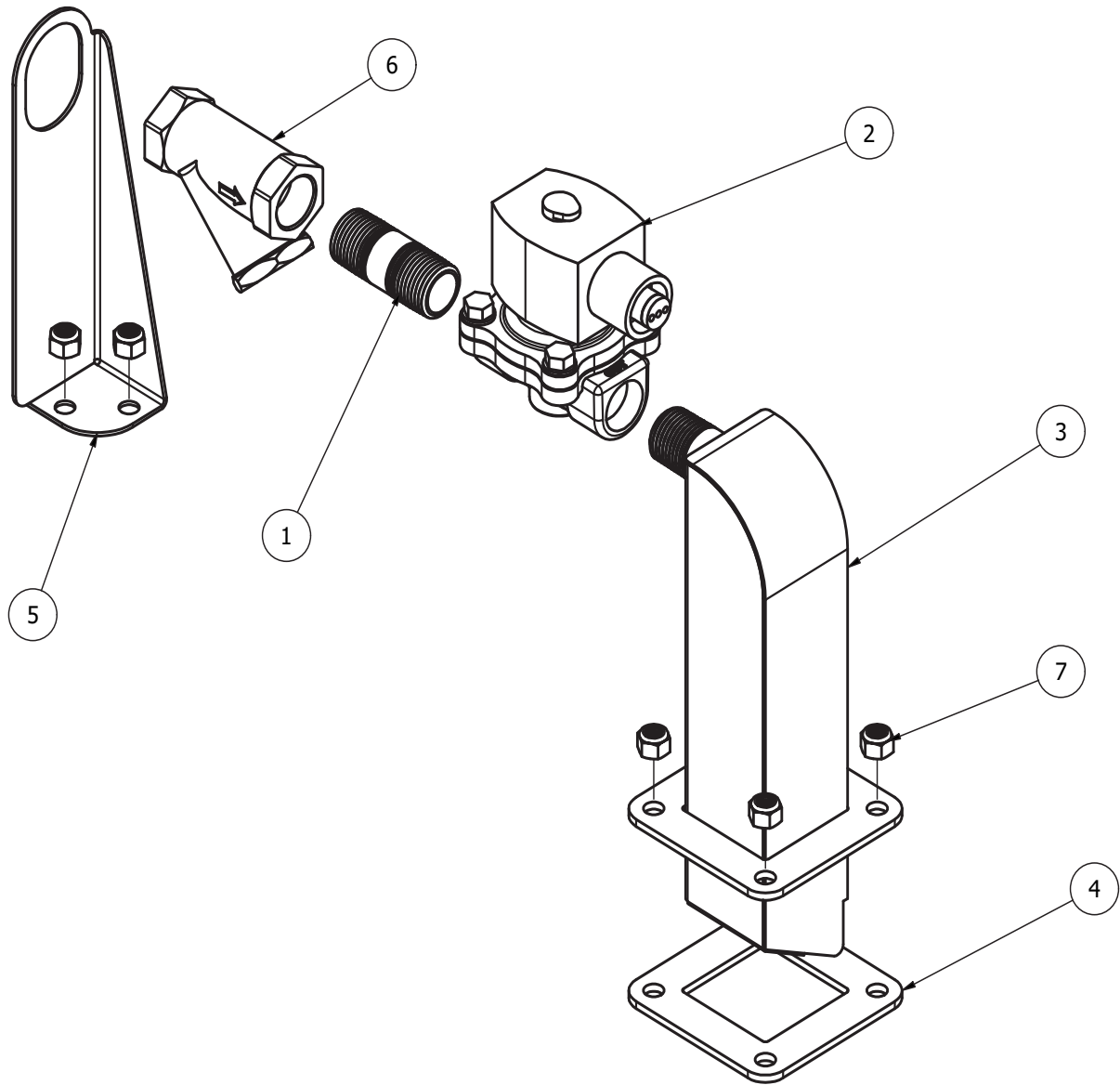
Fill and Air Gap Assembly

Item No.	Part No.	Description	Qty.
1	4825-00560	Brass Nipple 1/2" x 2"	1
2	4905-00562	110V x .50 Inlet Solenoid Valve	1
3	7100-00102	Air Gap Weldment	1
4	4000-00107	Air Gap Gasket	1
5	7000-00128	Plumbing Support Bracket	1
6	4825-00561	Conbraco "Y" 1/2" Strainer	1
7	5325-00392	1/4-20 S/S Coarse Locknut with Nylon	6

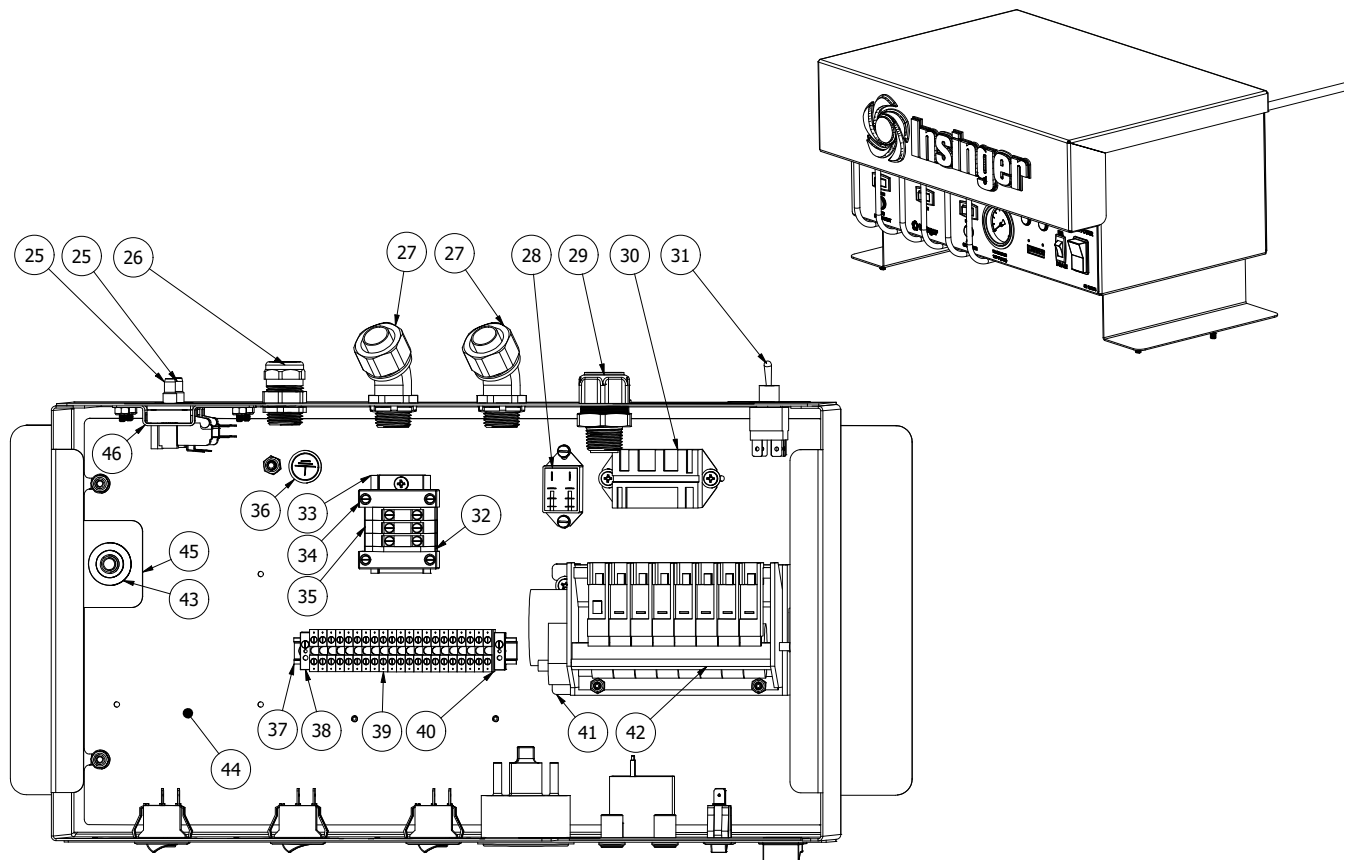
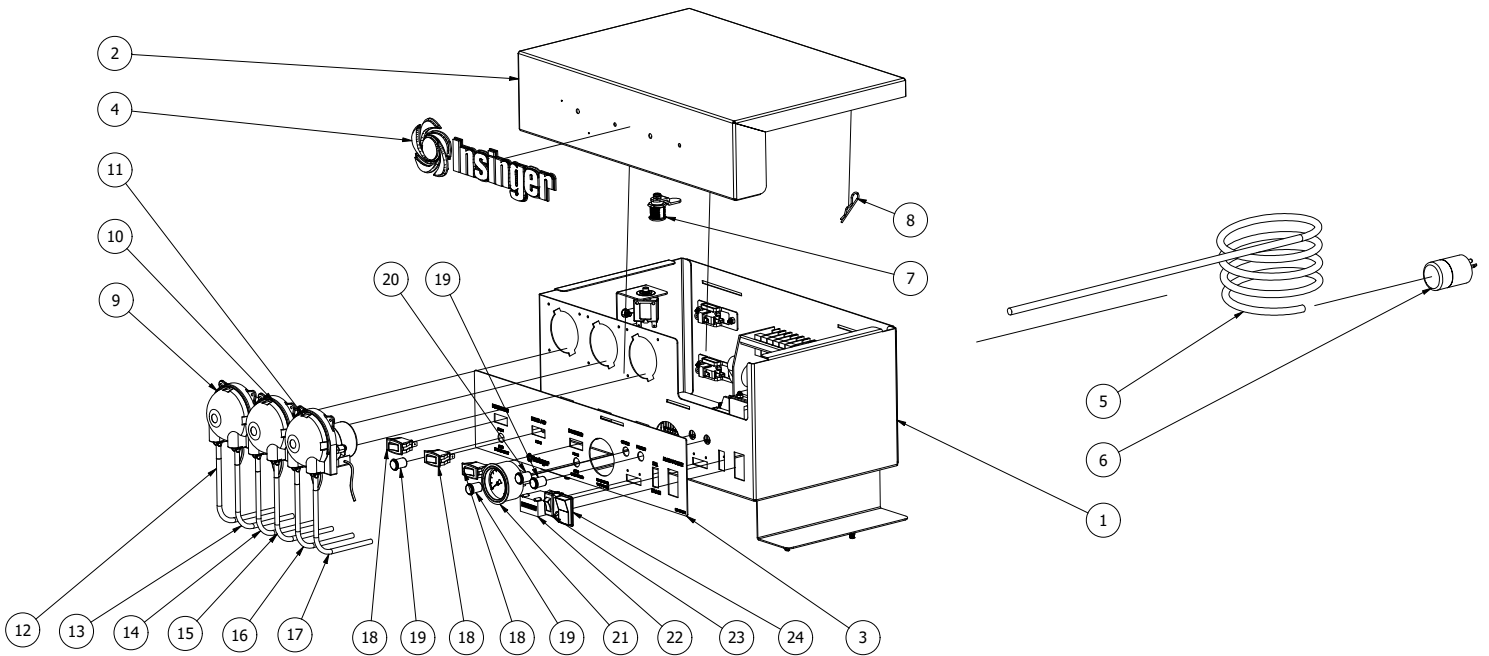
Control Box Assembly (115V)

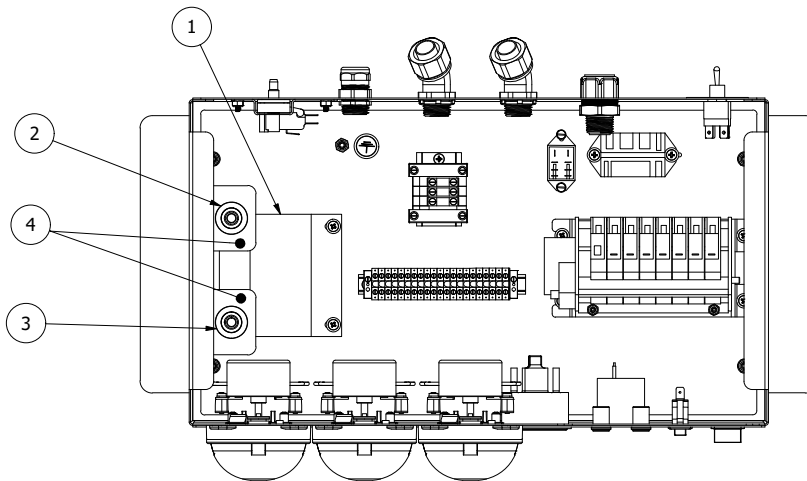
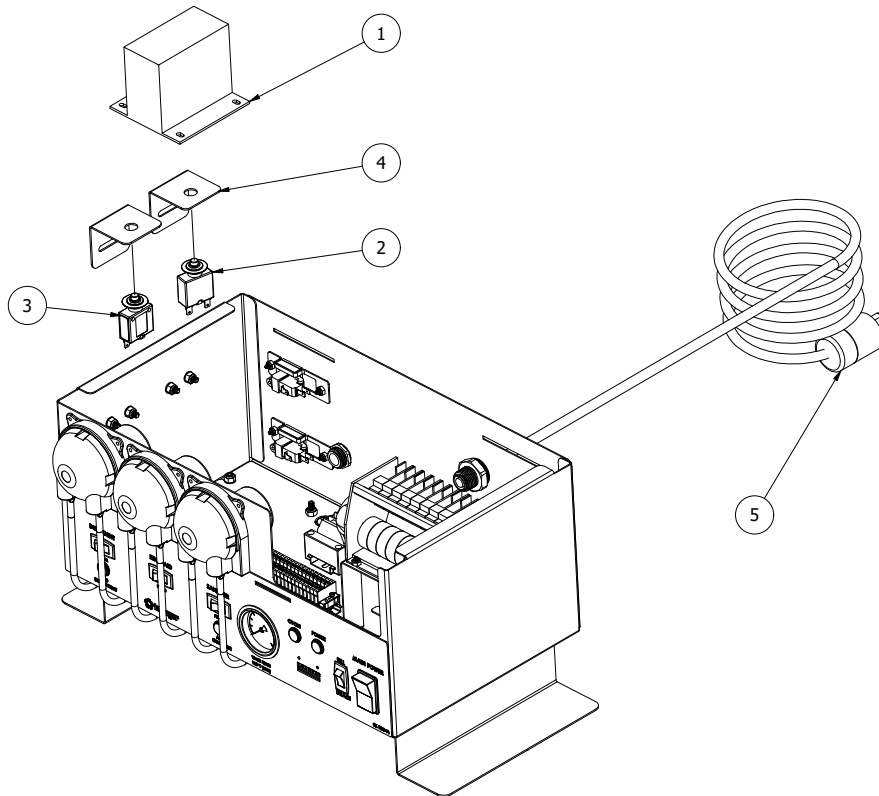

Control Box Assembly (115V)

Item No.	Part No.	Description	Qty.
1	7100-00596	Control Box Weldment	1
2	7000-00264	Control Box Lid	1
3	9600-00380	Control Box Overlay Sticker	1
4	9600-00513	Insinger Logo	1
5	7500-00722	Cable, 14/3 10ft Length	1
6	5915-00719	Electrical Plug, 120V 20A, NEMA 5-20P	1
7	6330-00512	Cam Lock (5/8")	1
8	5340-00440	Cotter Pin, 3/8" to 1/2" Diameter	1
9	6110-00693	Chemical Pump & Motor, 120V, Red	1
10	6110-00691	Chemical Pump & Motor, 120V, Blue	1
11	6110-00692	Chemical Pump & Motor, 120V, Clear	1
12	7500-00530	Tube, 1/4" OD x .17" ID Red, Pump In	1
13	7500-00532 / 7500-00710	Tube, 1/4" OD x .17" ID Red, Pump Out Standard/High	1
14	7500-00533 / 7500-00711	Tube, 1/4" OD x .17" ID Blue, Pump In Standard/High	1
15	7500-00534 / 7500-00712	Tube, 1/4" OD x .17" ID Blue, Pump Out Standard/High	1
16	7500-00535	Tube, 1/4" OD x .17" ID Clear, Pump In	1
17	7500-00537 / 7500-00714	Tube, 1/4" OD x .17" ID Clear, Pump Out Standard/High	1
18	5930-00429	Switch, Rocker SPST 125 to 250V Off/On	3
19	5995-00433	Light, 120V Red Flush Indicator	3
20	5995-00432	Light, 120V Green Flush Indicator	1
21	5015-00428	Thermometer Gauge w/ Logo 8ft	1
22	5999-00430	Counter, 6 Digit Rear Mounted	1
23	5930-00398	Switch, Rocker 10A 125VAC (On) Off (On)	1
24	5930-00431	Switch, Rocker Maintained DPST 20A 125V	1
25	5930-00448	Vacuum Switch	2
26	5915-00446	Connector, Liquid Tite 3/8" Straight	1
27	5915-00434	Connector, Liquid Tite 3/8" 45 Degree	2
28	5945-00569	Relay, DPDT 120VAC 10 A Top Mount	1
29	5915-00651	Cord Strain Relief, 1/2"	1
30	5945-00570	Relay, Power 100-120VAC Single Pole	1
31	5930-00436	Switch, Toggle DPDT	1
32	5940-00656	Terminal Block End Plate	1
33	7500-00653	DIN Rail, 35 mm x 2" Length, Alum	1
34	5940-00654	Terminal Block End Clamp	2
35	5940-00655	Terminal Block 600V 60A	3
36	9600-00469	Label, "Ground" UL Vinyl Self Stick	1
37	7500-00707	DIN Rail, 15mm perf. NS15 X 5-1/8" lg.	1
38	5940-00706	End Clamp, Phoenix E/MK	2
39	5940-00704	Terminal Block, Phoenix #MBK 2.5/E	21
40	5940-00705	End Cover, D-MBK 2.5/E	1
41	7000-00269	Bracket, Cam Timer	1
42	5960-00568	Timer, Cam 8 Contacts 120V 60 Hz (LT-40)	1
43	5925-00571	Breaker, Pressure Reset 20A Push Btn Reset	1
44	7000-00449	Control Box Mounting Plate	1
45	7000-00516	Bracket, Pressure Switch	1
46	7000-00515	Bracket, Vacuum Switch	2

Control Box Assembly (208/230V)

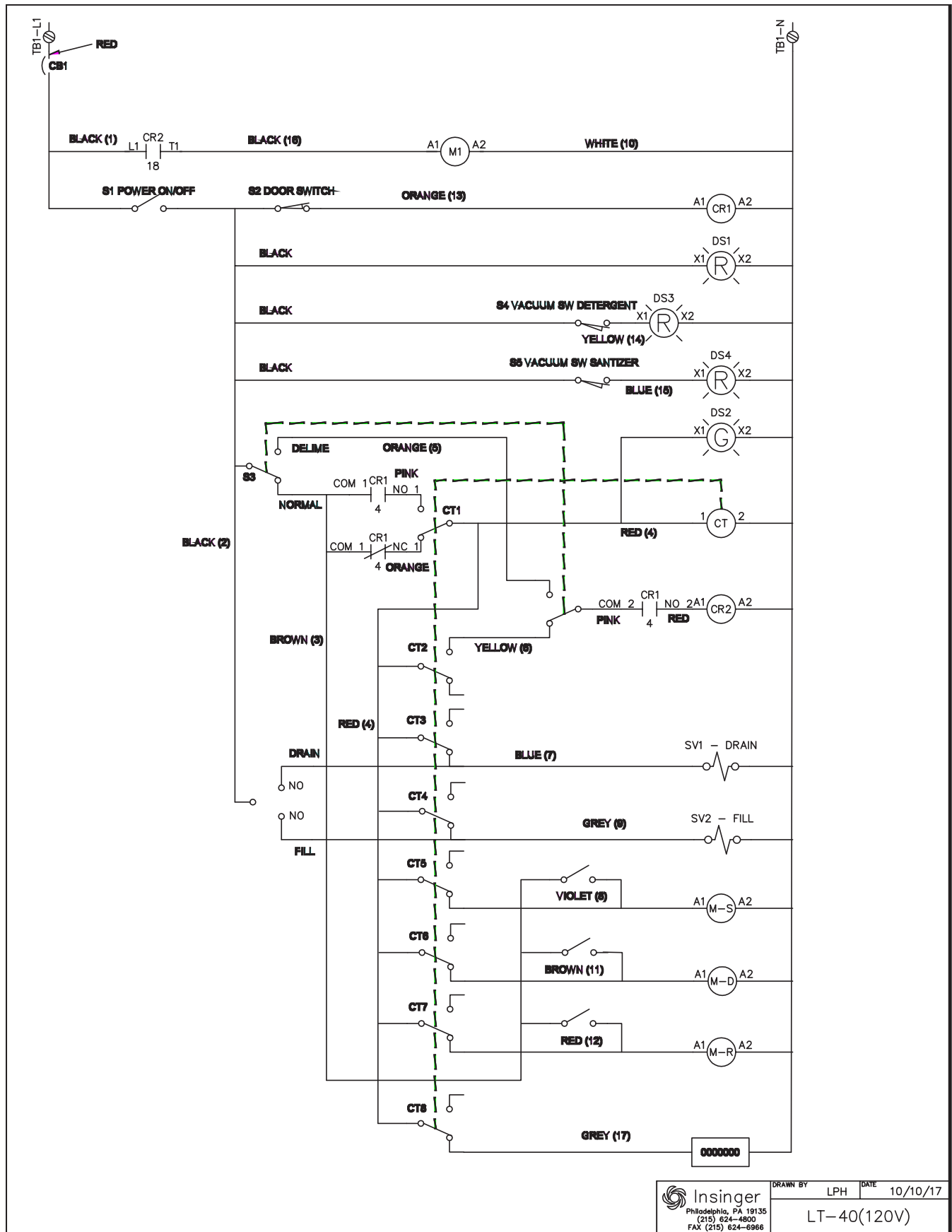
Item No.	Part No.	Description	Qty.
1	5950-00717	Transformer, 208/230/460V to 115V 150VA	1
2	5925-00715	Breaker, Pressure Reset 15A Push Btn Reset	1
3	5925-00716	Breaker, Circuit Breaker 2A Push Btn Reset	1
4	7000-00516	Bracket, Pressure Switch	2
5	5915-00720	Electrical Plug, 250V 15A, NEMA 6-15	1



 Philadelphia, PA 19135 (215) 624-4800 FAX (215) 624-6966	DRAWN BY	LPH	DATE	10/10/17
	LT-40(120V)			

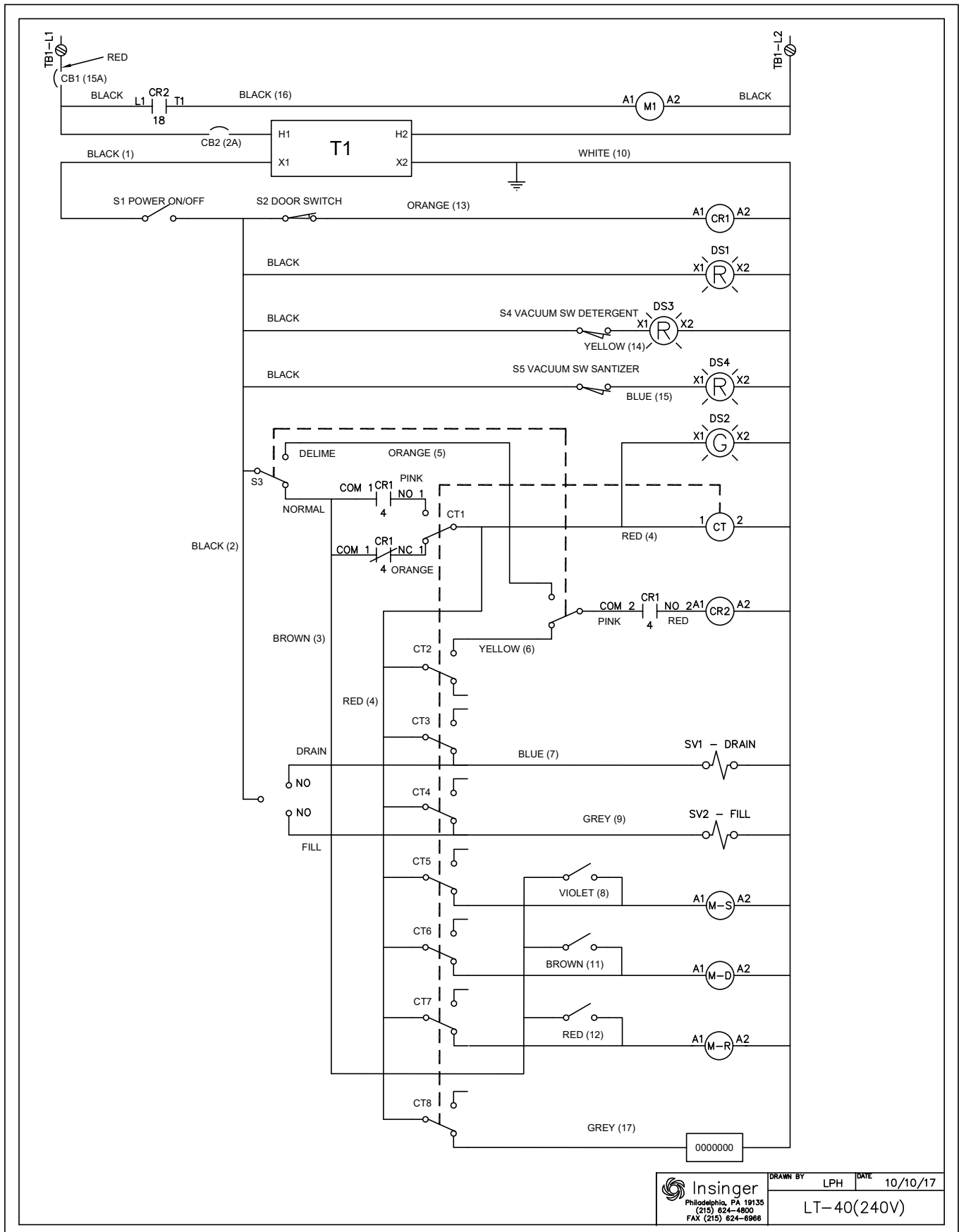

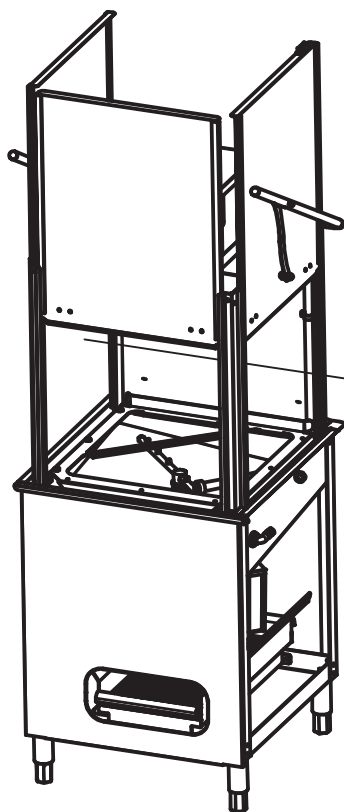

STEP 1: Fully extend doors open

STEP 2: Angle the false panel and insert it through the side door of the machine

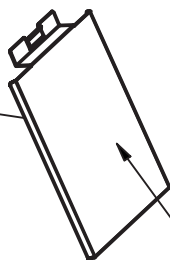

***NOTE:** Make sure the flat side of the panel will be facing the inside of the machine

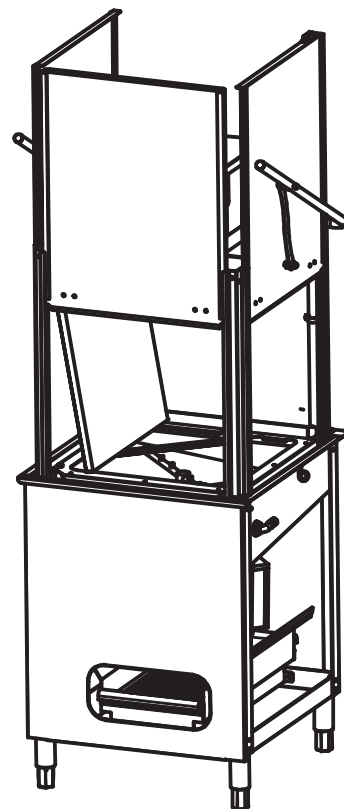

STEP 3: Hold the false panel at an angle and secure the upper bent flange of the panel to the side flange of the dishwasher hood. The bent flange should be facing inward. See picture below

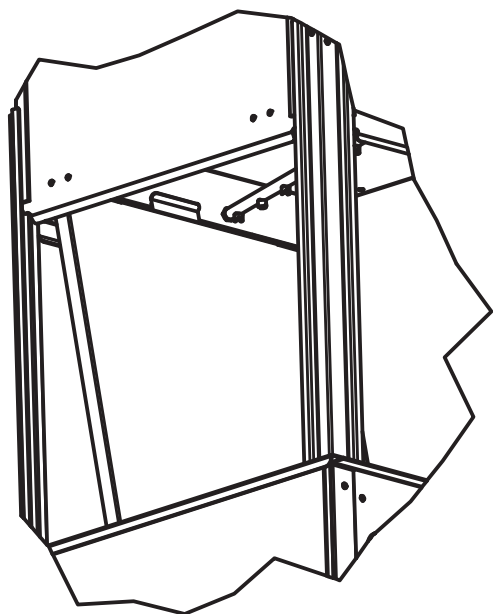

STEP 4: Align the panel perpendicular with the track so the holes on the bottom of the panel line up with the holes on the track

STEP 5: Fasten the panel down with the 3, 1/4-20 hexhead screws and locknuts that are provided with this kit

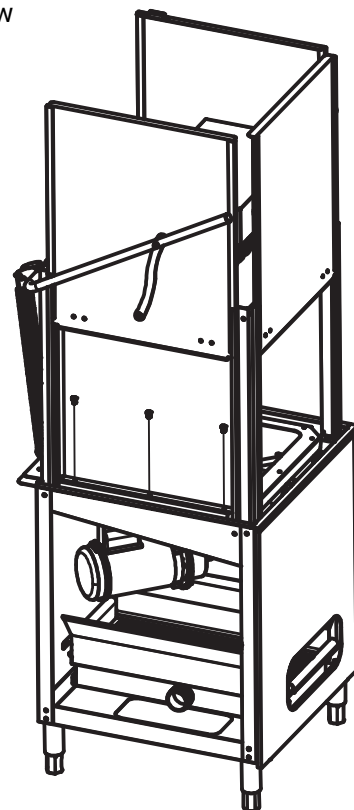

USE SAME PROCEDURE FOR INSTALLING FRONT FALSE PANEL



Insinger Machine Company
6245 State Road
Philadelphia, PA 19135-2996

800-344-4802

Fax 215-624-6966

www.insingermachine.com