



TECHNICAL MANUAL
Undercounter Dishwasher

RL-30

FOR UNITS AFTER DECEMBER 2016

Installation, Operation, and Maintenance Instructions

Insinger Machine Company
6245 State Road
Philadelphia, PA 19135-2996

800.344.4802
Fax 215.624.6966
www.insingermachine.com

Thank you for purchasing this quality Insinger product.

On the space provided below please record the model, serial number and start-up date of this unit:

Model: _____

Serial Number: _____

Start-Up Date: _____

When referring to this equipment please have this information available.

Each piece of equipment at Insinger is carefully tested before shipment for proper operation. If the need for service should arise please contact your local Authorized Insinger Service Company.

A Service Network Listing is provided on our web site, www.insingermachine.com or call Insinger at 800-344-4802 for your local authorized servicer.

For proper activation of the Insinger Limited Warranty a SureFire™ Start-Up & Check-Out Service should be completed on your machine. Refer to the Introduction section in this manual for an explanation of Insinger SureFire™ Start-Up & Check-Out Program.

Please read the Insinger Limited Warranty and all installation and operation instructions carefully before attempting to install or operate your new Insinger product.

To register your machine for warranty by phone, fax or the internet or for answers to question concerning installation, operation, or service contact our Technical Services Department:

TECHNICAL SERVICE CONTACTS	
Toll-Free	800-344-4802
Fax	215-624-6966
e-mail	service@insingermachine.com
Web site	www.insingermachine.com

TABLE OF CONTENTS

Part 1	2-7
Technical Information	
Catalog Specification Sheet	
Introduction	
Warranty	
Part 2	8
Installation Instructions	
Part 3	9-11
Operating Instructions	
Part 4	12
Cleaning /General Maintenance	
Part 5	13
Troubleshooting	
Part 6	14-38
Electrical Schematics & Replacement Parts	

RL-30
Automatic Undercounter Dishwasher

- Automatic, hot water sanitizing undercounter dishwasher with timed wash
- Capacity is 30 racks per hour or 750 dishes per hour.
- .79 gallons per rack final rinse consumption.
- Energy efficient.
- Only requires a 30 amp circuit.
- TempGuard™ final rinse temperature control ensures sanitized.

Project _____ CSI11400 _____
 Item _____ Approval _____
 Quantity _____ Date _____



Superior cleaning action with 7 bayonets style wash arms with 42 fixed wash jets.

STANDAR FEATURES

- . 7 bayonet style wash arms with 42 fixed wash jets.
- . 6 upper rinse jets.
- . 8 lower revolving rinse jets.
- . Fully automatic operation.
- . Independent wash and rinse systems.
- . Automatic tank fill.
- . Countinuous wash cycle.
- . Electric immersion tank heat: 1.8 kW.
- . Low water protection for heater.
- . TempGuard™ final rinse temperature control.
- . Thermostatic controls for the wash tank and final rinse heaters.
- . Built-in electric booster: 3.5 kW (70 rise).
- . Only requires a 30 amp circuit.
- . Motor overload protection
- . Double wall construction for noise reduction and thermal insulacion.
- . Deep drawn side walls, wash tank, door and rack guides for easy cleaning.
- . Door interlock safety switch.
- . Flexible water connection.
- . Single point electrical connection for motor, controls, heater and booster.
- . Built-in detergent and rinse-aid pumps.
- . Pumped drain.
- . Food soil strainer system.
- . Pressure reduction valve and line strainer.
- . 2 plastic 20" x 20" racks (1 plate, 1 silver).

OPTIONS

- . Additional plastic 20"x 20" rack.
- . Drain quench system.
- . 6" stand.
- . 17" stand.





RL-30

Automatic Undercounter Diswasher

LTR	DESCRIPTION	SIZE
A	HOT WATER SUPPLY - 110° F MIN / 140° F MAX	¾" FPT x 3.5 FT LG. FLEX HOSE
B	ELEC: 1.0 HP + 4.7 KW. 18 FLA ON 208/1/60 1.0 HP + 5.2 KW. 20 FLA ON 220-240/1/60	10-3C x 8 FT LG SJ CABLE WITH NEMA L6-30P
C	DRAIN CONNECTION (SEE NOTE2). MAX HEIGHT	¾" x 4 FT LG. FLEX HOSE

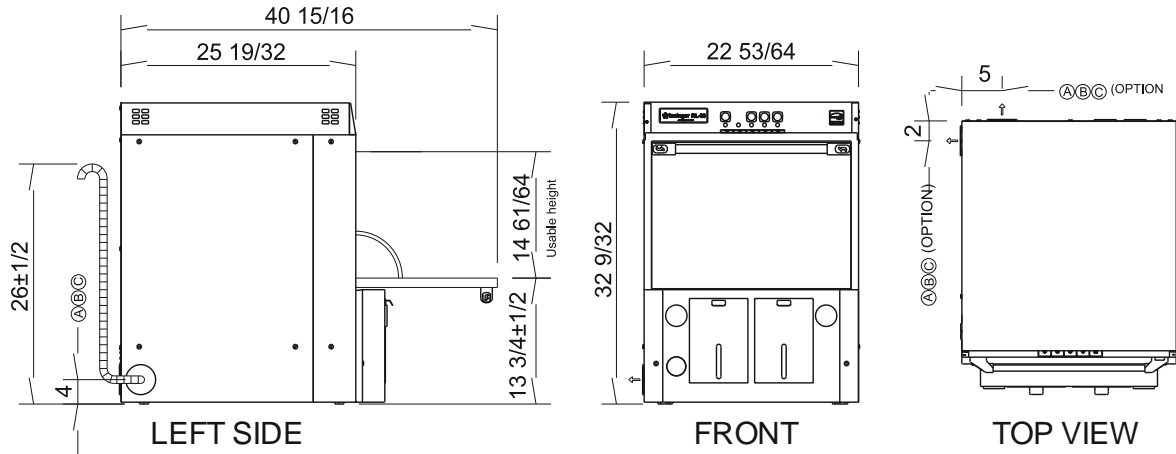

NOTE: For all rough in connections see installation and layout detail drawing

Capacity Per Hour	30 racks. 750 dishes. 68 meals.	<h2 style="text-align: center;">SPECIFICATIONS</h2> <p>CONSTRUCTION- Machine wash tank, casing and rinse pipers are made 304 stainless steel. The polypropylene wash manifold, arms and jets are heat, alkali and rust resistance.</p> <p>CONTROLS- Front mounted controls are easy to read with indicator lights for power heat and drain. Control components mounted in splash-proof box. Box is on slides for easy service.</p> <p>WAS/RINSE SYSTEM- 42 fixed high volume spray nozzles, 14 full coverage rinse nozzles.</p> <p>DRAIN SYSTEM- Separate drain pump lifts up to 24 inches above floor level.</p> <p>INTERNAL HEIGHT- 11 ½ inches.</p>
Tank Capacity	7.4 gallons.	
Motor size	1 hp (wash).	
Electric Usage	2.8 kW wash tank. 3.5 kW built-in booster (40°-70° rise).	
Water Inlet Temperature	110° F to 140° F.	
Final Rinse Peak Flow at 20 psi min.	4.75 gallons/minute.	
Final Rinse Consumption at 20 psi min.	23.8 gallons/hour. 0.79 gallons/rack.	
Exhaust Hood Requirement	None.	
Time Cycle	120 Seconds.	
Peak Rate Drain Flow	9 gallons/minute.	
Shipping Weight	165 lbs.	
Current Draw Amps 208-240 / 1 / 60	Electric with Built-in Booster 18-20	



NOTE: Due to product improvement we reserve the right to change information and specification without notice.

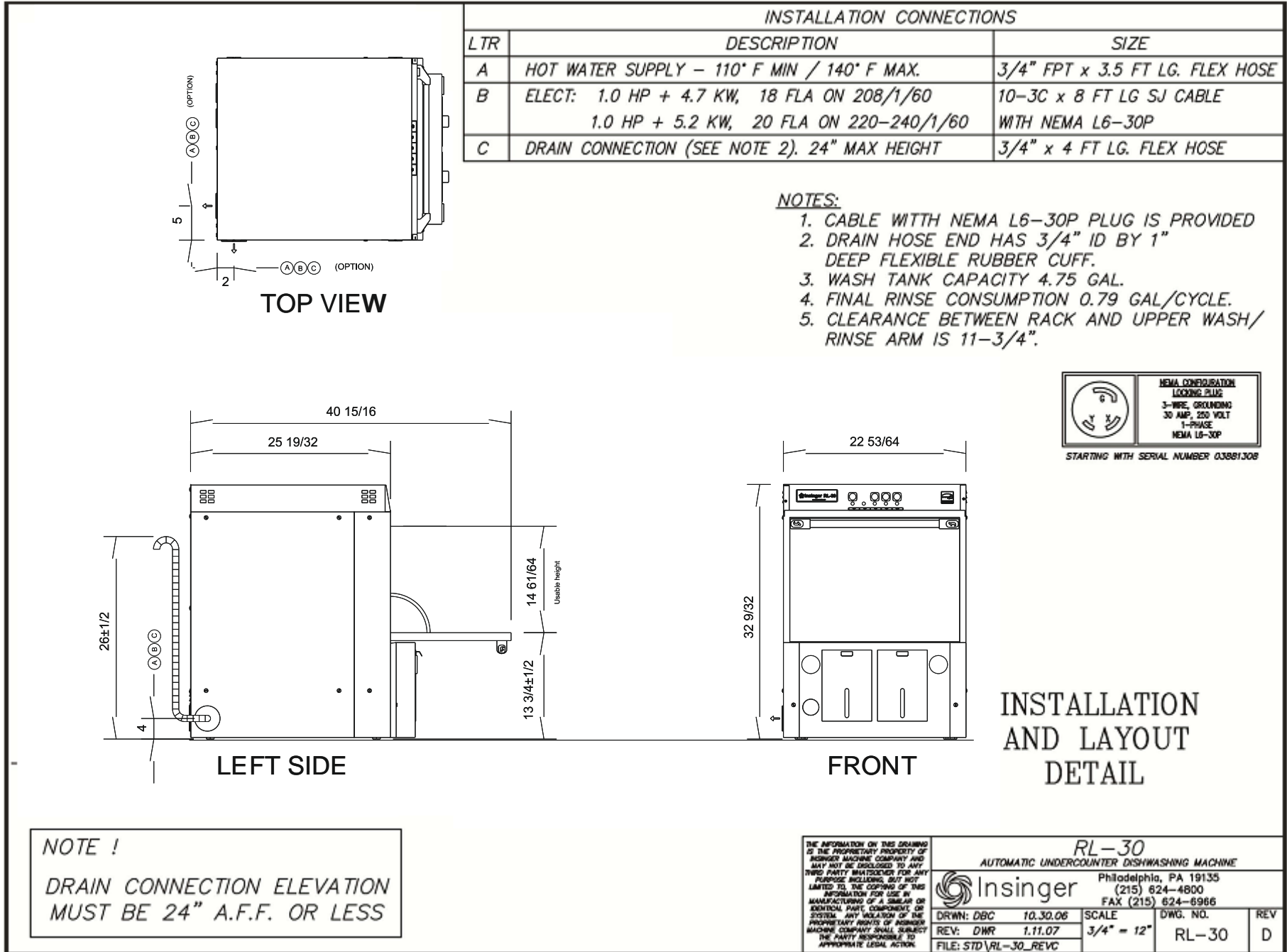

NOTE !

DRAIN CONNECTION ELEVATION
MUST BE 24" A.F.F. OR LESS

THE INFORMATION ON THIS DRAWING IS THE PROPRIETARY PROPERTY OF INSINGER MACHINE COMPANY AND MAY NOT BE DISCLOSED TO ANY THIRD PARTY WHATSOEVER FOR ANY PURPOSE INCLUDING, BUT NOT LIMITED TO, THE COPYING OF THIS INFORMATION FOR USE IN MANUFACTURING OF A SIMILAR OR IDENTICAL PART, COMPONENT OR SYSTEM. ANY VIOLATION OF THE PROPRIETARY RIGHTS OF INSINGER MACHINE COMPANY SHALL SUBJECT THE PARTY RESPONSIBLE TO APPROPRIATE LEGAL ACTION.				
RL-30 AUTOMATIC UNDERCOUNTER DISHWASHING MACHINE				
		Philadelphia, PA 19135 (215) 624-4800 FAX (215) 624-6966		
DRWN: DBC	10.30.06	SCALE	DWG. NO.	REV
REV: DWR	1.11.07	3/4" = 12"	RL-30	D
FILE: STD\RL-30_REV.C				

RL-30 UNDERCOUNTER DISHWASHER

INTRODUCTION

Purpose

The purpose of this technical manual is to provide installation, operation, cleaning and maintenance directions.

A section is provided for replacement parts.

Scope

This manual contains all pertinent information to assist in the proper installation, operation, cleaning, maintenance, and parts ordering for the Insinger RL-30 Undercounter dishwasher. The installation instructions are intended for qualified equipment installers. The operation and cleaning instructions are intended for the daily users of the equipment. The maintenance and parts sections are intended for qualified service and/or maintenance technicians. Replacement parts may be ordered directly from our factory or from your local Insinger Authorized Service Agency. **You can speak to the Insinger Technical Services Department, 800-344-4802, or e-mail us at service@insingermachine.com.** When calling for warranty information or replacement parts please provide the model and serial number of your Insinger Equipment. These important numbers should be noted in this manual on the spaces provided on the opening page.

Surefire™ Start-up & Check-out Program

Insinger is proud to offer our exclusive Surefire™ Start-up & Check-out Program to our commercial customers. This service is included in the purchase price of your new Insinger dishwasher. We will provide an authorized factory service technician for the initial start-up of your new Insinger dishwasher to ensure it is running at optimum levels from the very first pass. Please call the factory or your local Insinger Sales Representative to schedule this service.

This machine must be operated with detergent in the integral detergent dispensing system to insure proper washing.

Intended use

The Insinger dishwasher RL-30 may only be used for cleaning plates, cups, dishes, cutlery and similar restaurant ware and commercial catering.

Any change in design or use of the dishwasher carried out without the written permission of Insinger, will lead to warranty nullification.

If damage is caused to the dishwasher due to failure to observe the instructions given in this manual, no claims under the warranty agreement can be submitted to Insinger Machine Company.

Safety Instructions

Make sure that you have read and understood the operating instructions before you start to use the dishwasher. The Insinger customer service department can tell you how to operate the washer and how it works.

Definitions

Throughout this guide you will find the following terms: **WARNING, CAUTION, & NOTE.**

WARNING indicates potential physical danger.

CAUTION indicates potential equipment damage.

NOTE indicates helpful operating hints or tips.

You will visually be able to identify each as shown below:



WARNING:

Indicates potential physical danger.

CAUTION:

Indicate potential equipment damage.



NOTE:

Indicates helpful operating hints or tips.

INSINGER MACHINE COMPANY LIMITED WARRANTY

Insinger Machine Company, Inc. (Insinger) hereby warrants to the original retail purchaser of this Insinger Machine Company, Inc. product, that if it is assembled and operated in accordance with the printed instructions accompanying it, then for a period of either 15 months from the date of shipment from Insinger or 1 year (12 months) from the date of installation or start-up that said Insinger product shall be free from defects in material and workmanship. Whichever one of the two aforesaid limited warranty time periods is the shortest shall be the applicable limited warranty coverage time period.

Insinger may require reasonable proof of your date of purchase; therefore, you should retain your copy of invoice or shipping document.

This limited warranty shall be limited to the repair or replacement of parts which prove defective under normal use and service and which on examination shall indicate, to Insinger's satisfaction, they are defective. Any part that is claimed to be defective and covered by this limited warranty must be returned to Insinger. An RMA# must be obtained from the Insinger Warranty Department before returning any material. Return may be done through an Authorized Service Agency. Furnish serial number of machine and RMA# with shipment and send to:

Insinger Machine Company
6245 State Road
Philadelphia, PA 19135-2996

If Insinger's inspection confirms the defect and the claim, Insinger will repair or replace such part without charge and return it to you freight or postage prepaid.

This limited warranty does not cover any failure or accident, abuse, misuse, alteration, misapplication, improper installation, fire, flood, acts of God or improper maintenance or service,

or failure to perform normal and routine maintenance as set out in the instruction booklet (operating instructions) or for improper operation or failure to follow normal operating instructions (as set out in the instruction booklet). Insinger is not responsible nor liable for any conditions of erosion or corrosion caused by corrosive detergents, acids, lye or other chemicals used in the washing and or cleaning process.

Service must be done by either Insinger Appointed Service Agencies or agencies receiving prior authorization from Insinger.

All warranty work must be done during normal working hours, unless purchaser receives prior authorization from Insinger.

There are no other express warrants except as set forth herein and any applicable implied warranties of merchantability and fitness are limited in duration to the period of coverage of this express written limited warranty. This limited warranty supersedes all other express warranties, implied warranties of merchantability and fitness or limited warranties as of this date, January 1, 1998. Some states do not allow limitation on how long an implied warranty lasts so this limitation may not apply to you.

Insinger is not liable for any special, indirect or consequential damages. Some states do not allow the exclusion or limitation of incidental or consequential damages, so this limitation nor exclusion may not apply to you.

Insinger does not authorize any person or company to assume for it any other obligation or liability in connection with the sale, installation, use, removal, return or replacement of its equipment: and no such representations are binding on Insinger.

INSINGER MACHINE COMPANY LIMITED WARRANTY – COMERCIAL MARINE USE

Insinger Machine Company, Inc. (Insinger) hereby warrants to the original retail purchaser of this Insinger Machine Company, Inc. product, that if it is assembled and operated in accordance with the printed instructions accompanying it (installation manual), then for a period of 15 months from the date of installation on board the vessel, that said Insinger product shall be free from defects in material and workmanship.

Insinger may require reasonable proof of your date of equipment install, therefore, you should retain your copy of invoice or shipping document.

This limited warranty shall be limited to the replacement of parts which prove defective under normal use and service and which on examination shall indicate, to Insinger's satisfaction, they are defective. Any part that is claimed to be defective and covered by this limited warranty must be returned to Insinger. Furnish serial number of machine with shipment and send to:

Insinger Machine Company, Inc.
6245 State Road
Philadelphia, PA 19135-2996

If Insinger's inspection confirms the defect and the claim, Insinger will repair or replace such part without charge and return it to you freight or postage prepaid. If part damages are not covered, Insinger will contact the customer and advise.

If a factory trained authorized technician is required to repair or replace defective parts or material during the 18 month warranty period, the cruise line will be responsible for the payment of travel expense and a minimum of four hours labor.

Labor will be billed to the customer at a reduced rate of \$40.00 per hour. If sailing with a vessel is required, then an eight hour per day minimum will apply.

This limited warranty does not cover accident, abuse, misuse, alteration, misapplication, improper installation, fire, flood, or improper maintenance or service, or failure to perform normal and routine maintenance as set out in the instruction booklet (operating instructions) or for improper operation or failure to follow normal operating instructions (as set out in the instruction booklet).

Insinger is not responsible nor liable for any conditions of erosion or corrosion caused by corrosive detergents, acids, lye or other chemicals used in the washing, caring and or cleaning process.

Warranty service must be done by either Insinger Appointed Service Agencies or agencies, customers galley engineers receiving prior authorization from Insinger.

There are no other express warrants except as set forth herein and any applicable implied warranties of merchantability and fitness are limited in duration to the period of coverage of this express written limited warranty. This limited warranty supersedes all other express warranties, implied warranties of merchantability and fitness or limited warranties as the above date.

Insinger does not authorize any person or company locally or overseas to assume for it any other obligation or liability in connection with the sale, installation, use, removal, return or replacement of its equipment; and no such representations are binding on Insinger.

INSTALLATION AND CONNECTION**WARNING:**

Water and waste piping and connections shall comply with the International Plumbing Code, International Code Council (ICC) or the Uniform Plumbing Code, International Association of Plumbing and Mechanical Officials (IAPMO).

Check for Completeness:

After unpacking the machine, first check the delivery against the packing slip to ensure that it is complete, and inspect for damage that may have occurred during transportation. Immediately report any damage to the carrier, the insurance company and the manufacturer.

Setting Up and Alignment:

When setting up the machine, remember that the machine gives off steam during operation (when you open the door). Protect adjacent wooden furniture to prevent it absorbing moisture and swelling.

CAUTION:

Protect the washer against frost. Systems that carry water can be damaged if they freeze.

The machine must be completely level when installed. Adjust the machine's feet to compensate for any unevenness of the floor.

CAUTION:

Note all the information on the enclosed connection diagram. For the machine to work correctly, the required water pressure and flow rate must be guaranteed at all time.

Connection to the Water Supply:

- Use a ball valve and a pressure reducing valve for the water supply and drain near the washer and in an easily accessible position. It should not be located behind the washer.
- PRV should be set to supply 20 psi flow pressure.
- The washer is equipped with a drain pump. The maximum drain pump lift above floor is 24".

Connection to the Water Supply (continued):

- Connection should provide for a minimum of 24" (600mm) of flexible line at machine so that unit can be moved for cleaning. Note: Unit is provided with 37" (940mm) flexible connections.

Connection to the Drain:

Unit must be connected to drain capable of handling 4.75 gal/min flow and must be provided with a proper air gap at connection. Failure to provide air gap will result in improper or inconsistent draining of unit and potential overflow condition. The maximum height of the drain connection is 24".

Connection to the Power Supply:

Before using the washer, check that all electrical protection systems are working correctly.

Attention: The machine should not be regarded as isolated from the power supply unless switched off at the customer's main switch.

- The total amp load is 20 fla.
- The electrical connection of the washer is to be fused by the customer with time-lag fuses or circuit breaker according to wattage (see the machine rating plate). No other appliances may be fused with the washer.
- Install according to local regulations, this unit requires a 30 amp circuit breaker in the electric supply.
- Connect the power cord to the customers power system, make sure the unit is properly grounded. Unit comes equipped with a NEMA L6-30P plug.
- The power cord comes attached from the factory, if replacement is needed it must be done by certified personnel only.

Final Tasks:

The washer must be connected to all services (electricity supply and to the fresh water and waste water systems), prior to testing the machine & installation. Make sure incoming water line is flushed of debris before connecting to unit.

OPERATING INSTRUCTIONS

Turn on the main power, S1. The machine will fill. the booster tank fills and continues until the wash tank of the machine is full.* Once the wash tank is full the booster tank heater (R1) is turned "on". Once the booster has reached operating temperature 185°F (85°C) (set by B1) the wash tank heater (R2) is activated until optimal wash temperature 158°F (70°C) (set by B2) is reached.

At any point during the heating cycle of the booster and/or the wash tank, a cycle may be started by pressing the cycle switch (S4). If final rinse temperature has been achieved the unit will run a normal 2 minute cycle and stop. If final rinse temperature has not been achieved the unit will stay in wash mode until the final rinse reaches preset temperature (TempGuard™ feature). TempGuard™ is adjustable by B7, TempGuard™ thermostat.



* The water level in the wash tank should be within a 1/2" from the top of the overflow drain pipe.

Initial Start-Up	
Power switch on (Green button)	S1
Power light illuminates	H1
Rinse solenoid opens	Y1 (Only if door is closed)
Rinse booster fills	
Wash tank fills until pressure switch is closed	B3
Rinse tank heater turned "ON"	R1
Rinse temperature reached	B1
TempGuard™ light turns "ON"	H5
Wash tank heater is turned "ON"	R2
Wash temperature reached	B2

CAUTION:
Do not place anything on the open door.

NOTE:

 The booster heat and wash heat thermostat are located behind the front kick panel.

 Booster B1
 Wash B2
 Turn clockwise to increase set temperature.
 TempGuard™ B7

Continuing Operation	
Depress "Cycle Start" switch	S3
Cycle light illuminates	H2
Cam timer starts	D1
Rinse shot (~2 sec)	D1 cam 3 (initiates solenoid Y1)
Wash cycle (~101 sec)	D1 cam 2 (initiates solenoid KM3)
Dwell (~3 sec)	
Rinse Cycle (~11 sec)	D1 cam 3 (initiates solenoid Y1)
Drain cycle (0-1 min)	D1 cam 3 (initiates solenoid KA5)
Dwell (~3 sec)	
Cam timer stops	

WARNING:

 Do not open the door while the program is running. There is a risk of hot water spraying out of the machine.

 (The unit is equipped with a door safety switch, located behind the door.)

OPERATING INSTRUCTIONS
Draining:

Draining	
Pre-set timer KA5 Drain Timer preset to 30 seconds	
Draining the tank	
Turn machine off	S1
Open door	
Remove overflow standpipe	
Press drain button Note: If the tank does not drain completely, press again.	S2

NOTE:

Rinse heater (R1) and wash heater (R2) are never on at the same time. To override the "TempGuard™" feature activate relay KA2 by rotating the orange lever. Located on relay.

Adding Rinse Aid and Detergent:
CAUTION:

Only use detergent and rinse aid which are suitable for commercial washers, a non-foaming industrial alkaline detergent.

Do not use any soap intended for a residential dishwasher. This leads to large amounts of foam building up in the washer and will void your manufacturer's warranty.

CAUTION:

Detergents for commercial dishwashers cause corrosion. Always follow the instructions on the packaging and drums.

CAUTION:

Do not mix different detergent products, this could cause the dosing pump to break down due to crystallization

OPERATING INSTRUCTIONS
Chemical Connections:

The RL-30 is supplied with integral detergent and rinse additive pumps and the chemical hoses are located on the side of the dishmachine.

Detergent concentration should be between .25% (.30oz/gal) and .30% (.38oz/gal). Note: Always consult chemical manufacturer for proper concentration.

Preparing for operation:

- Locate the clear chemical pick up tubes on the side of the unit
- Identify the detergent pick up tube (smaller diameter ID tube) and place it in the container of commercial liquid detergent.
- Place the rinse additive pick up tube (larger diameter ID tube) in the container of commercial liquid rinse additive.

Priming the system:

- The detergent pump is self priming and runs during the rinse/fill cycle. The amount of detergent dispensed is controlled by the speed of the peristaltic pump. This can be adjusted by turning the control screw.

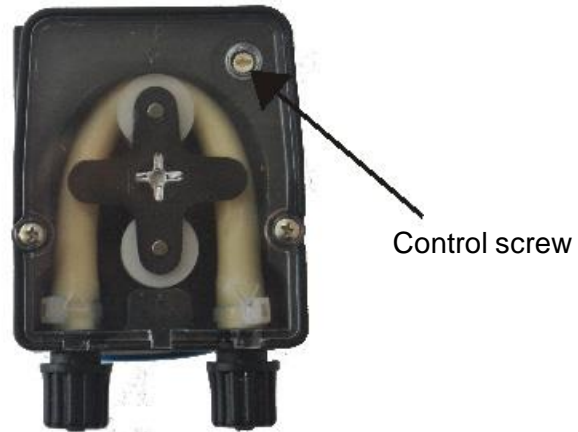

- The rinse additive pump is located behind the front kick panel. The pump is a diaphragm type pump and can be primed by inserting a screwdriver into the screw on the front/top of the pump, turning counter clockwise and then depressing the screw to begin the manual priming. Make several compressions until you see the rinse additive solution entering the check valve on the other side of the pump. The amount of rinse additive that is added to the system can be adjusted by turning the screw clockwise to decrease and counterclockwise to increase. Once set, the solution is then added automatically to the rinse system.

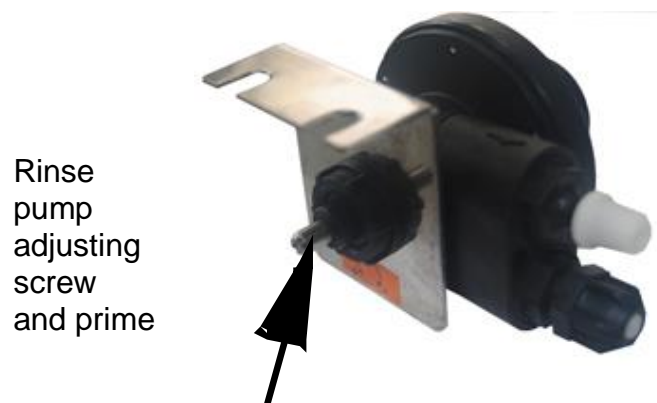

Rinse pump

CLEANING / GENERAL MAINTENANCE
Daily Cleaning:

At the end of each day drain the machine

- Turn machine off S1
- Open door
- Remove overflow stand pipe
- Press drain button S2 (drain pump runs for pre-set time). If tank does not drain completely press S2 again.
- Remove upper and lower plastic wash arms and flush clean with fresh water.
- Remove cylindrical scrap filter & rinse with fresh water until any debris is removed.
- With a clean dry cloth wipe out the inside chamber of the dishmachine.
- Reinsert the O flow, scrap filter and wash pipes.
- Clean the outside of the machine with a high grade stainless steel cleaner.
- Open door slightly to vent. This will allow the interior to dry.

If unit is not sealed to the floor, pull unit from installed position to clean floor under unit. Use suitable chemicals and frequency as conditions require.

The outside surfaces of the unit should be cleaned using a soft cloth and a cleaner designed for use on stainless steel. Note: using cleaners that contain chlorine will harm the surface of stainless steel.

	<p>WARNING:</p> <p>Do not spray outside of dishwasher with a hose or high pressure steam cleaner</p>
---	---

De-liming:

Machines that are operated in hard water areas and are not connected to an external water treatment system must be de-limed from time to time. There are de-liming agents specially designed for commercial dishwashers available for this purpose, please consult your detergent supplier.

	<p>WARNING:</p> <p>The RL-30 must be kept free of lime for proper operation. Lime will interfere with normal function.</p>
---	---

Initial Start-Up	
Add de-liming solution into the wash water	
Depress "De-lime" cycle button	S4
De-lime light illuminates	H6
Wash pump starts	M1
Continues "De-lime" cycle until button is turned "OFF"	S4

CAUTION:
<p>De-liming agents for commercial dishwashers cause corrosion. Always follow the instructions for use and safety instructions on the packaging and drums.</p>

Faults where it is not necessary to call Insinger.

You can rectify minor faults yourself following the steps described in the table below. If you are unable to rectify the fault, contact Insinger service (1-800-344-4802.)

Do not open any panels or expose any parts of the machine if tools are necessary to do so. Risk of electric shock.

Work on the electrical equipment should only be performed by service personnel. First disconnect the washer from the main power switch. Do not switch the washer on again until the cause of the fault has been identified.

WARNING:

Turn off the main switch on the dishwasher so it is isolated from the power supply.

Problem	A	B	C	D
Machine continues to fill	There is no soil blocking the pressure switch opening in tub	Connections to pressure switch are air tight and secure	The pressure switch is operating	Verify solenoid valve is operating properly
Machine fails to fill	Water supply to unit is on	Solenoid valve is operating properly		
Wash temperature incorrect	Verify door is closed	Verify door switch is functioning properly	Adjust thermostat B2	Verify thermostat is working
Rinse temperature incorrect	Adjust thermostat B1	Verify thermostat is working	Verify contactor is functioning properly	Verify heater is working properly
Machine continues to wash	Verify that the "de-lime" switch is not depressed	Verify that the rinse temperature has reached its set limit	Check B7 set point	Verify cam timer is working properly
Machine will not drain	Verify proper settings on drain delay timer (KA5)	Verify drain pump is functioning properly	Remove overflow tube	
Machine will not start	Hold start switch for 1 second	Verify S1 of cam timer is closed	Verify S2 of cam timer is closed	Verify contactor KM3 is energized

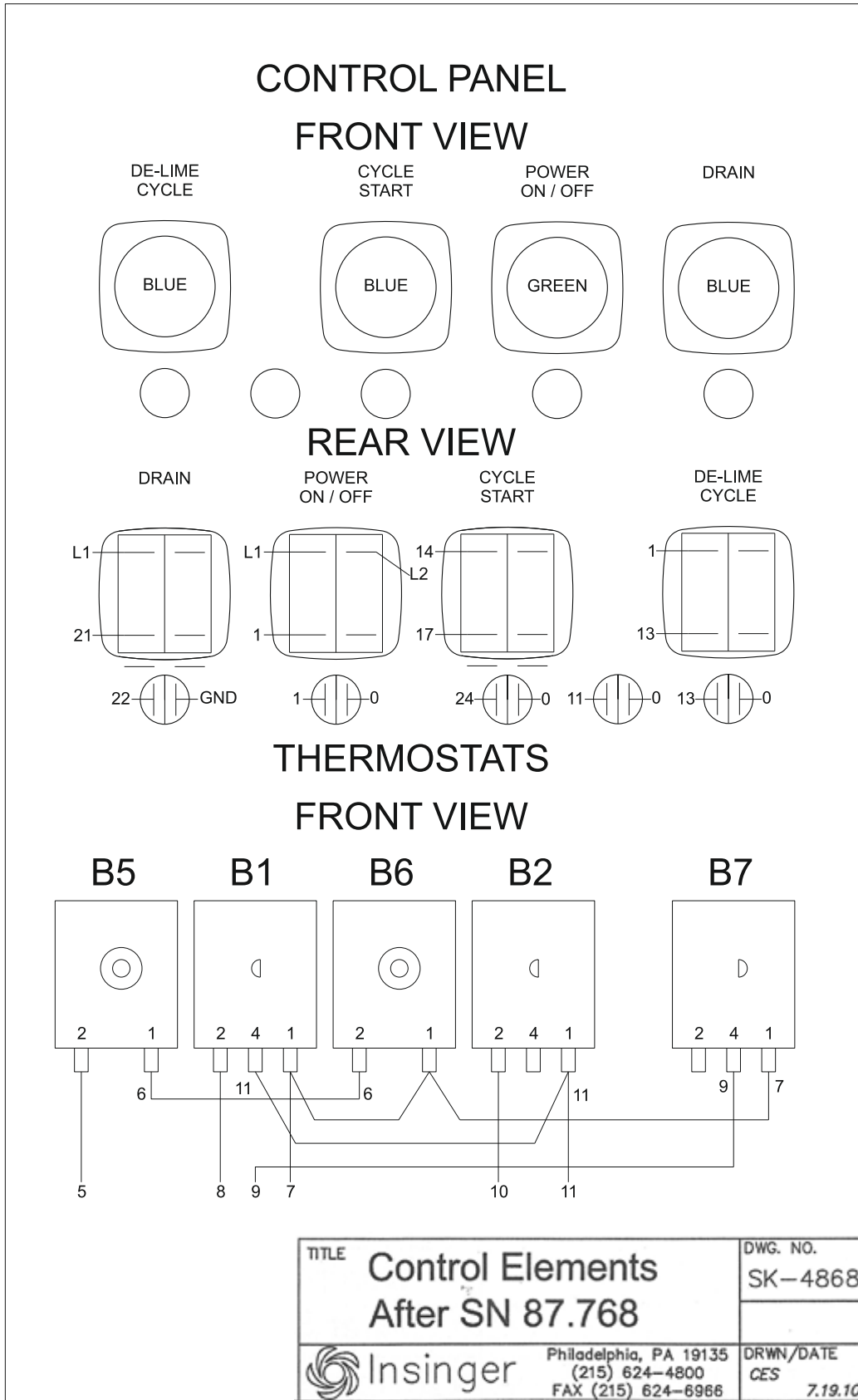

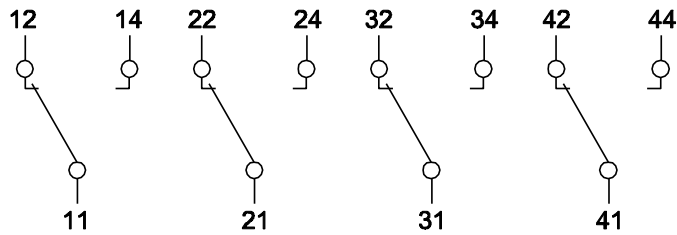
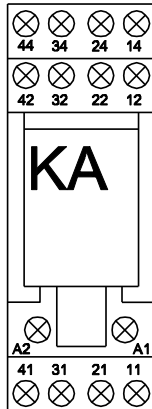

KA1,KA2 RELAY 4 NANC 6 A 250 V.
KA3,KA4 RELAY 2 NANC 12 A 250 V.

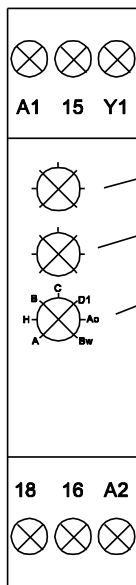

KA5 DRAIN PUMP TIMER.

.1 to 1 MIN (REGULATE APPROX. 30 SECONDS)

POSITION 1

C POSITION

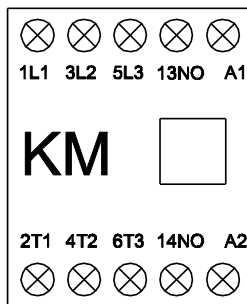
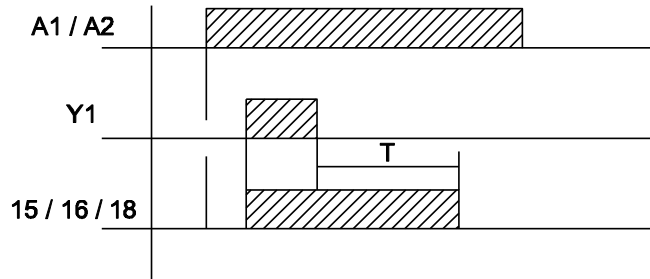

KM1 TO KM4 CONTACTORS.

Ith: 20 Amp.

UI: 690 V.

CONTROL ELEMENTS 2 RL-30

SK-4845



Philadelphia, PA 19135
(215) 624-4800
FAX (215) 624-6966

DRWN/DATE
DBC
10.12.06

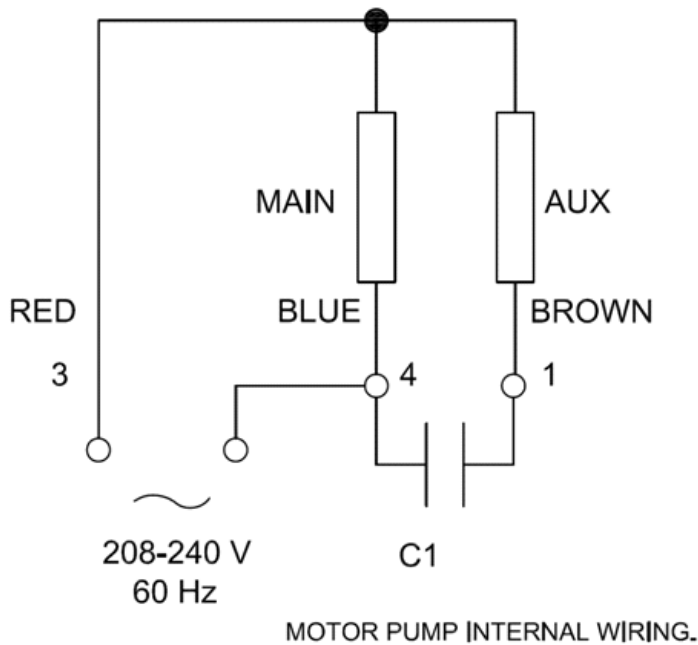

See SK-4987 for unit wiring

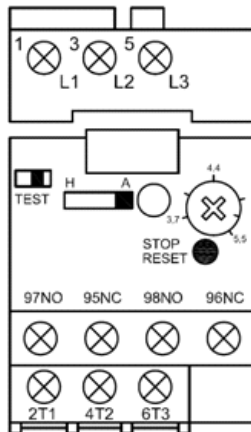

K1 THERMAL RELAY.
LR2 K0314
5,5 - 8 Amp

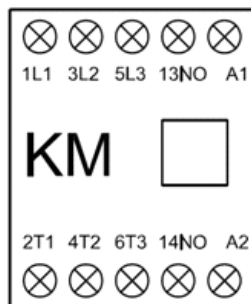

KM1 TO KM4 CONTACTORS.
Ith: 20 Amp.
Ui: 690 V.

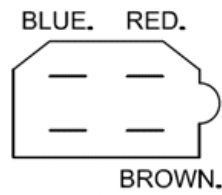

MOTOR PLUG.
"A" VIEW

"A"

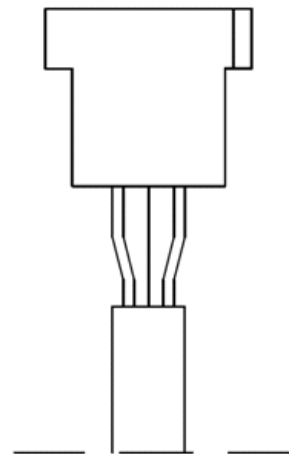

CONTROL ELEMENTS 3 RL-30

SK-4846



Philadelphia, PA 19135
(215) 624-4800
FAX (215) 624-6966

DRWN/DATE
DBC
10.12.06

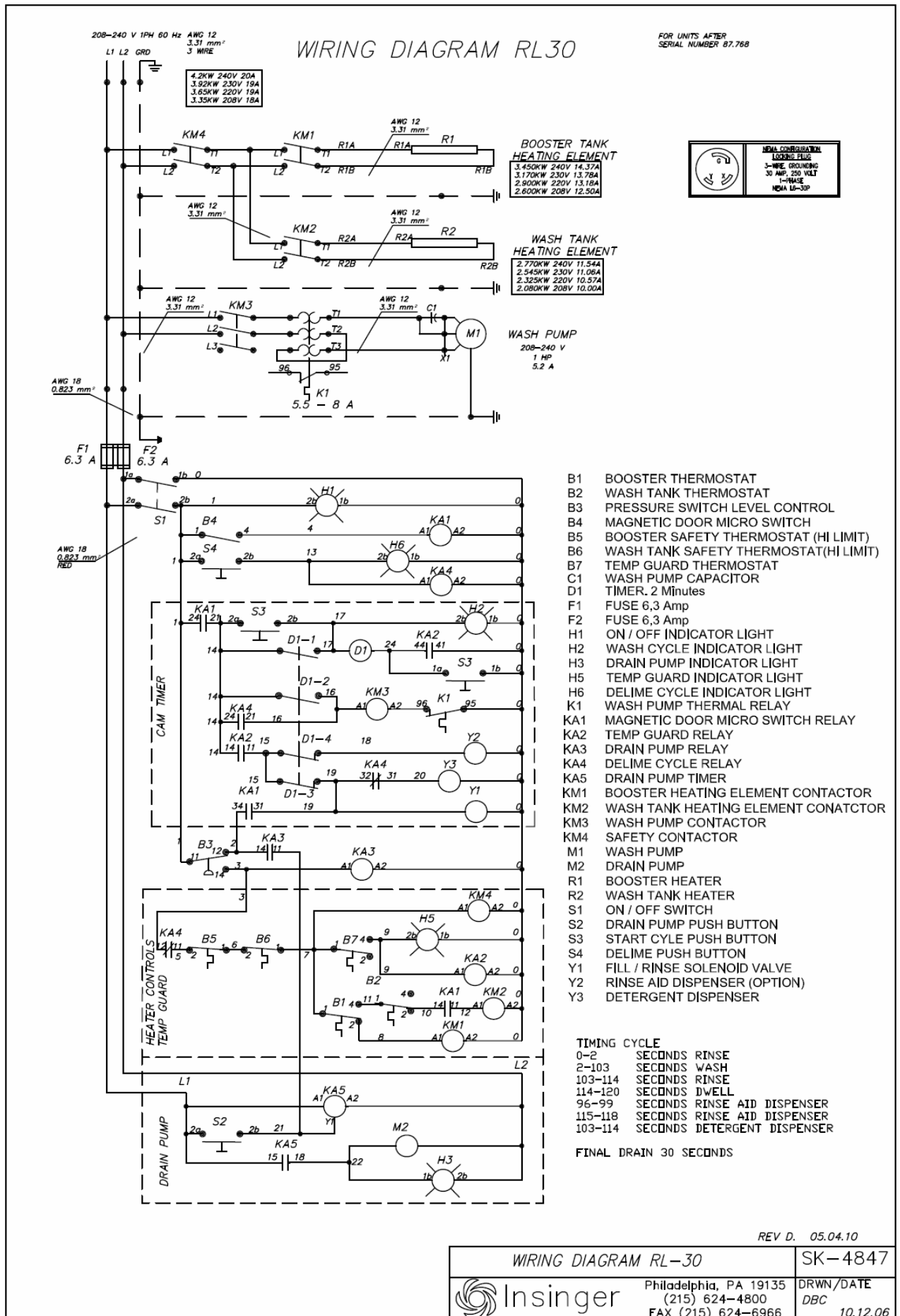

WIRING DIAGRAM HEATERS AND PUMP.

208-240 V 1Ph 60 Hz

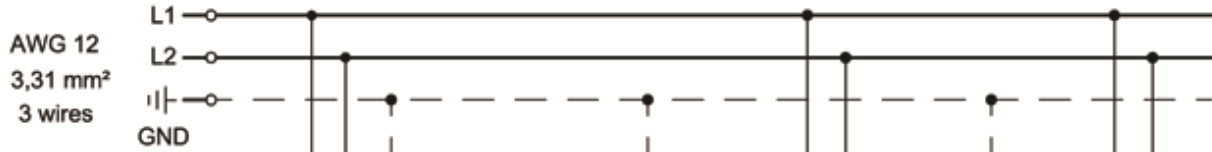

HIGH POWER.

4,20 KW 240 V 20 A
3,92 KW 230 V 19 A
3,65 KW 220 V 19 A
3,35 KW 208 V 18 A

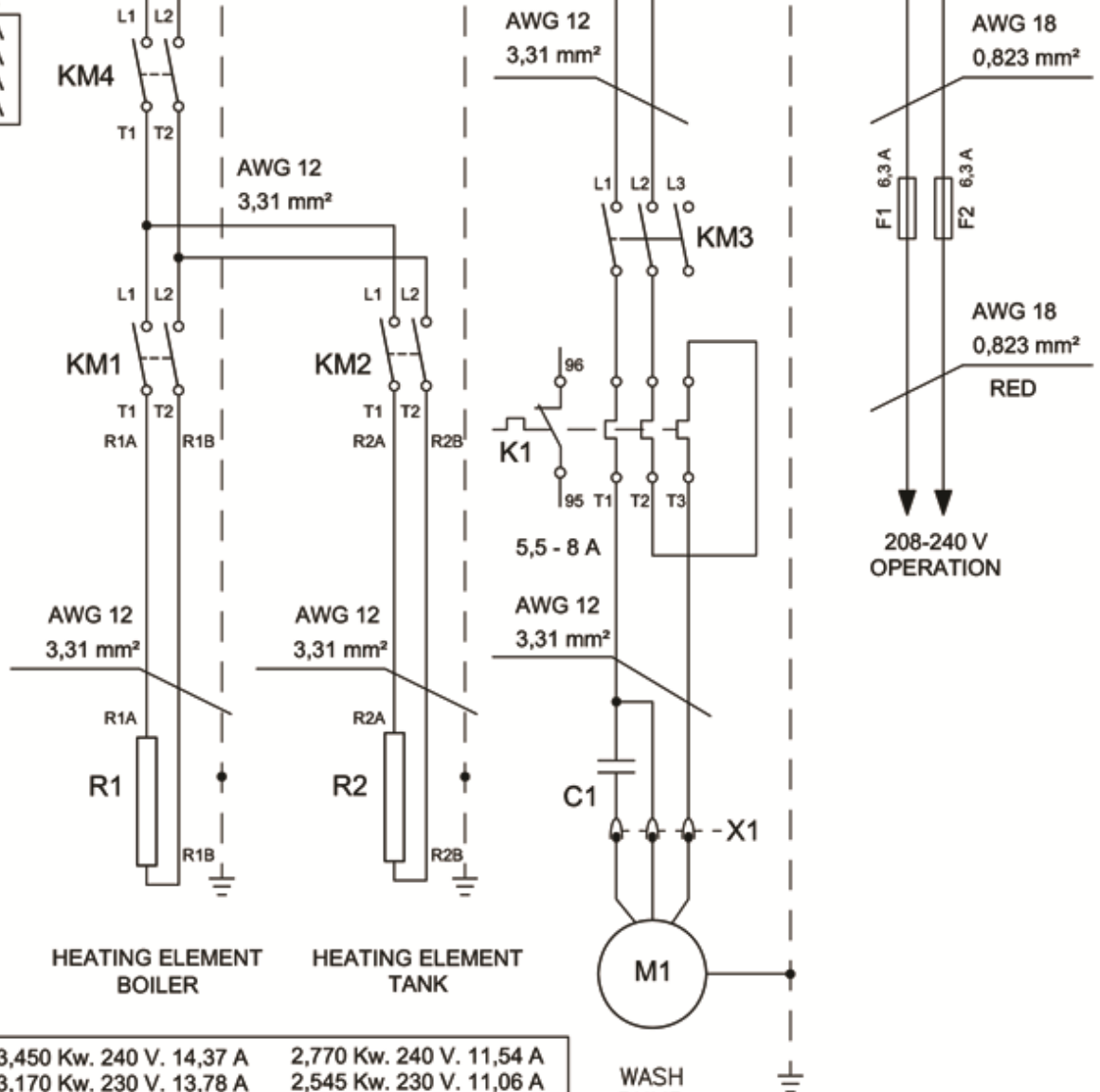

HEATING ELEMENT
BOILER

HEATING ELEMENT
TANK

HIGH POWER.

3,450 Kw. 240 V. 14,37 A	2,770 Kw. 240 V. 11,54 A
3,170 Kw. 230 V. 13,78 A	2,545 Kw. 230 V. 11,06 A
2,900 Kw. 220 V. 13,18 A	2,325 Kw. 220 V. 10,57 A
2,600 Kw. 208 V. 12,50 A	2,080 Kw. 208 V. 10,00 A

WASH
PUMP
208-240 V
1 HP.
5,2 A

WIRING DIAGRAM INDEX RL-30

B1	BOILER THERMOSTAT
B2	TANK THERMOSTAT
B3	PRESSURE SWITCH LEVEL CONTROL
B4	MAGNETIC DOOR MICRO SWITCH
B5	BOOSTER SAFETY THERMOSTAT
B6	TANK SAFETY THERMOSTAT
B7	TEMP-GUARD THERMOSTAT
C1	WASH PUMP CONDENSER
D1	TIMER 2 Minutes
F1	FUSE 6,3 Amp.
F2	FUSE 6,3 Amp.
H1	ON / OFF INDICATOR LIGHT
H2	WASH CYCLE INDICATOR LIGHT
H3	DRAIN PUMP INDICATOR LIGHT
H5	TEMPERATURES OK! INDICATOR LIGHT
H6	DELIME CYCLE INDICATOR LIGHT
K1	WASH PUMP THERMAL RELAY
KA1	MAGNETIC DOOR MICRO SWITCH RELAY
KA2	TEMP-GUARD RELAY
KA3	DRAIN PUMP RELAY
KA4	DELIME CYCLE RELAY
KA5	DRAIN PUMP TIMER
KM1	BOILER HEATING ELEMENT CONTACTOR
KM2	TANK HEATING ELEMENT CONTACTOR
KM3	WASH PUMP CONTACTOR
KM4	SAFETY CONTACTOR
M1	WASH PUMP
M2	DRAIN PUMP
M3	BOOSTER PUMP (OPTION)
R1	BOILER HEATER
R2	TANK HEATER
S1	ON / OFF SWITCH
S2	DRAIN PUMP PUSH BUTTON
S3	START CYCLE PUSH BUTTON
S4	DELIME PUSH BUTTON
Y1	FILL / RINSE SOLENOID VALVE
Y2	RINSE AID DISPENSER (OPTION)
Y3	DETERGENT DISPENSER

TIMER DIAGRAM RL-30

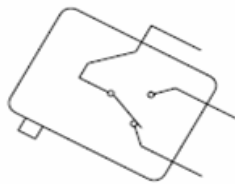
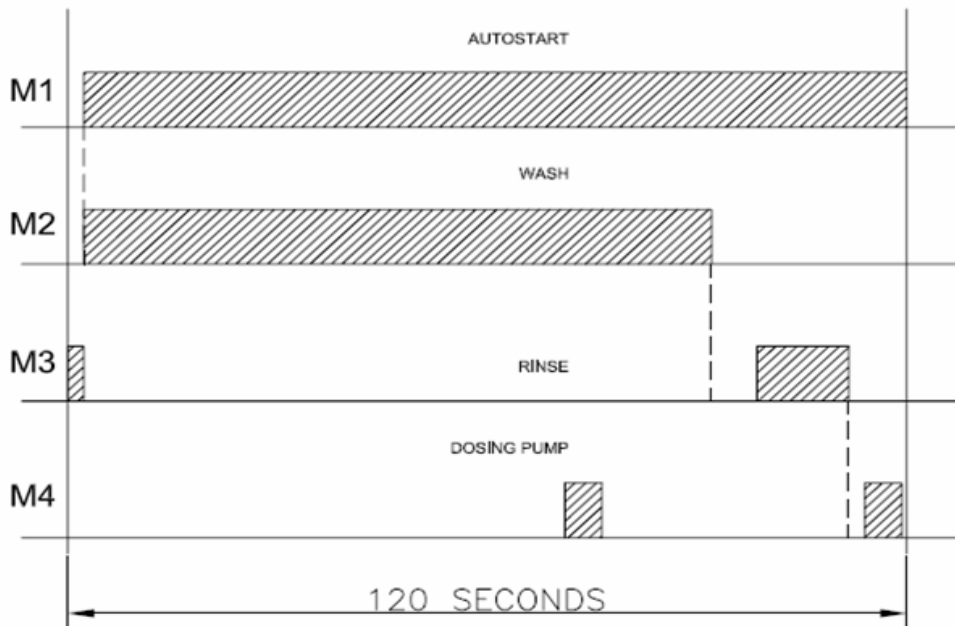

TIMER
CONTACTS
NORMALLY OPEN

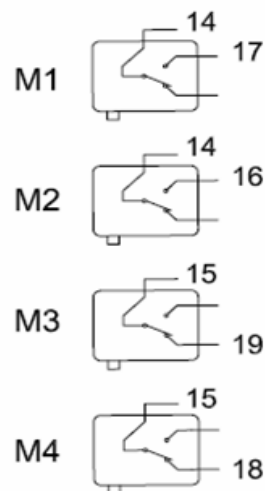
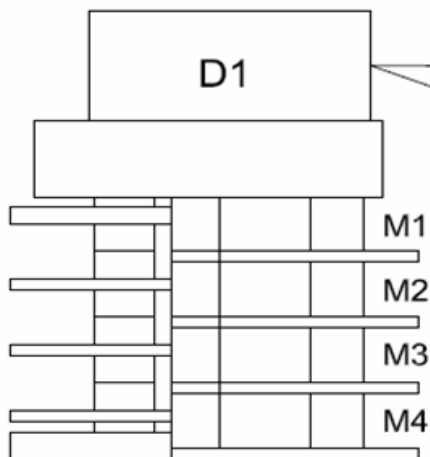

<i>E-TIMER RL-30</i>		SK-4850
 Insinger	Philadelphia, PA 19135 (215) 624-4800	DRWN/DATE
	FAX (215) 624-6966	<i>DBC</i> 10.12.06

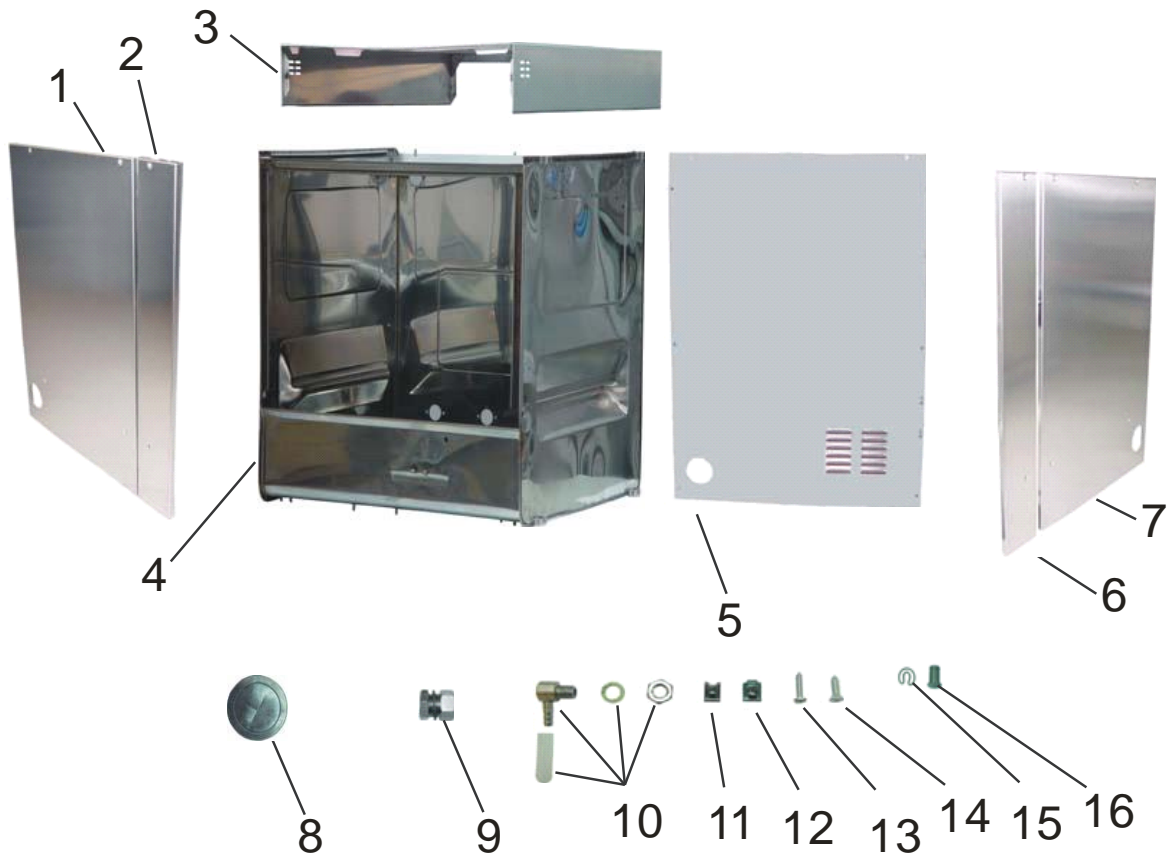

Pos.	Designation	Part no.
1	Big left panel RL-30 753,6x538x17 mm.	RL0516321
2	Strait left panel RL-30 753,6x92,1x20 mm.	RL0516319
3	Cover plate RL-30 575x715x85 mm.	RL0503121
4	Housing RL-30 442.5x529x481 mm.	RL0501130
5	Rear panel RL-30 575x812 mm.	RL0508221
6	Strait right panel RL-30 753,6x92,1x20 mm.	RL0516320
7	Big right panel RL-30 753,6x538x17 mm.	RL0516322
8	Side cable pass RL-30	RL2530100
9	Tank thermometer fitting	RL0834118
10	Nipple detergent	RL0845120
11	Control panel fixing nut TR-1812-B	RL1536006
12	Fixing nut TR-522-2C	RL1536009
13	Stainless steel screw 2,9 x 16 * DIN7971	RL1515022
14	Stainless steel screw 4,2x16 * DIN 7983	RL1515069
15	Anular washer 8 m/m	RL1599006
16	Threaded cap	RL1522200

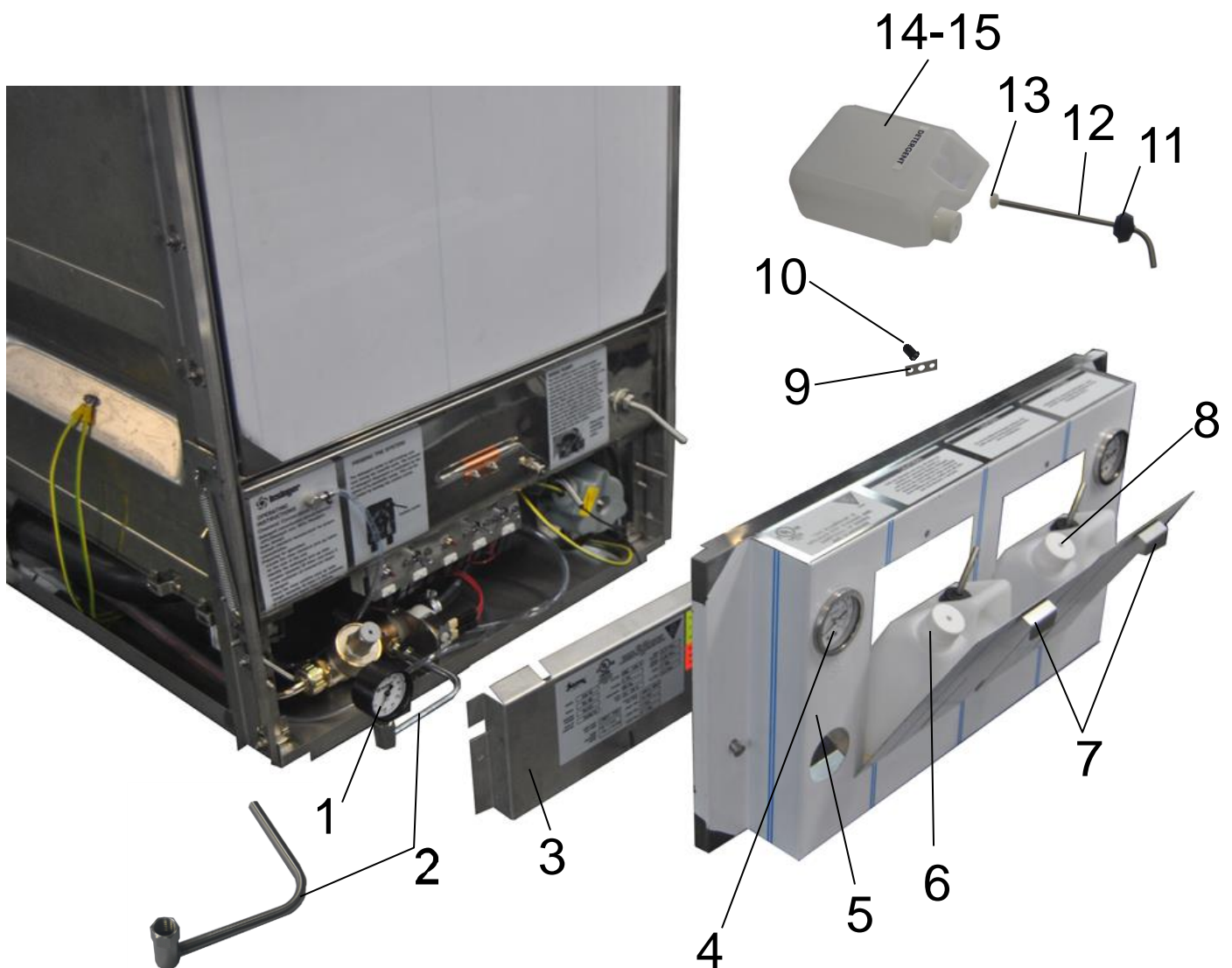

Pos.	Designation	Part no.
1	Pressure gauge	RL1026118
2	Pressure gauge tube	RL1010038
3	Cover to accede to the lower part 495x135x30 mm.	RL0508400
4	Thermometer 0-105 °C / 20-220 °F	RL2028018
5	Lower front panel 575x295x85 mm.	RL0504250
6	Complet detergent deposit	RL4031115
7	Cover to accede to the deposits	RL0507400
8	Complet rinse liquid deposit	RL4031110
9	Magnet support	RL5543500
10	Magnet	RL2019130
11	Cap	RL2530120
12	Stainless steel pipe	RL0852090
13	Filter	RL4082009
14	Detergent deposit	RL4031009
15	Rinse liquid deposit	RL4031010

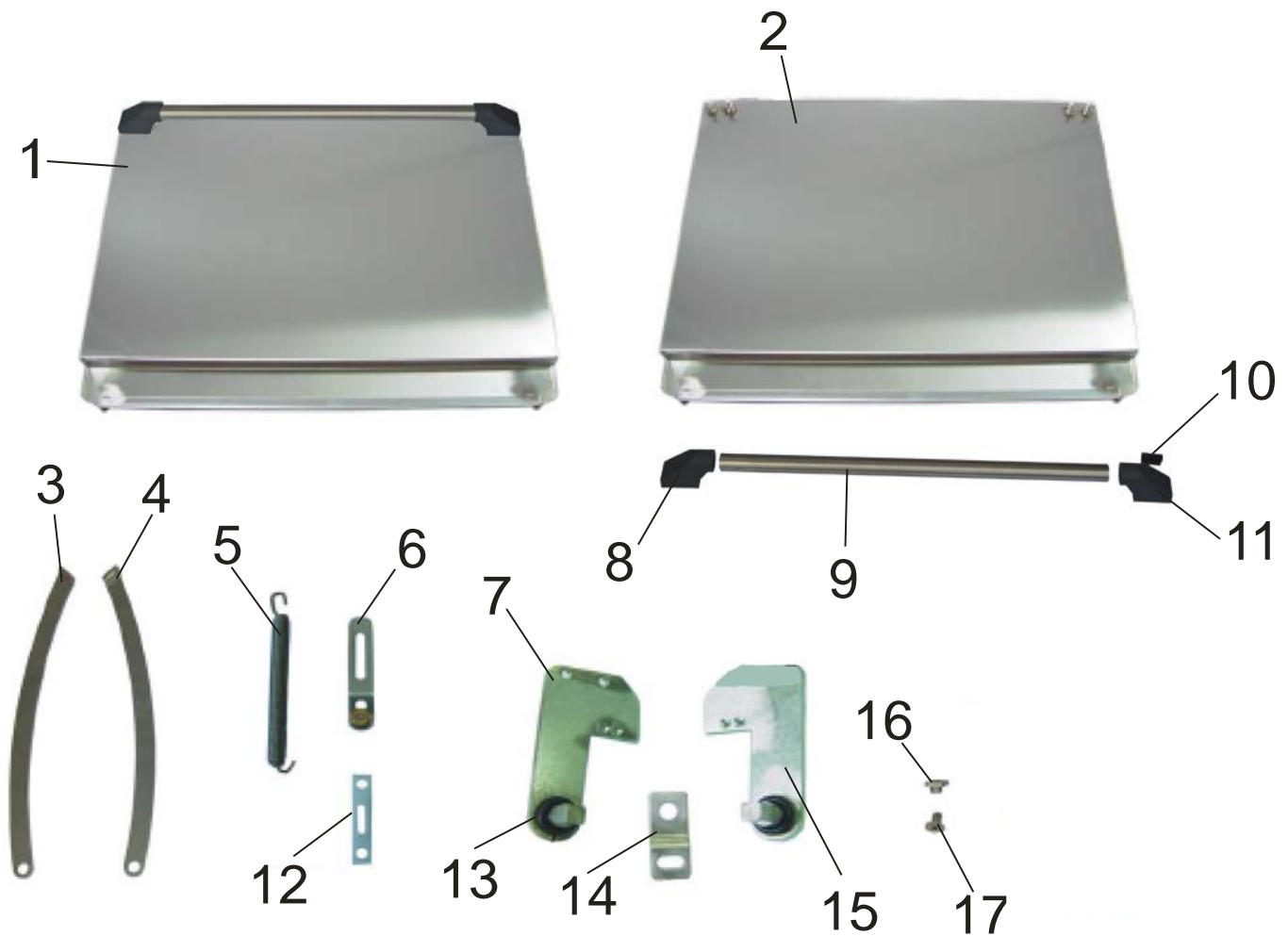

Pos.	Designation	Part no.
1	Complete door RL-30 534,6x470 mm.	RL1405646
2	Door RL-30 534,6x470 mm.	RL0507121
3	Left door brace	RL0849119
4	Right door brace	RL0849120
5	Door spring	RL2521120
6	Door spring tensor	RL0844119
7	Left door hinge	RL0805219
8	Handle support (left)	RL4080020
9	Door andel L= 445 mm.	RL0510119
10	Magnet	RL2019120
11	Handle support (right)	RL4080023
12	Door brace guide	RL4038019
13	O ring 7x3x13 mm.	RL2514010
14	Hinge support	RL5519120
15	Right door hinge	RL0805221
16	Hexagonal nut	RL1521219
17	Screw	RL1515619

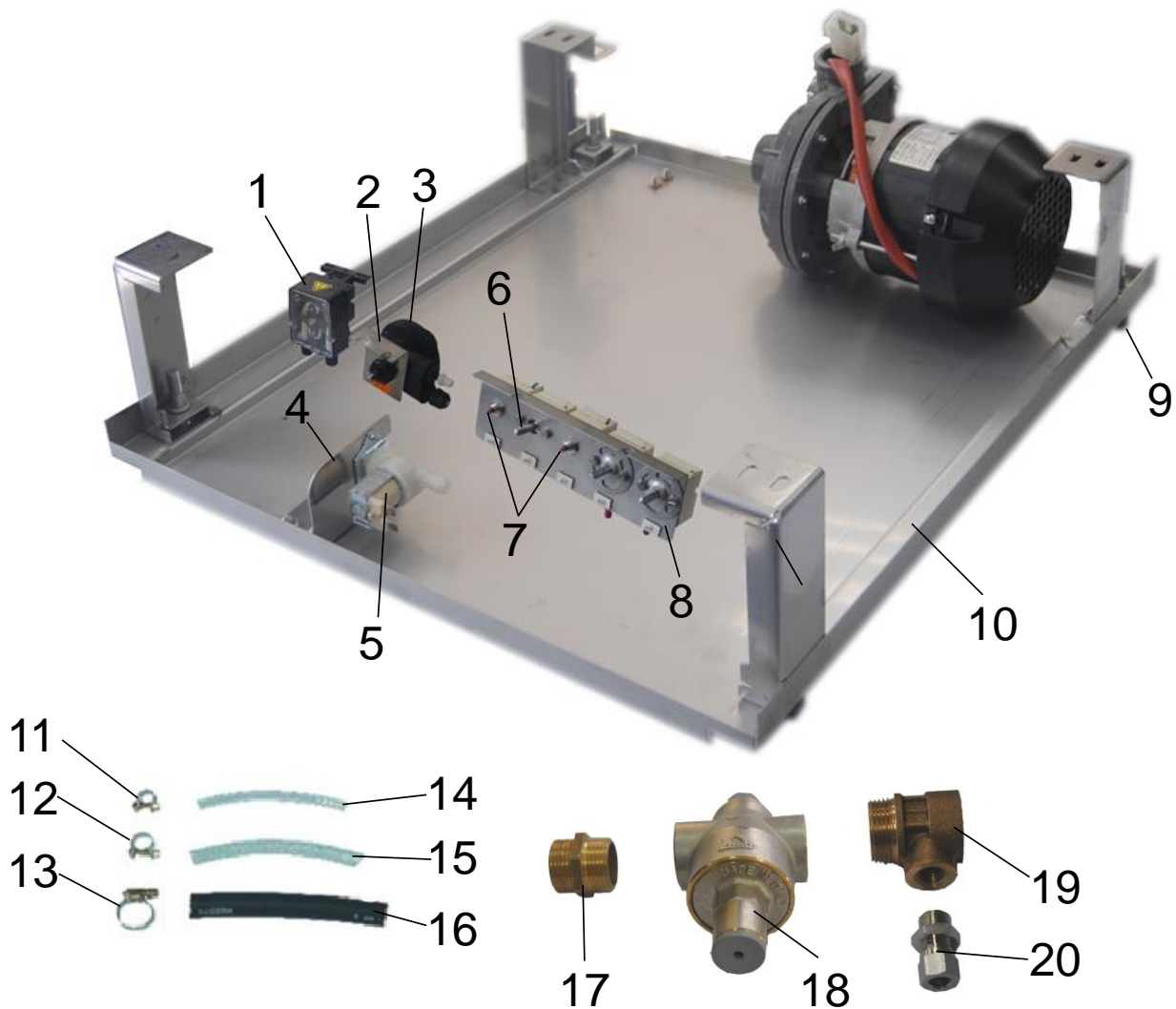

Pos.	Designation	Part no.
1	Detergent Dispenser	RL2031080
2	Rinse liquid dispenser support	RL5543119
3	Rinse liquid dispenser	RL2031101
4	Solenoid valve support	RL5543120
5	Solenoid valve 220/240V. a 50 – 60 Hz.	RL2017006
6	Thermostat 93°C.	RL2006053
7	Safety thermostat 140°C.	RL2006062
8	Thermostat support inox. 5 Thermostats	RL5543117
9	Feet L= 60 mm.	RL4027102
10	Frame 545x610x155 mm.	RL0506130
11	Hose clip 9,5-10	RL2501003
12	Hose clip 12-13	RL2501006
13	Hose clip 12-22	RL2501008
14	PVC 6x9 length 800 mm. (detergent)	RL1010210
15	Hose 6x12 length 450 mm. (rinse)	RL1010220
16	Hose ø 12mm length 810 mm. (water)	RL1012012
17	Juntion piece F280	RL1013090
18	Pressure regulator water inlet	RL1009220
19	¾ connection for pressure gauge	RL1014018
20	Juntion piece	RL1014025

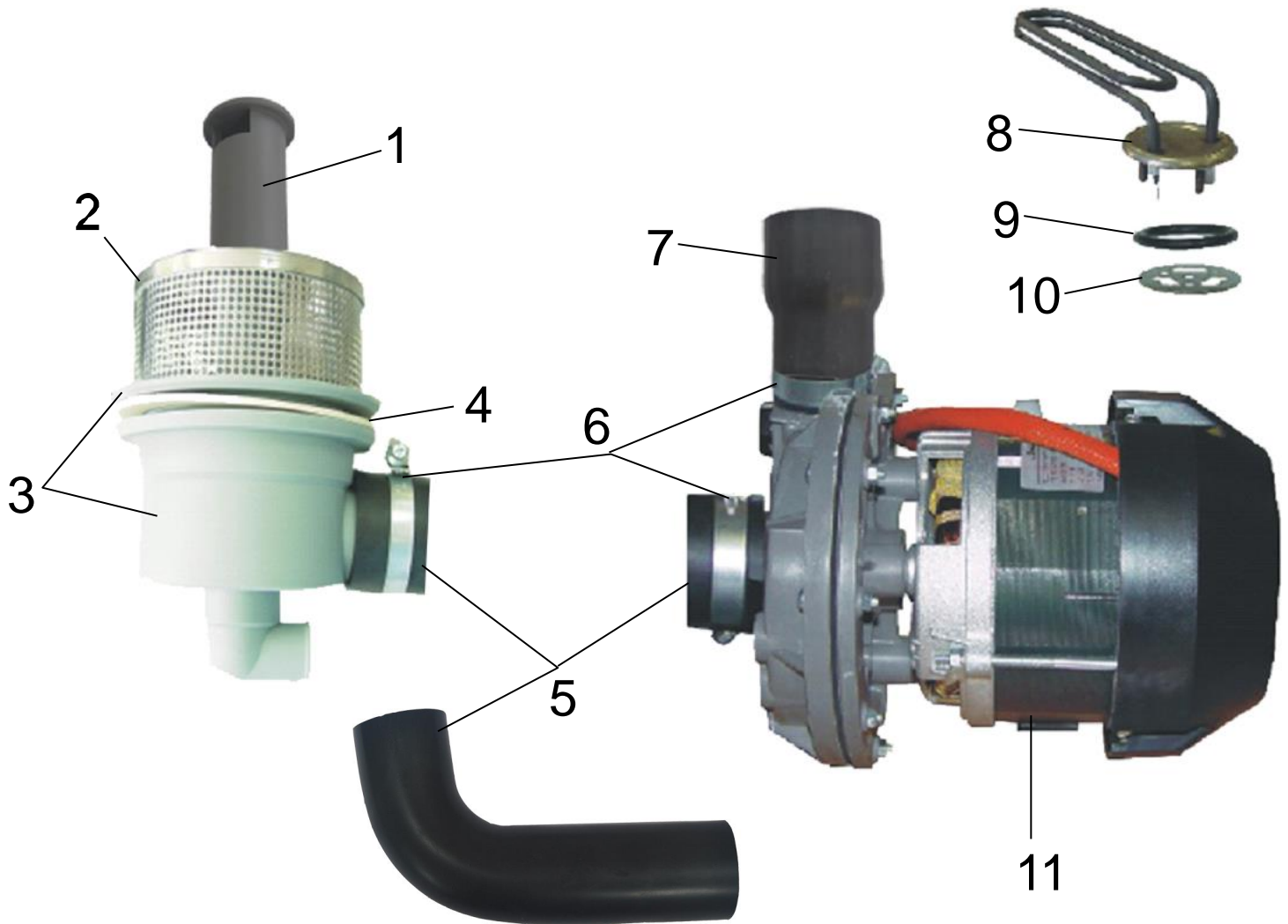
05 WASHING ZONE RL-30

Pos.	Designation	Part no.
1	Stand pipe overflow (open) L=205	RL1016118
2	Metal filter GS-18/19 Ø 125x58 mm.	RL0522119
3	Complete drain collector GS-18/19	RL1009257
4	O-ring	RL2510325
5	Hose elbow (pump-collector) GS-18/19 Ø 45 mm.	RL1008019
6	Hose clip 40/60	RL2501090
7	Hose Ø 40 / 50 mm. L=75 mm.	RL1012104
8	Heating element 2400W. – 208V.	RL2001405
9	O-ring	RL2514180
10	Clamping plate	RL5537004
11	Complete wash pump 208-240 V. 1Ph 60Hz. (1HP)	RL2011121

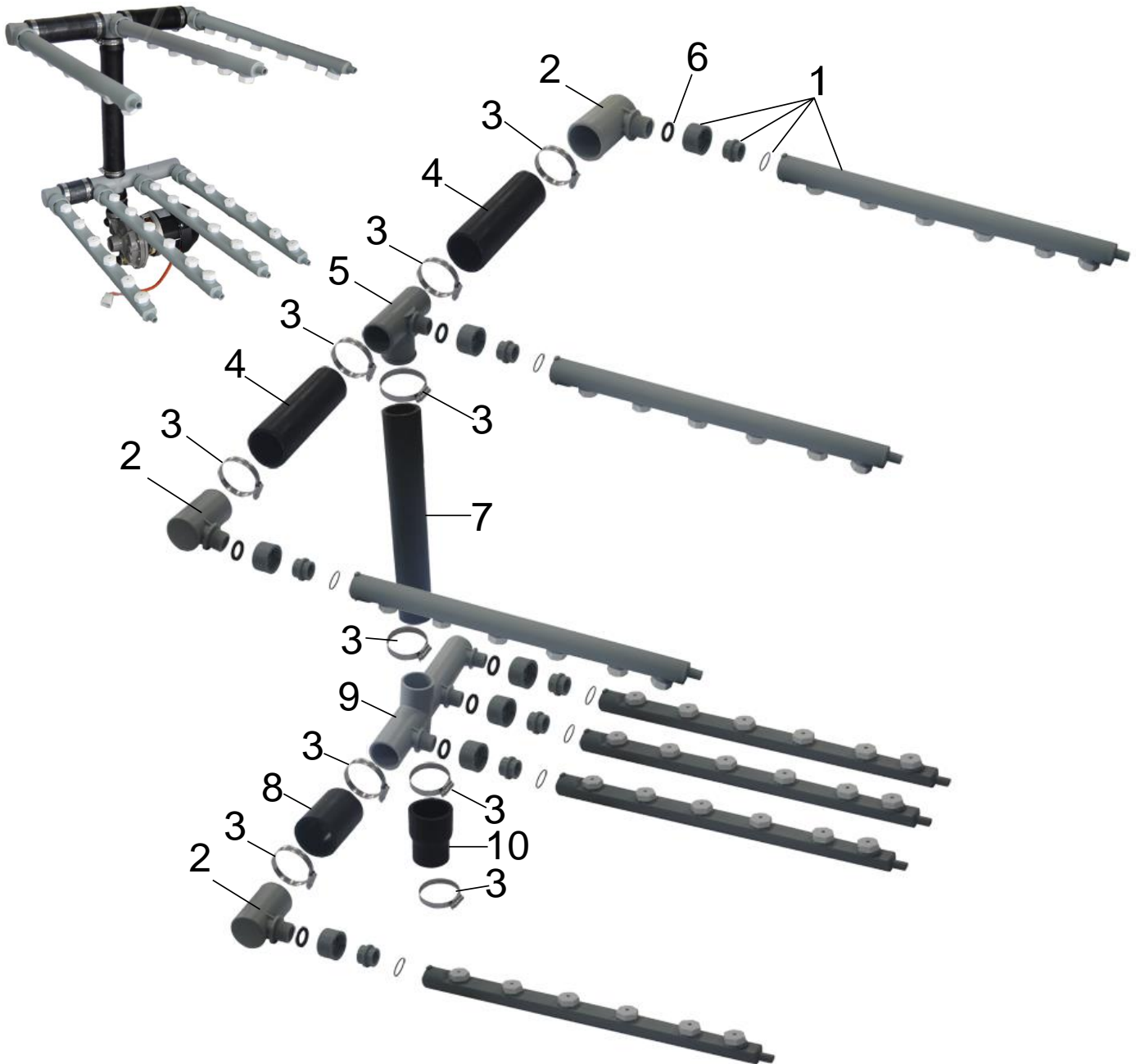

Pos.	Designation	Part no.
1	Complete wash arm L=500 mm.	RL8040119
2	Lateral part manifold	RL4035160
3	Hose clip 40-60	RL2501090
4	Hose piece Ø 48 mm. L=175 mm.	RL1012517
5	Central part manifold	RL4035161
6	O-ring 36x24x4 mm	RL2410020
X*	Complete wash manifold sup. (with ref. 2,3,4,5,6)	RL4035075
7	Hose piece Ø 58 L=410 mm.	RL1012537
8	Hose piece Ø 48 L=75 mm.	RL1012120
9	Cogger wash manifold	RL4035072
Y*	Complete wash manifold inf. (With ref. 2,3,8,9)	RL4035076
10	Pump hose piece Ø 40 / 50 mm. L=75 mm.	RL1012104

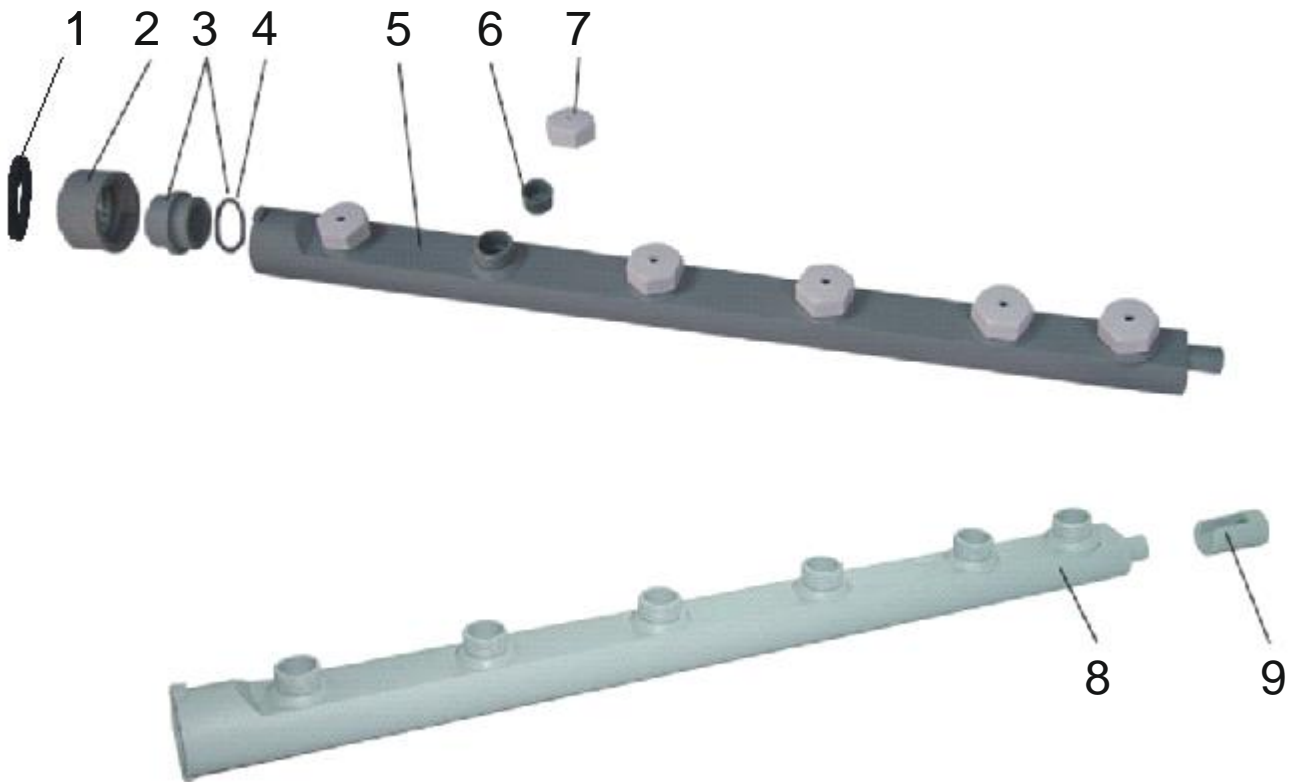
07 WASH ARM RL-30

Pos.	Designation	Part no.
1	O-ring 36x24x4 mm	RL2510020
2	Lock ring	RL4050120
3	Locking nut + o-ring 28x33x2 mm.	RL4050119
4	O-ring 28x33x2	RL2514091
5	Wash arm complete L=500 mm.	RL8040119
6	Propeller for nozzle	RL4032122
7	Nozzle Ø 5mm (white color)	RL4032119
8	Wash arm (without 5 and 6) L=500 mm.	RL4028119
9	Guide support for wash arm	RL4080183

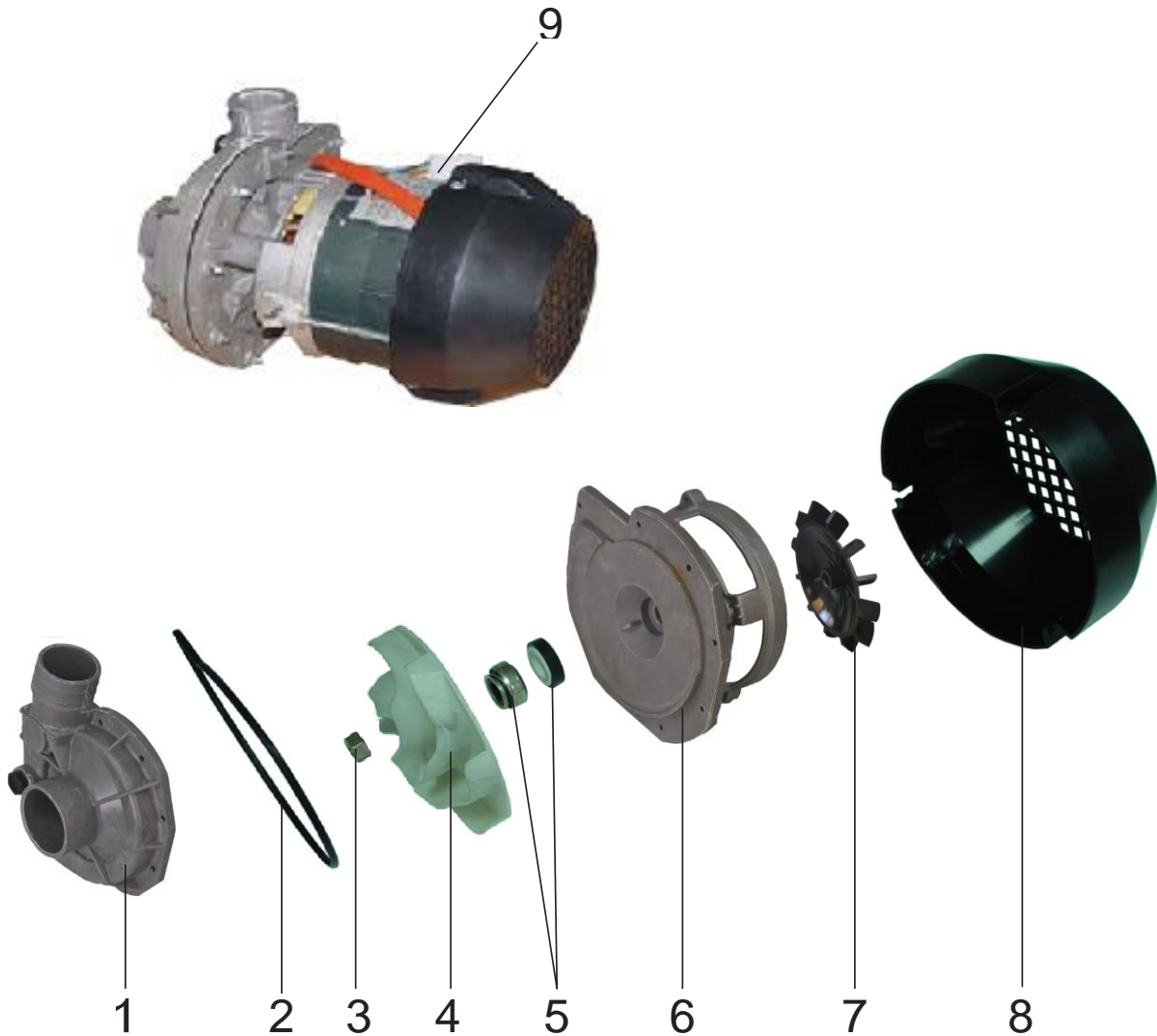
08 WASHING PUMP RL-30

Pos.	Designation	Part no.
1	Pump housing	RL4032118
2	O-ring	RL2516118
3	Nut M-6 I for pump shaft	RL1541016
4	Impeller for pump 60 Hz.	RL4042318
5	Seating ring / motor shaft seal	RL2041118
6	Wash pump	RL4037118
7	Fan	RL4043119
8	Fan cover	RL0842121
9	Complete wash pump (208-240, 1PH, 60 HZ, 1 HP)	RL2011121

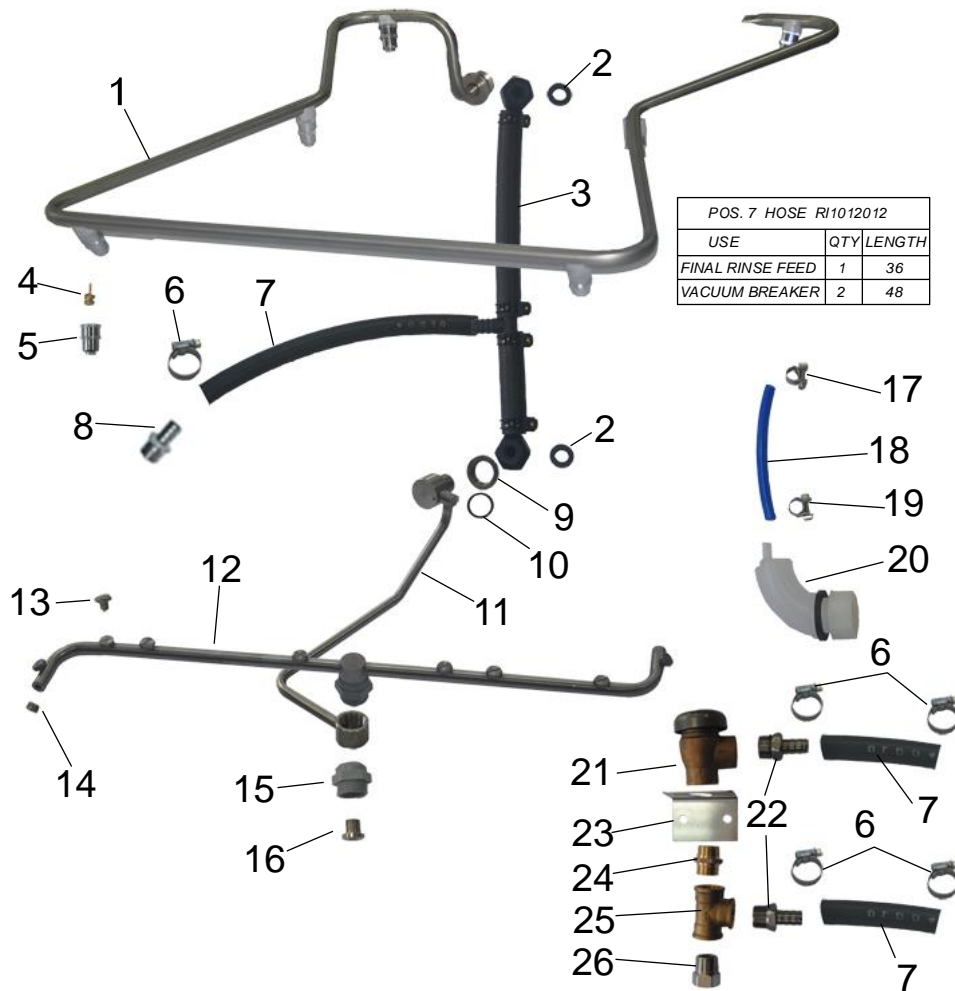

Pos.	Designation	Part no.
1	Rinse manifold	RL0817120
2	Seal 18x10x2	RL2510012
3	Hose and fitting for rinse manifold	RL1012137
4	Spray jet swirl	RL0832006
5	Spray jet cap	RL0843007
6	Hose clip 12-22	RL2501008
7	Hose Ø 12 mm.	RL1012012
8	Outlet boiler fitting (stainless steel)3/8"	RL0845090
9	Locking nut 1/2"	RL1525203
10	O-ring 20x25x2,5	RL2514081
11	Revolving rinse arm support	RL0840219
12	Complete revolving arm	RL0807109
13	Flat set nozzle	RL0841040
14	Revolving arm end screw	RL1515609
15	Plastic revolving arm bush (white)	RL4047002
16	Fastening screw for revolving arm	RL1515608
17	Hose clip 9 mm.	RL2501002
18	Hose PVC 5x9 mm. blue	RL1010202
19	Hose clip 9,5-10 mm.	RL2501003
20	Air chamber	RL4055001
21	Atmospheric Vacuum Breaker	RL1009281
22	Rinse hose fitting	RL1014019
23	Atmospheric Vacuum Breaker support	RL5543187
24	Juntion piece	RL1013101
25	Juntion "T"	RL1019050
26	Raccord	RL0834115

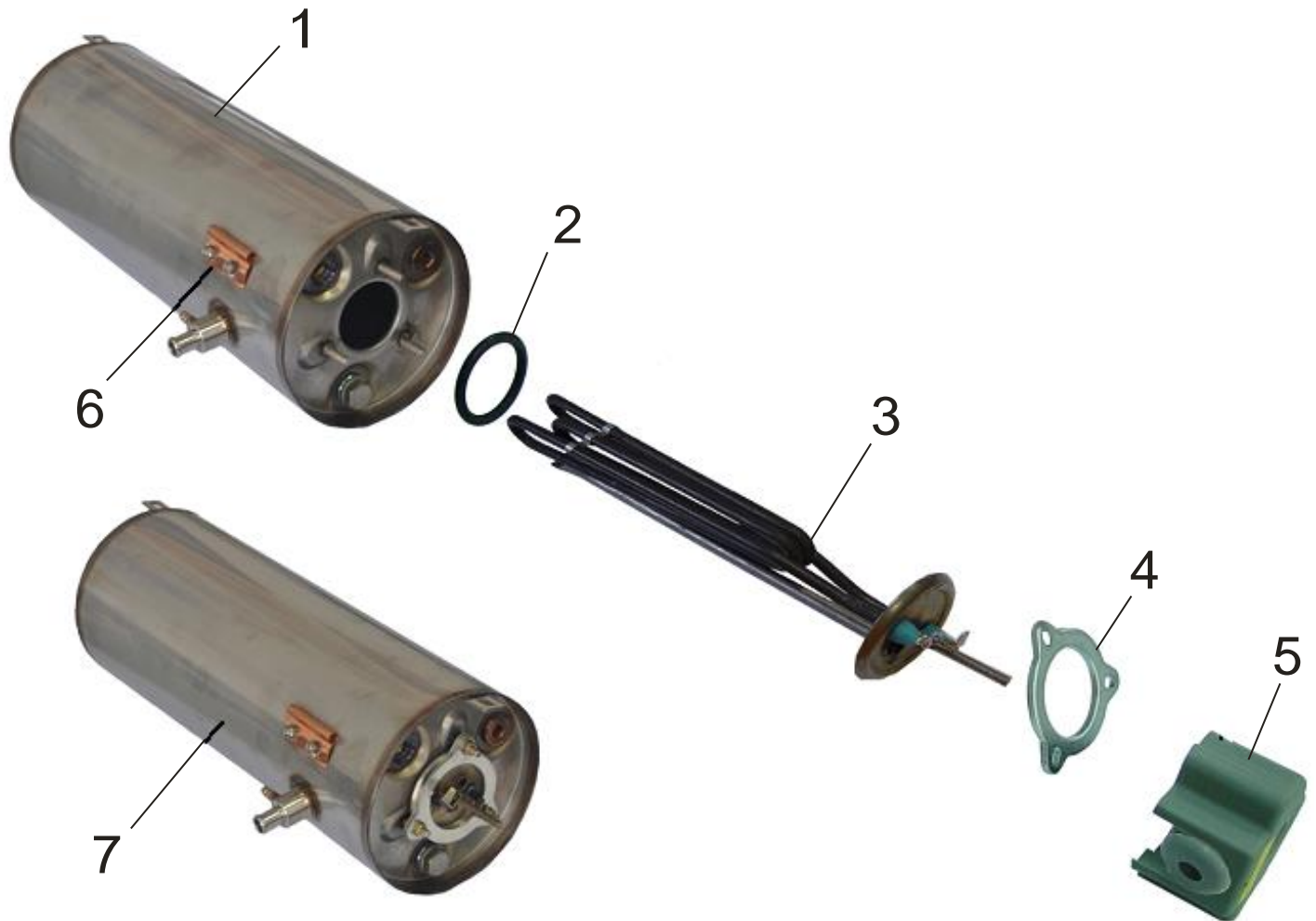
10 BOILER RL-30

Pos.	Designation	Part no.
1	Boiler L= 360 mm.	RL0502025
2	O-ring	RL2514180
3	Heating element single phase 2,6-3,45KW. / 208-240V.	RL2001402
4	Clamping plate	RL5537005
5	Heating element cap	RL1420090
6	Thermostat fixing	RL0712001
7	Boiler with heating element	RL1405119

11 CONTROL PANEL RL-30 (FOR UNITS AFTER DECEMBER 2016)

Pos.	Designation	Part no.
1	Complete control panel RL-30 570x105 mm.	RL1420556
2	Control panel RL-30 570x105 mm.	RL0504643
3	Frontal panel embellish cover left side	RL4032519
4	Insinger label	RL3007030
5	Control panel label	RL3007032
6	Frontal panel embellish cover right side	RL4032520
7	Switch button	RL2002150
8	Push button	RL2003150
9	Push and switch button support	RL2034150
10	Button blue	RL2016150
11	Button green	RL2016151
12	White led light	RL2014150
13	Blue led light	RL2014151
14	Green led light	RL2014152

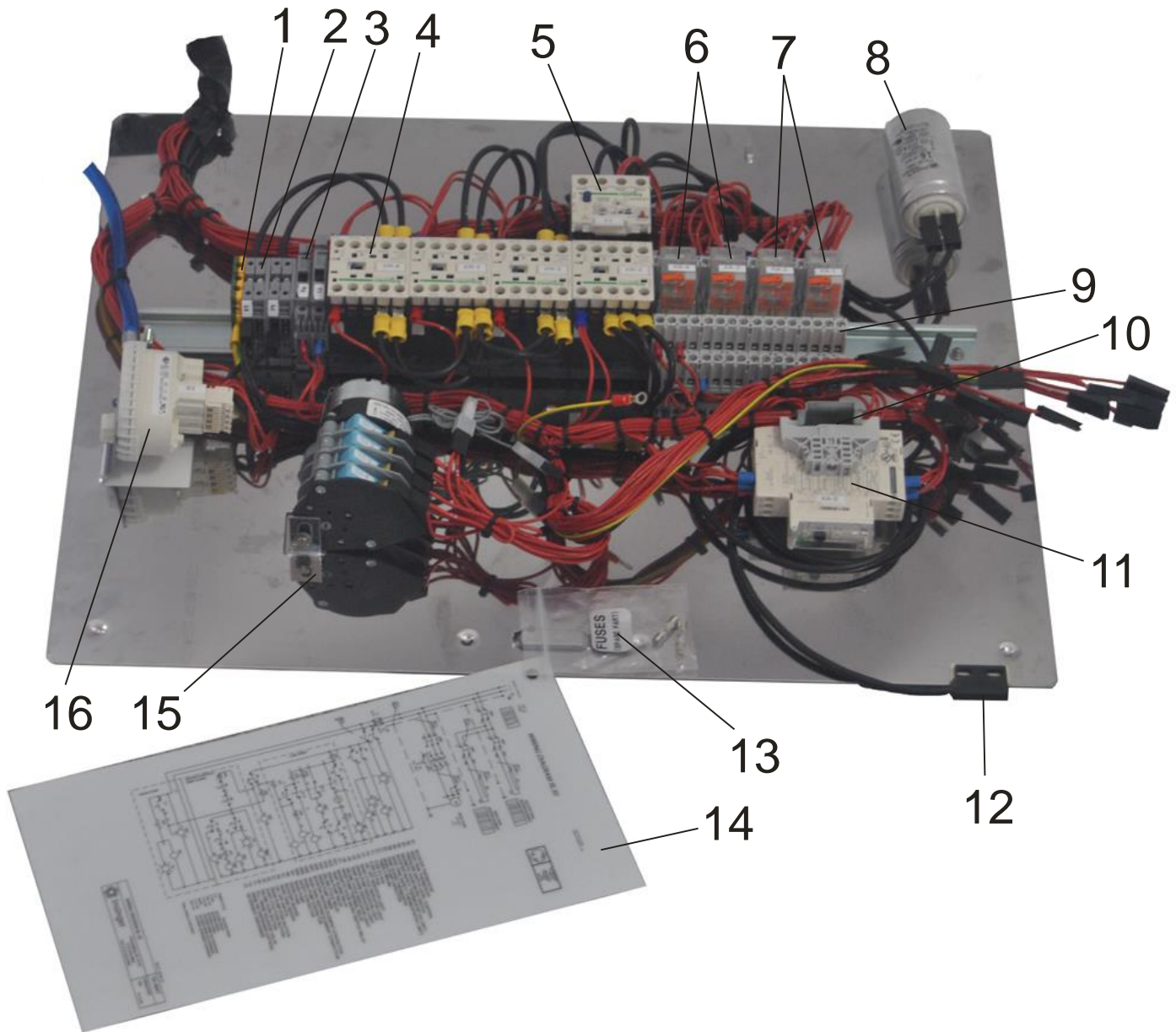
12 ELECTRICAL PANEL RL-30

Pos.	Designation	Part no.
1	Herat terminal E-165113.16	RL2020015
2	Block 4 faston E-115191.03	RL2021002
3	Fuse holder block E-115622.22 + Fuse	RL2021003
4	Contactor 230V. * LC1K0910M7	RL2008321
5	Thermal relay LR2K0314 5,5-8A	RL2022638
6	Feed relay 230V. 50-60 Hz. RLX2A 12A. 250V.	RL2054010
7	Feed relay 230V. 50-60Hz. 4NANC 12A. 250V.	RL2054083
8	Condenser 16µF	RL2013020
9	Feed relay base.	RL2054084
10	End dock E-1030002.26	RL2051085
11	Timing device 8 A/ 250V. 50-60 Hz.	RL2054101
12	Door magnetic micro switch	RL2019122
13	Bag fuses spare part (x2) Fuse 6,3 Amp. "UL"	RL2023004
14	Wiring diagram	RL6016220
15	Timer 230V. 50-60 Hz.	RL2005056
16	Level switch	RL2007011

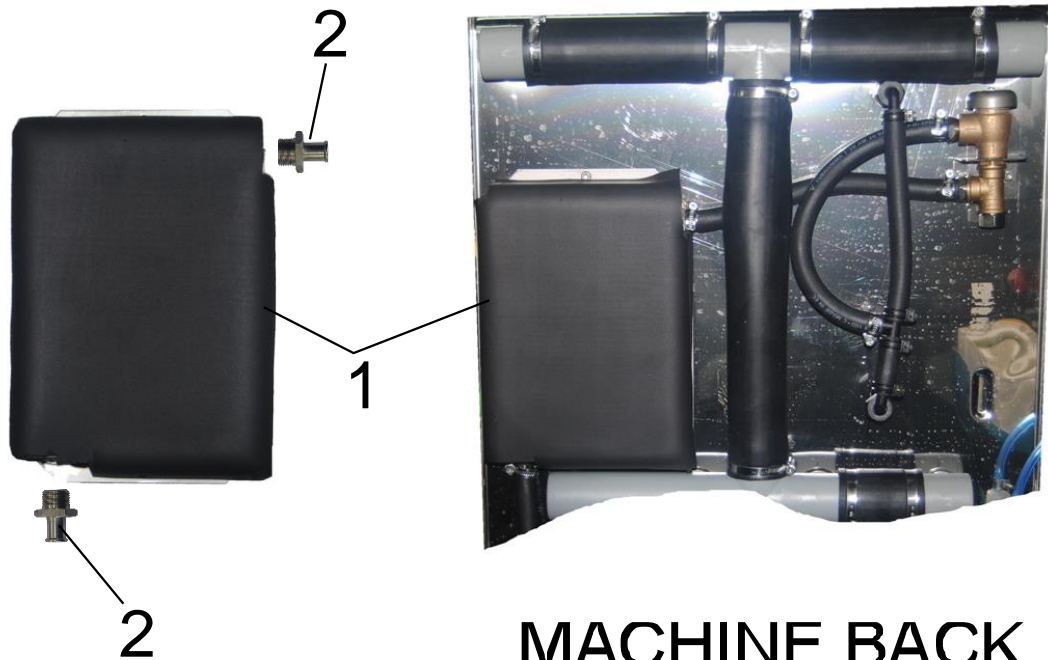
13 MACHINE BACK VIEW RL-30

**MACHINE BACK
VIEW**

Pos.	Designation	Part no.
1	Bag tank	RL0501601
2	Rinse hose fitting 22x3/8	RL0845090

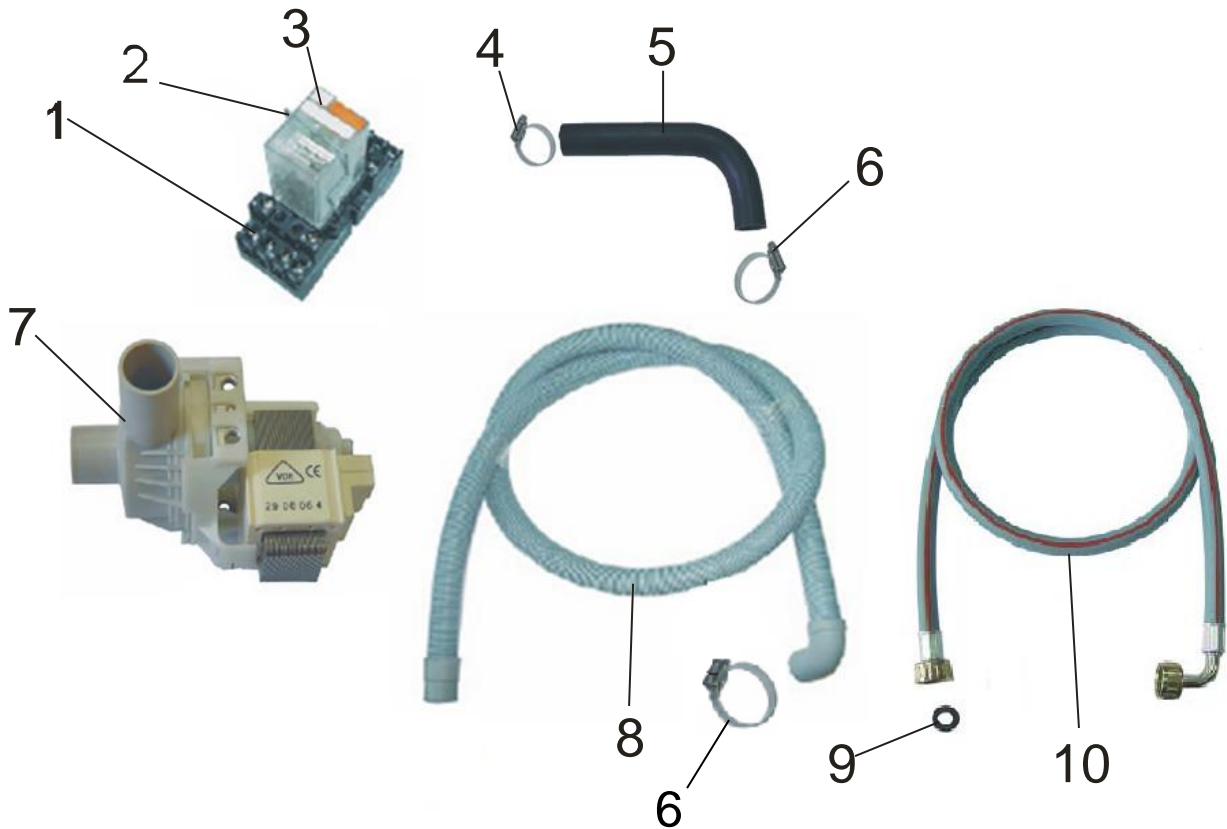
14 DRAIN PUMP AND INLET WATER RL-30

Pos.	Designation	Part no.
1	Feed relay base	RL2054084
2	Clip for fixing relay	RL2054085
3	Feed relay 230V. 50-60 Hz. RLX2A 12A.	RL2054010
4	Hose clip 25-40	RL2501047
5	Hose elbow	RL1008034
6	Hose clip 20-32	RL2501038
7	Drain pump 200-240 V 50-60 Hz.	RL2030018
8	Drain hose Ø 20 L=1530 mm.	RL1010292
9	Hose ¾	RL2510001
10	Inlet water hose ¾	RL1012106

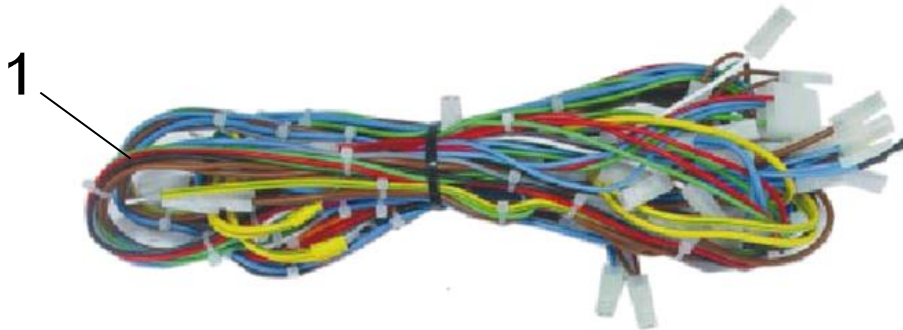
15 ELECTRICAL SYS RL-30

Pos.	Designation	Part no.
1	Single phase electric installation	2026118
2	Single phase electric current input	2026119

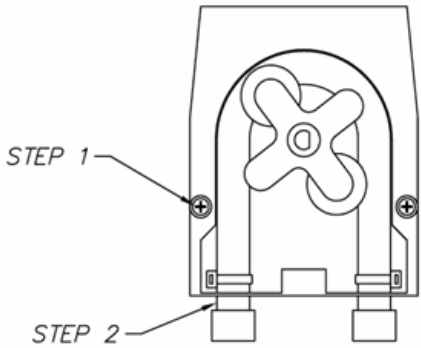

STEP 1: REMOVE (2) #4 x 1/4" LONG MACHINE SCREW & REMOVE CLEAR FRONT COVER.

STEP 2: PULL TUBING CONNECTORS, TUBING & SPIDER WHEEL ASSEMBLY STRAIGHT UP TO REMOVE FROM PUMP.

STEP 3: WRAP NEW TUBE ASSEMBLY AROUND SPIDER WHEEL ASSEMBLY. THE TUBE IS COATED WITH GREASE. DO NOT WIPE OFF.

STEP 4: REPLACE ASSEMBLY IN PUMP. ALIGN BLACK TUBING CONNECTORS IN SLOTS & ALIGN FLAT ON SPIDER WHEEL ASSEMBLY WITH FLAT ON MOTOR SHAFT. PUSH STRAIGHT DOWN. REPLACE FRONT COVER.

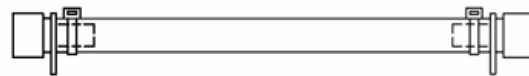
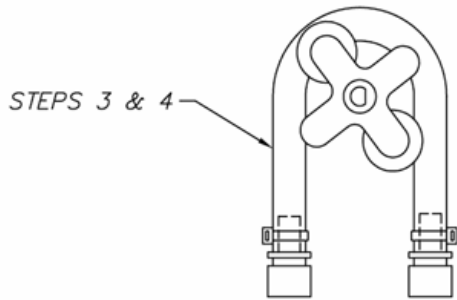

D3195 HOSE ASSEMBLY COATED WITH SILICON GREASE - 1 REQ'D

			TOLERANCES	TITLE	NEXT ASSY	DWG. NO.
			FRACTIONS ±1/64	REPLACEMENT HOSE KIT	RL2031080	1554-12
			DECIMALS	SEKO DETERGENT PUMP	REQ'D 1	
			.XXX ± .005	MAT'L	SCALE	USED ON
			.XX ± .01	NOTED	1=2	RL-30
			ANGLES ±1/2°	 Philadelphia, PA 19135 (215) 624-4800 FAX (215) 624-6966	DRWN/DATE	
REV	ECN NO	DATE	UNLESS OTHERWISE SPECIFIED		CES	
FILE: PARTS\1554-12						4.21.10

DETERGENT DISPENSER

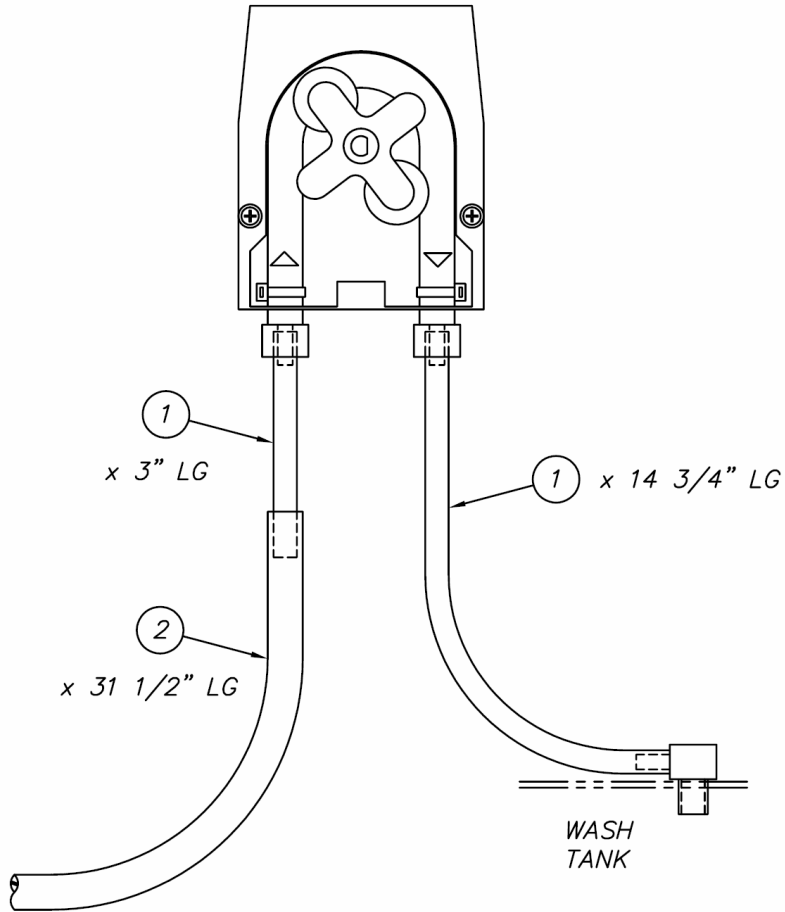

ITEM	PART NO.	DESCRIPTION	QTY.
1	D3059 (PART OF RL0845120)	PVC TUBE 4mm ID X 6mm OD	-
2	D3202 (RL1010210)	PVC TUBE 6mm ID X 9mm OD	-
3	D3200 (RL1010220)	BRAIDED HOSE 6mm ID X 12mm OD	-
4	D3196 (RL2501003)	HOSE CLAMP 9,5-10mm	-
5	D3197 (RL2501006)	HOSE CLAMP 12-13mm	-

RINSE DISPENSER

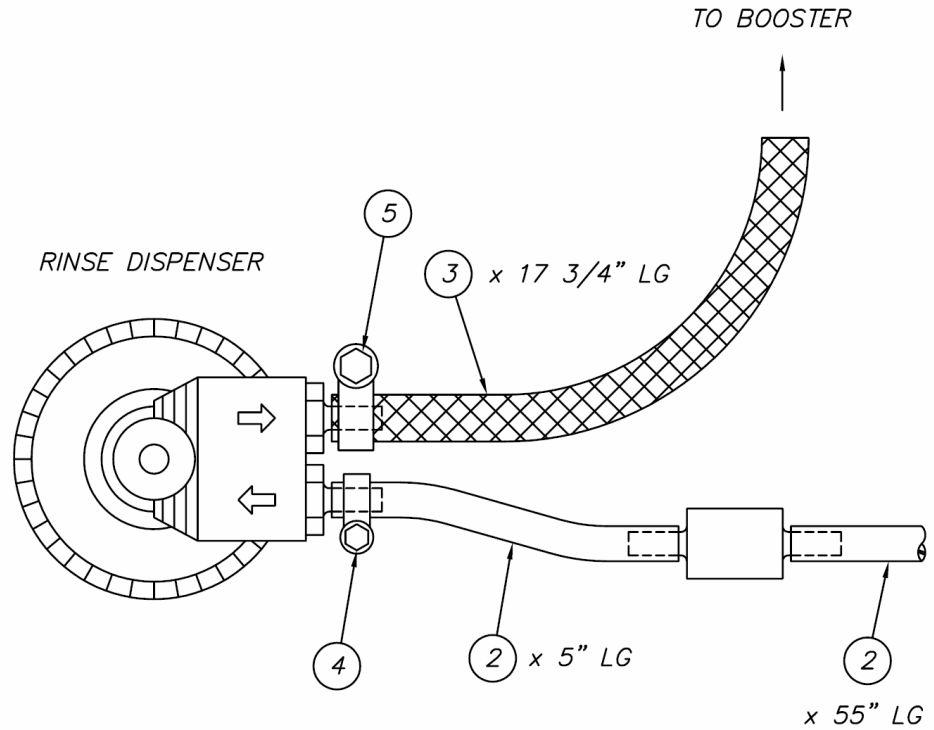

NOTE: 5mm X 8mm GS-302 TUBE CAN BE FORCED FITTED, BUT CONNECTION TO DETERGENT DISPENSER WILL BE IMPROPER.

REV	ECN NO	DATE	TOLERANCES
			FRACTIONS ±1/64
			DECIMALS
			.XXX ± .005
			.XX ± .01
			ANGLES ±1/2°
			UNLESS OTHERWISE SPECIFIED
FILE: PARTS\1554-13			

TITLE	NEXT ASSY	DWG. NO.
DETERGENT & RINSE HOSE CONNECTION DIAGRAM	-	1554-13
MAT'L	REQ'D -	USED ON RL-30
NOTED	SCALE 1=2	DRWN/DATE CES 5.4.10
 Philadelphia, PA 19135 (215) 624-4800 FAX (215) 624-6966		

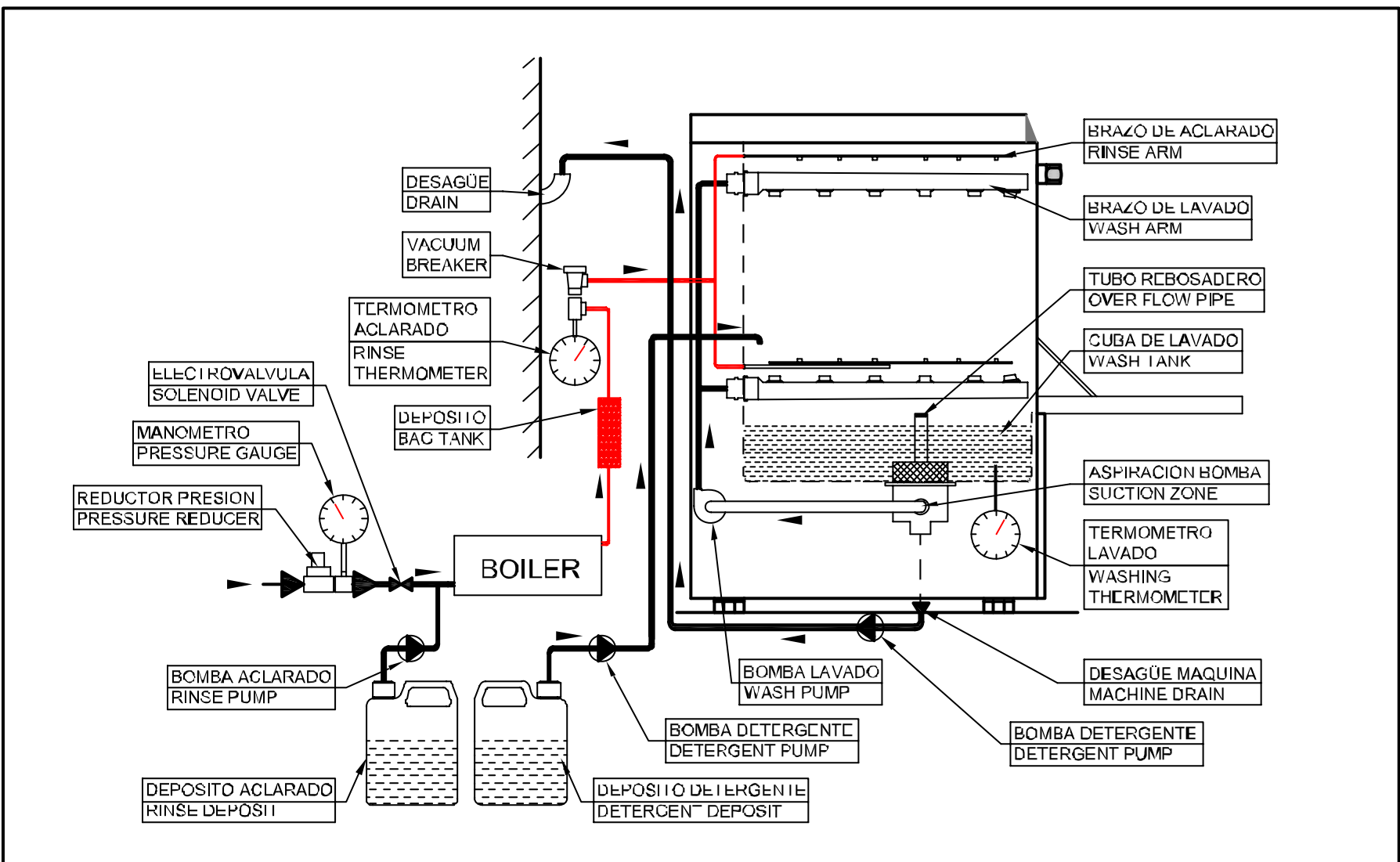



Insinger Machine Company
6245 State Road
Philadelphia, PA 19135-2996

800.344.4802

Fax 215.624.6966
www.insingermachine.com