



2nd Generation Multi-Fruit Juicer

Service Manual



March 2020



2nd Generation Multi-Fruit Juicer

Service Manual

Copyright © John Bean Technologies Corporation 2020

JBT Corporation
400 Fairway Avenue
Lakeland, FL 33801
(863) 683-5411

Manual No. FNS-0014-060-EN



Table of Contents

Important Safety Information	4
Specifications	6
General Information	7
Juicer Screen Descriptions	9
Maintenance	22
Troubleshooting	28
Rebuilding	31
Illustrated Parts List	45
Electrical Drawings and Procedures	79



Important Safety Information

You can help prevent personal injury and/or property damage.

**Please read this manual carefully before operating the Multi-Fruit Juicer.
DO NOT attempt any operation until you understand exactly how the machine functions.**

If uncertainty remains after studying this manual, **please contact John Bean Technologies Corporation.**

We're here to help. With proper handling, the JBT Multi-Fruit Juicer will provide safe, efficient and convenient service for years to come.

	North America JBT Corporation 400 Fairway Ave Lakeland, FL 33801 USA Phone: +1 863 683 5411 Fax: +1 863 680 3672	Europe JBT Corporation, S.L. Julián Camarillo 26, 4º 28037 Madrid Spain Phone: +34 91 304 00 45 Fax: +34 91 327 50 03	South Africa JBT (Pty) Ltd. Koper Street Brackenfell Cape Town, South Africa 7560 Phone: +27 21 982 1130 Fax: +27 21 982 1136
	Brazil JBT Máquinas e Equipamentos Industriais Ltda. Av. Eng. Camilo Dinucci 4605 14808-900 Araraquara São Paulo Brazil Phone: +55 16 3301 2000 Fax: +55 16 3332 0565	Latin America JBT Corporation Carr. Mty-Salttillo Km 7—Bodega 4 Colonia Las Mitras Santa Catarina, NL Mexico 66350 Phone: +52 81 81 23 70 55 Fax: +52 81 81 23 70 54	Asia / Pacific JBT (Shanghai) Co. Ltd. Room 3002-3003 Haitong Security Building No. 689 Guangdong Road Shanghai 200001, China Phone: +86 21 6341 1616 Fax: +86 21 6341 0708

www.jbtcorporation.com

Revision History

Manual Code	Rev.	Date	Change History
FNS-0014-060	A	06/14/19	Initial release
FNS-0014-060	B	01/10/19	Updates
FNS-0014-060	C	03/19/20	Updates

Safety Labels

The safety labels shown below appear on the Juice Extractor. Safety labels provide essential instructions on how to avoid possible hazards.

Please, for your safety: FOLLOW THOSE INSTRUCTIONS AT ALL TIMES.

Should the Juicer safety labels become damaged or unreadable, contact JBT Corporation for replacement labels.



Safety Instructions

Carefully review the following safety instructions.

Make them a habit when using the JBT Corporation Multi-Fruit Juicer.

1. If Juicer continues to run when any access cover is open, the interlock switch is defective. **Turn Juicer off immediately.** Call for service.
2. Prevent unauthorized access to Juicer by locking all covers with supplied key.
3. Prevent unauthorized operation of Juicer by placing electrical plug inside cart door.
4. **NEVER** attempt to make any safety device inoperative.
5. **NEVER** operate or perform maintenance or repair work on the Juicer when taking any kind of drug or sedative, when under the influence of alcohol, or when fatigued.
6. **ALWAYS** check adjustment of all nuts, bolts, and screws after installation, repair, or periodic maintenance.
7. **NEVER** attempt to operate or transport machine if the caster wheels are damaged, do not roll freely, or if front and rear brakes do not lock.



Specifications

Technical Specifications

Fruit size: 2 1/2" to 3 3/4" diameter (6.5 cm to 9.5 cm)	
Oranges — FL:	125 to 50 count
Oranges — CA:	138 to 48 count
Grapefruit — FL:	56 to 48 count
Hopper capacity:	80 lb. (2 cartons) (36 kg)
Reservoir capacity:	3.5 gal. (1 carton) (13.2 liters)
Waste container capacity:	40 lb. of peel (2 cartons) (18 kg)
Three Speeds:	25 fruit/minute, 29 fruit/minute, 33 fruit/minute

Electrical Specifications

115V, 60 Hz Single Phase 15 AMP Service on a dedicated circuit
 10 GA. wire — up to 200 ft. from main breaker panel
 or
 220 VAC, 50 Hz / 60Hz Single Phase 16 AMP Service
 10 GA. wire — up to 200 ft. from main breaker panel

Shipping Specifications

Height:	65.4"	(166 cm)
Width:	26"	(65 cm)
Depth:	35"	(89 cm)
Weight:	711 lbs	(323 kg)

Patents

U.S. Patents - #4905586 and #4922814
 and Patents Pending

General Information

The JBT Corporation Juicer is designed to provide years of dependable service. It uses a unique patented design to extract every available amount of juice from the fruit with the least amount of peel oil. The peel is completely separated from the juice and juice sacs before being compressed and strained.

The machine will juice all types of citrus — oranges, grapefruit, lemons, limes, tangerines, etc. — without changing or adjusting parts. In fact, different varieties and sizes of fruit can be juiced to create various fruit juice blends.

Clean-up is simple, requiring disassembly of only five parts. All waste material — peel, membranes, and seeds — is collected in a disposable garbage bag for easy removal and disposal.

The Juice Extractor is solidly built using heavy duty components in all assemblies, including the drive. It is simple to operate and uses a minimal number of parts.

ALWAYS follow cleaning and maintenance schedules in this manual to prevent equipment damage and maintain juicer performance.

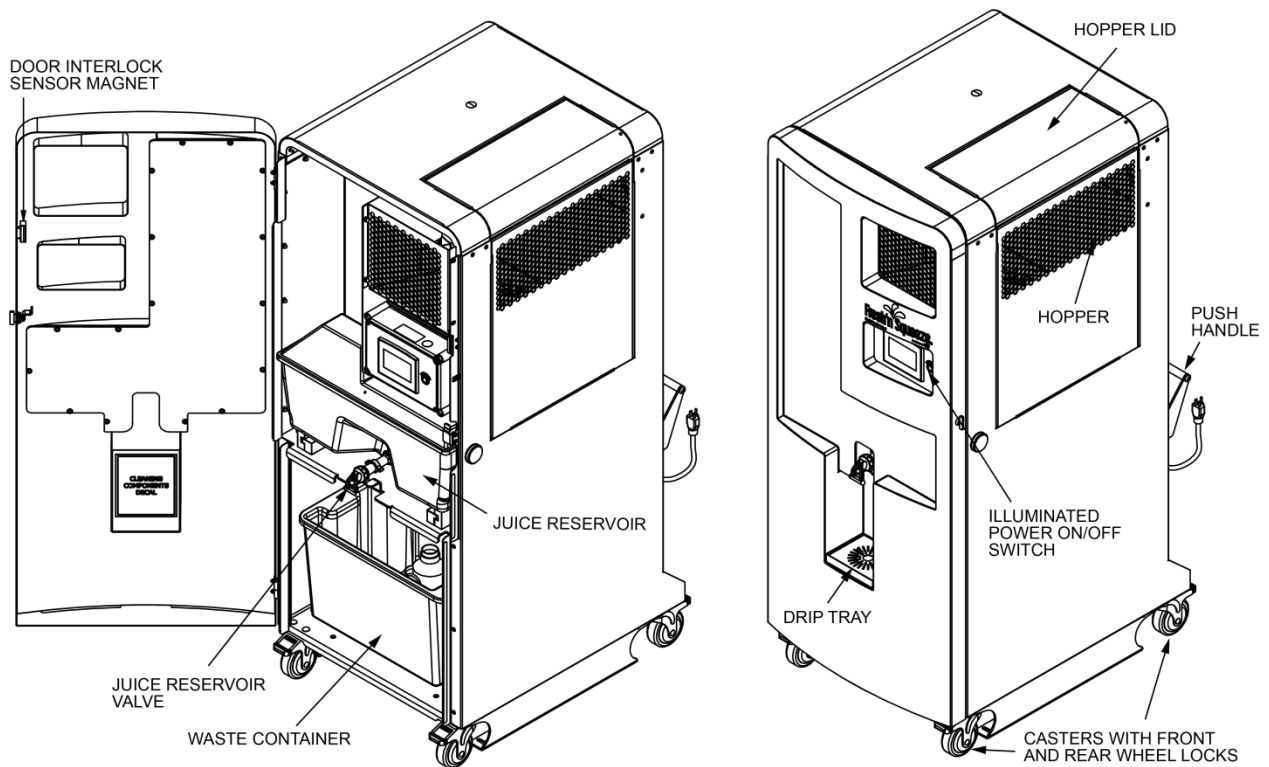

Figure 1. 2nd Generation Multi-Fruit Juicer

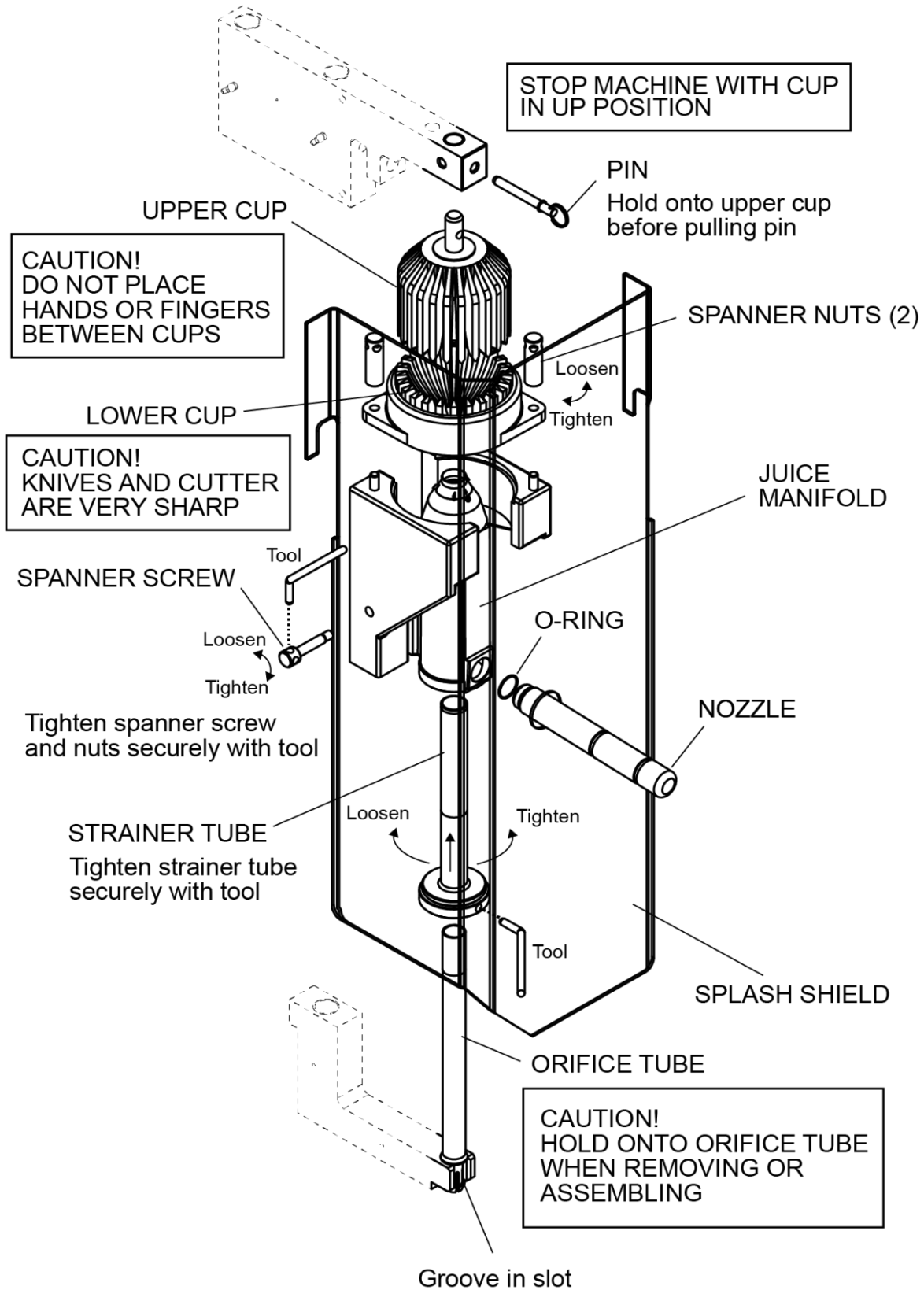
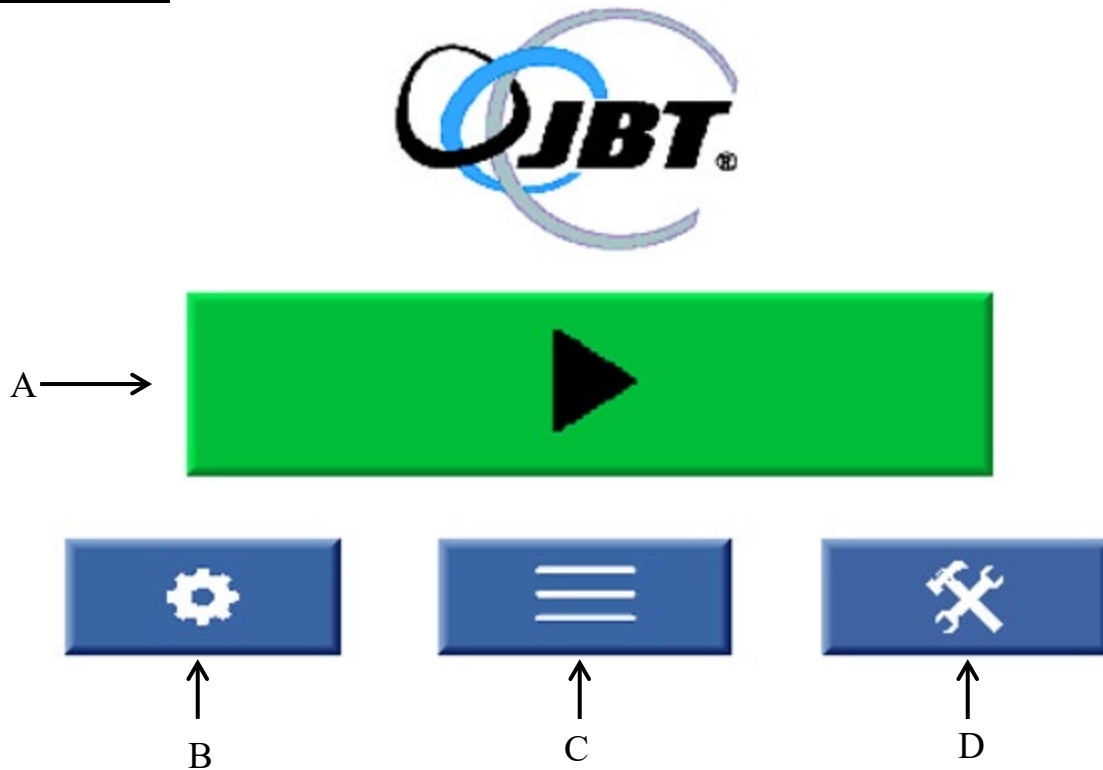

Figure 2. Juicing Components Assembly

Juicer Screen Descriptions

Standard Start Screen



Self-Service Start Screen

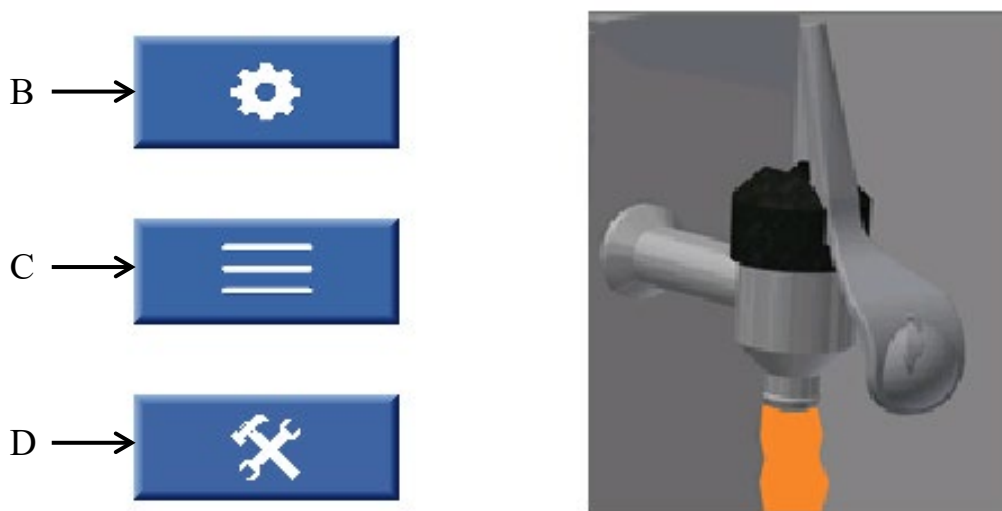

- A. Start Button** – Starts juicing
- B. Go to Settings** – Options to change the juicing speed and the animation shown while juicing.
- C. Go to Status** – View various information about the unit.
- D. Go to Service** – Various settings for the juicer (service personnel only).
Access requires a password which is simply “1”.

Service 1

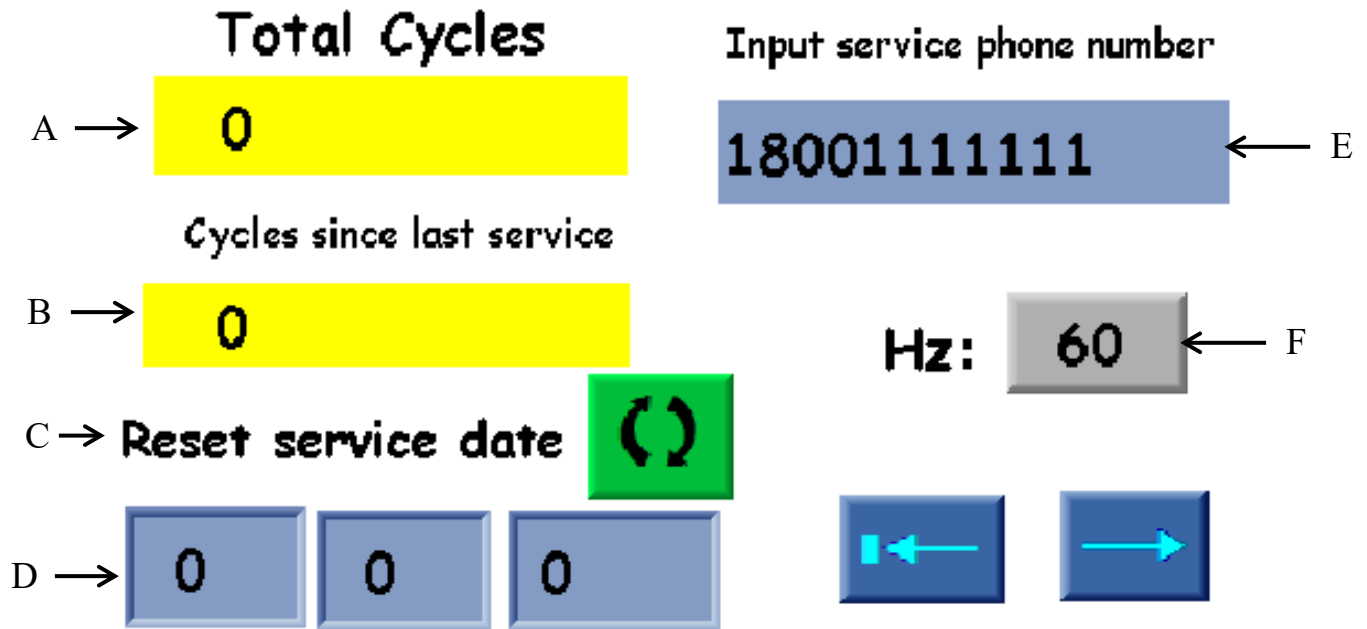

- A. Total Cycles** – Indicates the total number of cycles the juicer has run. This is value can be changed by clicking on it. This is only meant for cases where electrical boxes are being replaced so that the total juicers cycles will not be lost.
- B. Cycles since last service** – Indicates how many cycles have run since the last time the juicer was serviced.
- C. Reset Service Date** – The button to the right of this will reset the service date shown below as well as on the status screen.
- D. Last Service Date** – This shows what the date of the last service was for the juicer. The format for this date is: Month Day Year.
- E. Support Phone Number** – Phone number for the service company for the juicer. To change the number, simply click on the number itself and a keyboard will appear. If desired, dashes and symbols can be added by clicking the down arrow on the top left twice, the dash is next to the enter button. Click the up arrow in the top left to return to the numbers. This phone number appears for general users on the Status page and Safety Fault screen.
- F. Constant speed setting** – Setting for testing the juicer at a constant speed either slower or faster than normal operation. To use this feature the juicer must be on the normal speed setting (top option on the settings screen). Once on this setting, the juicer will operate at whatever frequency is specified here between 15 and 90 Hz. For example, with this feature the juicer can be set to run at 15 Hz to see if parts are interfering with each other. This is programed to default to 60 Hz whenever the juicer is powered off so as not to affect customer operation.

Service 2

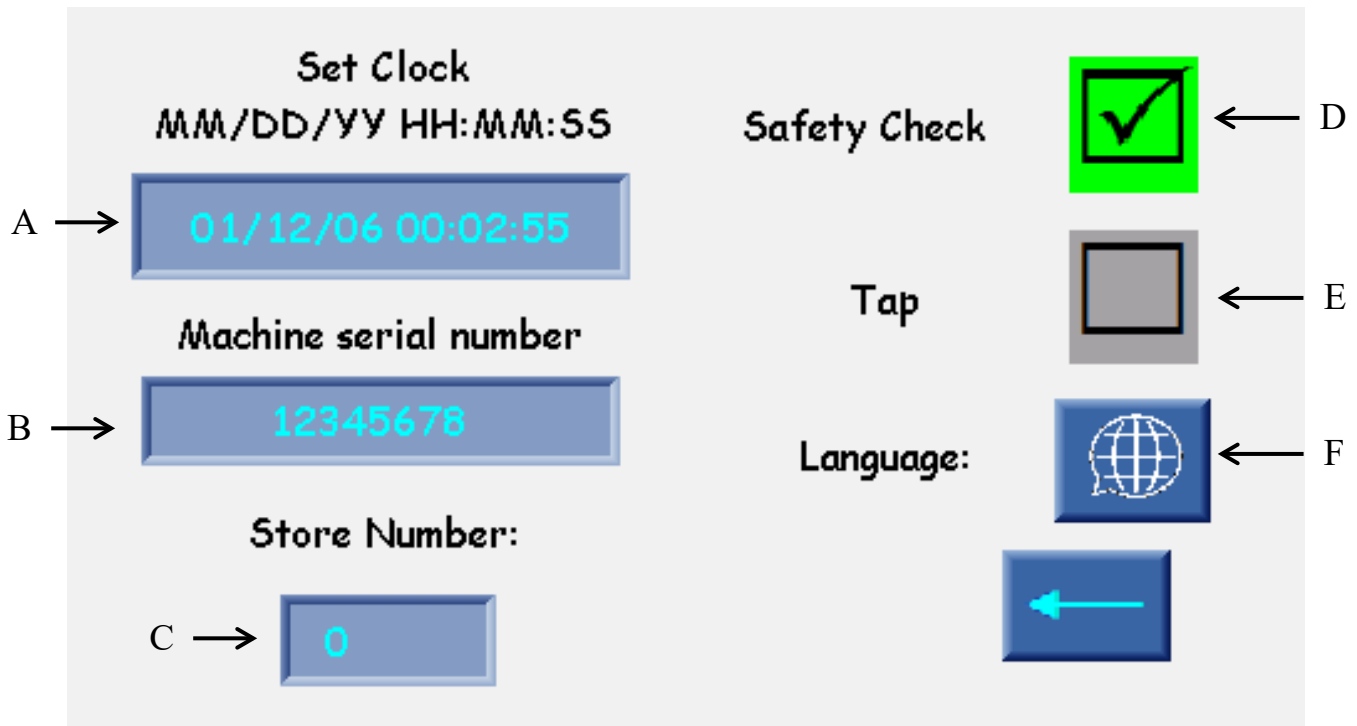

- A. Clock** – To change the date and clock, click on the numbers. Date and time format are show above. Time is based on 24 hour format
- B. Machine number** – Click the numbers to enter the juicer's serial number. The serial number can be found on the plate on the back of the juicer towards the bottom. The number entered here is also displayed on the status page for general users to view.
- C. Store number** – Optional feature for entering an identification number for the facility where the juicer is located. Currently not used elsewhere in the software.
- D. Safety Check** – Only viable on certain juicers. This provides a warning (shown later) if a safety sensor has failed or is unplugged.
 - a. Turning this on for juicers that do not support this feature (certain juicers with serial number starting with 83 and 93) will cause the safety circuit fault to always be on, regardless if the safeties work or not. Refer to Safety Circuit Fault screen to turn off.
- E. Tap** – Changes how the juicer is operated. When activated, the juicer will run when the tap handle is depressed, there is no longer a start button. Be aware that this feature requires several physical alterations to the juicer including removal of the tank, a new front door, tap housing, new safety sensor assembly, and modified juice manifold.
- F. Language** – Selection page to determine what language all the text is displayed in, available languages are shown next.



Languages

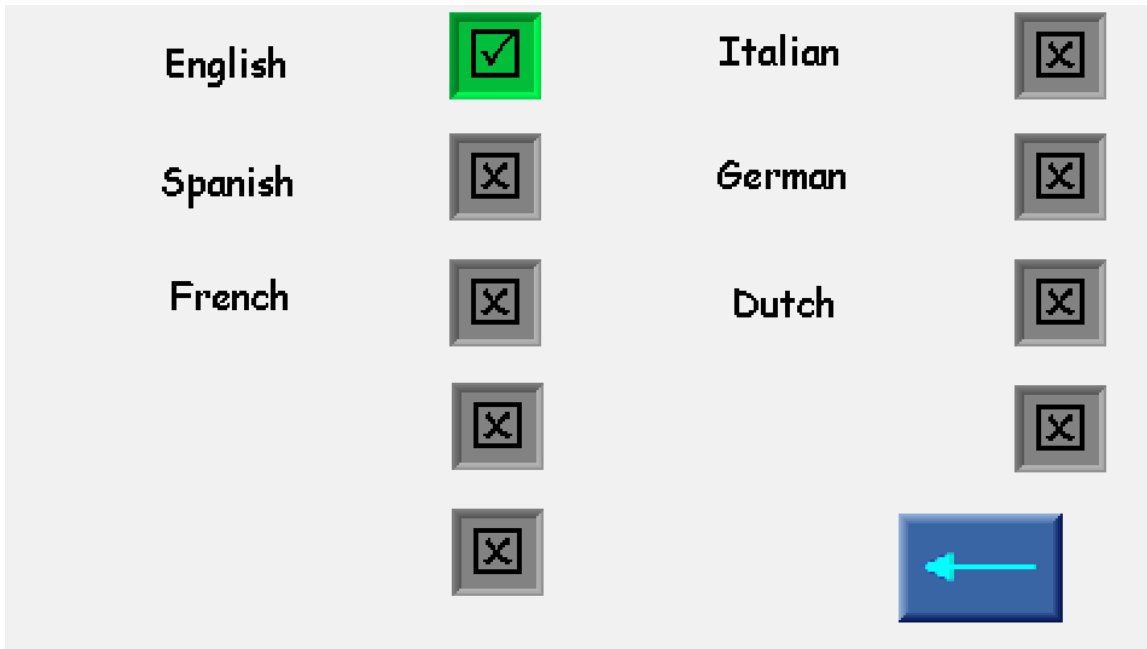

Selection for the language of all of the text found in the software. If language is changed accidentally this page can be reached from the start screen or tap screen by:

1. Enter service page (gear icon) – again password is "1".
2. Click the next button (right arrow) found on the bottom right.
3. Click the globe text bubble on the right.

There are currently six available languages as shown here.

Processing Screens

These screens appear when the juicer is actively running.

There are two animations available which can be chosen on the settings page.

Processing...

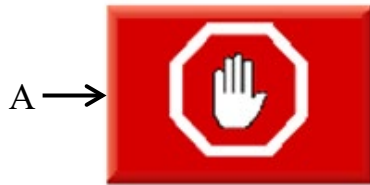

Processing...



A. Stop Button – Juicer will continue to run until it reaches the point when the cups are farthest apart.

- **NOTE 1** - In tap mode, the tap handle must be held down for this to function. Once the juicer has stopped, then the handle can be released.
- **NOTE 2** – if the positioning sensor is not functioning this stop button will cause the juicer to stop immediately.



Front Door Open

Attention!

Front Door Open

**Close door before
Restarting**

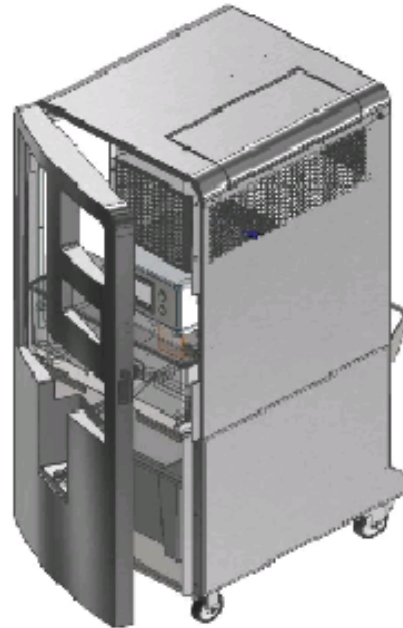

This screen indicates that the front door is not properly closed. The juicer will not run until the door is fully closed

If this screen is appearing when the hopper door is open it indicates that the cables on the back of the electrical panel are reversed. These are the two smaller plugs next to each other with two cables entering the back of each plug. Switch these two plugs. Open the front door and ensure the correct screen appears.

If this screen is always on it indicates that the front door safety sensor has malfunctioned. Verify by swapping the safety cables on the back of the electrical panel. The error message should switch to the hopper door and still remain on constantly. The cable assembly will need to be replaced, make sure the cables are connected in their correct location if they had been swapped for testing.

Hopper Door Open

Attention!

Hopper door open

**Close door before
restarting**

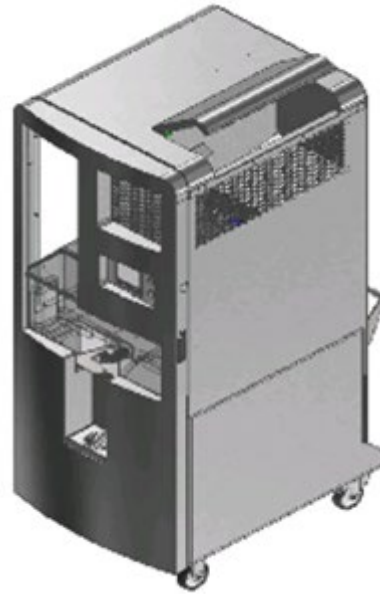

This screen indicates that the hopper door or fruit loading door on top is open. The juicer will not run while this door is open

If this screen is appearing when the front door is open it indicates that the cables on the back of the electrical panel are reversed. These are the two smaller plugs next two each other with two cables entering the back of each plug. Switch these two plugs. Open the hopper door and ensure the correct screen appears.

If this screen is always on then it indicates that the hopper door safety sensor has malfunctioned. Verify by swapping the safety cables on the back of the electrical panel. The error message should switch to the front door and still remain on constantly. The cable assembly will need to be replaced, make sure the cables are connected in their correct location if they had been swapped for testing.



Settings Screen

A → **Speed Setting**



Display Setting ← B

Filling Glass



Dancing Orange



- A. Speed setting** - The juicer can run at 25, 29, or 33 fruit per minute. Be aware that some harder or larger fruit may not process at the higher speeds, attempting to do so could lead the juicer to stall repeatedly.
- B. Display setting** – Controls the animation seen while the juicer is running (the processing screens shown previously).

Status Screen

This mirrors a lot of the information on the service screen but here it cannot be edited.

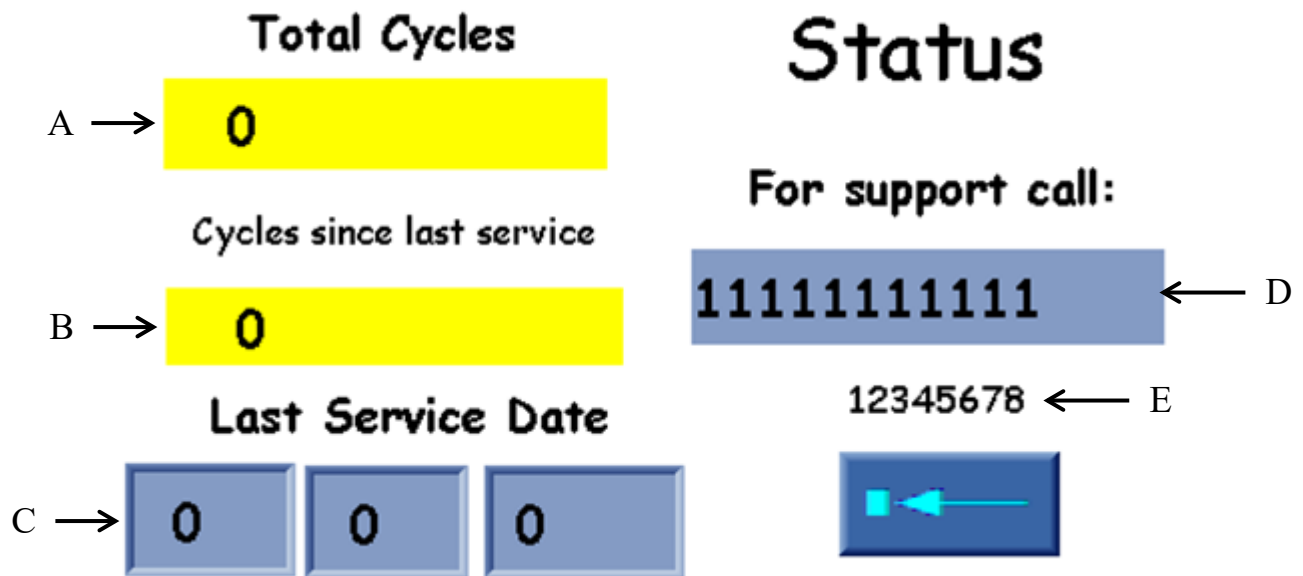

- A. **Total Cycles** – Indicates the total number of cycles the juicer has run.
- B. **Cycles since last service** – Shows how many cycles have run since the last time the juicer was serviced.
- C. **Last Service Date** – Date of the last service was for the juicer.
Format for this date is: Month Day Year.
- D. **Support Phone Number** – Phone number for the service company for the juicer.
- E. **Juicer serial number** – Serial number for the juicer.



Juice Tank Full

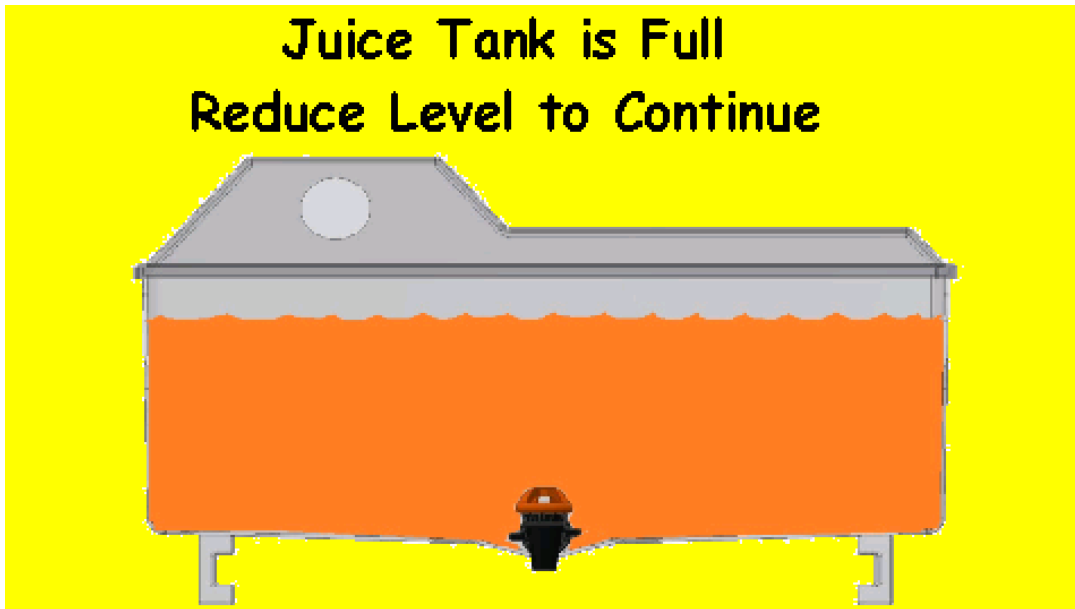

When this screen appears it means that the juice tank is full and the juicer has stopped. The juicer will not run again until juice is removed from the tank.

Motor Fault

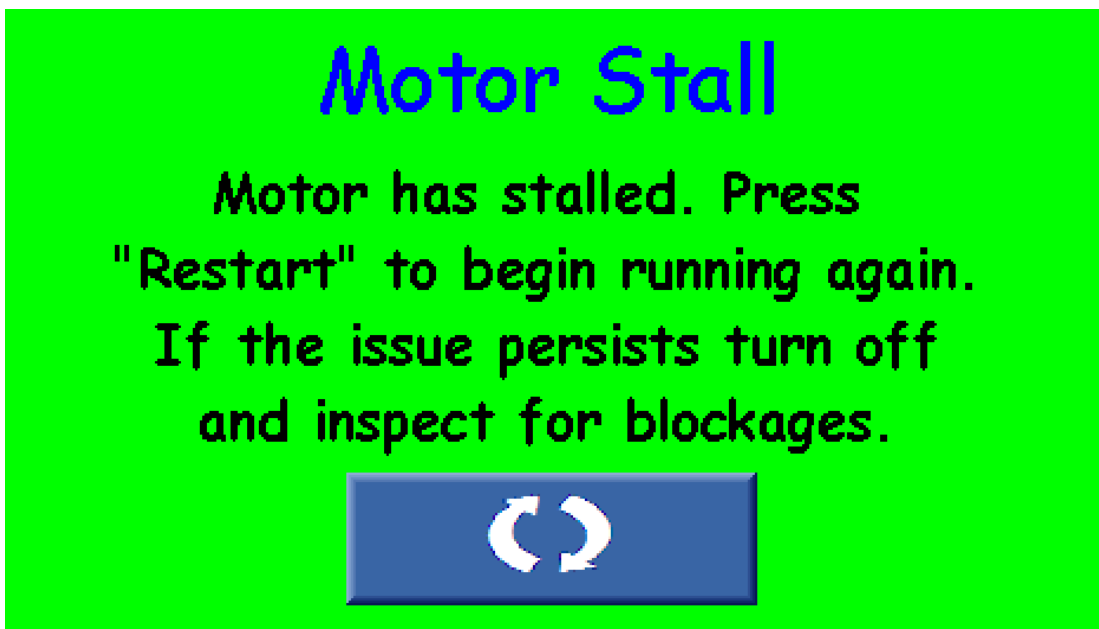

If this screen appears it means that motor has stopped. This is usually caused by a blockage, large fruit, hard fruit, frozen fruit, or something else. Press the (↺) button for the juicer to restart. If the error continues, the blockage will need to be removed manually. *Always power off the juicer before attempting to clear any blockage.

In some rare cases the juicer may need to be manually moved in order to clear the blockage.

If this screen appears often, it may mean the juicer is being run at too high of a speed for the fruit being used. Try using one of the slower speeds to prevent this.

Position Sensor Error



This error message occurs because the juicer is operating, but the position sensor (also referred to as TDC or Top Dead Center sensor) has not been detected. The juicer is still capable of running, but several features will be disabled. These features include:

1. The speed settings will not function properly, this could lead to the juicer stalling often. Normal operation at the two faster speeds the juicer will slow while pressing the fruit to achieve more power. If the position sensor is not detected, the juicer will not slow down and instead run constantly at the faster speed. This will likely lead the juicer to stall more because it does not have the power to properly press the fruit.
2. Pressing the stop button now will cause the juicer to stop immediately instead of running until the cups are farthest apart.
3. Cycle counts will no longer be tracked.

Unplug the juicer and open the back panel, make sure that the safety sensor is connected.

If the sensor seems to work intermittently, check the position and mounting bracket used to hold the position sensor. The bracket is not symmetrical and should be mounted so that the sensor holes are near the back of the juicer and away from the juicing components. Also, the sensor itself has slots so when mounted, the sensor should be pushed towards the back of the juicer as much as possible.

Improper positioning can cause the juicer to double count cycles. If work is done on this sensor, be sure to check the cycle count. Run the juicer for five cycles and recheck the cycle count.



Safety Circuit Fault

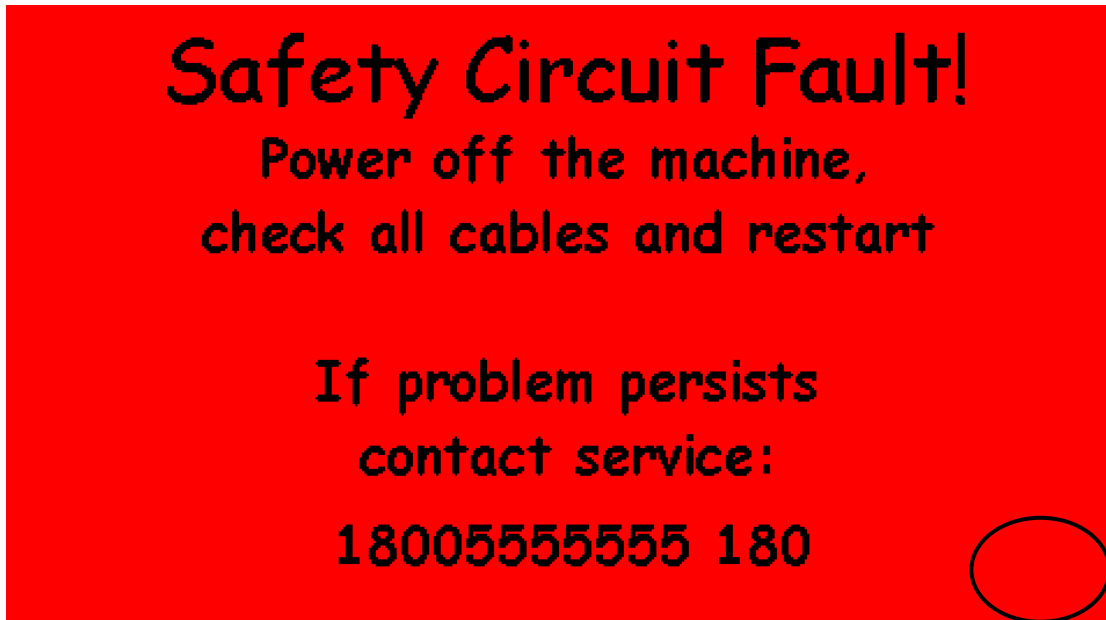

When this message occurs it indicates there is a problem with one of the safety sensors. The juicer will not run until the problem has been fixed.

It is possible one of the cables is not connected. Turn off the juicer and verify that all cables are connected properly.

If the cables are connected, then it is possible a safety sensor has failed. Follow the procedure for checking safety circuits in the “Electrical Drawings and Procedures” section of this manual to determine which sensor is faulty.

This screen can be disabled. There is a hidden button in the bottom right corner (A), this pulls up the password which is the same as for the service screen. Once on the service screen, go to the second service screen and turn off the safety check.

NOTE: This will not fix a problem, if a cable is unplugged or safety has failed, the juicer will still not run.

Battery Warning



If this error message occurs, it indicates that the battery in the touch screen is running low. The juicers are setup so they should run if the battery dies. However, in some cases the software will be lost and the juicer will not operate. It is best to replace the battery as soon as possible.

Refer to the battery replacement procedure in the “Electrical Drawings and Procedures” section of this manual.

If the battery was just replaced and the screen still appears, ensure the correct battery was used, the battery is firmly seated, and there are no smudges or fingerprints on the battery when it is inserted.

Maintenance

Before performing any maintenance,

DISCONNECT ELECTRICAL PLUG.



LOCK FRONT AND REAR CASTER WHEELS.

After every juice run:

1. Check cutter and knives for sharpness.

Refer to **Figure 6** to determine condition of cutter.

If dull, sharpen with a whetstone provided.

Refer to **Figure 6** to sharpen cutter.

If cutter is severely damaged or rolled over, replace cutter.

a. Cutter removal:

Disassemble juicing components (Figure 2). Loosen set screw under front knife (make sure screw is backed out far enough to clear cutter). Cutter should lift out, if not, tap the cutter lightly from inside the juice manifold with a 1-1/4" diameter rod (hammer handle).

CAUTION: CUTTER AND KNIVES ARE SHARP.

Install red protective cap provided onto cutter. After red protective cap is installed, remove cutter. Handle cutter with care to avoid direct contact with sharp edge.

b. Cutter installation:

Align arrows on cutter and juice manifold to seat cutter. Make sure cutter is fully seated. Tighten set screw. (**DO NOT** over-tighten.)

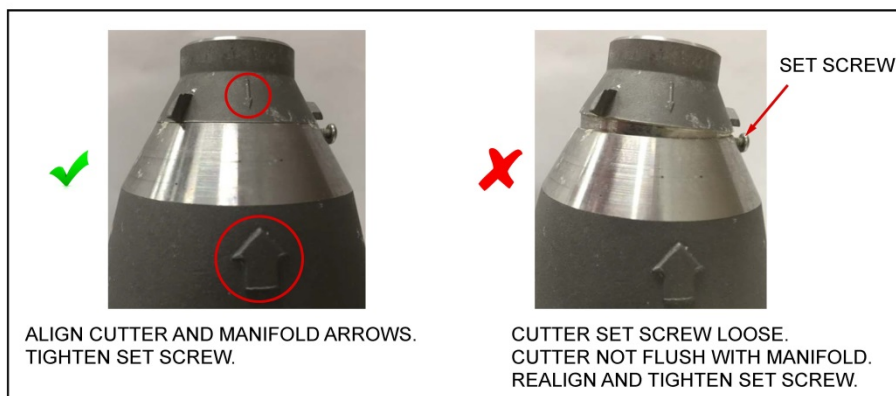

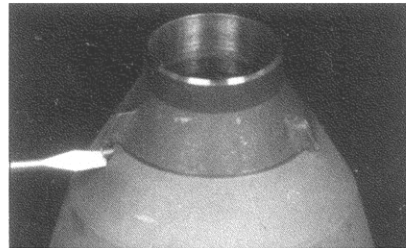

INSTALLATION OF
GOOD CUTTER

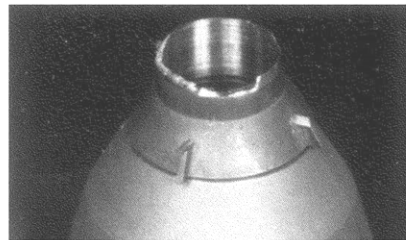

BAD CUTTER
REPLACE CUTTER

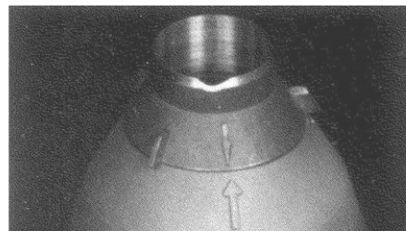

CUTTER THAT
CAN BE SHARPENED



SHARPENING CUTTER
WITH WHETSTONE



SHARPENING KNIFE
WITH WHETSTONE

Figure 6. Sharpening Cutter



Maintenance (continued)

- 2. Check orifice tube for damage.
Refer to Figure 7.**

Replace tube when:

- a. Chunks are missing from top end.
- b. Score marks 1/32" or deeper appear along the length of the tube.

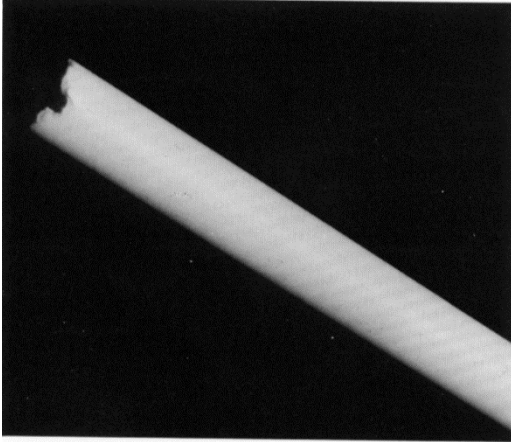

Figure 7. Severely Damaged Orifice Tube

- 3. Check for loose or missing nuts and bolts.**
 - a. Tighten or replace nuts and bolts as necessary.
 - b. **DO NOT** exceed torque ranges specified.
 - c. **ALWAYS** use JBT Corporation recommended spare parts.

ORIFICE TUBE INSTALLATION



CORRECT ✓

GROOVE OF ORIFICE TUBE
INSTALLED IN LOWER ARM SLOT

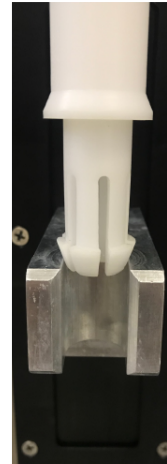

INCORRECT ✗

ORIFICE TUBE INSTALLED
ON TOP OF LOWER ARM SLOT

RESULTS OF IMPROPER ORIFICE TUBE INSTALLATION



DAMAGED ORIFICE TUBE
AND CUTTER



ORIFICE TUBE BROKEN OFF
INSIDE UPPER CUP



ORIFICE TUBE DOES NOT
CLEAN STRAINER TUBE
(EFFECTS JUICE YIELD
AND QUALITY)

Figure 8. Proper Orifice Tube Installation



Periodic Inspection

Perform the following steps every week.

1. Test all access cover interlock switches.

Juicer should stop automatically when any access cover is opened. Individually open and close the front door and hopper access door. If juicer continues to run when front door or hopper access is opened, the interlock switch is defective.

Stop the juicer and replace the defective interlock switch immediately.

See Troubleshooting Section.

2. Inspect casters for damage or wear.

Caster must roll freely and front and rear brakes must lock.

3. Check all fasteners for tightness.

Check especially on the Sprockets, Crank Arms, Fruit Lift and Hopper.

4. Check chain for tightness.

Refer to Figure 9.

Chain should have 1/4 inch maximum slack on top side. To adjust, loosen the tensioning bolt located on the chain tensioner until 1/4 inch of slack is measured.

CAUTION: DO NOT OVER TIGHTEN CHAIN.

5. Check chain and sprockets for rust.

Lubricate chain and sprockets should rust appear. JBT Select FG Spray (Non-Drip), p/n [575054](#), is recommended.

6. Lubricate grease fittings with JBT Select 2FG grease, p/n 575066.

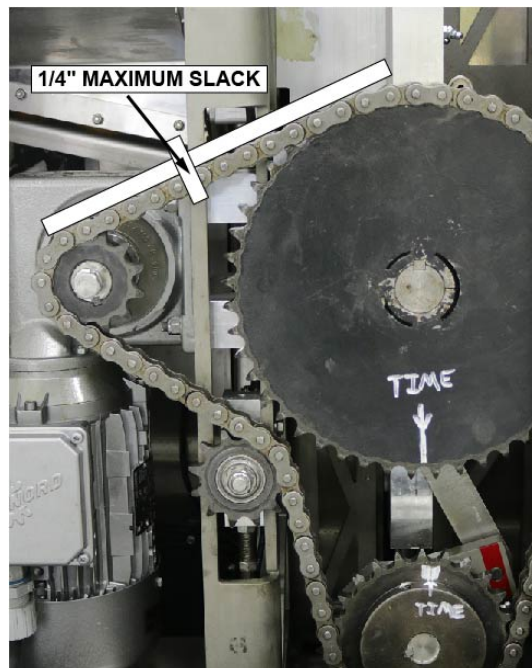

Figure 9. Checking Chain Slack

7. Check gear motor.

If Juicer has been laid on its side for any reason (i.e., during shipping), or if there is any evidence of oil leak, check oil level and add oil, if necessary. **Refer To Figure 10.**

Use FUCHS FM220 GEAR OIL FG only.

8. Check hopper.

To remove hopper, fruit lift (upper cup drive) must be in down position. Remove two spanner screws using spanner wrench. Remove hopper.

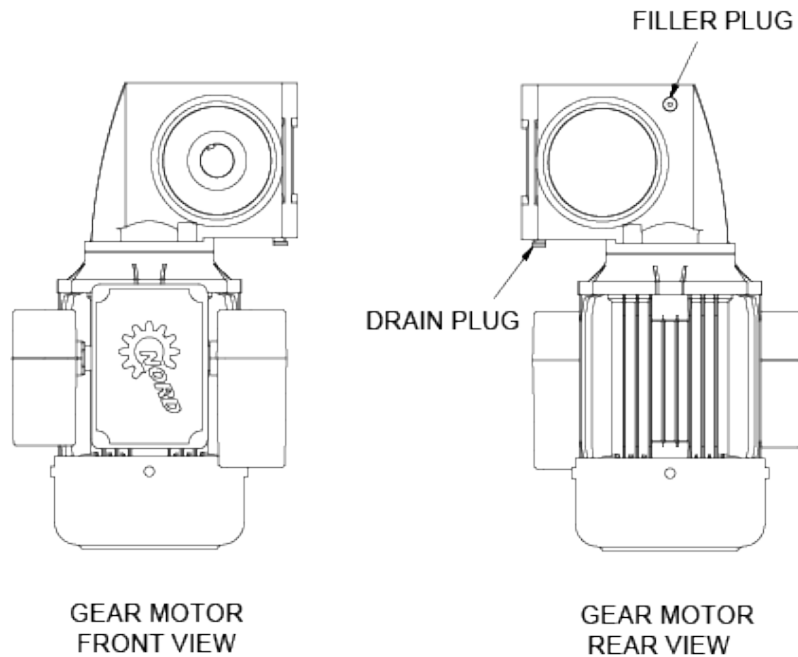

Figure 10. Gear Motor



Troubleshooting

- **Juicer will not turn on**

1. **Juicer is not plugged into electrical outlet.**
2. **Building circuit breaker or GFI has tripped (reset).**
3. **Loose wire connection.**
Check that all electrical connections are properly installed and secured.
4. **On/Off power switch is disconnected**
 - a. Unplug the juicer.
 - b. With the Front door open loosen the four screws holding the electrical box closed.
 - c. On the backside of the lid insure that the two black wires (103 and 104) are connected to the On/Off switch.
 - d. If power switch is broken replace lid of electrical box or the entire box.

- **Juicer starts, but shuts off**

1. **Juicer is tripping GFCI outlet**
Certain GFCI outlets will not support the juicer. Have electrician replace with a compatible outlet.

Known compatible outlets include all models of Legrand 1597 for 15 Amp service and all models of Legrand 2097 for 20 Amp service. Others may work as well
2. **Building circuit breaker is not properly rated for 15 Amps.**
3. **Extension cord or wiring is too long.**
Shorten extension cord or use heavier gauge wire. (See Page 6 "Electrical Specifications")
4. **All covers not completely closed (including cart).**
Juicer may be flexing when squeezing fruit, causing switch to open. Make sure all latches are completely locked.
5. **The hopper and door cables are reversed.**
 - a. Unplug juicer.
 - b. Remove the hopper access panel.
 - c. Unplug the hopper and front door cables (two smaller connectors on top and farthest from access panel).
 - d. Switch the cables and plug them back in.

- **Juicer will not start**

1. **Covers are not completely closed.**
Open and close both doors, make sure the sensors are securely fastened and then ensure the doors are firmly closed.
2. **Safety sensor has failed. Refer to checking safety sensors to identify broken safety sensor and replace as necessary.**
3. **Loose wire inside electrical box**

Troubleshooting (continued)

• **Safety Circuit Fault screen will not go away**

1. **Safety sensors are not connected properly.**

- Turn off Juicer and unplug from outlet.
- Remove the hopper access panel.
- Insure that all the cables on the back of the electrical box are installed and the twist locks on the connectors are tight.

2. **A safety sensor has failed.**

- Follow procedures for checking safety circuits in the “Electrical Drawings and Procedures” section of this manual.
- If Faulty sensor is found, replace safety sensor and cable assembly.

3. **Electrical box does not support safety circuit monitoring (Only perform these steps if previous troubleshooting steps do not fix the problem, the process will disable this function on the juicer)**

- Click in the bottom right corner of the fault screen.
- Enter the password for accessing the service screen.
- Enter the second service page.
- Turn off the safety check.

NOTE: This does not fix an issue, it just disables the screen. If performed on a juicer with this feature, the juicer will not run. The issue must be fixed and the safety check needs to be turned back on.

• **Juicer runs extremely slowly**

1. **Constant speed feature has been enabled.**

- Turn juicer off and back on to correct

2. **Variable frequency drive programing has been changed**

- Refer to the procedure for re-programing the VFD in the “Electrical Drawings and Procedures” section of this manual.
- Follow procedure at the bottom for a Factory Reset
- Return to the top and follow procedure to program the drive from the beginning

3. **PLC terminal strip not firmly connected**

- Unplug the juicer
- Loosen the four screws on the front of the electrical box
- On the back side of the lid make sure the green strips connected to the PLC are fully seated

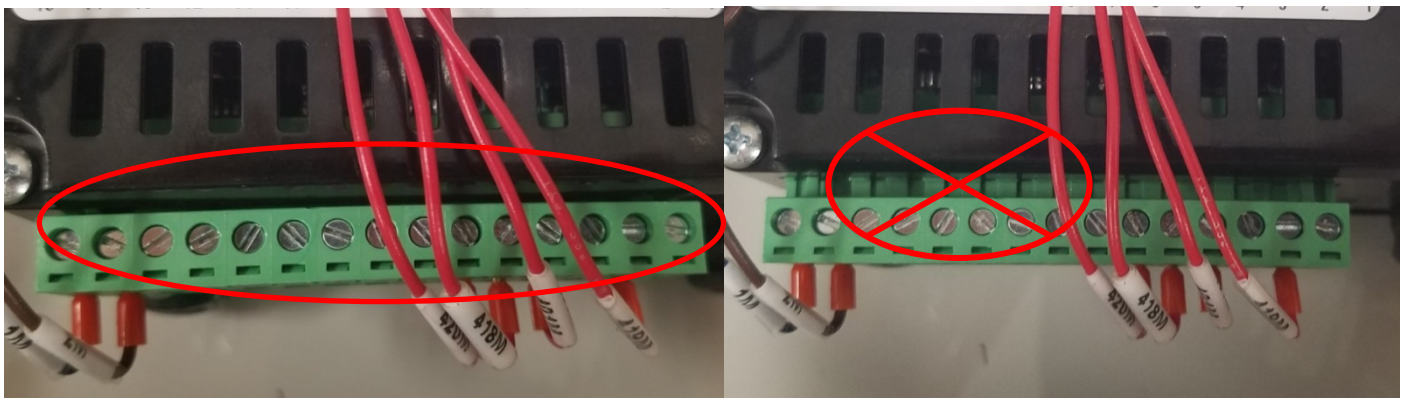



Troubleshooting (continued)

- **Juicer stalls trying to squeeze fruit**

1. **Fruit has part of stem on it.**

Turn off Juicer and unplug . Remove fruit from the Juicer and restart.

2. **Peel is too thick.**

Turn off Juicer and unplug . Remove fruit from the Juicer and restart.

3. **Juicer is operating too quickly.**

Use a lower speed setting on the settings page.

4. Turn off Juicer and unplug . Remove fruit from the Juicer and restart.

5. **Cutter is damaged.**

CAUTION: CUTTER AND KNIVES ARE SHARP.

- a. Sharpen or replace cutter as specified in Maintenance section.

- b. Install red protective cap onto cutter.

- c. After red protective cap is installed, remove cutter. Handle cutter with care to avoid contact with sharp edge.

- **Juicer runs with covers open or off**

Defective interlock switch. Replace immediately.

- **Juicer emits "squealing" sound during operation**

Spray food grade lubricant on all rotating parts.

Lubricate grease fittings on machine.

If noise continues, rod end or bearing may be defective.

- **Scraping noise coming from hopper area**

Fruit lift mechanism is dragging on hopper.

See Page 23, Item 8 under "Periodic inspection".

**NOTE: IF AN OPERATIONAL PROBLEM PERSISTS AFTER TROUBLESHOOTING,
CONTACT JBT SERVICE FOR ASSISTANCE.**

Rebuilding

It is best to replace all bearings at the same time.



Instructions for replacing all bearings, Refer to Service Videos for more details.

- 1. Remove reservoir and all juicing components.**
- 2. Remove Front Door and All Covers, Sides and Top.**
Remove hopper lid prior to removing top cover so interlock switch and cable does not need to be removed. Place the assembled hopper lid on top of the frame.

Refer to Figures 11 and 12.

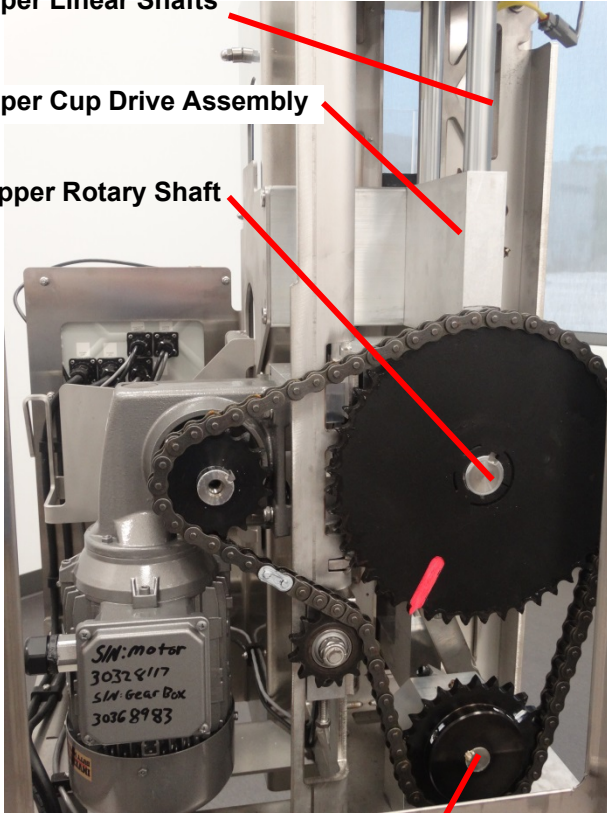

Figure 11. Juicer with All Covers Removed

Upper Linear Shafts

Upper Cup Drive Assembly

Upper Rotary Shaft



Lower Rotary Shaft

Upper Drive Crank Arm

Lower Linear Shaft

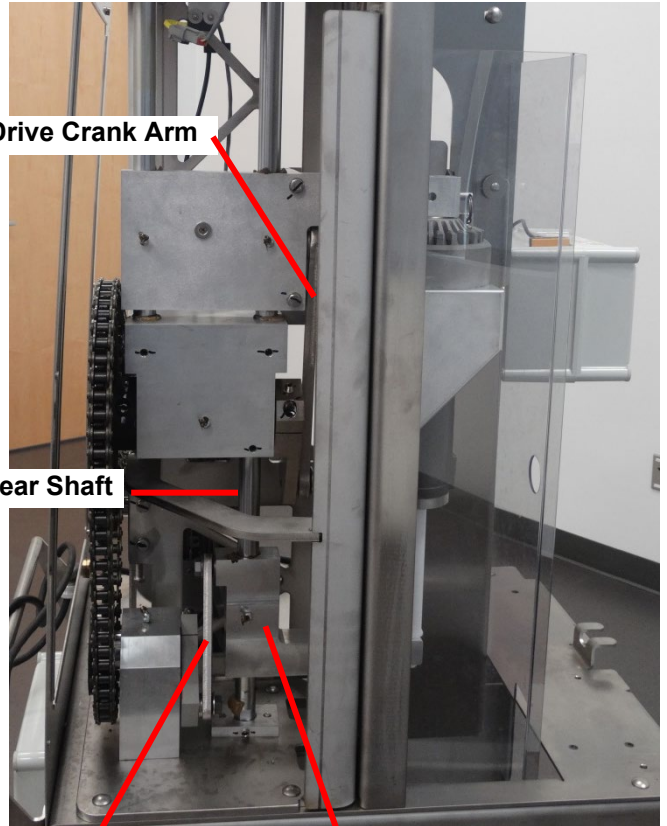

Lower Drive Crank Arm

Lower Orifice Drive Assm.

Figure 12. Back View of Juicer

Rebuilding (Continued)

3. With all side covers removed, use 3/16" and 5/16" Allen wrenches to loosen the set screw and the socket head cap screw on crank arm for upper cup drive .

(Use Motor Shaft Service Tool [06010400](#) to rotate gear motor as necessary).
Refer to Figure 13.

Repeat above steps on crank arm for lower drive.
Refer to Figure 14.

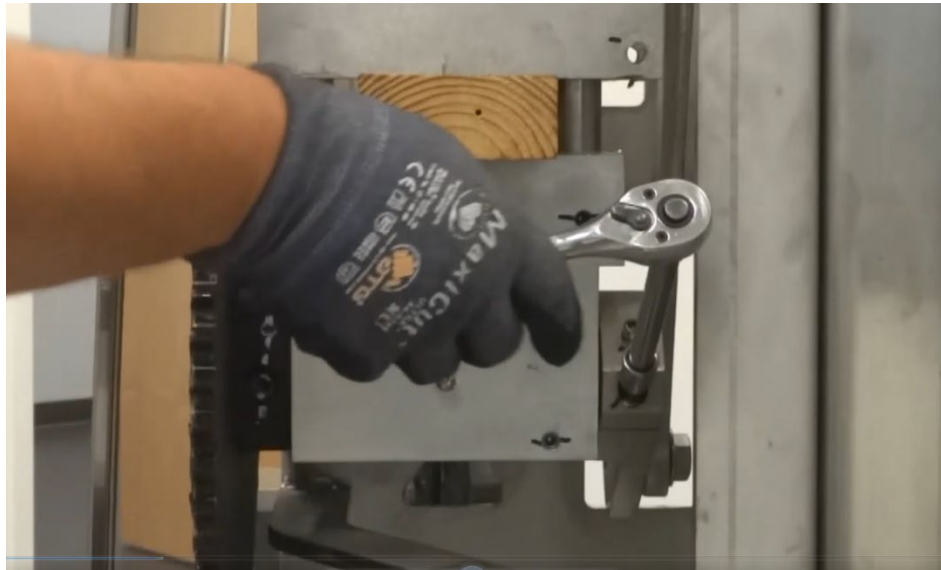

Figure 13. Using Allen Wrench to Loosen Upper Cup Crank Arm

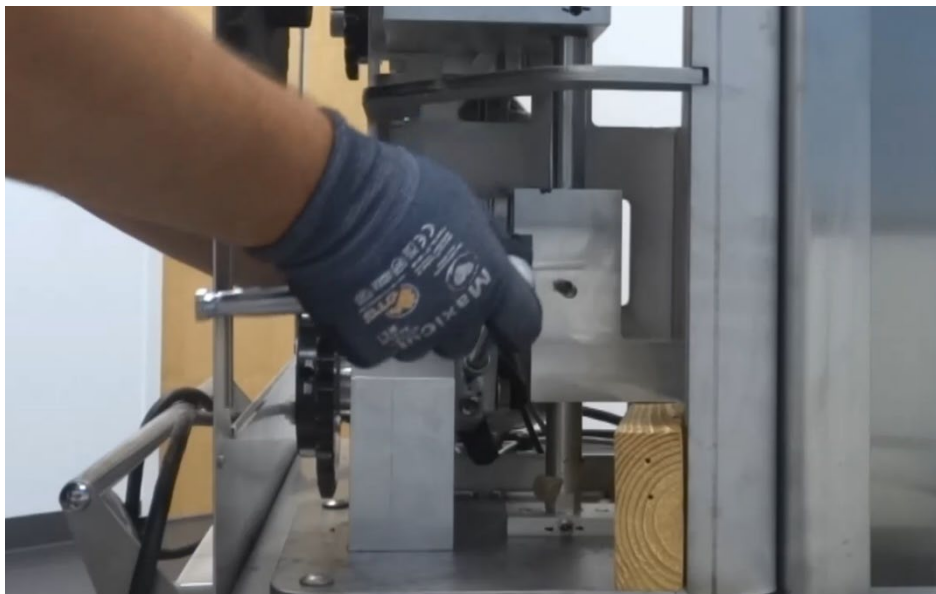

Figure 14. Loosening Lower Crank Arm

Rebuilding (Continued)

4. Remove linear shafts.

With a 3/16" Allen wrench, loosen set screws at top and bottom of all three shafts. Back screws out at least 1/4" to clear flats on shafts. If shafts are stuck, use bearing removal puller with 3/8"-16 x 2" hex head cap screw to break free shafts.

(Note: Lower Shaft will be removed downward through the waste bin area)

Refer to Figure 15.

5. Lift out upper and lower drive arms with linkages still attached.

Refer to Figure 16.

6. Disassemble linkages arms from drive and crank arms.

Note location and numbers of washers and spacers.

7. Using a similar process to step 4 Remove sprockets from shafts and then shafts from frame.

Pull or pry on large diameter upper drive sprocket, repeat for lower drive sprocket.

Refer to Figure 17.

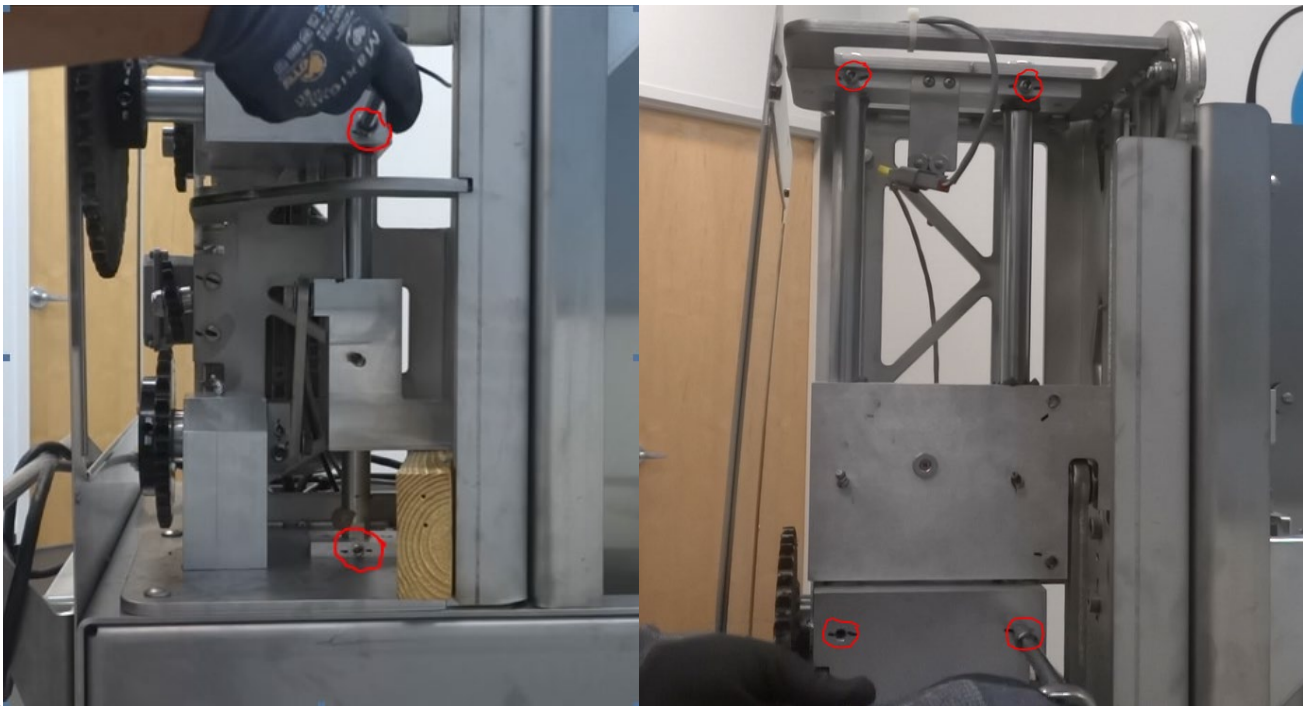

Figure 15. Removal of Linear Shafts

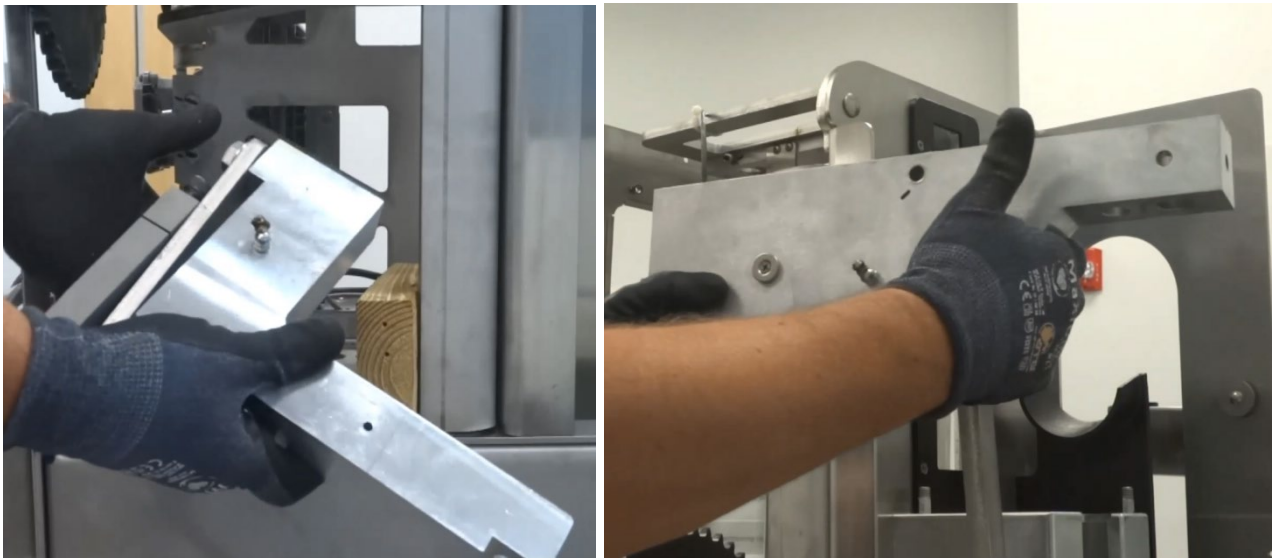

Figure 16. Removal of Upper and Lower Drive Arms with Linkages and Crank Arms

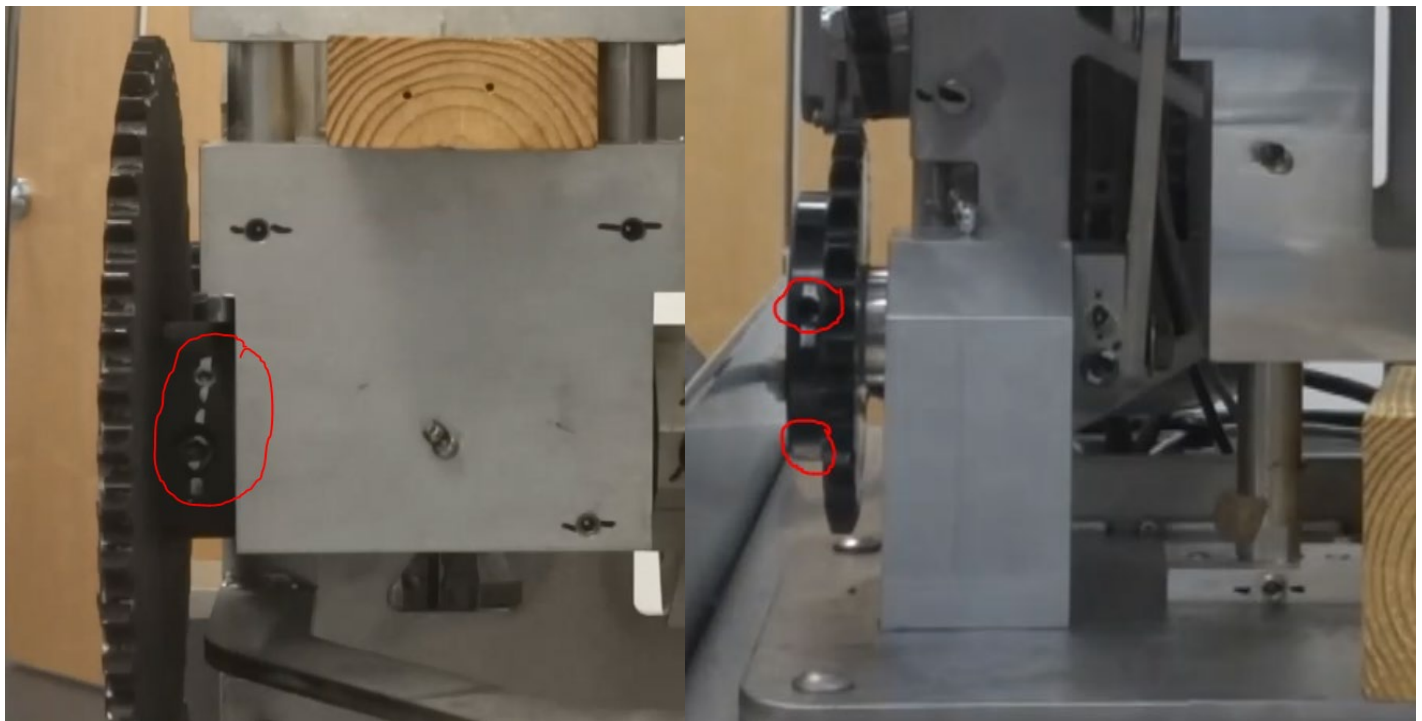

Figure 17. Loosen Set Screws and Socket Head Screws and Remove Sprockets

Rebuilding (Continued)

Some instructions below show the Generation 1 Juicer but the procedures are the same.

8. Remove sleeve bearings from upper and lower drive arms.
Refer to Figures 18 and 19.

Bearings can be pulled out using puller, 1" removal slug, and short threaded removal rod; or can be driven or pressed out using driver. New bearings can be installed by compression (**Figure 20**) by using installation pilot, installation washer and long threaded installation rod, or just use installation pilot and press bearings into place. Light coat of Teflon® grease can be used on outer diameter of bearings.

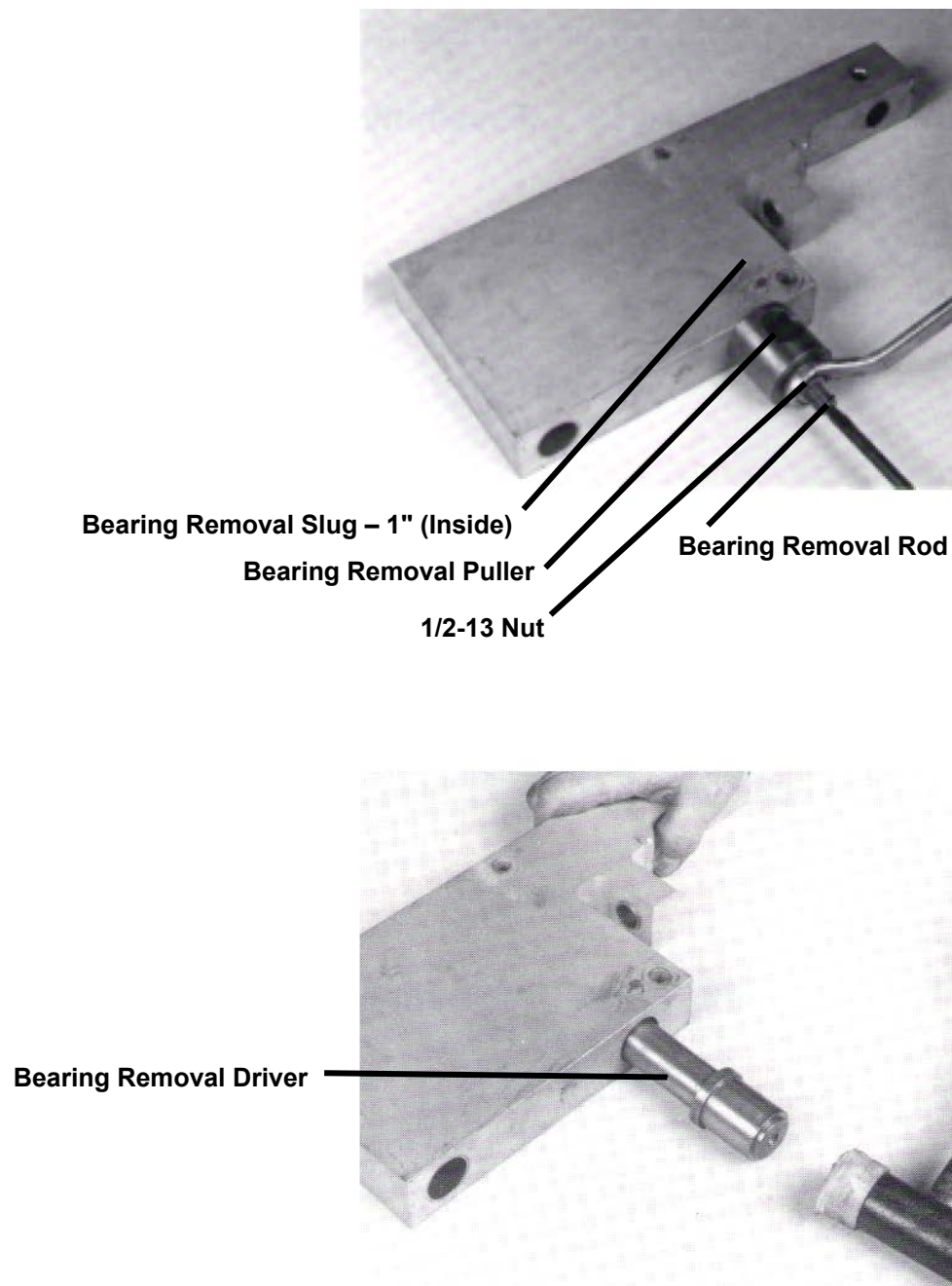

Figure 18. Removing Bearings from Upper Drive Arm

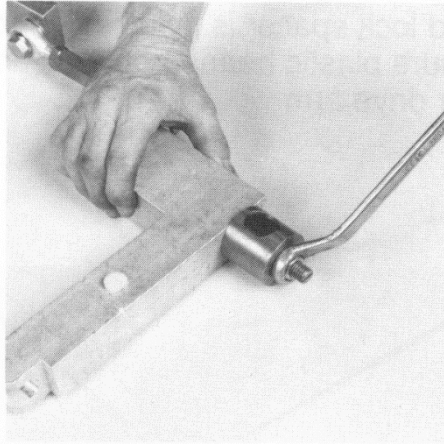

Figure 19. Removing Bearings from Lower Drive Arm

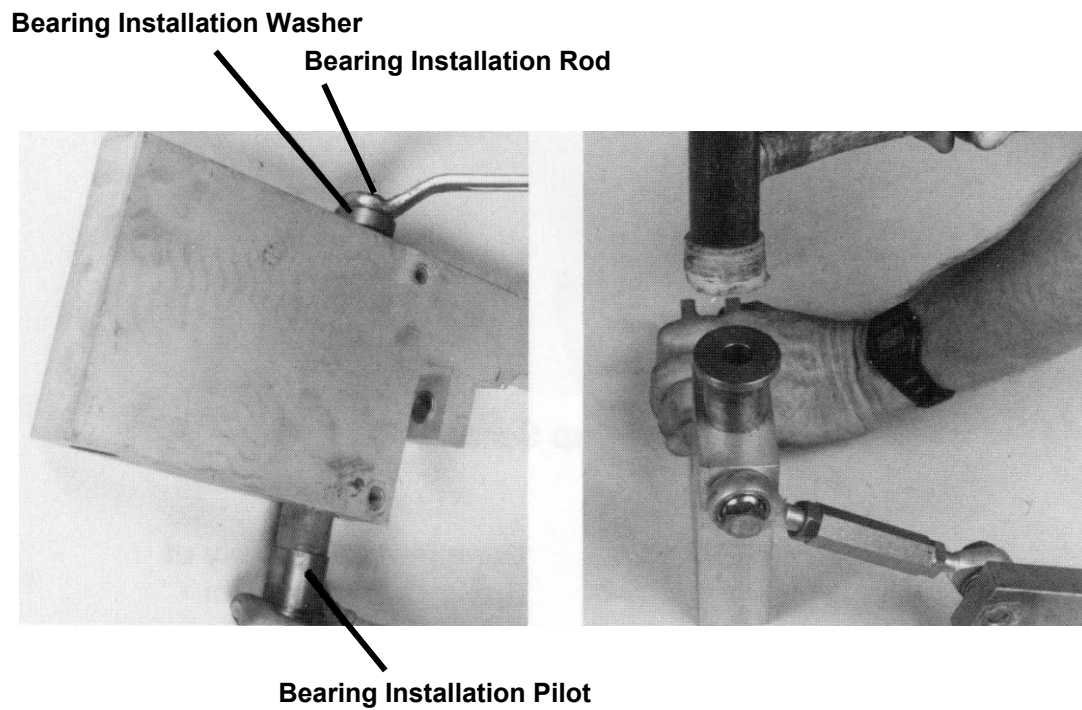

Figure 20. Installation of Bearings into Drive Arms



Rebuilding (Continued)

9. Reassemble rod end assemblies to drive arms, again making sure left hand threaded ends are on the crank arms.
Refer to Figures 21 and 22.

Use Loctite #242 on all fasteners. Tighten to torques as shown. Make sure rod end lock spacer is installed on rod end in upper drive arm. Make sure plastic bearing buttons are installed on each side of lower drive arm.

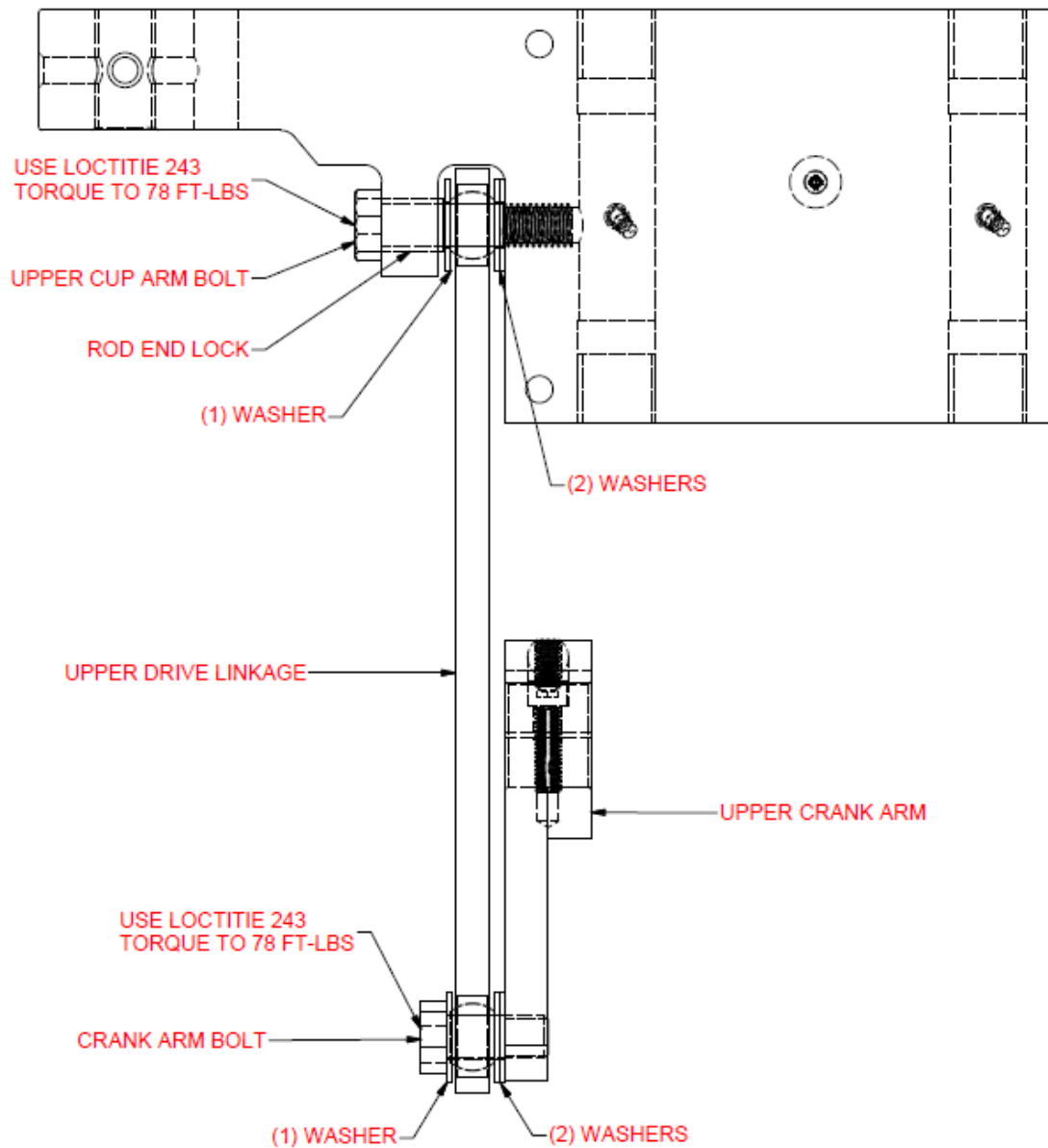

Figure 21. Completed Assembly of Upper Cup Drive Arm

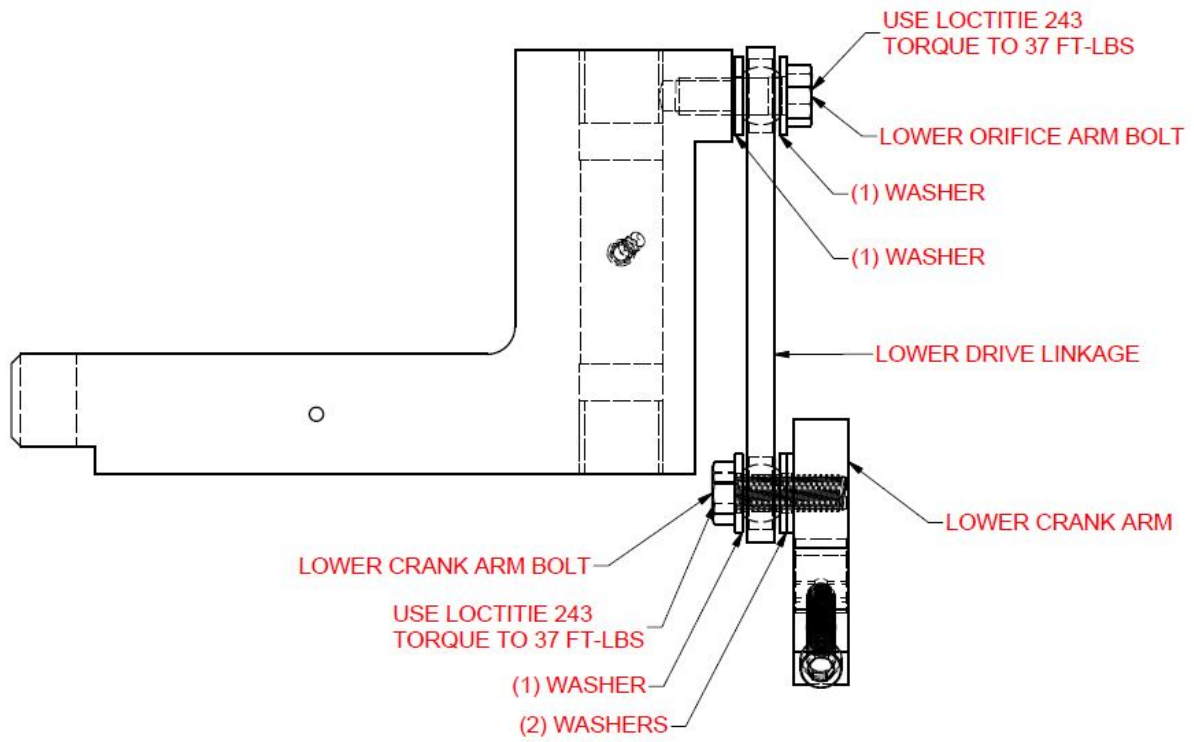

Figure 22. Completed Assembly of Lower Drive Arm

Rebuilding (Continued)

10. Remove sleeve bearings from main frame.

Refer to Figures 23 and 24.

The outer upper drive shaft bearing can be removed using puller, 1-1/2" removal slug, and short threaded removal rod.

The inner bearing can be removed the same way, or can be pressed out using driver. The lower shaft bearing can be removed the same way except using 1" removal slug. New bearings can be installed by compression (**Figure 25**) by using installation pilot, installation washer, and long threaded installation rod. Light coat of Teflon grease can be used on outer diameter of bearings to aid in installation.

11. There are thrust washers next to each bearing on the main frame. Make sure the old ones have been removed and new ones installed.

One side of thrust washer is plain metal. Silicone this side and glue them to the frames (Typical 4 places).

DO NOT get silicone on surface of any bearing. **Refer to Figure 26.**

12. Before reassembling, check all shafts for excessive wear; replace as necessary.

Reassemble parts in the reverse order of removal. **DO NOT** forget to put keys back into crank arms.

On both crank arms, be sure to tighten socket head cap screw first. And then the set screw.

Tighten fasteners to torques shown.

Lubricate all grease fittings if provided.

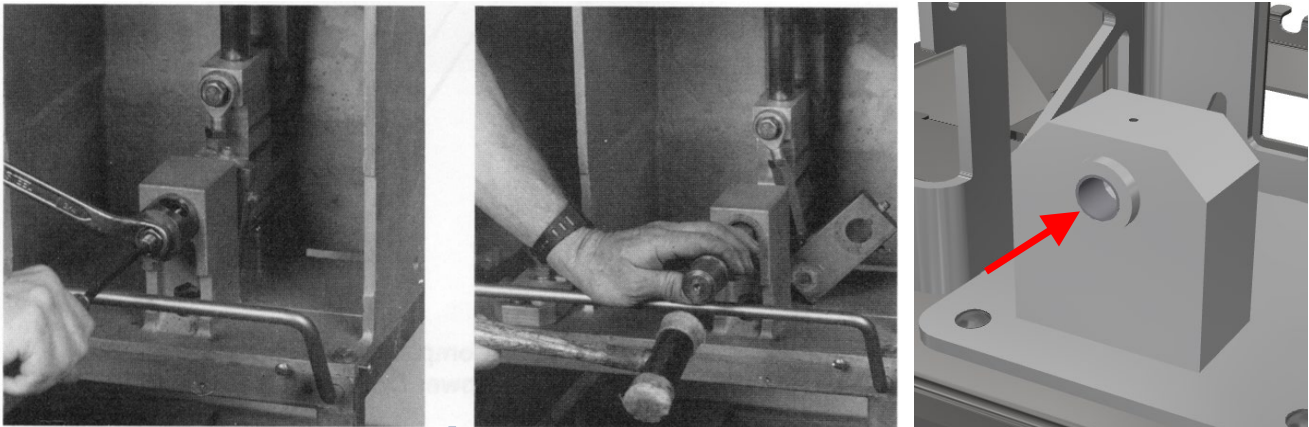
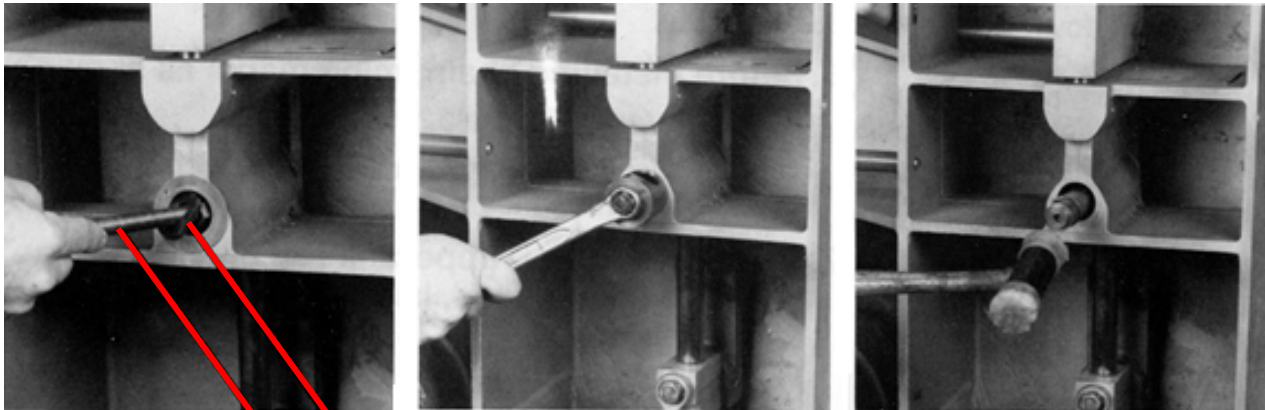

Figure 23. Removing Bearing from Lower Rotary Drive



Bearing Removal Rod

Bearing Removal Slug 1-1/4"

Figure 24. Removing Bearing from Upper Rotary Drive

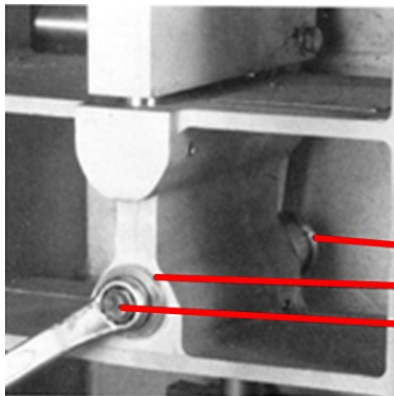

Installation Pilot
Installation Washer
Bearing Installation Rod

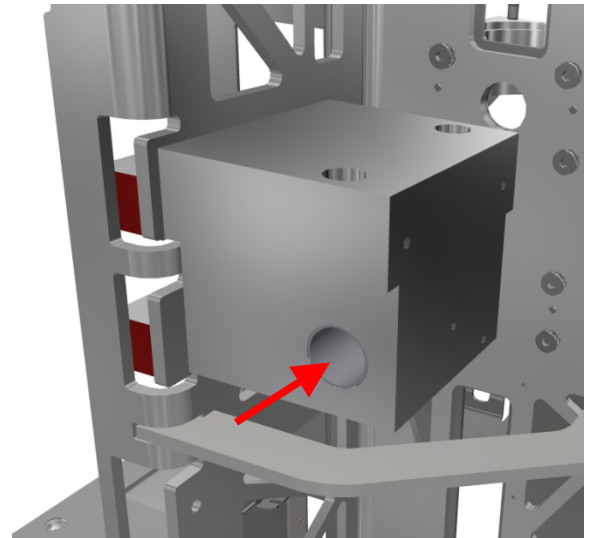
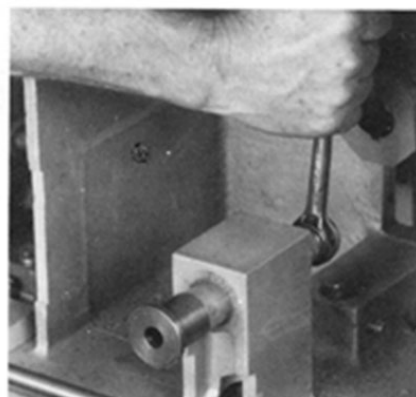
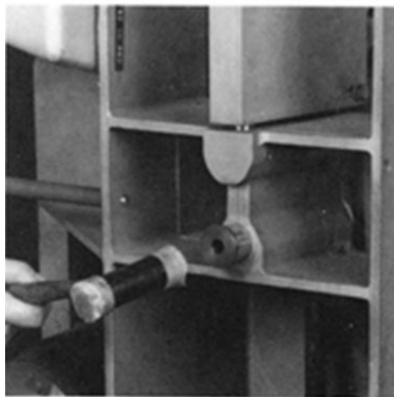

Figure 25. Installation of Bearings and Thrust Washers

Rebuilding (Continued)

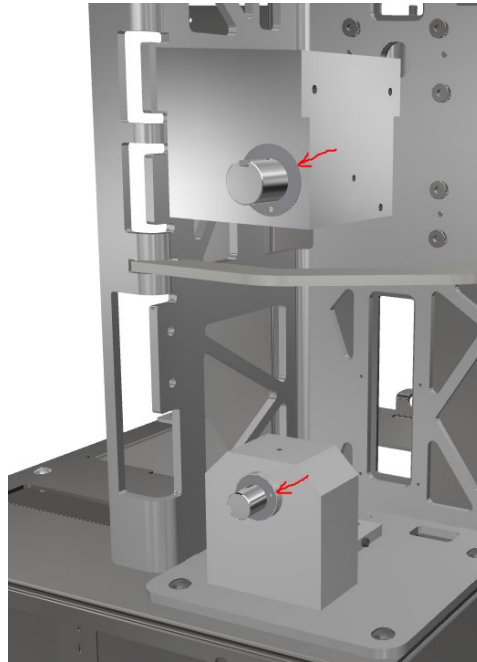

Figure 26. Thrust Washer on Both Sides

- 13. Before installing chain, align timing marks as shown.
Refer to Figure 27.**

This is critical to operation of the machine. Adjust chain as shown in Maintenance section.

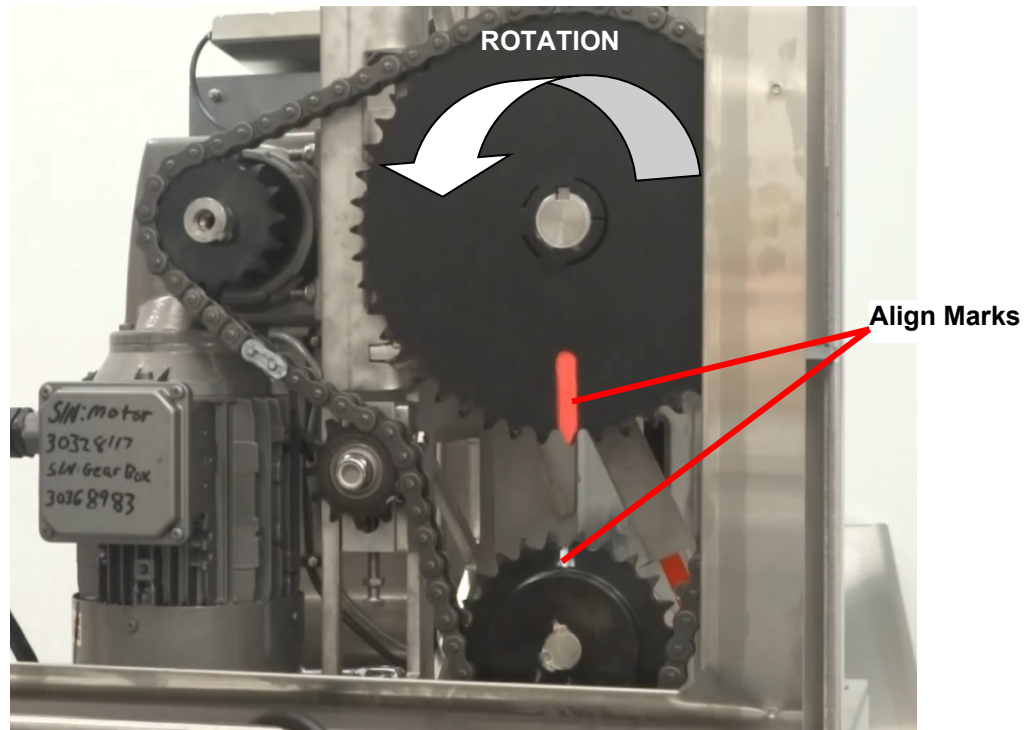

Figure 27. Alignment of Timing Marks



Rebuild Tooling Kit & Spare Parts Kit, 06010509

<u>Item</u>	<u>Part Number</u>	<u>Description</u>
1	06010527	Tool, Bearing Installation Pilot
2	06010528	Tool, Bearing Installation Washer
3	06000182	Tool, Bearing Puller
4	06000183	Tool, Bearing Removal Slug 1"
5	06010507	Tool, Bearing Removal Slug 1-1/2"
6	06010508	Tool, Bearing Removal Driver
7	06000186	Tool, Bearing Installation Rod
8	06000187	Tool, Bearing Removal Rod
9	06000188	Tool, Washer, Rod End, 1/2"
10	06000189	Tool, Washer, Rod End, 5/8"
12	06010400	Tool, Adapter, Hand Crank
13	004350648	Screw, Cap, Hex, 5/8-11 x 1-1/2", C/G
14	004350571	Screw, Cap, Hex, 1/2-13 x 1-1/2", Full Thread, C/G
15	004110063	Nut, Hex, 1/2-13, Grade 8 Steel
16	004815100	Washer, Plain Narrow, 1/2", C/G
17	004815080	Washer, Plain Narrow, 3/8", C/G
18	004350407	Screw, Cap, Hex, 3/8-16 x 2", C/G
19	009733032	Bit, Drilled Spanner #14, 1/4 Hex (Not Pictured)
20	009998004	Bit, Spanner Insert, #8, 1/4 Hex
	06010509	Kit, Tool, CJ & MFJ (Includes above Items 1 - 20)

Other Multi-Fruit Juicer Kits

06010510 Kit, Complete Overhaul w/ shafts

Cleaning Components & Other Parts

009080326 Brush, 1-1/16" x 8"
003091001 CorKlean Cleaner
009710031 Stone, Sharpening
003460053 Lubricant, W/ Teflon, 3 Oz Tube
003460057 Lubricant, W/ Teflon, 14 Oz Can
003015905 Silicone, White, 3 Oz Tube
009092018 Cutter Cap



Figure 28. Rebuild Tool Kit

Illustrated Parts Lists

Assembly drawings in this chapter provide a list of part numbers for replaceable parts available for the 2nd Generation Multi-Fruit Juicer. The following parts list/drawings are provided:

Parts List / Parts Drawing	Page
1. Cart, Tool Holder Mounting	46
2. Main Stainless Steel Center Frame	47
3. Center Plate	48
4. Cup Mounting Blocks, Lower Cup	49
5. Centering Drive Block	50
6. Motor Mount Blocks	51
7. Bottom Bearing Block, Orifice Tube Block	52
8. Rotating Assembly, Lower, 06010471	53
9. Rotating Assembly and Upper, 06010470	54
10. Sliding Shafts	55
11. Rotating Shafts, Thrust Bearings	56
12. Wiring Routing Tabs, Weld Stubs	57
13. Chain Tensioner	58
14. Chain, Sprocket and Motor Mounting	59
15. Grease Fittings	60
16. Splash Guards	61
17. Splash Shield Guides, Fruit Guides	62
18. Fruit Lift, Hopper Mounting	63
19. HMI Mounting, Proximity Sensors for Float and TDC	64
20. Electrical Connections	65
21. Hopper	67
22. Hopper Top Cover, Lid and Sensors	68
23. Panels, Left and Rear	69
24. Service Panel, Right Panel	70
25. Decals (Standard)	71
26. Decals, 3-Piece, Large Logo (Optional)	72
27. Juicing Components	73
28. Self-Service Juicing Components	74
29. Splash Shield, Waste Bin, Tools and Accessories	75
30. Reservoir and Components	76
31. Doors, Latches and Hinges	77
32. Auto Lubrication Parts (Optional)	78



Cart, Tool Holder Mounting

<u>Item</u>	<u>Qty</u>	<u>Part Number</u>	<u>Description</u>
1	1	06010103	Cart Assembly
2	1	06010291	Tool Holder

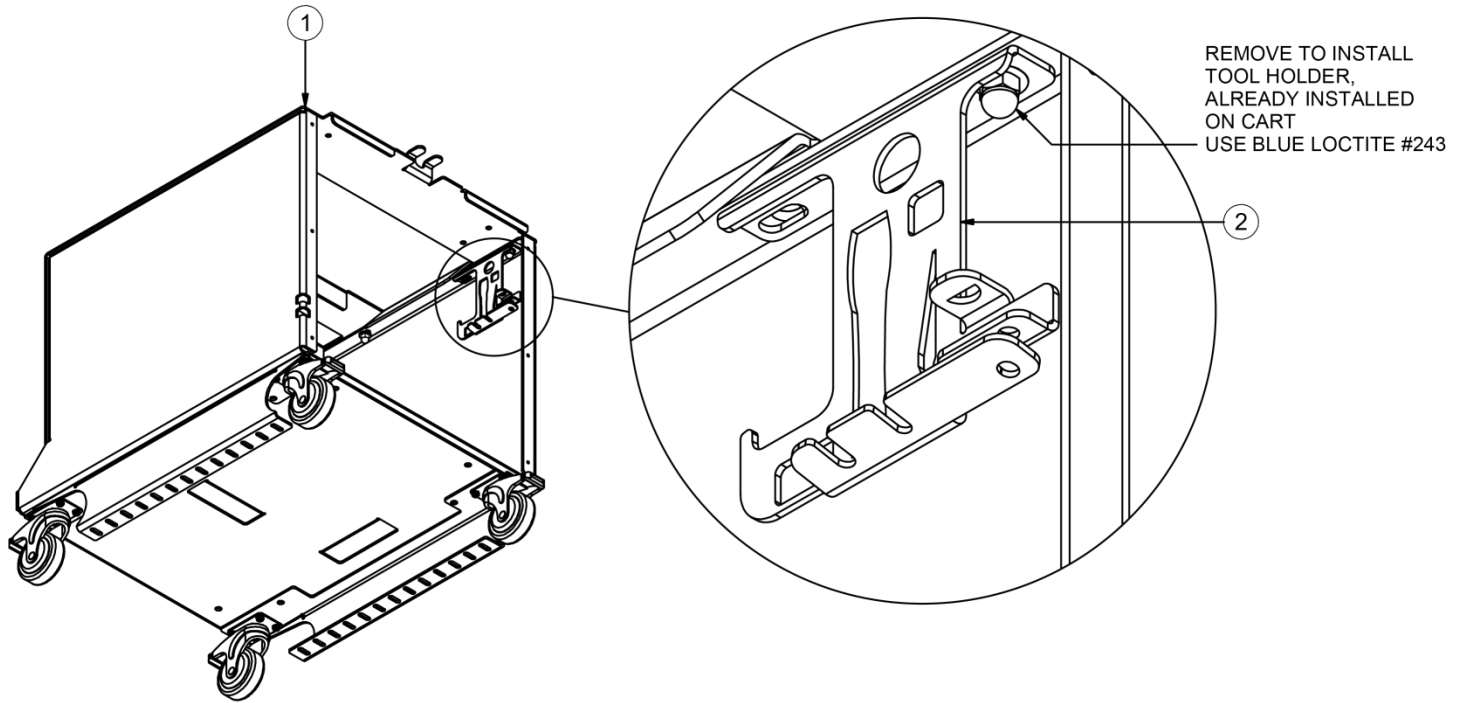

NOTES:

1. FOLLOW TORQUE AND THREAD COATING INSTRUCTIONS.
2. USE EXISTING HARDWARE TO MOUNT TOOL HOLDER.

Figure 29. Cart, Tool Holder Mounting

2. Main Stainless Steel Center Frame

<u>Item</u>	<u>Qty</u>	<u>Part Number</u>	<u>Description</u>
1	12	004011032	Bolt, Carriage, 3/8-16 X 1-1/4" Lg, 304SS
2	9	004156074	Nut, Hex, S/L, Light, 3/18-16, 304SS
3	19	004816086	Washer, Flat, 3/8", SS
4	1	06010231	Frame, 2nd Gen MFJ, Machined

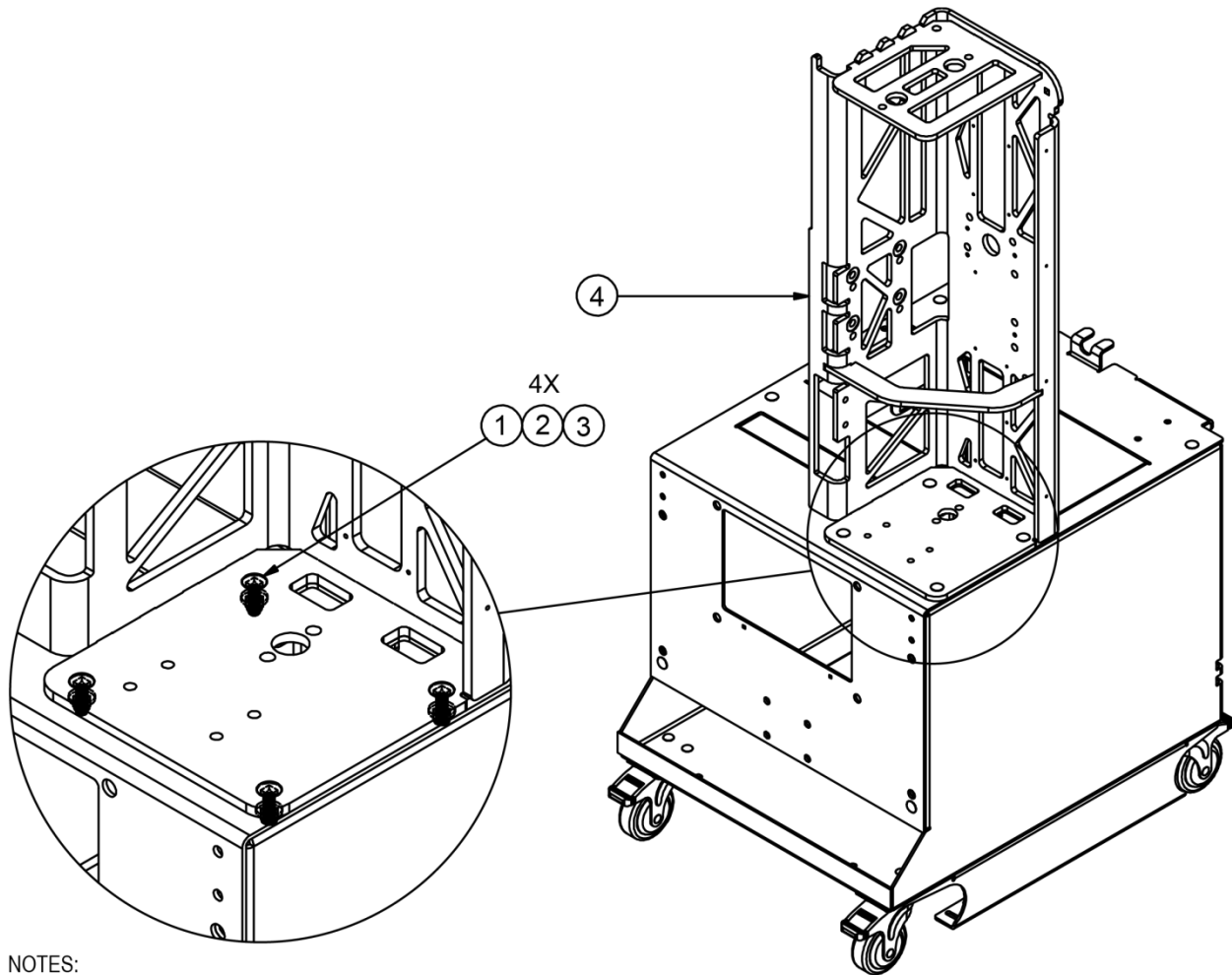

NOTES:

COAT ALL THREADS AND RECEIVING THREADS WITH A THIN LAYER OF ANTISEIZE.

Figure 30. Main Stainless Steel Center Frame



3. Center Plate

<u>Item</u>	<u>Qty</u>	<u>Part Number</u>	<u>Description</u>
1	12	004011032	Bolt, Carriage, 3/8-16 X 1-1/4" Lg, 304SS
2	1	004156072	Nut, Hex, S/L, Heavy, 3/18-16, 304SS
3	7	004156074	Nut, Hex, S/L, Light, 3/18-16, 304SS
4	15	004816086	Washer, Flat, 3/8", SS
5	1	06010194	Plate, Formed, Juicing Area

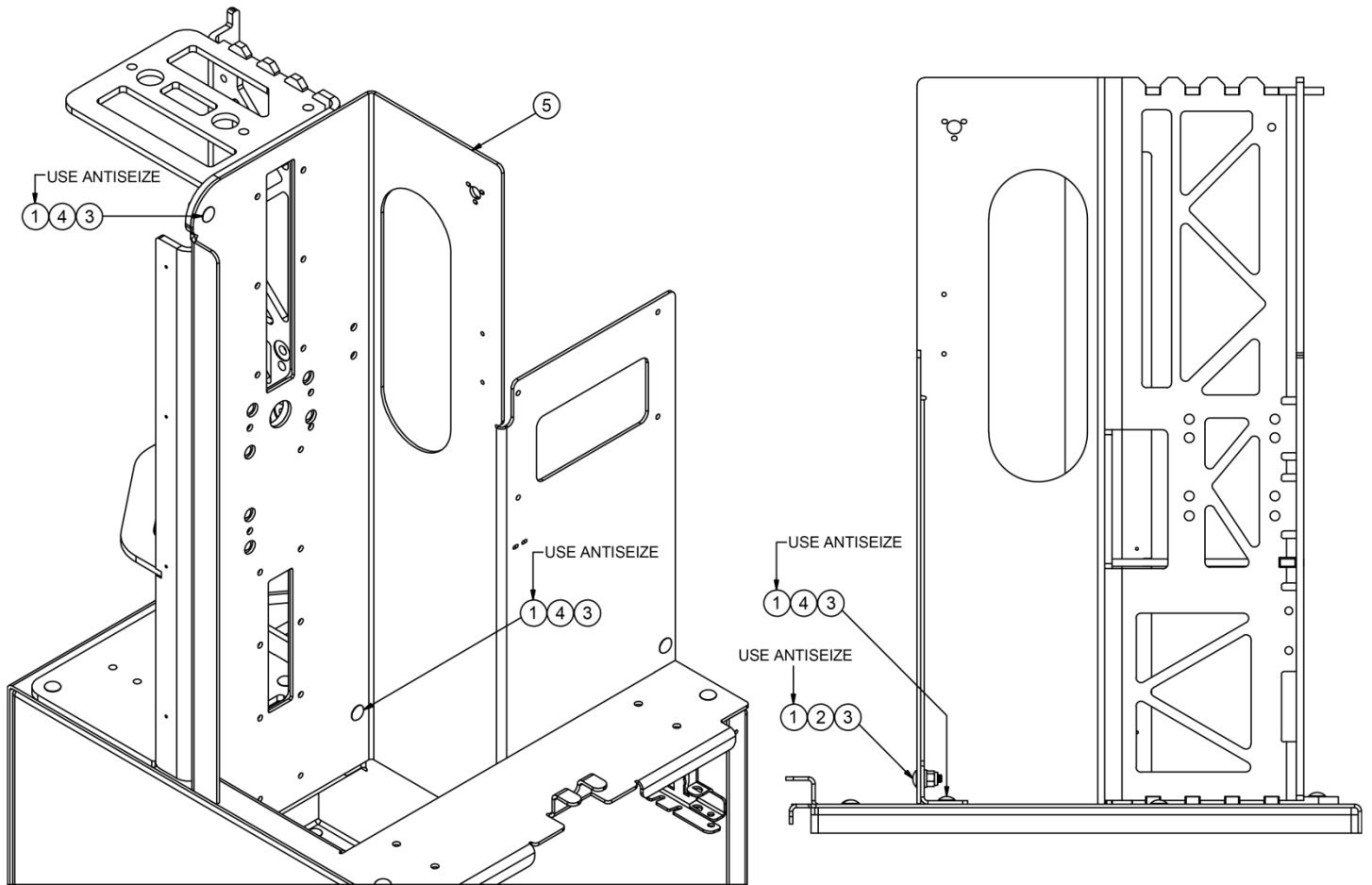

NOTES:
FOLLOW THREAD COATING AND TIGHTENING INSTRUCTIONS.

Figure 31. Center Plate

4. Cup Mounting Blocks, Lower Cup

Item	Qty	Part Number	Description
1	2	004210030	Pin, Dowel, 3/8" Diameter X 7/8" Lg, 304SS
2	4	004210044	Pin, Dowel, 1/4" Diameter X 1-1/8" Lg, SS
3	6	004415013	Screw, Shoulder, 3/8" X 5/8" Lg, 1/2" Shoulder, 18-8SS
4	1	06010227	Cup Mount, LH
5	1	06010232	Cup Mount, RH

APPLY A SMALL BEAD OF SILICON ON MATING SURFACE, 0.25" OFFSET FROM PERIMETER OF CUP MOUNT BEFORE INSTALLING TO CREATE SANITARY SEAL. WIPE EXCESS SILICON.

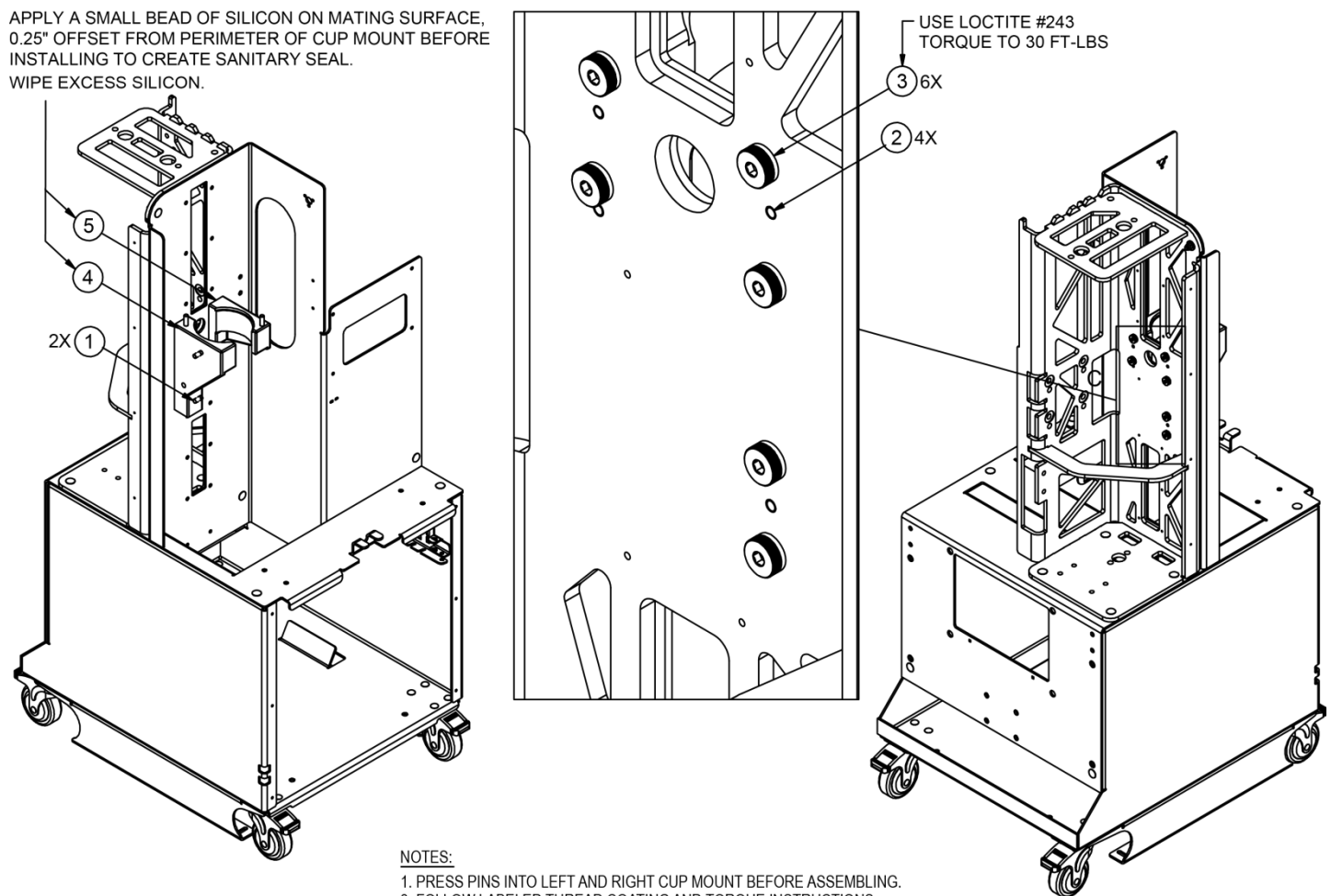

Figure 32. Cup Mounting Blocks, Lower Cup



5. Centering Drive Block

<u>Item</u>	<u>Qty</u>	<u>Part Number</u>	<u>Description</u>
1	4	004415014	Screw, Shoulder, 1/2" X 3/4" Lg, 3/8-16 Thread, 18-8SS
2	4	06010069	Spacer, Alignment Block

USE LOCTITE #243
TORQUE TO 30 FT-LBS

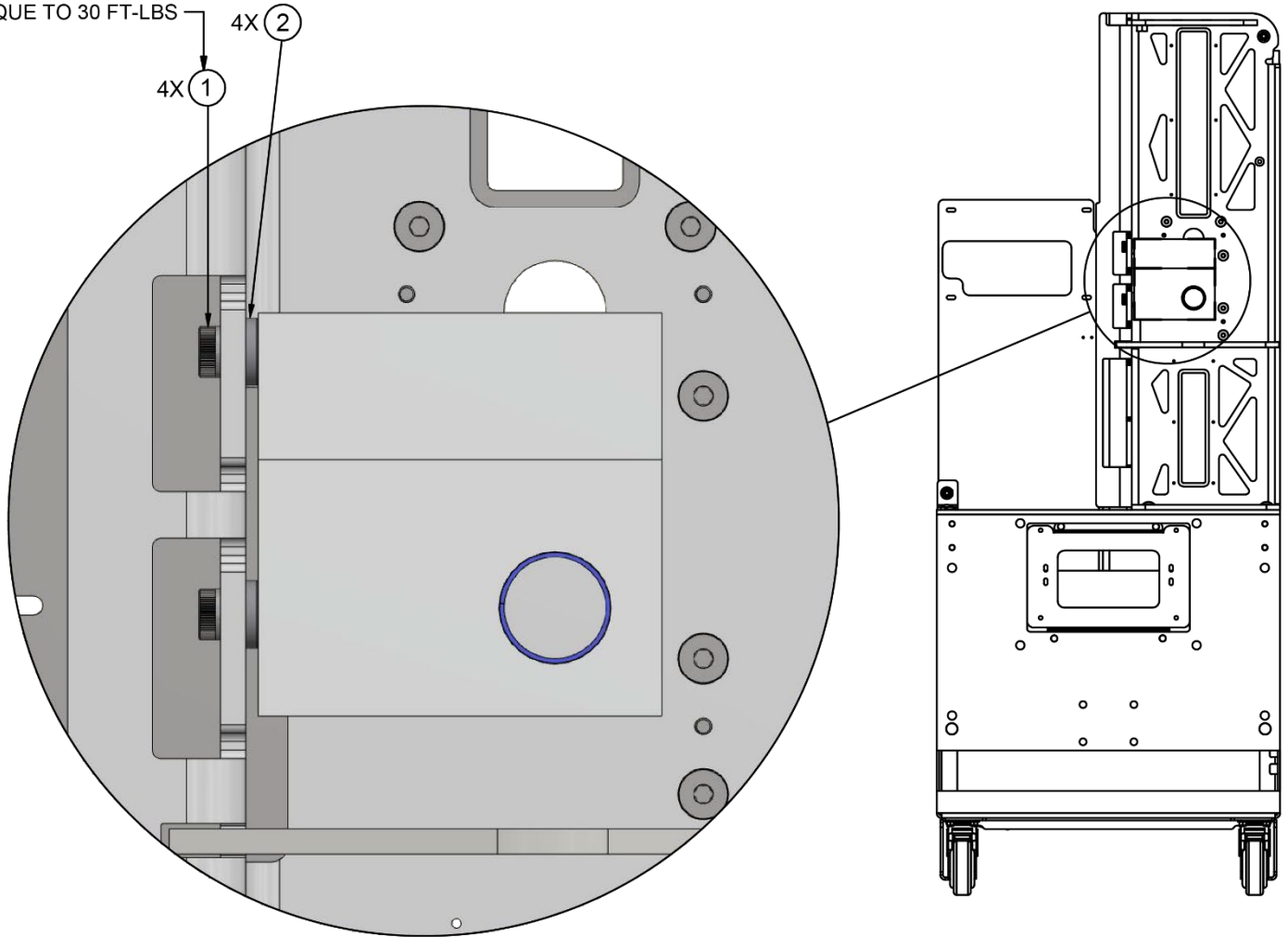
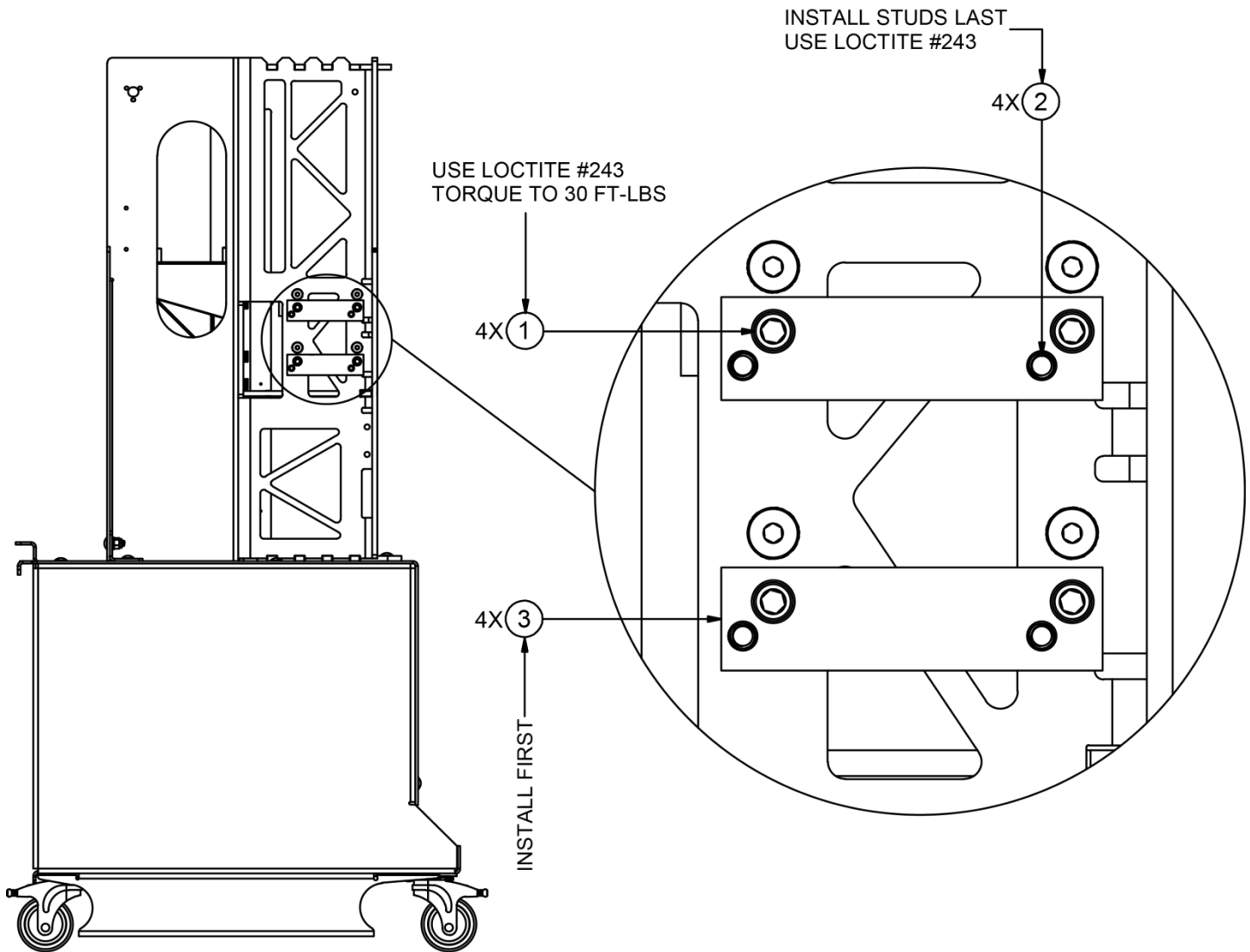

Figure 33. Centering Drive Block

6. Motor Mount Blocks

<u>Item</u>	<u>Qty</u>	<u>Part Number</u>	<u>Description</u>
1	4	004415051	Screw, Socket Head, 3/8-16 Thread, 3" Lg, 18-8SS
2	4	004701002	Stud, Fully Threaded, 3/8-16, 2-1/4" Lg, 18-8SS
3	2	06010071	Spacer, Right Angle Motor Mounting



NOTES:

1. FOLLOW LABELED THREAD COATING AND TORQUE INSTRUCTIONS.
2. FOLLOW LABELED ORDER INSTRUCTIONS.

Figure 34. Motor Mount Blocks



7. Bottom Bearing Block, Orifice Tube Drive Block

<u>Item</u>	<u>Qty</u>	<u>Part Number</u>	<u>Description</u>
1	1	003030296	Bar, Flat, Aluminum, 3" X 5"
2	4	004352397	Screw, Cap, Hex, Full Thread, 3/8-16 X 1-1/2", SS
3	16	004806070	Washer, Lock, 3/8" Reg, SS

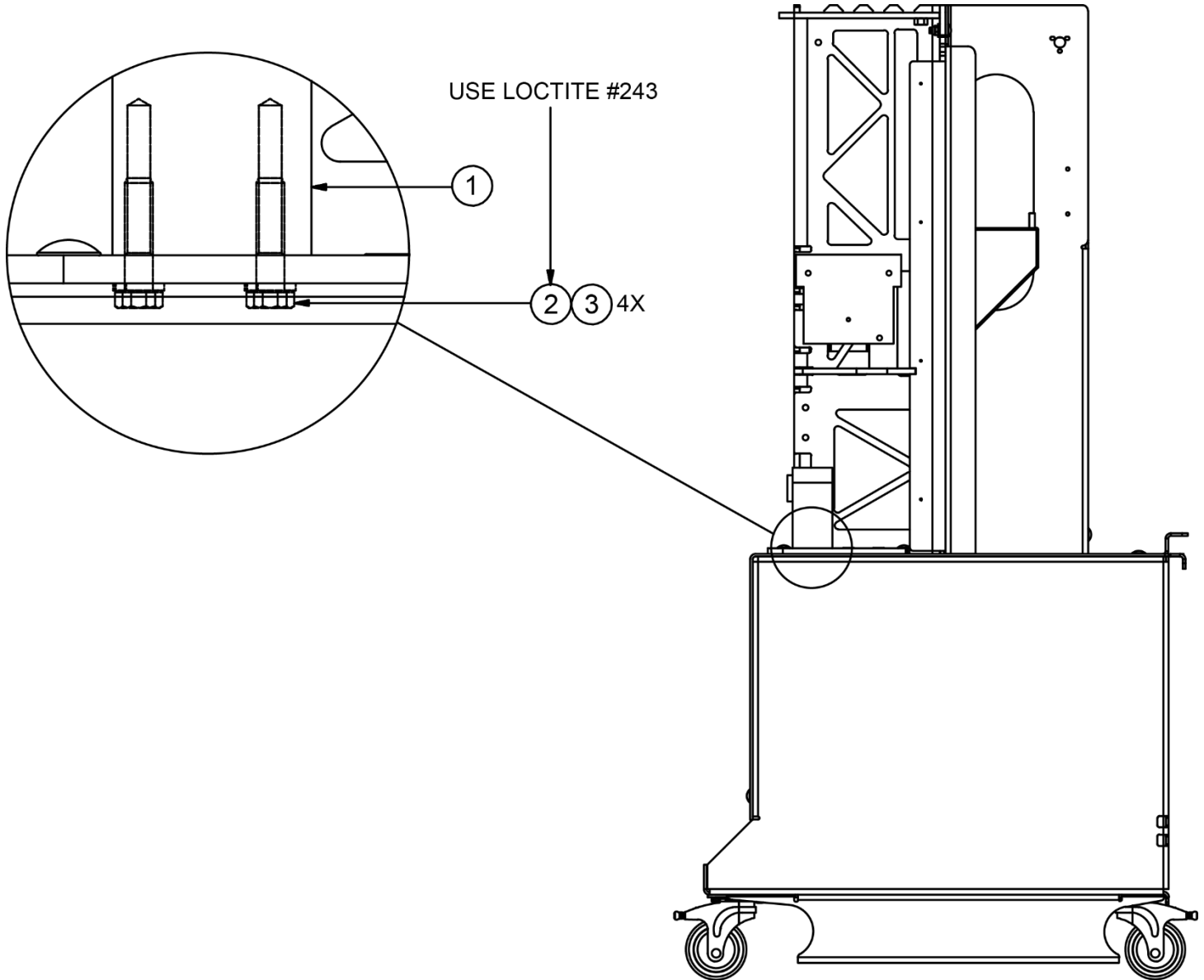

NOTES:

1. FOLLOW LABELED THREAD COATING AND TORQUE INSTRUCTIONS.

Figure 35. Bottom Bearing Block, Orifice Tube Drive Block

8. Rotating Assembly, Lower, 06010471

Item	Qty	Part Number	Description
1	1	004355051	Screw, Socket Head,3/8-16
2	1	004541138	Screw, Set 3/8-16
3	1	06000058	Crank, Orifice Tube Drive
4	5	004816100	Washer, Flat
5	1	06010175	Assembly, Arm, Link, Orifice Drive
6	1	004352571	Screw, Cap, Hex, 1/2-13
7	1	06000011	Arm, Orifice Tube Drive
8	1	004352572	Screw Cap Hex 1/2-13, Left-Hand Thread
9	2	005098731	Bushing 1" ID X 1"LG

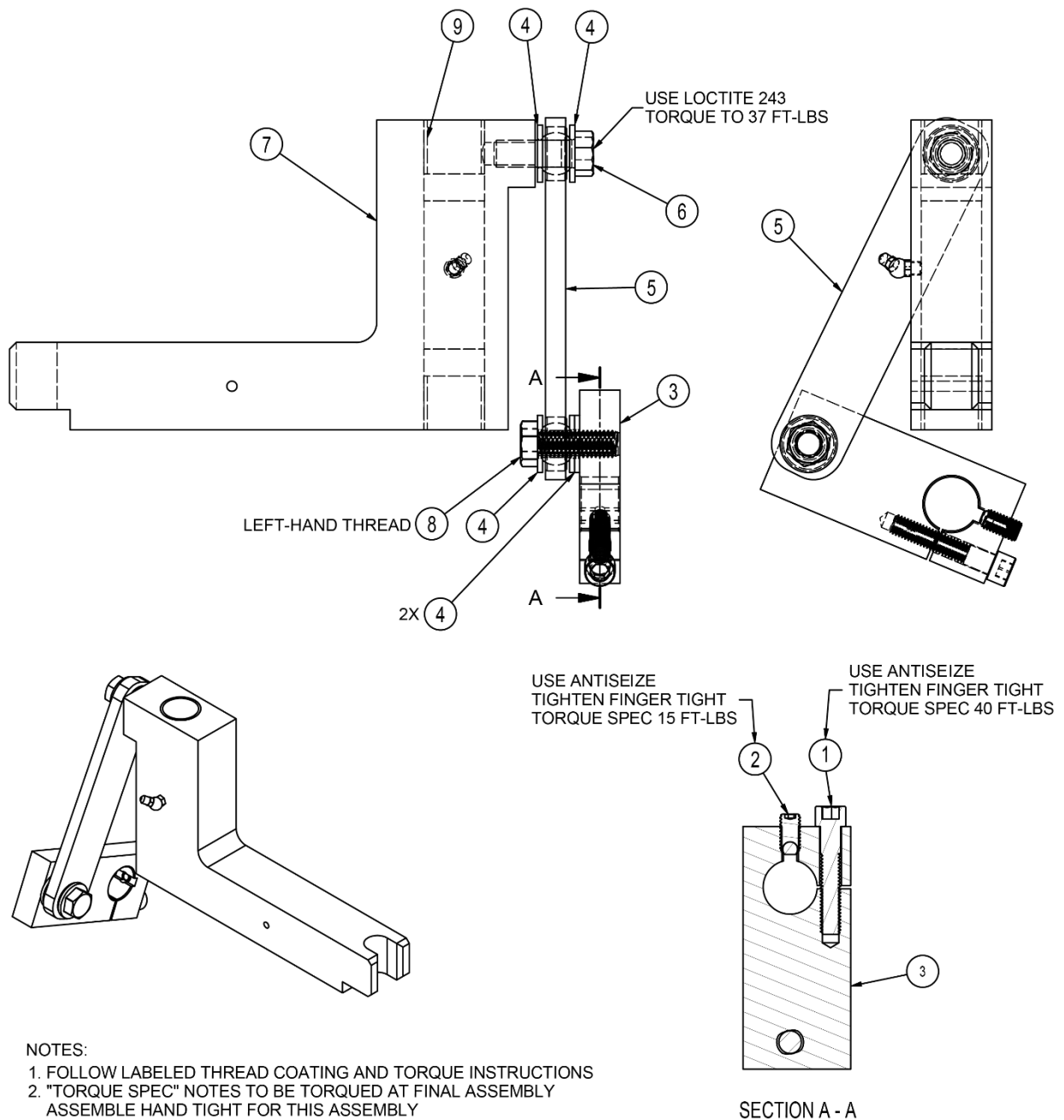

Figure 36. Rotating Assembly, Lower, 06010471



9. Rotating Assembly and Upper, 06010470

Item	Qty	Part Number	Description
1	1	06010242	Crank, Upper Cup Drive
2	1	004541138	Screw, Set 3/8-16
3	1	004356109	Screw, Socket Head,3/8-16
4	6	004816120	Washer Flat
5	1	06010174	Assembly, Arm, Link, Upper Cup
6	1	06000030	Arm, Upper Cup Drive
7	1	06010258	Screw - U.C. Crank, Left-Hand Thread
8	1	06000057	Lock - Rod End
9	1	06010323	Upper Cup Arm Bolt
10	1	007143009	Magnet TDC
11	1	004385057	Screw, Flat Hd,#8-32
12	4	005098731	Bushing 1" ID X 1"LG

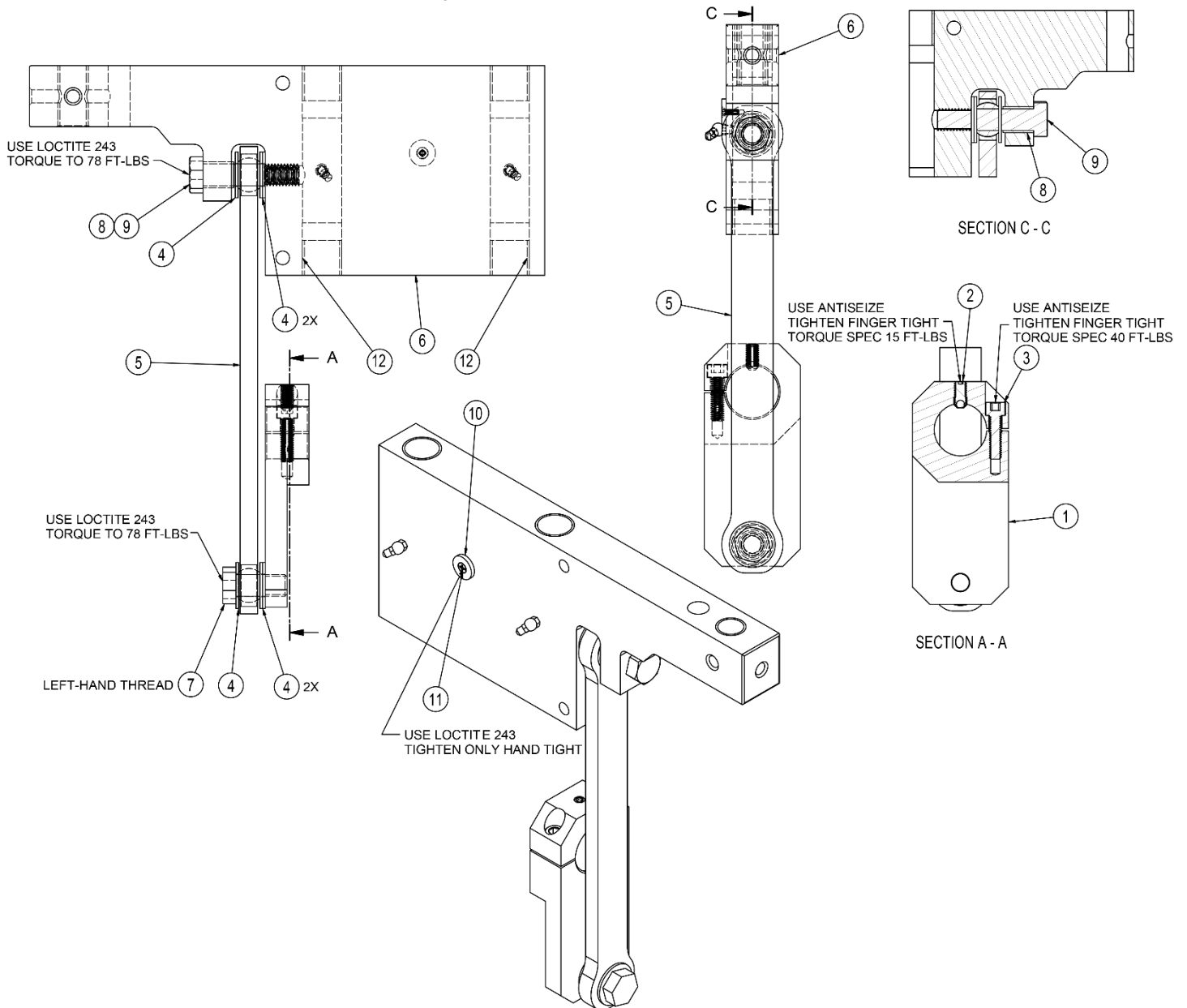
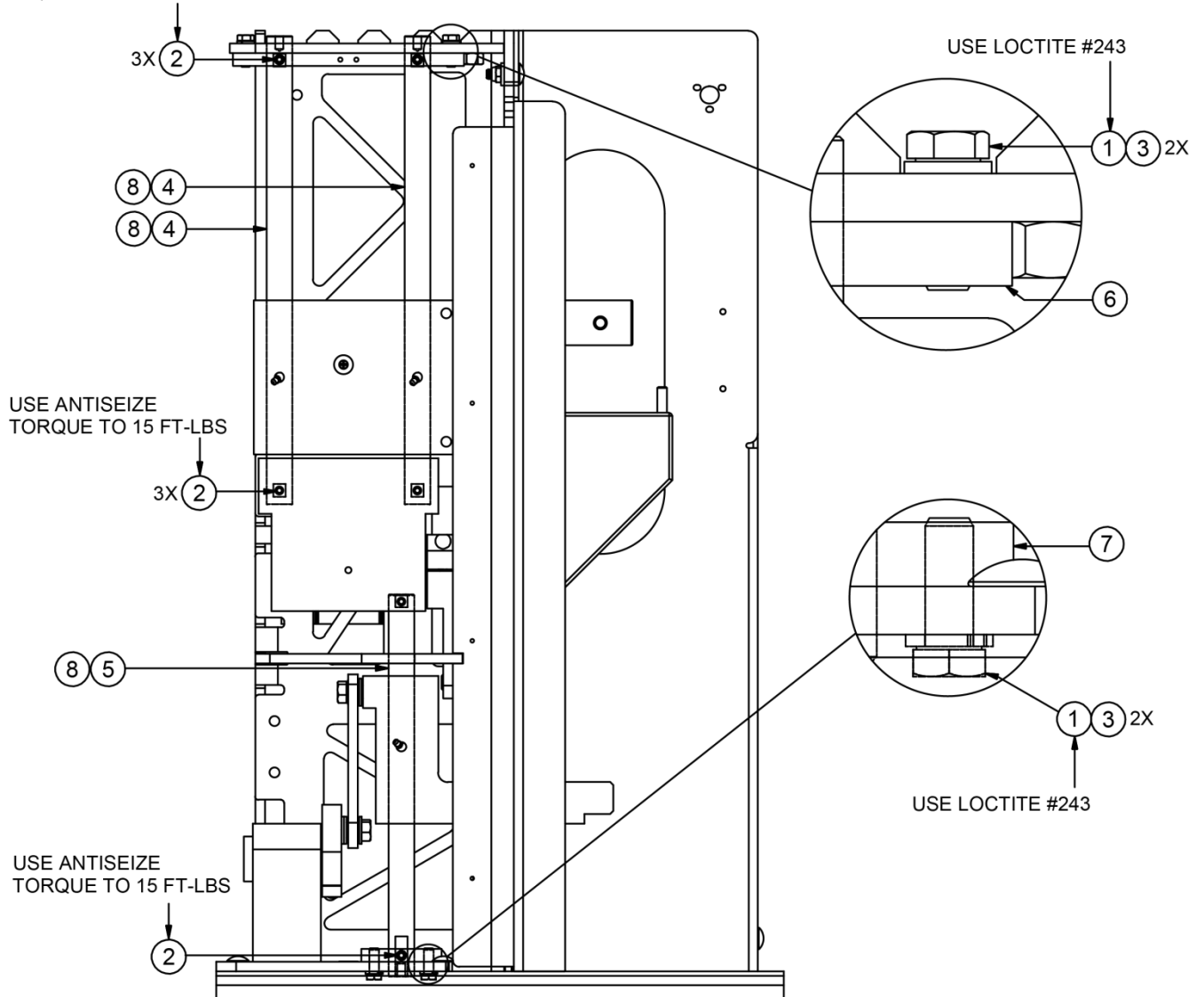

Figure 37. Rotating Assembly and Upper, 06010470

10. Sliding Shafts

Item	Qty	Part Number	Description
1	5	004352395	Screw, Cap, Hex, 3/8 X 1, SS
2	9	0043541138	Screw, Cap, Hex, Socket Set Cup Point, 3/8-16
3	16	004806070	Washer, Lock, 3/8" Reg, SS
4	2	06000064	Upper Cup Drive Linear Shaft
5	1	06000063	Linear Orifice Drive Shaft
6	1	06010064	Block, Guide, Upper Cup Guide Rods
7	1	06010065	Block, Guide, Orifice Rod
8	6	005098731	Bearing, 1"

USE ANTISEIZE
TORQUE TO 15 FT-LBS



NOTES:

1. FOLLOW THREAD COATING AND TORQUE INSTRUCTIONS.
2. INSTALL UPPER SHAFTS FIRST.
3. LEAVE UPPER SHAFT EDGE BOLTS LOOSE.
SLIDE CUP DRIVE ARM UP, THEN TIGHTEN BOLTS.

Figure 38. Sliding Shafts

11. Rotating Shafts, Thrust Bearings

Item	Qty	Part Number	Description
1	2	005062805	Thrust Washer, 1-1/2" ID
2	2	005098112	Thrust Washer, 1" ID
3	1	005576061	Key, Square, 1/4" X 3/4" Lg, 416SS
4	2	005576286	Key, Square, 3/8" X 1-1/4" Lg, 304SS
5	1	06000061	Shaft, Rotary Orifice Drive
6	1	06006101	Rotary Main Drive Shaft
7	2	005098731	Bearing, 1"
8	2	005098772	Bearing, 1-1/2"
9	1	005576242	Key, Square, 1/4" X 1" Lg, 416SS

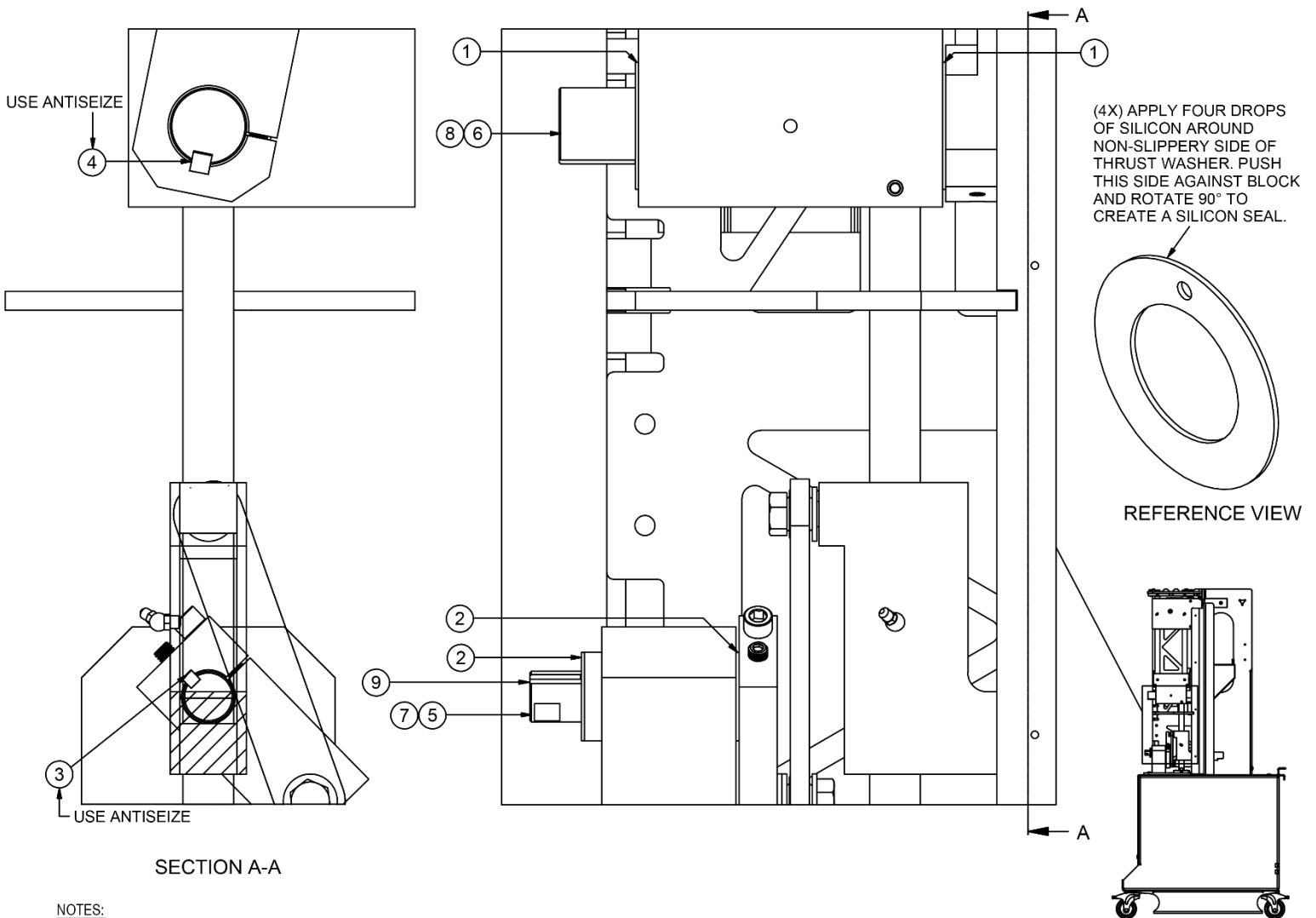

NOTES:

1. COAT ALL SHAFTS AND RECEIVING HOLES WITH A THIN LAYER OF ANTISEIZE.
2. FOR EACH THRUST WASHER, PLACE 4 DROPS OF SILICONE ON SIDE WITHOUT THE SLIDING SURFACE. MATE ONTO SURFACE SLIDING SIDE AWAY FROM BLOCK. PUSH AND ROTATE 90° TO SMEAR SILICONE AND CREATE BOND.
3. TIGHTEN CRANK ARM BOLTS AND CRANK KEY SET SCREWS TO THE SPECIFIED TORQUE SPECS NOW, USING SPECS SHOWN ON ROTATING ASSEMBLY DRAWING, FIG 17.

Figure 39. Rotating Shafts, Thrust Bearings

12. Wiring Routing Tabs, Weld Stubs

<u>Item</u>	<u>Qty</u>	<u>Part Number</u>	<u>Description</u>
1	18	004705106	Stud, Weld, Threaded Flange, #10-24 X 3/4" Lg, SS
2	20	004156041	Nut, Hex, S/L, #10-24, SS
3	5	006270314	Clamp, Chemical Resistant, 7/16" ID, 1" Line
4	1	006270317	Clamp, Chemical Resistant, 1/4" ID, 1" Line
5	3	006270318	Clamp, Chemical Resistant, 7/16" ID, 2" Line
6	9	006270319	Clamp, Chemical Resistant, 1/4" ID, 2" Line

1. USE ANTISEIZE
2. LEAVE LOOSE
UNTIL ELECTRICAL
DRAWING

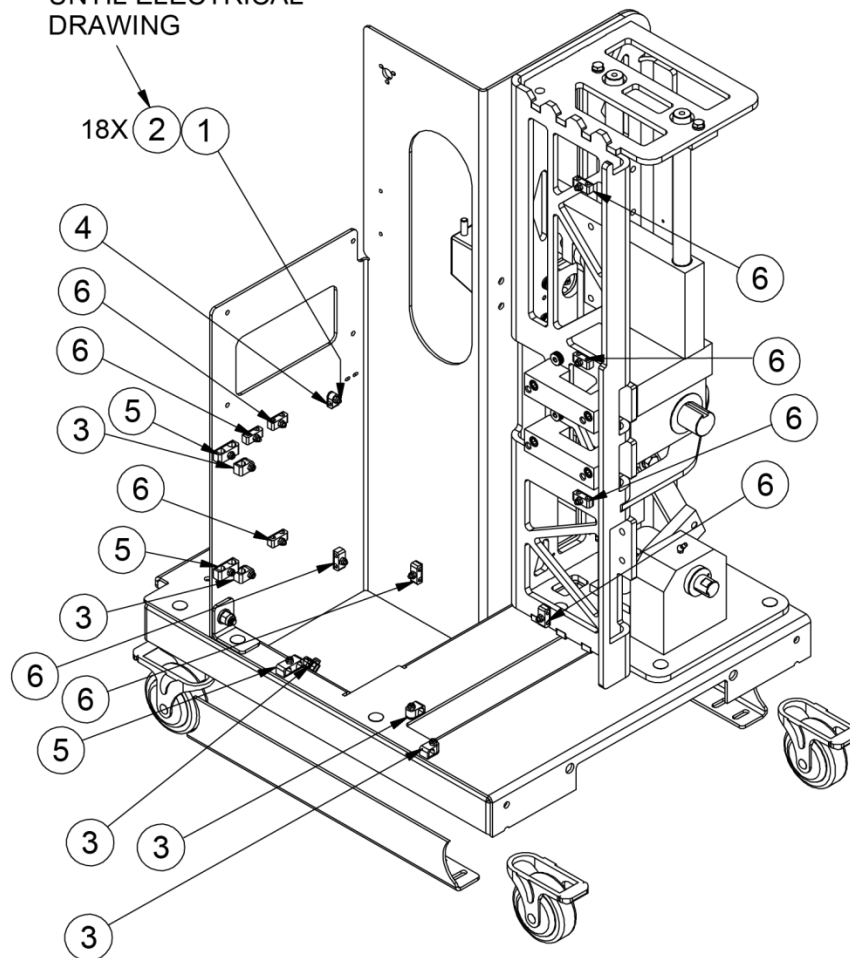

NOTES:

1. SPRAY WELD AREAS WITH ANTI SPATTER FOR EASY CLEANUP AFTER WELDING. THEN WELD.
2. WIGGLE TEST STUDS AFTER WELDING.
3. FOLLOW ALL THREAD COATING AND TORQUE INSTRUCTIONS.

Figure 40. Wiring Routing Tabs, Weld Stubs

13. Chain Tensioner

Item	Qty	Part Number	Description
1	1	004116026	Nut, Jam, 3/8-16, SS
2	1	004156118	Nut, Hex, S/L, Thin, 5/8-11, SS
3	2	004352392	Screw, Cap, Hex, 3/8-16 X 7/8" Lg, 304SS
4	1	004352415	Screw, Cap, Hex, Full Thread, 3/8-16 X 3-1/2" Lg, SS
5	16	004806070	Washer, Lock, 3/8" Reg, SS
6	1	004605030	Spacer, Unthreaded, 1" OD, 3/8" Lg, 5/8" Screw, 18-8SS
7	1	005806374	Sprocket, Idler, #60, 12T, 3/4" P, 1-9/16" Diameter
8	1	06010171	Mount, Chain Tensioner
9	1	06010355	Bolt, Idler Sprocket, Cut to Length
10	1	06010367	Chain Tensioner Washer, 5/8"

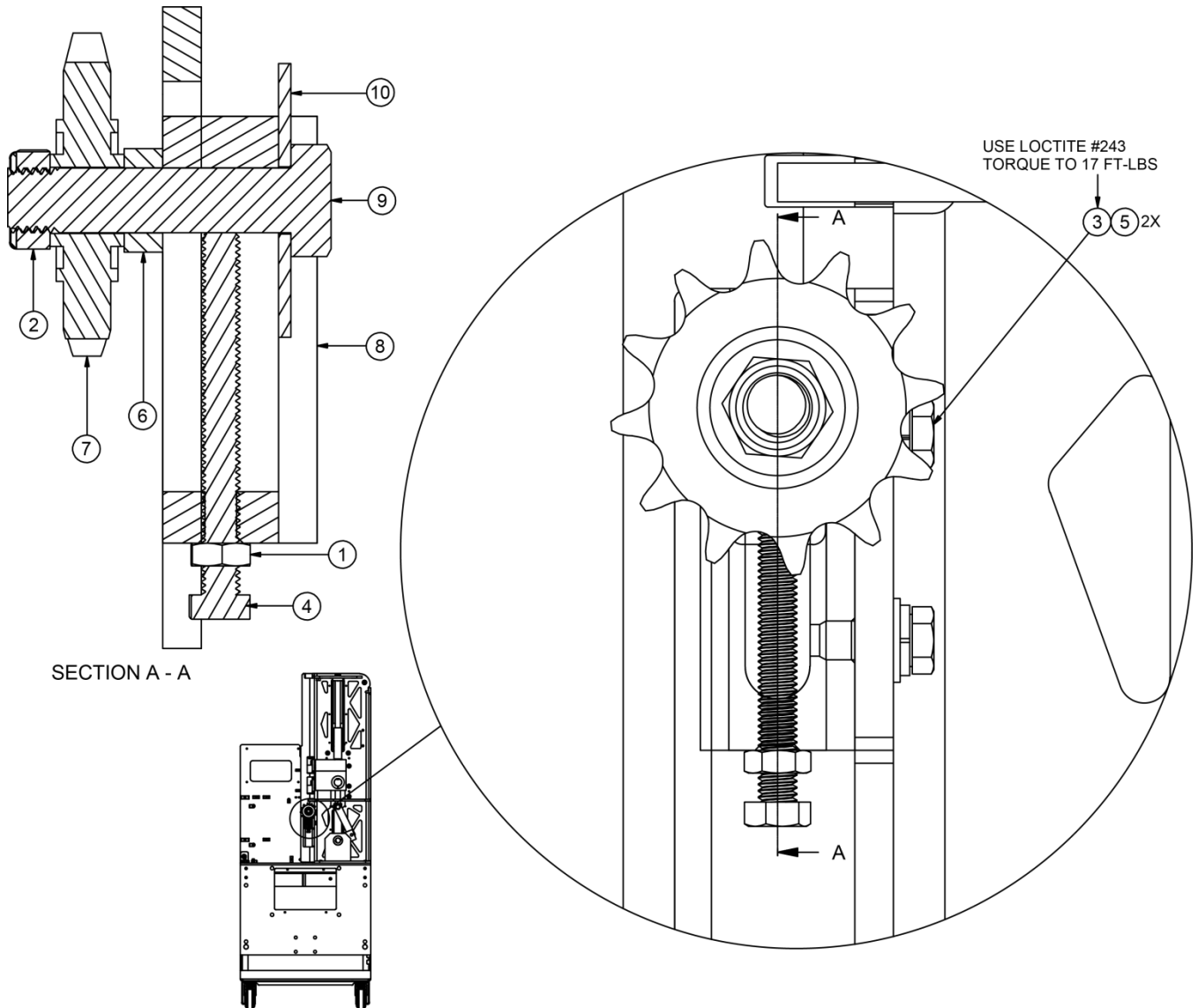

- NOTES:**
1. FOLLOW LABELED THREAD COATING AND TORQUE INSTRUCTIONS.
 2. ENSURE RECTANGULAR TENSIONER WASHER SITS FLAT AGAINST BLOCK BEFORE TIGHTENING!

Figure 41. Chain Tensioner

14. Chain, Sprocket and Motor Mounting

Item	Qty	Part Number	Description
1	4	004110066	Lock Nut, Nylon Insert, Thin, 3/8-16, 18-8SS
2	2	004355051	Screw, Cap, Hex, Socket Head, 3/8-16 X 2" Lg, S/L, Alloy
3	2	004541112	Screw, Set, Hex, S/L, 5/16-18 X 3/4" Lg, C/G
4	9	004541138	Screw, Socket Set, Cup Point, 3/8-16
5	4	004701002	Stud, Fully Threaded, 3/8-16 X 2-1/4" Lg, 18-8SS
6	16	004806070	Washer, Lock, 3/8" Reg, SS
7	1	005220148	Chain, #60, Single Strand, Plus (1) Con, (1) Half Link, Steel
8	1	005576242	Key, Square, 1/4" X 1" Lg, 416SS
9	1	005804235	Sprocket, Wear Resistant, 1-1/4", 16T, ANSI60 Chain
10	1	06000065	Sprocket, Orifice Drive
11	1	06006120	Sprocket, Upper Cup Drive Arm
12	1	005576286	Key, Square, 3/8" X 1-1/4" Lg, 304SS

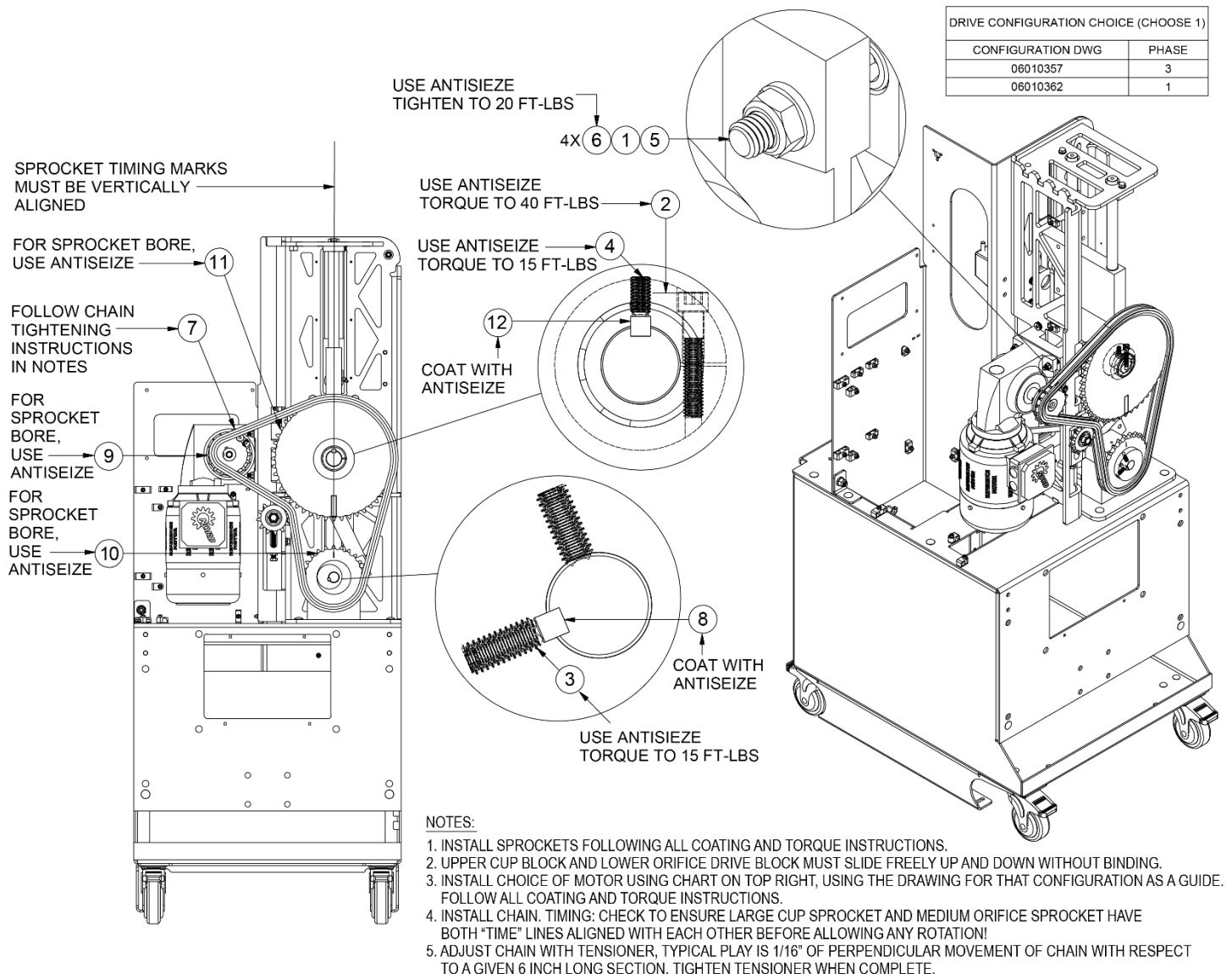
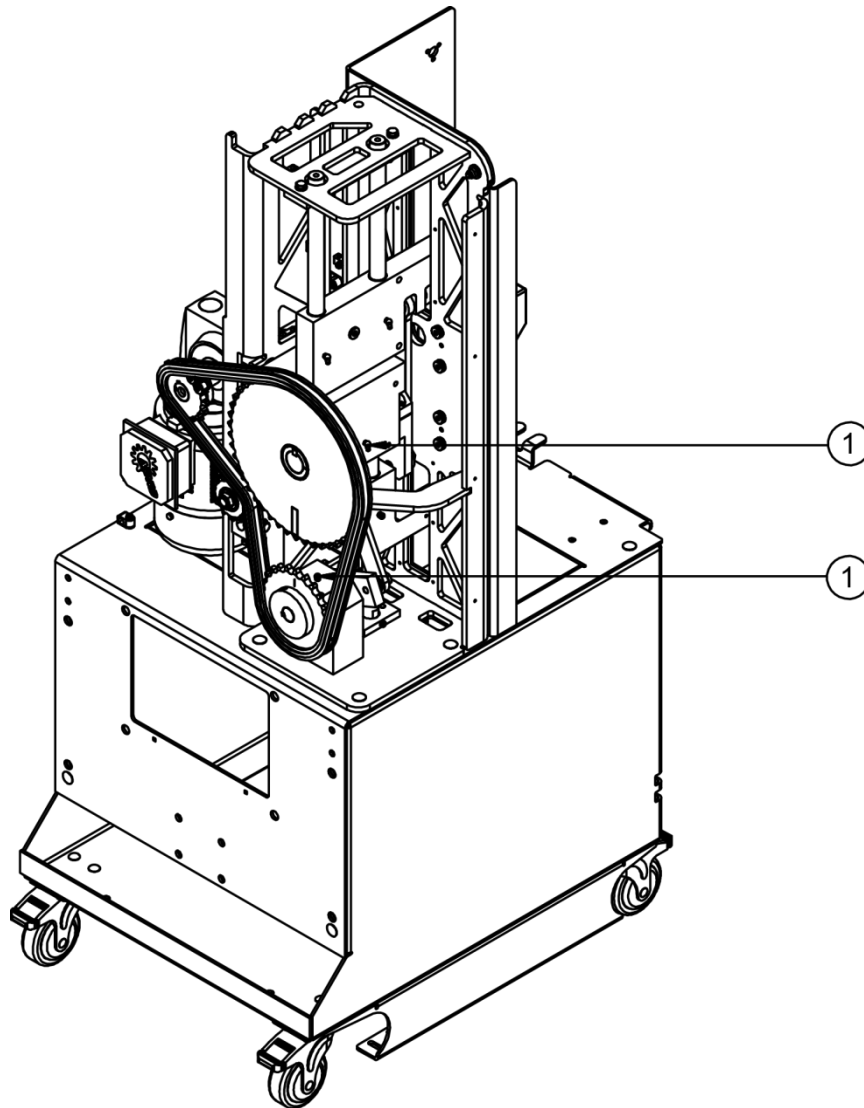

Figure 42. Chain, Sprocket and Motor Mounting

15. Grease Fittings

<u>Item</u>	<u>Qty</u>	<u>Part Number</u>	<u>Description</u>
1	2	007120205	Fitting, Grease, 1/4-28 x 45mm



NOTES:

1. INJECT GREASE ON ALL CONNECTORS. STOP WHEN GREASE SEEPS FROM GAPS.

Figure 43. Grease Fittings

16. Splash Guards

<u>Item</u>	<u>Qty</u>	<u>Part Number</u>	<u>Description</u>
1	20	004156041	Nut, Hex, S/L, #10-24, SS
2	15	004385055	Screw, Machine, Flat Head, #10-24 X 1" Lg, Phillips Head
3	10	004816052	Washer, Plain, #10, SS
4	1	06010216	Splash Guard, Upper
5	1	06010217	Splash Guard, Lower
6	1	06010262	Upper Guard Cover, Upper Splash Guard
7	1	06010263	Lower Guard Base, Lower Splash Guard
8	1	06010264	Lower Guard Cover, Lower Splash Guard

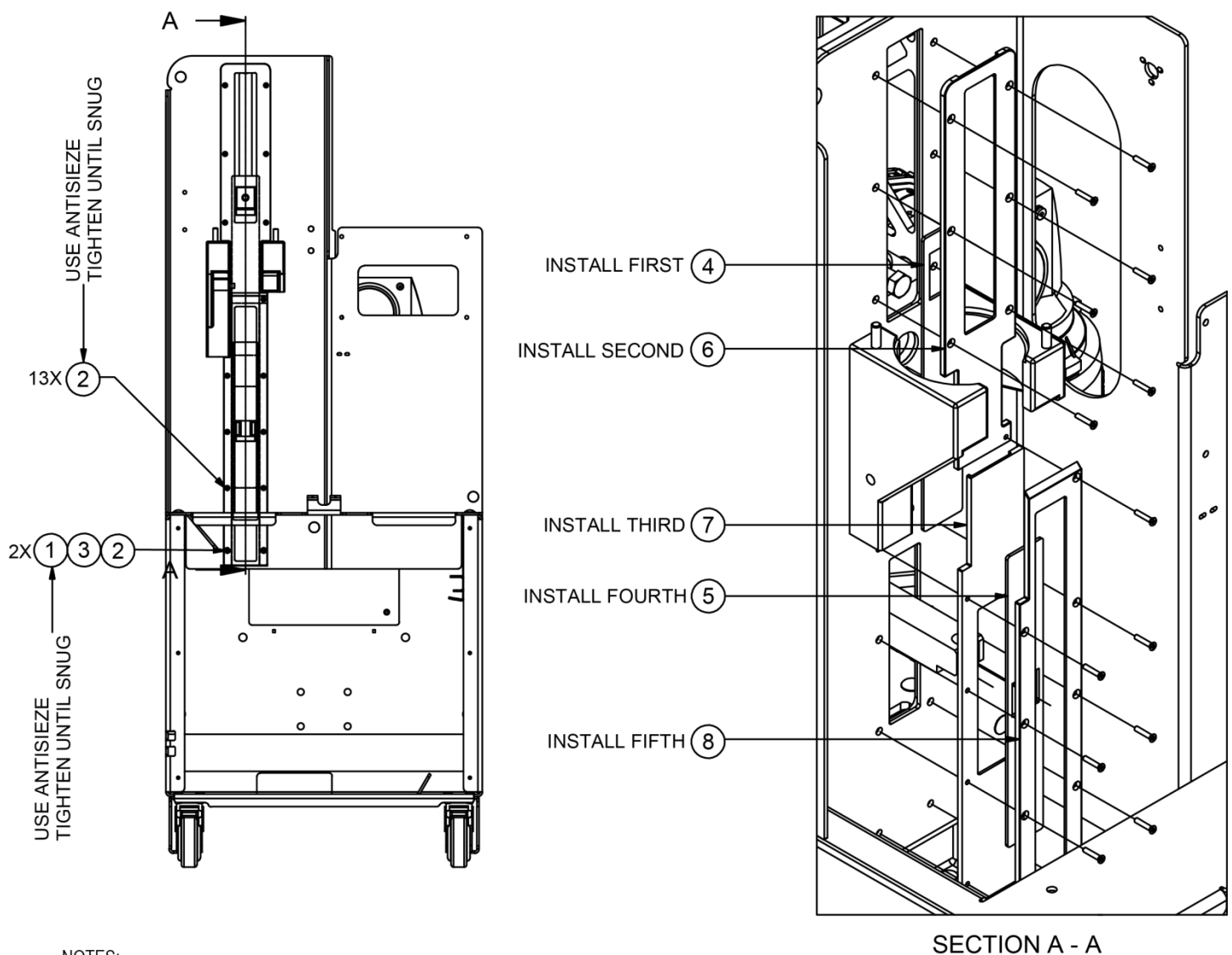

NOTES:

1. FOLLOW LABELED THREAD COATING AND TORQUE INSTRUCTIONS.

Figure 44. Splash Guards



17. Splash Shield Guides, Fruit Guides

Item	Qty	Part Number	Description
1	2	004111048	Nut, Hex, 3/8-16, SS
2	2	004156167	Nut, Acorn, Lock, Distorted Thread, 10-24, 18-8SS
3	2	004011054	Bolt, Carriage, Square Neck, 10-24 Thread, 3/4" Lg, 18-8SS
4	2	004405008	Screw, Set, Cup Point, 3/8-16 X 1-1/4" Lg, 18-8SS
5	2	004156074	Nut, Hex, S/L, Light, 3/8-16, 304SS
6	2	004011056	Bolt, Carriage, Square Neck, 3/8" Thread, 1-3/4" Lg, 18-8SS
7	2	004605034	Spacer, 1/2"x 1/4" Lg, for #10 Screw, 18-8SS
8	2	004816086	Washer, Flat, 3/8", 7/8" Diameter, SS
9	1	06010207	Reservoir Slide Base
10	2	06010386	Splash Shield, Slide, Round, SS
11	1	06010329	Fruit Guide Kit, Small Fruit
11a	1	06010328	Small Fruit Pin, Black, Plastic
11b	1	004220037	Retaining Pin, Stainless Steel
12	2	06010393	Reservoir Slide, Bushing
13	1	06010391	Guide, Slide, Reservoir, Left, SS
13a	1	06010392	Guide, Slide, Reservoir, Right, SS

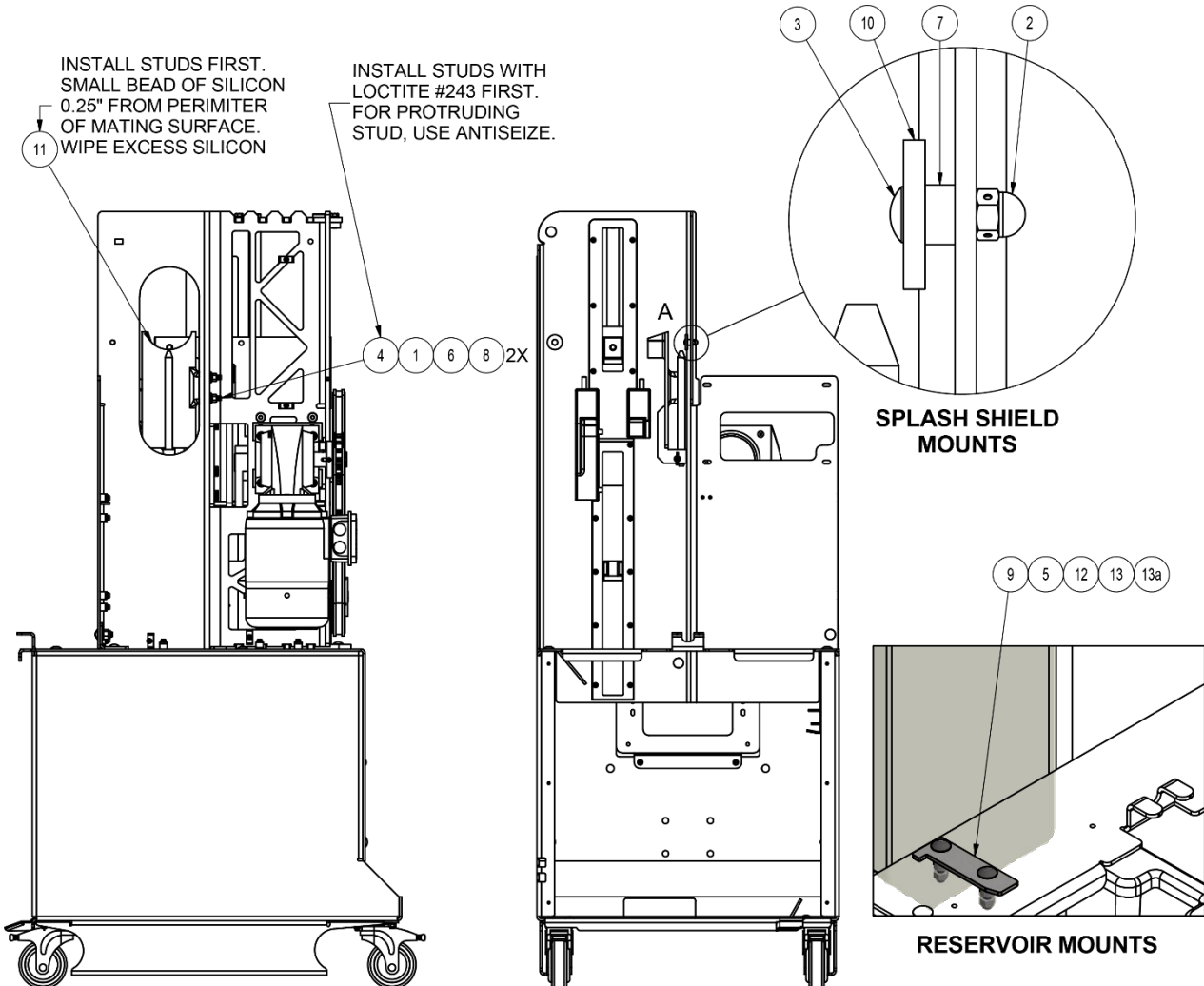

Figure 45. Splash Shield Guides, Fruit Guides

18. Fruit Lift, Hopper Mounting

<u>Item</u>	<u>Qty</u>	<u>Part Number</u>	<u>Description</u>
1	5	004352395	Screw, Cap, Hex, 3/8" X 1" Lg, SS
2	2	004352410	Screw, Cap, Hex, 3/8-16 X 2-1/4" Lg, 304SS
3	2	004356104	Screw, Cap, Hex, Socket Head, 3/8-16 X 1" Lg, 316SS
4	52	004401023	Screw, Phillips Head, Extra Wide, 8-32 Threaded, SS
5	1	004605029	Standoff, Hex, 5/8" X 1-2/3" Lg, 18-8SS
6	4	004816080	Washer, Plain, 3/8" N, 304SS
7	15	004816086	Washer, Flat, 3/8", 7/8" Diameter, SS
8	1	06010240	Fruit Lift, Mount Block
9	1	06010243	Mount, Hopper, Bolt

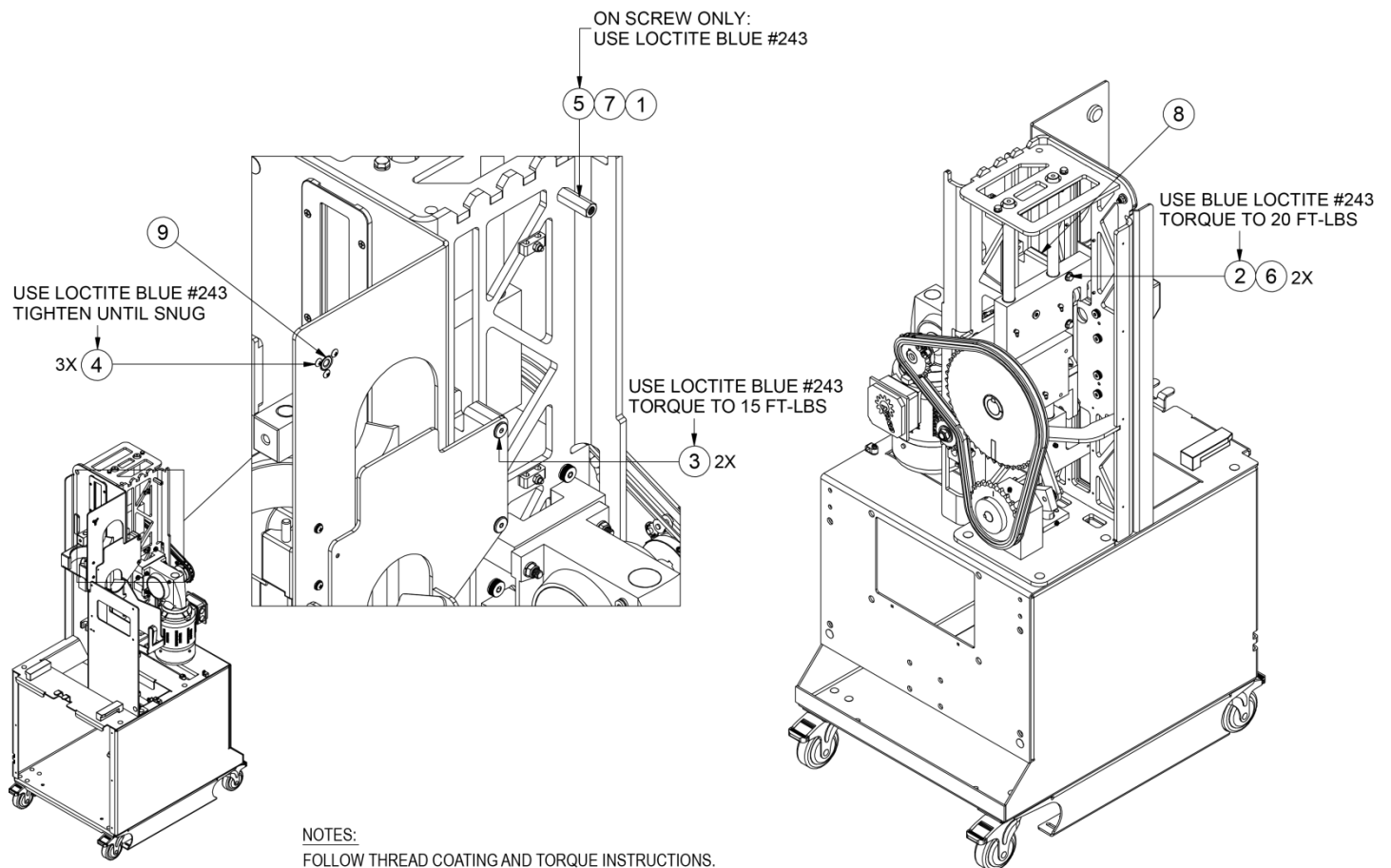
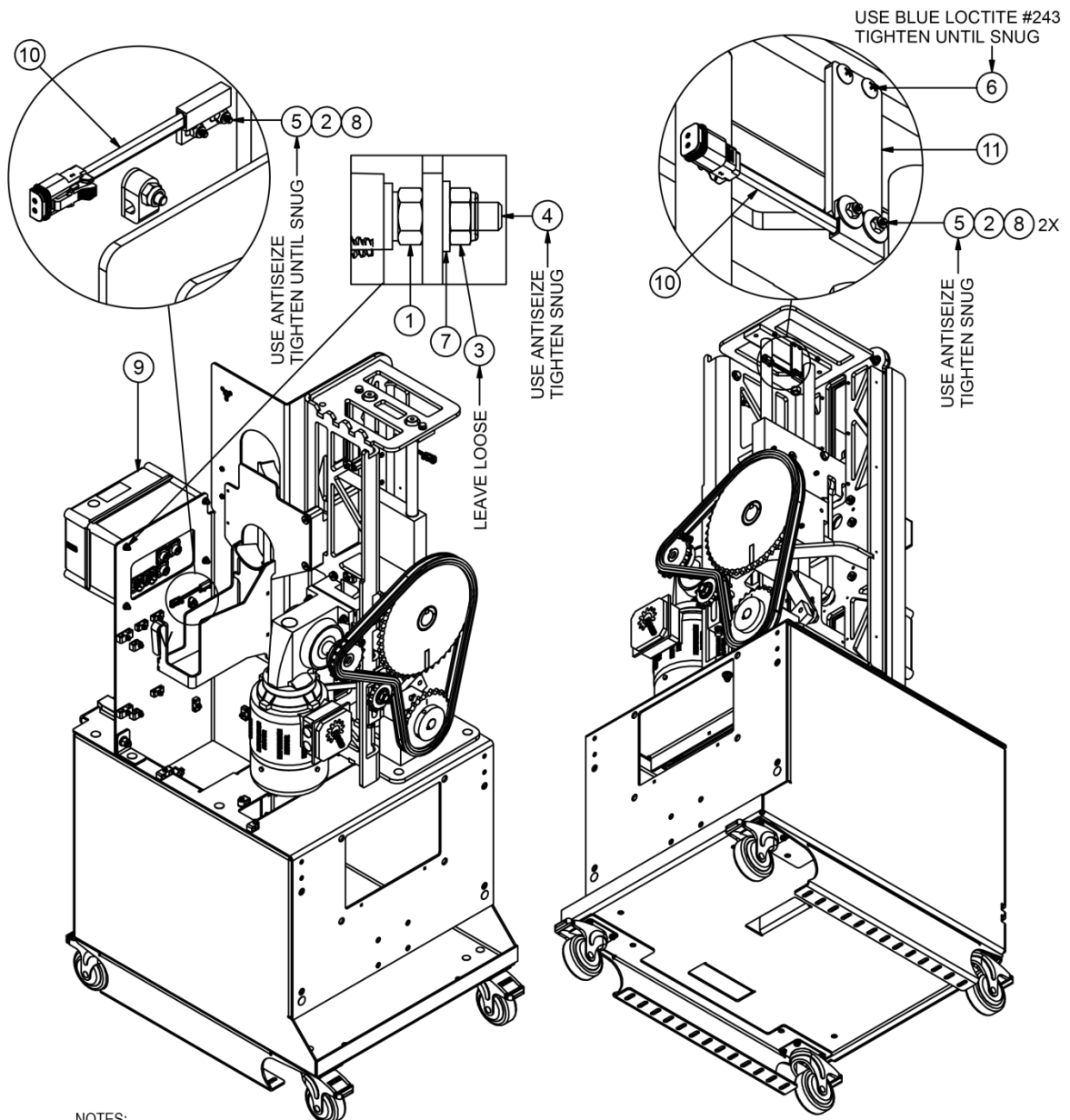

Figure 46. Fruit Lift, Hopper Mounting

19. HMI Mounting, Proximity Sensors for Float and TDC

Item	Qty	Part Number	Description
1	4	004011032	Nut, Hex, 1/4-20, SS
2	4	004156014	Nut, Hex, S/L, 4-40, SS
3	4	004156053	Nut, Hex, S/L, Light, Thin, 1/4-20, 304SS
4	4	004356064	Screw, Cap, Socket Head, 1/4-20 X 1-1/4" Lg, SS
5	4	004396116	Screw, Round, Bind, Slot, Extra Wide, 4-40 Threaded, 5/8" Lg, SS
6	52	004401023	Screw, Phillips, Extra Wide, 8-32 Threaded, 1/4" Lg, SS
7	4	004816060	Washer, Plain, 1/4" N, SS
8	6	004816095	Washer, #6, .149" ID, .625" OD, Oversized, 304SS
9	1	06010118	Electrical Panel Assembly
10	2	06010305	Proximity Switch Assembly, Normally Open Connection
11	1	06010306	TDC Sensor Bracket



NOTES:
FOLLOW ALL THREAD COATING AND TORQUE INSTRUCTIONS.

Figure 47. HMI Mounting, Proximity Sensors for Float and TDC

20. Electrical Connections

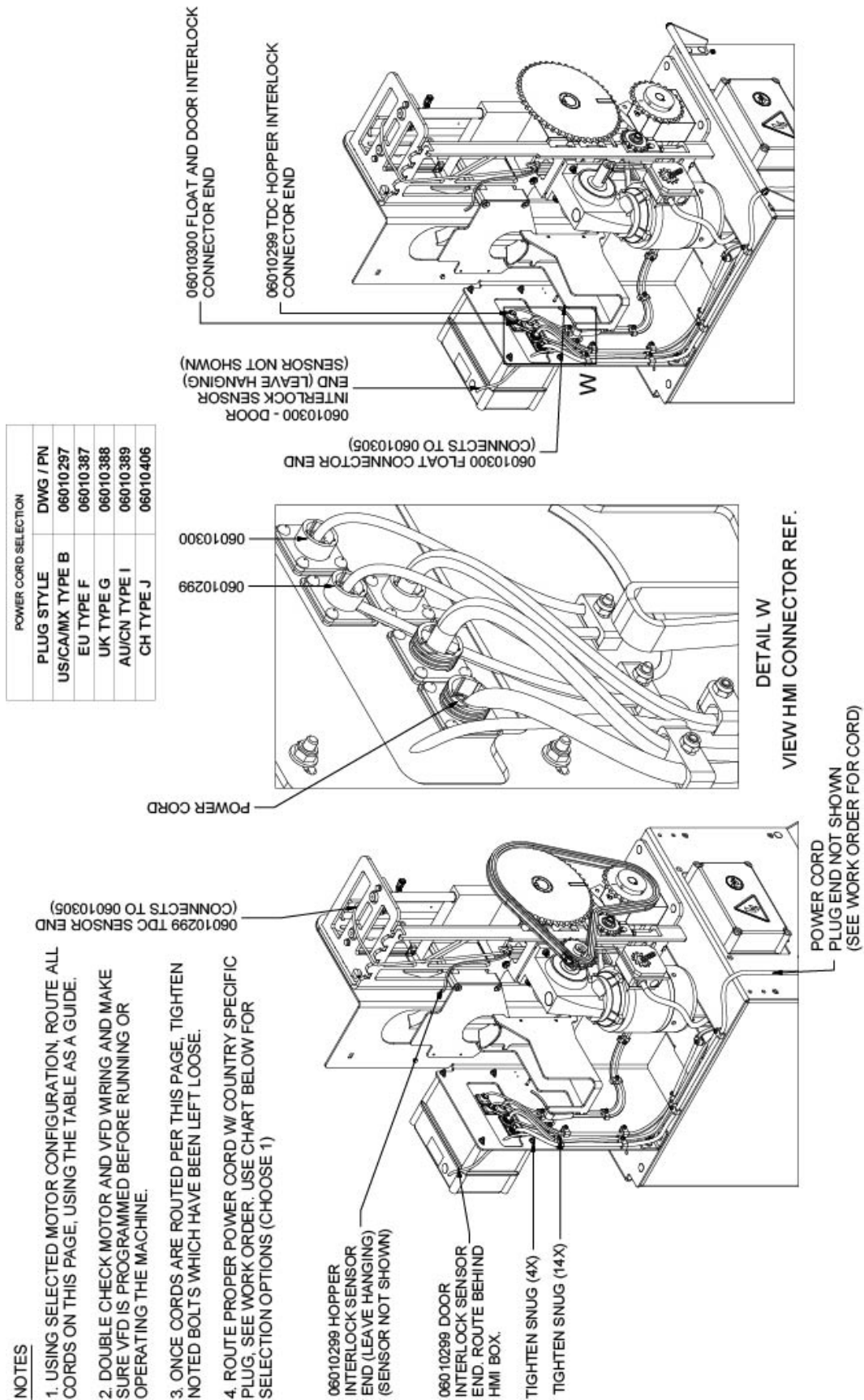

Figure 48. Electrical Connections

20. Electrical Connections (continued)

<u>Item</u>	<u>Qty</u>	<u>Part Number</u>	<u>Description</u>
1	1	06010484	Mount, Switch, Door and Spout, Self Serv MFJ
2	1	06010299	Cord Assembly, TDC and Hopper Interlock
3	4	004156168	Nut, Acorn, Lock, Distorted Thread, 10-32, 18-8, SS
4	4	004392212	Screw, Machine, Pan, #10-32 X 3/8", 304SS, Spanner
5	6	004816052	Washer, Plain, #10, SS
6	1	06010305	Proximity Switch Assembly. Normally Open Connection
7	2	004392166	Screw, Machine, Pan, Phillips, 4-40 X 3/8" Lg, SS
8	4	004156014	Nut, Hex, S/L, 4-40, SS
9	6	004605037	Spacer, Unthreaded, 5/16" OD X 3/16" Lg, Nylon
10	2	004156032	Nut, Hex, S/L, LT, 8-32, 304SS
11	2	004392197	Screw, Machine, Pan Head, Spanner Type, #8-32 X 1" Lg, SS

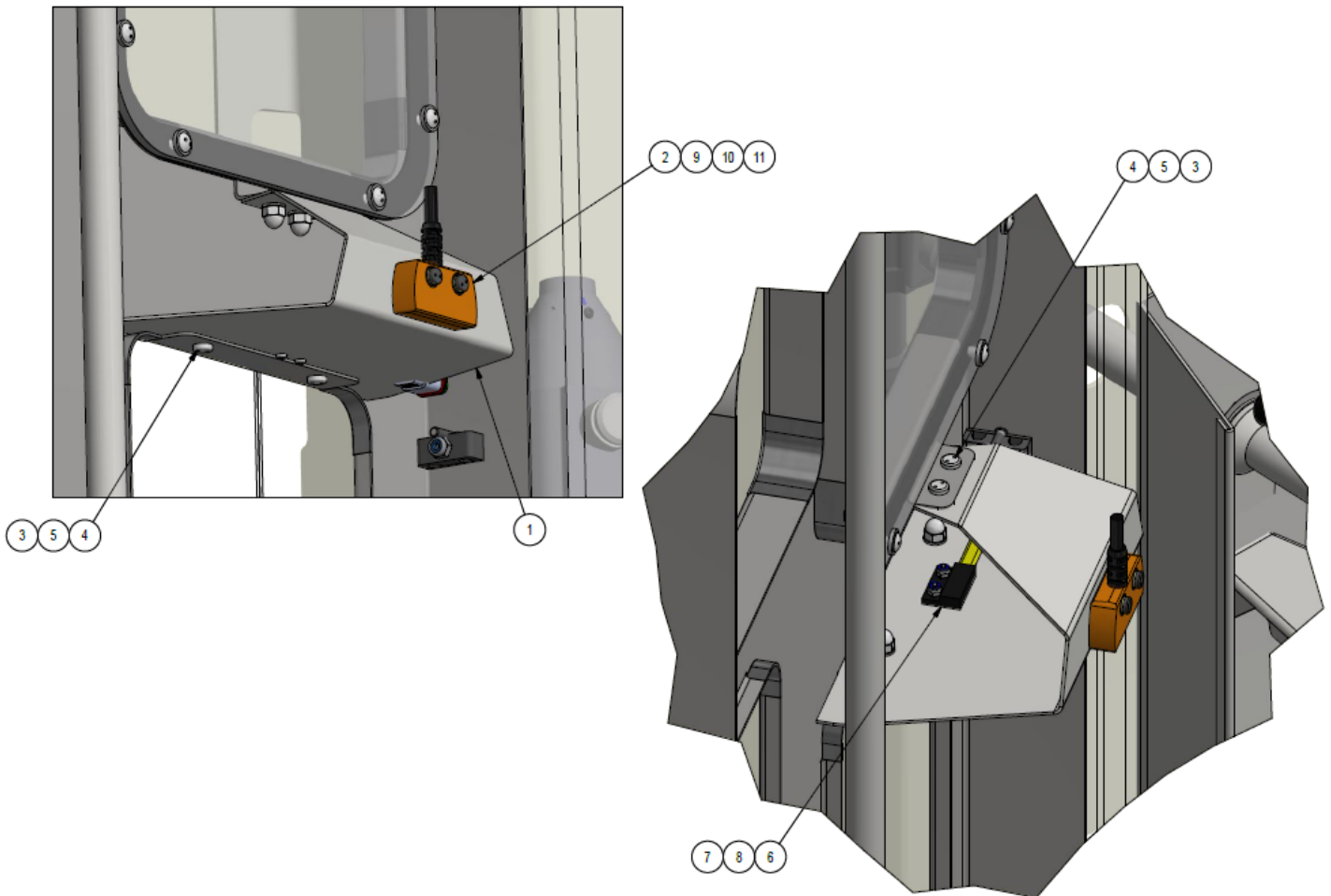
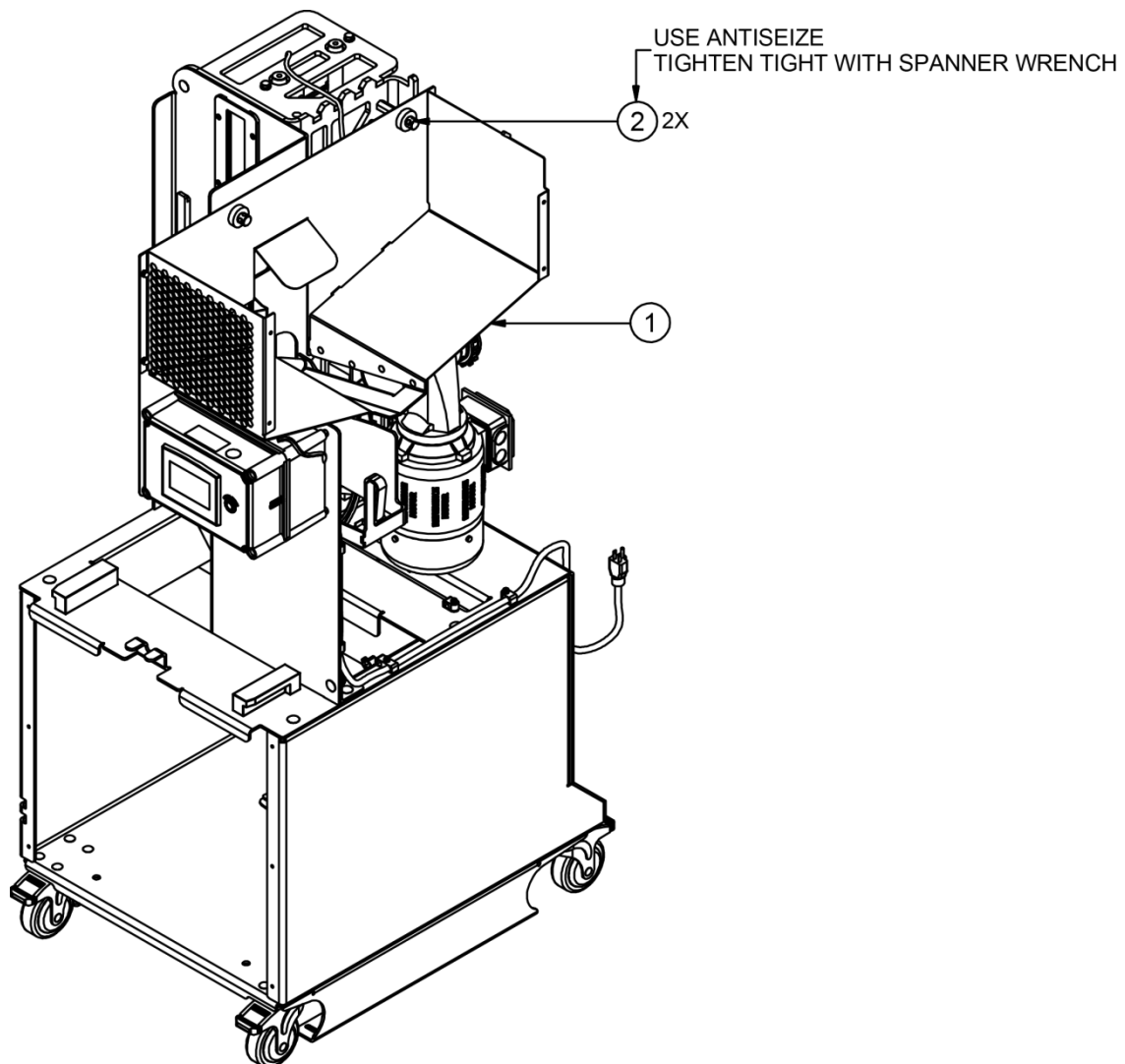

Figure 49. Electrical Connections, Switches

21. Hopper

<u>Item</u>	<u>Qty</u>	<u>Part Number</u>	<u>Description</u>
1	1	06010162	Hopper Assembly
2	2	06010254	Screw, Spanner, Hopper



NOTES:
FOLLOW ALL THREAD COATING AND TORQUE INSTRUCTIONS.

Figure 50. Hopper



22. Hopper Top Cover, Lid and Sensors

Item	Qty	Part Number	Description
1	6	004156032	Nut, Hex, S/L, Light, 8-32, 304SS
2	8	004385178	Screw, Span, Flat, 8-32 Threaded, 3/4" Lg, 18-8SS
3	52	004401023	Screw, Phillips, Extra Wide, 8-32 Threaded, 1/4" Lg, SS
4	1	006090018	Plug, Knockout, 7/8" ID Hole, Gray Nylon
5	2	009080421	Rubber Push-In Bumper with Tight-Grip Stem
6	2	009284961	Torque Hinge, Concealed, SS

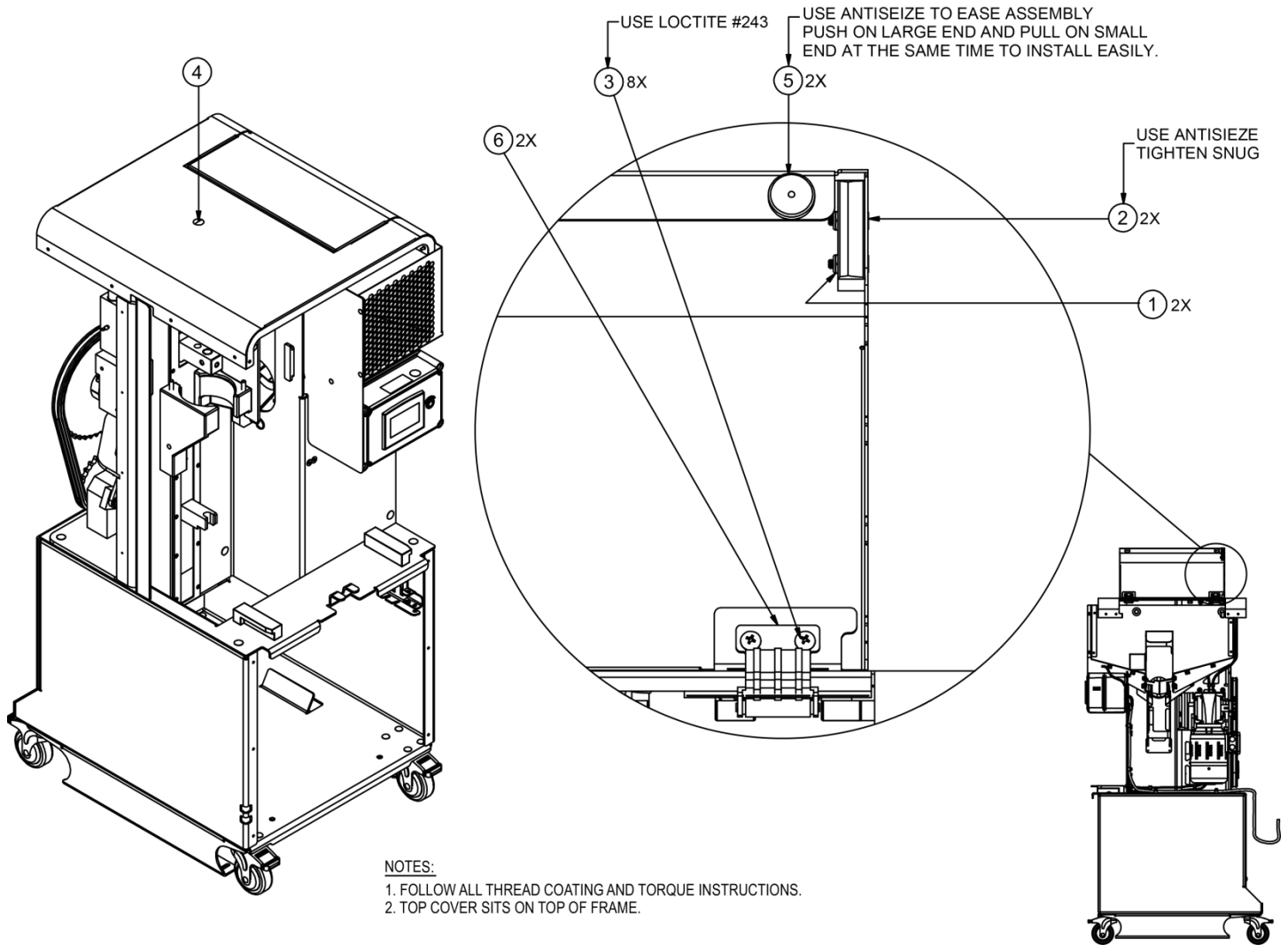
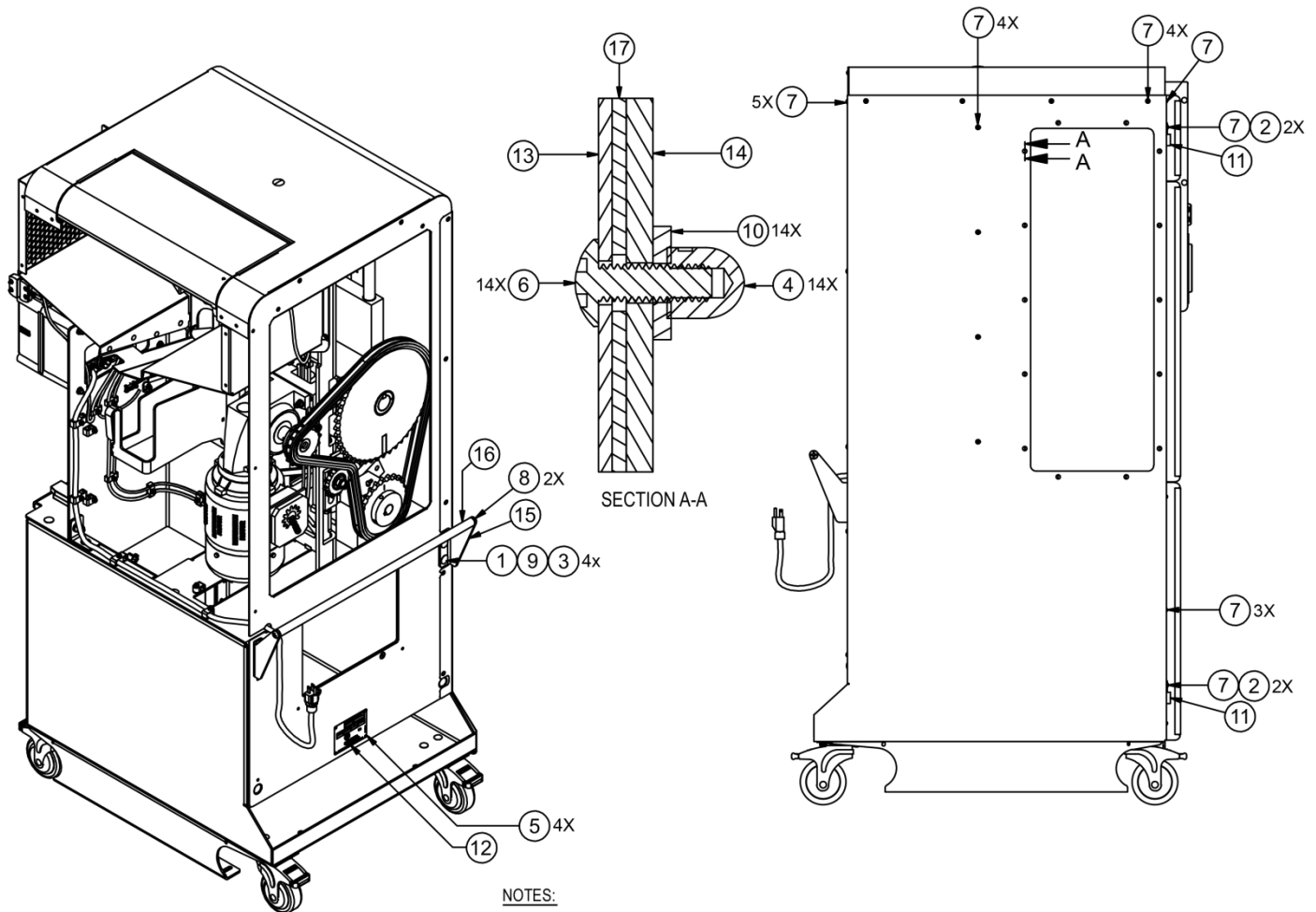

Figure 51. Hopper Top Cover, Lid and Sensors

23. Panels, Left and Rear

Item	Qty	Part Number	Description
1	12	004011032	Bolt, Carriage, 3/8-16 X 1-1/4" Lg, 304SS
2	4	004100004	Nut, Cap, Acorn, High Crown, #8-32, SS
3	4	004100018	Nut, Cap, Acorn, 3/8-16, SS
4	14	004156166	Nut, Acorn, Lock, Distorted Thread, 8-32. 18-8SS
5	4	004260017	Rivet, Pop, 1/8", SS
6	14	004385174	Screw, Round, Drilled Spanner, Extra Wide, 8-32 X 1/2", SS
7	52	004401023	Screw, Phillips Head, Extra Wide, #8-32 Threaded, SS
8	2	004510107	Screw, Button Head, 3/8-16 X 1" Lg, Philips, 18-8SS
9	15	004816086	Washer, Flat, 3/8", SS
10	14	004816105	Washer, Oversized, #8, 18-8SS
11	2	009284050	Female Hinge
12	1	01503948	Name Plate
13	1	06006311	Side Cover, LH
14	1	06006312	Glass, LH Side
15	1	06010179	Bracket, Handle, Right
16	1	06010180	Handle, MFJ Cart
17	1	06010209	Gasket, Window



NOTES:

1. COAT ALL THREADS AND RECEIVING THREADS WITH A THIN LAYER OF ANTISEIZE.
2. RIVET ON SERIAL NUMBER PLATES USING RIVETS.
3. ENGRAVE SERIAL AND OTHER APPLICABLE IDENTIFICATION DIGITS.

Figure 52. Panels, Left and Rear



24. Service Panel, Right Panel

Item	Qty	Part Number	Description
1	6	004156032	Nut, Hex, S/L, Light, 8-32, 304SS
2	4	004385178	Screw, Span, Flat, 8-32 Threaded, 3/4" Lg, 18-8SS
3	2	004392175	Screw, Machine, Pan, 8-32 X 3/4" Lg, 304SS
4	52	004401023	Screw, Phillips, Pan, Extra Wide, 8-32 Threaded, 1/4" Lg, SS
5	1	06010349	Cover Assembly, RH Side
6	1	06010523	Stirrer Knob Assembly
7	1	06006303	Service Panel
8	2	004385173	Safety Screw

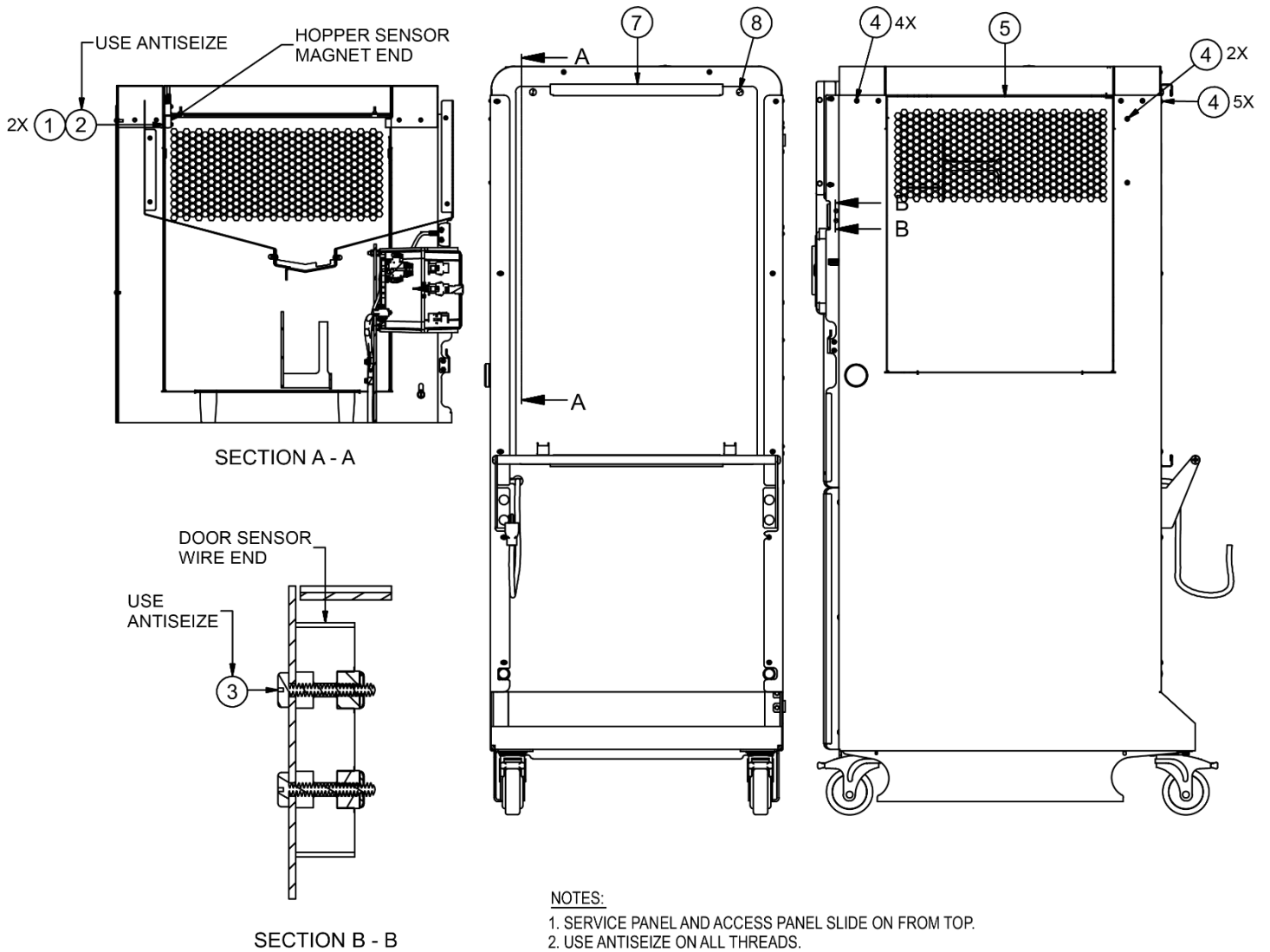

Figure 53. Service Panel, Right Panel

25. Decals (Standard)

Item	Qty	Part Number	Description
1	1	009450032	Decal, Fresh N' Squeeze Logo
2	1	009450040	Decal, Cleaning Components
3	1	06000104	Decal, Warning Label, Sheer/Hand Crush, English/Spanish

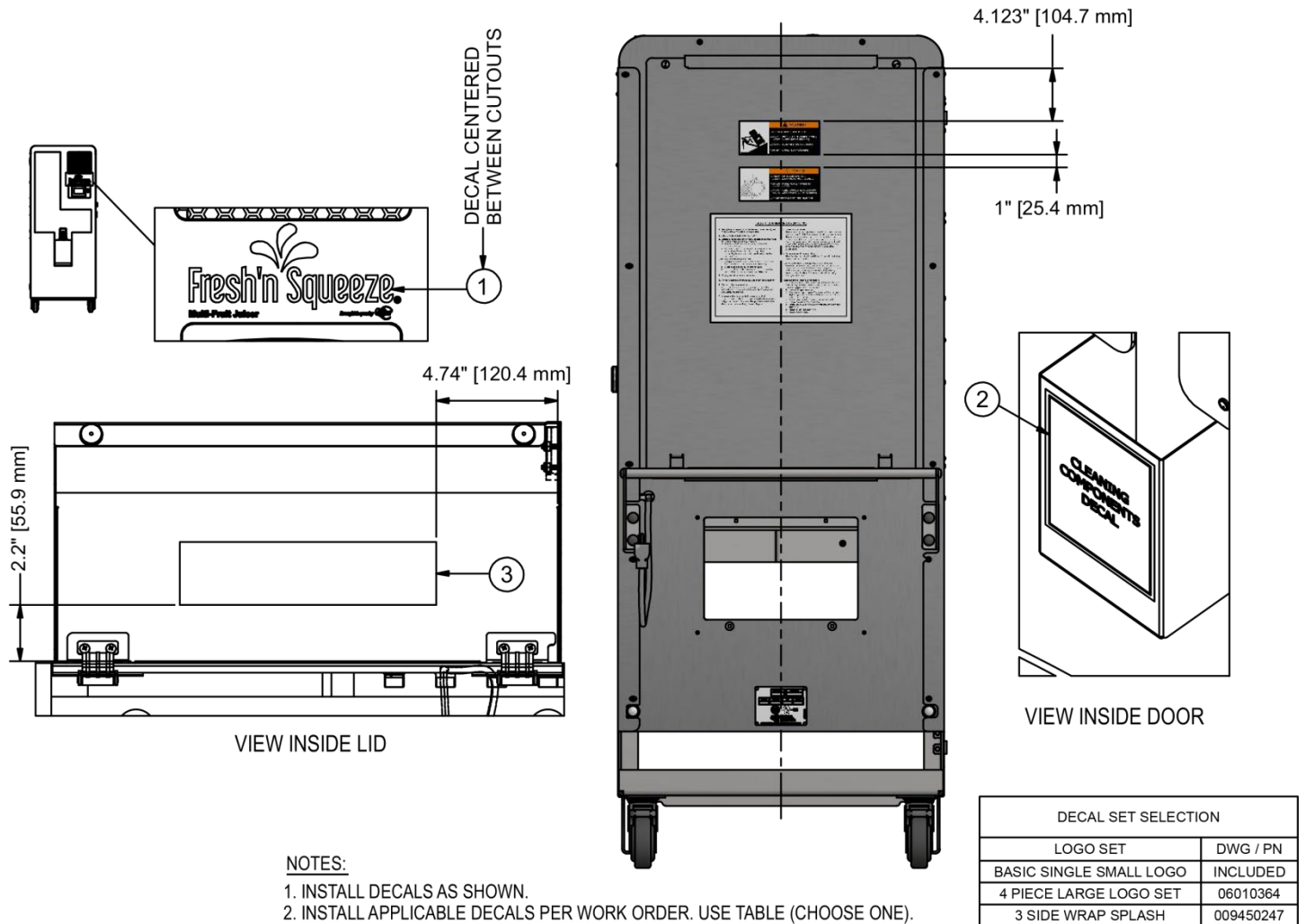
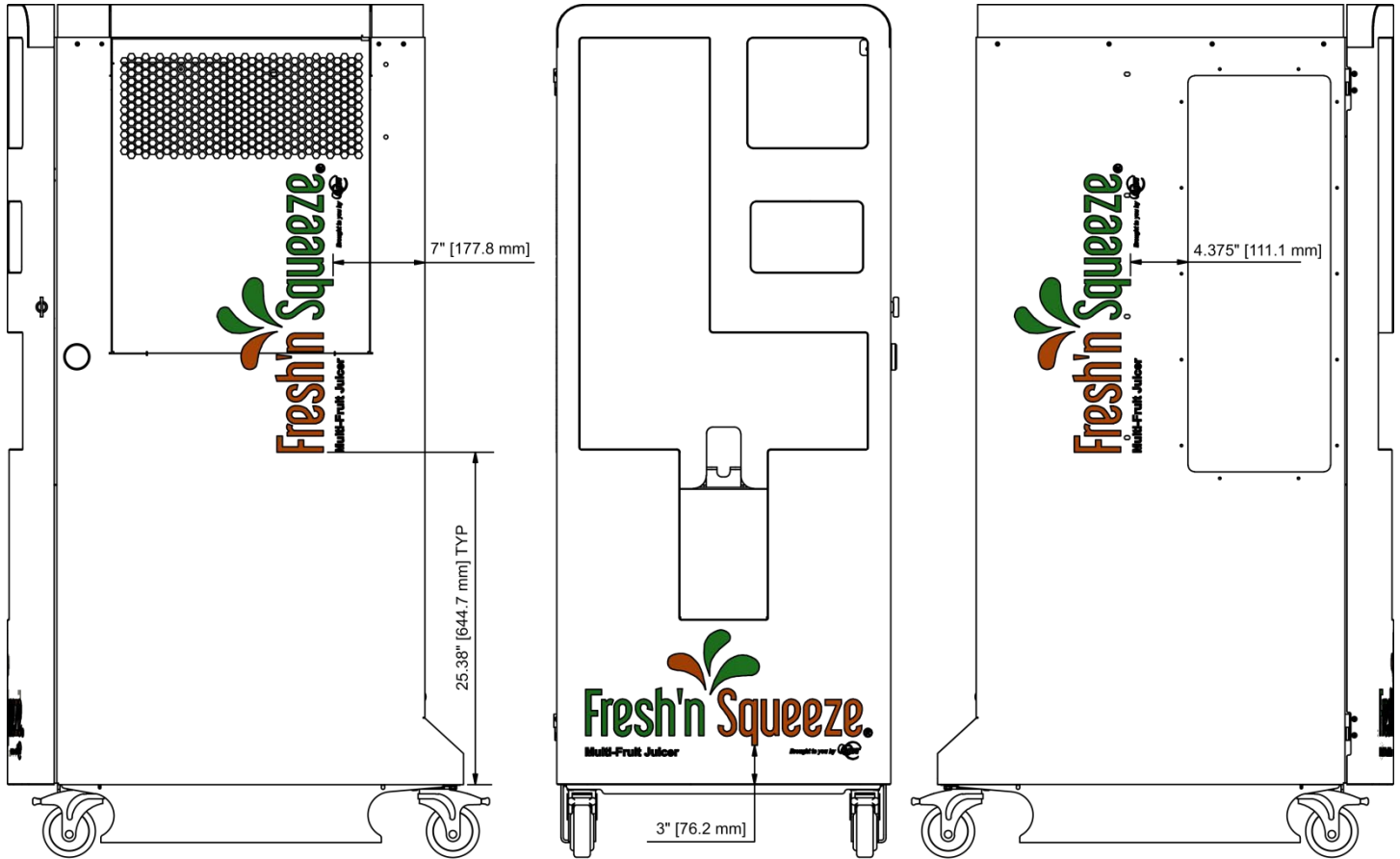

Figure 54. Decals (Standard)



26. Decals, 3-Piece, Large Logo (Optional)

Item	Qty	Part Number	Description
1	3	009450245	Decal, MFJ, Logo, Fresh 'N Squeeze, 10.25" X 22", Matte, Vinyl



NOTES:

1. CLEAN SURFACES WITH ALCOHOL BEFORE APPLYING DECALS.

Figure 55. Decals, 3-Piece, Large Logo (Optional)

27. Juicing Components

Item	Qty	Part Number	Description
1	1	004220037	Pin, Quick Release, Ring Grip
2	1	004406003	Screw, Machine, Round, #4-40 X 3/16" Lg, 304SS
3	1	06000004	Cup, Lower, Machined
4	1	06000022	Nozzle, Straight, FDA Grade
5	1	06000027	Cup, Upper, Assembly
6	1	06000225	Cutter and Knives with Item #2 Screw
7	2	06000098	Nut, Spanner
8	1	06000108	Manifold, Juice
9	1	06010073	Screw, Spanner
10	1	06010143	Tube, Orifice, Snap In
11	1	007486119	O-Ring, Nozzle, Viton, 1/16" Section

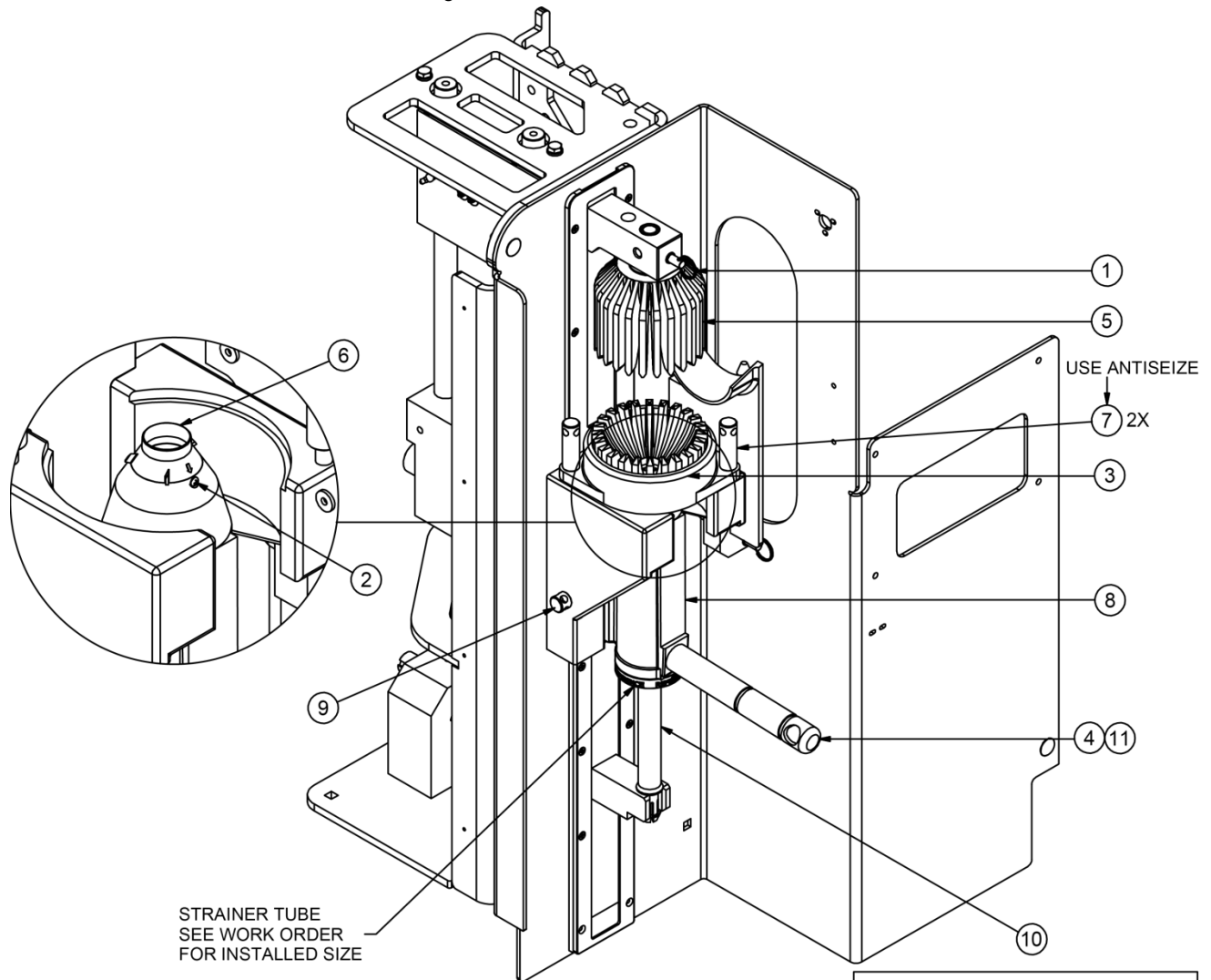

NOTES:

- NEVER PLACE HANDS IN BETWEEN CUPS.
- CHECK CLEARANCE WHEN CUP MOVES UP AND DOWN, DO NOT PLACE HANDS IN BETWEEN CUPS WHILE DOING SO.
- ENSURE CUPS MESH WITH NO MAJOR ALIGNMENT ISSUES BEFORE PROCEEDING.
- USE APPROPRIATE STRAINER TUBE PER WORK ORDER. USE TABLE (CHOOSE ONE).

STRAINER TUBE SELECTION	
STRAINER TUBE SIZE	DWG / PN
0.028"	06000289
0.033"	06000086
0.040"	06000208
0.055"	06000230

Figure 56. Juicing Components

28. Self-Service Specific Juicing Components

<u>Item</u>	<u>Qty</u>	<u>Part Number</u>	<u>Description</u>
1	1	06010494	Handle Momentary
1a	1	06010495	Handle Continuous
2	1	06010485	Spout Cap
3	1	06010482	Spout Body
4	1	06010479	Self-Service Housing
5	1	06010442	Manifold with Vent
6	1	06010429	Drip Tray Cover
7	1	009210043	Seat Cup
8	1	009210042	Stem
9	1	009210041	Spring
10	1	007486119	O-Ring Nozzle

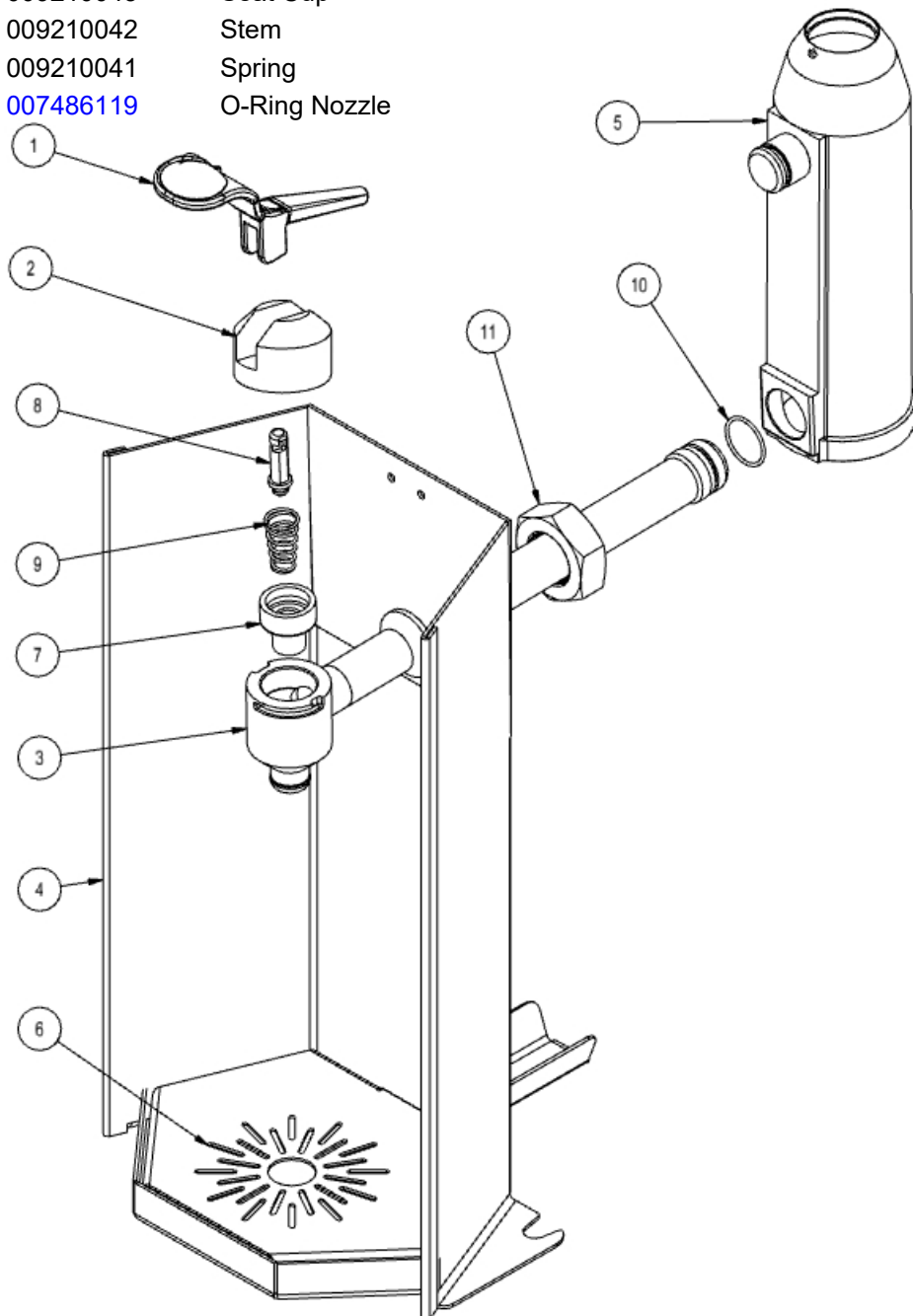
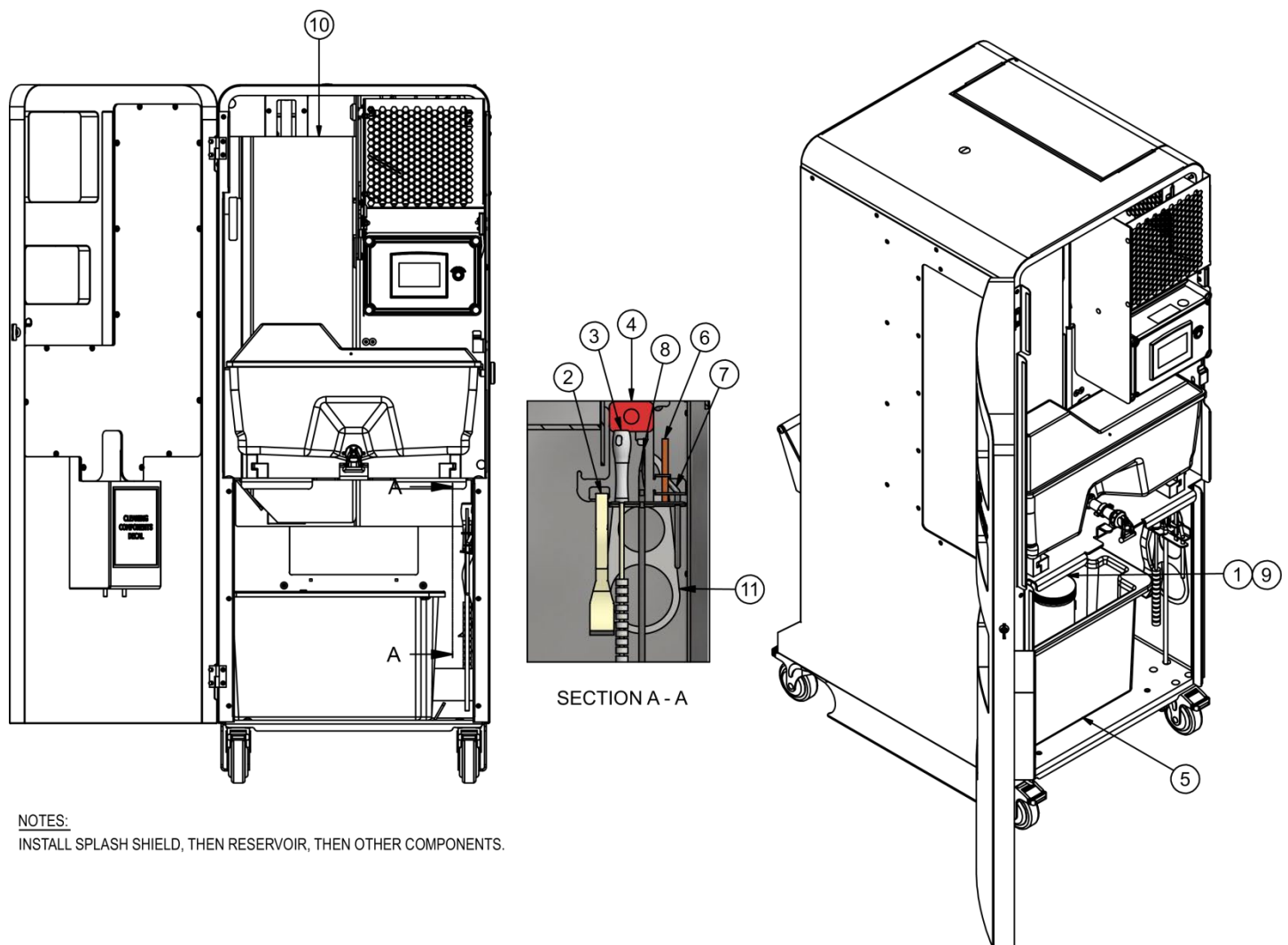

Figure 57. Splash Shield, Waste Bin, Tools and Accessories

29. Splash Shield, Waste Bin, Tools and Accessories

<u>Item</u>	<u>Qty</u>	<u>Part Number</u>	<u>Description</u>
1	1	003091001-2	Cleaner, Corklean, 2 lbs
2	1	009080327	Brush, Dish
3	1	009080328	Brush, Tube, 1"
4	1	009092018	Cap, Cover
5	1	009092023	Waste Container, 21" X 17" X 12", Polyethylene, Grey
6	1	009710031	Stone, Sharpening, Half Round
7	1	06000077	Tool, Wrench, 5/16" Diameter
8	1	06000084	Rod, Orifice Clean Out
9	1	06001127	Cleaning Component Kit, Spray Pump with Wide Mouth Bottle and Scoops
9a	1	06001128	Cleaning Component Kit, Spray Pump with Wide Mouth Bottle Only
10	1	06010188	Splash Shield
11	1	06010359	Triple Fruit Sizer, Hand-Held



NOTES:
INSTALL SPLASH SHIELD, THEN RESERVOIR, THEN OTHER COMPONENTS.

Figure 58. Splash Shield, Waste Bin, Tools and Accessories

30. Reservoir and Components

<u>Item</u>	<u>Qty</u>	<u>Part Number</u>	<u>Description</u>
1	1	009210032	Faucet, Front Handle, Threaded, Black Nylon
2	1	009998005	Shank, Round, 1/2-14 Npsm Threads, Black Nylon
3	1	06000025	Lid, Reservoir
4	1	06010266	Stirrer, Reservoir Knob Type
5	1	06010310	Reservoir, Bottom
6	1	06010522	Magnet
7	1	06010525	Float
8	1	06000137	Frame, Float Pivot

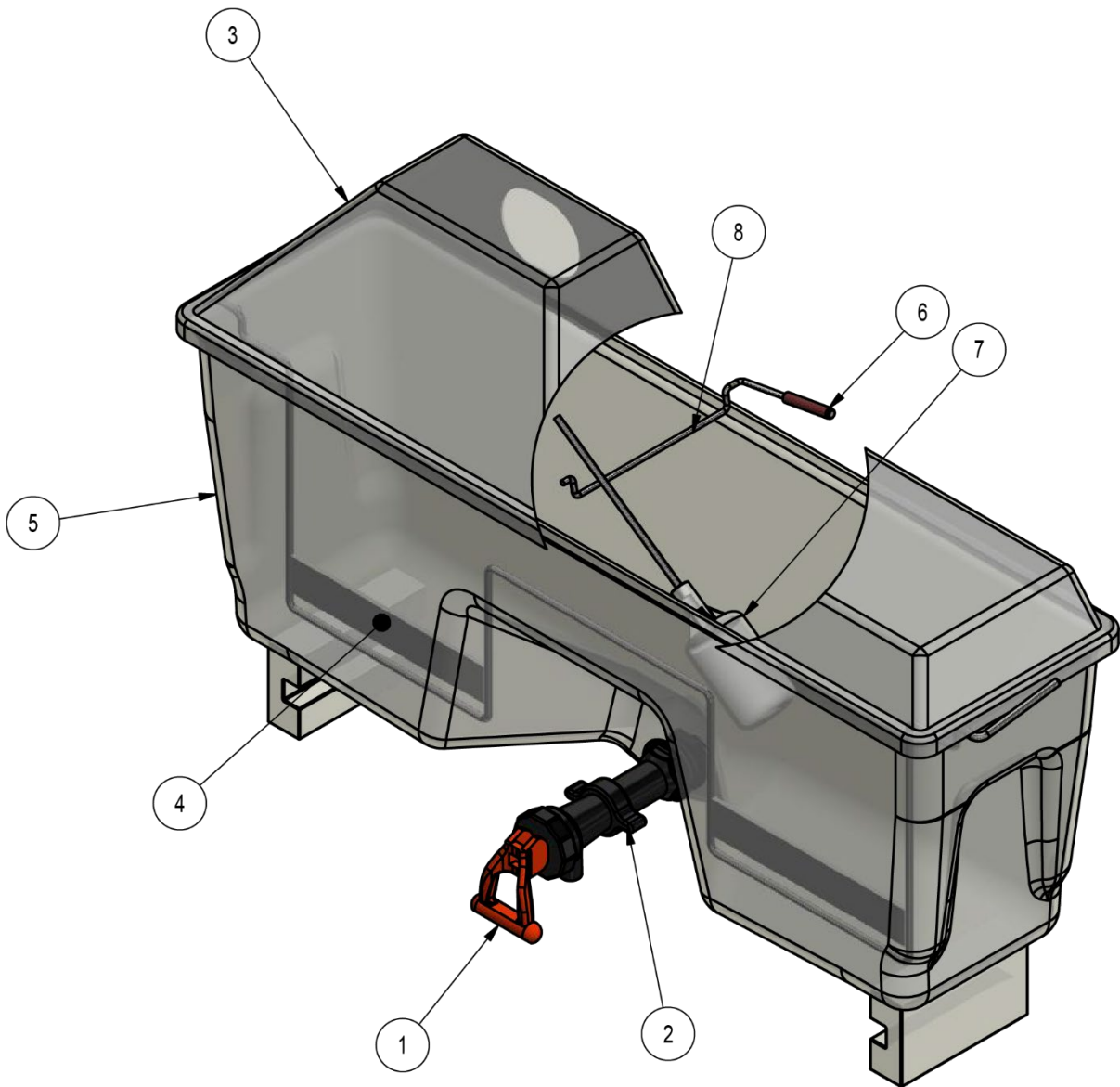
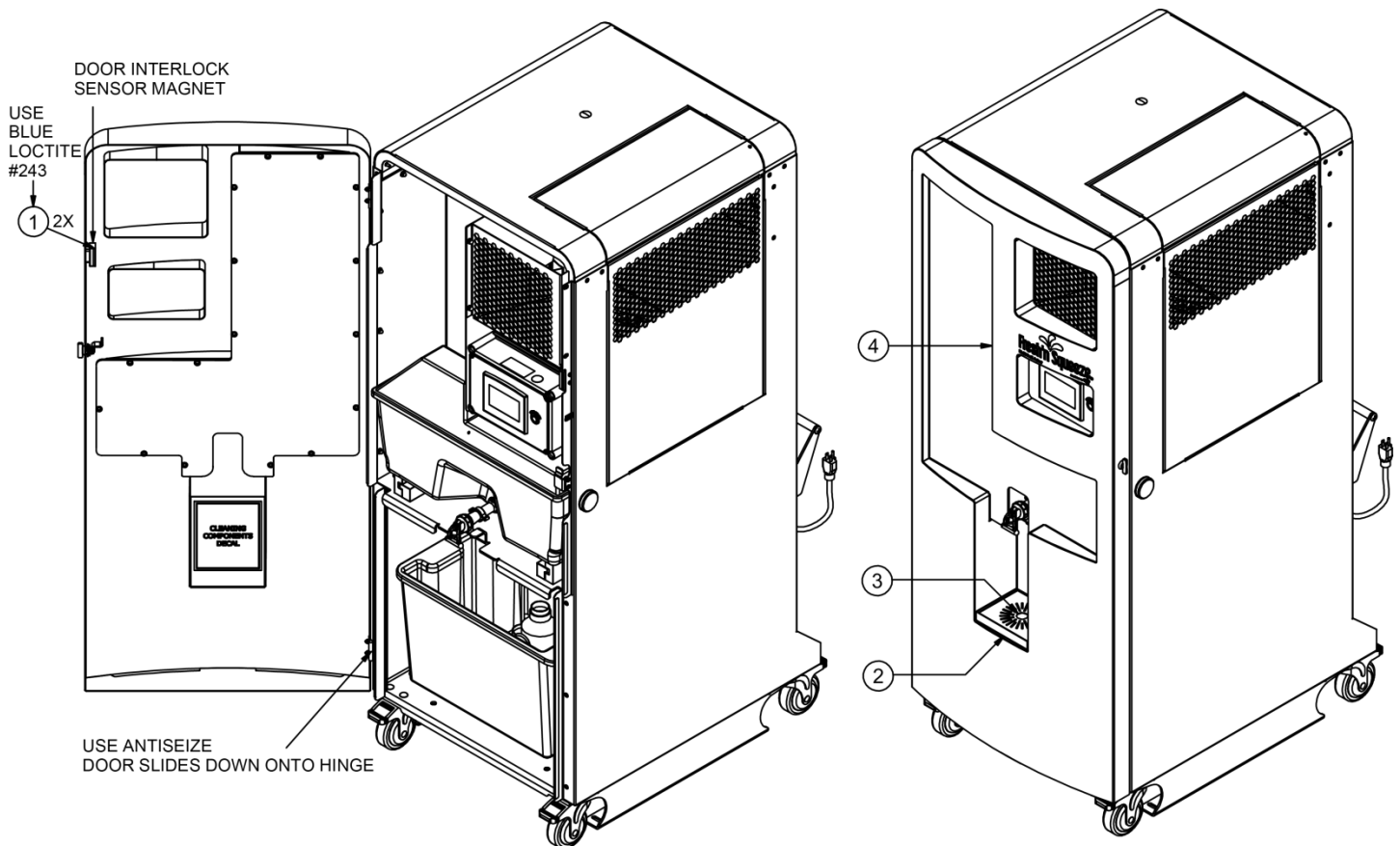

Figure 59. Reservoir and Components

31. Door, Latches and Hinges

Item	Qty	Part Number	Description
1	2	004385176	Screw, Span, Pan, 8-32 Threaded, 5/8" Lg, 18-8SS
2	1	06010146	Drip Tray Weldment
3	1	06010147	Drip Tray Cover
4	1	06010315	Door Assembly
4a	1	06010411	Self Service Door Assembly
5	1	06010516	Window and Gasket Kit Reservoir Door
5a	1	06010517	Window and Gasket Kit Self Service Door



NOTES:

1. ADJUST LATCH FOR LOCK SUCH THAT WHEN DOOR IS SHUT, LIGHT OR NO PRESSURE ALLOWS LATCH TO CLOSE AND DOES NOT RATTLE WHEN CLOSED.
2. FOLLOW LABELED THREAD COATING AND TORQUE INSTRUCTIONS.
3. COAT DRIVE CHAIN WITH GREASE.
4. CHECK CART BOLTS, WIRE ROUTING BOLTS AND OTHER BOLTED CONNECTIONS AND ENSURE THEY ARE TIGHT.

Figure 60. Door, Latches and Hinges



32. Auto Lubrication Parts (Optional)

Item	Qty	Part Number	Description
1	5	06010456	Fitting Adapter, Modified, 1/4" GX X 1/4-28
2	1	06010452	Lubricator Bracket
3	1	007130811	Elbow, 90 Degree, Street, 1/4" BSP, 304SS, 150#
4	2	004816052	Washer, Plain, #10
5	1	004401030	Screw, Machine TRS, 10-24 X 3/4", SS
6	1	004156041	Nut, Hex S/L, 10-24, SS
7	1	003460093	Lubricator Brush, Clamp, Round
8	1	003460092	Lubricator Brush, Round, 1/4" BSP Female
9	6	003460091	Lubrication, Dispenser, 60 ML, 1/4" BSP Male

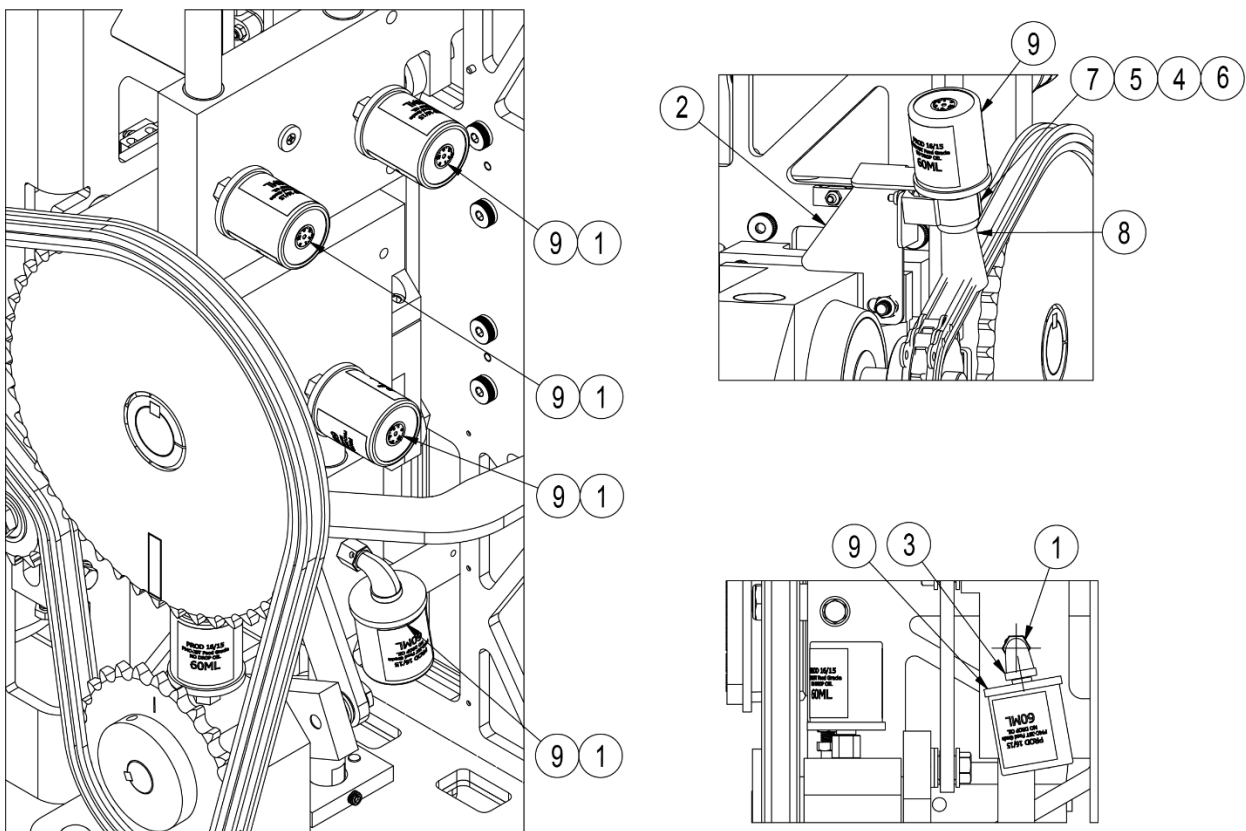

NOTES:

WHEN REPLACING LUBRICATION DISPENSERS, PREPARE AND CALIBRATE PRIOR TO INSTALLING.
 IF PRODUCTION IS LESS THAN 50 GALLONS OR 200 LITERS PER DAY, SET THE INTERVAL TO 12 MONTHS.
 IF PRODUCTION IS GREATER, SET THE INTERVAL TO 6 MONTHS.



DO NOT REMOVE PLUG FROM OIL FILLED UNITS!
 CUT OFF THE PROTRUDING NIPPLE WITH A KNIFE; A SMALL BLACK POINT BECOMES VISIBLE (OPENING NOW GUARANTEED).



TO START THE SIMALUBE LUBRICATOR, SET THE GAS GENERATOR TO THE REQUIRED DISPENSING TIME (STEPLESS IN MONTHS, 1-12) USING A 3 MM ALLEN KEY.
 THE LUBRICATOR IS ACTIVATED ONCE THE DISPENSING TIME HAS BEEN SET.

Figure 61. Auto Lubrication Parts

Electrical Drawings and Procedures

Electrical drawings in this chapter provide a list of part numbers for replaceable parts available for the 2nd Generation Multi-Fruit Juicer. The following parts list/drawings are provided:

Parts List / Parts Drawing	Page
33. Drive, Motor Wiring, 3-Phase, 230V/460V, 50 Hz/60 Hz, 06010357	80
34. VFD Enclosure Assembly, 06010366	81
35. Electrical Panel Assembly, 06010118	82
Wiring Schematic, Electrical Panel	86
Wire Table, Electrical Panel	88
36. Programming the VFD	89
37. Procedure to Check Safety Cable Assemblies	90
38. PLC Battery Replacement Procedure	96

33. Drive, Motor Wiring, 3-Phase, 230V/460V, 50 Hz/60 Hz, 06010357

Item	Qty	Part Number	Description
1	1	005617345	Gear Motor, Worm, 1.5 HP, 3 PH, 230V/460V, 50,Hz/60Hz, 1:25 Gear, 1.25 Shaft
2	1	06010366	VFD Enclosure Assembly

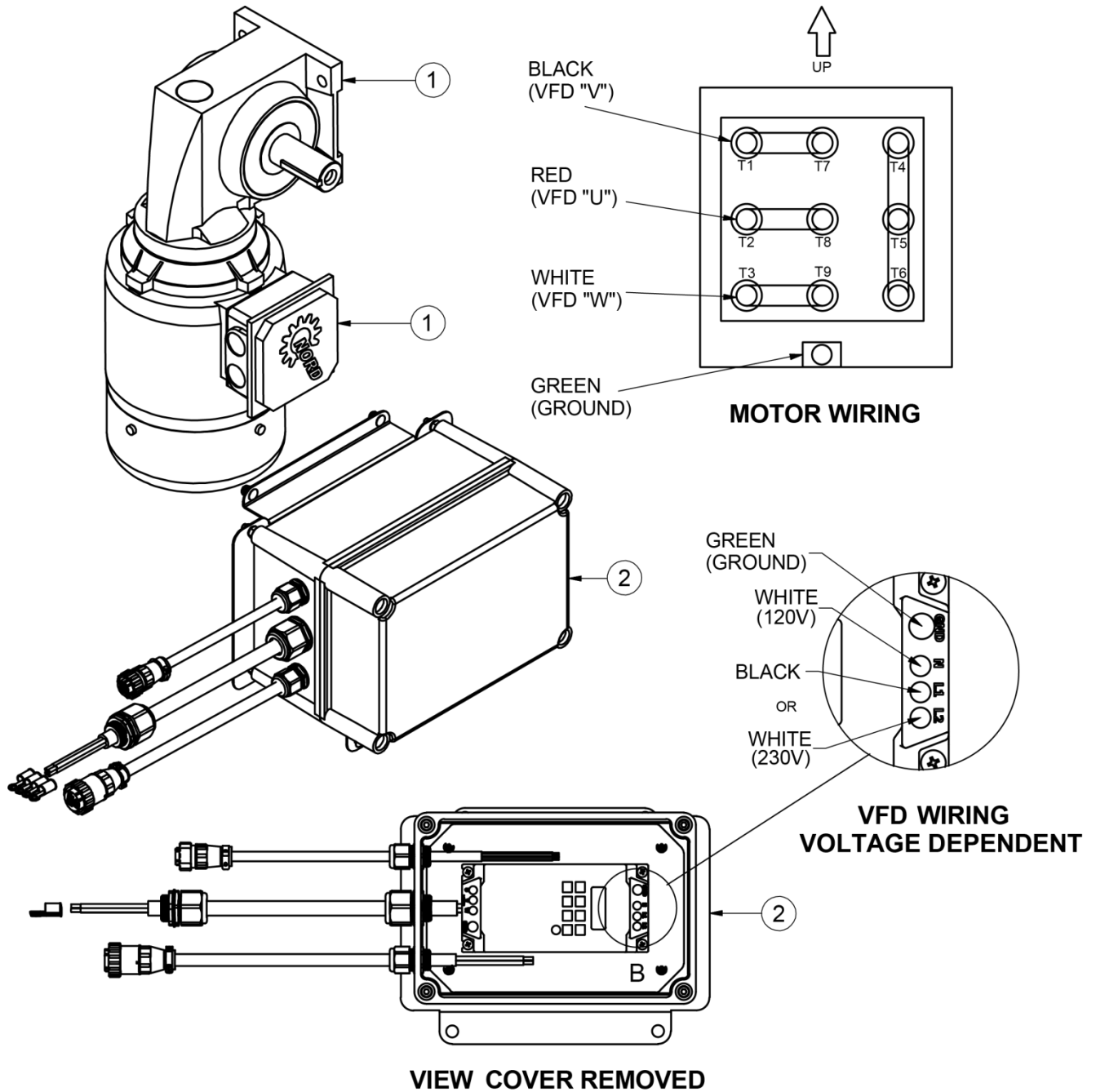

Figure 62. Drive, Motor Wiring, 3-Phase, 230V/460V, 50 Hz/60 Hz

34. VFD Enclosure Assembly, 06010366

Item	Qty	Part Number	Description
1	1	06010360	Enclosure, VFD, Add Holes
2	1	06010358	Back Panel, VFD
3	1	06010317	HMI-VFD Power Cord
4	1	06010316	VFD-Motor Power Cord
5	1	06010314	HMI-VFD Signal Cord
6	1	06010311	Rear Enclosure Bracket
7	1	006280536	VFD, 115/230V, 50Hz/60Hz, 1.5 HP-2 HP, UL
8	12	004816052	Washer, Plain, #10, SS
9	4	004401023	Screw, Phillips head, Extra Wide, 8-32" Threaded, 2/8" Lg
10	4	004356062	Screw, Cap Socket, 1/4-20 X 1: Lg, SS
11	8	004156042	Nut, Hex, S/L, Thin, 10-24, 304SS
12	4	004111032	Nut, Hex, 1/4-20, SS
13	4	004011051	Bolt, Carriage, 10-24 X 1/2" Lg, Square Neck, Full Thread, SS

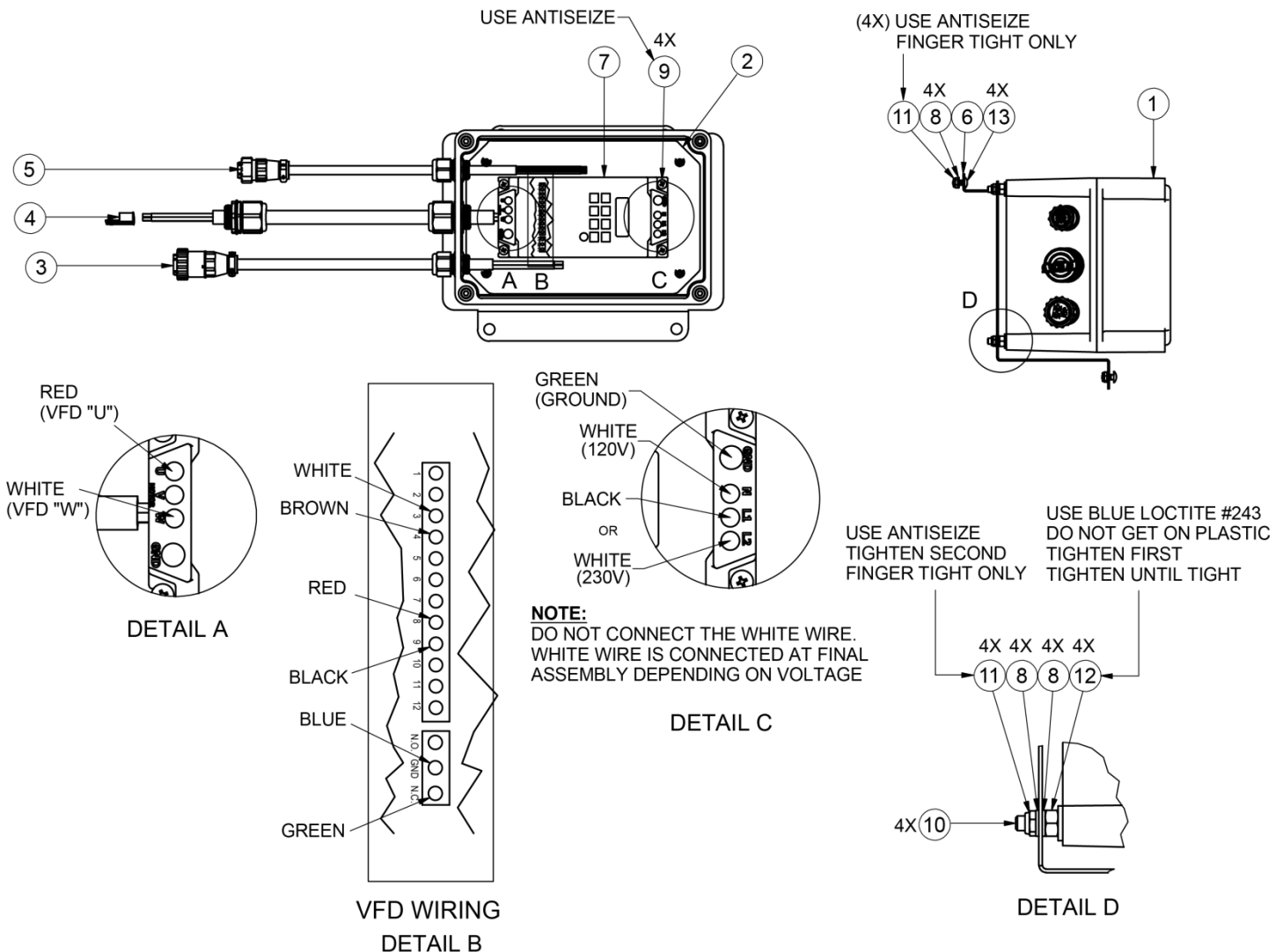

Figure 63. VFD Enclosure Assembly



35. Electrical Panel Assembly, 06010118

<u>Item</u>	<u>Qty</u>	<u>Part Number</u>	<u>Description</u>
1	3	003435022	Gasket, Flange, 0.862", Shell Size 13, Neoprene
2	2	003435023	Gasket, Flange, 1.1", Shell Size 17, Neoprene
3	20	004260007	Rivet, Blind, 1/8" Diameter X 7/16" Lg, SS
4	4	004397137	Screw, Machine, Round, 10-24 X 3/8" Lg, 304SS
5	20	Purchased	Rivet Washer
6	10	006010046	Strip, Terminal, Type UK5N
7	1	006010047	Din Rail, Perforated, 1.5" 89 mm (3.5")
8	1	006010047	Din Rail, Perforated, 1.5" 137 mm (5.4")
9	1	006010048	Barrier, End, Type D-UK 4/10
10	2	006010049	Bar, Jumper, FB1 10-6, (Jumps 10 Terminals)
11	1	006020076	Circuit Breaker, On/Off, Metal, 28V
12	1	006070033	Contactor, 12-600CAV, 50-60 Hz, 12-220 VDC
13	1	006070100	Connector, Housing, 9-Pole, Female Push In, Nylon, 11A
14	1	006070101	Connector, Housing, 9-Pole, Male Push In, Nylon, 11A
15	1	006070102	Connector, Housing, 6-Pole, Female Push In, Nylon, 11A
16	1	006070103	Connector, Housing, 6-Pole, Male Push In, Nylon, 11A
17	19	006070104	Connector, Push In, Female, 13.5A 20AWG-14AWG, Brass
18	19	006070105	Connector, Push In, Male, 13.5A 20AWG-14AWG, Brass
19	1	006070106	Connector, Male, Signal/Power, Push-In, 4-Pole, 14A
20	1	006070107	Connector, Female, Signal/Power, Push-In, 4-Pole, 14A
21	27	006080138	Connector Pin, Male, 20-24 GA, 13A, Plated Brass
22	1	006090376	Enclosure, Polycarbonate, 10.9" X 7.4" X 7.1", Insulated, Sealed
23	1	006160071	Relay, Overload, 12-16A
24	1	006160110	Relay, Din Rain Mount, 24V, 12mA, 6A Rating, 400 VAC
25	1	006160136	Safety Relay, Din Rail Mount, 24 VAC, 24 VDC
26	2	006210482	Terminal Block, Double Level, 26 AWG-12 AWG, 20A, 300V
27	2	006220044	Terminal, Q-Disc, Flame Retardant, 90 Degree, 12-10 AWG, Yellow
28	2	006221106	Terminal, Ground, Type USLKG25
29	2	006221179	Terminal Block, End Cover, Gray Plastic
30	3	006221180	End Stop, Din Rail 1, 3, Gray, IP20
31	1	006260041	Wire, Stranded, 22AWG, 300V, AC, Tin Plated, Black5
32	1	006260042	Wire, Stranded, 22AWG, 300V, AC, Tin Plated, Red
33	1	006260043	Wire, Stranded, 22AWG, 300V, AC, Tin Plated, Blue
34	1	006260044	Wire, Stranded, 22AWG, 300V, AC, Tin Plated, Brown
35	1	006260045	Wire, Stranded, 12AWG, 300V, AC, Tin Plated, Black
36	1	006260047	Wire, Stranded, 12AWG, 300V, AC, Tin Plated, Green
37	1	006260048	Wire, Stranded, 12AWG, 300V, AC, Tin Plated, White
38	3	006270199	Connector, Housing, 9-Pin, Male
39	1	006280578	Power Supply, 100-240 VAC, 50-60 Hz, 60W
40	1	006280643	Touch Screen, PLC HMI, 4.3" Screen, 24VDC
41	1	006280822	Module, Serial Port, Comm
42	3	007660098	Seal, Peripheral, SZ 13
43	2	007660099	Seal, Peripheral, SZ 17
44	6	009097007	Cable Holder, ADH, Plastic, 1/4" Diameter, 5/8" X 3/8" X 3/4"
45	1	06010253	Control Panel Gasket
46	1	06010259	Bezel, Control Panel
47	1	06010271	Back Panel
48	2	06010319	3-Conductor Receptacle
49	1	Purchased	Safety Label, Read Operators Manual
50	1	Purchased	Safety Label, Danger Risk Of Electrical Shock

NOTES:

1. SEE SHEET 2 FOR PANEL CUT OUTS.
2. USE LOCTITE BLUE - 242 ON SCREWS AS REQUIRED.
3. DIN RAILS: MUST USE AT LEAST TWO SCREWS PER DIN RAIL.
EITHER SHOWN OR HIDDEN THREADED HOLES WILL BE USED BASED ON THE PIECE OF DIN RAIL CUT.
4. MOUNTING PANEL 06010271 IS HELD ON USING THE (4) SCREWS THAT ARE INCLUDED WITH THE FIBOX ENCLOSURE
5. USE SILICON 732 TO SEAL RIVETED CONNECTIONS WHEN COMPLETED.
ENSURE WATER TIGHT RIVETED CONECTIONS!
SEAL RIVETS BY INSERTING SILICON NOZZLE INTO RIVET CAVITY AND FILL TO ENSURE COMPLETE WATERTIGHT SEAL.
6. USE WIRE HOLDERS 009097007 WHERE NECESSARY TO ROUTE WIRING.
LOCATIONS DISPLAYED ARE FOR REFERENCE.
7. SEPERATE HIGH AND LOW VOLTAGES.
ROUTE HIGH VOLTAGE WIRES TOWARDS THE TOP OF THE ENCLOSURE WHERE POSSIBLE.
8. ENSURE REAR RECEPTACLES AND PLUG GASKETS ARE WATER-TIGHT.
USE SILICON IF NECESSARY.
9. ALL ENCLOSURE BASE TO LID CONNECTORS SHOULD HAVE 8"-12" LEAD.

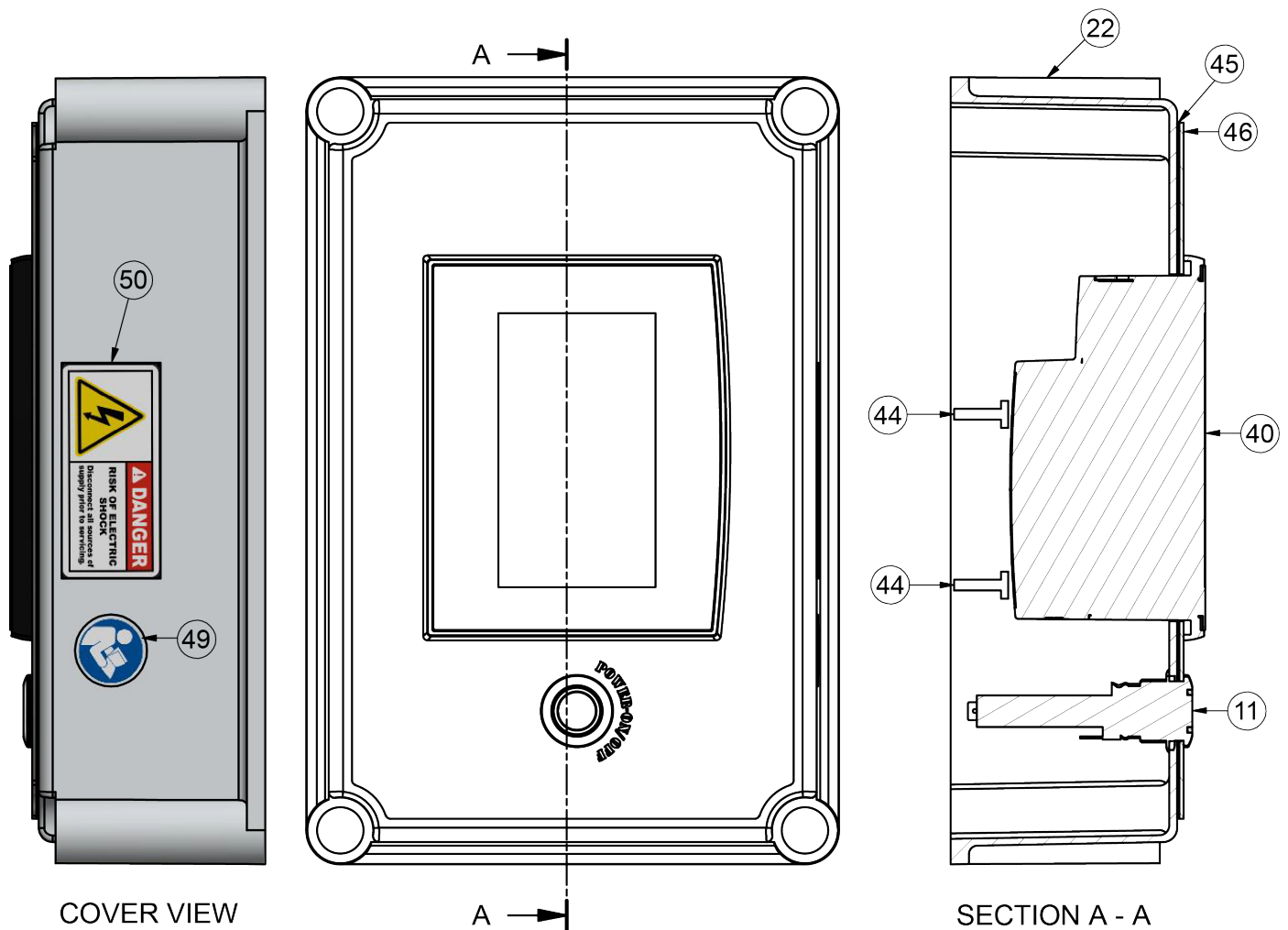

Figure 64. Electrical Panel Assembly (Sheet 1 of 3)

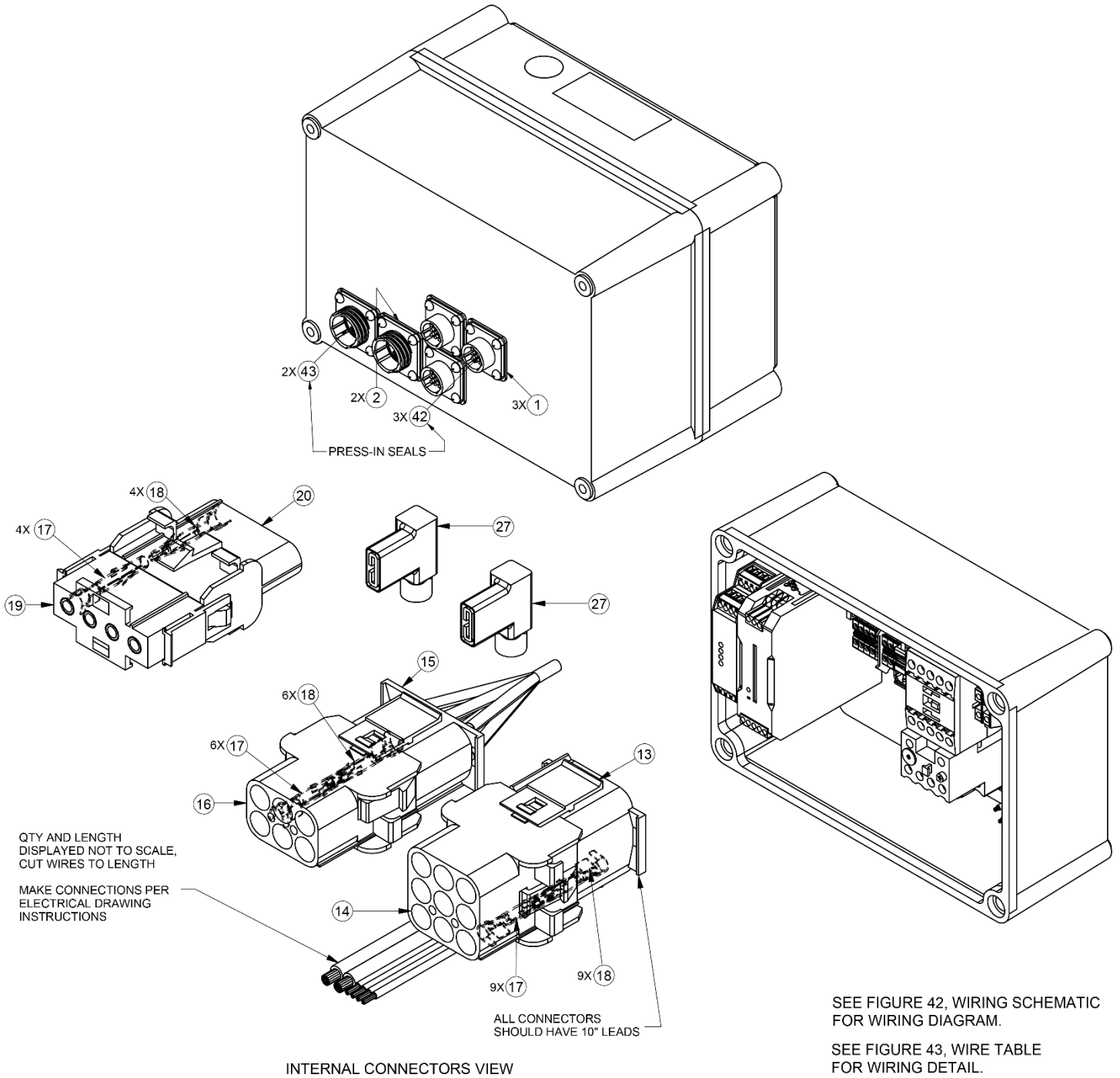
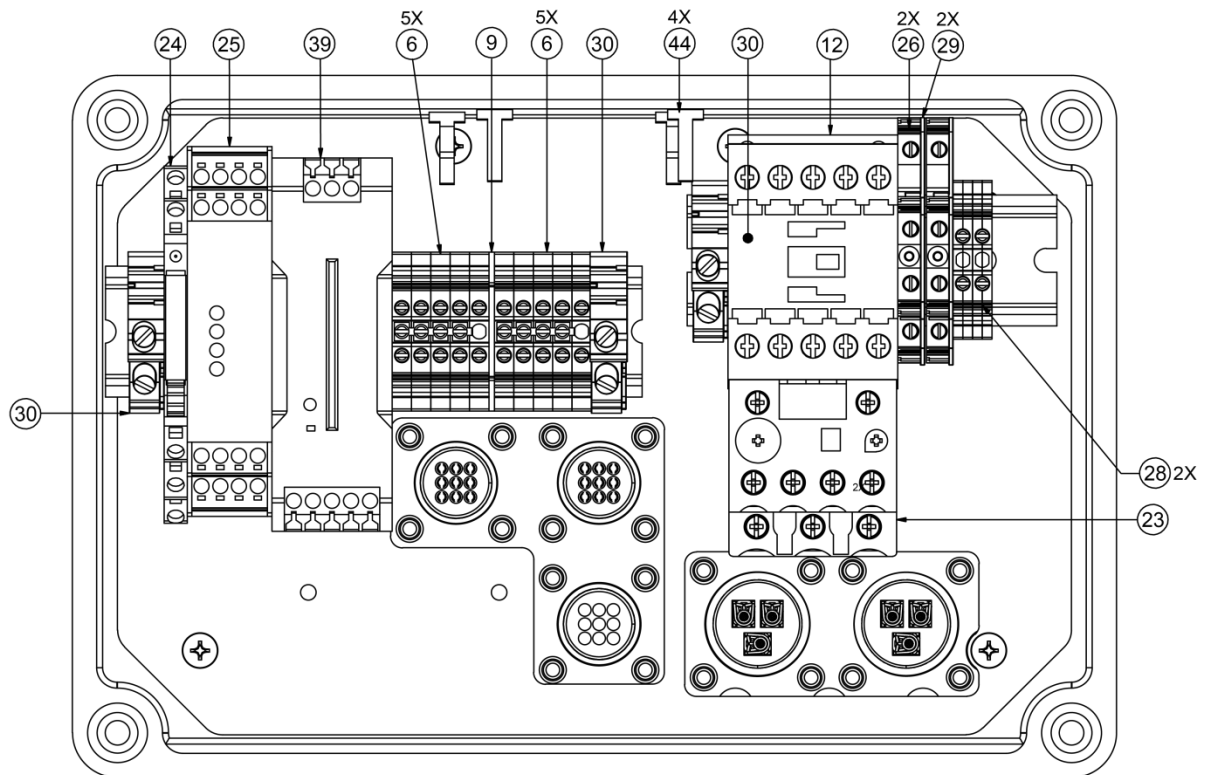
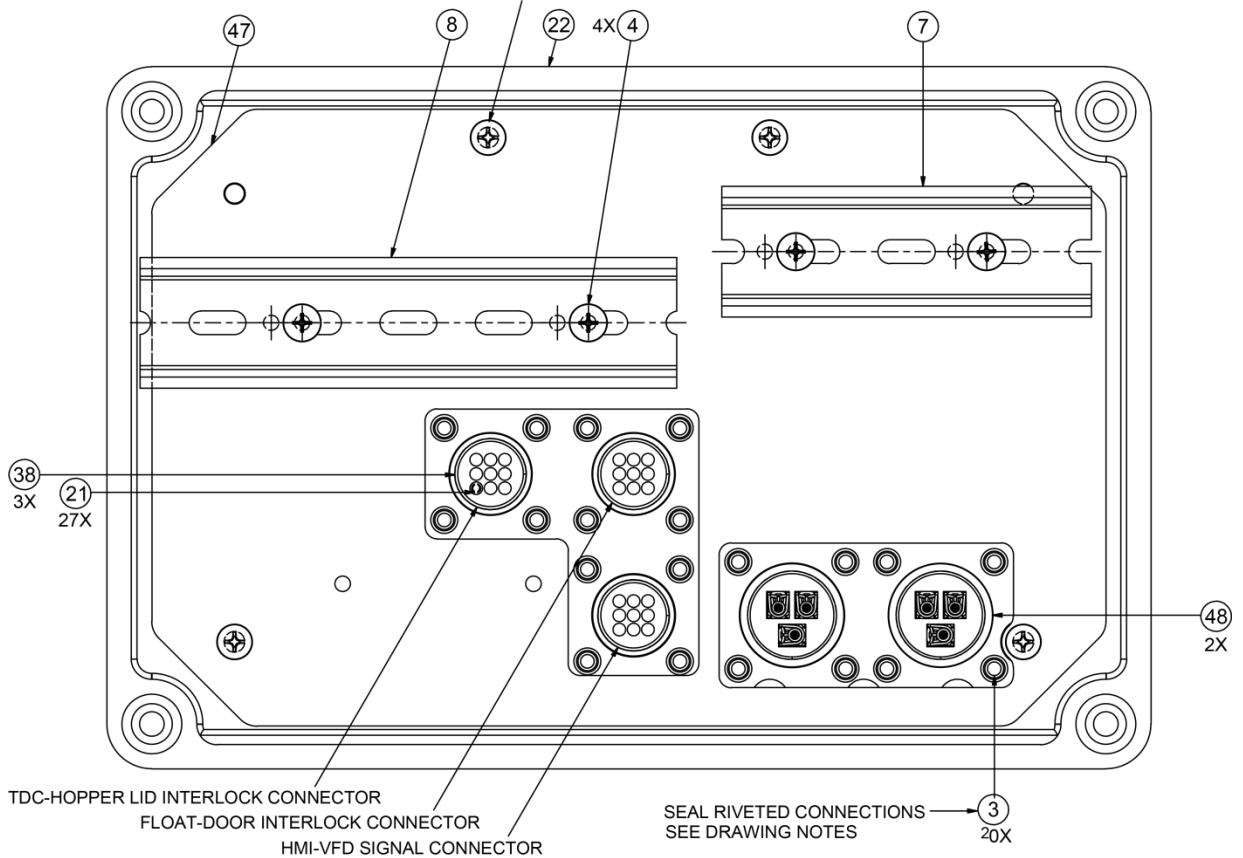

Figure 64. Electrical Panel Assembly (Sheet 2 of 3)



ELECTRONICS COMPONENTS VIEW

USE (4) SCREWS THAT COME WITH 006090306 TO SECURE BACK PANEL



WITHOUT ELECTRONIC COMPONENTS VIEW

Figure 64. Electrical Panel Assembly (Sheet 3 of 3)

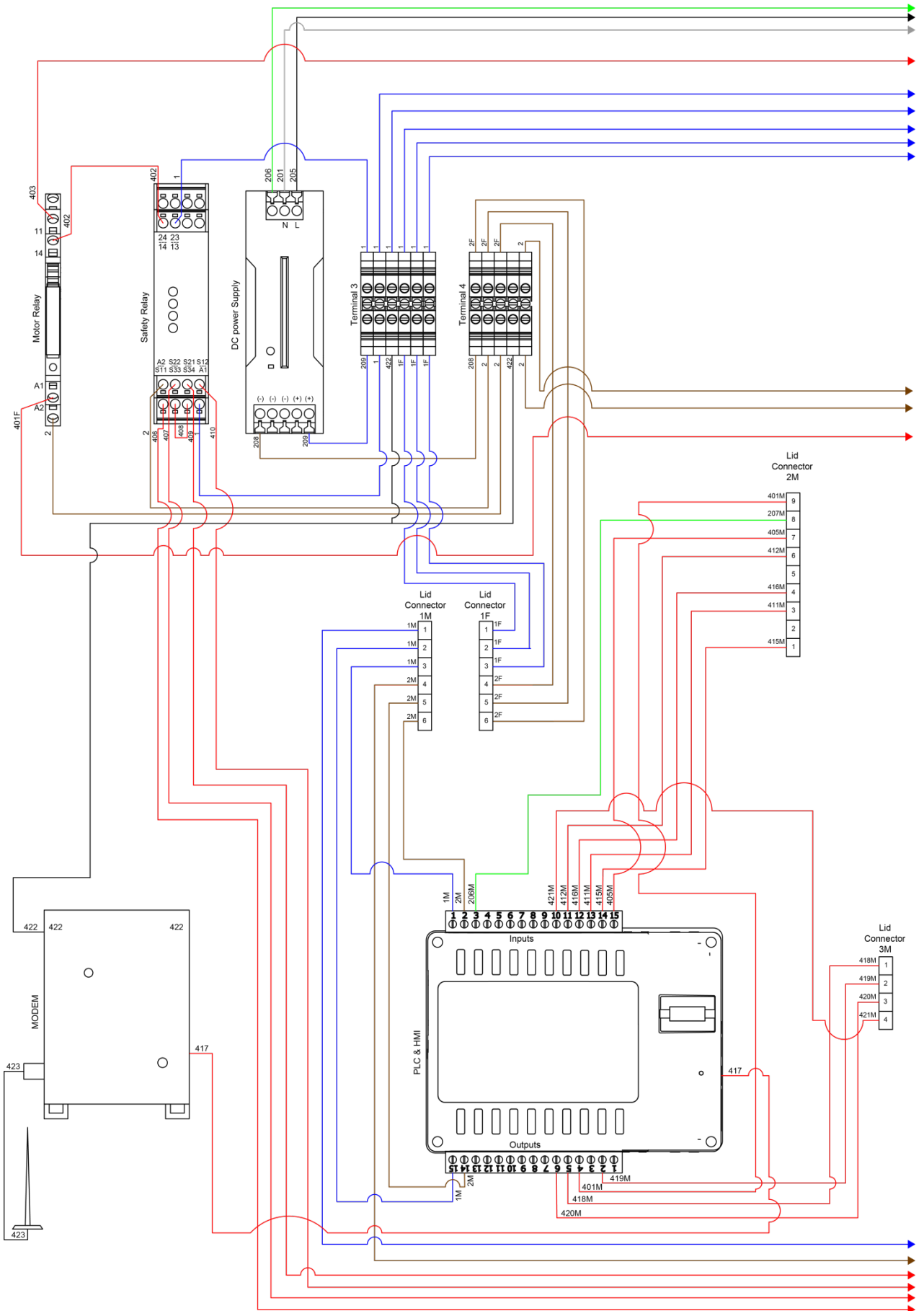

Figure 65. Wiring Schematic, Electrical Panel (Sheet 1 of 2)

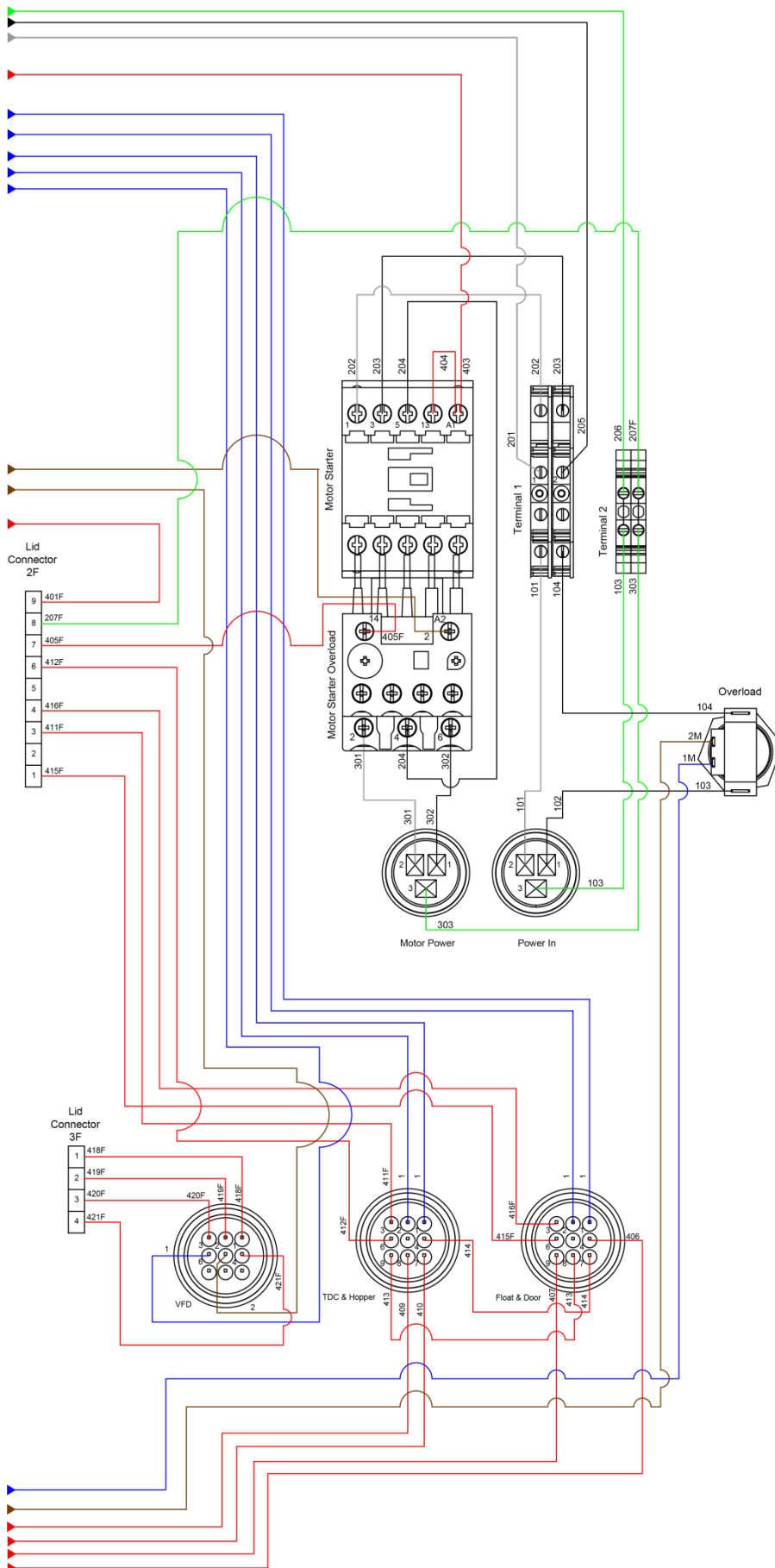

Figure 65. Wiring Schematic, Electrical Panel (Sheet 2 of 2)



Wire Number	Origination Point	End Point	Wire Color	Voltage	Description
1	T3	* SR-13; SR-A1; TH-1; TH-2; FD-1; FD-2	Blue	24	Positive leg 24V power
1F	T3	LC1F	Blue	24	Positive leg 24V power going to the lid connector
1M	LC1M	* PLC-I+V (1); PLC-O+VO (15); Overload-light	Blue	24	Positive leg 24V power on the lid
2	T4	* MR-A2; SR-A2; MSO-A2	Brown	24	Negative leg 24V power
2F	T4	LC1F	Brown	24	Negative leg 24V power to connector for lid
2M	LC1M	* PLC-I0V (2); PLC-O0V (14); Overload-light	Brown	24	Negative leg 24V power on the lid
101	PI-2	T1	White	120	Neutral Line coming into the panel
102	PI-1	Overload	Black	120	Incoming hot line going to overload
103	PI-3	T2	Green	G	Ground coming into the panel
104	Overload	T1	Black	120	Hot line going from overload to panel
201	T1	PS-N	White	120	Neutral line for the power supply
202	T1	MS-1	White	120	Neutral line for the Motor Starter
203	T1	MS-3	Black	120	Hot line for the Motor Starter
204	MSO-4	MS-5	Black	120	Jumper to output single phase power
205	T1	PS-L	Black	120	Hot line for the 24V power supply
206	T2	PS-G	Green	G	Ground for the 24V power supply
207F	T2	LC2F - 8	Green	G	Ground for PLC going to lid connector
207M	LC2M-8	PLC-IG (3)	Green	G	Ground for PLC from lid connector
208	PS(-)	T4	Brown	24	Negative supply for 24V(-) terminal block
209	PS(+)	T3	Blue	24	Positive supply for 24V(+) terminal block
301	MSO-2	MP-2	White	120	Neutral line going to the motor
302	MSO-6	MP-1	Black	120	Hot line going out to the motor
303	T2	MP-3	Green	G	Ground going out to the motor
401F	MR-A1	LC2F-9	Red	24	Box side signal wire for relay controlling starter
401M	LC2M-9	PLC-O0 (4)	Red	24	Lid side signal wire for relay controlling starter
402	SR-14	MR-14	Red	24	Part of Motor Starter control loop
403	MR-11	MS-A1	Red	24	Part of Motor Starter control loop
404	MS-A1	MS-13	Red	24	Part of Motor Starter control loop
405F	MSO-14	LC2F-7	Red	24	Box side signal for if Starter is activated
405M	LC2M-7	PLC-I0 (15)	Red	24	Lid side signal wire for if starter is activated
406	SR-S11	FD-4	Red	24	Part of safety circuit
407	SR-S22	FD-9	Red	24	Part of safety circuit
408	SR-S33	SR-S34	Red	24	Part of safety circuit
409	SR-S21	TH-8	Red	24	Part of safety circuit
410	SR-S12	TH-7	Red	24	Part of safety circuit
411F	TH-3	LC2F-3	Red	24	TDC sensor incoming wire to lid connector
411M	LC2M-3	PLC-I2 (13)	Red	24	TDC sensor lid connector to PLC
412F	TH-6	LC2F-6	Red	24	Hopper safety switch to lid connector
412M	LC2M-6	PLC-I4 (12)	Red	24	Hopper safety switch from connector to PLC
413	TH-9	FD-8	Red	24	Jumper to put both safety switches in series
414	TH-4	FD-7	Red	24	Jumper to put both safety switches in series
415F	FD-6	LC2F-1	Red	24	Door safety switch to lid connector
415M	LC2M-1	PLC-I1 (14)	Red	24	Door safety signal from connector to PLC
416F	FD-3	LC2F-4	Red	24	Tank float sensor to lid connector
416M	LC2M-4	PLC-I3 (12)	Red	24	Float sensor from connector to PLC
417	PLC	Modem	Gray	24	Communication cable with the Modem
418F	VFD-1	LC3F-1	Red	24	VFD start/stop to lid connector
418M	LC3M-1	PLC-O1 (5)	Red	24	VFD start/stop from PLC to connector
419F	VFD-2	LC3F-2	Red	24	VFD speed signal to lid connector
419M	LC3M-2	PLC-A0 (2)	Red	24	VFD speed signal from PLC to connector
420F	VFD-3	LC3F-3	Red	24	VFD reset signal to lid connector
420M	LC3M-3	PLC-O2 (6)	Red	24	VFD reset signal from PLC to connector
421F	VFD-4	LC3F-4	Red	24	VFD fault detection to lid connector
421M	LC3M-4	PLC-I5 (10)	Red	24	VFD fault detection from connector to PLC
422	MDM	T3, T4	Gray	24	Modem power cable (orange & orange-white are +; blue is -)
423	MDM	Attached-Antenna	Black	24	Modem antenna (Antenna integrated into cable)

Guide Term	Description	Guide Term	Description
FD	Float & Door sensor connections	MSO	Motor Starter Overload
LC1F	Lid connector 1 FEMALE (BOX SIDE)	PI	Power Input
LC1M	Lid connector 1 MALE (LID SIDE)	PLC	Program Logic Controller (integrated HMI)
LC2F	Lid connector 2 FEMALE (BOX SIDE)	SR	Safety Relay
LC2M	Lid connector 2 MALE (LID SIDE)	T1	Terminal 1
LC3F	Lid connector 3 FEMALE (BOX SIDE)	T2	Terminal 2 - Ground bus
LC3M	Lid connector 3 MALE (LID SIDE)	T3	Terminal 3 - 24V (+) bus
MDM	Modem	T4	Terminal 4 - 24V (-) bus
MP	Motor Power	TH	TDC & Hopper sensor connections
MR	Motor Relay	VFD	VFD connection point
MS	Motor Starter		

Figure 66. Wire Table, Electrical Panel

36. Programming the VFD

1. With the machine plugged in, turn the power on using the button next to the touch screen.
2. Ensure that both the hopper door and front door are firmly closed.
3. Press the green Start button on the touch screen.
4. At the back of the machine, remove the cover over the VFD.
5. Make sure the Stop LED at the top is lighted. If it is not, press the “Run/Stop” button.
6. Press the “Program/Display” Button until the PGM LED is on.
7. Use the “</Reset” button to change which digit is flashing.
8. Use the “^” and “v” buttons to change the selected digit
9. When the proper setting is selected, press “Read/Enter” to display the current value
10. If necessary, use the arrow buttons from Step 7 and 8 to change the value
11. Once proper value has been entered, press “Read/Enter” and move to the next (if value is already correct then press “Read/Enter” without changing anything)
12. The screen should display “END” then return to the setting.
13. Again use buttons from step 7 and 8 to select the next setting.
14. Settings to be changed (left column) and the value to change to (right column - take note of the decimal place each time a value is entered as it is not always in the same place):

Setting	New Value	Purpose
0.01	→ 05.00	Motor Amps
0.04	→ 0002	Setting to enable operation with GFCI outlets
1.01	→ 0002	Disable the Reverse button
1.05	→ 0004	Auto restart all faults except short circuit (PLC also has its own restart)
1.07	→ 0001	Number of restart attempts
2.02	→ 0002	Disables up or down buttons (does not apply during programing)
** WARNING: Machine will start after next setting is entered. Make sure all safeties are in place before the value is entered**		
2.03	→ 0002	Disables the Local mode (Local/Remote button on VFD)
3.01	→ 15.00	Lower frequency limit (changing this will disrupt normal operation)
3.02	→ 90.00	Upper frequency limit (changing this will disrupt normal operation)
3.03	→ 000.2	Acceleration speed
3.04	→ 000.3	De-acceleration speed
4.04	→ 0001	Display the motor current
4.05	→ 0001	Display the motor voltage
5.00	→ 0001	Enables the motor stall detection

15. When complete, replace the cover on the VFD.
16. Return to the touch screen and acknowledge the error and power the machine off and back on.
17. Machine should be ready to run.

To Factory reset the Drive:

1. Complete step 1 through step 8 above.
2. Go to setting 6.10.
3. Change the value to “1111” and press the “Read/Enter” button.
4. VFD is now ready to be reprogrammed, return to step 7 above.

37. Procedure to Check Safety Cable Assemblies

If either of the following occurs, there is likely an issue with one of the safety sensors found on the MFJ:

- Pressing the start button but nothing happens.
- The safety circuit fault screen appears and all cables are plugged in.

In these cases, which safety has failed will need to be determined before it can be replaced.

Tools that are necessary for this procedure:

- Digital multimeter – preferably with audible continuity
- Spanner bit
- A second person to actuate the sensors is helpful, but not necessary (simply involves holding magnet up to the sensor and removing it)

Necessary steps:

1. Power off the machine and unplug it from the wall.
2. Remove one of the safety magnets to use manually on the sensors. **Refer to Figure 67.**



Figure 67. Location of Front Door Safety Magnet

3. Remove the side access panel on the hopper to access the rear of the electrical panel. **Refer to Figure 68.**



Figure 68. Hopper with Side Access Panel Removed

4. The safety cables will need to be disconnected. These are the two connectors on the top far side of the panel; each has two cables coming out of them. **Refer to Figure 69.**



Figure 69. Location of Safety Cables

5. Bring the connectors to the side panel so they can be accessed with the multimeter.
Refer to Figure 70.



Figure 70. Access to Connectors

6. Locate the numbers and the socket associated with each connector.
Refer to Figure 71.

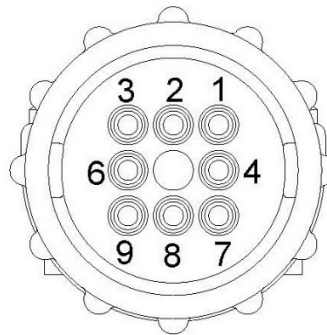

Figure 71. Connector Numbering

7. Select the connector for the front door safety.
8. Place the multimeter's leads into sockets 4 and 7. **Refer to Figure 72.**



Figure 72. Multimeter Lead Positions

NOTE: At this point, it is beneficial to have someone assist. If no one is available, it will be necessary to hold the leads in the sockets with one hand. **Refer to Figure 73.**

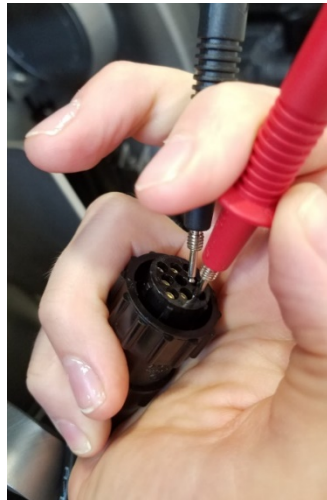

Figure 73. Holding Multimeter Leads

9. While holding the leads to the connector, take the magnet removed from the door previously and align it with the sensor. **Refer to Figure 74.**



Figure 74. Magnet Positioning

10. If the sensor is working properly, there should be continuity between these sockets.
11. Remove the magnet and the sockets should lose continuity. It is important to remove the magnet and check for loss of continuity because the sensor can become stuck in the on position. Therefore, it needs to be confirmed that the sensor turns off and on.
12. If the multimeter does not see continuity, make sure that the magnet is lined up properly. Remove it and line it up again (sometimes if the magnet is held up to the sensor crookedly at first, the sensor will not register it and the magnet must be pulled away and realigned). Also check that the multimeter leads are still firmly set in the appropriate sockets. It is easy for them to slip while trying to position the magnet
13. If the magnet was aligned correctly, the leads are firmly in their correct sockets, and there is still no continuity, then the sensor is bad and will need to be replaced. Continue onto the next sensor to make sure it is still working properly and does not need to be replaced as well. Alternatively, if continuity is detected all the time even when the magnet is not present, then the safety is bad and needs to be replaced.

14. If the sensor is working properly, move the leads to sockets 8 and 9. **Refer to Figure 75.**



Figure 75. Multimeter Leads, Sockets 8 and 9

15. Align magnet with the sensor or have your assistant hold it to the sensor. **Refer to Figure 76.**



Figure 76. Magnet Positioning

16. As with before, if the sensor is working, continuity should exist when the magnet aligns with the sensor and turn off when the magnet is removed.

17. Once completed with the door sensor, set that connector aside and select the hopper safety's connector.

18. The same process is repeated starting with placing the leads in sockets 4 and 7 again. **Refer to Figure 77.**



Figure 77. Multimeter Leads, Sockets 4 and 7

19. Align the magnet with the sensor in the top corner of the hopper's lid. The magnets are not coded and work for either sensor. **Refer to Figure 78.**

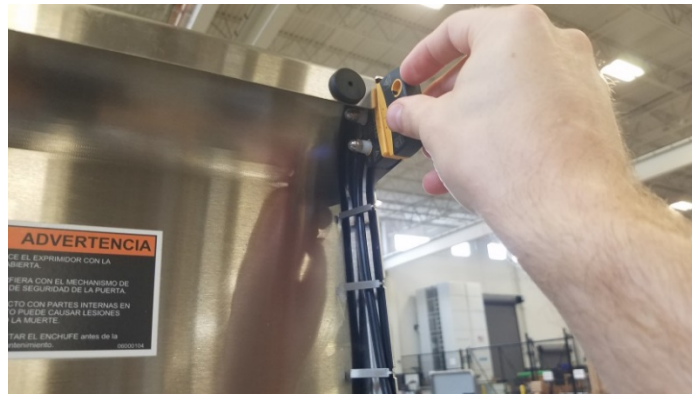

Figure 78. Magnet Positioning

20. Repeat the procedure from before; if continuity is detected when magnet is present and shuts off when removed, the safety is okay.
21. If no continuity is not detected or always detected, realign the magnet and check the position of the leads. If the problem persists, the safety needs to be replaced.
22. Once completed, move the leads to sockets 8 and 9 on the connector. **Refer to Figure 79.**

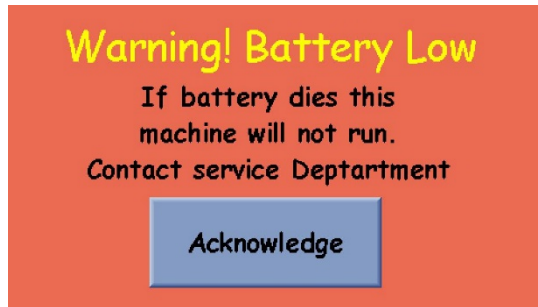

Figure 79. Multimeter Leads, Sockets 8 and 9

23. As before, align the magnet and check for continuity. If continuity is detected when magnet is present and shuts off when removed, the safety is okay. If no continuity is detected or always detected, realign the magnet and check the position of the leads. If the problem persists, the safety needs to be replaced.
24. Replace the necessary safety sensor and cable assemblies.
25. Reattach the connectors to the back of the electrical panel. Attach the hopper connector first to the furthest receptacle. If the door connector is attached first, it is more difficult to attach the hopper connector.
26. Make sure the juicer is working properly.
27. Open the front door and make sure the correct screen appears on the touch screen. If the hopper open screen appears while the front door is open, then the connectors are put on the wrong receptacle and need to be switched.

38. PLC Battery Replacement

When the PLC battery needs to be replaced, the following message will be displayed on the Operator Screen:



The machine can continue to be operated, but eventually the battery will fail and the control system will lose some functionality. Saved data, such as cycle count, service phone number and service date, could be lost and would have to be re-entered. To prevent loss of control system functions, JBT recommends replacing the battery as soon as possible following a low battery warning message.

Recommended replacement battery: Renata CR2450N (alternative batteries may not work)

Necessary steps:

1. Before powering down the machine, take a picture of the status screen or record the cycle count, phone number, and machine serial number (battery removal can occasionally cause these values to be lost, requiring them to be re-entered).
2. Disconnect power plug.
3. Using a flat head screwdriver, open the main electrical box.
NOTE: To prevent plastic screw damage, insert screwdriver into the deeper slot of the plastic screw, as shown in **Figure 80**.



Figure 80. Opening Main Electrical Box

4. Disconnect the cable harnesses in order to remove the lid. **Refer to Figure 81.**

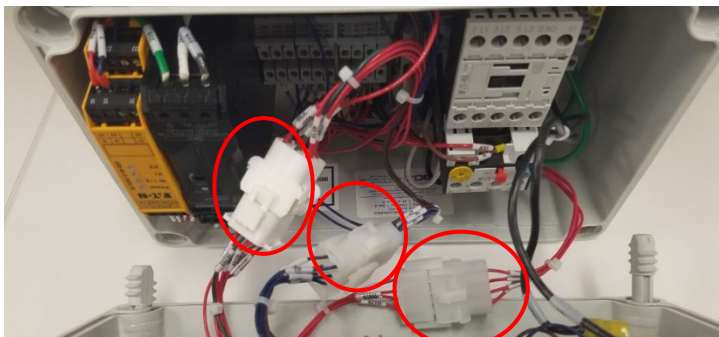

Figure 81. Disconnect Cable Harnesses

5. Be careful when removing the black wires on the overload. If possible, hold the overload itself and rock the connector back and forth to remove the black wires. **Refer to Figure 82.**

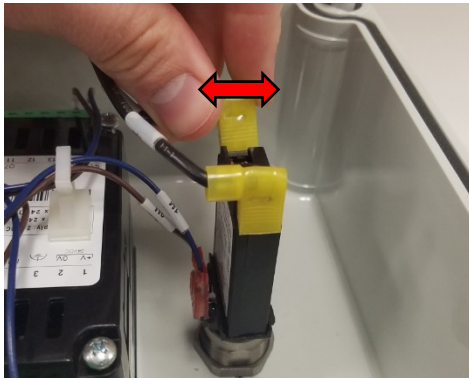

Figure 82. Disconnect Overload Connections

6. Place the lid on a clean flat surface with the touch screen facing down, make sure there is nothing that will scratch or harm the screen. Setting on a clean cloth is preferable.
7. Locate the two green wire terminal strips on the PLC (large black device on the inside of the lid) and detach both of them. May need to use a flat head screwdriver to gently pry them out (wires can be left connected to the wire clamps). **Refer to Figure 81.**

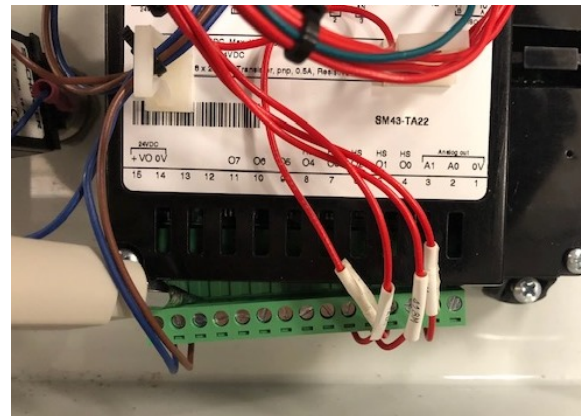
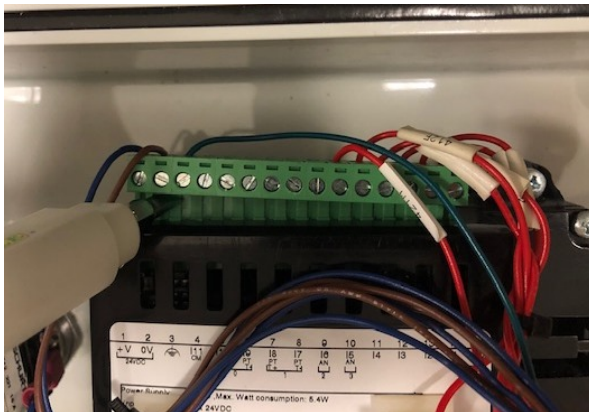

Figure 83. Detach Terminal Strips

Use a phillips head screwdriver to remove the four screws located in the corners of the PLC cover. Do not remove the screws that come off the sides of the PLC. **Refer to Figure 84.**

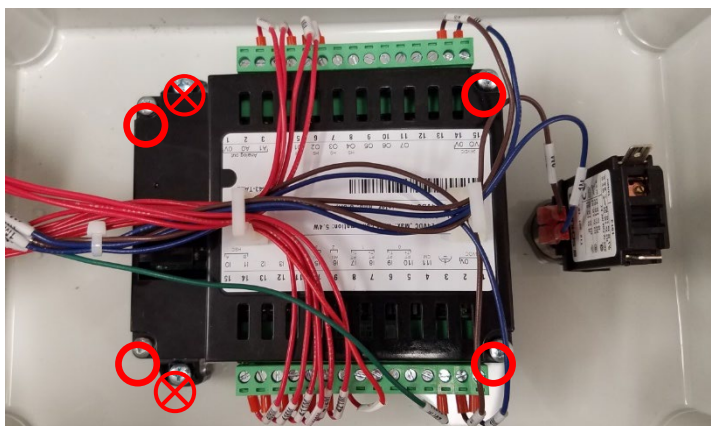

Figure 84. Location of PLC Cover Screws (4)

8. Grip the upper circuit board by the two green strips and gently lift up. If necessary, hold the lower circuit board in place while lifting upper circuit board.. **Refer to Figure 85.**

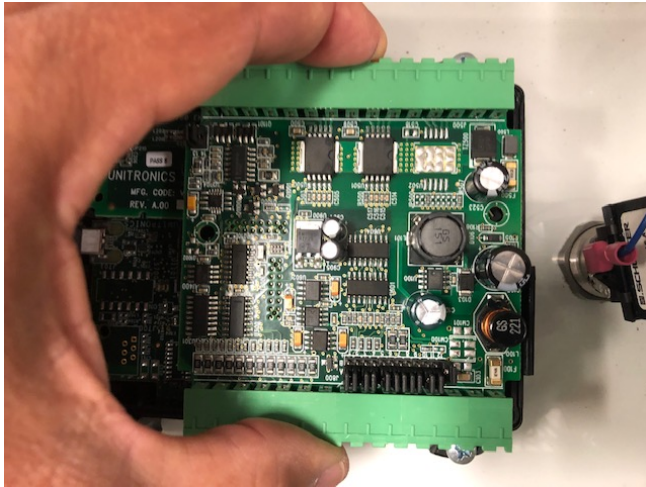

Figure 85. Upper Circuit Board Removal

9. Locate, remove and replace the bad battery with a new battery (CR2450N). One side of the battery housing has a cutout. Lift the battery up from this side and pull out of the housing. Replace with new battery.. **Refer to Figure 86.**

NOTE: Make sure new battery is clean and free of smudges and firmly seated. A loose battery can cause a battery warning message to be displayed even for a new battery.



Figure 86. Battery Replacement

10. THIS STEP IS VERY DELICATE - PROCEED CAUTIOUSLY.

- a. Reinstall the circuit board that was removed, there are two sets of pins on the circuit board that must be lined up on connectors. **Refer to Figure 87.**

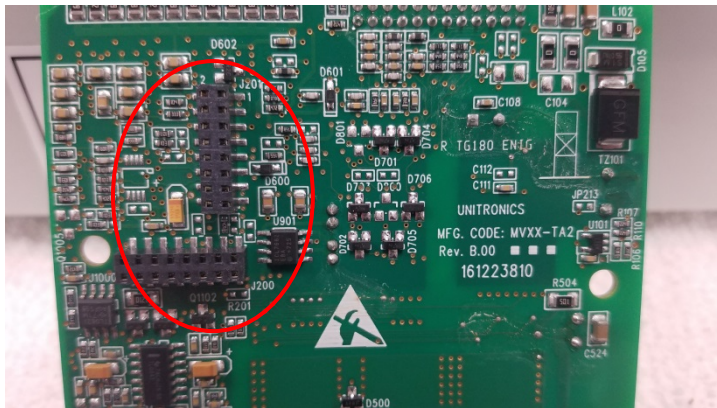
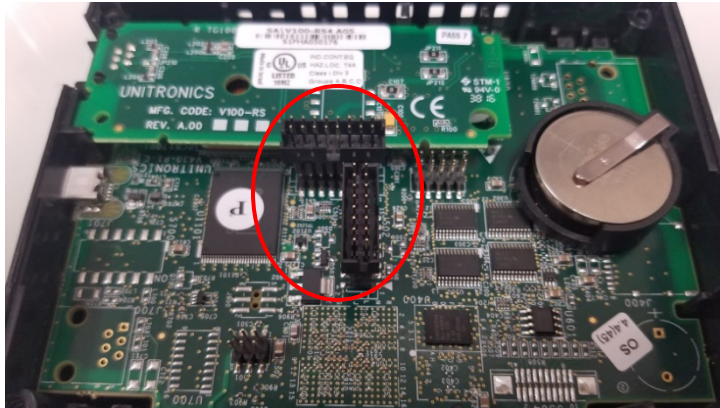

Figure 87. Align Circuit Board Pins and Reinstall

- b. To do this, find the side of the PLC with a small notch on it and find the small piece on the edge of the board that lines up with this.. **Refer to Figure 88.**

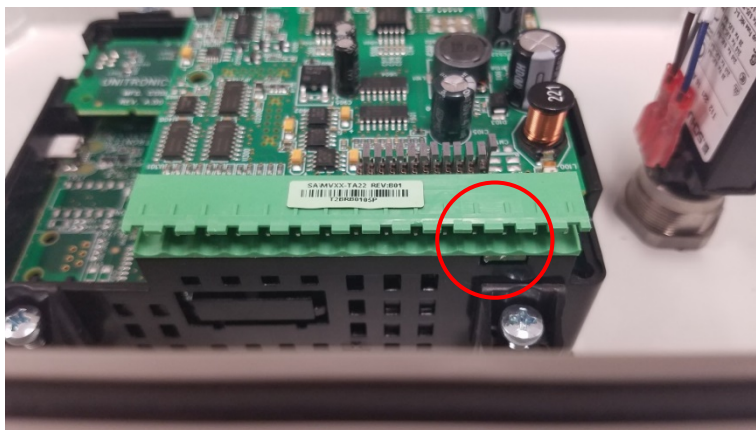

Figure 88. Location of Notch on Side of PLC

- c. Make sure the board lines up with the housing. As seen in the picture above, the ends of the green strip should match to the PLC housing.

- d. Gently push the board down until the green strip is resting on the housing. **Refer to Figure 89**

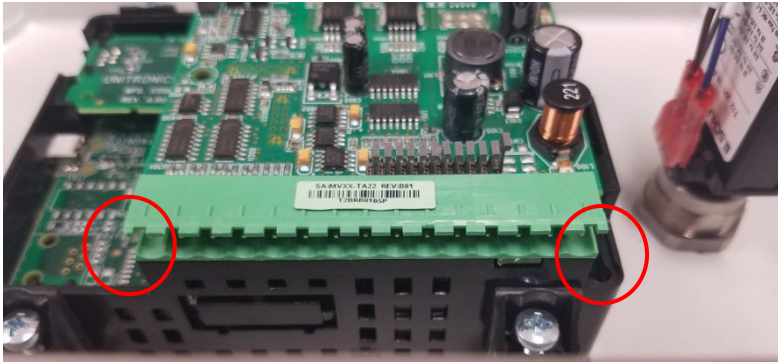

Figure 89. Gently Push Down on Board

11. Replace the back cover of the PLC.
12. Reinsert the four screws that were removed from cover. There are two different size screws used, the short ones go to the lower end of the cover while the longer screws are on the higher end, closest to the on and off switch. **Refer to Figure 90.**



Figure 90. PLC Cover Screws

13. Reattach both green wire terminal strips. Use the numbering system on the PLC to insure the proper connections.

The terminal strip with 6 wires goes on the side with 0V over the 1 position and V+ over the 15. The terminal strip with 9 or 10 wires (depending on model) goes on the side with 10 under 15 and V+ under 1. **Refer to Figure 91.**

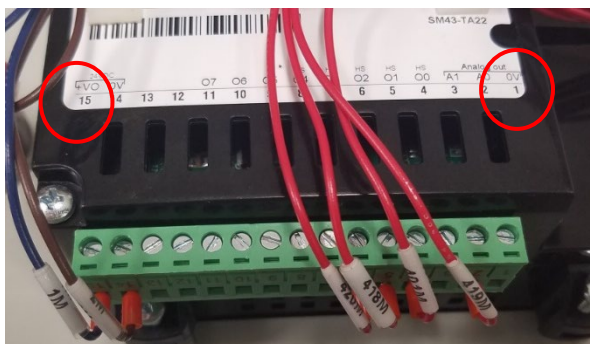

Figure 91. Reattach Terminal Strips

14. Insure both terminal strips are firmly seated. Leaving them loose can lead to intermittent issues during operation or leave the machine unable to run. **Refer to Figure 92.**

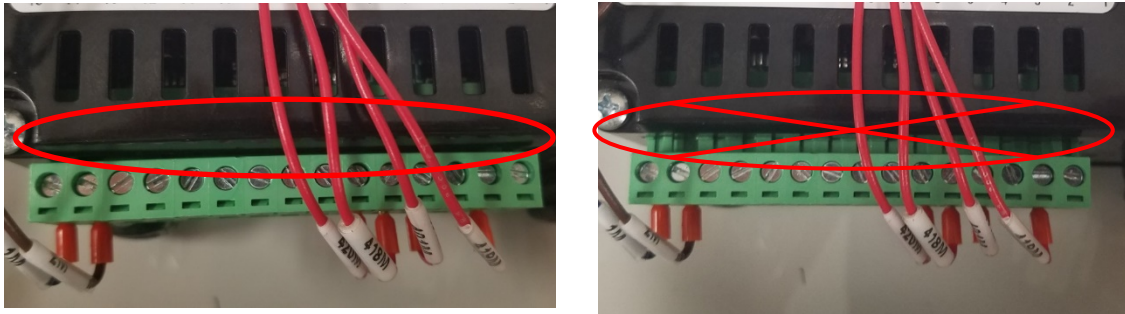

Figure 92. Firmly Seat Terminal Strips

15. Reattach electrical box lid including the two black wires and three cable harnesses that were disconnected in Step 4.
16. Close electrical box and tighten plastic screws with flat head screwdriver.
17. Reconnect electrical plug.
18. Power up the machine and ensure that the battery warning message does not reappear. (If the new battery was not properly seated, the warning message will likely appear within 5 seconds after the JBT screen clears).

NOTE: If battery warning message reappears, repeat the procedure making sure the new battery is smudge-free and firmly seated. If problem persists, repeat the procedure with a different new battery.

19. If the battery warning screen does not reappear, battery replacement was successful. Check the status screen to determine if service data was saved. If not, enter the service screen and reset all necessary data.



www.jbtcorporation.com