



Operator & Service Manual Citrus Juicer



November 2017



Operator & Service Manual Citrus Juicer

Copyright © John Bean Technologies Corporation 2017

JBT Corporation
400 Fairway Avenue
Lakeland, FL 33801
(863) 683-5411

Manual No. FNS-0006-060-EN



Safety Information	4
Safety Instructions	5
Technical Specifications	6
General Information	7
Operating Instructions	10
Cleaning Instructions	12
Maintenance	16
Periodic Inspection	19
Troubleshooting-Operator	21
Troubleshooting-Service	24
Rebuilding	27
Rebuild Tooling Kits	42
Drive Parts	44
Juicing Parts	46
Cart Assembly Enclosed Parts	48
Electrical Parts (110 Volt)	50
Electrical Parts (220 Volt)	54
Electrical Box Assembly	56
Cover Parts	58
Hopper Parts – Low Profile	60
Hopper Parts – High Capacity (Round)	62
Waste Container Assembly	64
Miscellaneous Parts	66



Important Safety Information

You can help prevent personal injury and/or property damage.

Please read this manual carefully before operating the JBT Corporation Citrus Juicer.
DO NOT attempt any operation until you understand exactly how the machine functions.

If uncertainty remains after studying this manual, please contact:

John Bean Technologies Corporation

JBT Corporation
400 Fairway Avenue
Lakeland, FL 33801
863.683.5411

or

The local JBT Corporation service representative in your country.

We're here to help. With proper handling, the JBT Corporation, Fresh 'n Squeeze Citrus Juicer will provide safe, efficient and convenient service for years to come.

Revision History

Manual Code	Rev. No.	Date	Pages	Change History
FNS-0006-060-EN	A	5/6/15	Entire manual	Updates, modifications and alignment to JBT global version control and inventory standards
FNS-0006-060-EN	B	12/15/15	Entire manual	Addition of new Fresh 'n Squeeze logo
FNS-0006-060-EN	C	7/19/16	50, 51, 52, 53, 56	Updates to part numbers and/or drawings for assemblies 060-02005, 060-02005-01, 060-02005-02, 060-02003
FNS-0006-060-EN	D	12/14/16	64	Update to part description 060-00296
FNS-0006-060-EN	E	1/19/17	50, 52, 53	Addition of information for motor conversion kit, 060-10157
FNS-0006-060-EN	F	11/10/17	Entire manual	Edits and additions

Safety Labels

The safety labels shown below appear on the Citrus Juicer. They provide essential instructions on how to avoid possible hazards.

Please, for your safety: FOLLOW THOSE INSTRUCTIONS AT ALL TIMES.

Should the Citrus Juicer safety labels become damaged or unreadable, contact JBT Corporation for replacement labels.

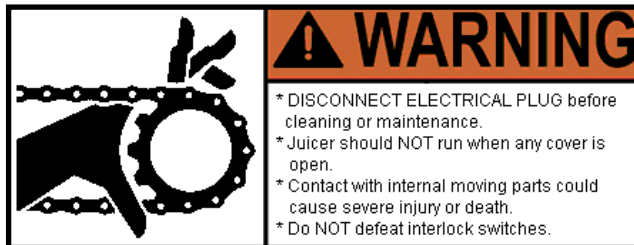

Safety Instructions

Carefully review the following safety instructions. Make them a habit when using the JBT Corporation Citrus Juicer.

1. If Citrus Juicer continues to run when any access cover is open, interlock switch is defective.
Turn Juicer off and unplug immediately. Call for service.
2. Prevent unauthorized access to Citrus Juicer by locking all covers with supplied key.
3. **NEVER** attempt to make any safety device inoperative.
4. **NEVER** operate or perform maintenance or repair work on Citrus Juicer when taking any kind of drug or sedative, when under the influence of alcohol, or when fatigued.
5. **ALWAYS** check adjustment of all nuts, bolts, and screws after installation, repair, or periodic maintenance.



Technical Specifications

Fruit Size: 2-1/2" to 3-1/4" major diameter
 Oranges - FL:..... 125 to 80 count
 Oranges - CA: 138 to 88 count
 Lemons, Limes: 138 to 115 count
 Holding capacity: 15 to 20 fruit
 Speed: 10 fruit/minute
 Waste container capacity: 30 to 40 fruit
 Optional for customer to put hole in counter.
 Optional cart and waste container on wheels available.

Electrical Specifications

115V 60HZ Single Phase
 Or
 230V 50HZ Single Phase
 12 GA. wire - up to 100 ft. from main breaker panel or
 10 GA. wire - up to 200 ft. from main breaker panel

Shipping Specifications

Machine without cart:	With cart:
Height: 32"	62"
Width: 18"	24"
Depth: 22"	22"
Weight: 200 lbs.	250 lbs.



General Information

The JBT Corporation Citrus Juicer is designed to provide years of dependable service. It uses a unique patented design to extract every available amount of juice from the fruit with the least amount of peel oil. The peel is completely separated from the juice and juice sacs before being compressed and strained.

The machine will juice oranges, lemons, limes, tangerines, etc., without changing or adjusting parts. In fact, different varieties of fruit can be juiced to create various fruit juice blends.

Clean up is simple, requiring disassembly of only five parts. All waste material - peel, membranes, and seeds - is collected for easy removal and disposal.

The Citrus Juicer is solidly built using heavy-duty components in all assemblies, including the drive. It is simple to operate and uses a minimal number of parts.

ALWAYS follow cleaning and maintenance schedules in this manual to prevent equipment damage.

For a quick introduction to the JBT Corporation Citrus Juicer, please review the diagram on the next page.

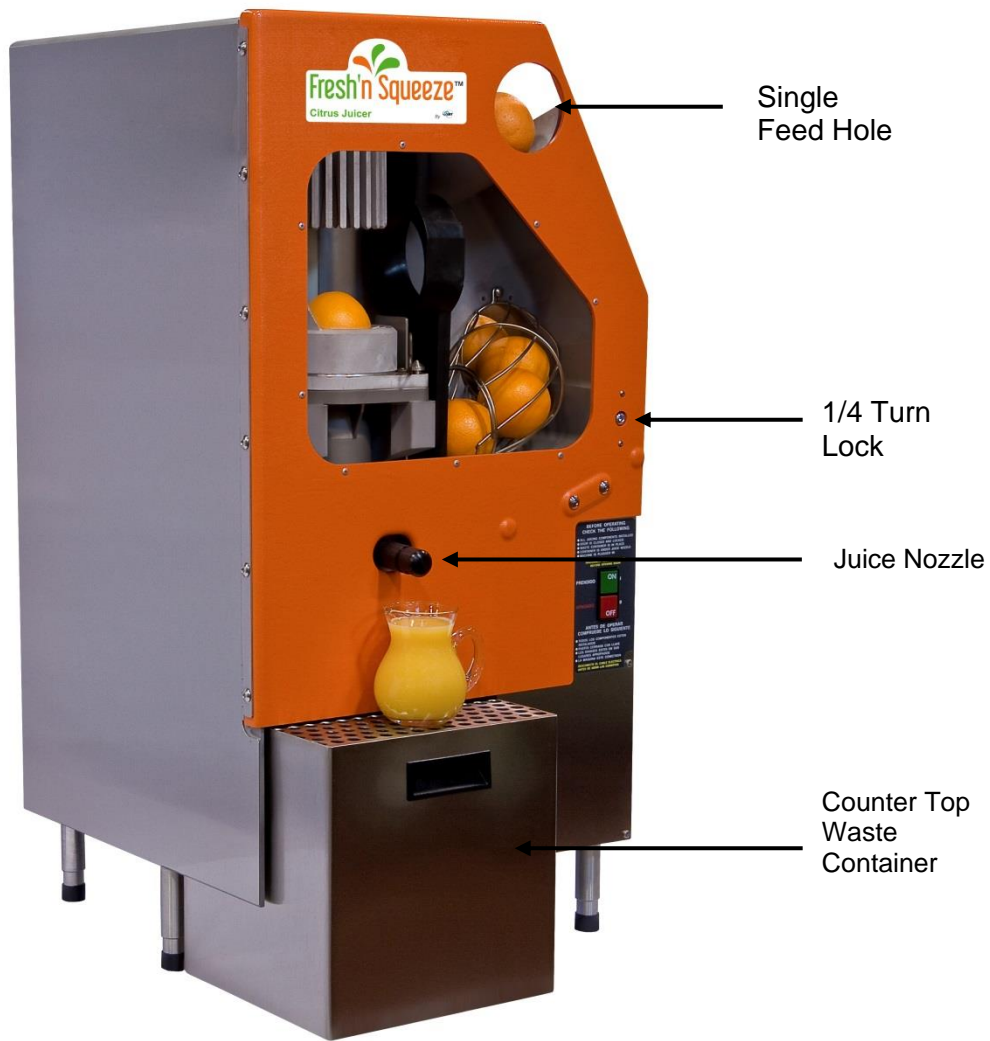

Figure 1a. JBT Corporation Citrus Juicer

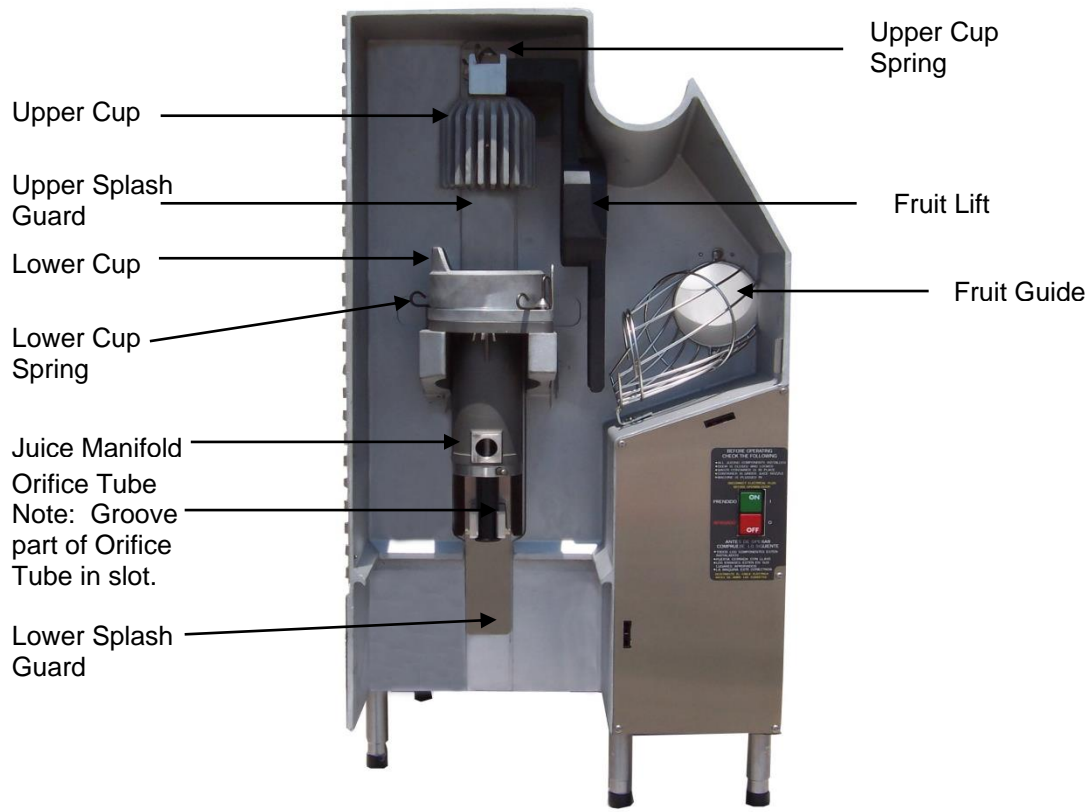

Figure 1b. Juicing Components Assembly

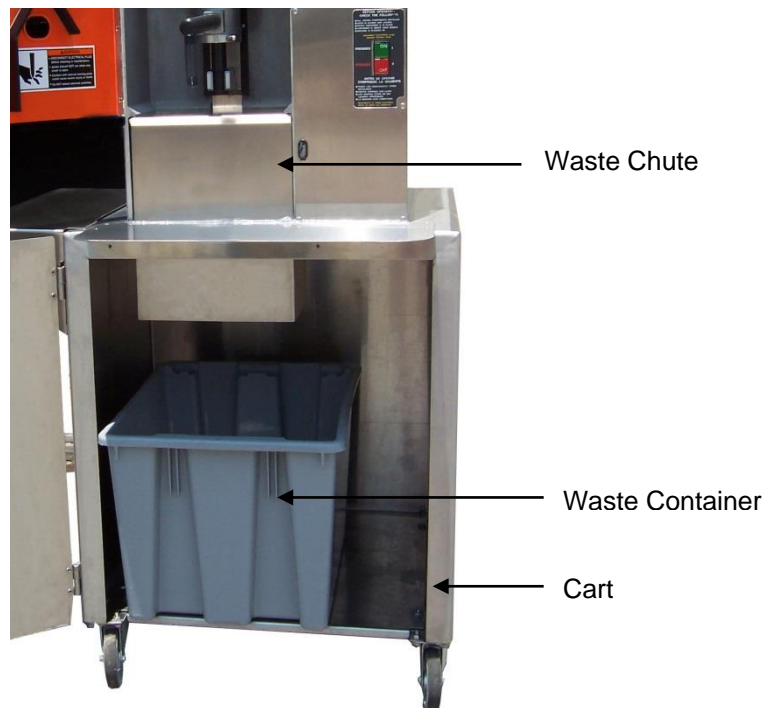

Figure 1c. Optional Cart & Waste Container



Operating Instructions

Equipment Check

Before plugging the JBT Corporation Citrus Juicer into an electrical outlet, the following steps must be performed:

- 1. Locate the Citrus Juicer on a level surface.**
This will prevent fruit feed problems.
- 2. Check waste container.**
Make sure that waste container is in place.
- 3. Check juicing components**
Use key to unlock juicing components cover. Open cover and check that juicing components are installed and securely fastened. See **Figure 1b, page 9**.
- 4. Close and lock access cover.**
Juicing component cover must be locked. Counter top waste container (if used) must be in place with key engaged. NEVER operate Citrus Juicer unless all covers are in place.
- 5. Replace juice nozzle.**
- 6. Make sure juice collector is in place.**
- 7. Check the fruit feed chute or hopper for foreign objects.**
Remove any foreign objects found in the chute or hopper.
- 8. Make sure floor area around Citrus Juicer is clean and free of obstructions and water.**
When water is necessary, wear appropriate non-slip footwear.



Operating Instructions

Juicing

CAUTION: DO NOT RUN THE CITRUS JUICER WITHOUT FRUIT FOR MORE THAN ONE MINUTE; IT CAN RESULT IN EQUIPMENT DAMAGE.

CAUTION: READ AND UNDERSTAND THE SAFETY AND OPERATING INSTRUCTIONS BEFORE OPERATING THE CITRUS JUICER.

1. **Turn on Citrus Juicer.**
Push the "ON-OFF" button to "ON" position.
2. **Fruit may be fed into the Citrus Juicer one at a time (Single Feed) or in bulk, using optional hopper.**
 - a. **Single Feed**
DO NOT overload chute or fruit will accidentally be double fed. Fruit chute can be loaded from the side with several fruit at a time, or can be fed one at a time through hole in cover which is sized for max. fruit diameter.
 - b. **Bulk Feed - Optional Hopper**
Dump approx. 1/2 carton (20 lbs.) of fruit into the hopper. Fruit may be divided between the carton and carton lid for ease of lifting.
3. **DO NOT use the single-feed chute when optional hopper is mounted on machine.**
4. **Turn off Citrus Juicer.**
Push the "ON-OFF" Switch to the "OFF" position.
5. **Dispense juice.**
Fresh juice will separate.
Stir before dispensing.
6. **Clean Citrus Juicer.**
If finished juicing, clean Citrus Juicer as soon as possible.
(See next page for cleaning instructions.)



Cleaning Instructions

ALWAYS follow cleaning and maintenance schedules in this manual to prevent equipment damage.

Clean Citrus Juicer as soon as possible after juicing. Use a soft towel or sponge to wipe equipment parts. **DO NOT** use abrasive pads such as Scotch Brite®, steel wool, etc.

The recommended cleaner is JBT Corporation brand CorKlean. CorKlean is a low-foaming alkaline equipment cleaner. It is safe on aluminum, 100% water soluble and free rinsing. CorKlean has been especially formulated for cleaning food processing equipment. Follow instructions on cleaner label for dilution.

2. **Turn off Citrus Juicer with Juicing Component cups separated and Upper Arm in highest possible position.**
3. **DISCONNECT ELECTRICAL PLUG.**

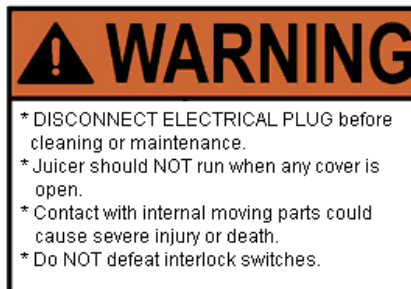

3. **If Citrus Juicer is on optional cart, pull Citrus Juicer to clean-up area, if one is available.**



4. **Brush all loose peel into waste container or bag.**
5. **Empty and rinse waste container.**



Cleaning Instructions

6. Remove juicing components.

- a. Cups should be separated. (Citrus Juicer should be operated a couple cycles just before disassembly and have been turned off with cups in the separated position.)
- b. Grasp upper cup and release by flexing spring. Place upper cup in soaking container.

CAUTION: DO NOT PLACE HANDS OR FINGERS BETWEEN CUPS.

- c. Remove lower cup by squeezing spring and lifting up. Place lower cup in soaking container.

CAUTION: CUTTER AND KNIVES ARE SHARP.

- d. Install red protective cap on cutter. (Red protective cap is provided.)
 - e. Loosen strainer tube prior to removing manifold.
 - f. Grasp juice manifold and orifice tube firmly. Remove entire juicing components assembly.
 - g. Grasp orifice tube and pull out of strainer tube. If orifice tube cannot be removed, re-assemble to juicer, with lower cup in place, and operate a couple of cycles.
 - g. Remove strainer tube from inside juice manifold by turning tube counter-clockwise and sliding out. Place juicing components into soaking container.
- 7. Prepare cleaning solution.**
JBT Corporation brand CorKlean is recommended, see page 12. Read the product label. Follow the manufacturer's mixing directions and safety precautions.
- 8. Immerse all components in cleaning solution.**
Prior to immersing use the blunt end of plastic rod provided to displace any fruit material lodged in the bore of the orifice tube.
Use pointed end of plastic rod to displace any fruit material lodged in cup fingers.

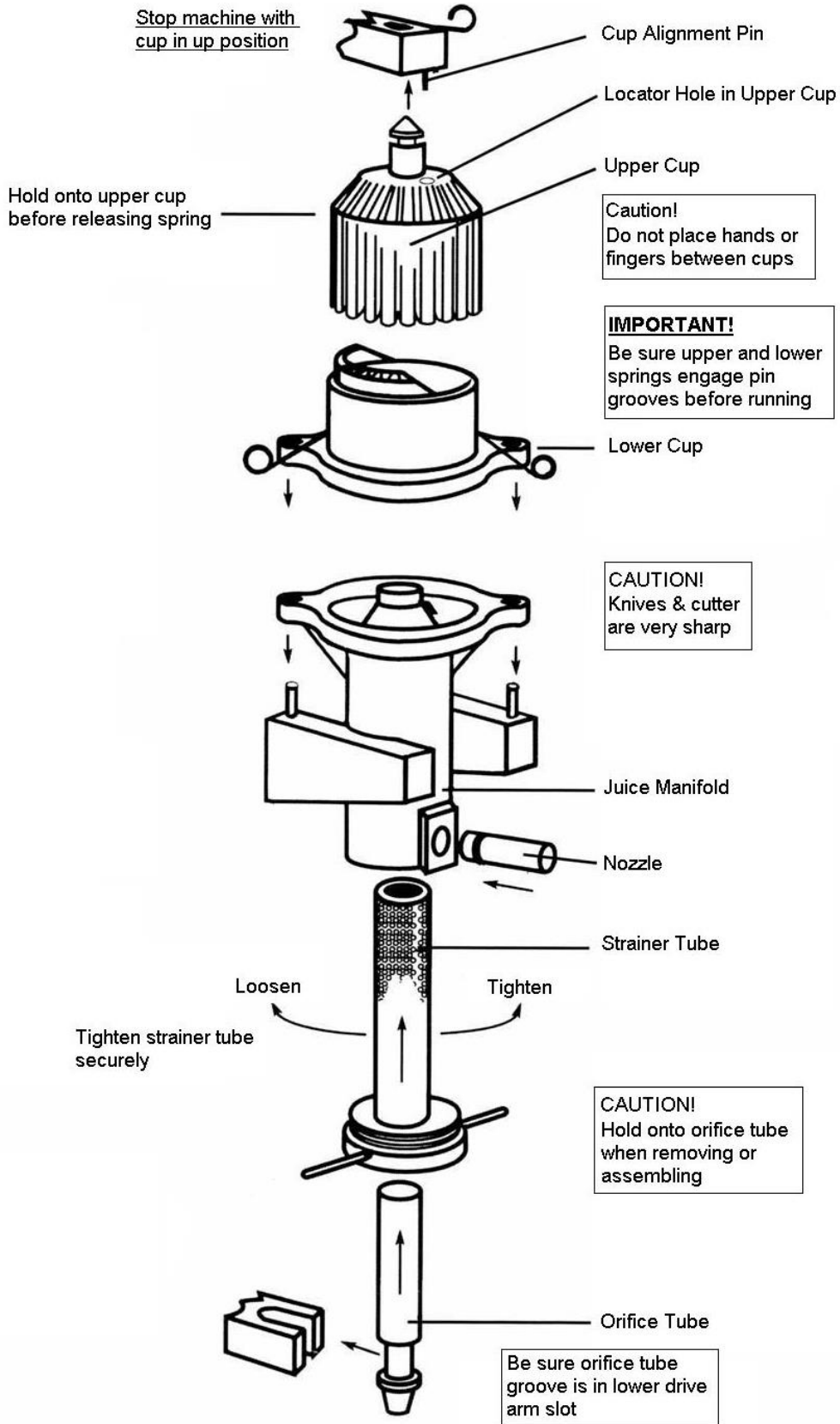

Figure 2. Juicing Components



9. Scrub components.

Use a brush, towel, or sponge. **DO NOT** use abrasive pads such as Scotch Brite®, steel wool, etc. Thoroughly rinse with clean water, then thoroughly rinse with sanitizer solution. Follow the manufacturer's mixing directions and safety precautions. As an alternate cleaning method, all juicing components can be put in a dishwasher. If this method is used, components should be washed in CorKlean at least once a week. **DO NOT** soak aluminum cups longer than 30 min. Then, rinse and sanitize.

10. For best results, soak strainer tube in CorKlean overnight.

After soaking overnight, rinse the strainer tube thoroughly before using. Check that all strainer tube holes are clean. Clean strainer tube with a hard spray from a hose while moving orifice tube back and forth in strainer tube. **Rinse thoroughly with sanitizer solution. Allow to air dry.**

11. If possible, hose down juicing area and cover.

If location prohibits using a hose to clean juicing area and cover, ensure waste container is in place. Wash down the exposed juicing area and cover with a sponge or spray applicator using the recommended cleaning solution. Cover may be rinsed in place. Allow to stand for two minutes before rinsing thoroughly with water.

12. Re-assemble juicing components.

Start by re-assembling strainer tube into juice manifold, and tightening. Insert orifice tube into bottom of strainer tube. Mount juice manifold assembly onto locating pins with orifice tube notch engaging lower drive. Remove red protective cap from cutter. Install lower cup and be sure spring snaps into pin grooves. **Install upper cup by slipping pin into stem hole, and turning until alignment pin engages cup. Be sure spring engages.**

13. CorKlean solution can also be used to remove smudges and finger marks from aluminum exterior of Citrus Juicer. This should be done periodically to maintain the exterior appearance of the machine.

14. Remove wax build-up as needed. (1 tablespoon of ammonia in 32 oz. spray bottle)

Cups, feed chute, and other parts may acquire a build-up of wax overtime.

- a. Soak cups for five minutes in an ammonia cleaning solution. Rinse thoroughly with sanitizer solution.
- b. Wipe feed chute and other parts with a cloth soaked in ammonia cleaning solution. Rinse thoroughly with sanitizer solution.

15. Remove orange discoloration as needed.

Equipment may exhibit some build-up or orange coloration over time. Wipe with a cloth soaked in CorKlean solution. Rinse thoroughly with sanitizer solution.



Maintenance

Before performing any maintenance, DISCONNECT ELECTRICAL PLUG.

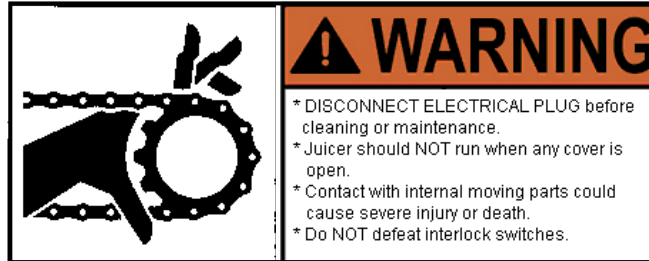

After every juice run:

- 1. Check cutter and knives for sharpness.**

CAUTION: CUTTER AND KNIVES ARE SHARP.

Refer to Figure 3 to determine condition of cutter.
If dull, sharpen with a whetstone.

Refer to Figure 4a. to sharpen cutter.

If cutter is severely damaged or rolled over, replace cutter.

a. Cutter removal:

Disassemble juicing components per **Figure 2, page 14**. Install red protective cap provided onto cutter. After red protective cap is installed, remove cutter. Handle cutter with care to avoid direct contact with sharp edge. Loosen set screw under front knife (make sure screw is backed out far enough to clear cutter). Cutter should lift out. If not, tap the cutter lightly from inside the juice manifold with 1-1/4" dia. rod (hammer handle).

b. Cutter installation.

Align arrows on cutter and juice manifold to seat cutter. Make sure cutter is fully seated. Tighten setscrew. **DO NOT** over tighten.

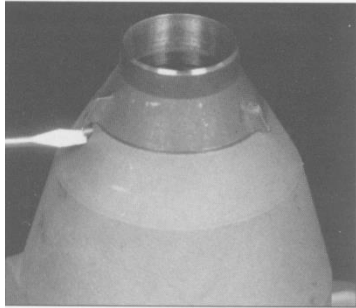

Figure 3. Installation of good cutter

Figure 3a. Bad cutter- REPLACE cutter



Figure 3b. Cutter that can be sharpened

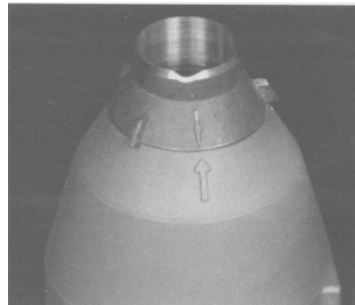

Figure 4a. Sharpening Cutter with Whetstone

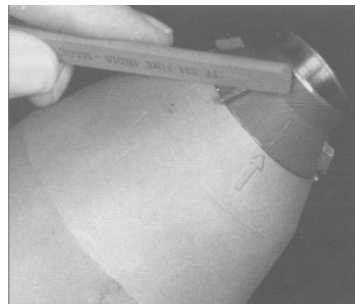

Figure 4b. Sharpening knife with Whetstone



Maintenance

2. **Check orifice tube for damage.**
Refer to Figure 5.

Replace tube when:

- a. Chunks are missing from top end.
- b. Score marks 1/32" or deeper appear along the length of the tube.

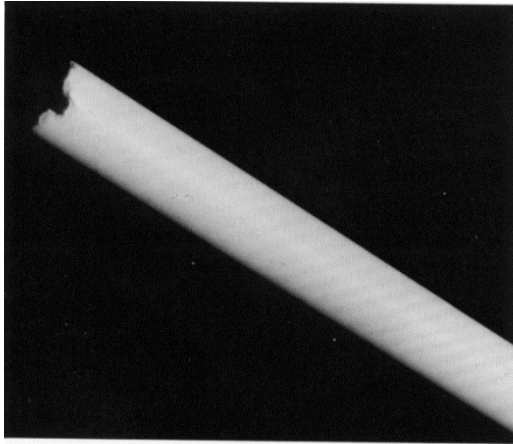

Figure 5. Severely Damaged Orifice Tube

3. **Check for loose or missing nuts and bolts.**
 - a. **Tighten or replace nuts and bolts as necessary.**
 - b. **DO NOT** exceed torque ranges specified in Operator & Service Manual.
 - c. **ALWAYS** use JBT Corporation recommended spare parts.

Periodic Inspection by Service Technician

Perform the following steps after every 3-4 months.

1. Test all interlock switches.

The Citrus Juicer should stop automatically when juicing cover is opened. If juicer is a counter top model, Citrus Juicer should stop when waste container is pulled out. If Citrus Juicer continues to run when either is opened, the interlock switch is defective.

Stop the Citrus Juicer and replace immediately.

See Troubleshooting Section.

2. Check all fasteners for tightness.

Remove back cover with spanner (snake eyes) security tool. Check especially on the Sprockets, Crank Arms, Fruit Lift and Hopper.

3. Check chain for tightness.

Refer to Figure 6a. and 6b.

Chain should have 1/4" maximum slack on top side. To adjust, loosen the two bolts holding the chain take-up bracket to frame, pry bracket up to the correct adjustment.

CAUTION: DO NOT OVERTIGHTEN CHAIN.

4. Check chain and sprockets for rust.

If rust appears, coat chain and sprockets with a small amount of Teflon grease.

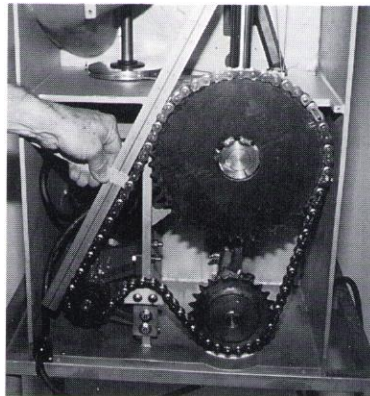

Figure 6a. Checking chain slack

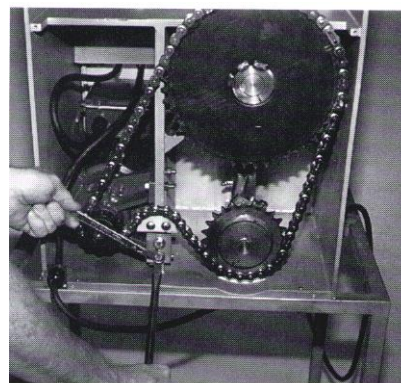

Figure 6b. Loosening bolts on chain take-up bracket and prying up



**5. Grease Fittings
Refer to Figure 7.**

Using a grease gun with a flexible hose, grease seven fittings with Super Lube®Teflon grease. Try to force grease into thrust washer between crank arms/sprockets and the main frame.

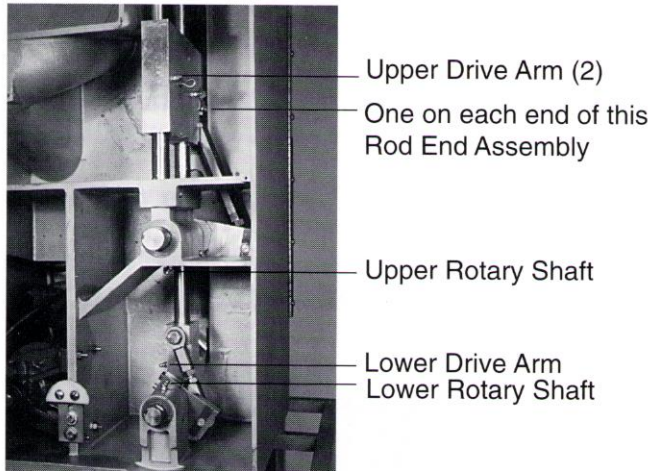

Figure 7. Grease Fitting Locations

**6. Check optional hopper shaft seal & slinger.
Refer to Figure 8a. and 8b.**

Shaft seal prevents water from getting into back of Citrus Juicer, replace if defective. Slinger prevents water from getting into one way clutch, replace if defective.

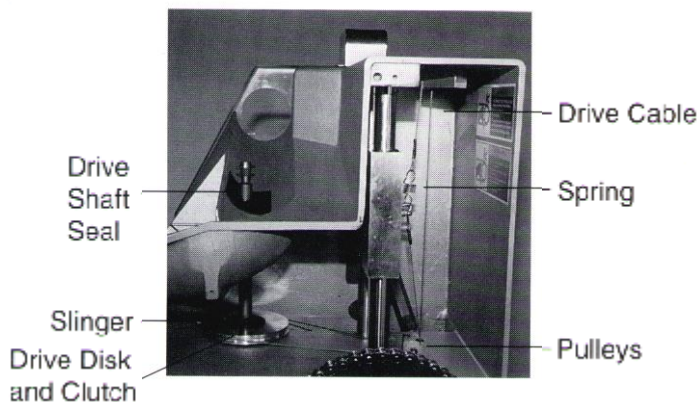
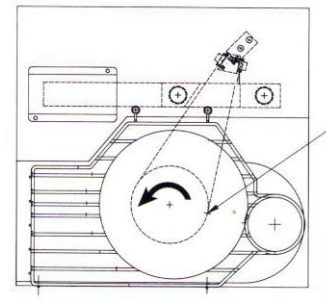

Figure 8a.



Top View Figure 8b.

Adjust so that when arm is at top of stroke, collar on cable engages slot in disk at tangent point here. Hopper rotates as shown on upstroke.

7. Check drive area for cleanliness.

If any peel and or water is in rear of Citrus Juicer, find and repair leak. If any of the splash guards need replaced, see rebuilding section.



Troubleshooting-Operator

**CAUTION: NEVER REACH INTO MOVING PARTS TO CLEAR A JAM,
NO MATTER HOW SIMPLE IT SEEMS.**

Citrus Juicer will not start.

1. Citrus Juicer is not plugged into electrical outlet.
2. Building circuit breaker has tripped.
3. Juicing area door not closed. Optional counter top waste container not properly installed.
4. Citrus Juicer is jammed.
Call for service.
5. "ON-OFF" switch is defective.
Call for service.
6. One or more covers have a defective interlock switch.
Turn off Citrus Juicer. Call for service.
7. Overloaded circuit.
Citrus Juicer needs to be on separate (own) electrical outlet.
8. Low voltage to machine.
Use 110 volts minimum.

Citrus Juicer starts, but shuts off.

1. Building circuit breaker is not properly rated.
2. Extension cord or wiring is too long.
**Shorten extension cord or use heavier gauge wire.
(See page 6, "Electrical Specifications")**
3. All covers are not completely closed.
Close any open covers.

Citrus Juicer runs with covers open or off.

1. **Turn off Citrus Juicer. Call for service.**



Troubleshooting-Operator

Citrus Juicer stalls trying to squeeze a fruit.

NOTE: Do not continue to process fruit if juicer is stalling more than once per case.

1. Fruit has part of stem on it.
Turn off Citrus Juicer. Remove fruit from Citrus Juicer and restart.
2. Peel is too thick.
Turn off Citrus Juicer. Remove fruit from Citrus Juicer and restart.
3. Cutter is damaged.
Sharpen or replace cutter as specified on page 17.

Citrus Juicer emits a "squealing" sound during operation.

1. **Turn off Citrus Juicer. Call for service.**

Low Juice Yield.

Excessive juice splattering during juicing operation.

1. Fruit is rotten or fruit stems are pulled.
Remove unsuitable fruit.
2. Orifice tube is damaged.
See page 18 to determine if it needs replacement.
3. Strainer tube is plugged.
Clean strainer tube. See page 15.



Troubleshooting-Operator

Fruit is being chopped instead of juiced.

1. Fruit is too large for Citrus Juicer.
Turn off Citrus Juicer. Remove oversized fruit. Maximum diameter is 3-1/4".
2. Fruit feeder is sticky or unclean.
**Turn off Citrus Juicer. Remove fruit.
Clean fruit lift.**
3. Citrus Juicer not level. Locate Citrus Juicer on level surface.

Fruit is fed two at a time.

1. Fruit is too small for Citrus Juicer.
Turn off Citrus Juicer. Remove undersized fruit. Minimum diameter is 2-1/2".

Fruit is not fed during every cycle.

1. The optional hopper mechanism is designed to put fruit into a single file and to break-up bridging before feeding. When hopper is full, it sometimes takes a couple of cycles to begin feeding. Large or out of round fruit sometimes do not feed well.

Cutter is constantly being damaged.

1. Red protective cap is not being placed on cutter prior to removing juice manifold and during handling.
2. Juice manifold is not secure.

Be sure spring hold-downs on lower cup are properly engaged.



Troubleshooting-Service

Citrus Juicer will not start.

1. Citrus Juicer is not plugged into electrical outlet.
2. Building circuit breaker has tripped.
3. Juicing area door not closed and locked.
4. Optional waste container not in place or pushed all the way in.
5. Buzzing sound comes from on/off switch.
Juicer needs to be on a separate (its own) electrical circuit with a minimum of 100 volts supply.
6. On/Off switch holds in the "On" position with a humming noise coming from motor.
Capacitor needs replaced. It is located in motor junction box.
7. Defective interlock switch or on/off switch.

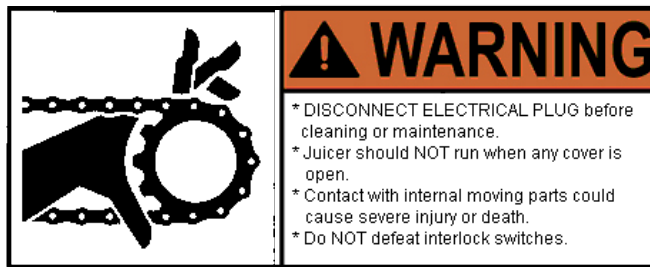

- a. **Remove the front cover protecting electrical box and motor. Remove electrical box cover with on-off switch. Refer to Figure 9.**

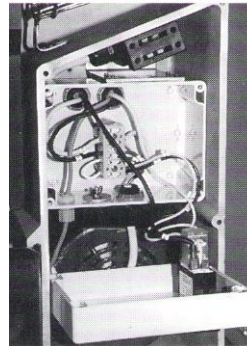

Figure 9. Electrical Box

- b. **Check continuity across each switch. Refer to Figure 10a. and 10b.**
Using a meter, check each switch individually. Check by opening and closing door cover & optional waste container. Replace defective switches.
8. Defective on/off switch or motor.
Replace on/off switch first. (Make sure interlock switches are operating properly). If this does not solve problem replace entire gear motor.

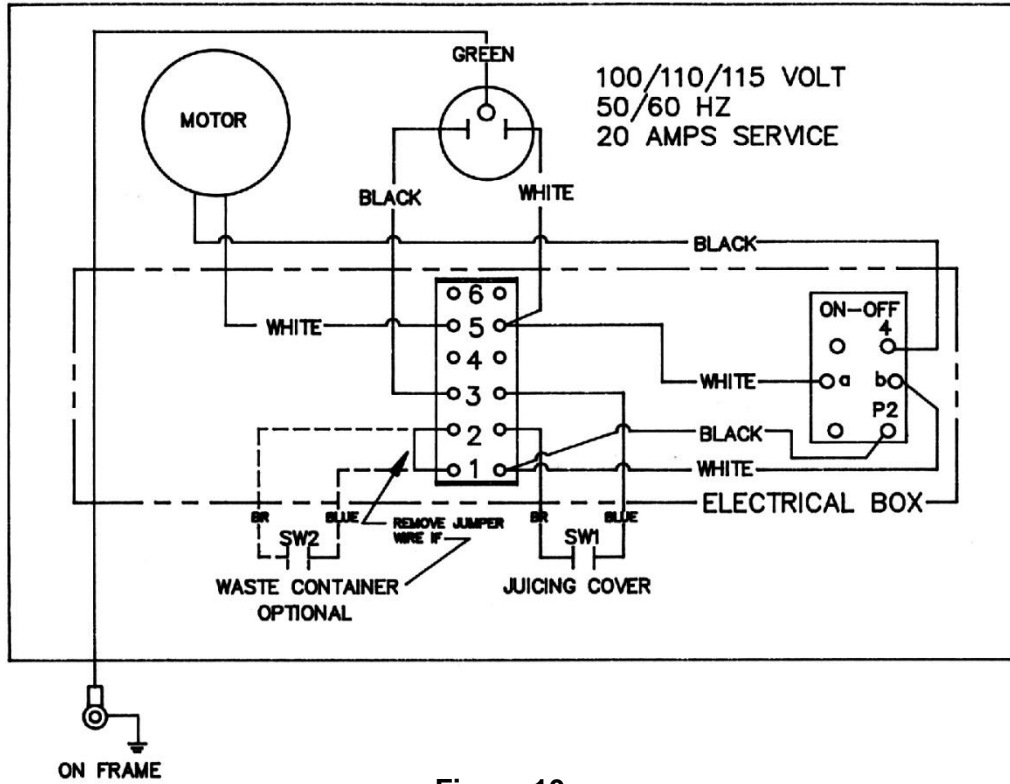

Figure 10a.

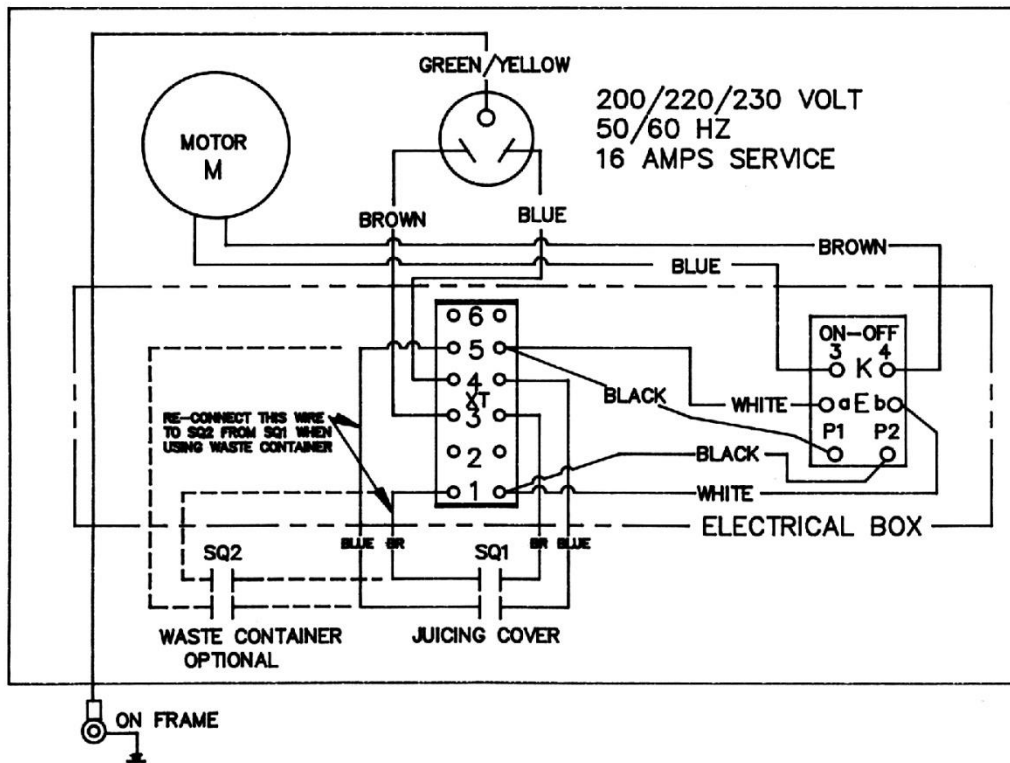

Figure 10b.



Troubleshooting-Service

Citrus Juicer emits a "squealing" sound during operation.

1. Rod end, rotary, or linear bearings need lubrication. See Periodic Inspection item 5, page 20.
2. Rod end, rotary, or linear bearings need replaced. See rebuilding.

Hopper disk does not rotate.

Note that disk operates in intermittent motion and only rotates on the up stroke of juicer.

1. Drive cable has come off one of the pulleys.
Refer to Figure 8a., 8b. on page 20.
 - a. **Remove back cover. Use spanner (snake eyes) security tool to loosen captive screws.**
 - b. **Drive cable should be adjusted with light spring tension. Make sure drive cable is wrapped per Figure 8a, 8b, and adjust if necessary.**
2. Drive clutch is worn.
Replace clutch by loosening set collar on drive shaft, unhooking drive cable and lifting shaft out of drive disk. Press new clutch into drive disk making sure disk is driven in counter-clockwise direction. (Rotates on the up stroke of the juicer).

Hopper disk rotates in both directions.

1. Clutch is rusted or frozen.
Refer to figure 8.
Pry up slinger and spray with a lubricant, rotate by hand to loosen. If still frozen, replace as described under "drive clutch is worn". After replacing, make sure slinger is lubricated with a light coat of grease and pressed all the way down on drive disk.

Rebuilding

It is best to replace all bearings at the same time.

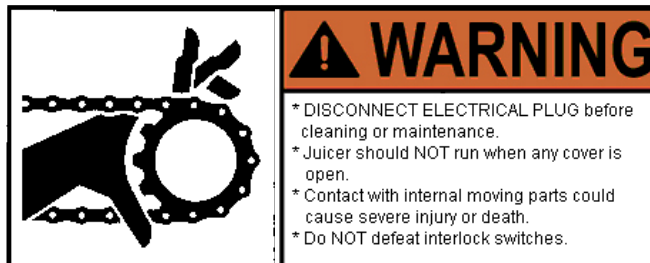

Step-by-Step instructions for replacing all bearings and rod ends.

- 1. Remove all juicing components.**
Refer to Figure 2, page 14.
- 2. Remove fruit lift.**
Remove 1/4-20 x 3" hex head cap screws.
- 3. Remove splash guards in juicing area.**
Refer to Figure 11.

Use knife to cut away Silicone from plastic splash guards and drive arms. If necessary, use hand crank adapter on motor sprocket with 1/2" drive ratchet to rotate Citrus Juicer into position to pull off splash guards. Remove upper cup spring, upper splash guard. Remove clip that holds lower splash guard in place.

- 4. Remove back cover**
Use spanner (snake eyes) security tool to loosen captive screws.
Refer to figure 12.

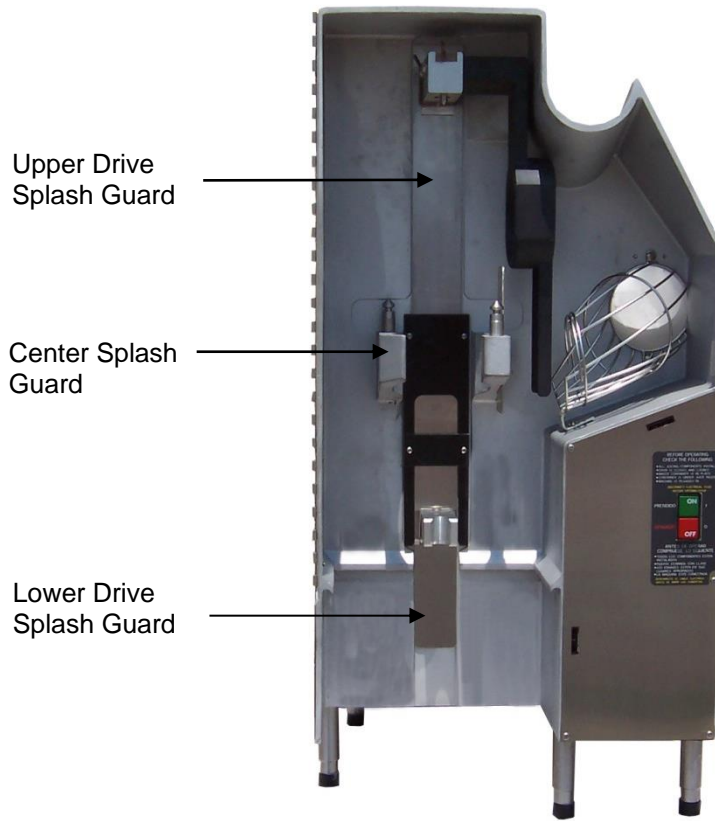

Figure 11. Front View of Citrus Juicer

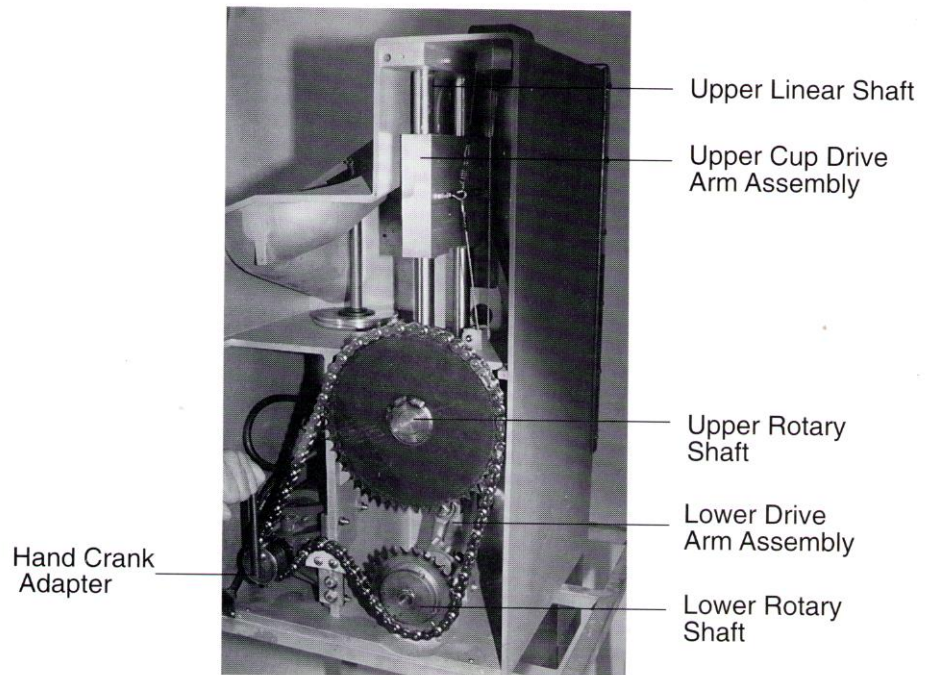

Figure 12. Back View of Citrus Juicer

Rebuilding

5. **Rotate drive so upper cup drive is in the down position.**
Remove chain, spring clip type master link.
Be careful - drive arms may move as chain is removed.
Remove large sprocket. Use a 9/16" socket and a 3/16" Allen wrench.
6. **From the back use a 9/16" wrench or socket to loosen hex head cap screw on crank arm for upper cup drive.**
NOTE: If just replacing rod ends on upper cup drive assembly, use access hole under center splash guard to remove left hand cap screw from crank arm.
Use a 3/16" Allen wrench to loosen set screw on keyway. Back screws out at least 1/4" to clear flats on shafts.
Refer to Figure 13.

From the back repeat above steps on crank arm for lower drive.
Refer to Figure 14.
7. **Remove lower drive sprocket with shaft still connected.**
Remove upper drive shaft.
Refer to Figure 15.

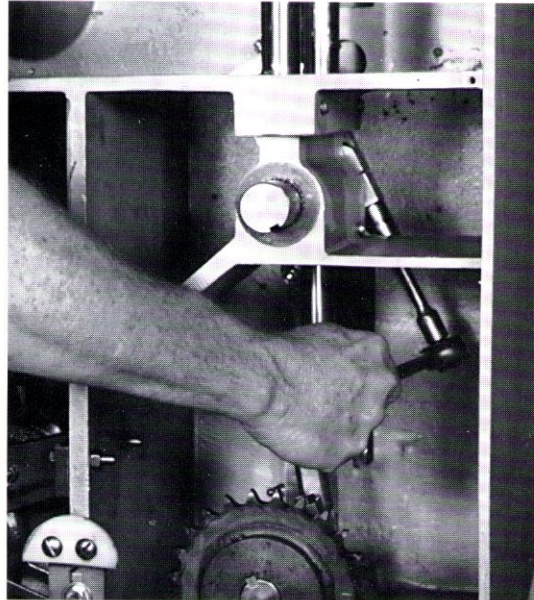

Figure 13. Using Socket to Loosen Upper Cup Crank Arm

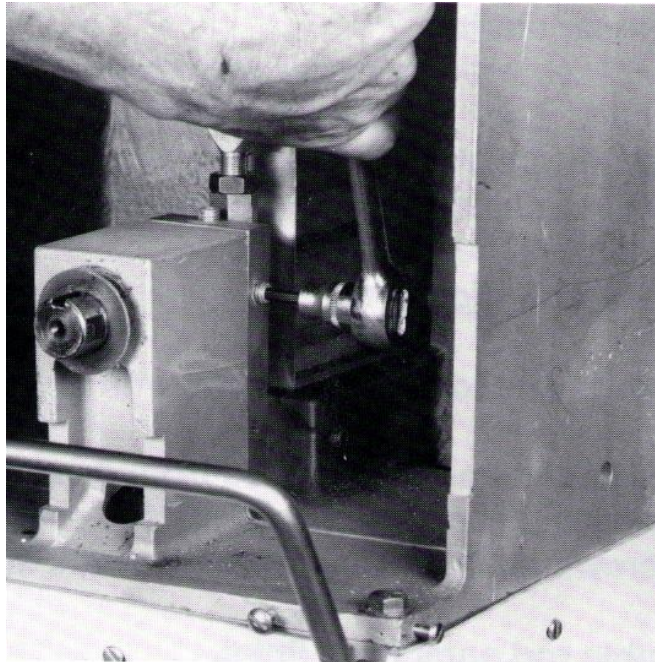

Figure 14. Loosening Lower Crank Arm

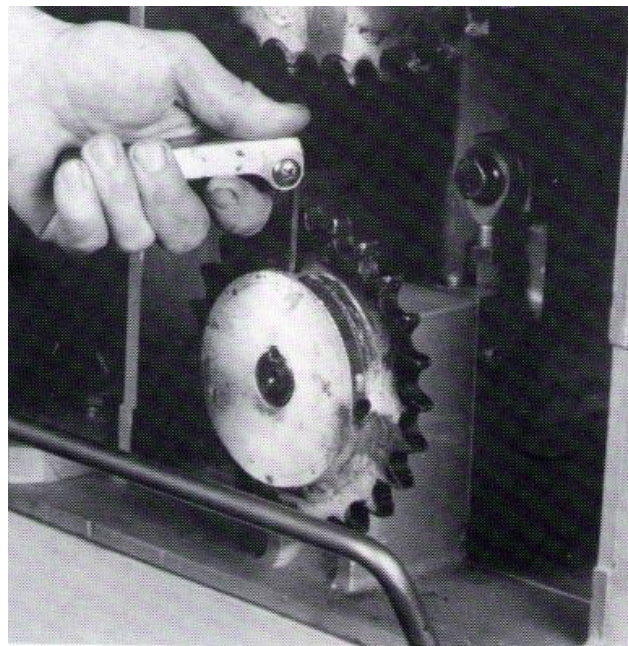

Figure 15. Sprocket with Shaft being Removed

Rebuilding

8. Remove linear shafts.

With a 3/16" Allen wrench, loosen setscrews at top and bottom of all three shafts. Back screws out at least 1/4" to clear flats on shafts. If shafts are stuck, use bearing removal puller with 3/8"-16 x 2" hex head cap screw to break free shafts. NOTE: Lower shaft comes out of bottom of Citrus Juicer.

Refer to figure 16.

9. Lift out upper and lower drive arms with linkages still attached.

10. Disassemble rod end assemblies from drive and crank arms.

Note location and numbers of washers and spacers.

NOTE: Screws and rod ends on both crank arms are left-hand threads.

11. Disassemble rod ends from links.

Re-assemble with new rod ends (**Refer to Figures 17 and 18**), using rod end adjustment bar with the appropriate rod and tooling washer. Remember one end is a left-handed thread.

Wrenches required are 3/4", 7/8" and 15/16".

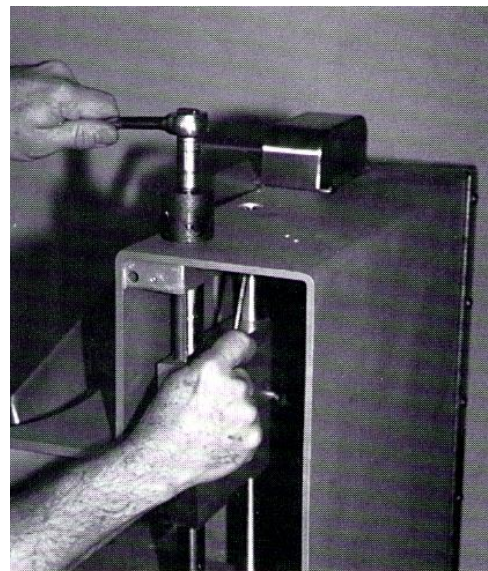
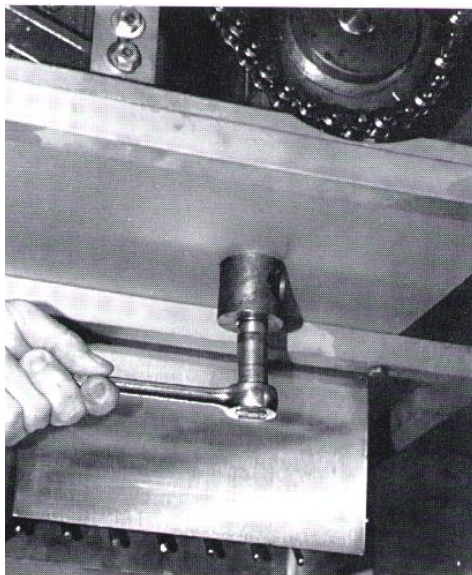

Figure 16. Removal of Linear Shafts with Puller

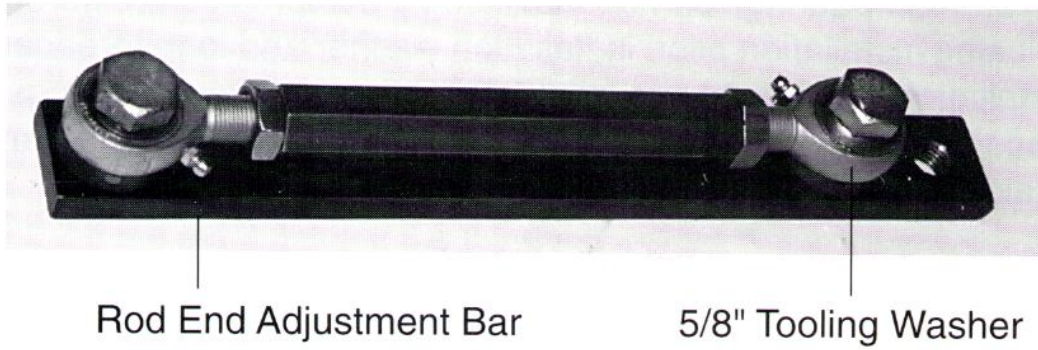

Figure 17. Assembly of 5/8" Rod Ends

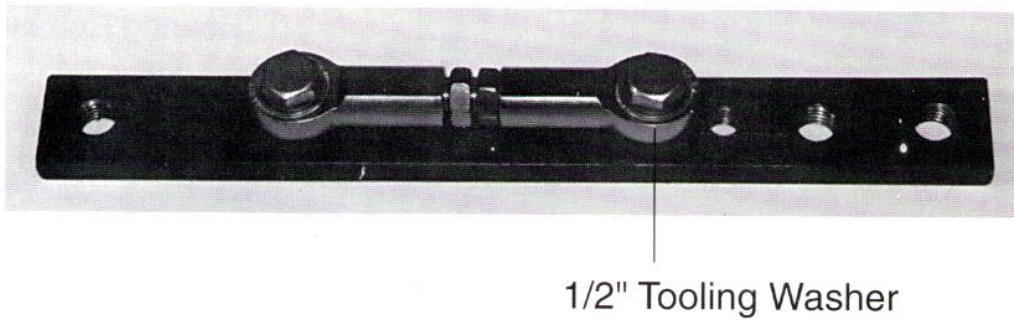

Figure 18. Assembly of 1/2" Rod Ends

Rebuilding

12. Remove sleeve bearings from upper and lower drive arms. Refer to figures 19a., 19b. and 20.

Bearings can be pulled out using puller, 1" removal slug, and short threaded removal rod; or can be driven or pressed out using driver. New bearings can be installed by compression (**Figure 21**) by using installation pilot, installation washer and long threaded installation rod, or just use installation pilot and press bearings into place. Light coat of Teflon grease can be used on O.D. of bearings to aid in installation.

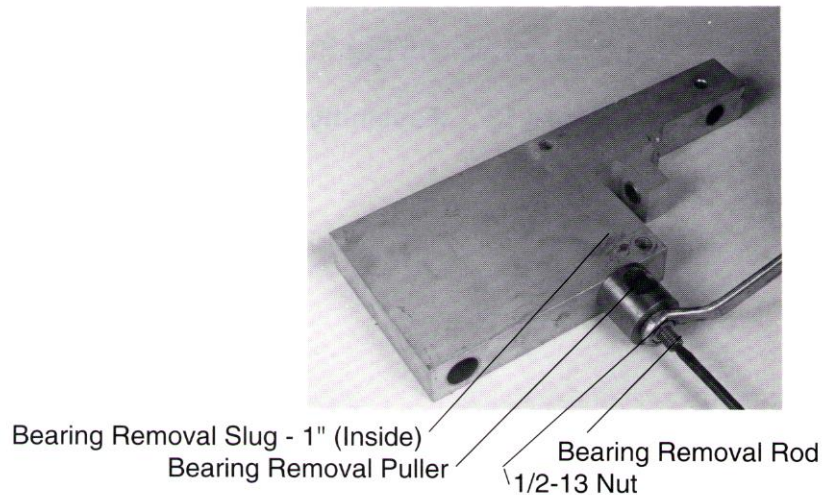

Figure 19a. Remove Bearings from Upper Drive Arm

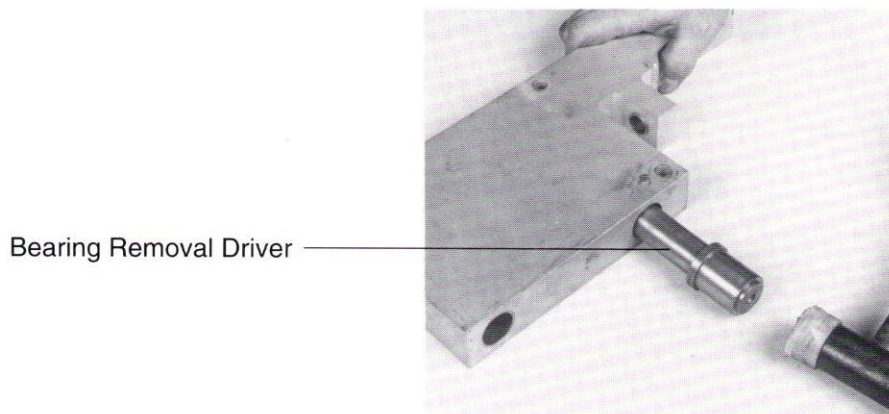

Figure 19b.

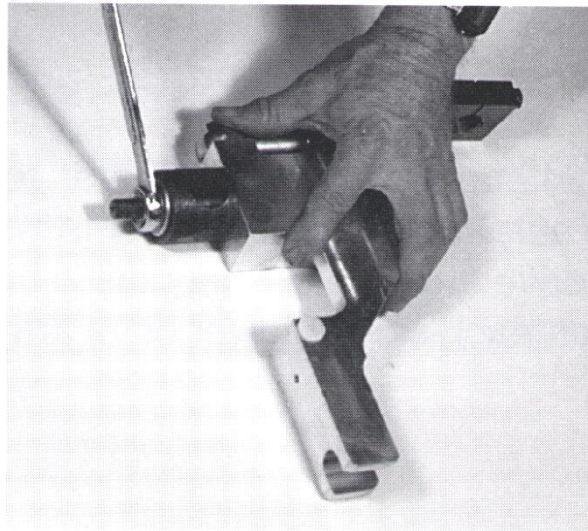

Figure 20. Removing Bearings from Lower Drive Arm

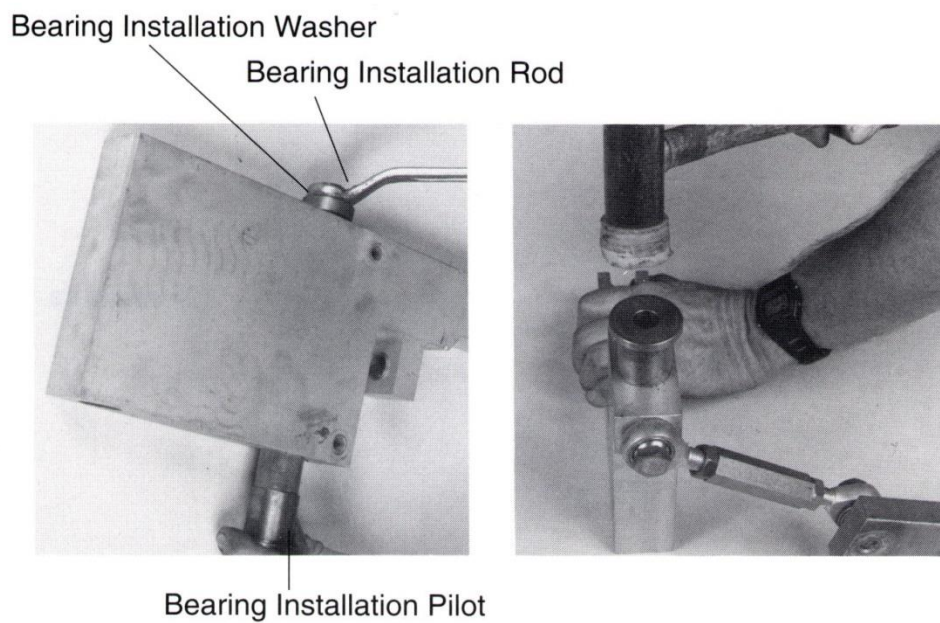

Figure 21. Installation of Bearings into Drive Arms

Rebuilding

13. Re-assemble rod end assemblies to drive arms, again making sure left-hand threaded ends are on the crank arms. Refer to Figures 22 and 23.

Use Loctite #242 on all fasteners. Tighten to torques as shown. Make sure rod end lock spacer is installed on rod end in upper drive arm. Make sure plastic bearing buttons are installed on each side of lower drive arm.

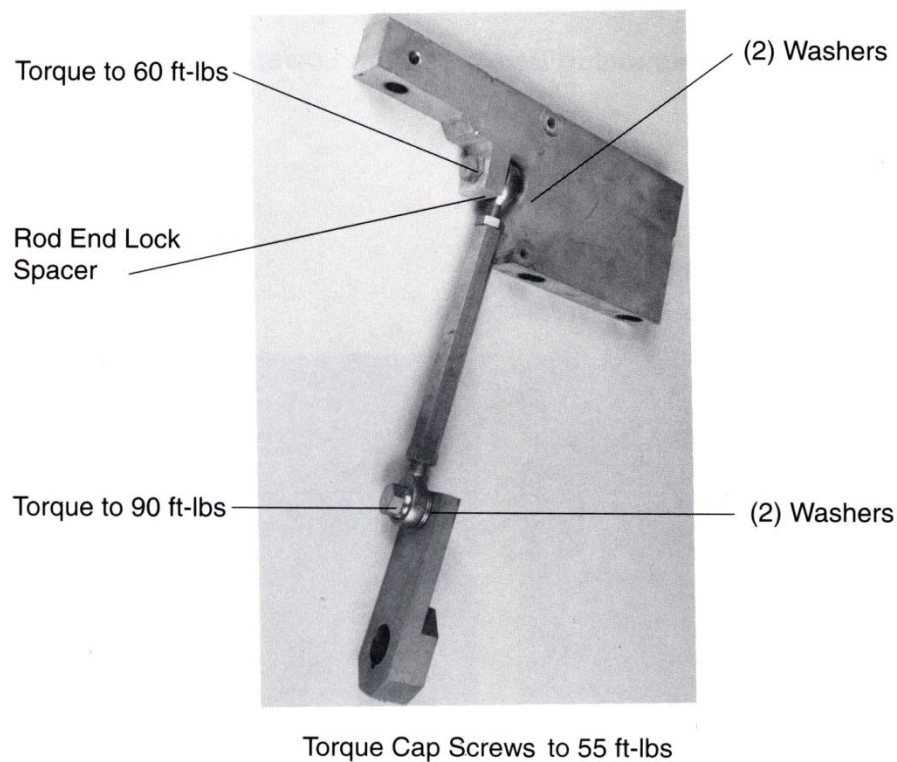

Figure 22. Completed Assembly of Upper Cup Drive Arm

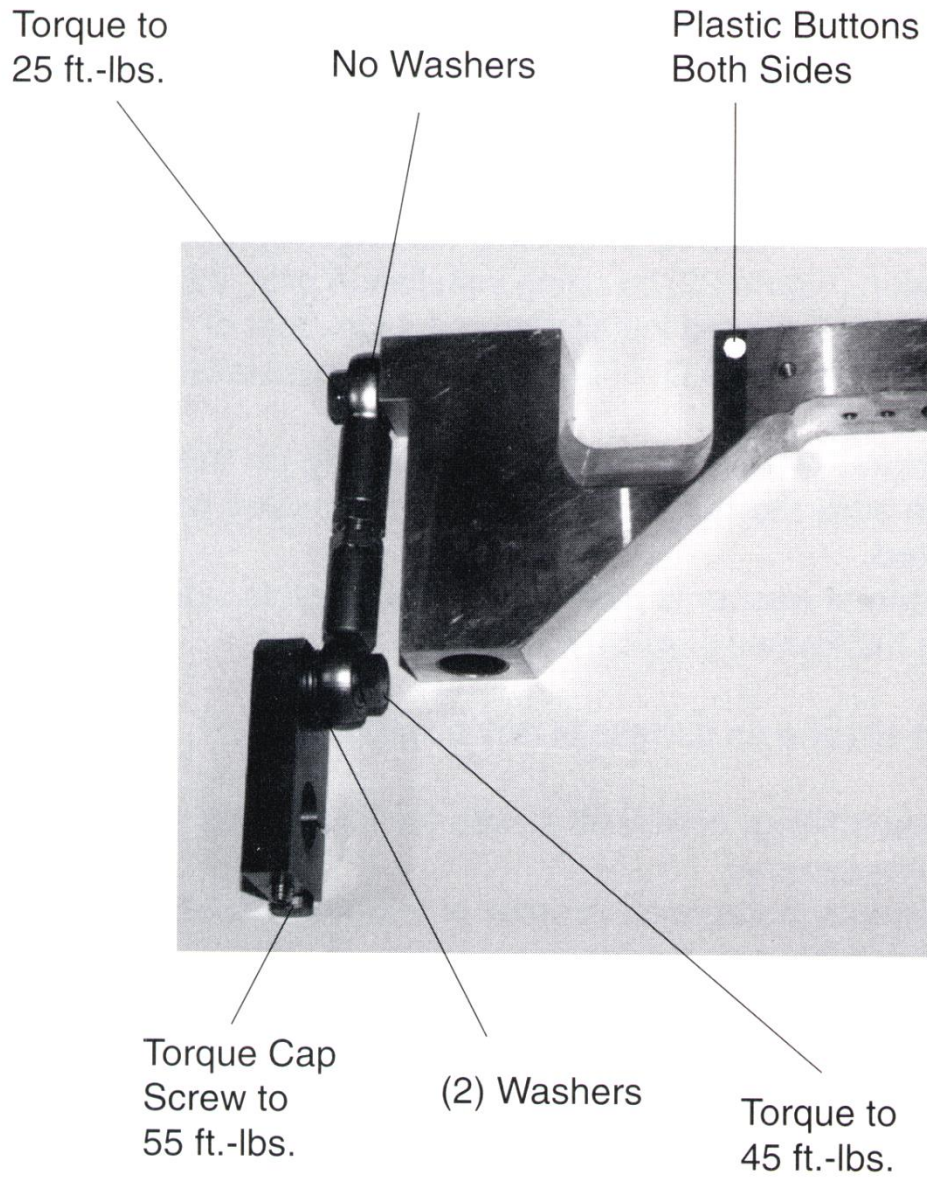

Figure 23. Completed Assembly of Lower Drive Arm

Rebuilding

14. **Remove sleeve bearings from main frame. Refer to Figures 24 and 25.**

The outer upper drive shaft bearing can be removed using puller, 1-1/4" removal slug, and short threaded removal rod. The inner bearing can be removed the same way, or can be pressed out using driver. The lower shaft bearings can be removed the same way except using 1" removal slug. New bearings can be installed by compression (**Figure 26**) by using installation pilot, installation washer, and long threaded installation rod. Light coat of Teflon grease can be used on O.D. of bearings to aid in installation.

15. **There are thrust washers next to each bearing on the main frame. Make sure the old ones have been removed and new ones installed.**

One side of thrust washer is plain metal. Silicone this side and glue them to the frames (Typical 4 places).

DO NOT get silicone on surface of any bearing.

16. **Before re-assembling, check all shafts for excessive wear; replace as necessary.**

Re-assemble parts in the reverse order of removal. **DO NOT** forget to put keys back into crank arms.

Tighten fasteners to torques shown.

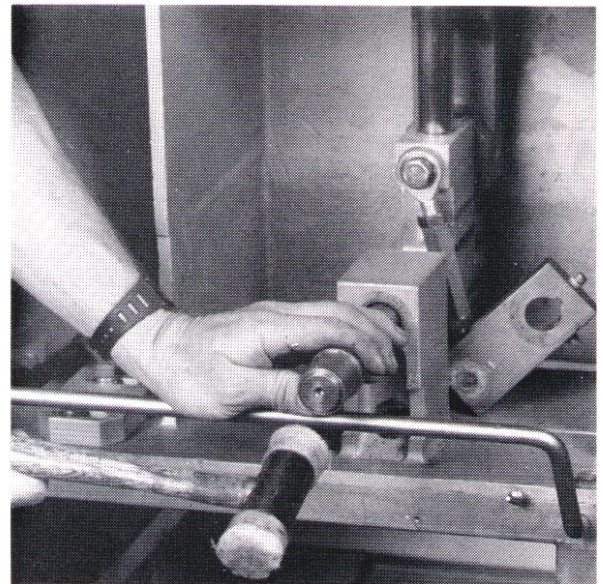
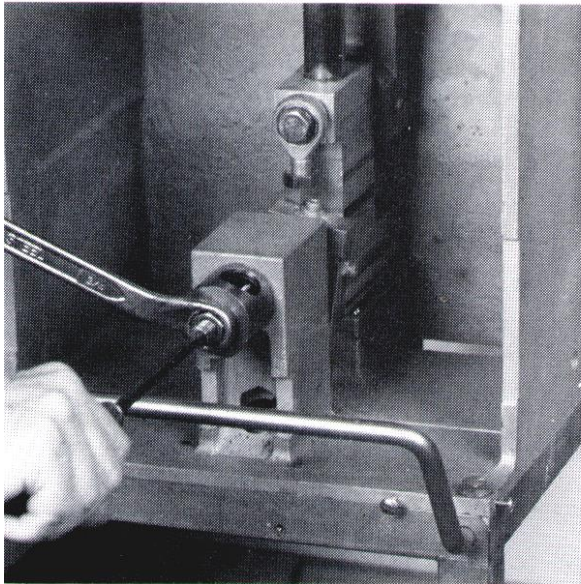
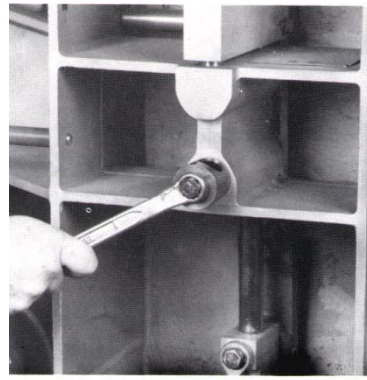
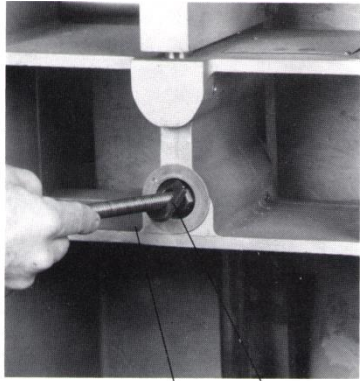
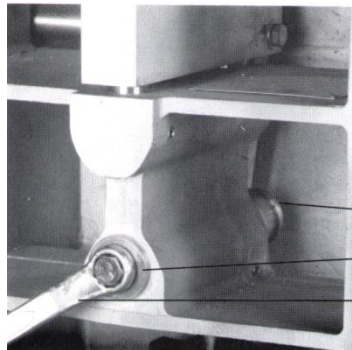

Figure 24. Removing Bearing from Lower Rotary Drive



Bearing Removal Rod
Bearing Removal Slug

Figure 25.
Removing Bearings
from Upper Rotary Drive



Installation Pilot
Installation Washer
Bearing Installation Rod

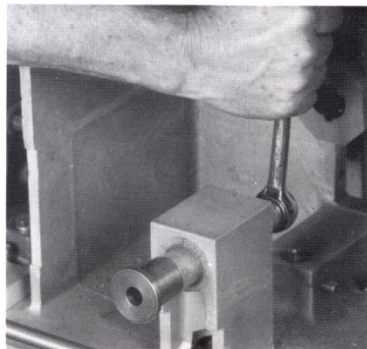
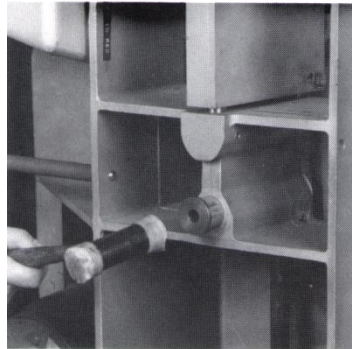

Figure 26. Installation of Bearings and Thrust Washers

Rebuilding

17. **Before installing chain, align timing marks as shown. Refer to figure 27.**

This is critical to operation of the machine. Adjust chain as shown in Periodic Inspection section.

18. **To check to see if upper cup crank rod end link needs to be adjusted, install juice manifold, upper and lower cup. Refer to Figure 28.**

Using hand crank adapter, gently rotate until upper cup drive is in the full down position. **DO NOT** force it, if it appears to be binding, readjust rod end link. If it rotates freely past bottom position, check for too much clearance. In the full down position, release spring on upper cup. Cup should not drop down; if it does, readjust rod end link.

Cups should just meet – no clearance – no bind.

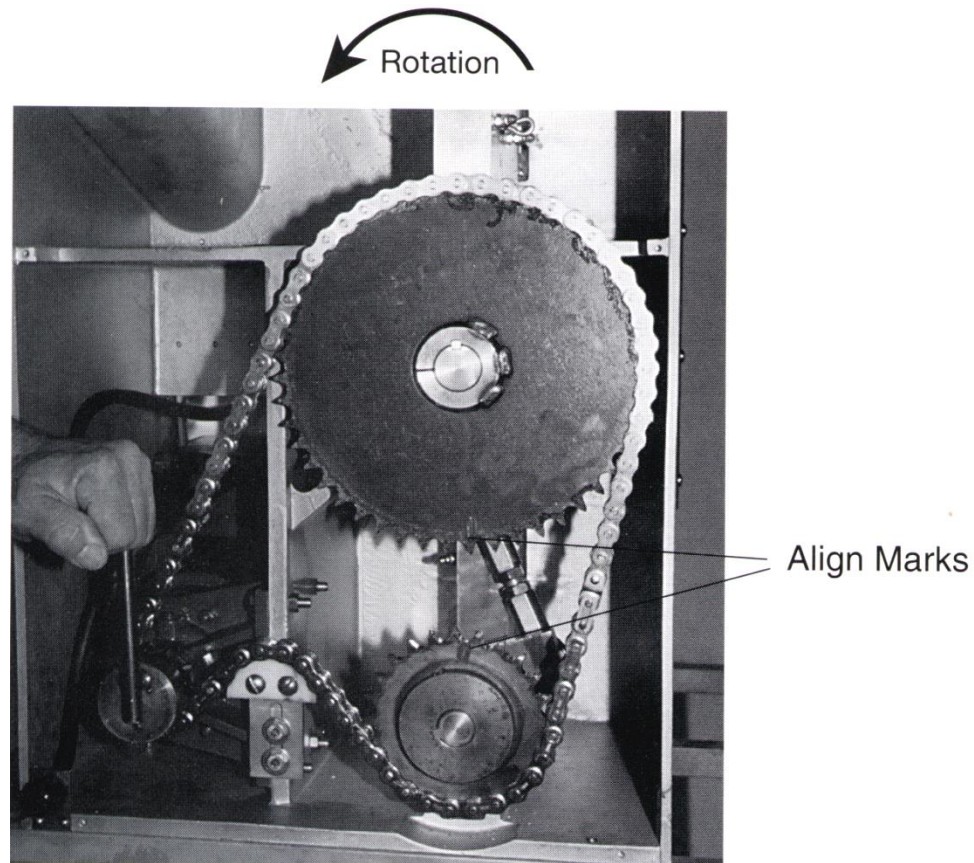

Figure 27. Align Timing Marks

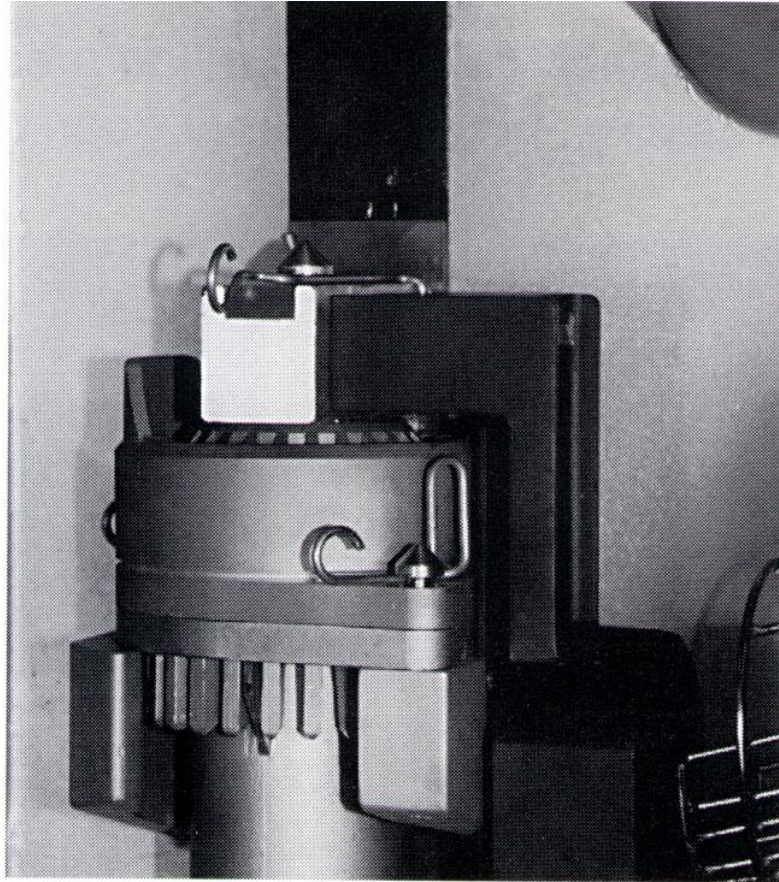

Figure 28. Checking for Cup Clearance

Rebuilding

19. Remove juicing components and install the upper drive splash guard (groove goes down and in) and upper cup spring onto drive arm.
Refer to Figure 29.

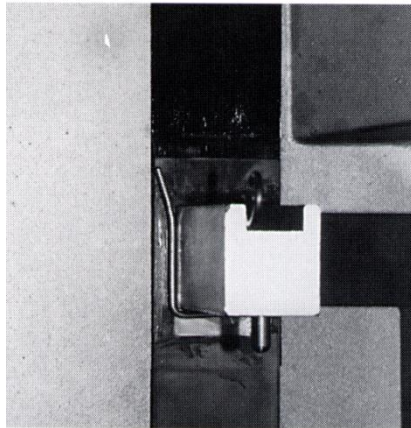

Figure 29. Installation of Upper Splash Guards

20. **Install lower splash guard.**
Be sure "up" stamped on part faces up, and guard is flat against wall. Seal with RTV.737 silicone, and install clip.
Refer to Figure 30a.
21. **Install Center Splash Guard**
Chamfer goes up and to the left. Rotate Citrus Juicer with hand crank to make sure all splash guards are operating properly.

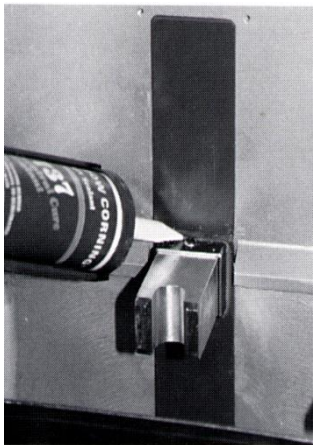

Figure 30a. Installing Lower Splash Guards

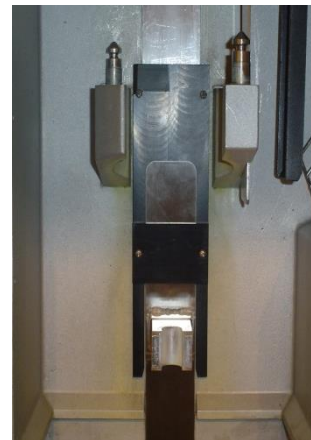

Figure 30b. Installing Center Splash Guard.



Rebuild Tooling Kit **060-00202**

<u>Item</u>	<u>Part Number</u>	<u>Description</u>
1	060-00180-B	Tool, FNS, Bearing Pilot Install
2	060-00181-B	Tool, FNS, Bearing Washer Install
3	060-00182-B	Tool, FNS, Bearing Puller
4	060-00183-B	Tool, FNS, Bearing Slug 1"
5	060-00184-B	Tool, FNS, Bearing Slug 1-1/4"
6	060-00185-B	Tool, FNS, Bearing Driver Remove
7	060-00186-B	Tool, FNS, Rod, Bearing Install
8	060-00187-B	Tool, FNS, Rod, Bearing Removal
9	060-00188-B	Tool, FNS, Washer, Rod End 1/2"
10	060-00189-B	Tool, FNS, Washer, Rod End 5/8"
11	060-00190-B	Tool, FNS, Bar, Rod End Adjust
12	060-00191-B	Tool, MFJ, Adapter, Hand Crank
12a	060-02120-B	Tool, CJ, Adaptor, Hand Crank
13	004-350-648	Screw, MFJ, Cap, Hex, 5/8-11 x 1-1/2" Lg
14	004-350-571	Screw, MFJ, Cap, Hex, Full Thread
15	004-110-063	Nut, MFJ, Hex, 1/2-13, Grade 8 Steel
16	004-815-100	Washer, Plain Narrow, 1/2"
17	004-815-080	Washer, MFJ, Plain Narrow, 3/8", C/G
18	004-350-407	Screw, MFJ, Cap, Hex, 3/8"-16 x 2" Lg, C/G
20	009-998-004	Bit, Spanner Insert, #8 1/4" hex

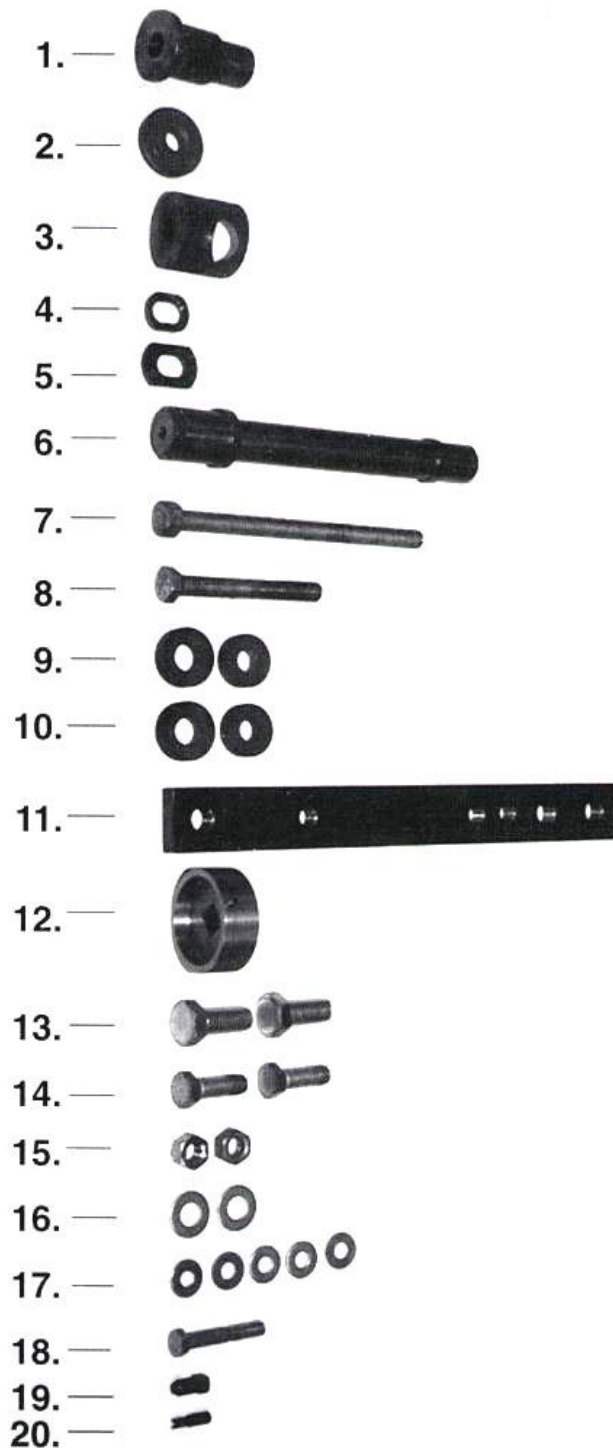

Figure 31. Rebuild Kit



Drive Parts 060-02002

<u>Item</u>	<u>Part Number</u>	<u>Qty</u>	<u>Description</u>
1	060-02007-R	1	Main Frame Machining
2	005-576-061	1	Key, Sq, 1/4" x 3/4" Lg
3	005-576-242	1	Key, Sq, 1/4" x 1" Lg
4	007-120-205	5	Fitting, Grease 1/4-28 x 45°
5	060-02043	1	Pin, Cup Locator
6	005-576-223	1	Key, Sq, 3/16" x 1", SS
7	060-02016	1	Arm, Drive , Upper Cup (Includes (4) item 45 & (2) Item 4)
8	004-352-661	1	Screw, Cap, Hex, 5/8-11 x 2-1/2" Lg, SS
9	060-00057	1	Rod End Lock
10	060-02060	1	Rod End, Upper Assembly
11	004-816-120	4	Washer, Plain, 5/8, Narrow, SS
12	060-00078	1	Screw, L. H.
13	060-02027	1	Crank, Upper Cup Drive, 5-5/8" Lg.
14	005-098-113	2	Washer, Thrust
15	060-02014	1	Arm, Drive, Orifice Tube (Includes (2) item 45 & (1) Item 4)
16	060-00068	2	Bearing, Plastic
17	060-02046	1	Sprocket, 50B48, 1-1/4 Bore
18	060-02017	2	Shaft, Upper Linear
19	004-352-571	1	Screw, Cap Hex, 1/2-13 x 1-1/2" Lg, SS
20	060-00062	1	Rotary Main Drive Shaft
21	060-02061	1	Rod End, Lower Assy. (Includes Items 21a through 21c)
22	005-576-249	1	Key, Sq, 1/4" x 1-1/2" Lg, SS
23	004-352-572	1	Screw, Cap Hex, 1/2-13 L.H. x 1-1/2" Lg, SS
24	004-816-100	2	Washer, Plain, 1/2, Narrow, SS
25	060-02015	1	Shaft, Lower Linear
26	005-098-112	2	Washer, Thrust
27	060-02047	1	Sprocket, 50B24, 1BKWSS
28	005-576-246	1	Key, Sq, 1/4" x 1-1/4" Lg, SS
29	060-00061	1	Shaft, Rotary Orifice Drive, 4-7/8" Lg
30	004-350-212	1	Screw, Cap Hex, 3/8-16 x 1-3/4" Lg, Grade 8, S/L
31	004-352-327	4	Screw, Cap Hex, 5/16-18 x 1-1/2" Lg, SS
34	060-02005	1	Electrical Subassembly
35	005-245-024	1	Chain, #50 x 50-5/8 Lg. (81 Links) W/ Half Link & Master Link
36	004-816-070	8	Washer, Plain, 5/16", Narrow, SS
37	005-804-216	1	Sprocket, 50B15, 3/4BKWSS, 13 Strokes/Minute
37	005-804-063	1	Sprocket, 50B14, 3/4BKWSS, 10 Strokes/Minute (220V/50 Hz Only)
38	004-111-040	4	Nut, 5/16-18, SS
41	004-541-138	11	Screw, Set Socket, Cup Point, 3/8-16 x 3/4" Lg, S/L, SS
42	060-02026	1	Orifice Tube Crank
44	004-450-050	2	Screw, Set Socket, 1/4-20 x 1-1/2" Lg, S/L, 18-8
45	060-10192	1	Chain Tensioner Assembly
46	060-10193	1	Chain Guide
47	060-10170	1	Chain Tensioner Bracket
48	004-401-073	4	Screw, Truss Head, 1/4-20 x 1" Lg, SS
49	004-356-088	2	Screw, Cap, Socket, 5/16-18 x 1" Lg, SS
50	004-352-241	2	Screw, Cap, Hex Head, 1/4-20 x 1" Lg, SS
51	004-116-015	2	Nut, Hex, Jam, 1/4-20, SS

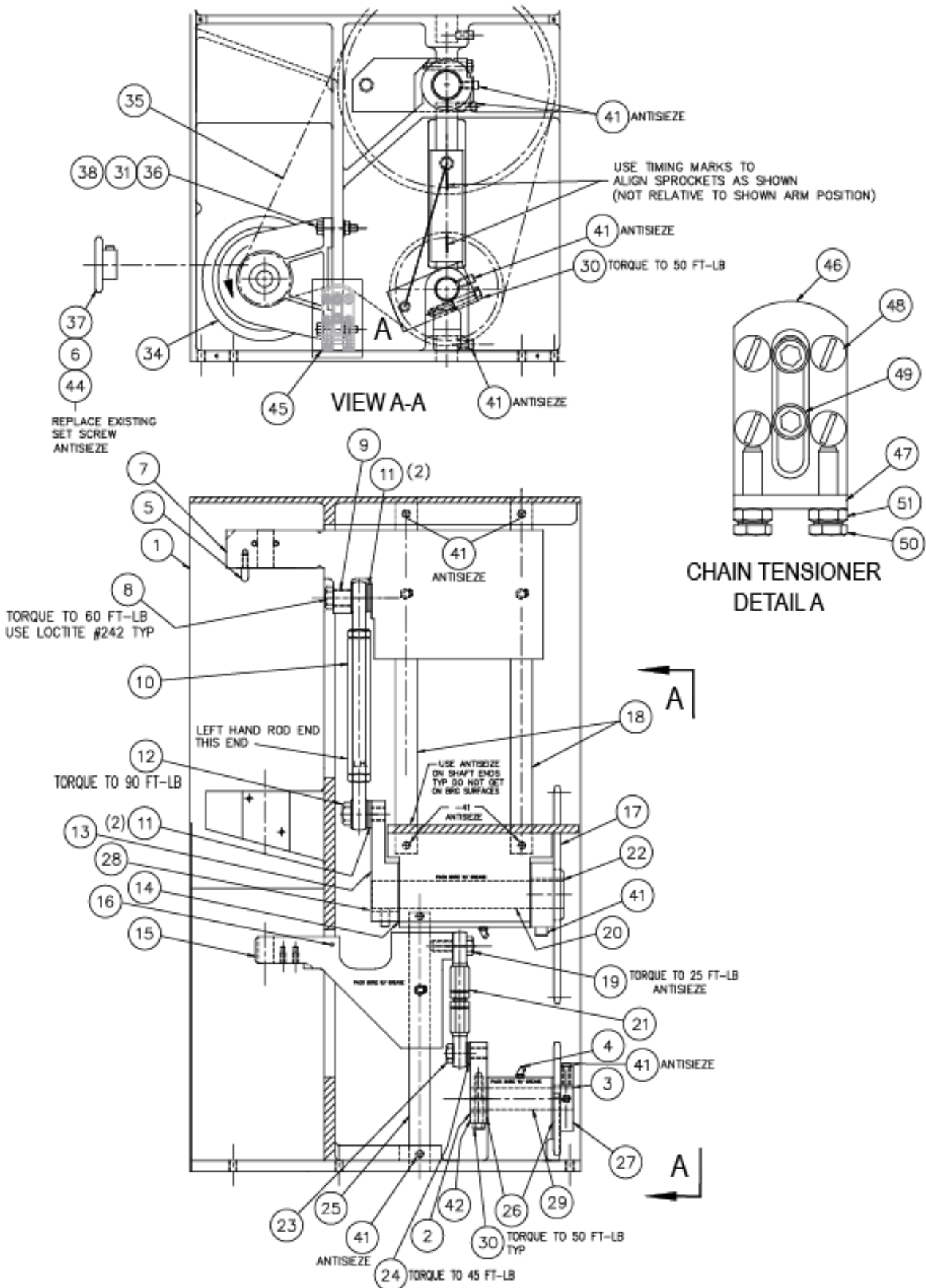

Figure 32. Drive Parts



Juicing Parts 060-02000

<u>Item</u>	<u>Part Number</u>	<u>Qty</u>	<u>Description</u>
1	060-02003	1	Cover Assembly (See Page 58 for Detail)
2	060-02022	1	Tube, Strainer, CJ, 0.033
2	060-02088	1	Tube, Strainer, CJ, 0.040
2	060-02089	1	Tube, Strainer, CJ, 0.055
3	060-02034	1	Nozzle, Short, 4-3/4" Lg
3	060-02130	1	Nozzle, Long, 8-3/4" Lg
3	060-02310	1	Nozzle, Straight (CFA)
4	060-02038	1	Tube, Orifice, CJ
5	060-00225	1	Cutter & Knives, MFJ & CJ
6	060-02062	1	Cup Assembly, Upper (Includes Item 6a)
6a	060-02020	1	Pin, Upper Cup
7	060-02063	1	Cup Assembly, Lower (Consists of Items 7a, 7b and 7c)
7a	060-02031	1	Spring, Cup, Lower
7b	060-02009	1	Cup, Lower
7c	004-380-014	2	Screw, Fillester Head, 10-24 x 5/16" Lg slotted, SS
8	06-002013	1	Manifold, Juice
14	004-406-003	1	Screw, Mach Round Head, # 4-40 x 3/16" Lg, SS
15	009-092-018	1	Cap, Cover (Not Shown)
16	007-132-143	1	Down Spout Nozzle
18	007-486-132	1	O-Ring, Nozzle, CJ
Options			
21	060-02231	1	Waste Container Assembly Without Legs (See Pages 64-65) 6-1/2" Deep Waste Container
21	060-02231-01	1	Waste Container Assembly With Legs (See Pages 64-65) 10-1/2" Deep Waste Container
	060-02094	1	Thru The Counter Assembly (Not Shown)
	060-02134	1	Cart Assembly, Enclosed (Not Shown)
	060-02092	1	Hopper Assembly (Not Shown)
	060-02333	1	Tube, Replacement, 3ft (Not Shown) (Use only with Item 3, 060-0231, Straight Nozzle)

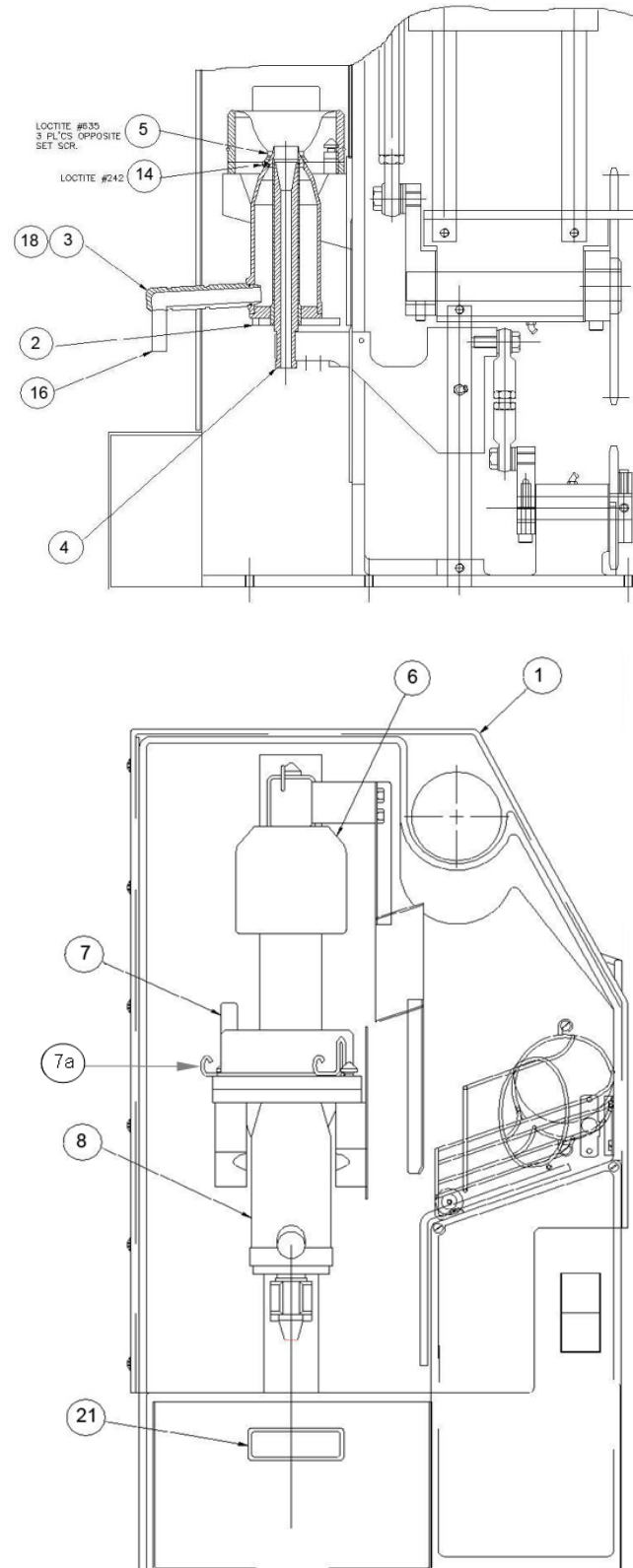

Figure 33. Juicing Parts



Cart Assembly Enclosed Parts 060-2134

<u>Item</u>	<u>Part Number</u>	<u>Qty</u>	<u>Description</u>
1	060-02117	1	Cart Frame
2	060-02053	1	Chute, Waste, Counter Top Models
3	004-401-022	6	Screw, Mach Truss, #10-24 x 3/8" Lg, SS
4	060-02132	1	Shelf
5	060-02133	1	Cart Floor
6	060-02123	1	Cart Door
7	009-080-536	2	Caster, Swivel
8	004-352-315	20	Screw, Cap Hex, 5/16-18 x 3/4" Lg, SS
9	004-816-070	20	Washer, Plain, 5/16, SS
10	004-111-040	16	Nut, Hex, 5/16-18, SS
11	009-080-535	2	Caster, Rigid
12	009-609-041	1	Plug, Brake Hole (Dust Cover)
13	004-260-017	2	Rivet, Pop, 1/8" x 1/8" Lg, SS
14	009-425-019	1	Latch, Spring
15	060-00072	2	Hinge, Female
16	060-00071	2	Hinge, Male
17	004-260-015	4	Rivet, Pop, 3/16" x 1/4" Lg, SS
18	009-092-026	1	Waste Container
19	004-111-022	8	Nut Hex, #10-24, SS
20	060-02237	1	Decal, Cleaning Instructions
21	060-00122	1	Label, Moving Juicer (Not Shown)
22	060-00175	1	Label, Moving Juicer, Spanish (Not Shown)
23	004-461-025	4	Hook, #10-24, SS
24	004-385-030	4	Screw, Fillester Head, #8-32 x 1/2" Lg, SS
25	004-111-018	4	Nut, Hex, #8-32, SS
26	003-435-020	1	Edge, Trim, Neoprene Rubber, 3/16" Opening

Jet Spray / Chiller Dispenser

<u>Item</u>	<u>Part Number</u>	<u>Qty</u>	<u>Description</u>
	060-02056	1	Dispenser, Chiller Assy (Not Shown)
	060-02057	1	Shelf, Chiller Dispenser Unit (Not Shown)
	009-120011	1	Lid, Single Walled, Chiller Dispenser (Not Shown)
	060-02265	1	Lid, Jet Spray with Tapped Hole (Not Shown)
	007-132-130	1	Fitting, Hose Adapter, , 1/2" x 3/4", Plastic (Not Shown)
	003-925-090	1	Tubing, 5/8" OD x 1/2" ID, Clear Vinyl (Not Shown)
	007-132-133	1	Elbow, Tube, Plastic, 1/2" x 3/4", White Nylon (Not Shown)

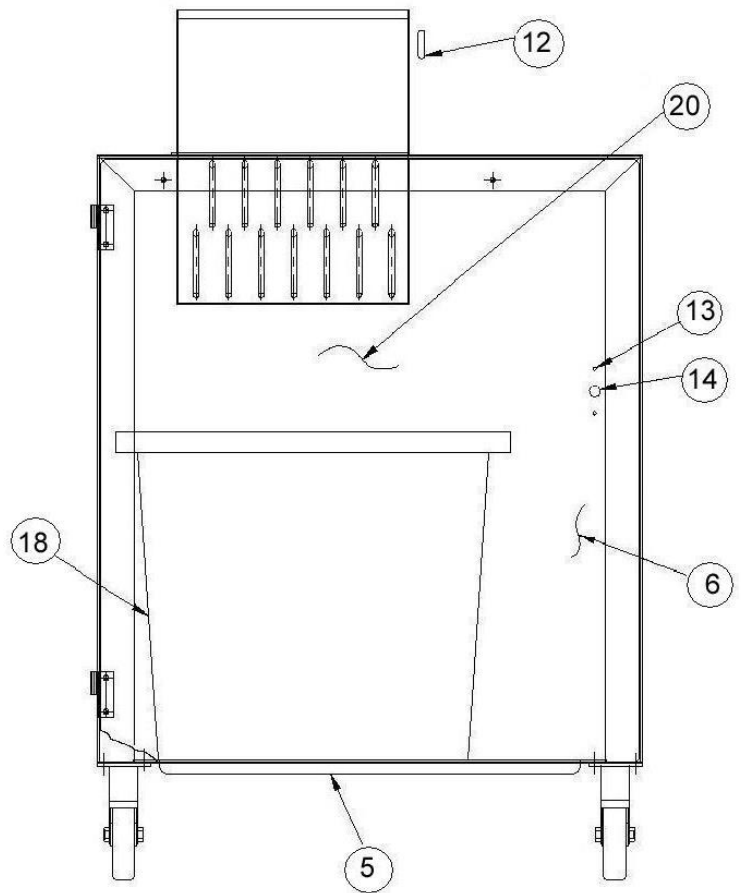
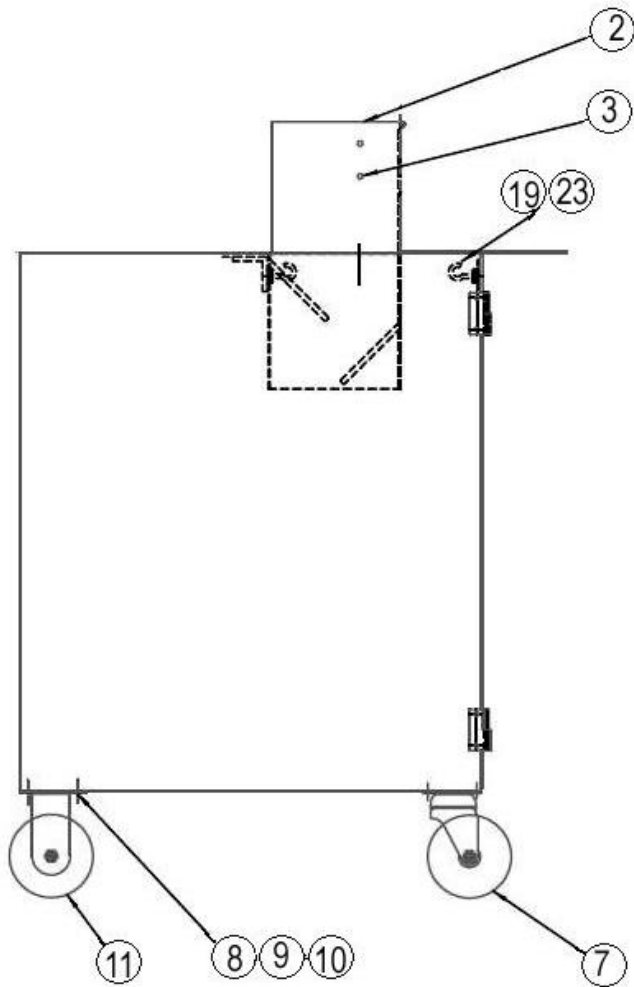
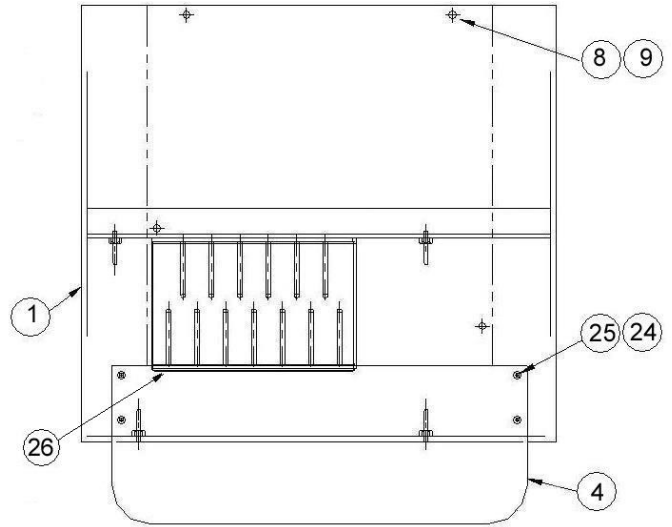
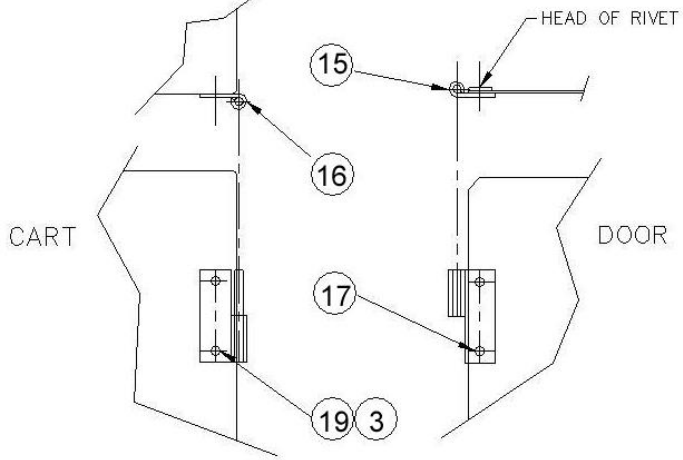

Figure 34. Cart Assembly, Enclosed



Electrical Parts (110 Volt), 060-02005

110 Volt Citrus Juicer

<u>Item</u>	<u>Part Number</u>	<u>Qty</u>	<u>Description</u>
1	060-02065	1	Holder, Cord Grip
2	060-02064	1	Motor Assembly, 110V/60 Hz (prior to 8/2013)
2	060-02266	1	Motor Assembly, 110V/60 Hz (after 8/2013) (for Motor Replacement, see below)
3	060-02041	1	Electrical Box Assembly
4	060-00096-09	1	Wire, Jumper, 16 Ga, 2" Lg (Not Shown)
5	007-143-395	1	Connector, Male, M20 x 1-1/2" Thread
6	006-220-046	1	Terminal, #10 Ring End, 10-12 Ga, Double Crimp Type
7	006-200-267	1	Switch, Safety, Schmersal
8	006-080-073	2 Ft	Cord, 14 Ga, 2 Conductor
9	006-080-071	1	Power Cord With 15A Plug, 10" Lg
10	006-060-075	1	Connector, Cord, 1/2" NPT, Straight, Flex
11	004-816-070	4	Washer, Plain, 5/16", SS
12	004-401-026	6	Screw, Mach Truss #10-24 x 5/8" Lg, SS
13	004-397-077	2	Screw, Mach Rd Slotted, #8-32 x 1/2" Lg, 304SS
14	004-352-327	4	Screw, Cap Hex, 5/16-18 x 1-1/2" Lg, SS
15	004-156-063	4	Nut, Hex, S/L, LT, 5/16-18, SS

Citrus Juicers with Waste Container Assembly

<u>Item</u>	<u>Part Number</u>	<u>Qty</u>	<u>Description</u>
16	060-02085	1	Bracket, Safety Switch
17	007-143-396	1	Fitting, Liquid Tight, Straight Strain Relief
18	007-143-395	1	Connector, Male, M20 x 1-1/2" Thread
19	006-200-268	1	Key, Safety, for 006200267 Schmersal
20	006-200-267	1	Switch, Safety, Schmersal
21	004-401-024	2	Screw Mach Truss #10-24 x 1/2" Lg, SS
22	004-401-022	2	Screw Mach Truss #10-24 x 3/8" Lg, SS
23	004-385-028	2	Screw, Mach FL, Security Type, #8-32 x 3/9" Lg, SS
21	006-080-073	1	Cord, 14 Ga, 2 Conductor x 1-1/2 Ft

Motor Replacement

For units with 060-02064 (prior to 8/2013), replacement of the motor requires a conversion kit which includes the motor, conversion plate and associated hardware:

<u>Item</u>	<u>Part Number</u>	<u>Qty</u>	<u>Description</u>
	060-10157	1	Sumitomo to Nord Conversion Kit (See Page 52)

Units with 060-02266 (after 8/2013) are equipped with a multi-bolt pattern plate. Motor can be replaced without the need of the conversion kit:

<u>Item</u>	<u>Part Number</u>	<u>Qty</u>	<u>Description</u>
2	060-02266	1	Motor Assembly, 110V/60 Hz

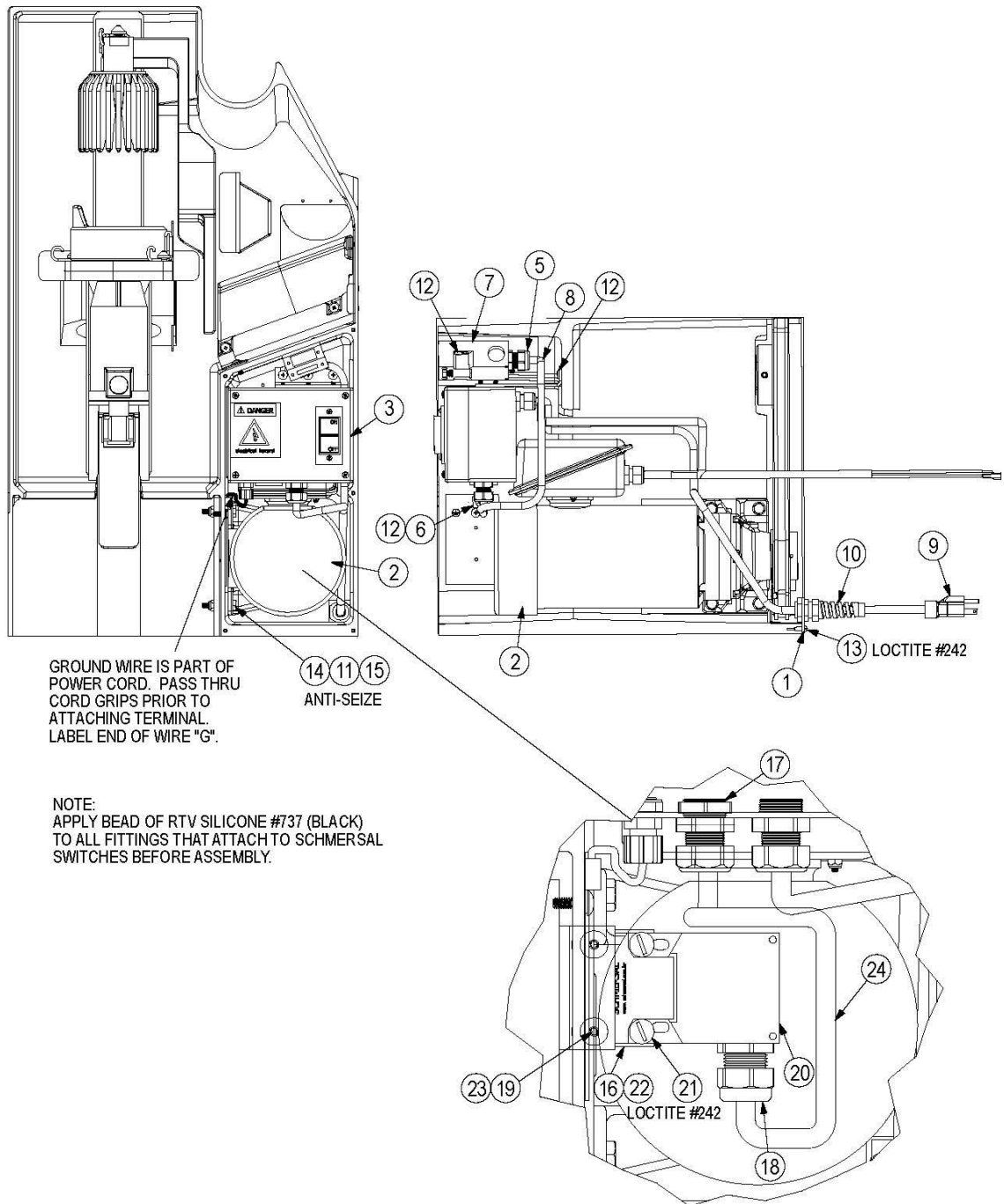

UNITS EQUIPPED WITH WASTE CONTAINER ASSEMBLY

Figure 35. Electrical Parts (110 V)



Sumitomo to Nord Motor Conversion Kit (110 Volt), 060-10157

<u>Item</u>	<u>Part Number</u>	<u>Qty</u>	<u>Description</u>
1	060-10156	1	Adapter, Sumitomo to Nord Motor Conversion Plate
2	060-02266	1	Motor Assembly, CJ, 110V/60Hz, Nord, Mfg Use
3	004-816-072	6	Washer, Plain, 5/16", SS
4	004-806-060	4	Washer, Lock Reg, 5/16", SS
5	004-356-160	4	Screw, Cap, Socket, 5/16-18 X 1-1/4" LG, Fully Threaded, Low Profile, SS
6	004-352-321	4	Screw, Cap Hex, 5/16-18 X 1" LG, SS
7	004-156-063	2	Nut, Hex, S/L, 5/16-18 (Light), SS

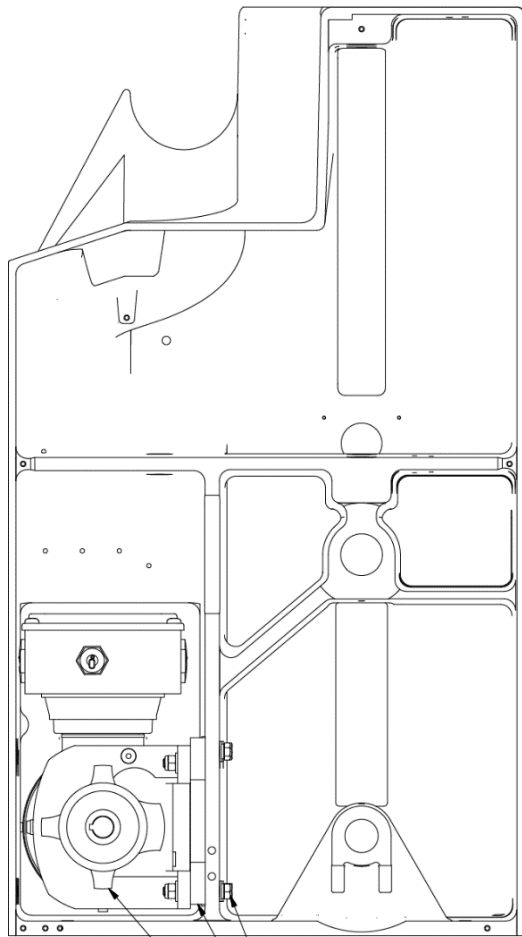

HARDWARE
 BASE PLATE
 MOTOR

STEP 2:
 INSTALL MOTOR AND PLATE ASSEMBLY INTO FRAME
 AND ATTACH AS SHOWN.

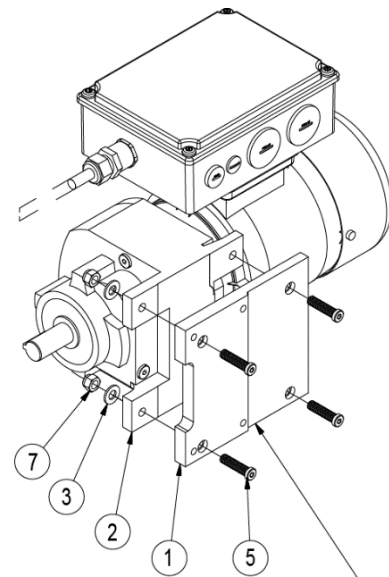

STEP 1:
 INSTALL CONVERSION PLATE TO
 BASE OF MOTOR AS SHOWN.

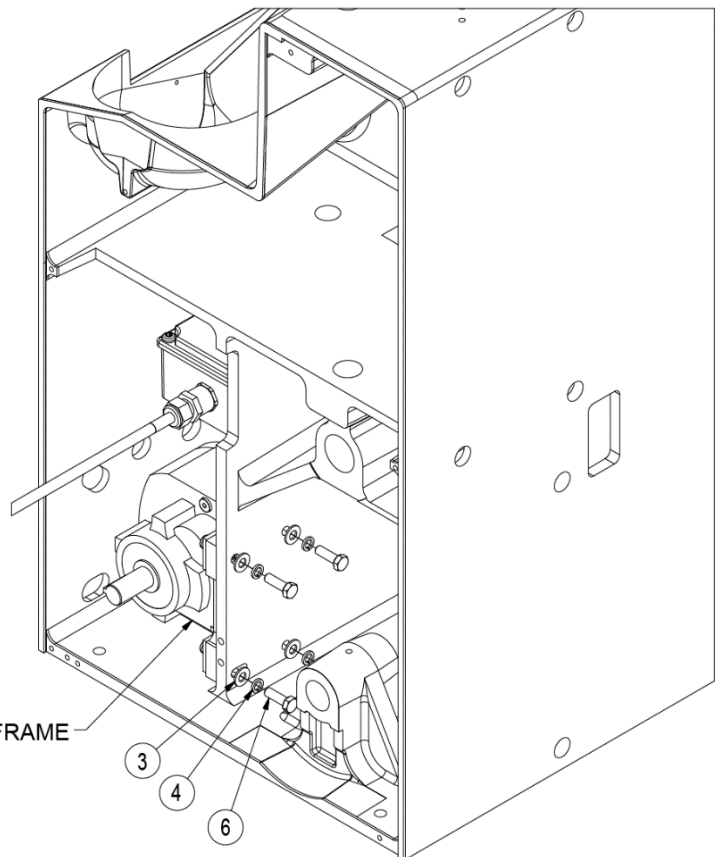

Figure 36. Sumitomo to Nord Motor Conversion Kit



Electrical Parts (220 Volt), 060-02005-01 (50 Hz), 060-02005-02 (60 Hz)

220 Volt Citrus Juicer

<u>Item</u>	<u>Part Number</u>	<u>Qty</u>	<u>Description</u>
1	004-401-026	6	Screw, Mach Truss #10-24 x 5/8" Lg, SS
2	006-220-046	1	Terminal, #10 Ring End, 10-12 Ga, Double Crimp Type
3	006-200-267	1	Switch, Safety, Schmersal
4	060-02041-01	1	Electrical Box Assembly, 220V
5	060-02064-01	1	Motor Assembly, 220V, 50/60 Hz (prior to 8/2013) (Motor is 50/60Hz (same motor); Wire must be changed for voltage over 115V)
5	060-02317	1	Motor Assembly, 220V, 50 Hz (after 8/2013)
5	060-02316	1	Motor Assembly, 220V, 60 Hz (after 8/2013) (for Motor Replacement, see below)
6	007-143-395	2	Connector, Male, M20 x 1-1/2 Thread
7	060-00012	1	Power Cord
8	004-397-077	2	Screw, Mach Rd Slotted, #8-32 x 1/2" Lg, 304SS
9	006-080-073	4 Ft	Cord, 14 Ga, 2 Conductor (2 Pieces x 2 Ft)

Citrus Juicers with Waste Container Assembly

<u>Item</u>	<u>Part Number</u>	<u>Qty</u>	<u>Description</u>
10	060-02085	1	Bracket, Safety Switch
11	007-143-396	1	Fitting, Liquid Tight, Straight Strain Relief
12	007-143-395	1	Connector, Male, M20 x 1-1/2" Thread
13	006-200-268	1	Key, Safety, for 006200267 Schmersal
14	006-200-267	1	Switch, Safety, Schmersal
15	004-401-024	2	Screw Mach Truss #10-24 x 1/2" Lg, SS
16	004-401-022	2	Screw Mach Truss #10-24 x 3/8" Lg, SS
17	004-385-028	2	Screw, Mach FL, Security Type, #8-32 x 3/8" Lg, SS
18	006-080-073	1	Cord, 14 Ga, 2 Conductor x 1-1/2 Ft

Motor Replacement

For units with 060-02064-01 (prior to 8/2013), replacement motor must be same type, due to mounting bolt pattern:

<u>Item</u>	<u>Part Number</u>	<u>Qty</u>	<u>Description</u>
5	060-02064-01	1	Motor Assembly, 220V, 50/60Hz

Units with 060-02317 (after 8/2013) are equipped with a multi-bolt pattern and have the option of using either motor 060-02064-01 or 060-02317:

<u>Item</u>	<u>Part Number</u>	<u>Qty</u>	<u>Description</u>
5	060-02064-01	1	Motor Assembly, 220V, 50/60 Hz
5	060-02317	1	Motor Assembly, 220V, 50 Hz

Units with 060-02316 (after 8/2013) are equipped with a multi-bolt pattern and have the option of using either motor 060-02064-01 or 060-02316:

<u>Item</u>	<u>Part Number</u>	<u>Qty</u>	<u>Description</u>
5	060-02064-01	1	Motor Assembly, 220V, 50/60 Hz
5	060-02316	1	Motor Assembly, 220V, 60 Hz

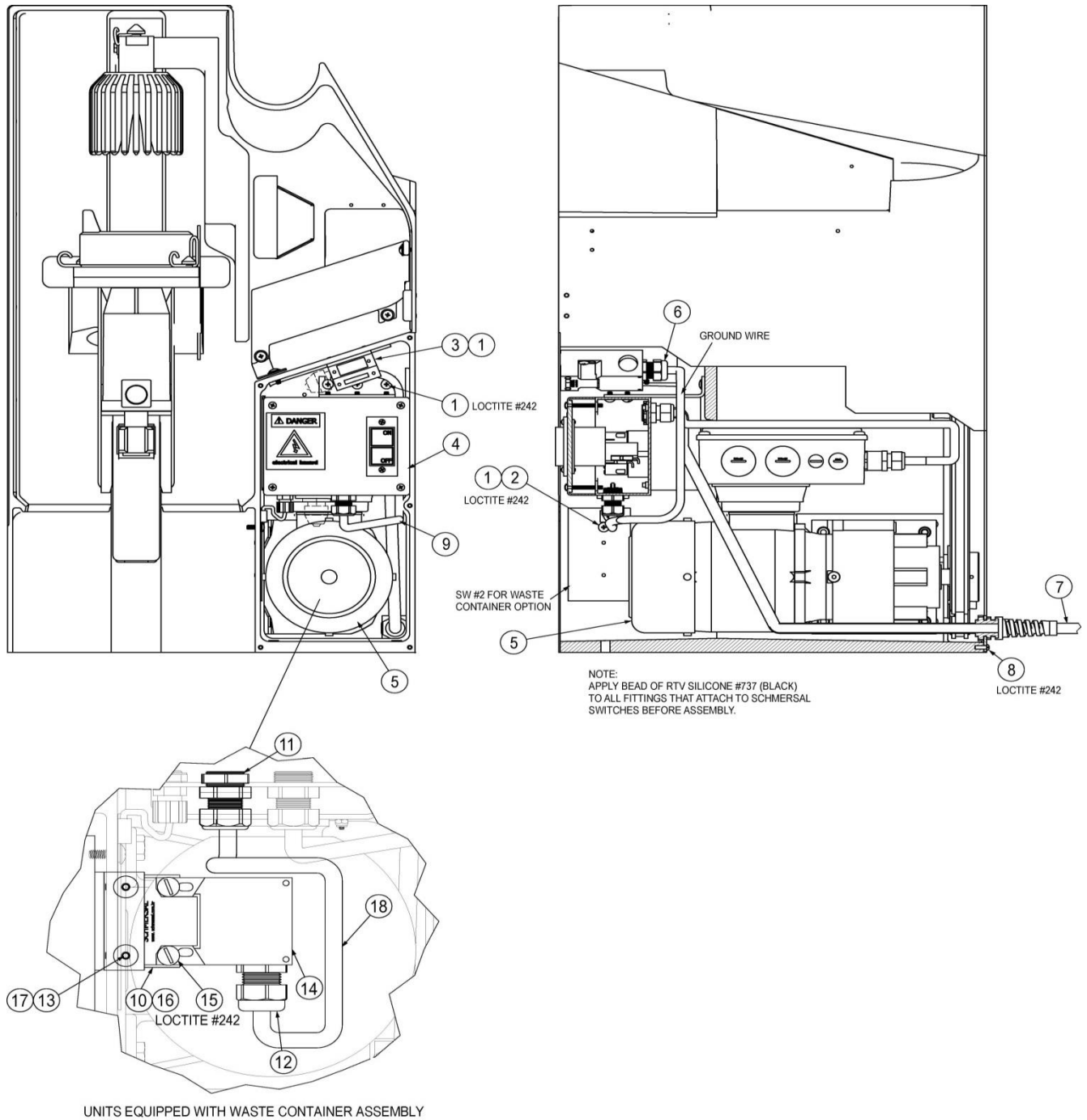

Figure 36. Electrical Parts (220V)



Electrical Box Assembly 060-02041

110 Volt Citrus Juicer

<u>Item</u>	<u>Part Number</u>	<u>Qty</u>	<u>Description</u>
1	060-02039	1	Box, Electrical
2	006-060-078	1	Connector, Cord, 1/4 NPT for 3/16, #056-14-1002
3	007-143-386	2	Connector, 1/2", #S2112
4	006-221-079	1	Terminal, Block
5	006-200-511	1	Switch, On/Off
6	009-235-073	1	Gasket, Weber #AZZ63 Weber
7	004-397-018	2	Screw Mach, Round, #4-40 x 1" Lg, SS
8	004-440-011	2	Screw, Tap, Pan "F" Head 6-32 x 1/2" Lg
9	060-05064	2	Spacer, Terminal Block
10	007-143-388	3	Ring, Thd-Seal, 1/2", #52005740
11	007-143-387	2	Nut, Locking, 1/2", PVC, #LT9LD
12	060-00096-08	1	Wire, 16 Ga, Black, 10" Lg
13	006-221-084	2	Terminal, Fem Insul, Wire 22-18
14	009-455-002	A/R	Marker, Pins, Phoenix #BNB:1-6
15	004-440-010	2	Screw, Tap, "F", #4-40 x 3/8" Lg, SS
16	006-221-082	1	Terminal, Fem Insul, Wire 16-14
17	060-02040	1	Bracket, Electrical Box
18	004-401-022	4	Screw Mach Truss Head, 10-24 x 3/8" Lg, SS
19	006-090-209	1	Seal, Hole, Conduit 1/2, Hoffman AS050
20	060-00096-07	2	Wire, 20 Ga, White, 10" Lg
21	007-143-396	1	Connector, Sol Flex
22	009-450-057	1	Label, Caution, Electrical Hazard

220 Volt Citrus Juicer

<u>Item</u>	<u>Part Number</u>	<u>Qty</u>	<u>Description</u>
3	007-143-386	2	Connector, 1/2", #S2112
5	006-200-266	1	Switch, On/Off, Weber AHWTS070Z3
10	007-143-388	4	Ring, Thd-Seal, 1/2", #52005740
11	007-143-387	2	Nut, Locking, 1/2", PVC, #LT9LD
12	060-00096-08	2	Wire, 16 Ga, Black, 10" Lg
16	006-221-082	2	Terminal, Fem Insul, Wire 16-14
21	007-143-396	2	Connector, Sol Flex

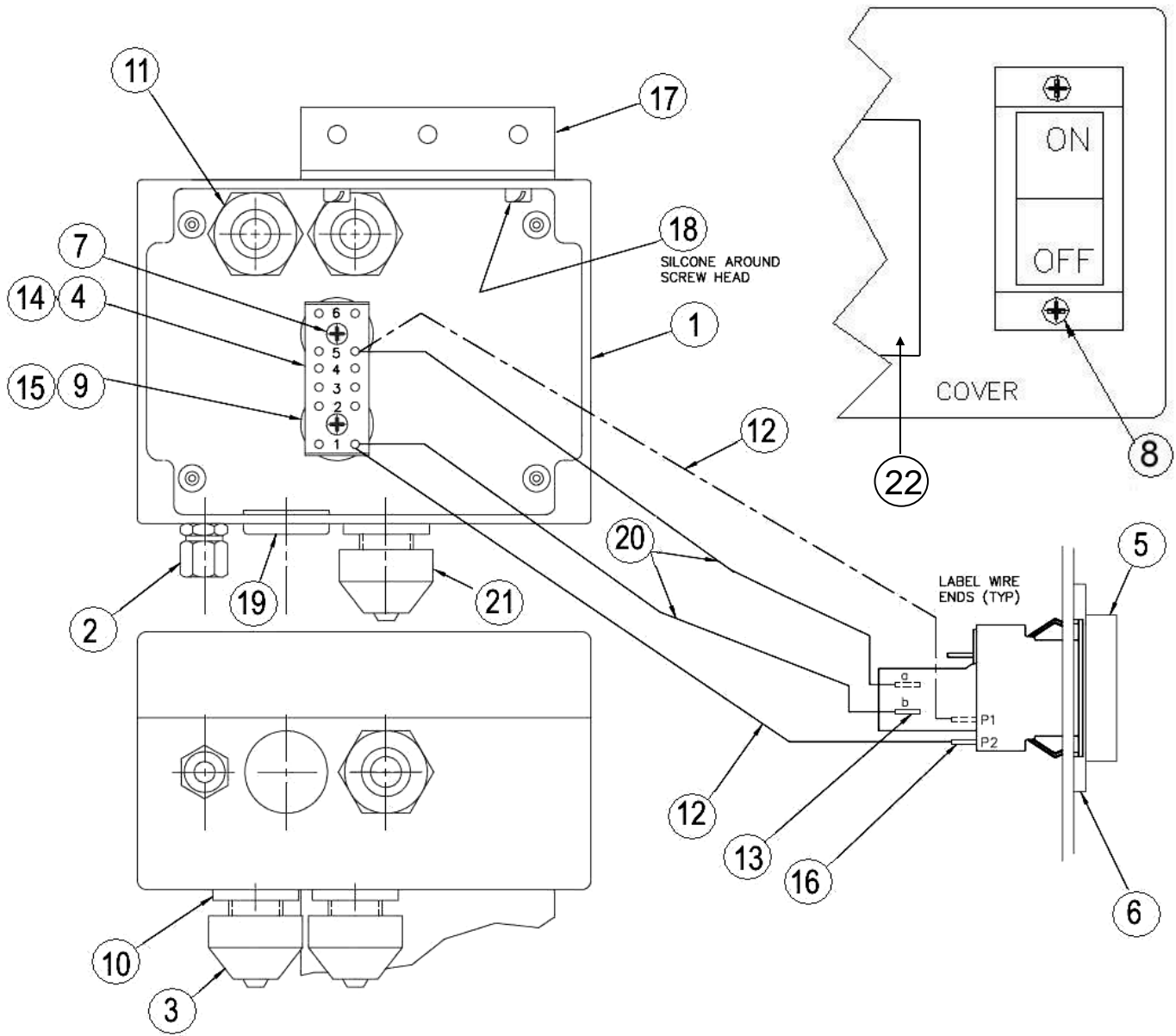

Figure 36. Electrical Box



Cover Parts 060-02003

<u>Item</u>	<u>Part Number</u>	<u>Qty</u>	<u>Description</u>
2	060-02019	1	Fruit Guide
3	060-02152	1	Guard, Splash, Lower, SS
4	060-02032	1	Spring, Cup, Upper
8	060-02150	1	Guard, Splash, Center
9	004-392-193	2	Screw, Machine, Pan Head, #6-32 x 7/8" Lg, SS
10	060-02151	1	Guide, Center
12	060-02279	1	Guard, Splash, Upper, SS
13	060-02045	1	Fruit Guide, Wire Frame
14	060-02240	1	Front Door Assembly
15	060-02165	1	Fruit Lift, Plastic (after 6/2016)
	060-02023	1	Fruit Lift (before 6/16, field service use only after 6/2016)
16	060-02066	1	Cover, Back
17	060-02028	1	Guard, Wire Finger
18	060-02033	1	Cover, Electrical Access
19	060-02018	2	Pin, Lower Cup
20	004-440-011	2	Screw, Tap, Pan "F" Head, #6-32 x 1/2" Lg
21	004-397-129	2	Screw, Mach Rd, 10-24 x 1/4" Lg, SS
22	004-401-024	4	Screw, Mach Truss, #10-24 x 1/2" Lg, SS
23	004-352-260	2	Screw, Cap Hex, 1/4-20 x 2-1/2" Lg, SS
23a	004-352-267	2	Screw, Cap Hex, 1/4-20 x 3", SS
24	004-385-053	2	Screw, Mach FL S/L, 8-32 x 3/8" Lg, SS (Hinge To Frame)
25	060-02067	1	Latch, Door
27	015-03937	1	Patent Plate
28	015-03935	1	Name Plate
29	060-00120	2	Sign, Warning, Covers, Single Head
30	060-00176	2	Label, Warning, Cover, Spanish
31	004-260-017	8	Rivet, Pop, 1/8" x 1/8" Lg, SS
32	060-02069	1	Label, Off/On
33	060-02070	1	Clip, Lower Splash Guard
34	004-401-022	1	Screw, Mach Truss, 10-24 x 3/8" Lg, SS
35	060-02139	11	Screw, Captive Panel, Pan Head, #8-32 x 1/2" Lg, SS
36	004-816-060	2	Washer, Plain, 1/4, Narrow, SS
37	060-02077	1	Gasket, Electrical Access Cover
38	004-385-023	6	Screw, Mach Flat Head, 8-32 x 1/4" Lg, SS
39	004-380-014	1	Screw, Fillester Head, #10-24 x 5/16" Lg, SS
40	060-02128	1	Cover, Straight Side
41	060-02129	1	Cover, Hopper Side
42	003-810-007	20 Ft	Tape, Double Sided, 3/4 Wide x 25 Mils Thick
44	006-090-256	2	Plug, Hole, 1/4
45	060-02087	1	Safety Key
46	060-02059	2	Button, Door
47	004-385-028	2	Screw, Mach Flat, S/L, 8-32 x 3/8" Lg, SS
48	060-00104	1	Decal, Warning, English/Spanish (on side of item 41)

Citrus Juicers with Solid Fruit Guide

<u>Item</u>	<u>Part Number</u>	<u>Qty</u>	<u>Description</u>
49	060-02274	1	Weldment, Upper Fruit Guide
50	060-02192	1	Fruit Guide Mount, Lower
51	060-02191	1	Frame Casting, Machined
52	060-02181	1	Fruit Guide, Plastic, Lower
53	060-02165	1	Fruit Lift, Plastic
54	004-816-052	4	Washer, Plain, #10, SS
55	004-401-026	2	Screw, Mach TRS, Phillips, Pellet, 10-24 X 5/8", SS
56	004-401-022	1	Screw, Mach, TRS, Nylok, Phillips, Pellet, 10-24 X 3/8", SS
57	004-352-152	1	Screw, Cap, Hex, #10-24 x 5/8" LG, SS

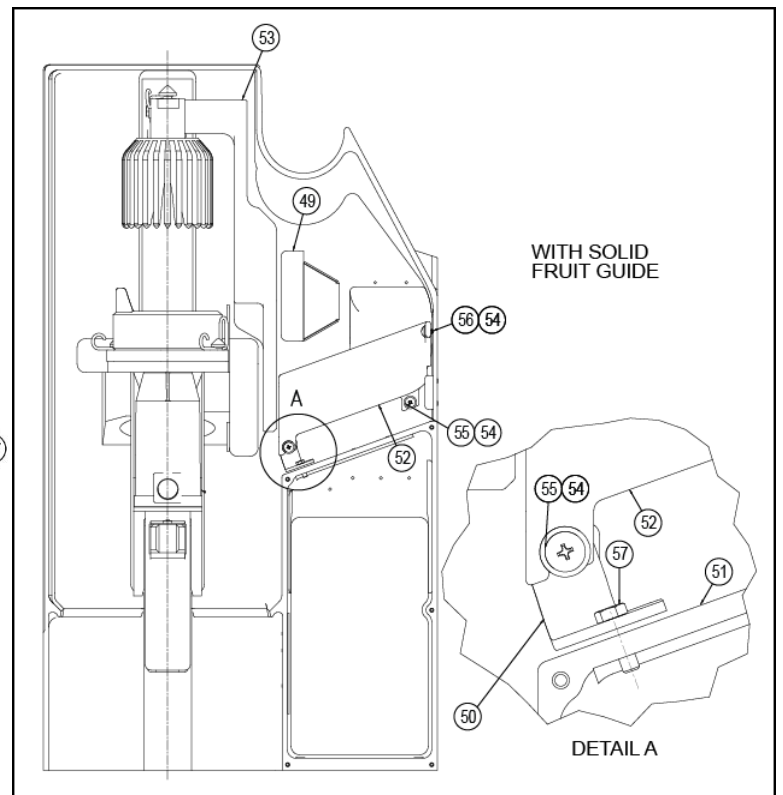
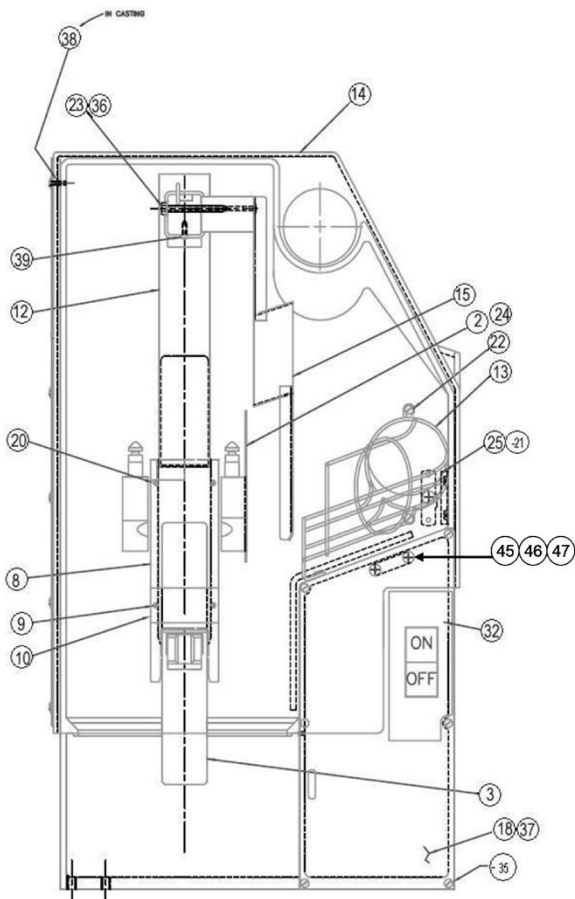
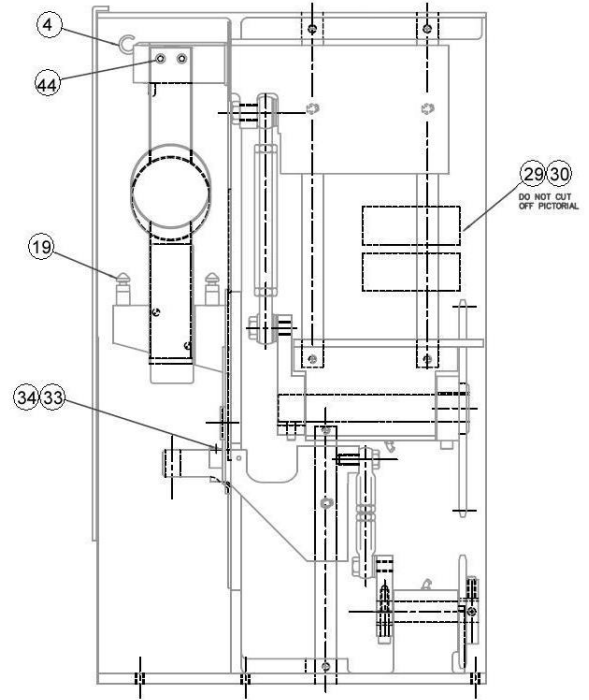
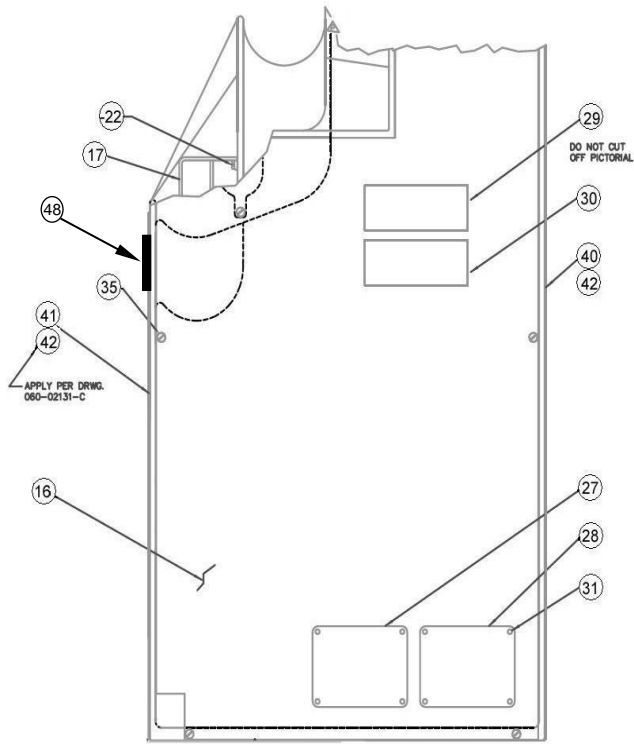

Figure 37. Covers



Hopper Parts – Low Profile [060-02092](#)

<u>Item</u>	<u>Part Number</u>	<u>Qty</u>	<u>Description</u>
1	060-02083	1	Hopper, Basket Only
2	060-02081	1	Disk, Hopper
3	060-02079	1	Hub, Mounting
4	060-02076	1	Hub, Drive Disk
5	060-02082	2	Bumper, Disk
7	004-401-032	4	Screw, Mach Truss Head, 10-24 x 1" Lg, SS
8	005-098-741	1	Bearing, Flange, 5/8B, Dixon #DR6F-1014-8
9	005-250-323	1	Clutch, Overrunning, 5/8 Bore x 5/8 Lg
10	060-02075	1	Disk, Drive
11	060-02073	1	Shaft, Drive
12	004-221-055	1	Pin, Roll, 3/16 x 1-1/2" Lg, SS
13	005-301-050	1	Collar, Nylon, 3/4B
14	004-401-026	5	Screw, Mach Truss Head, #10-24 x 5/8" Lg, SS
15	060-02090	1	Post, Mounting, Angled
16	004-415-017	3	Screw, Shoulder, 1/4 x 1/4 x #10-24, SS
17	060-02110	3	Pulley, Round Belt, 1-3/8 OD
18	004-397-171	2	Screw, Mach Round Head, #10-24 x 1-1/2" Lg, SS
19	060-02091	1	Post, Mounting, Rectangular
20	004-415-019	1	Screw, Shoulder, 5/16 x 1 x 1/4-20"
20	004-461-025	1	Hook, SS (Old Style) (Not Shown)
21	004-401-030	2	Screw, Mach Truss Head, #10-24 x 3/4" Lg, SS
22	009-715-100	1	Spring, Extension, 0.063 Dia Wire x 1-1/2" Lg, SS
23	060-02074	1	Cable Assembly
24	007-661-058	1	Slinger, Shaft Seal, 3/4"
25	060-02098	1	Seal, Shaft
26	004-401-022	4	Screw, Mach Truss Head, #10-24 x 3/8" Lg, SS

Citrus Juicers with Dual Clutch Drive and One-Piece Agitator

<u>Item</u>	<u>Part Number</u>	<u>Qty</u>	<u>Description</u>
27	060-02306	1	Disk, Hopper
28	060-02303	1	Mounting Hub
29	060-02339	1	Shaft, Hopper Disk, Dual Clutch
30	060-02301	1	Pin, Dowel
31	060-02297	1	Hub/Bearing, Drive Disk
32	060-02098	1	Seal, Shaft, Hopper Drive
33	004-405-017	1	Screw, Set, Hex SKT, Cup Point, #10-32 x 1/4 LG, S/L, SS
34	060-02337	1	Hopper Drive Disk Assembly, Dual Clutch
35	060-02342	1	Slinger, Shaft Seal

Note: To convert to a new drive or agitator system, all components listed above are required.

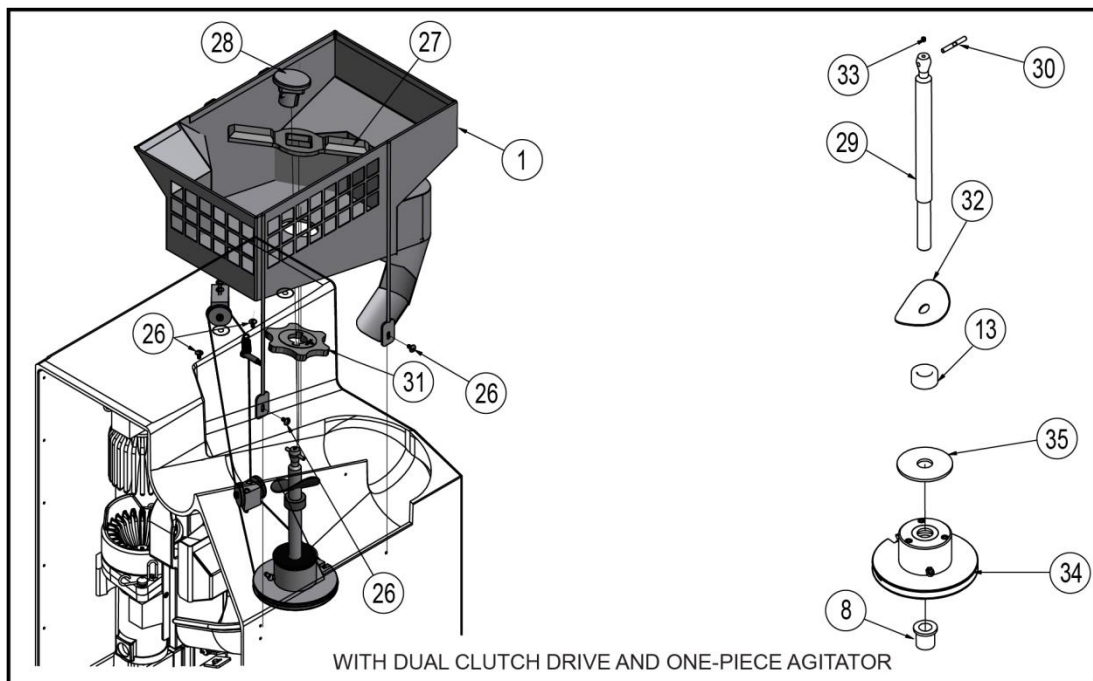
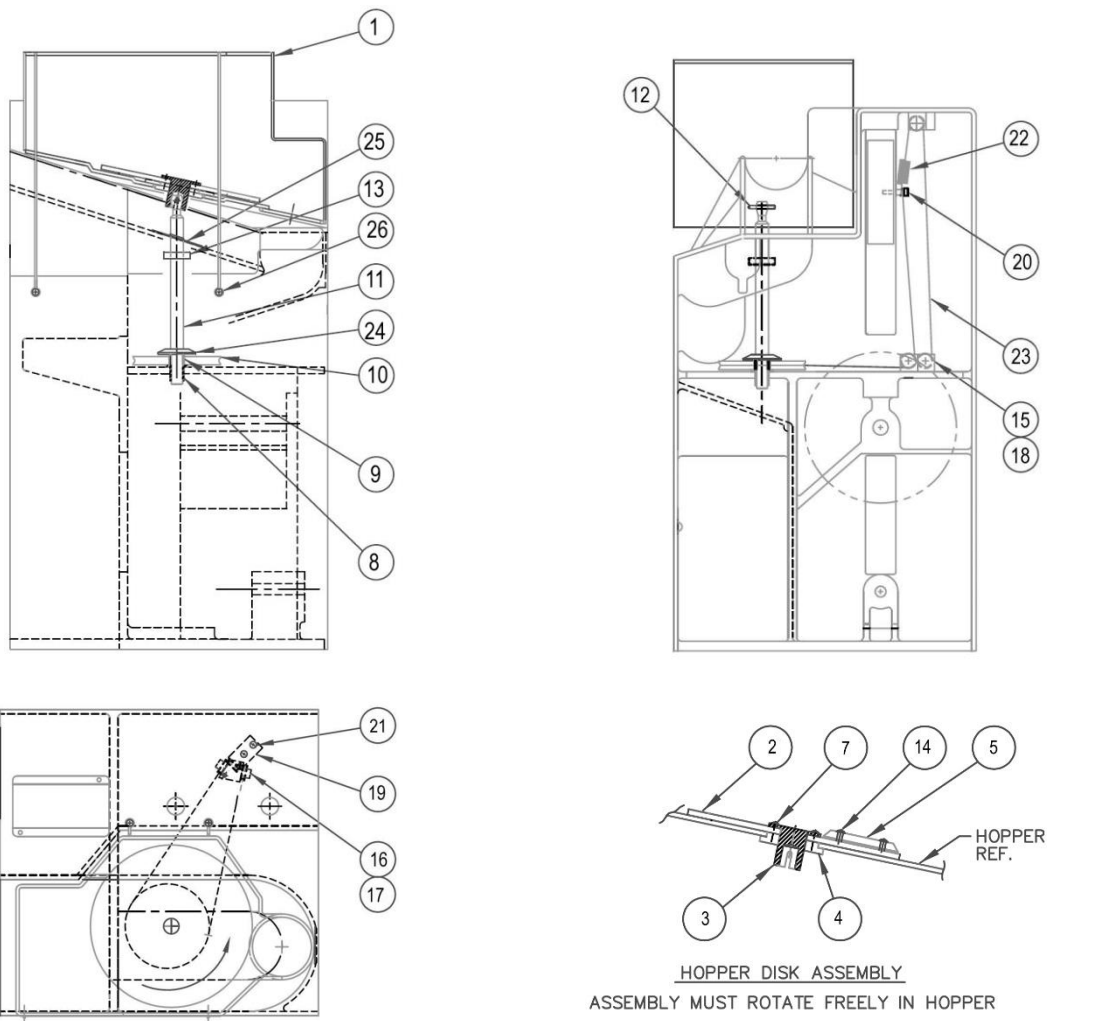

Figure 38. Hopper Parts – Low Profile



Hopper Parts – High Capacity (Round) 060-02198

<u>Item</u>	<u>Part Number</u>	<u>Qty</u>	<u>Description</u>
1	060-02339	1	Shaft, Hopper Disk, Dual Clutch
2	060-02301	1	Pin, Dowel
3	005-301-050	1	Collar, Nylon, 3/4"B
4	005-098-741	1	Bearing, Flange, 5/8"B X 7/8" OD X 1" LG
5	004-405-017	1	Screw, Set, Hex SKT, Cup Point, #10-32 x 1/4" LG, S/L, SS
6	060-02091	1	Post, Mounting, Short
7	060-02090	1	Post, Mounting, Angled
8	060-02110	3	Pulley, Drive, Hopper
9	004-415-017	1	Screw, Shoulder, 1/4" X 1/4" X 10-24, SS
10	004-397-171	4	Screw, Mach RD, #10-24 X 1 1/2", SS
11	004-415-019	1	Screw, Shoulder, 5/16" X 1 X 1/4-20, Alloy Steel, Socket Head
12	009-715-100	1	Spring, Extension, .063 DIA Wire, 1 1/2" OD, LG, SS
13	060-02098	1	Seal, Shaft, Hopper Drive
14	060-02187	1	Weldment, Hopper Extension
15	004-401-022	4	Screw, Mach TRS, HD, SS, # 10-24 X 3/8", SS
16	004-401-030	2	Screw, Mach TRS, #10-24 x 3/4", SS
17	060-02074	1	Cable, Assembly, Hopper
18	060-02314	1	Assembly, Round Hopper
19	060-02337	1	Hopper Drive Disk Assembly, Dual Clutch
20	060-02342	1	Slinger, Shaft Seal
21	060-02340	1	Spacer, Extension, Hopper Drive Shaft

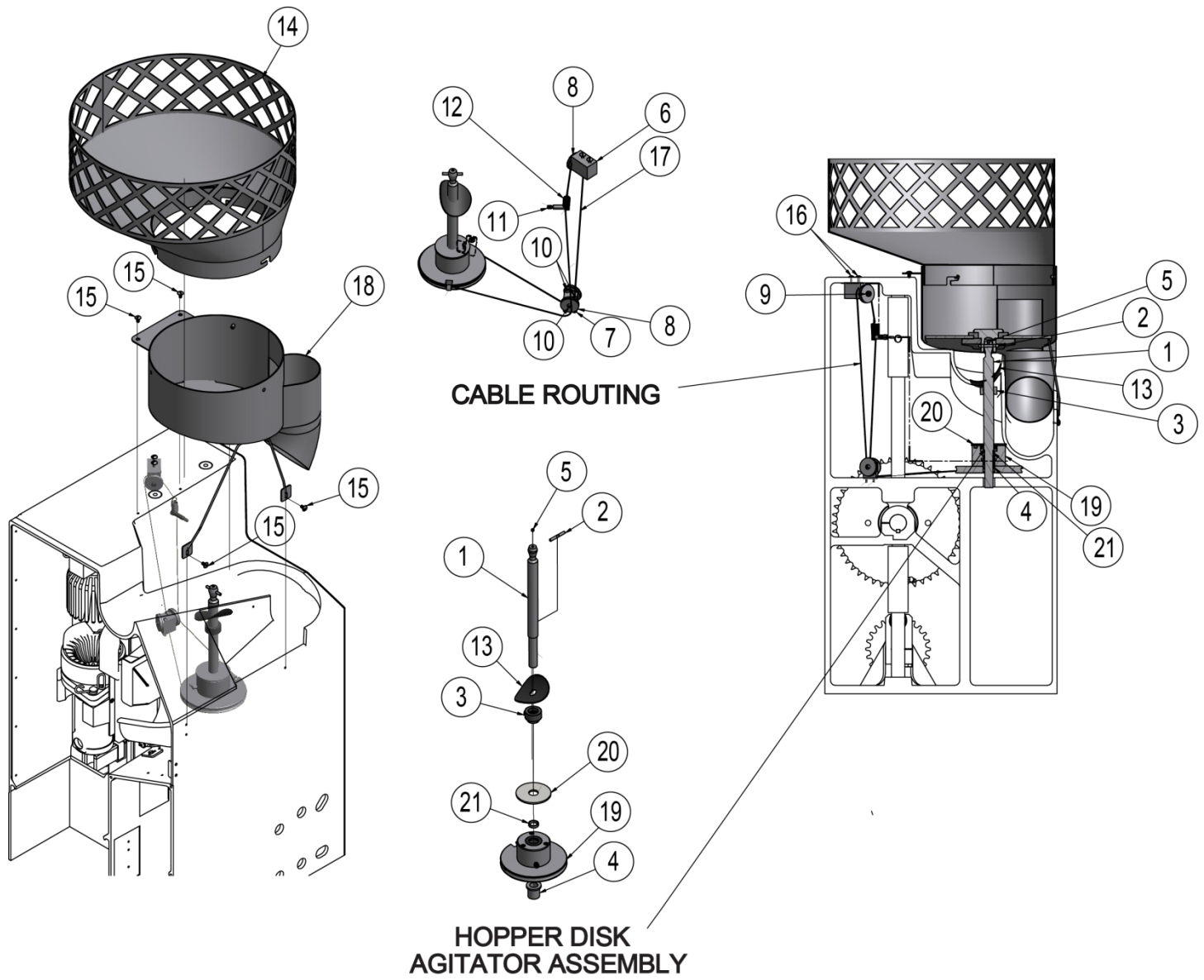

Figure 38. Hopper Parts – High Capacity (Round)



Waste Container Assembly **060-02231/060-02231-01**

<u>Item</u>	<u>Part Number</u>	<u>Qty</u>	<u>Description</u>
1	060-02230	1	Waste Container (6-1/2" Deep)
1	060-02230-01	1	Waste Container (10-1/2" Deep)
2	009-270-011	1	Drawer Pull, Black, Southco #P2-41
3	060-02059	4	Door Button
4	060-02084	1	Bracket, Safety Key
5	004-385-028	4	Screw, Flat Head SS #8-32 x 3/8" Spanner Security Type
6	060-02087	1	Safety Key
	009-020-130	5	Leg, Adjustable, 1-5/8" OD, 1/2-13 Stud, SS (Not Shown)
Non-Adjustable Legs			
	060-02126	5	Non-Adjustable Leg for Counter Top Juicer (Not Shown)
	060-02127	5	Stud, Leg for Counter Top Juicer (Not Shown)
	007-145-210	5	Cap, Plastic, 7/8" ID x 11/16" H, Black Polyethylene (Not Shown)

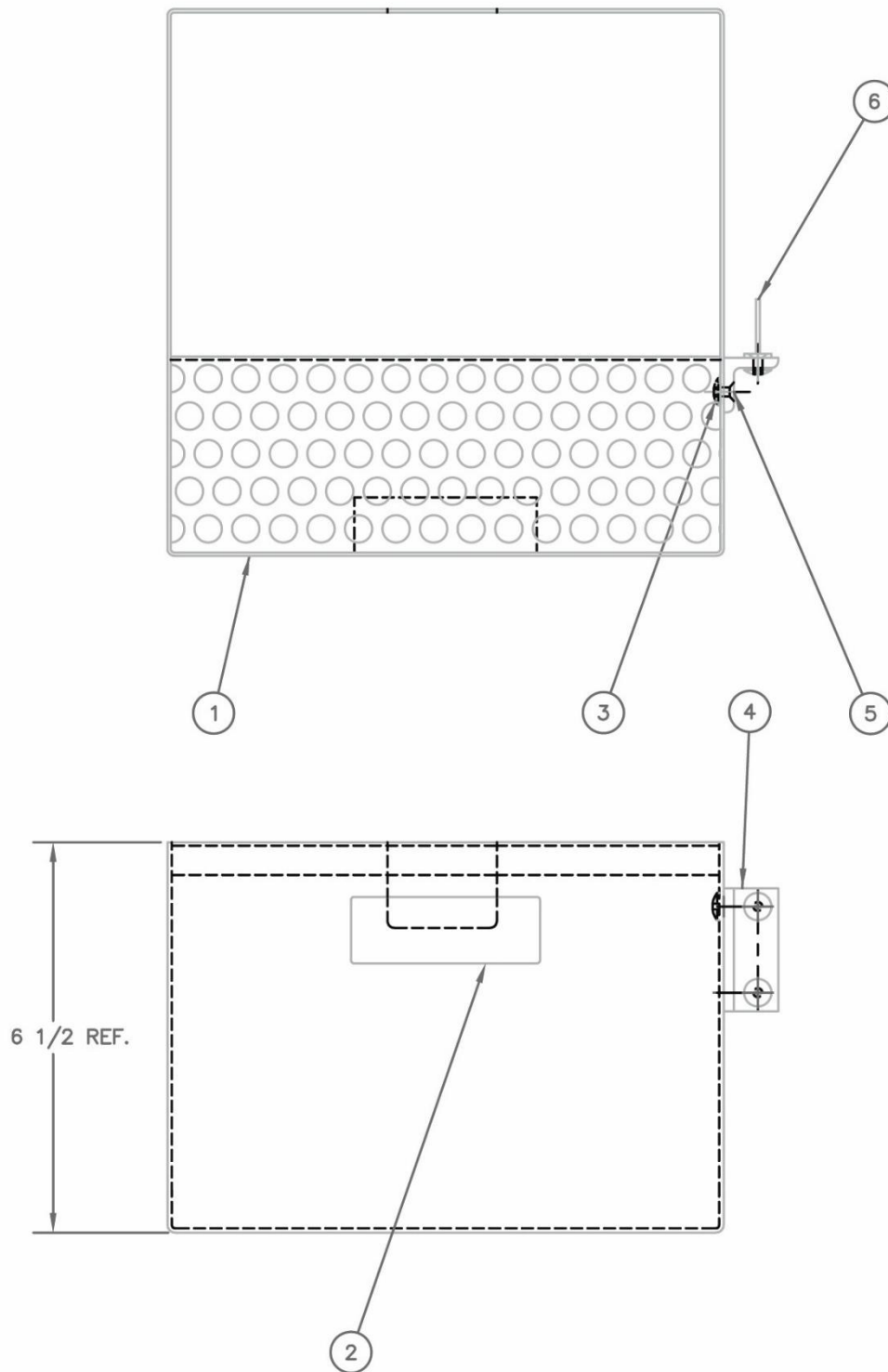

Figure 40. Waste Container Assembly



Miscellaneous Parts

<u>Item</u>	<u>Part Number</u>	<u>Description</u>	
1	060-00084	Rod, Orifice Clean Out	
2	009-080-328	Brush, Metal Wire, 1" Diameter	
3	009-080-327	Brush, Plastic	
4	003-091-001	CorKlean Cleaner, 10 lb.	
5	009-092-019	Decanter, 1 Gallon, Translucent	
6	009-425-020	Key, Tool Head	
7	009-710-031	Sharpening Stone	
8	009-092-018	Red Cutter Cap	
	060-05058-B	Key Ring	(Not Shown)
	009-092-019	Pitcher	(Not Shown)
	003-460-053	Lubricant with Teflon, 3 Oz. Tube	(Not Shown)
	003-015-905	Silicone, White, 3 Oz. Tube	(Not Shown)
	060-00298	Kit, CJ, Bearing Overhaul	(Not Shown)
	060-00296	Kit, CJ, Bearing Overhaul (includes Shafts)	(Not Shown)
	007-145-210	Leg Caps	(Not Shown)
	060-000-077	Tool, Wrench Spanner	(Not Shown)
	060-050-058	Leg Caps	(Not Shown)

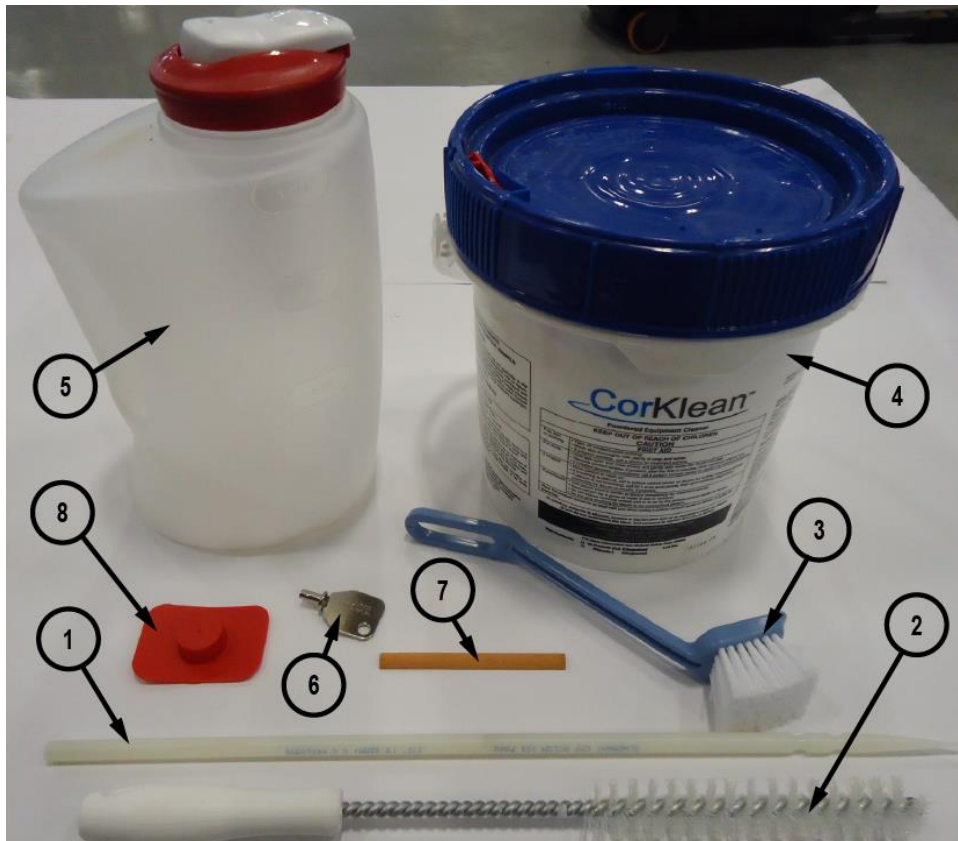

Figure 41. Miscellaneous Parts